



Universal Groomer Drive Kit

Reelmaster® 18-inch, 22-inch, or 27-inch EdgeSeries™ Cutting Units with 5-inch or 7-inch Reel

Model No. 03763—Serial No. 321000000 and Up

Model No. 03768—Serial No. 321000000 and Up

Installation Instructions

Introduction

Important: Before installing this kit, ensure that you have a compatible cutting unit:

03763 is designed for use on Reelmaster DPA Cutting Units with a 5 inch reel.

03768 is designed for use on Reelmaster DPA Cutting Units with a 7 inch reel.

Refer to the following table for further detail:

Universal Groomer Drive Kit	Compatible Cutting Units	Incompatible Cutting Units
03763	All aluminum side plate cutting units, Model Numbers: 03911/2, 03485/6, 03621/3/4, and 03487/8/9	Painted red side plate DPA cutting units, Model Numbers: 03661, 03694/5
03768	All aluminum side plate cutting units, Model Numbers: 03636/7/8/9, 03641/43, and 03721/2	Painted red side plate DPA cutting units, Model Numbers: 03681/2, 03696/7/8/9, 03693, and 03863/4

Read this information carefully to learn how to operate and maintain your product properly and to avoid injury and product damage. You are responsible for operating the product properly and safely.

Visit www.Toro.com for product and accessory information, help finding a dealer, or to register your product.

Whenever you need service, genuine Toro parts, or additional information, contact an Authorized Service Dealer or Toro Customer Service and have the model and serial numbers of your product ready. [Figure 1](#) identifies the location of the model and serial numbers on the product. Write the numbers in the space provided.

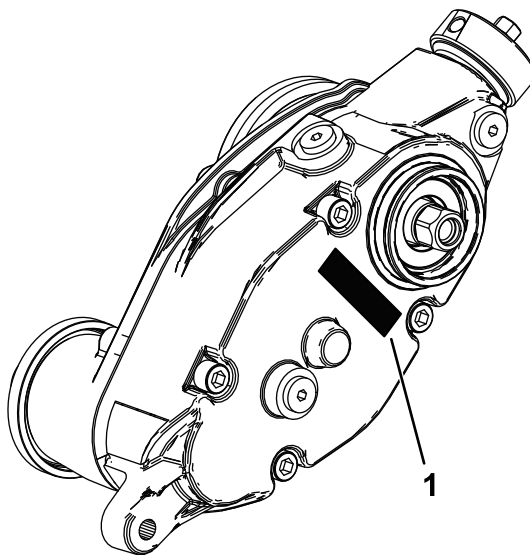

Figure 1

g346921

1. Model and serial number location

Model No. _____
Serial No. _____



Loose Parts

Use the chart below to verify that all parts have been shipped.

Procedure	Description	Qty.	Use
1	No parts required	–	Prepare the machine.
2	Torque wrench (Not included)	–	Gather the tools required for setup.
3	No parts required	–	Determine where on the cutting unit to install the groomer.
4	Extended splined insert (right-hand threads)	3	Prepare the cutting unit.
	Extended splined insert (left-hand threads)	2	
	Flange locknut (3/8 inch)—Model 03768 only	10	
5	Weight bracket	5	Install the weight bracket and groomer drive box.
	Hex-socket, button-head bolt (3/8 x 3/4 inch)	10	
	Groomer drive box (left drive)	3	
	Groomer drive box (right drive)	2	
6	Hex-socket bolt	10	Install the idler assembly.
	Pivot hub	5	
	O-ring	5	
	Idler assembly (left)	2	
	Idler assembly (right)	3	
	Flange locknut (3/8 inch)—Model 03763 only	10	
7	Jam locknut (3/8 inch)—Model 03768 only	10	Install the HOC bracket assemblies and the front roller.
	Left HOC bracket assembly	5	
	Right HOC bracket assembly	5	
	Shoulder bolt	10	
	Hardened washer	5	
8	Flange locknut (3/8 with 5/8 hex)	10	Install the groomer drive cap (For universal groomer assemblies with no rear roller brush kit installed only).
	Cap	5	
9	Bolt (1/4 x 1-1/2 inches)	20	Install the groomer assembly and optional broomer kit.
	Jam nut	20	
	Shaft clamp	20	
	Grooming reel (order separately)	5	
10	Washer (Part No. 3256-24, not included)	–	Adjust the groomer spring force.
11	Hydraulic fitting—45° (Part No. 340-101; sold separately)	1	Install the angled fitting (for Reelmaster 3550 and 3555 machines, #1 front, center cutting location and kit Model 133-0150).

1

Preparing the Machine

No Parts Required

Procedure

1. Park the machine on a level surface.
2. Engage the parking brake.
3. Shut off the engine and remove the key; refer to your *Operator's Manual*.
4. If the cutting unit is installed, remove the cutting unit from the traction unit; refer to the *Operator's Manual* for the traction unit.

2

Gathering the Tools Required for Setup

Parts needed for this procedure:

-	Torque wrench (Not included)
---	------------------------------

Note: Ensure that the torque wrenches are capable of torquing both clockwise and counterclockwise.

- Torque wrench—5.2 to 6.8 N·m (46 to 60 in-lb)
- Torque wrench—16 to 22 N·m (12 to 16 in-lb)
- Torque wrench—20 to 26 N·m (15 to 19 in-lb)
- Torque wrench—115 to 129 N·m (85 to 95 ft-lb)
- Torque wrench—135 to 150 N·m (100 to 110 ft-lb)
- Reel driveshaft tool, Part No. TOR4112 (used only on 5-inch reels)
- Reel driveshaft tool, Part No. TOR4074 (used only on 7-inch reels)
- Long-handled pry bar (3/8 x 12 inches)

Service Tools

Oil syringe (included), Part No. 137-0872; refer to [Changing the Gearbox Lubricant \(page 17\)](#).

Drive shaft tool (optional), Part No. 137-0920; refer to your traction unit *Service Manual* or contact your authorized Toro distributor.

3

Determining the Setup

No Parts Required

Procedure

Use the following diagram to determine the position of the groomer kit and reel motors.

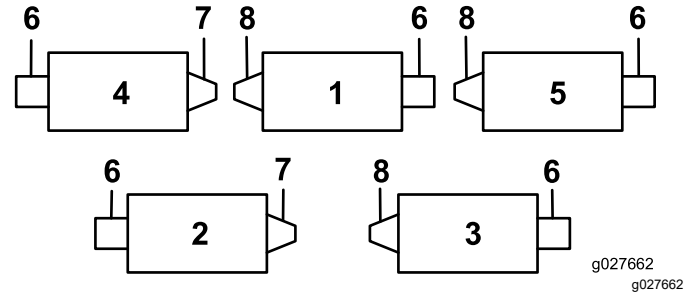

Figure 2

- | | |
|-------------------|----------------------|
| 1. Cutting unit 1 | 5. Cutting unit 5 |
| 2. Cutting unit 2 | 6. Reel motor |
| 3. Cutting unit 3 | 7. Right groomer kit |
| 4. Cutting unit 4 | 8. Left groomer kit |

Note: If you are installing a groomer kit and a rear roller-brush kit on the cutting unit, install the groomer kit first.

4

Preparing the Cutting Unit

Parts needed for this procedure:

3	Extended splined insert (right-hand threads)
2	Extended splined insert (left-hand threads)
10	Flange locknut (3/8 inch)—Model 03768 only

Procedure

Note: You may discard all removed parts unless otherwise stated.

1. Remove all cutting units from the traction unit; refer to your *Operator's Manual*.
2. Restrain the reel to remove the existing splined insert; refer to [Restraining the Reel for Removing Threaded Inserts](#) (page 19).
3. Remove the existing splined insert from each end of the reel shaft using the reel driveshaft tool (Part No. TOR4112 for the 5-inch reel and Part No. TOR4074 for the 7-inch reel). Refer to [Figure 3](#).

Important: The splined insert on the left side of the cutting unit has left-hand threads. The splined insert on the right side of the cutting unit has right-hand threads.

Important: Clean the threads in the end of the reel shaft of any debris or grease before installing the kit splined insert and groomer box.

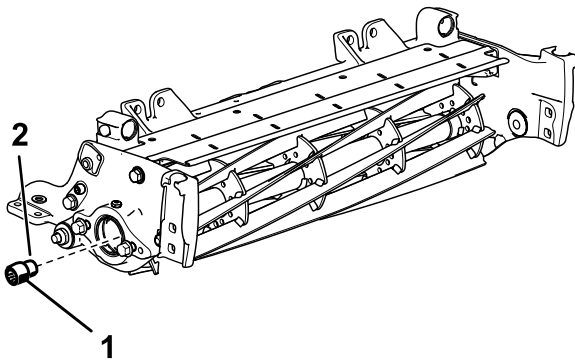

Figure 3

Right side of cutting unit shown

1. Extended splined insert (Torque to 115 to 128 N·m (85 to 95 ft-lb))
2. Apply medium-strength removable locking compound to the threads.

4. Restrain the reel to install the new insert; [Restraining the Reel for Installing Threaded Inserts](#) (page 20).
5. Apply medium-strength thread-locking compound (such as Blue Loctite® 243) to the threads of the new longer splined insert, and secure it to the reel shaft. Torque the insert to 115 to 128 N·m (85 to 95 ft-lb).

Important: Allow the thread-locking compound to cure for 15 minutes before continuing the procedure.

6. Remove the carriage bolts and locknuts securing the height-of-cut (HOC) brackets to the cutting-unit side plates ([Figure 4](#)).

Note: Save the carriage bolts to install the new HOC brackets.

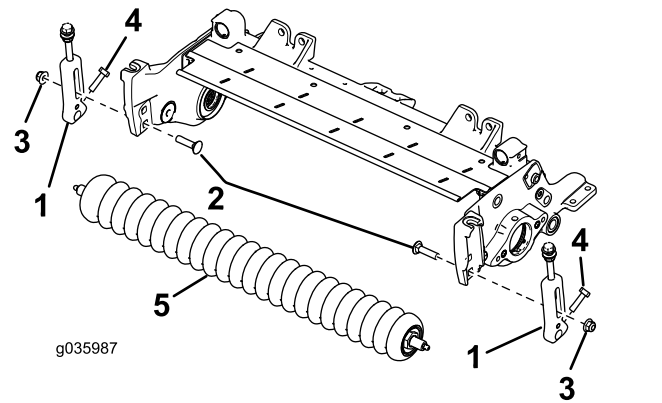

Figure 4

1. Height-of-cut bracket
2. Carriage bolt
3. Locknut
4. Screw
5. Front roller

7. Loosen the screws securing the height-of-cut brackets to the front-roller shaft ([Figure 4](#)).
8. Remove the existing height-of-cut brackets and the front roller from the cutting-unit side plates ([Figure 4](#)).

Note: Save the front roller for later installation.

9. For 7-inch cutting units or if a support rod is installed, remove the support rod and flip the bolts around as follows:
 - A. Remove the 2 flange-head bolts securing the support rod, and remove the support rod ([Figure 5](#)).

5

Installing the Weight Bracket and the Groomer Drive Box

Parts needed for this procedure:

5	Weight bracket
10	Hex-socket, button-head bolt (3/8 x 3/4 inch)
3	Groomer drive box (left drive)
2	Groomer drive box (right drive)

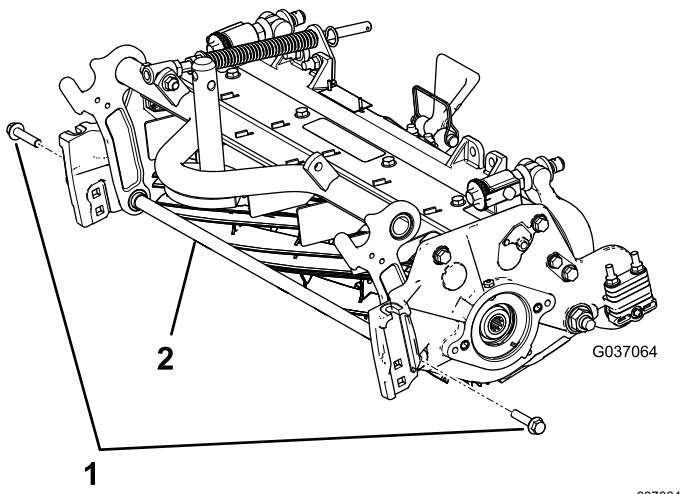

Figure 5

1. Flange-head bolts
2. Support rod

- B. Install the 2 existing flange-head bolts from the inside of the cutting unit, and secure them with the 3/8-inch flange locknuts (Figure 6).

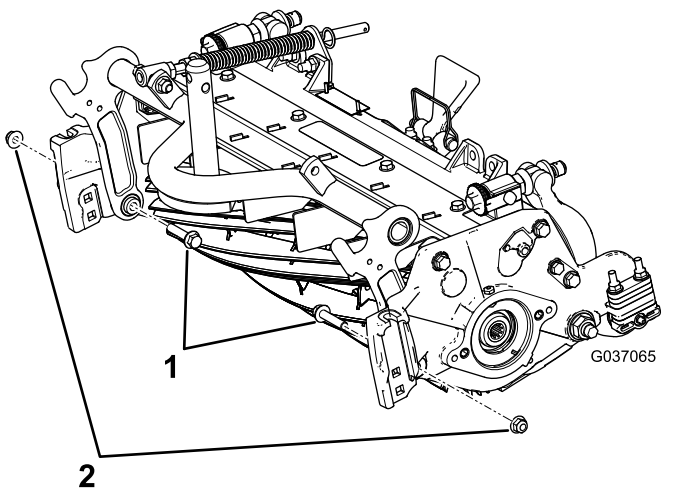

Figure 6

1. Flange-head bolts
2. Flange locknuts (3/8 inch)

Procedure

1. Identify the left-drive groomer drive boxes and the right-drive groomer drive boxes; refer to Figure 7.

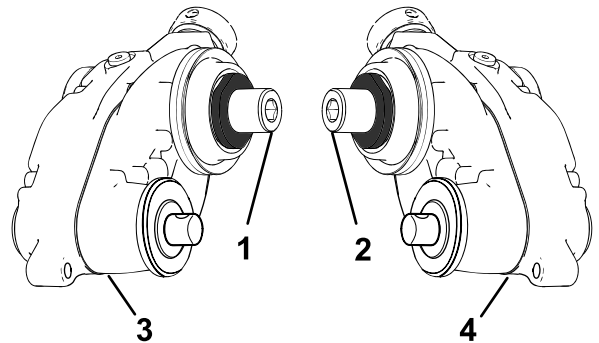

Figure 7

1. Right (yellow) adapter
2. Left (green) adapter
3. Groomer drive box—right drive
4. Groomer drive box—left drive

2. Secure the weight bracket to the reel using 2 hex-socket, button-head bolts (3/8 x 3/4 inch) as shown in Figure 8.

Note: Attach the weight bracket to the side of the reel where you intend to mount the groomer drive box.

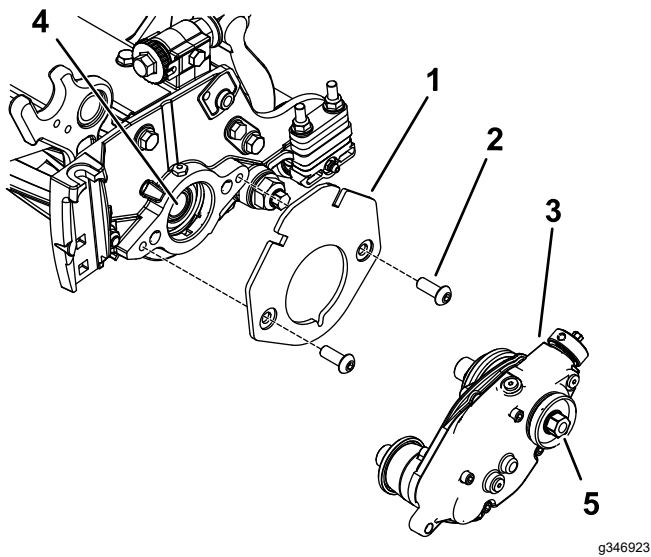

Figure 8

g346923

1. Weight bracket
2. Hex-socket, button-head bolt—3/8 x 3/4 inch (2)
3. Groomer drive box (left drive shown)
4. Thread-locking compound
5. Hex-head (Torque to 135 to 150 N·m (100 to 110 ft-lb))

3. Apply medium-strength thread-locking compound (such as Blue Loctite® 243) to the threads of the internal reel shaft (Figure 8).
 4. Attach the groomer drive box to the reel shaft (Figure 8) using the hex-head on the groomer drive box.
- Important:** The reel threads on the left side of the cutting unit are left-handed, and the reel threads on the right side of the cutting unit are right-handed.
5. Restrain the cutting reel; refer to [Restraining the Reel for Installing Threaded Inserts](#) (page 20).
 6. While the reel is restrained, torque the hex-head of the drive-box shaft to 135 to 150 N·m (100 to 110 ft-lb); refer to [Figure 12](#).

Important: Torque the hex head of the drive-box shaft to 135 to 150 N·m (100 to 110 ft-lb).

Important: Use a 6-point socket with heavy wall.

Important: Do not use an impact wrench for this step.

Important: Allow the thread-locking compound to cure for 15 minutes before continuing the procedure.

6

Installing the Idler Assembly

Parts needed for this procedure:

10	Hex-socket bolt
5	Pivot hub
5	O-ring
2	Idler assembly (left)
3	Idler assembly (right)
10	Flange locknut (3/8 inch)—Model 03763 only
10	Jam locknut (3/8 inch)—Model 03768 only

Procedure

1. Position the idler assembly on the opposite side of the reel from the groomer drive box.
2. Install the O-ring onto the pivot-hub assembly.
3. Apply anti-seize compound on the outside diameter of the pivot-hub assembly (Figure 9).

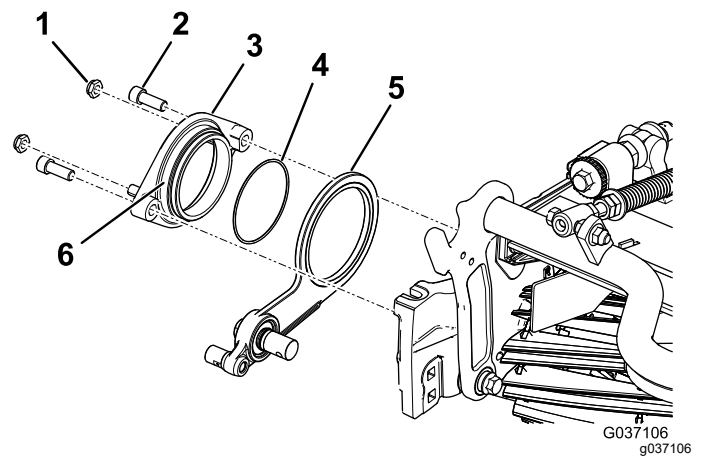

Figure 9

1. Locknut—3/8 inch (2)
2. Hex-socket bolt (2, apply grease to threads)
3. Pivot hub
4. O-ring
5. Idler assembly (right side shown)
6. Apply anti-seize compound on the outside diameter of the hub.

4. Apply grease to the threads of 2 hex-socket bolts, then secure the pivot hub over the idler assembly to the side plate (Figure 9).
5. Loosely install the 2 locknuts on the pivot hub (Figure 9).

7

Installing the HOC Bracket Assemblies and the Front Roller

Parts needed for this procedure:

5	Left HOC bracket assembly
5	Right HOC bracket assembly
10	Shoulder bolt
5	Hardened washer
10	Flange locknut (3/8 with 5/8 hex)

Procedure

- Loosely install the left and right HOC bracket assemblies and the front roller assembly to the cutting-unit side plates using the previously removed carriage bolts (Figure 10).

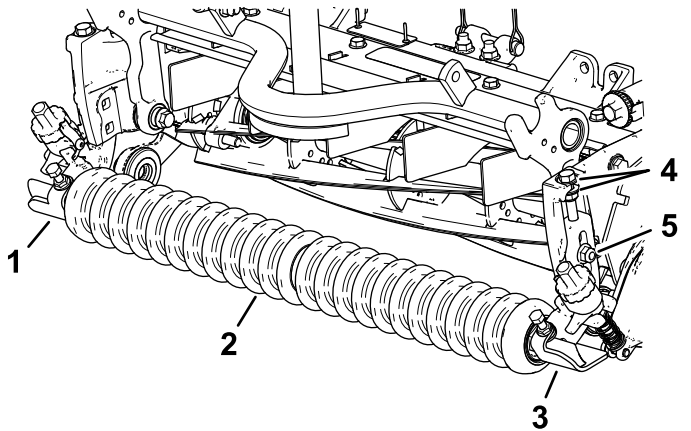

Figure 10

- | | |
|-------------------------------|---|
| 1. Right HOC bracket assembly | 4. Washers |
| 2. Front roller assembly | 5. Carriage bolt and flange locknut (3/8 with 5/8 inch hex) |
| 3. Left HOC bracket assembly | |

- Apply medium-strength cylindrical bonding retaining compound (such as Blue Loctite 242®) to the shoulder bolts prior to installing the adjuster arms to the groomer drive box and the idler assembly.
- On the groomer box side, position the adjuster-arm rod of the HOC bracket on the inside of the groomer drive box and secure it with a shoulder bolt and a hardened washer as shown in Figure 11; torque the shoulder bolt to 16 to 22 N·m (12 to 16 ft-lb).

Note: The shoulder bolt must be installed from the inside of the machine to the outside of the machine.

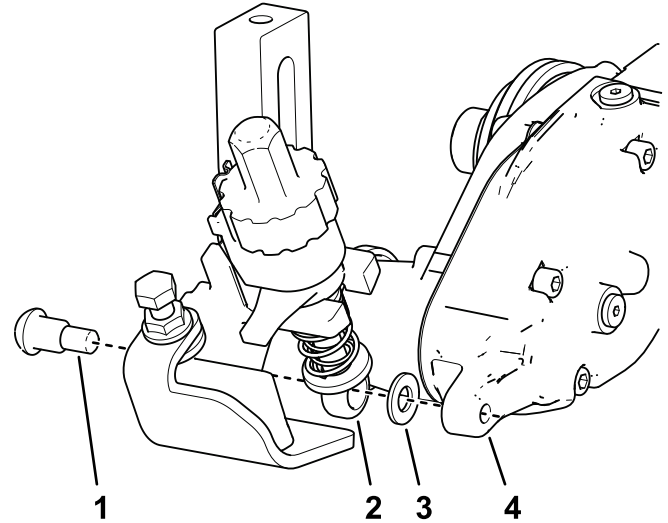

Figure 11

- | | |
|---------------------|----------------------|
| 1. Shoulder bolt | 3. Hardened washer |
| 2. Adjuster-arm rod | 4. Groomer drive box |

- On the idler assembly side, align the adjuster-arm rod of the HOC bracket with the adjuster collar on the idler assembly and secure it with a shoulder bolt as shown in [Figure 12](#); torque the shoulder bolt to 20 to 26 N·m (15 to 19 ft-lb).

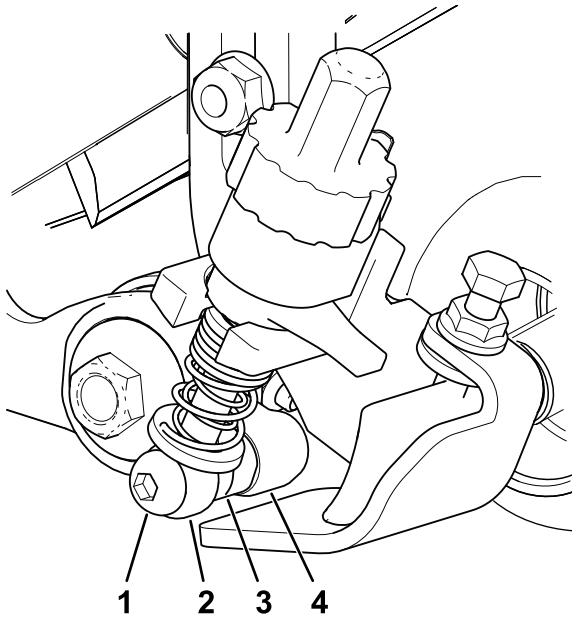

Figure 12

- Shoulder bolt
- Adjuster-arm rod
- Adjuster collar
- Idler assembly

- Tighten the carriage bolts and locknuts securing the HOC bracket assemblies to the side plates ([Figure 13](#)).

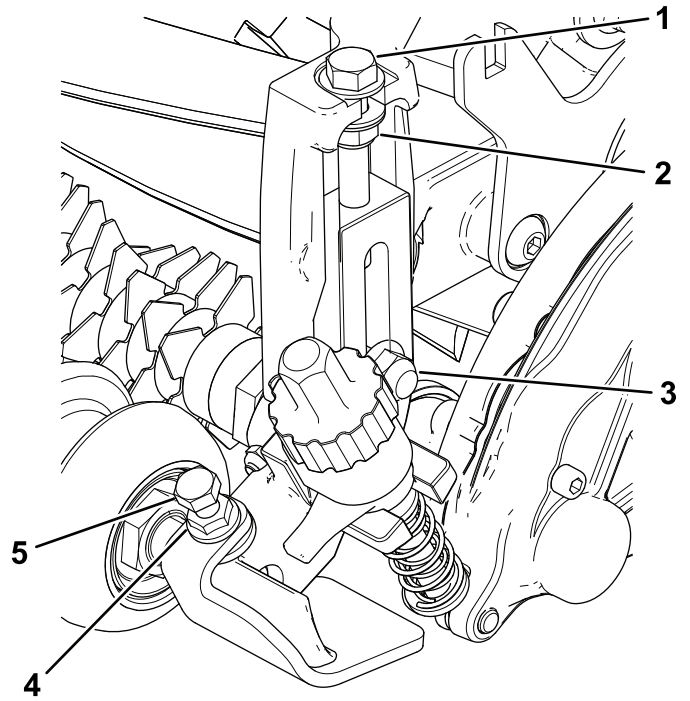

Figure 13

- Adjusting bolt
- Locknut
- Carriage bolt and flange locknut (3/8 with 5/8 inch hex)
- Flange nut
- Capscrew

- Tighten the locknut on the HOC adjuster bolt, then back off the locknut 1/2 turn ([Figure 13](#)).
- Center the front roller between the HOC bracket assemblies and lock it in place with the cap screws and flange nuts ([Figure 13](#)).

8

Installing the Groomer Drive Cap

Parts needed for this procedure:

5	Cap
---	-----

Procedure

Only for Universal Groomer assemblies with no rear roller brush kit installed:

- Apply medium-strength cylindrical bonding retaining compound (such as Green Loctite 609®) around the snap ring groove and the outer diameter surface ([Figure 14](#)).

2. Install the cap as shown in [Figure 14](#).

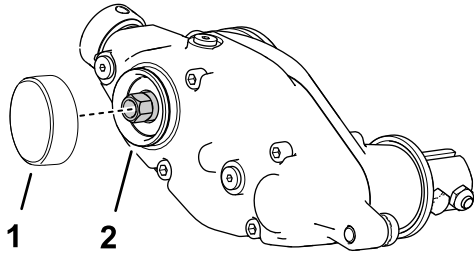

Figure 14

g346927

1. Cap
2. Apply Green Loctite 609®

3. If you are installing the groomer at the left side of the machine, perform the following ([Figure 15](#)):
 - A. Remove the hex-socket screw that secures the clutch knob to the actuator shaft.
 - B. Remove the clutch-knob assembly and flip it over ([Figure 15](#)).
 - C. Assemble the clutch knob to the actuator shaft with the hex-socket screw.

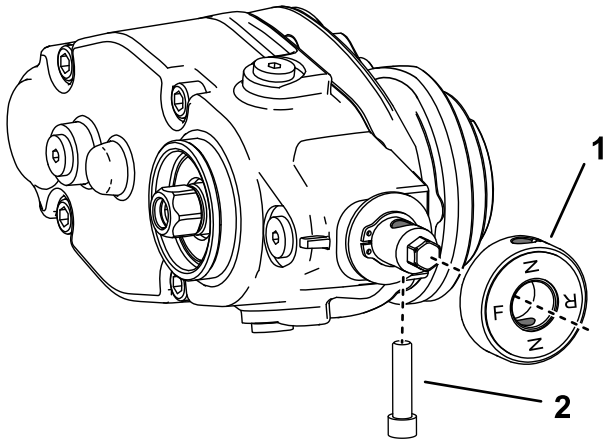

Figure 15

g298196

1. Hex-socket bolt
2. Clutch-knob assembly

9

Installing the Groomer Assembly and Optional Broomer Kit

Groomer and Broomer Kits Come Separately

Parts needed for this procedure:

20	Bolt (1/4 x 1-1/2 inches)
20	Jam nut
20	Shaft clamp
5	Grooming reel (order separately)

Installing the Groomer Kit

Ordered Separately

Model Number	Groomer Kit
03771	18 inch Groomer Blade Cartridge Kit
03772	22 inch Groomer Blade Cartridge Kit
03778	27-inch Groomer Blade Cartridge Kit
03766	18 inch QC Grooming Brush Kit
03767	22 inch QC Grooming Brush Kit

1. Obtain a groomer blade cartridge kit or a brush kit appropriate for your needs and cutting unit; refer to the table above.
2. Line up the groomer assembly with the drive-stub shafts of the groomer drive box and idler assembly ([Figure 16](#)).

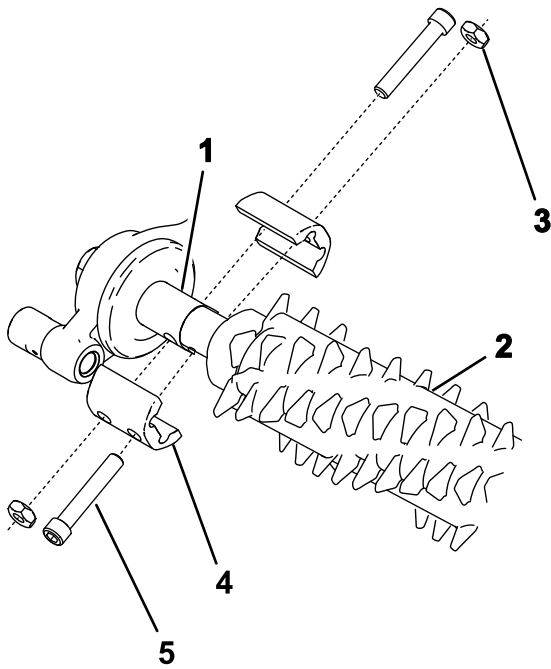
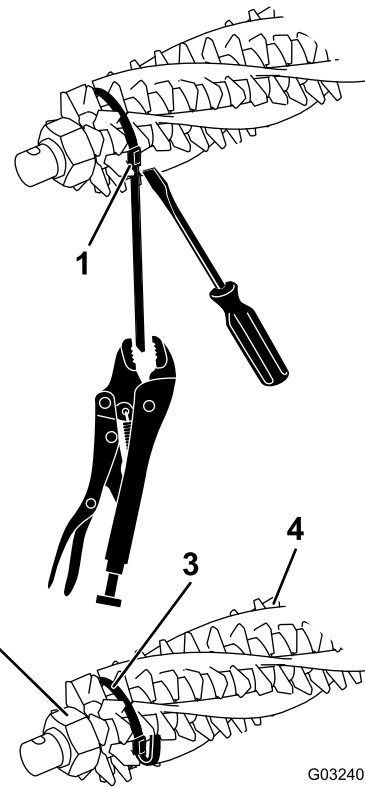

Figure 16

g240752

- | | |
|---------------------|---|
| 1. Drive-stub shaft | 4. Shaft clamp (4) |
| 2. Groomer assembly | 5. Bolt (4) Torque to 5 to 7 N·m (46 to 60 in-lb) |
| 3. Jam nut (4) | |



G032403

g032403

Figure 17

- | | |
|------------------|----------|
| 1. Strap buckle | 3. Strap |
| 2. Retaining nut | 4. Brush |

- Secure the groomer to the machine as shown in [Figure 16](#) and snug the bolts.
- To prevent binding, set the height of cut and height of groom, then loosen the bolts.

Note: To set the height of cut refer to your cutting unit *Operator's Manual*; refer to [Adjusting the Groomer Height \(page 14\)](#) for adjusting the height of groom.

- Torque the bolts to 5 to 7 N·m (46 to 60 in-lb).
- Check and adjust height of cut and height of groom as necessary.

- From 1 side of the groomer reel, slide a brush into each groove around the full length of the groomer reel ([Figure 18](#)).

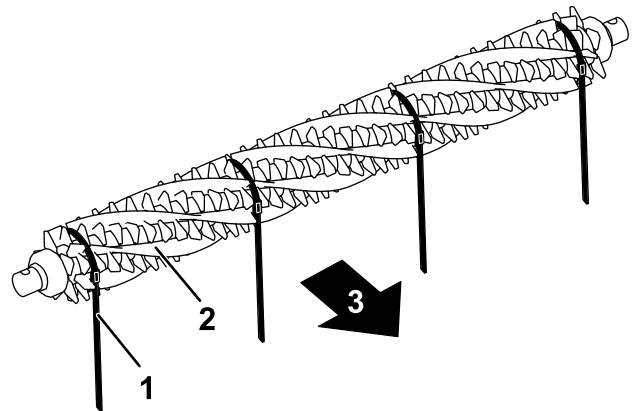

g227786

Figure 18

22 inch groomer shown

- | | |
|----------|---------------------------|
| 1. Strap | 3. Toward rear of machine |
| 2. Brush | |

Installing the Broomer Kit

Part Number	Broomer Kit
132-7115	18-inch Broomer Kit
132-7125	22-inch Broomer Kit
133-8222	27-inch Broomer Kit

- Obtain an optional broomer kit for groomer blade cartridges appropriate for your needs and cutting unit; refer to the table above.
- Loosen the groomer blade-retaining nuts on each end of the groomer shaft ([Figure 17](#)).

- Verify that the brushes are seated in the groomer blade slots ([Figure 17](#) and [Figure 19](#)).

- Subtract the desired (.75 inch or 19 mm) spring length from the current spring length, and divide this difference by 0.06 inches to determine how many washers you need to add to achieve the desired spring length.

11

Installing the Angled Fitting

For Reelmaster 3550 and 3555 Machines—#1 Front, Center Cutting Location and Kit Model 133-0150 Only

Parts needed for this procedure:

1	Hydraulic fitting—45° (Part No. 340-101; sold separately)
---	---

Procedure

Important: For Reelmaster 3550 and 3555 machines—#1 front, center cutting location and kit Model 133-0150 only; order 45° hydraulic fitting (Part No. 340-101) and follow the procedure below.

⚠ WARNING

Hydraulic fluid escaping under pressure can penetrate skin and cause injury.

- Seek immediate medical attention if fluid is injected into skin. Injected fluid must be surgically removed within a few hours by a doctor.
- Ensure that all hydraulic-fluid hoses are in good condition, and all that the hydraulic connections and fittings are tight before applying pressure to the hydraulic system.
- Keep your body and hands away from pinhole leaks or nozzles that eject high-pressure hydraulic fluid.
- Use cardboard or paper to find hydraulic leaks.
- Safely relieve all pressure in the hydraulic system before performing any work on the hydraulic system.

- Remove the hydraulic hose from the hydraulic fitting on the motor.

- Remove the 2 O-rings on the new 45° fitting, lubricate them with grease, and install them on the fitting.
- Remove the existing fitting.
- Install the new 45° fitting, positioning the fitting with the angle of the fitting as shown in [Figure 21](#). Torque the fitting to 47 to 58 N·m (35 to 43 ft-lb).

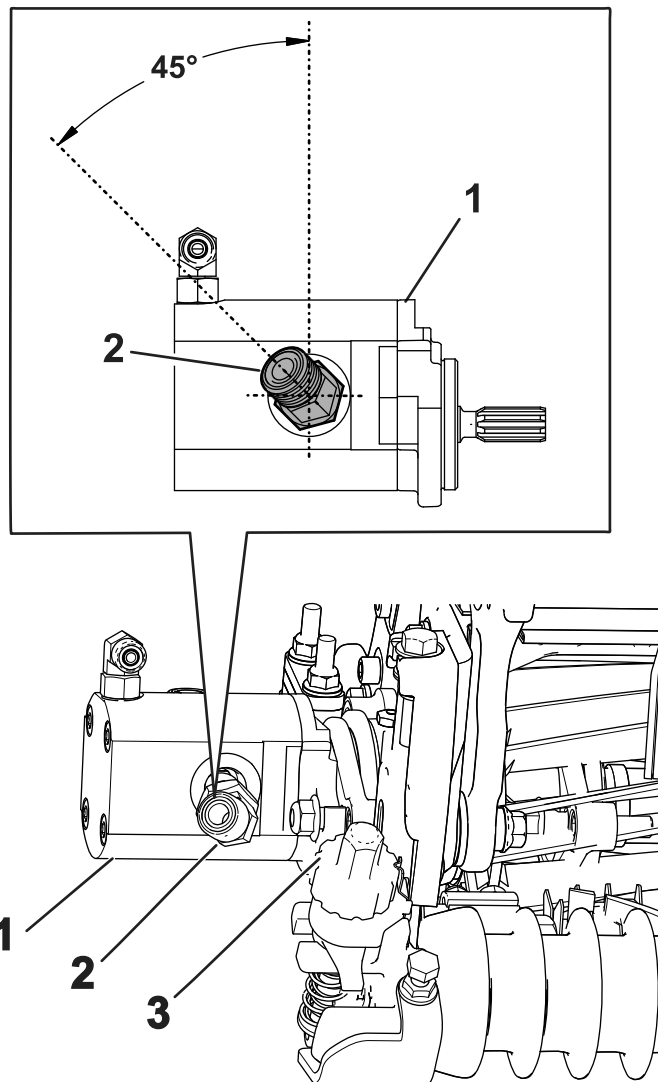

Figure 21

g190850

- Cutting unit motor
- 45° fitting
- Groomer adjuster

- Connect the hydraulic hose into the new fitting; torque the hose fitting to 40 to 64 N·m (37 to 47 ft-lb).

Note: Ensure that the fitting is positioned so that the hose does not contact the groomer adjuster.

Operation

Introduction

Grooming is performed in the turf canopy above the soil level. Grooming promotes vertical growth of grass plants, reduces grain, and severs stolons, producing a denser turf. Grooming produces a more uniform and tighter playing surface for faster and truer action of the golf ball.

Grooming should not be considered as a replacement for verticutting. Verticutting is generally a more rigorous and periodic treatment that can temporarily damage the playing surface, while grooming is a routine and gentler treatment designed to manicure the turf.

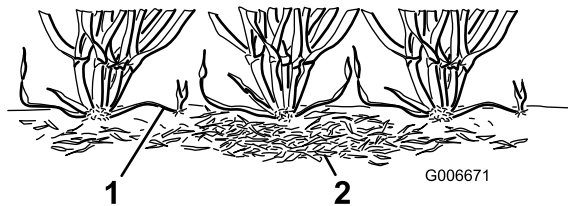

Figure 22

1. Grass runners (stolons) 2. Thatch

Grooming brushes are less intrusive than conventional grooming blades when adjusted to lightly contact the turf canopy. Brushing may be better for the ultra-dwarf cultivars, since these grass types have an upright growth pattern and do not fill in well through horizontal growth. Brushes can injure leaf tissue if they are set to penetrate too deeply into the canopy.

Groomer blades should never penetrate the soil. They are effective in cutting runners and removing thatch.

Because grooming injures leaf tissue, avoid grooming during periods of high stress. Cool season species, such as creeping bent grass and annual blue grass, should not be groomed during high-temperature (and high-humidity) periods in midsummer.

Many variables affect the performance of grooming, including the following:

- The time of the year (i.e., the growing season) and the weather pattern
- The general condition of the grass
- The frequency of grooming/cutting—both how many cuttings per week and how many passes per cutting
- The height-of-cut setting on the main reel
- The height/depth setting on the grooming reel
- How long the grooming reel has been in use

- The type of grass
- The overall management program (i.e., irrigation, fertilizing, spraying, coring, overseeding, etc.)
- Traffic
- Stress periods (i.e., high temperatures, high humidity, unusually high traffic)

These factors can vary from fairway to fairway. Inspect the mowing area frequently and change the grooming practice as needed.

Note: Using the groomer reel improperly or too aggressively (i.e., too deep or too frequent grooming) may unnecessarily stress the turf, causing severe turf damage. Use the groomer cautiously.

Note: Continue changing the direction of cut whenever you use the groomer. This enhances the effects of the grooming.

Note: Operate the groomer in a straight line as much as possible. Use caution when turning while operating the groomer.

Adjusting the Groomer Height

1. Park the machine on a clean and level surface, lower the cutting units completely to the ground, shut off the engine, engage the parking brake, and remove the key.
2. Make sure that the rollers are clean and the cutting unit is set to the desired height-of-cut (see your cutting unit *Operator's Manual*).
3. Rotate the quick-up levers (Figure 23) to the ENGAGED position (the handle points toward the front of the cutting unit).

Important: Use the Height-of-Cut (HOC) and Height-of-Groom (HOG) recommended range chart for setting the gauge bar.

4. At 1 end of the groomer reel, measure the distance from the lowest tip of the groomer blade to the working surface (Figure 23). Turn the height adjuster knob (Figure 23) to raise or lower the groomer blade tip to the desired height.

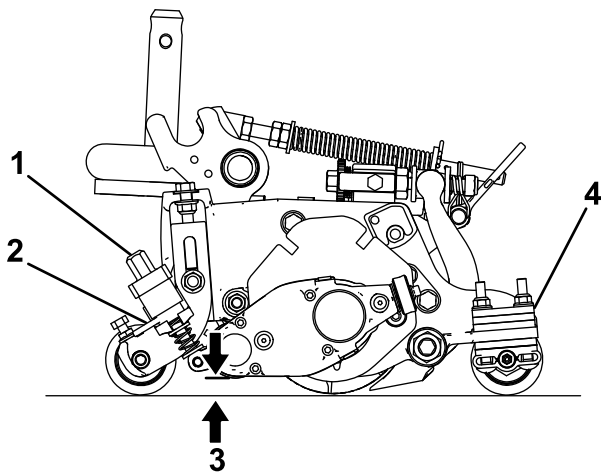

g346928

Figure 23

- | | |
|-------------------------|---|
| 1. Height adjuster knob | 3. Groomer height (HOG) |
| 2. Quick-up lever | 4. Number of rear roller spacers (below side plate pad) |

5. Repeat step 4 at the opposite end of the groomer, then check the setting on the first side of groomer.

The height setting on both ends of the groomer should be identical. Adjust the height as required.

Height-of-Cut (HOC) and Height-of-Groom (HOG) Recommended Range

Height-of-Cut (mm)	Height-of-Cut (inch)	Number of Rear Roller Spacers	Recommended HOG = HOC - Groomer Engagement (mm)	Recommended HOG = HOC - Groomer Engagement (inch)
6.3	0.250	0	3.1 to 6.3	0.125 to 0.250
9.5	0.375	0	4.7 to 9.5	0.187 to 0.375
9.5	0.375	1	4.7 to 9.5	0.187 to 0.375
12.7	0.500	0	6.3 to 12.7	0.250 to 0.500
12.7	0.500	1	6.3 to 12.7	0.250 to 0.500
12.7	0.500	2	6.3 to 9.5	0.250 to 0.375
15.8	0.625	0	9.5 to 15.8	0.375 to 0.625
15.8	0.625	1	9.5 to 15.8	0.375 to 0.625
15.8	0.625	2	9.5 to 12.7	0.375 to 0.500
19.0	0.750	1	12.7 to 19.0	0.500 to 0.750
19.0	0.750	2	12.7 to 19.0	0.500 to 0.750
19.0	0.750	3	12.7 to 15.8	0.500 to 0.625
22.2	0.875	1	15.8 to 22.2	0.625 to 0.875
22.2	0.875	2	15.8 to 22.2	0.625 to 0.875
22.2	0.875	3	15.8 to 19.0	0.625 to 0.750
25.4	1.00	2*	19.0 to 25.4	0.750 to 1.00
25.4	1.00	3	19.0 to 25.4	0.750 to 1.00
25.4	1.00	4	19.0 to 22.2	0.750 to 0.875

Note: Maximum HOG recommended is half the HOC to 6 mm (1/4 inch) maximum engagement

*Move the groomer front height-of-cut (HOC) bracket to the bottom (cutting unit location) side-plate hole.

Changing the Groomer Operating Direction

The groomer has 3 settings: NEUTRAL (N), FORWARD (F), and REVERSE (R). To change the direction of the groomer, turn the knob at the end of the groomer drive box and align the desired position with the adjustment notch.

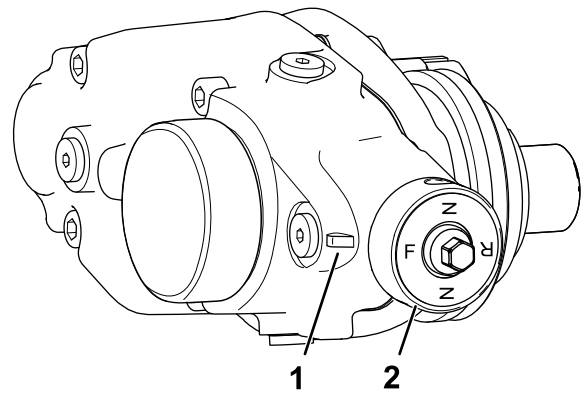

Figure 24

1. Adjustment notch 2. Knob

g302776

Testing the Groomer Performance

Important: Improper or over-aggressive use of the grooming reel (i.e., too deep or too frequent grooming) may cause unnecessary stress on the turf, leading to severe damage. Use the groomer cautiously.

⚠ DANGER

Contact with the reels or other moving parts can result in personal injury.

- Before making any adjustments to the cutting units, disengage the reels, set the parking brake, shut off the engine, and remove the key.
- Keep your hands and clothing away from the reels or other moving parts.

It is important to determine the performance of the groomer before putting it into regular use.

To determine the proper height/depth setting for quality grooming, do the following:

1. Set the main cutting reels to the height-of-cut setting that you would normally use without the grooming reel. Use a Wiehle roller on the front and a full roller on the rear.
Note: The amount of grass removed is a key indicator in determining the height/depth setting of the grooming reel.
2. Set each of the grooming reels to the desired height setting.
3. Examine the test area and determine if the groomed areas gives the desired results. If not, increase or decrease the height of the groomers and make another test pass.

Check the test area 2 or 3 days after the first grooming for general condition and damage. If the groomed areas are turning yellow and brown, and the non-groomed areas are green, then the grooming was too aggressive.

Transporting the Machine

When you wish to mow without the groomer or need to transport the machine, move the quick-up lever to the TRANSPORT position (Figure 25).

Note: This moves the groomer reel into a raised position.

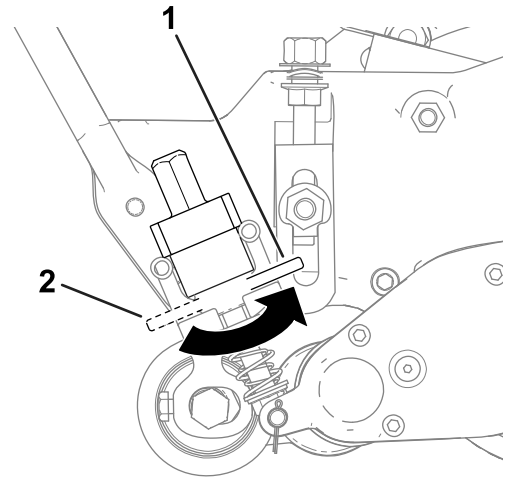

Figure 25

1. TRANSPORT position 2. OPERATION position

g287375

Maintenance

Changing the Gearbox Lubricant

Service Interval
After the first 100 hours
Every 500 hours / Yearly (Whichever comes first)

1. Clean the external surfaces of the groomer housing.

Important: Ensure that there is no dirt or clippings on the outside of the groomer housing; if debris gets inside of the groomer it can damage the gearbox.

2. Remove the drain plug on the bottom of the housing (Figure 28).
3. Remove the fill plug on the side of the housing and loosen the air-vent plug on the top so air can pass through (Figure 28).
4. Align a suitable container beneath the oil-drain port to catch drained oil.
5. Tip the cutting unit back onto the kickstand until the drain port is at the bottom to ensure complete drainage (Figure 26).

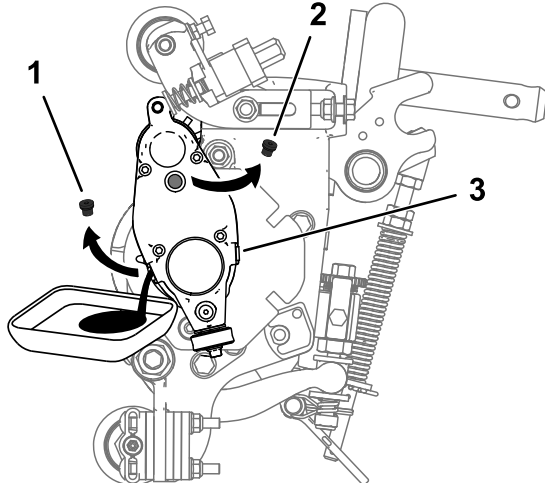

Figure 26

1. Remove the drain plug from the drain port.
2. Remove the fill plug from the fill port.
3. Loosen the air-vent plug.

6. Rock the cutting unit back and forth to ensure complete drainage. When the oil is completely drained, place the cutting unit on a level surface.
7. Install the drain plug.

8. Use the included syringe (Part No. 137-0872) to fill the drive box with 80-90W oil. Fill with 50 cc for 5-inch reels or 90 cc for 7-inch reels.

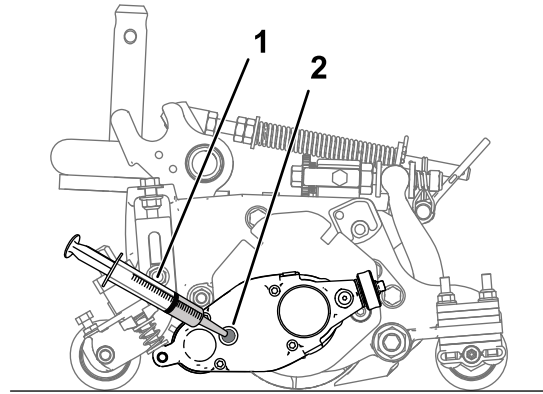

Figure 27

1. Syringe with 80-90W oil
2. Fill port

9. Install the fill plug and tighten the air-vent plug.
10. Torque all plugs to 3.62 to 4.75 N·m (32 to 42 in·lb).

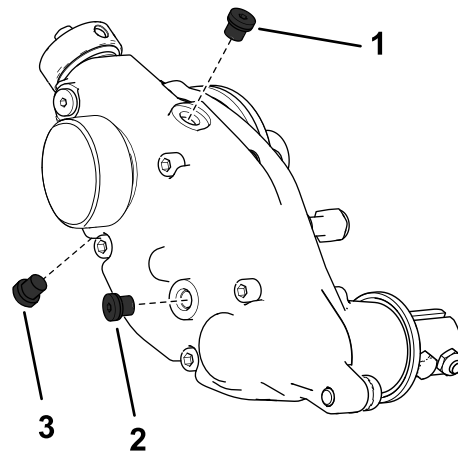

Figure 28

Right side groomer box shown

1. Air-vent plug
2. Fill plug
3. Drain plug

Removing the Groomer Drive Box

Note: Retain all removed parts for later installation unless otherwise stated.

Important: If you have any issues removing the groomer drive box, refer to your traction unit *Service Manual* or contact your authorized BOSS distributor.

1. Remove the cap from the groomer.
2. Remove the clamp bolts connecting the groomer to the drive box (Figure 16).
3. Remove the shoulder bolt and hardened washer connecting the groomer drive box to the adjuster arm (Figure 29).

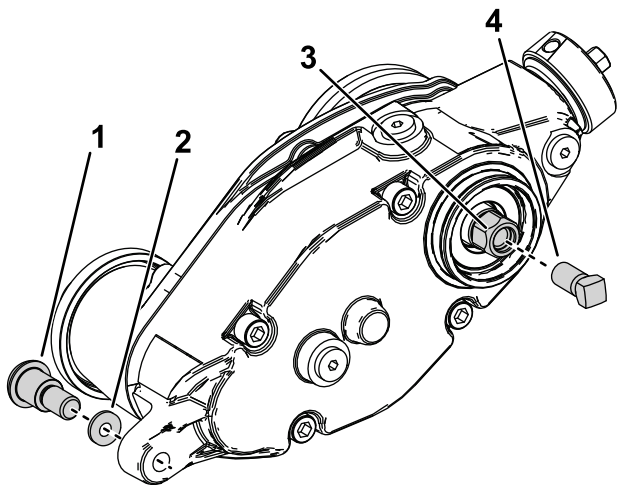

Figure 29

g346932

- | | |
|--------------------|---------------------------|
| 1. Shoulder bolt | 3. Groomer drive hex-head |
| 2. Hardened washer | 4. Reinforcement screw |

4. Restrain the reel for removal; refer to [Restraining the Reel for Removing Threaded Inserts](#) (page 19).
5. Install the reinforcement screw (Part No. 1-803022—sold separately) to the internal threads of the groomer drive hex head and torque to 13.5 N·m (120 in-lb) as shown in Figure 29.
6. Remove the groomer drive box from the cutting reel by turning the groomer drive hex-head (Figure 29).

Important: If the groomer drive box is installed on the right side of a cutting unit, turn the groomer drive hex-head counter-clockwise (right-hand thread) to remove the drive-box shaft from cutting unit.

Important: If the groomer drive box is installed on the left side of a cutting unit,

turn the groomer drive hex-head clockwise (left-hand thread) to remove drive-box shaft from cutting unit

Important: You must use a 6-point socket with heavy wall.

Cleaning the Grooming Reel

Service Interval: After each use

Clean off the grooming reel after using it by spraying it with water. Do not direct the water stream directly at the groomer bearing seals. Do not permit the grooming reel to stand in water so that the components rust.

Inspecting the Blades

Service Interval: Before each use or daily

Inspect the grooming-reel blades frequently for damage and wear. Straighten bent blades with a pliers and replace worn blades. When inspecting the blades, check to see that nuts on the right and left blade-shaft ends are tight.

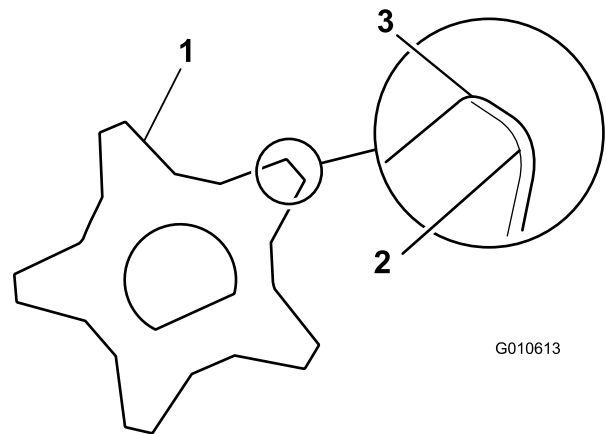

Figure 30

G010613

g010613

- | | |
|-------------------------|----------------|
| 1. Grooming blade | 3. Sharp edges |
| 2. Dull (rounded) edges | |

Restraining the Reel

⚠ WARNING

The cutting reel blades are sharp and capable of amputating hands and feet.

- Keep your hands and feet outside of the reel.
- Ensure that the reel is restrained before servicing it.

Restraining the Reel for Removing Threaded Inserts

1. Loosen the shield-bolt on the left side of the cutting unit and raise the rear shield (Figure 31).
2. Insert a long-handled pry bar (recommended 3/8 x 12 inches with a screwdriver handle) through the back of the cutting reel, closest to the side of the cutting unit that you will be torquing (Figure 31).
3. Place the pry bar against the weld side of the reel support plate (Figure 31).

Note: Insert the pry bar between the top of the reel shaft and the backs of 2 reel blades so that the reel will not move.

Important: Do not contact the cutting edge of any blades with the pry bar; this may damage the cutting edge and/or cause a high blade.

Important: The insert on the left side of the cutting unit has left-hand threads. The insert on the right side of the cutting unit has right-hand threads.

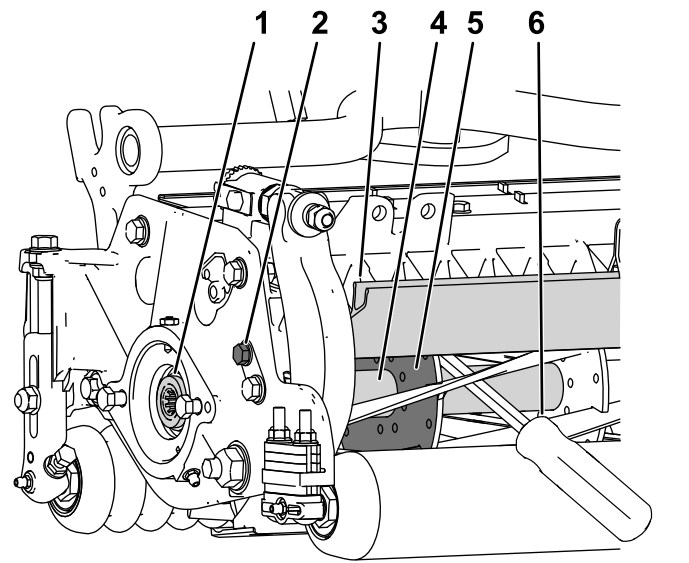

g280383

Figure 31

- | | |
|--------------------------------|--|
| 1. Threaded insert for removal | 4. Reel shaft |
| 2. Loosen the shield bolt. | 5. Reel support plate |
| 3. Rear shield | 6. Pry bar inserted along the weld side of the reel support plate. |
-
4. Rest the handle of the pry bar against the rear roller.
 5. Complete the removal of the threaded insert while ensuring that the pry bar stays in place, then remove the pry bar.
 6. Lower the rear shield and tighten the shield-bolt.

Restraining the Reel for Installing Threaded Inserts

1. Insert a long-handled pry bar (recommended 3/8 x 12 inches with a screwdriver handle) through the front of the cutting reel, closest to the side of the cutting unit that you will be torquing (Figure 32).
2. Place the pry bar against the weld side of the internal cutting reel reinforcement (Figure 32).

Note: The pry bar should contact a blade at the front, the reel shaft, and a blade at the back of the reel, locking it in place.

Important: Do not contact the cutting edge of any blades with the pry bar; this may damage the cutting edge and/or cause a high blade.

Important: The insert on the left side of the cutting unit has left-hand threads. The insert on the right side of the cutting unit has right-hand threads.

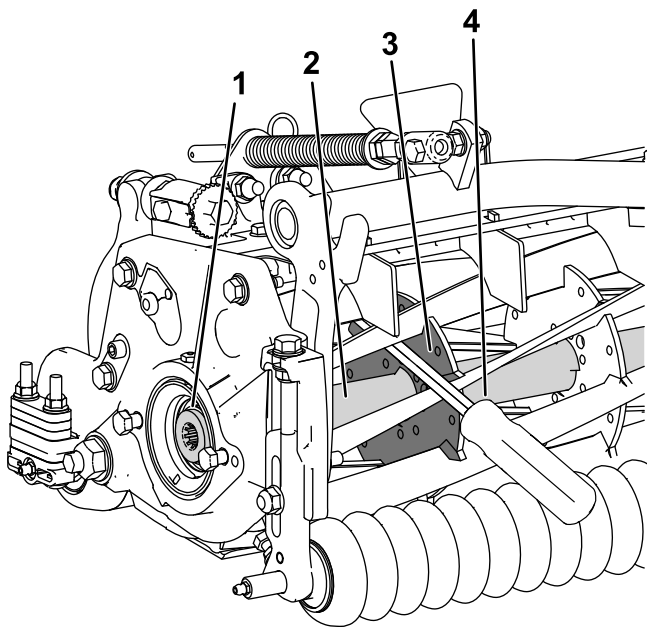

g280384

Figure 32

- | | |
|-------------------------------------|-------------------------------|
| 1. Threaded insert for installation | 3. Weld side of support plate |
| 2. Reel shaft | 4. Pry bar |

3. Rest the handle of the pry bar against the roller
4. Per the insert's installation instructions and torque requirements, complete the installation of the threaded insert while ensuring that the pry bar stays in place, then remove the pry bar.

Declaration of Incorporation

The Toro Company, 8111 Lyndale Ave. South, Bloomington, MN, USA declares that the following unit(s) conform(s) to the directives listed, when installed in accordance with the accompanying instructions onto certain Toro models as indicated on the relevant Declarations of Conformity.

Model No.	Serial No.	Product Description	Invoice Description	General Description	Directive
03763	321000000 and Up and Up	Universal Groomer Drive Kit, Reelmaster 18-inch or 22-inch EdgeSeries Cutting Units with 5-inch Reel	5IN RM UNIVERSAL/ BI-DIRECTIONAL GROOMER	Groomer Kit	2006/42/EC
03768	321000000 and Up and Up	Universal Groomer Drive Kit, Reelmaster 3575, 5010, 5010-H, and 7000 Series 22-inch or 27-inch Cutting Units with 7" Reel	7IN RM UNIVERSAL/ BI-DIRECTIONAL GROOMER	Groomer Kit	2006/42/EC

Relevant technical documentation has been compiled as required per Part B of Annex VII of 2006/42/EC.

We will undertake to transmit, in response to requests by national authorities, relevant information on this partly completed machinery. The method of transmission shall be electronic transmittal.

This machinery shall not be put into service until incorporated into approved Toro models as indicated on the associated Declaration of Conformity and in accordance with all instructions, whereby it can be declared in conformity with all relevant Directives.

Certified:



Tom Langworthy
Engineering Director
8111 Lyndale Ave. South
Bloomington, MN 55420, USA
October 6, 2022

Authorized Representative:

Marcel Dutrieux
Manager European Product Integrity
Toro Europe NV
Nijverheidsstraat 5
2260 Oevel
Belgium

UK Declaration of Incorporation

The Toro Company, 8111 Lyndale Ave. South, Bloomington, MN, USA declares that the following unit(s) conform(s) to the directives listed, when installed in accordance with the accompanying instructions onto certain Toro models as indicated on the relevant Declarations of Conformity.

Model No.	Serial No.	Product Description	Invoice Description	General Description	Regulation
03763	321000000 and Up and Up	Universal Groomer Drive Kit, Reelmaster 18-inch or 22-inch EdgeSeries Cutting Units with 5-inch Reel	5IN RM UNIVERSAL/BI-DIRECTIONAL GROOMER	Groomer Kit	S.I. 2008 No. 1597
03768	321000000 and Up and Up	Universal Groomer Drive Kit, Reelmaster 3575, 5010, 5010-H, and 7000 Series 22-inch or 27-inch Cutting Units with 7" Reel	7IN RM UNIVERSAL/BI-DIRECTIONAL GROOMER	Groomer Kit	S.I. 2008 No. 1597

Relevant technical documentation has been compiled as required per Schedule 10 of S.I. 2008 No. 1597.

We will undertake to transmit, in response to requests by national authorities, relevant information on this partly completed machinery. The method of transmission shall be electronic transmittal.

This machinery shall not be put into service until incorporated into approved Toro models as indicated on the associated Declaration of Conformity and in accordance with all instructions, whereby it can be declared in conformity with all relevant Directives.

This declaration has been issued under the sole responsibility of the manufacturer.
The object of the declaration is in conformity with relevant UK legislation.



Tom Langworthy
Engineering Director
8111 Lyndale Ave. South
Bloomington, MN 55420, USA
October 7, 2022

Authorized Representative:

Marcel Dutrieux
Manager European Product Integrity
Toro U.K. Limited
Spellbrook Lane West
Bishop's Stortford
CM23 4BU
United Kingdom

EEA/UK Privacy Notice

Toro's Use of Your Personal Information

The Toro Company ("Toro") respects your privacy. When you purchase our products, we may collect certain personal information about you, either directly from you or through your local Toro company or dealer. Toro uses this information to fulfil contractual obligations - such as to register your warranty, process your warranty claim or to contact you in the event of a product recall - and for legitimate business purposes - such as to gauge customer satisfaction, improve our products or provide you with product information which may be of interest. Toro may share your information with our subsidiaries, affiliates, dealers or other business partners in connection these activities. We may also disclose personal information when required by law or in connection with the sale, purchase or merger of a business. We will never sell your personal information to any other company for marketing purposes.

Retention of your Personal Information

Toro will keep your personal information as long as it is relevant for the above purposes and in accordance with legal requirements. For more information about applicable retention periods please contact legal@toro.com.

Toro's Commitment to Security

Your personal information may be processed in the US or another country which may have less strict data protection laws than your country of residence. Whenever we transfer your information outside of your country of residence, we will take legally required steps to ensure that appropriate safeguards are in place to protect your information and to make sure it is treated securely.

Access and Correction

You may have the right to correct or review your personal data, or object to or restrict the processing of your data. To do so, please contact us by email at legal@toro.com. If you have concerns about the way in which Toro has handled your information, we encourage you to raise this directly with us. Please note that European residents have the right to complain to your Data Protection Authority.



The Toro Warranty

Two-Year or 1,500 Hours Limited Warranty

Conditions and Products Covered

The Toro Company warrants your Toro Commercial product ("Product") to be free from defects in materials or workmanship for 2 years or 1,500 operational hours*, whichever occurs first. This warranty is applicable to all products with the exception of Aerators (refer to separate warranty statements for these products). Where a warrantable condition exists, we will repair the Product at no cost to you including diagnostics, labor, parts, and transportation. This warranty begins on the date the Product is delivered to the original retail purchaser.

* Product equipped with an hour meter.

Instructions for Obtaining Warranty Service

You are responsible for notifying the Commercial Products Distributor or Authorized Commercial Products Dealer from whom you purchased the Product as soon as you believe a warrantable condition exists. If you need help locating a Commercial Products Distributor or Authorized Dealer, or if you have questions regarding your warranty rights or responsibilities, you may contact us at:

Toro Commercial Products Service Department
8111 Lyndale Avenue South
Bloomington, MN 55420-1196

952-888-8801 or 800-952-2740
E-mail: commercial.warranty@toro.com

Owner Responsibilities

As the product owner, you are responsible for required maintenance and adjustments stated in your *Operator's Manual*. Repairs for product issues caused by failure to perform required maintenance and adjustments are not covered under this warranty.

Items and Conditions Not Covered

Not all product failures or malfunctions that occur during the warranty period are defects in materials or workmanship. This warranty does not cover the following:

- Product failures which result from the use of non-Toro replacement parts, or from installation and use of add-on, or modified non-Toro branded accessories and products.
- Product failures which result from failure to perform recommended maintenance and/or adjustments.
- Product failures which result from operating the Product in an abusive, negligent, or reckless manner.
- Parts consumed through use that are not defective. Examples of parts which are consumed, or used up, during normal Product operation include, but are not limited to, brake pads and linings, clutch linings, blades, reels, rollers and bearings (sealed or greasable), bed knives, spark plugs, castor wheels and bearings, tires, filters, belts, and certain sprayer components such as diaphragms, nozzles, flow meters, and check valves.
- Failures caused by outside influence, including, but not limited to, weather, storage practices, contamination, use of unapproved fuels, coolants, lubricants, additives, fertilizers, water, or chemicals.
- Failure or performance issues due to the use of fuels (e.g. gasoline, diesel, or biodiesel) that do not conform to their respective industry standards.
- Normal noise, vibration, wear and tear, and deterioration. Normal "wear and tear" includes, but is not limited to, damage to seats due to wear or abrasion, worn painted surfaces, scratched decals or windows.

Countries Other than the United States or Canada

Customers who have purchased Toro products exported from the United States or Canada should contact their Toro Distributor (Dealer) to obtain guarantee policies for your country, province, or state. If for any reason you are dissatisfied with your Distributor's service or have difficulty obtaining guarantee information, contact your Authorized Toro Service Center.

Parts

Parts scheduled for replacement as required maintenance are warranted for the period of time up to the scheduled replacement time for that part. Parts replaced under this warranty are covered for the duration of the original product warranty and become the property of Toro. Toro will make the final decision whether to repair any existing part or assembly or replace it. Toro may use remanufactured parts for warranty repairs.

Deep Cycle and Lithium-Ion Battery Warranty

Deep cycle and Lithium-Ion batteries have a specified total number of kilowatt-hours they can deliver during their lifetime. Operating, recharging, and maintenance techniques can extend or reduce total battery life. As the batteries in this product are consumed, the amount of useful work between charging intervals will slowly decrease until the battery is completely worn out. Replacement of worn out batteries, due to normal consumption, is the responsibility of the product owner. Note: (Lithium-Ion battery only): Refer to the battery warranty for additional information.

Lifetime Crankshaft Warranty (ProStripe 02657 Model Only)

The ProStripe which is fitted with a genuine Toro Friction Disc and Crank-Safe Blade Brake Clutch (integrated Blade Brake Clutch (BBC) + Friction Disc assembly) as original equipment and used by the original purchaser in accordance with recommended operating and maintenance procedures, are covered by a Lifetime Warranty against engine crankshaft bending. Machines fitted with friction washers, Blade Brake Clutch (BBC) units and other such devices are not covered by the Lifetime Crankshaft Warranty.

Maintenance is at Owner's Expense

Engine tune-up, lubrication, cleaning and polishing, replacement of filters, coolant, and completing recommended maintenance are some of the normal services Toro products require that are at the owner's expense.

General Conditions

Repair by an Authorized Toro Distributor or Dealer is your sole remedy under this warranty.

The Toro Company is not liable for indirect, incidental or consequential damages in connection with the use of the Toro Products covered by this warranty, including any cost or expense of providing substitute equipment or service during reasonable periods of malfunction or non-use pending completion of repairs under this warranty. Except for the Emissions warranty referenced below, if applicable, there is no other express warranty. All implied warranties of merchantability and fitness for use are limited to the duration of this express warranty.

Some states do not allow exclusions of incidental or consequential damages, or limitations on how long an implied warranty lasts, so the above exclusions and limitations may not apply to you. This warranty gives you specific legal rights, and you may also have other rights which vary from state to state.

Note Regarding Emissions Warranty

The Emissions Control System on your Product may be covered by a separate warranty meeting requirements established by the U.S. Environmental Protection Agency (EPA) and/or the California Air Resources Board (CARB). The hour limitations set forth above do not apply to the Emissions Control System Warranty. Refer to the Engine Emission Control Warranty Statement supplied with your product or contained in the engine manufacturer's documentation.