



27in Rotary Cutting Unit Groundsmaster® 3500-D/4500-D/4700-D

Model No. 30827 - 240003001 and up.

Parts Catalog

Ordering Replacement Parts

To order replacement parts, please supply the part number, the quantity, and the description of each part desired.

Understanding Reference Numbers

Each Identified part in an illustration has a reference number. The reference number for a part also appears in the parts list, along with other information about the part.

This catalog uses two special reference number formats, one to indicate parts in a service assembly and another to indicate the quantity of a given part in an illustration.

Service Assembly Reference Numbers

Parts in service assemblies have reference numbers in the form a:b. The a represents the reference number of the entire service assembly and the b represents a sequential number unique to each part within the service assembly.

For example, a wheel assembly might be identified by reference number 6, the tire by 6:1, the valve by 6:2, and the wheel by 6:3. When you order the assembly identified by reference number 6, you receive all parts identified by reference numbers 6:1, 6:2, and 6:3. However, you may also order any part individually. Reference numbers of this type appear in illustrations and in part lists.

Reference Numbers Indicating Quantity

In an illustration, if a reference number indicates more than one part, the reference number has the form nX y. The n represents the quantity of the part, the X is the multiplication symbol, and the y represents the reference number.

For example, in an illustration, the reference number 2X 37 means that two of the parts identified by reference number 37 are indicated.

Contents

Description	Page	Description	Page
Roller Assembly 3	Housing and Blade Assembly 6
Roller Assembly No. 107-1996 4	Spindle Assembly No. 100-5700 7
Height-Of-Cut Bracket Assembly 5		

Part Description Abbreviations

Part descriptions in this catalog may include the following abbreviations.

AR. as required	HYD. hydraulic
ASM. assembly	INC. incorporated
CARR. carriage	LH. left hand
DEG. degrees	NI. nylon insert
FH. flat head	PPH. phillips pan head
GA. gauge	PTH. phillips truss head
HF. hex flange	PTO. power take off
HH. hex head	RH. right hand
HHF. hex head flange	SFH. slotted fillister head
HHFTF. hex head flange thread forming	SHH. slotted hex head
HJ. hex jam	SHWH. slotted hex washer head
HLH. hex lag head	SPH. slotted pan head
HOC. height-of-cut	SQH. square head
HS. hex	SRH. slotted round head
HSBH. hex socket button head	STD. standard
HSFH. hex socket flat head	TAP. self tapping
HS. hex socket head	TTH. torx truss head
HWH. hex washer head	WH. wing head
HWHTF. hex washer head thread forming	

Footnotes

- ❶ Optional Equipment

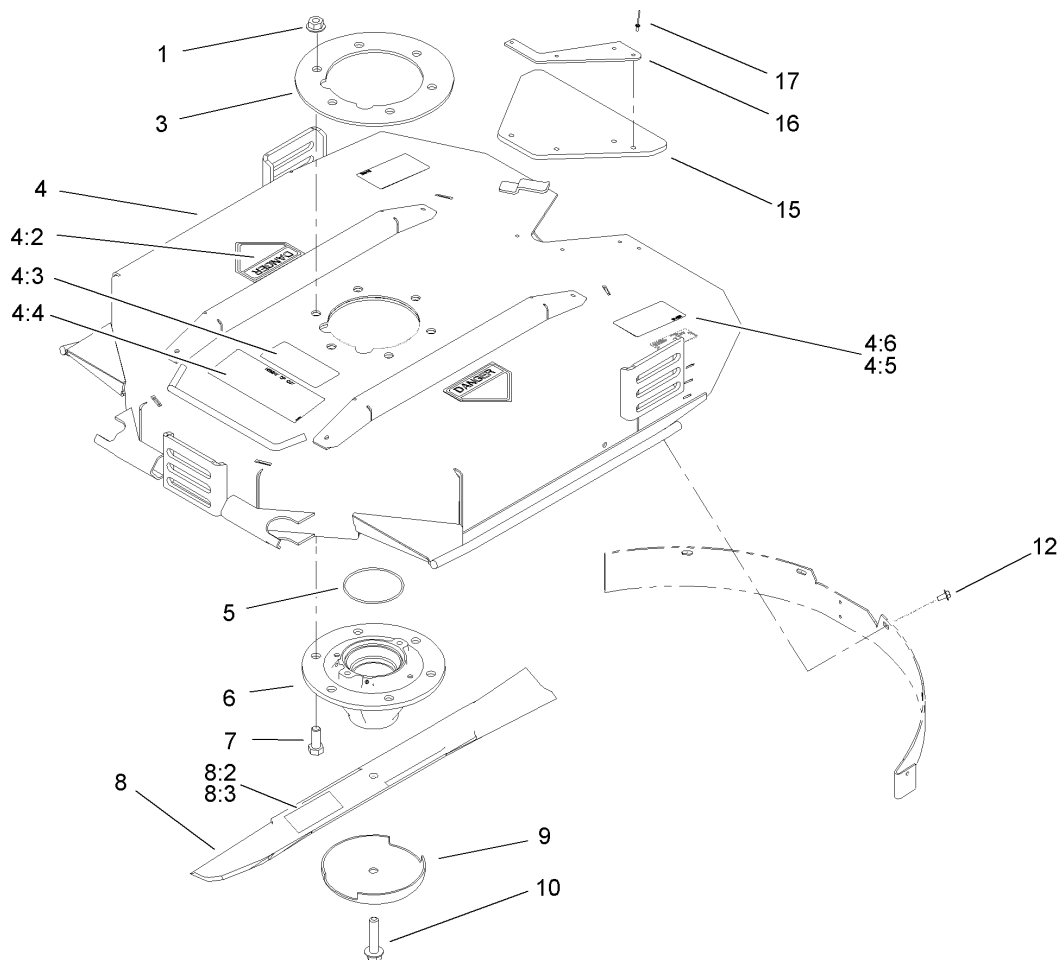

Housing and Blade Assembly

Ref	Part No.	Qty.	Description
1	32128-49	6	Nut-HHF
3	104-1051-03	1	Plate-Spindle
4	105-9180	1	Chamber ASM
4:2	43-8480	2	Decal-Danger
4:2	106-6753	2	Decal-Danger, Ce
4:3	93-7818	1	Decal-Torque, Blade Bolt
4:4	104-1086	1	Decal-HOC
4:5	104-4892	2	Decal-Warning, Guard
4:6	104-4893	2	Decal-Blank, Ce
5	237-161	1	O-Ring
6	100-5700	1	Spindle ASM
7	325-5	6	Screw-HH
8	105-9810-03	1	Blade-Angle Sail
●8	104-5183	1	Blade-High Lift (Optional)
8:2	107-1971	1	Decal-Warning
8:3	107-1972	1	Decal-Warning, Ce
9	72-9361	1	Cup-Scalp, Anti
10	92-5816	1	Bolt-Blade
12	46-8560	5	Screw-HHF
15	105-9173	1	Flap-Rubber
16	105-3954-03	1	Plate-Flap
17	3269-7	4	Rivet-Pop, Steel

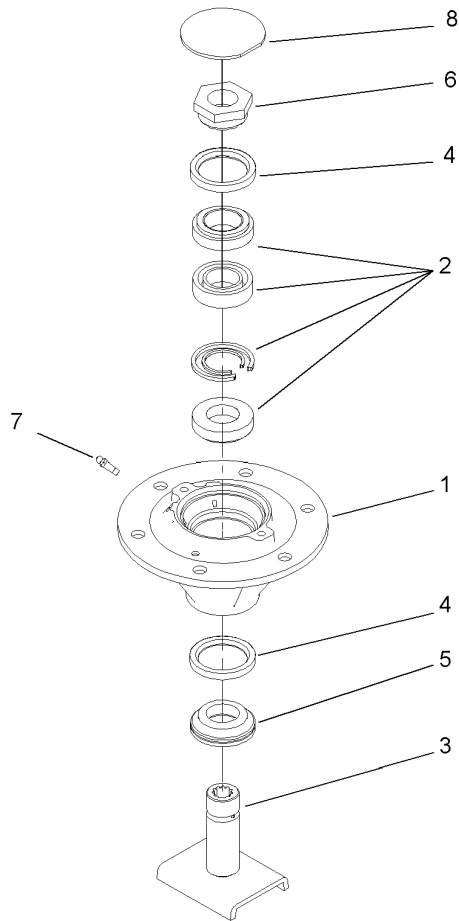

Spindle Assembly No. 100-5700

Ref	Part No.	Qty.	Description				
1	100-5701	1	Housing-Spindle				
2	100-5703	1	Spacer And Bearing ASM				
3	100-5705	1	Spindle Shaft ASM				
4	253-154	2	Seal-Oil				
5	69-6950	1	Spacer-Shaft, Spindle				
6	100-5709	1	Nut-Spindle, Special				
7	302-62	2	Fitting-Grease				
8	94-2703	1	Plug				

