



Count on it.

Operator's Manual

Workman® UTX-D Utility Vehicle

Model No. 08102—Serial No. 419000000 and Up

Model No. 08102BS—Serial No. 400000000 and Up

Model No. 08102TC—Serial No. 419000000 and Up

Model No. 08103—Serial No. 419000000 and Up

Model No. 08103BS—Serial No. 400000000 and Up

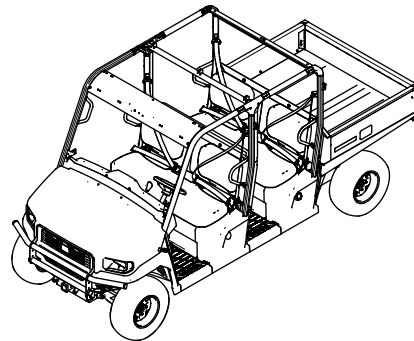
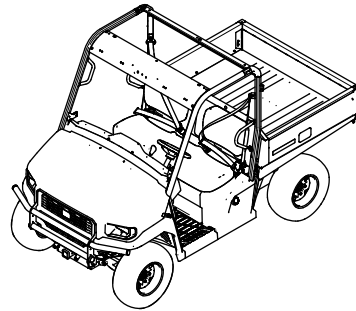

This product complies with all relevant European directives; for details, please see the separate product specific Declaration of Conformity (DOC) sheet.

It is a violation of California Public Resource Code Section 4442 or 4443 to use or operate the engine on any forest-covered, brush-covered, or grass-covered land unless the engine is equipped with a spark arrester, as defined in Section 4442, maintained in effective working order or the engine is constructed, equipped, and maintained for the prevention of fire.

The enclosed engine owner's manual is supplied for information regarding the US Environmental Protection Agency (EPA) and the California Emission Control Regulation of emission systems, maintenance, and warranty. Replacements may be ordered through the engine manufacturer.

If this machine is equipped with a telematics device, refer to your authorized Toro distributor for instructions to activate the device.

⚠ WARNING

**CALIFORNIA
Proposition 65 Warning**

Diesel engine exhaust and some of its constituents are known to the State of California to cause cancer, birth defects, and other reproductive harm.

Battery posts, terminals, and related accessories contain lead and lead compounds, chemicals known to the State of California to cause cancer and reproductive harm. Wash hands after handling.

Introduction

This utility vehicle is intended to be primarily used off-highway to transport people and material loads. Using this product for purposes other than its intended use could prove dangerous to you and bystanders.

Read this information carefully to learn how to operate and maintain your product properly and to avoid injury and product damage. You are responsible for operating the product properly and safely.

Visit www.Toro.com for product safety and operation training materials, accessory information, help finding a dealer, or to register your product.

Whenever you need service, genuine Toro parts, or additional information, contact an Authorized Service Distributor or Toro Customer Service and have the model and serial numbers of your product ready. **Figure 1** identifies the location of the model and serial numbers on the product. Write the numbers in the space provided.

Important: With your mobile device, you can scan the QR code on the serial number decal (if equipped) to access warranty, parts, and other product information.

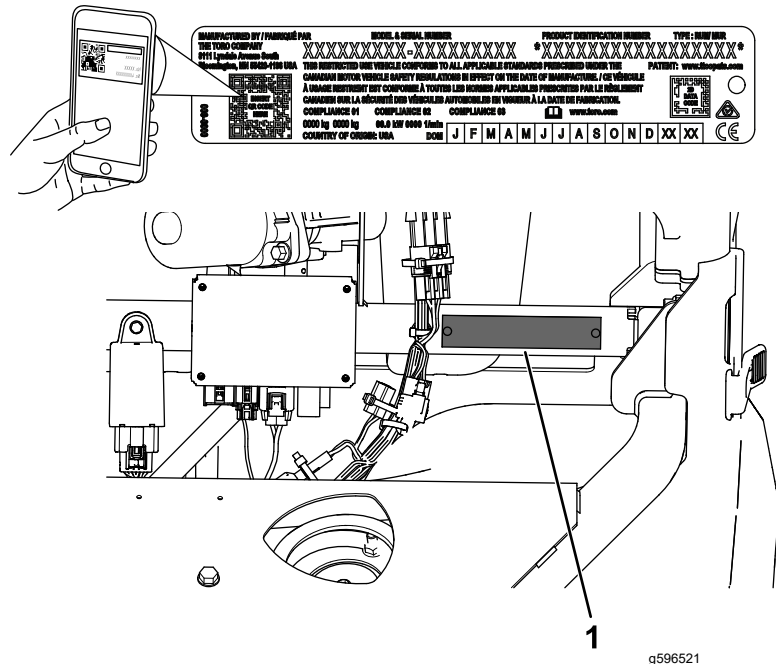

Figure 1

1. Model and serial number location

Model No. _____

Serial No. _____

This manual uses 2 words to highlight information. **Important** calls attention to special mechanical information and **Note** emphasizes general information worthy of special attention.

The safety-alert symbol (Figure 2) appears both in this manual and on the machine to identify important safety messages that you must follow to avoid accidents. This symbol will appear with the word **Danger**, **Warning**, or **Caution**.

- **Danger** indicates an imminently hazardous situation which, if not avoided, **will** result in death or serious injury.
- **Warning** indicates a potentially hazardous situation which, if not avoided, **could** result in death or serious injury.
- **Caution** indicates a potentially hazardous situation which, if not avoided, **may** result in minor or moderate injury.



Figure 2
Safety-alert symbol

g000502

Contents

Safety	4
General Safety	4
Safety and Instructional Decals	5
Setup	8
1 Installing the Steering Wheel.....	8
2 Connecting the Battery	9
3 Changing the Blinker Mode from United States (US) to European (EU)	10
4 Converting the Speedometer from mph to km/h.....	10
5 Checking the Fluid Levels and Tire Pressure	11
6 Installing the Rollover Protection System (ROPS)	11
7 Burnishing the Brakes.....	30
Product Overview	31
Controls	31
Specifications	37
Attachments/Accessories	37
Before Operation	38
Before Operation Safety	38
Performing Daily Maintenance.....	38
Checking the Tire Pressure.....	39
Adding Fuel	40
Breaking in a New Machine	40
During Operation	41
During Operation Safety	41
Operating the Cargo Bed	43
Starting the Engine	45
Driving the Machine	45
Using the Cruise Control	45
Adjusting the Ground Speed Governor	46
Stopping the Machine	46
Shutting Off the Engine	46
Using the 4-Wheel Drive/Differential Lock(s).....	47
Controlling the Engine Throttle While in the P (PARK) Position	48
Loading the Cargo Bed	49
After Operation	50
After Operation Safety	50
Hauling the Machine	50
Towing the Machine	51
Towing a Trailer	51
Maintenance	52
Maintenance Safety.....	52
Recommended Maintenance Schedule(s)	53
Daily Maintenance Checklist.....	55
Maintaining the Machine under Special Operating Conditions	55
Pre-Maintenance Procedures	56
Preparing the Machine for Maintenance.....	56
Raising the Machine	56
Accessing the Hood.....	57
Lubrication	58
Greasing the Machine.....	58

Safety

General Safety

This product is capable of causing personal injury. Always follow all safety instructions to avoid serious personal injury.

- Read and understand the contents of this *Operator's Manual* before you start the machine. Ensure that everyone using this product knows how to use it and understands the warnings.
- Carrying a heavy load with and/or adding attachments to the vehicle may affect its stability, depending on the amount and distribution of the weight.
- Use your full attention while operating the machine. Do not engage in any activity that causes distractions; otherwise, injury or property damage may occur.
- Do not put your hands or feet near moving components of the machine.
- Do not operate the machine without all guards and other safety protective devices in place and working on the machine.
- Keep bystanders and children out of the operating area. Never allow children under 16 to operate the machine unless they have obtained a state-issued motor vehicle driver's license.
- Stop and shut off the machine and remove the key before servicing or fueling.

Engine Maintenance	60
Engine Safety	60
Servicing the Air Cleaner	60
Servicing the Engine Oil.....	61
Checking and Adjusting the Alternator Belt.....	63
Calibrating the Throttle Actuator	64
Fuel System Maintenance	65
Changing the Fuel Filter/Water Separator	65
Checking the Fuel Lines and Connections.....	65
Electrical System Maintenance	66
Electrical System Safety	66
Servicing the Battery.....	66
Servicing the Fuses	69
Drive System Maintenance	70
Maintaining the Tires	70
Checking the Steering and Suspension Components	70
Checking/Adjusting the Front Wheel Alignment.....	71
Adjusting the Front Ride Height	72
Checking the Transaxle-Fluid Level	73
Changing the Transaxle Fluid	73
Checking the Front Differential Oil Level	74
Changing the Front Differential Oil	74
Cooling System Maintenance	75
Cooling System Safety	75
Checking the Engine-Coolant Level.....	75
Removing Debris from the Cooling System.....	75
Checking the Coolant Hoses	76
Changing the Engine Coolant	77
Brake Maintenance	77
Checking the Brakes.....	77
Checking the Brake-Fluid Level	78
Changing the Brake Fluid	78
Belt Maintenance	79
Servicing the Drive Belt.....	79
Cleaning	80
Washing the Machine	80
Storage	81
Storage Safety.....	81
Storing the Machine.....	81
Troubleshooting	82

Safety and Instructional Decals



Safety decals and instructions are easily visible to the operator and are located near any area of potential danger. Replace any decal that is damaged or missing.

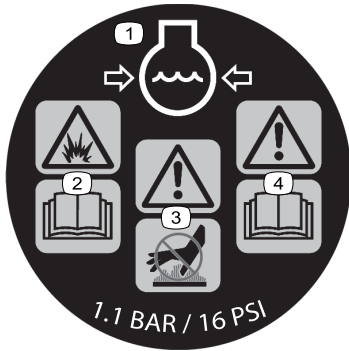

decal161-5218

161-5218

- | | |
|---|--|
| 1. Engine coolant under pressure | 3. Warning—do not touch the hot surface. |
| 2. Explosion hazard—read the <i>Operator's Manual</i> . | 4. Warning—read the <i>Operator's Manual</i> . |

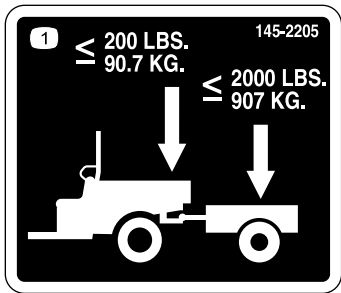

decal145-2205

145-2205

1. Do not exceed a tongue weight of 90.7 kg (200 lb); do not exceed a transport load of 907 kg (2,000 lb).



decal145-2215

145-2215

- | | |
|---|----------------------------------|
| 1. Warning—Read the <i>Operator's Manual</i> , wear a seat belt, avoid tipping the machine. | 2. Warning—do not drill or weld. |
|---|----------------------------------|



Battery Symbols

Some or all of these symbols are on your battery.

1. Explosion hazard
2. No fire, open flame, or smoking
3. Caustic liquid/chemical burn hazard
4. Wear eye protection.
5. Read the *Operator's Manual*.
6. Keep bystanders away from the battery.
7. Wear eye protection; explosive gases can cause blindness and other injuries.
8. Battery acid can cause blindness or severe burns.
9. Flush eyes immediately with water and get medical help fast.
10. Contains lead; do not discard



144-1144

decal144-1144

1. Runover/backover hazard—do not carry passengers.
2. Attention—read the *Operator's Manual*; maximum weight 567 kg (1,250 lb).

For Crew (4-Person) Models



144-2293

decal144-2293

1. Runover/backover hazard—do not carry passengers.
2. Attention—read the *Operator's Manual*; maximum weight 453 kg (1,000 lb).

For Standard (2-Person) Models



161-5426

decal161-5426

1. Warning—read the *Operator's Manual*.
2. Warning—all operators should be trained before operating the machine.
3. Warning—wear a helmet on rough or uneven terrain or at high speeds.
4. Warning—wear eye protection.
5. Warning—wear hearing protection (diesel models only).
6. Warning—do not wear open-toed shoes.
7. Collision hazard—do not operate the machine on public streets, roads, or highways.
8. Warning—do not allow people who are not at least 16 years old or without valid driver's licenses to operate the machine.
9. Warning—do not operate the machine under the influence of drugs or alcohol.
10. Falling hazard—do not carry passengers in the bed; do not carry extra passengers in between the seats.
11. Fire hazard—shut off the engine when adding fuel to the machine.
12. Warning—each rider must sit with their back against the seat, position their feet flat on the floor, and grasp the handholds.
13. Warning—shift the transmission lever to the P (PARK) position, turn the key to the OFF position, and remove the key before leaving the machine.

WORKMAN - UTX DIESEL MODELS: 08102, 08102TC, 08103										
1 F	1.65 BAR (24 PSI)	5	SAE 10W-30	2.3 L (2.4 qt)	135-4181	250	9	110-9049	-	500
2	≤ 226 kg (500 LBS) > 226 kg (500 LBS)	6	-	-	108-3810	250*	F	10	80W-90	0.15 L (5 oz)
3 R	1.65 BAR (24 PSI) 2.21 BAR (32 PSI)	7	145-2048	1.21 L (41 oz)	-	500	11	DOT 3	-	1000**
4	* **	8	145-7789	-	-	500	12	50% (ELC) ETHYLENE GLYCOL w/OAT 50% DISTILLED WATER	-	1000**

147-8166

decal147-8166

Note: * Replace more frequently in dusty or dirty conditions

** 1,000 hours or 5 years; whichever comes sooner

- | | | | |
|---|--------------------------|--------------------------------|-----------|
| 1. Front tire pressure | 5. Engine oil and filter | 9. Fuel filter/water separator | 13. Hours |
| 2. Rear tire pressure (varies depending on cargo load) | 6. Engine-air filter | 10. Front differential fluid | |
| 3. Rear tire pressure | 7. Transaxle fluid | 11. Brake fluid | |
| 4. Read the <i>Operator's Manual</i> before performing maintenance. | 8. Drive belt | 12. Engine coolant | |

1	3	5	8	10*	13	16	TEC-5004	20	TEC-5004 LOGIC
4WD ↑	4WD ↑	4WD ↓	(DIESEL & GAS)	10A	10A	10A	7.5A	10A	2A
2	4	6	*(GAS)	11*	14	TEC-5004	17	18	21
4WD ↓	4WD ↓	Fuel-pump		5A	10A	7.5A	Alarm	30A	10A
		7	9*	12	15	TEC-5004	19	22	23
		Starter	20A	TELEMATICS	25A	7.5A	Display and throttle	20A	10A
									24
									Horn

161-5445

decal161-5445

Note: * Gasoline models only

- | | |
|--|---|
| 1. Front differential lock and 4-wheel drive disengage relay | 13. Alternator, power steering, and speed sensor enable |
| 2. Front differential lock and 4-wheel drive engage relay | 14. Front and rear differentials |
| 3. Front differential lock disengage relay | 15. Cooling fan |
| 4. Front differential lock engage relay | 16. Position lights and turn-signal lights |
| 5. Rear differential lock engage relay | 17. Alarm |
| 6. Fuel-pump relay | 18. Power steering |
| 7. Starter relay | 19. Display and throttle |
| 8. Read the <i>Operator's Manual</i> for fuse information. | 20. Fuel-pump relay power |
| 9. Engine ignition power | 21. Salt spreader |
| 10. Engine—ECM power | 22. Bed lift |
| 11. Engine—vehicle-switch power | 23. Headlights and hazard lights |
| 12. USB/telematics | 24. Horn |

Setup

Note: Determine the left and right side of the machine from the normal operating position.

1

Installing the Steering Wheel

TC Models Only

Parts needed for this procedure:

1	Steering wheel
1	Cover

Procedure

1. If the cover is installed, remove it from the hub of the steering wheel.
2. Remove the locknut (1/2 inch) from the steering shaft.
3. Ensure that the front wheels are centered.
4. Slide the steering wheel onto the steering shaft.
5. Secure the steering wheel to the shaft using the previously removed locknut (1/2 inch) and tighten it to 24 to 30 N·m (18 to 22 ft-lb).
6. Install the cover onto the steering wheel.

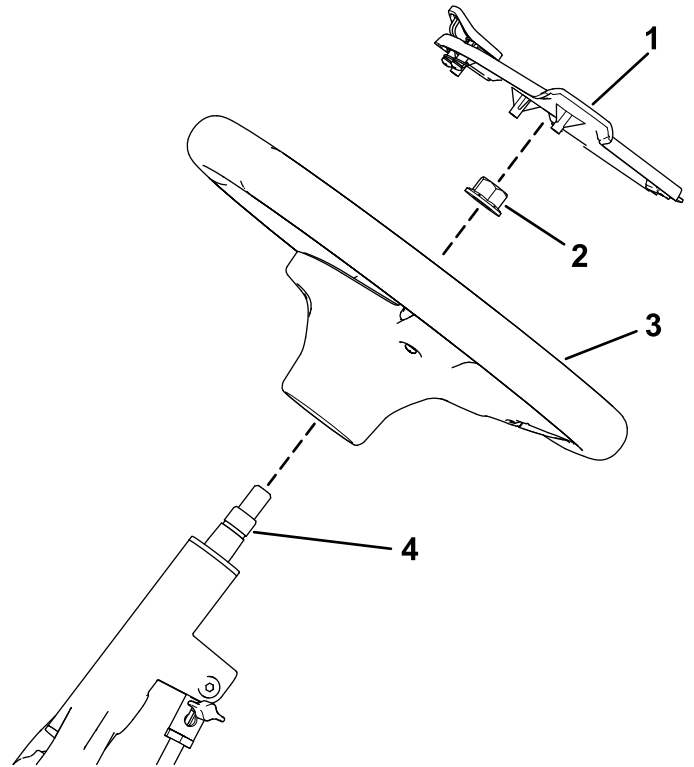

Figure 3

1. Cover
2. Locknut (1/2 inch)
3. Steering wheel
4. Steering shaft

g463560

2

Connecting the Battery

TC Models Only

No Parts Required

Procedure

⚠ WARNING

Incorrect battery cable routing could damage the machine and cables, causing sparks. Sparks can cause the battery gases to explode, resulting in personal injury.

- Always disconnect the negative (black) battery cable before disconnecting the positive (red) cable.
 - Always connect the positive (red) battery cable before connecting the negative (black) cable.
1. Connect the positive battery cable (red) to the positive (+) terminal of the battery and secure the cable using the bolt and nuts (Figure 4).
 2. Slide the insulator boot over the positive terminal (Figure 4).
Note: The insulator boot prevents a possible short-to-ground from occurring.
 3. Connect the negative battery cable (black) to the negative (-) terminal of the battery and secure the cable using the bolt and nuts (Figure 4).

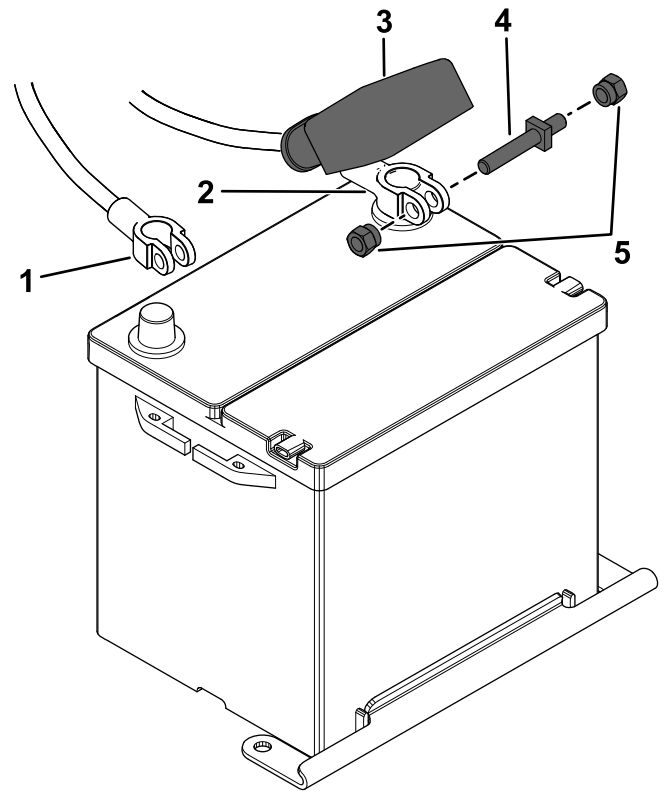

g464081

Figure 4

1. Negative battery cable (black)
2. Positive battery cable (red)
3. Insulator boot (positive battery cable)
4. Bolt
5. Nuts

3

Changing the Blinker Mode from United States (US) to European (EU)

International Models Only

No Parts Required

Procedure

Disconnect the default US jumper connection located underneath the hood (Figure 5).

Note: Use a cable tie to secure the loose connection.

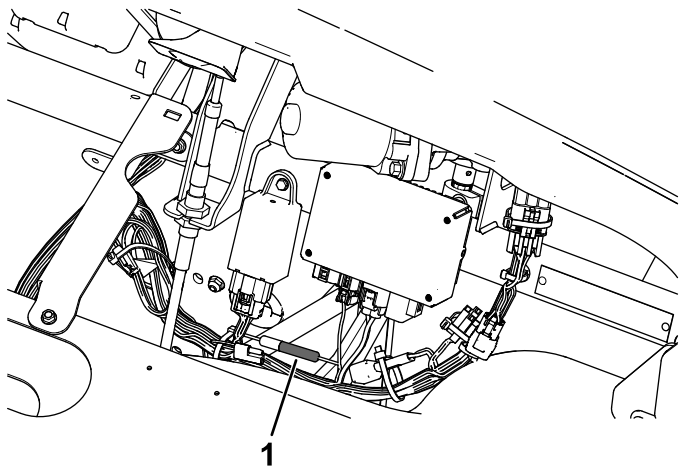

Figure 5

g400894

1. Default US jumper connection

4

Converting the Speedometer from mph to km/h

No Parts Required

Procedure

1. Shift the transmission lever to the P (PARK) position.
2. Rotate the key switch to the ON position.
3. Press and hold the display button between 3 to 10 seconds to convert the speedometer from mph to km/h.

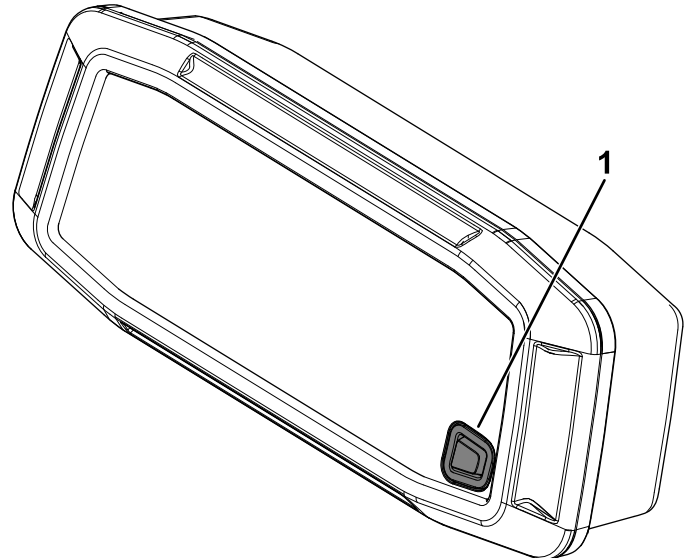

Figure 6

g367226

1. Button

5

Checking the Fluid Levels and Tire Pressure

No Parts Required

Procedure

1. Check the engine-oil level before you first start the engine; refer to [Checking the Engine-Oil Level \(page 61\)](#).
2. Check the transaxle-fluid level before you first start the engine; refer to [Checking the Transaxle-Fluid Level \(page 73\)](#).
3. Check the front differential oil level before you first start the engine; refer to [Checking the Front Differential Oil Level \(page 74\)](#).
4. Check the engine-coolant level before you first start the engine; refer to [5 Checking the Fluid Levels and Tire Pressure \(page 11\)](#).
5. Check the brake-fluid level before you first start the engine; refer to [Checking the Brake-Fluid Level \(page 78\)](#).
6. Check the air pressure in the tires; refer to [5 Checking the Fluid Levels and Tire Pressure \(page 11\)](#).

6

Installing the Rollover Protection System (ROPS)

TC Models Only

Parts needed for this procedure:

1	Left, front roll bar assembly
1	Right, front roll bar assembly
1	Left, rear roll bar assembly
1	Right, rear roll bar assembly
1	Front crosslink
1	Rear crosslink
1	Seat panel
2	Shoulder restraint
8	Hex-head bolt (3/8 x 1-1/4 inches)
12	Carriage bolt (5/16 x 3/4 inch)
4	Hex-washer head bolt (5/16 x 3/4 inch)
10	Hex-washer head bolt (1/4 x 3/4 inch)
2	Hex-washer head bolt (1/4 x 1 inch)
2	Button-head bolt (5/16 x 1-1/2 inches)
2	Flange-head bolt (3/8 x 2-1/4 inches)
14	Locknut (5/16 inch)
10	Locknut (3/8 inch)
2	Locknut (1/4 inch)
2	Locknut (7/16 inch)
1	CVT-intake hood

Procedure

1. Raise the cargo bed (Figure 7).

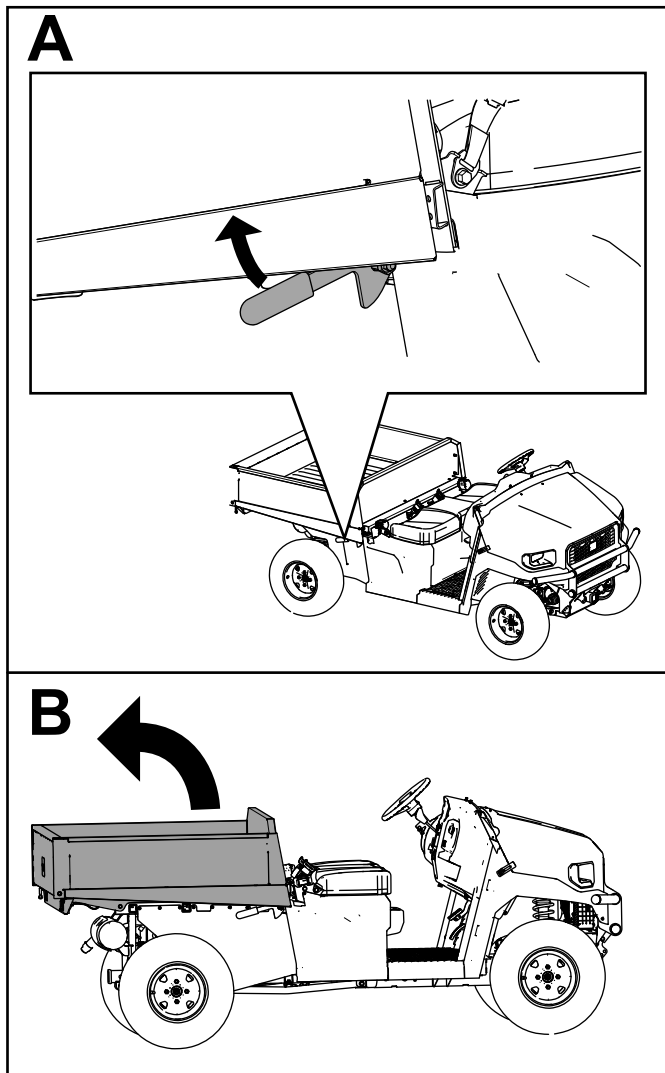

Figure 7

g361797

2. Raise the hood (Figure 8).

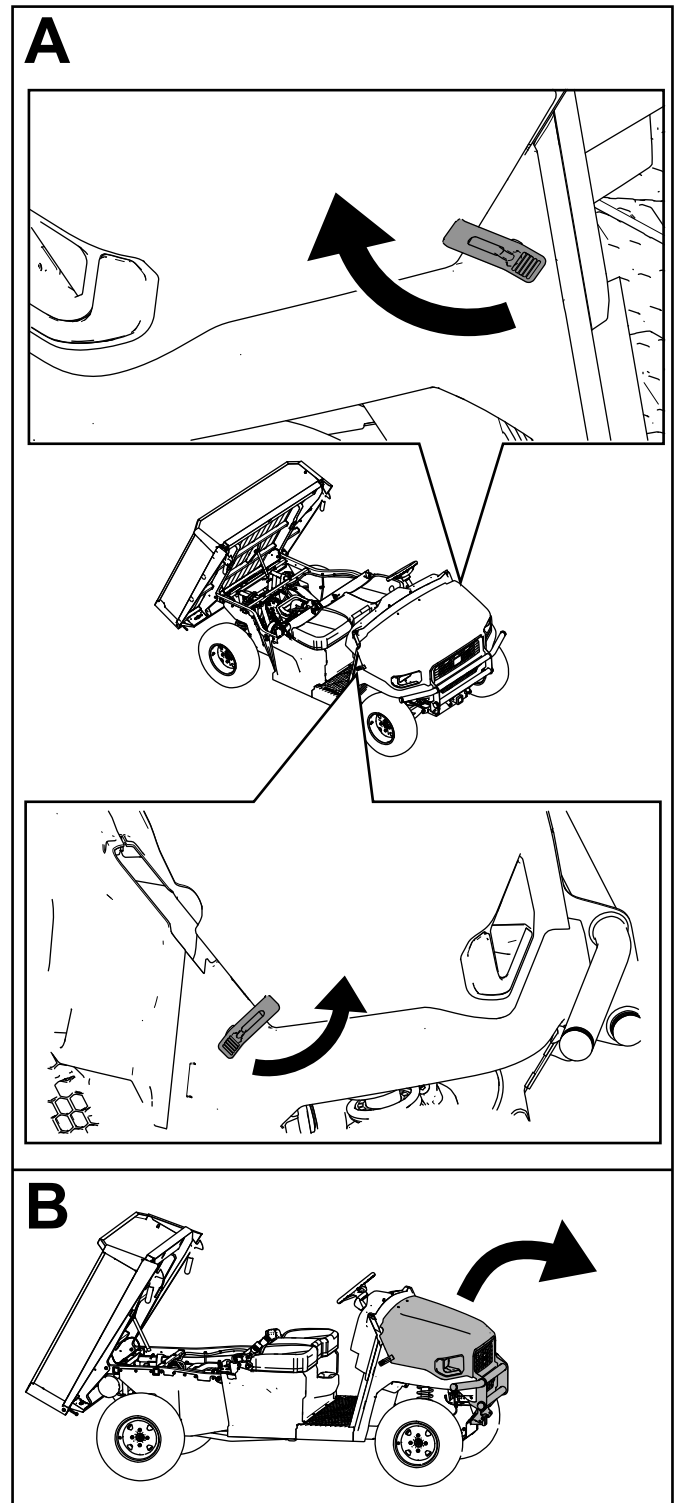

Figure 8

g361798

3. Remove the hex-washer head bolts (1/4 x 3/4 inch) and T30 torx-head fasteners from the right and left seat-base panels (Figure 9).

Remove the fuel-tank cap from the left seat-base panel (Figure 10).

Note: Do not pull the cap out until you reach the end of the tether.

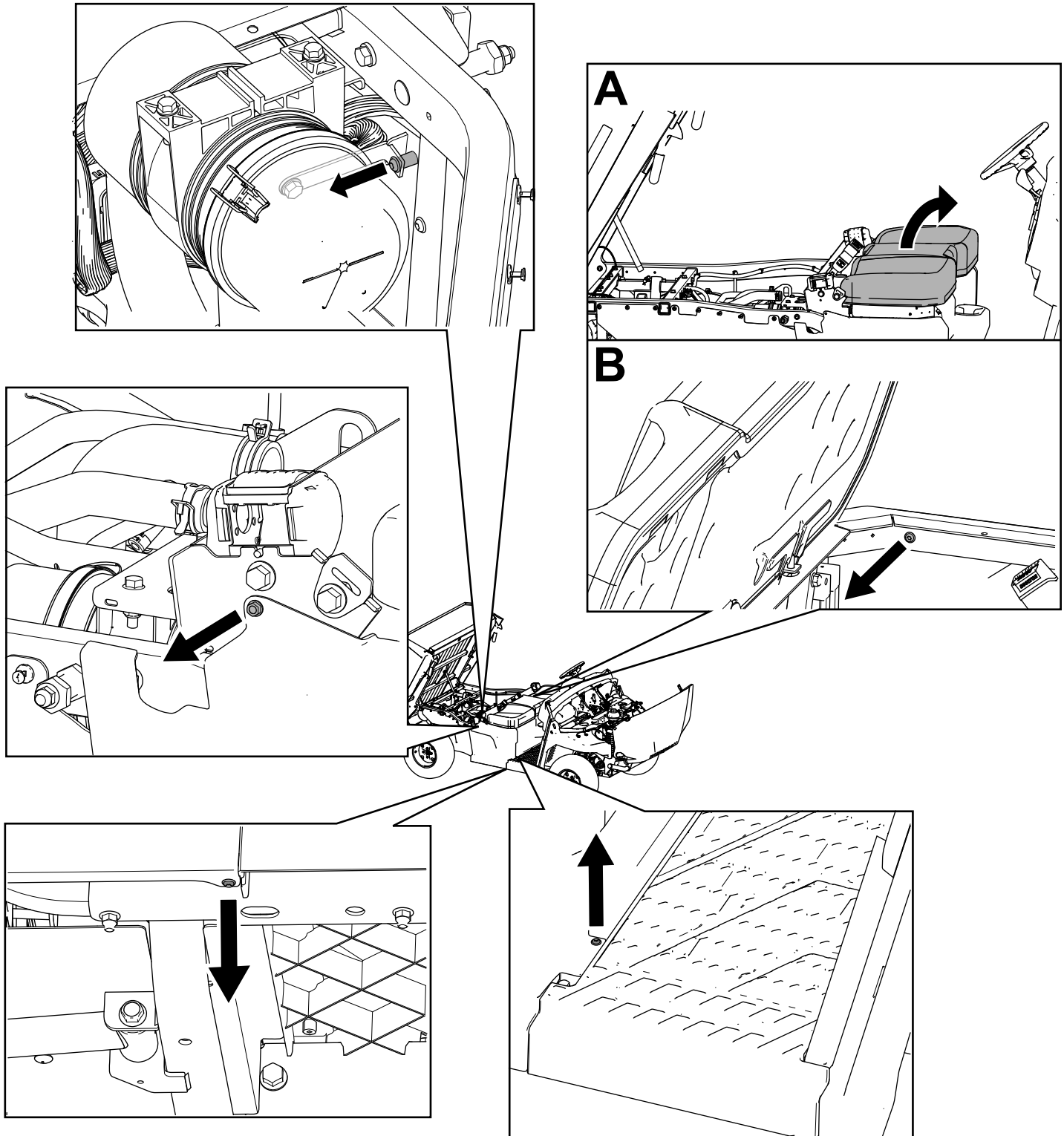

Figure 9

g361802

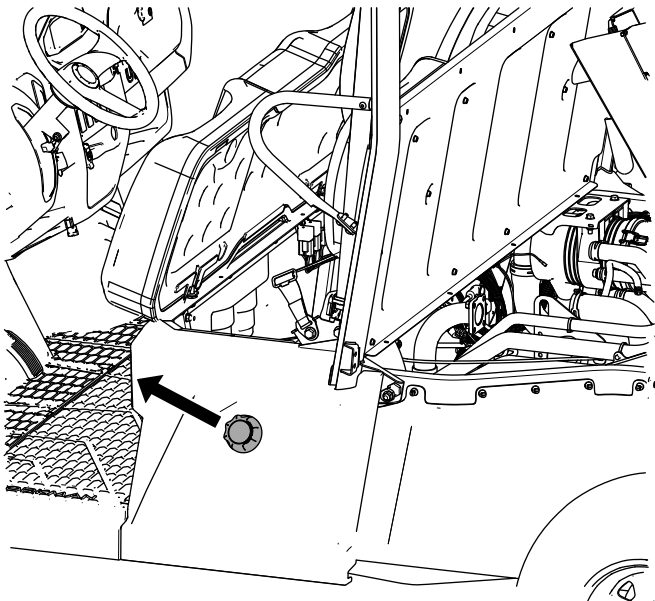

Figure 10

g364231

4. Remove the locknut (3/8 inch) and latch pin from the right and left, rear frame tubes (Figure 11).

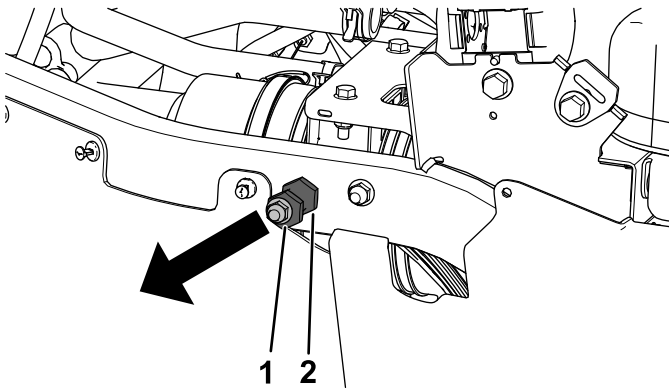

Figure 11

g361803

1. Locknut (3/8 inch) 2. Latch pin

5. Loosely secure the right, rear roll bar assembly to the right, rear frame tube using 1 flange-head bolt (3/8 x 2-1/4 inches) and 1 locknut (3/8 inch) as shown in Figure 12.

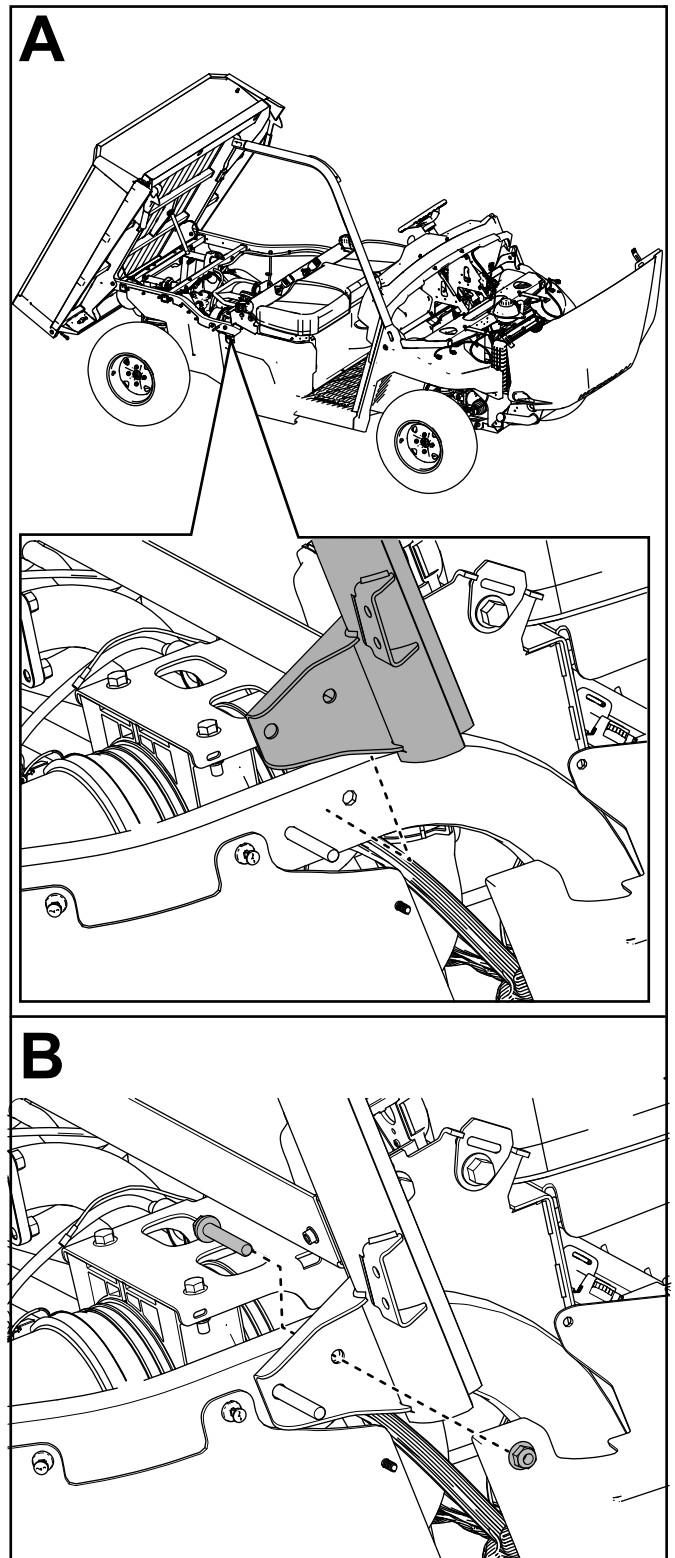

Figure 12

g361804

6. Repeat steps 3 through 5 for the left, rear roll bar assembly.
7. Loosely secure the right, front roll bar assembly to the right roll bar mount bracket using 2 hex-head bolts (3/8 x 1-1/4 inches) and 2 locknuts (3/8 inch) as shown in Figure 13.

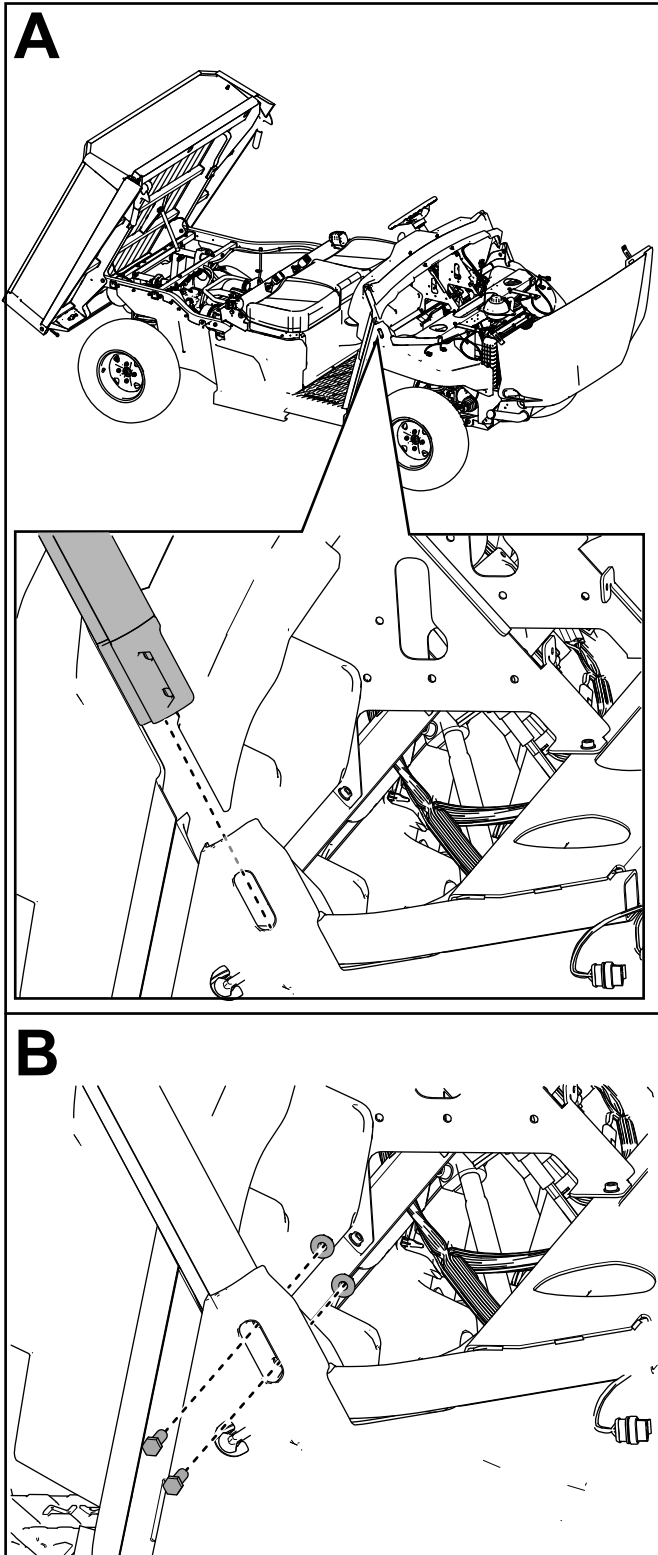

Figure 13

g361799

8. Loosely secure the right, front roll bar assembly to the right, rear roll bar assembly using 2 hex-head bolts (3/8 x 1-1/4 inches) and 2 locknuts (3/8 inch) as shown in Figure 14.

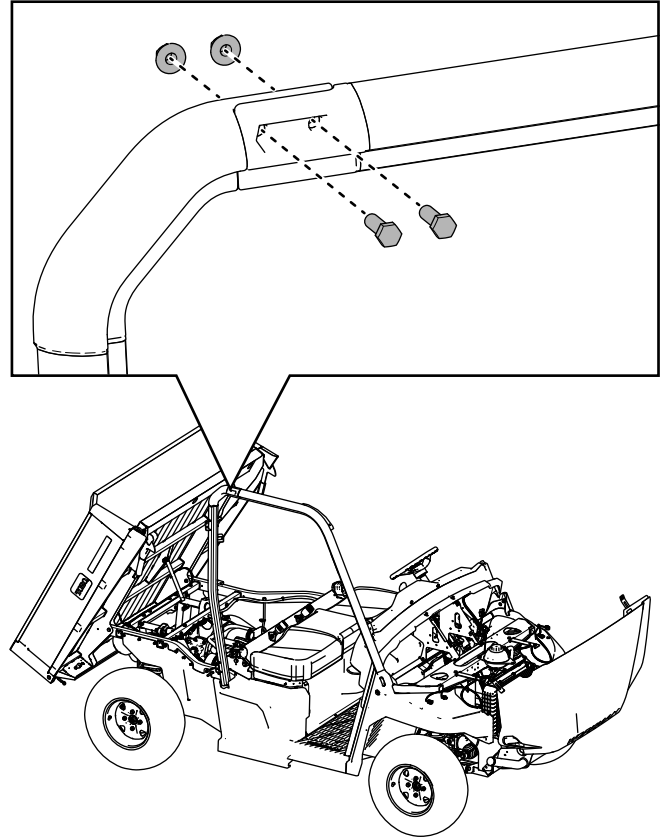

Figure 14

g361800

9. Loosely secure the right, front roll bar assembly to the dash panel using 1 hex-washer head bolt (1/4 x 1 inch) and 1 locknut (1/4 inch) as shown in Figure 15.

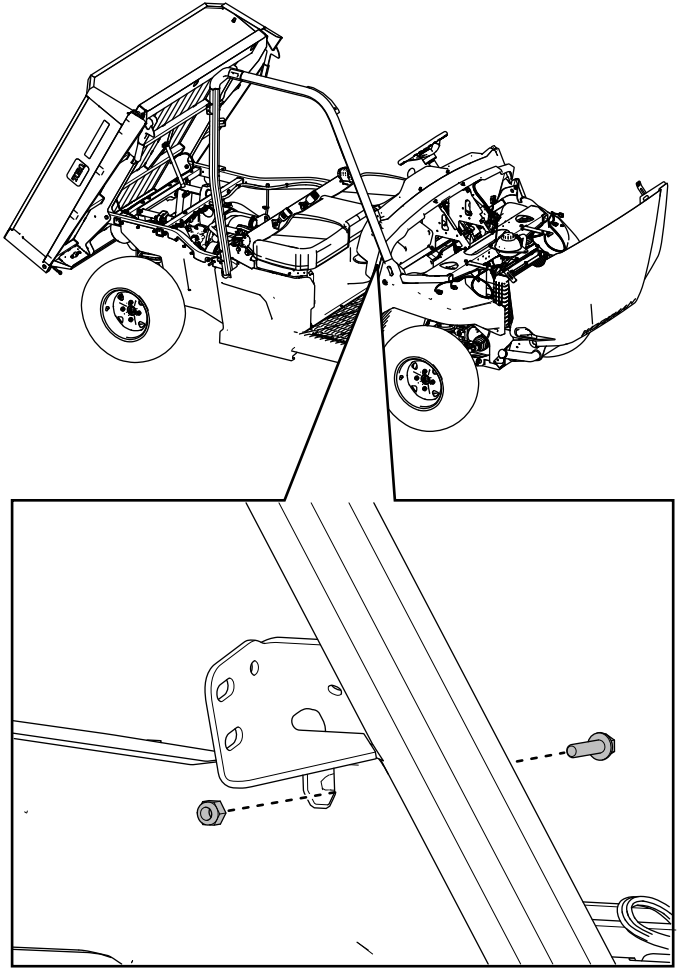

Figure 15

g361801

10. Repeat steps 7 through 9 for the left, front roll bar assembly.

11. Secure the front crosslink to the front roll bar assemblies using 4 carriage bolts (5/16 x 3/4 inch) and 4 locknuts (5/16 inch) as shown in Figure 16.

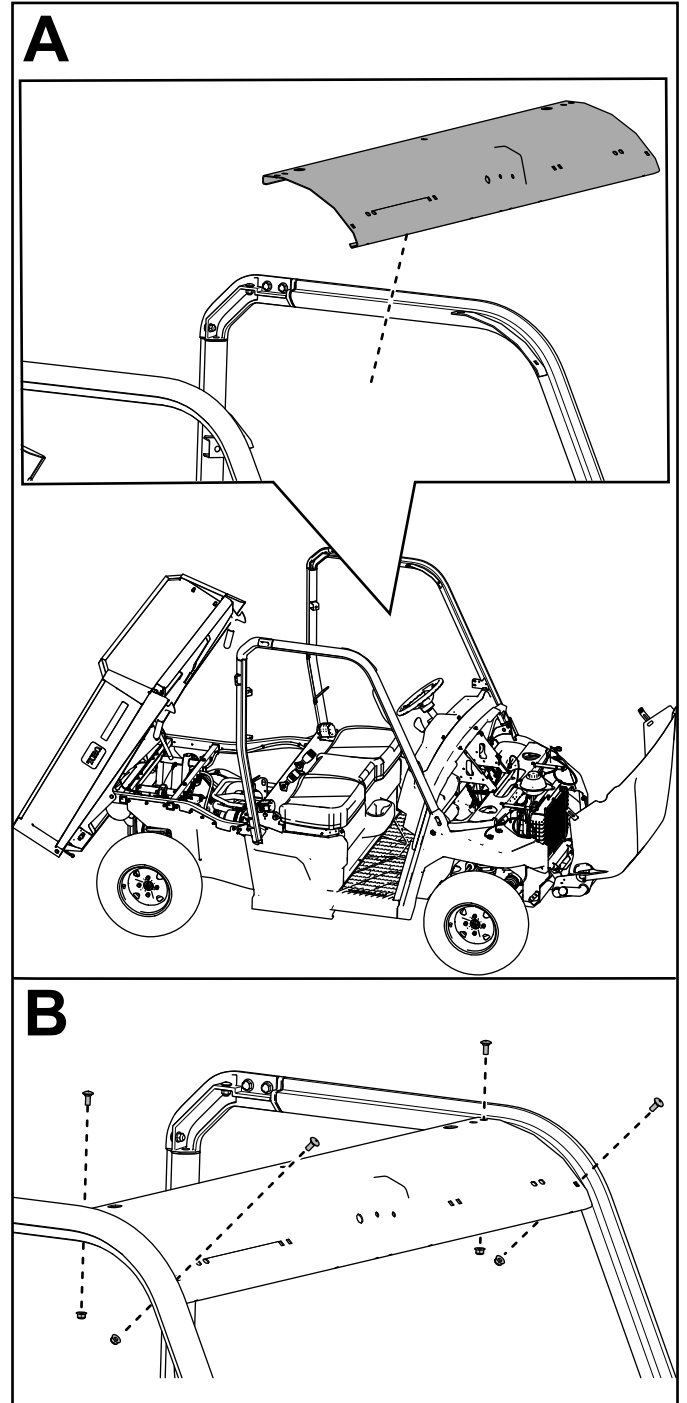

Figure 16

g361807

12. Secure the rear crosslink to the rear roll bar assemblies using 4 carriage bolts (5/16 x 3/4 inch) and 4 locknuts (5/16 inch) as shown in Figure 17.
- Ensure that you position the crosslink as shown in Figure 17.

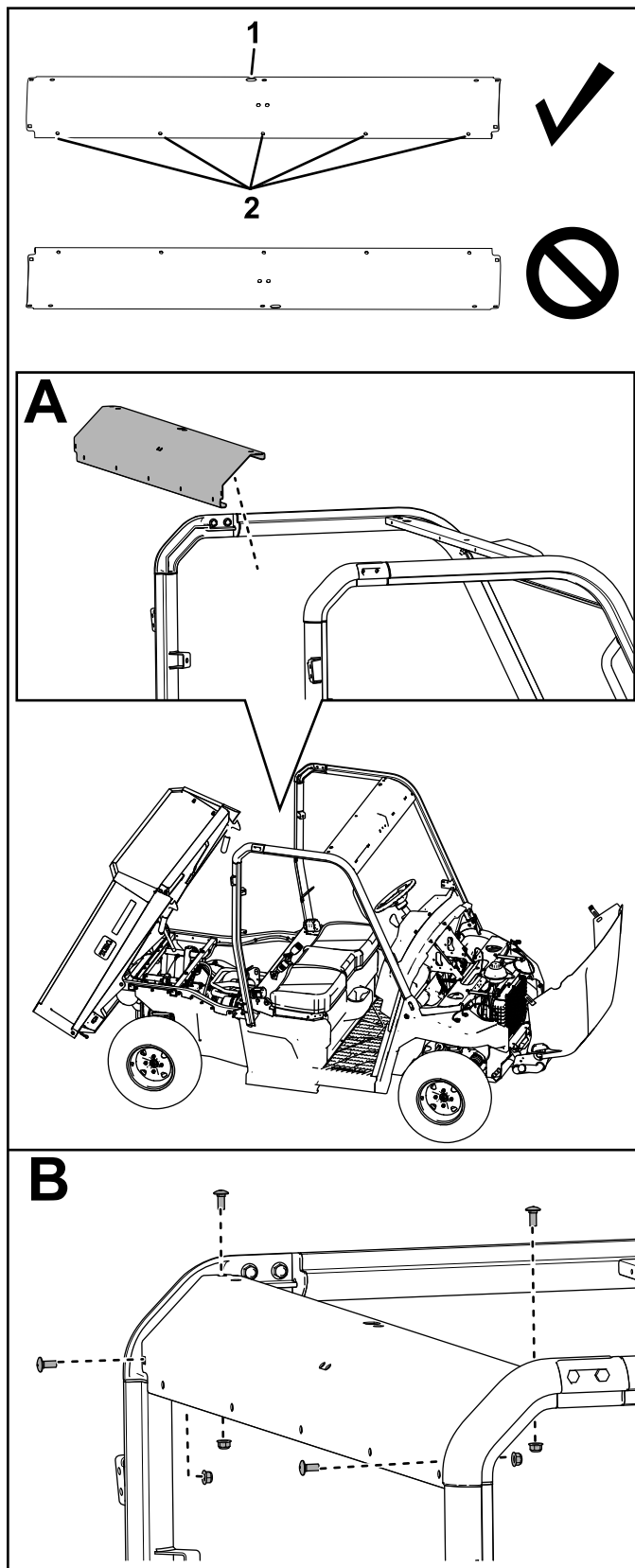

Figure 17

g361808

1. Ensure that the notch is on the top.
2. Ensure that the holes are on the bottom.

13. Secure the seat panel to the rear roll bar assemblies using 4 carriage bolts (5/16 x 3/4

inch) and 4 locknuts (5/16 inch) as shown in Figure 18.

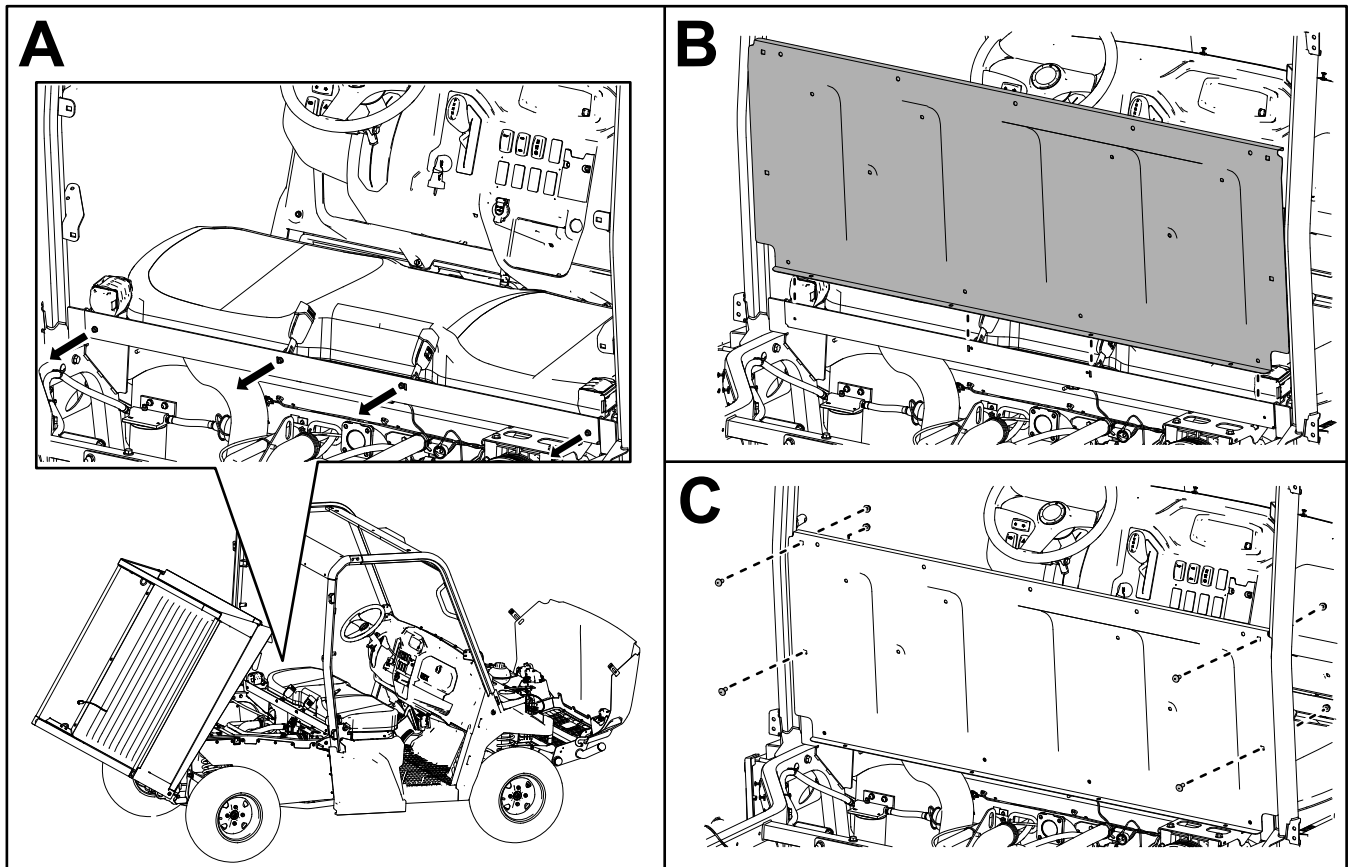
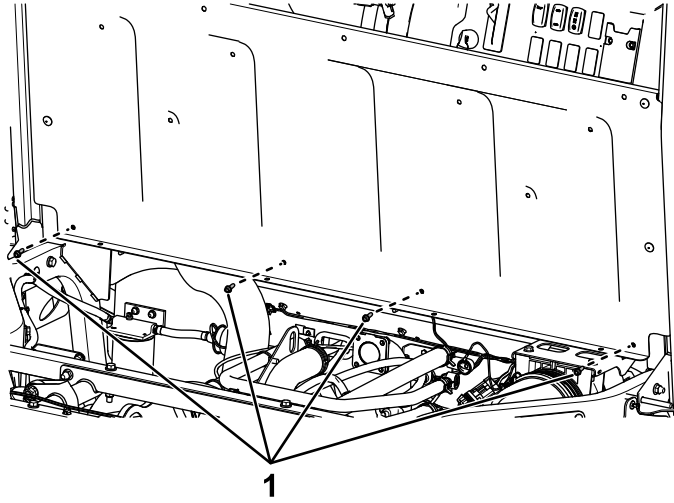

Figure 18

g362076

- Secure the seat panel to the rear frame crosslink channel using 4 hex-washer head bolts (1/4 x 3/4 inch) as shown in [Figure 19](#).



g361809

Figure 19

- Hex-washer head bolts (1/4 x 3/4 inch)
-

15. Torque the fasteners to the specifications shown in [Figure 20](#).

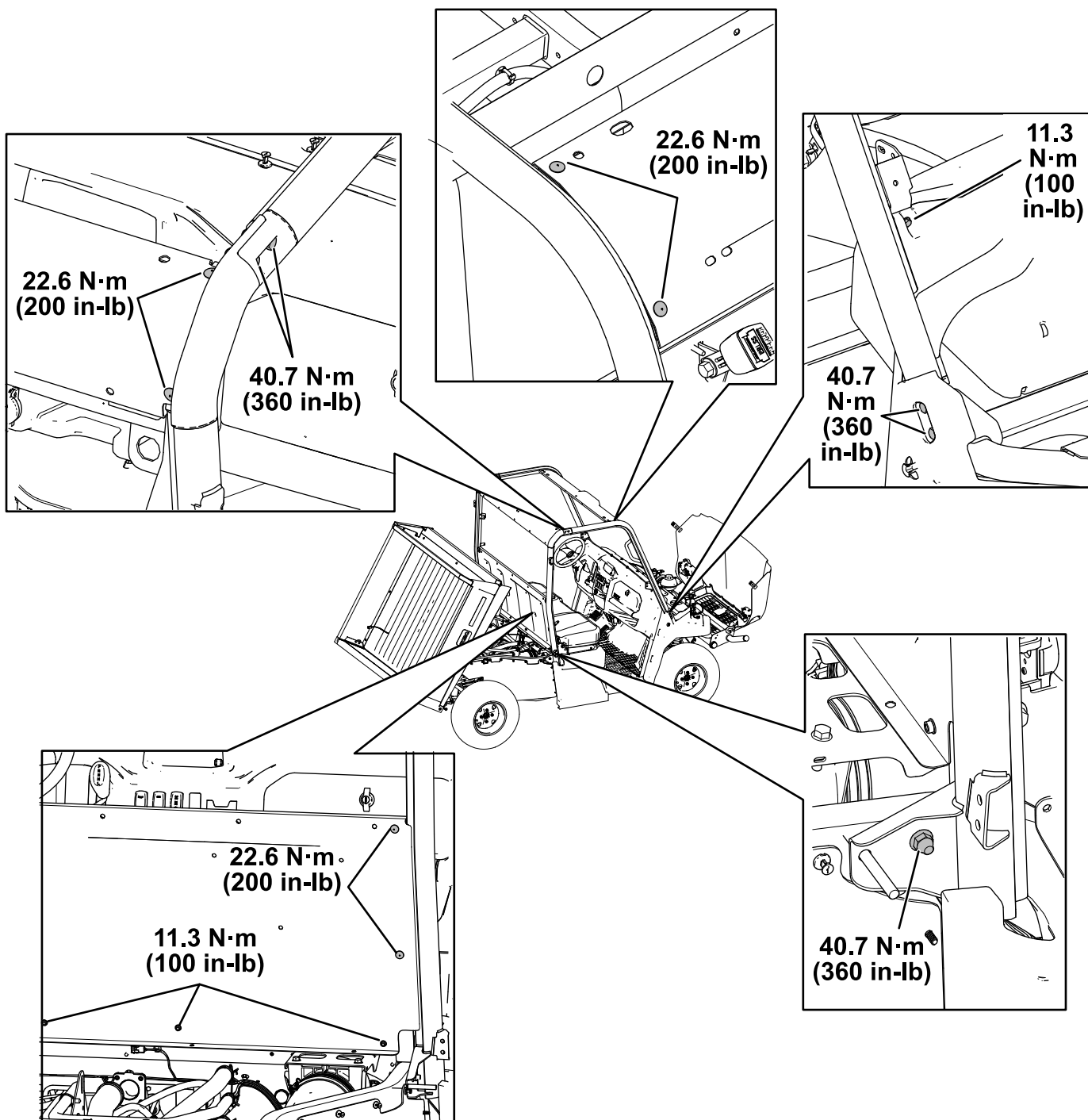

Figure 20

g362077

16. Secure the 2 shoulder restraints to the rear roll bar assemblies using 4 self-tapping screws (5/16 x 3/4 inch), 2 button-head bolts (5/16 x 1-1/2 inches), 2 button-head bolts (5/16 x 1-1/2 inches), and 2 locknuts (5/16 inch) as shown in [Figure 21](#).

Torque the locknuts (5/16 inch) to 22.6 N·m (200 in-lb) as shown in [Figure 21](#).

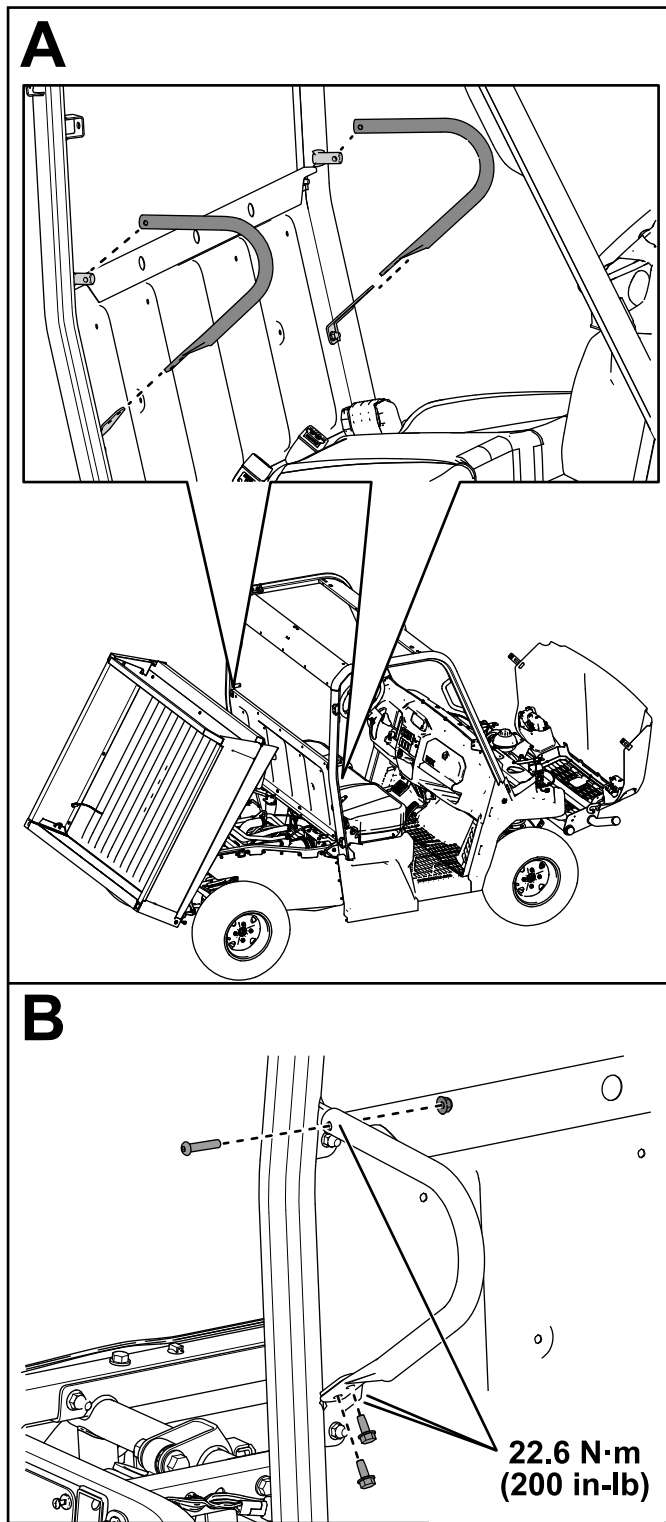

Figure 21

g417719

17. Secure the right seat belt as follows:
- A. Remove the cap from the top portion of the seat belt (Figure 22).
 - B. Insert seat belt into the roll bar seat belt bracket and secure the seat belt using a locknut (7/16 inch) as shown in Figure 22.
Torque the locknut (7/16 inch) to 48.8 N·m (432 in-lb) as shown in Figure 22.
 - C. Install the cap (Figure 22).
 - D. Repeat these steps for the left seat belt.

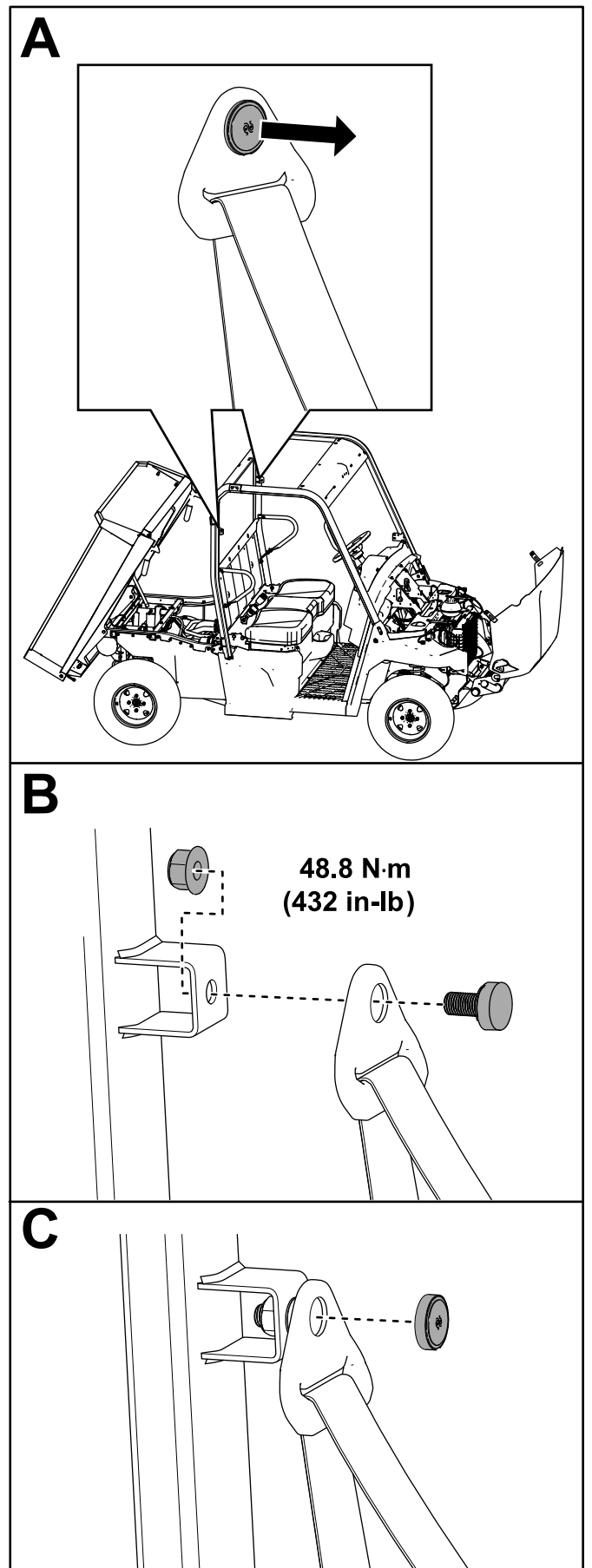

Figure 22

g361796

18. To install the CVT-intake hood and the seat backs, do the following:
- A. Remove the 2 flange-head bolts (1/4 x 3/8 inch) from the CVT-intake hood (Figure 23).
Retain the bolts.

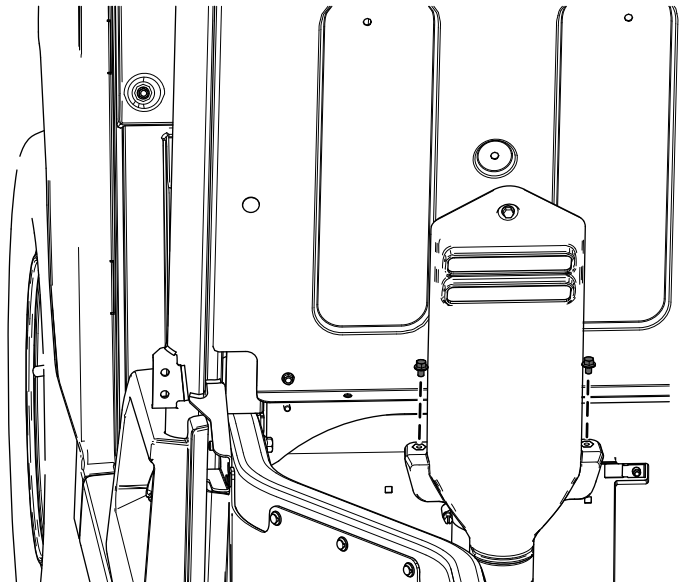

Figure 23

g464082

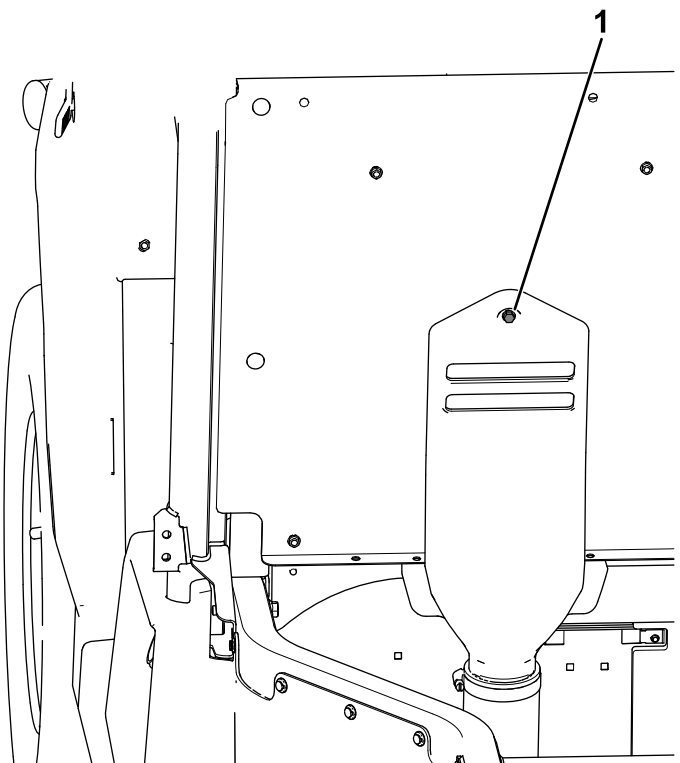

Figure 24

g463425

1. Captive bolt

- B. Insert the captive bolt attached to the CVT-intake hood into the hole shown in the seat panel (Figure 24).

Do not secure the bolt at this time.

If your machine **does not have** the holes present in the seat panel for the CVT-intake hood, proceed to **step C**.

If your machine **does have** the holes present in the seat panel for the CVT-intake hood, proceed to **step E**.

- C. Using the CVT-intake hood as the template, mark the 2 hole locations (Figure 25).

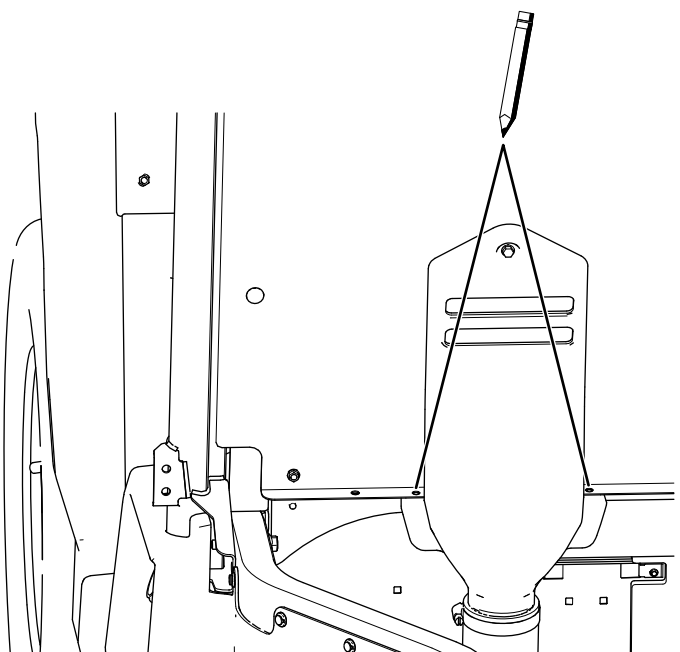

Figure 25

g463428

- D. Move the CVT-intake hood and drill the 2 holes (11/32 inch) into the seat panel (Figure 26).

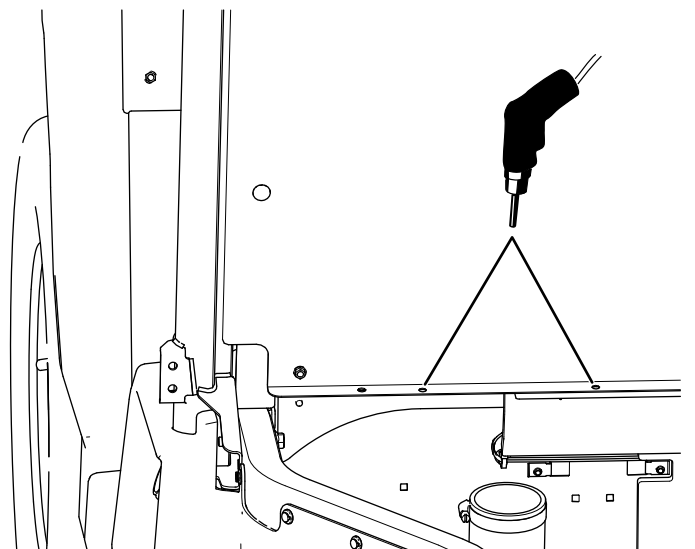

Figure 26

g463424

⚠ CAUTION

Using a drill without proper eye protection may allow debris to enter the eyes, causing injury.

When drilling, always wear eye protection.

- E. Secure the 2 seat backs to the seat panel using 5 hex-washer head bolts (1/4 x 3/4 inch) as shown in Figure 27.

Do not install a bolt into the left, middle hole in the seat panel.

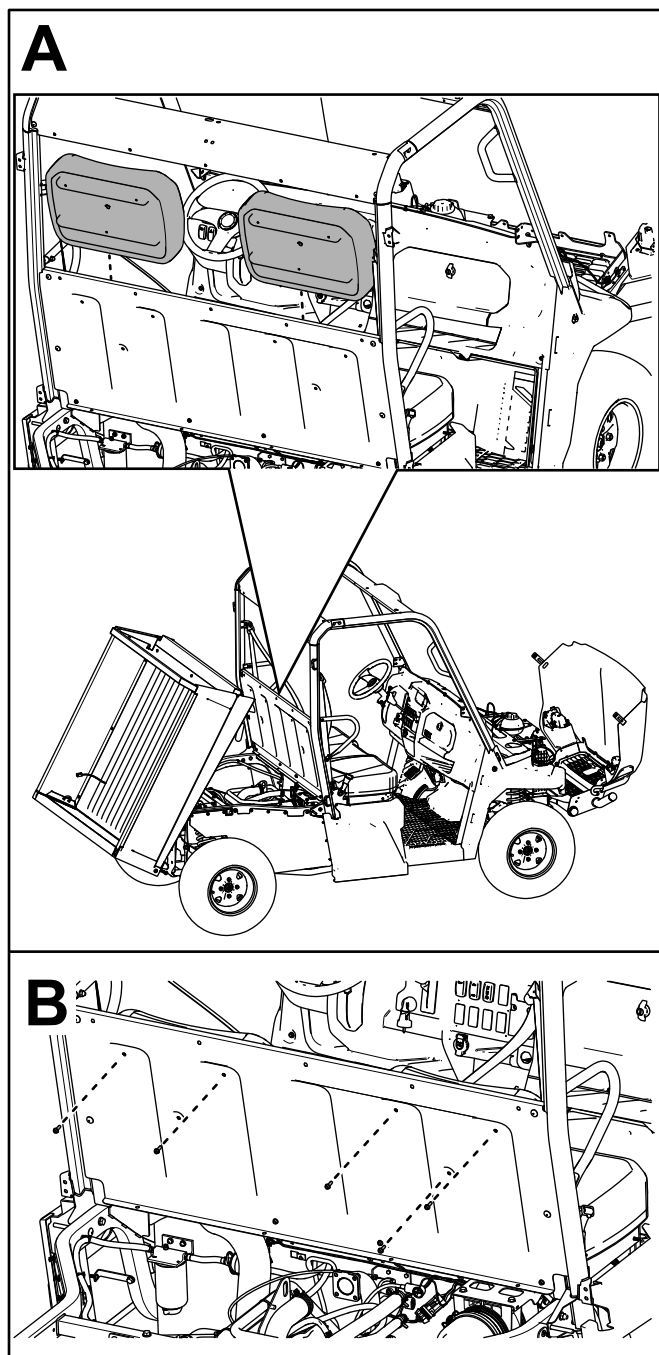

Figure 27

g463427

- F. Insert the captive bolt attached to the CVT-intake hood into the hole shown on the seat panel (Figure 28).

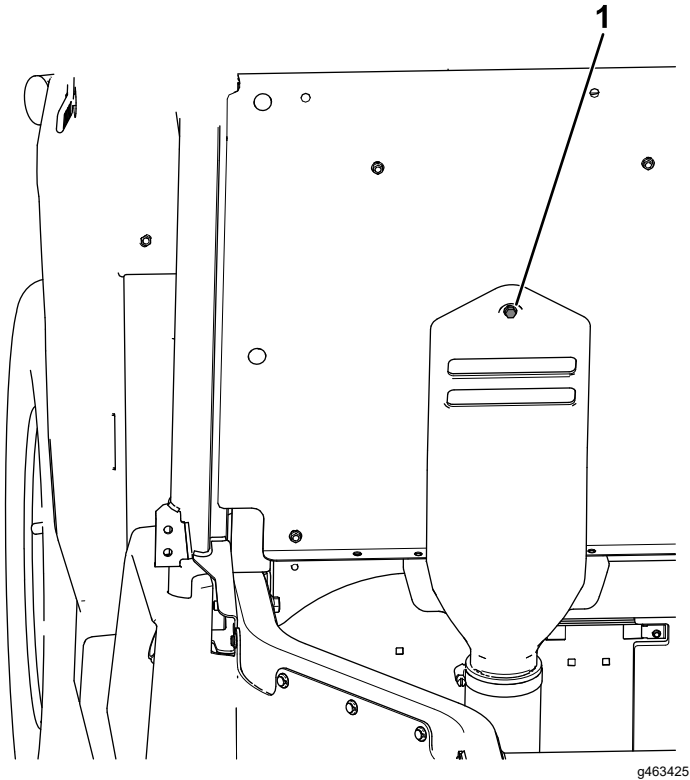

Figure 28

- H. Torque the 5 hex-washer head bolts (1/4 x 3/4 inch) and the captive bolt attached to the CVT-intake hood to 5.4 N·m (48 in-lb) as shown in Figure 30.

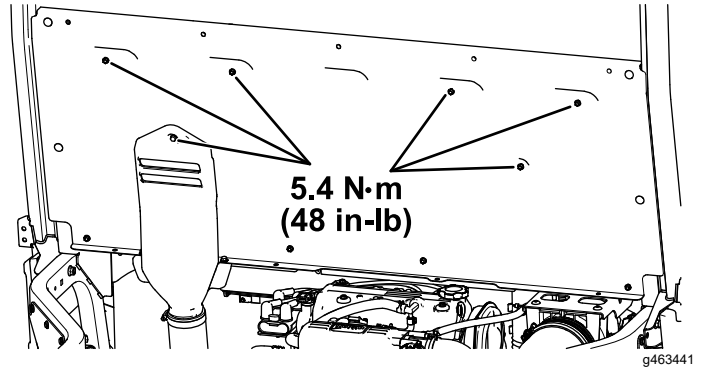

Figure 30

g463441

- G. Secure the bottom of the CVT-intake hood to the seat panel using the previously-removed 2 flange-head bolts (1/4 x 3/8 inch) as shown in Figure 29.

Torque the 2 flange-head bolts (1/4 x 3/8 inch) to 5.4 N·m (48 in-lb).

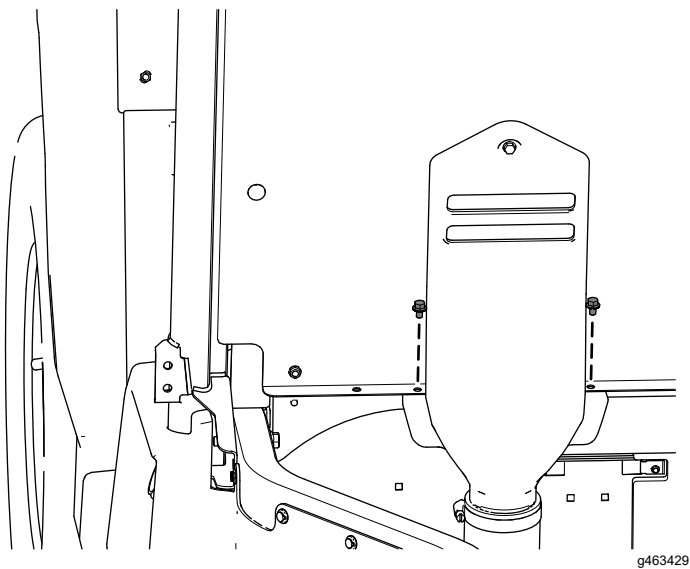

Figure 29

g463429

19. Install the previously removed locknuts (3/8 inch) and latch pins to the right and left, rear frame tubes (Figure 31).

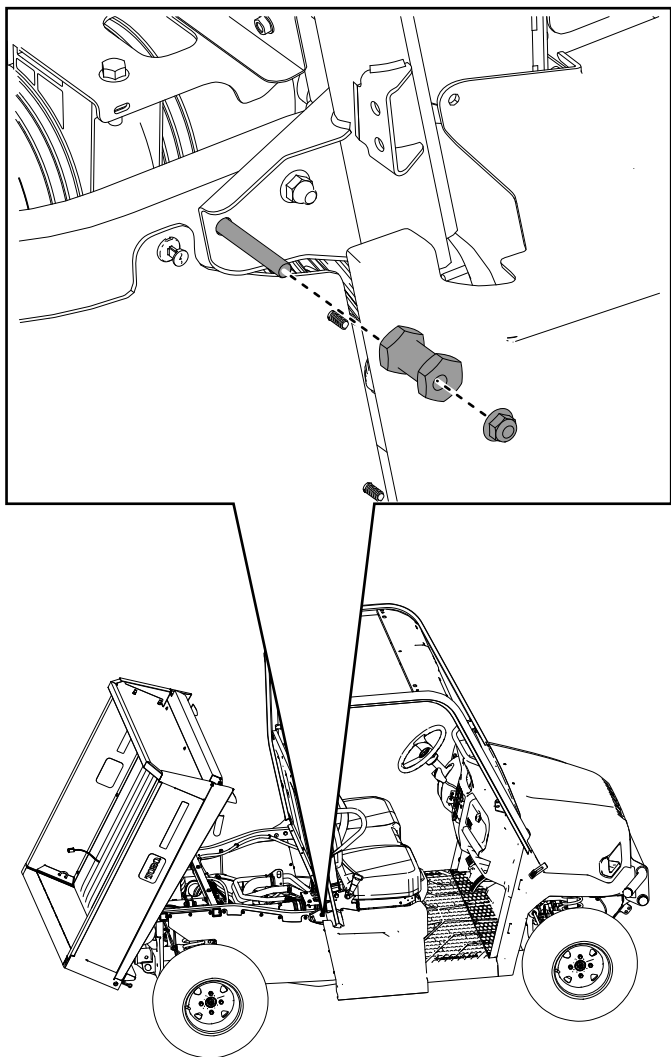

Figure 31

g361795

20. Adjust the alignment nut for the cargo bed latch until you close the gap and the cargo bed latches securely (Figure 32).

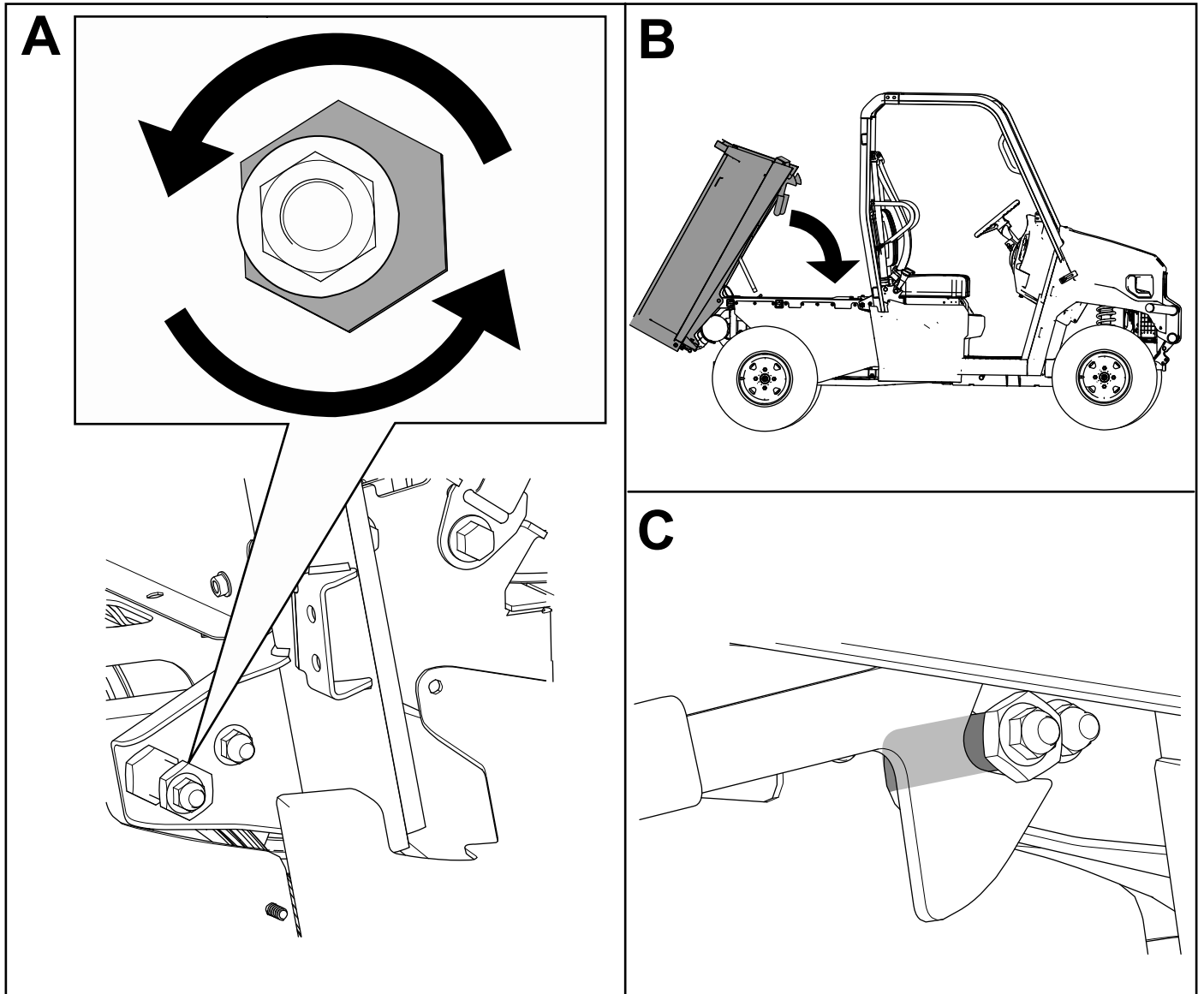

Figure 32

g361794

21. Torque the locknut (3/8 inch) to 40.7 N·m (360 in-lb) as shown in [Figure 33](#).

22. Secure the right and left seat-base panels using the previously removed hex-washer head bolts (1/4 x 3/4 inch) as shown in [Figure 34](#).

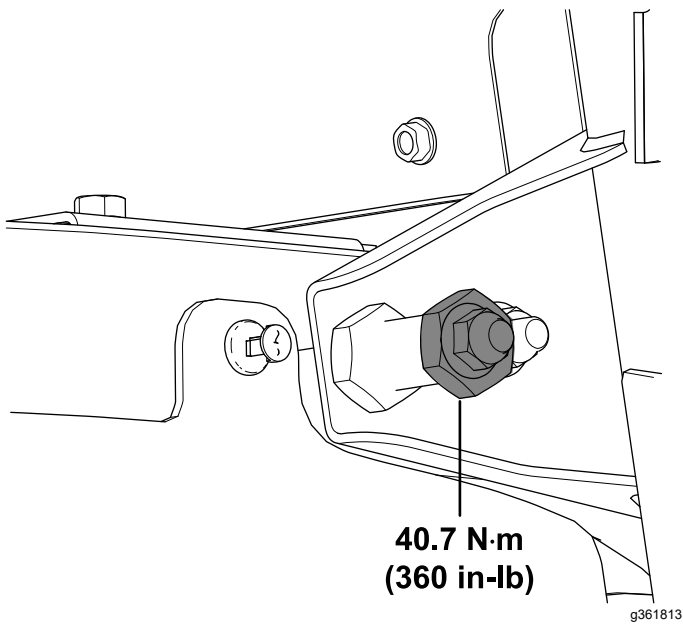

Figure 33

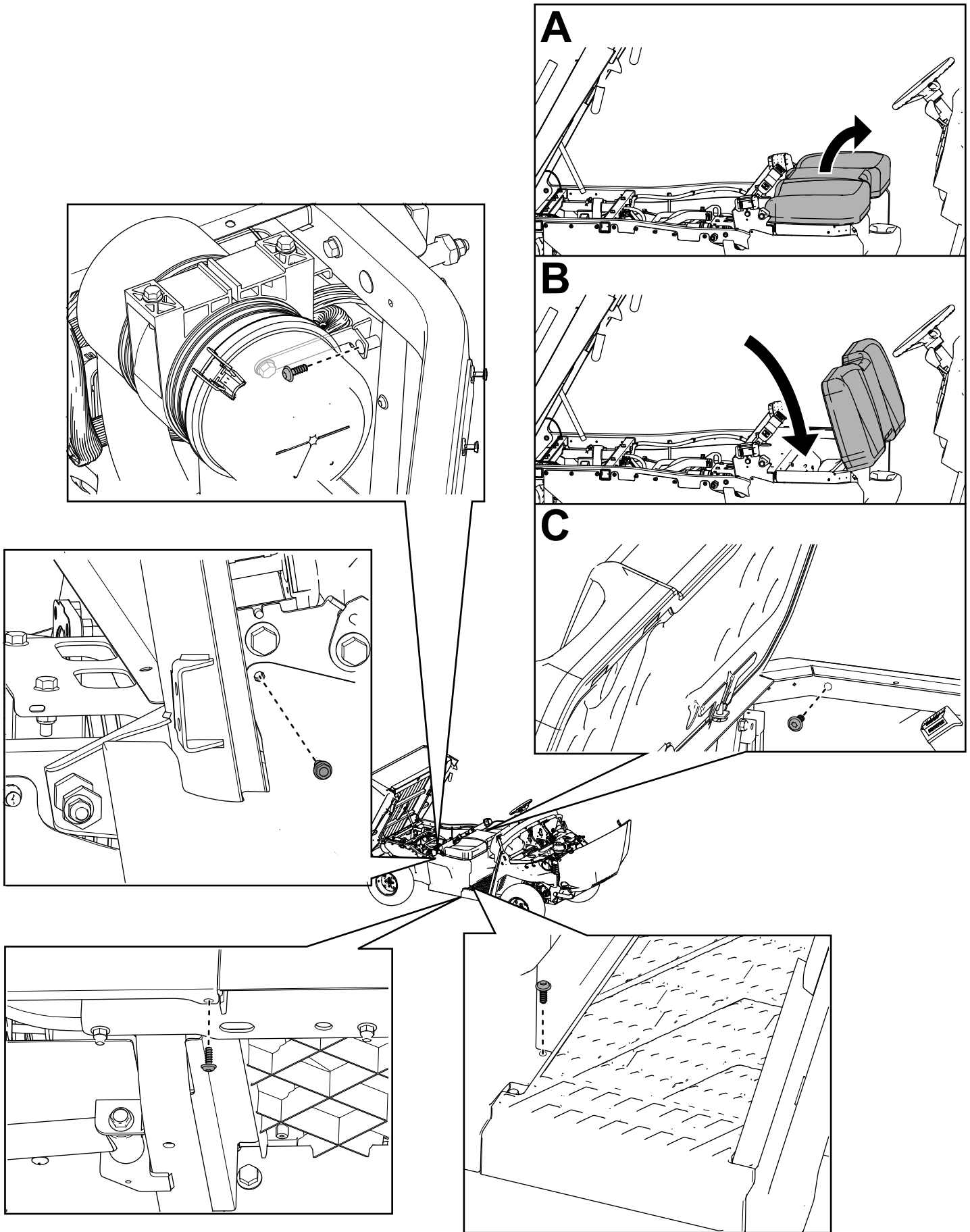

Figure 34

g361811

23. Install the fuel-tank cap to the left seat-base panel (Figure 35).

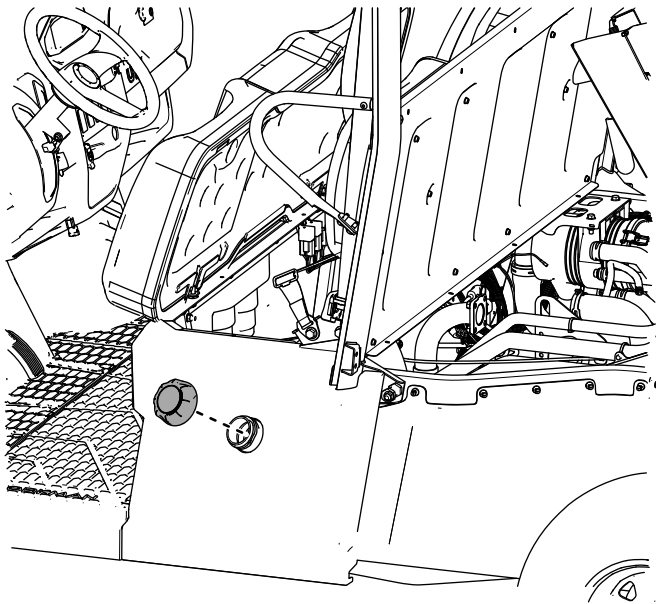

Figure 35

g364835

7

Burnishing the Brakes

No Parts Required

Procedure

To ensure optimum performance of the brake system, burnish the brakes before use.

1. Bring the machine up to full speed, apply the brakes to rapidly stop the machine without locking up the tires.
2. Repeat this procedure 10 times, waiting 1 minute between stops, to avoid overheating the brakes.

Product Overview

Controls

Become familiar with all the controls before you start the engine and operate the machine.

Control Panel

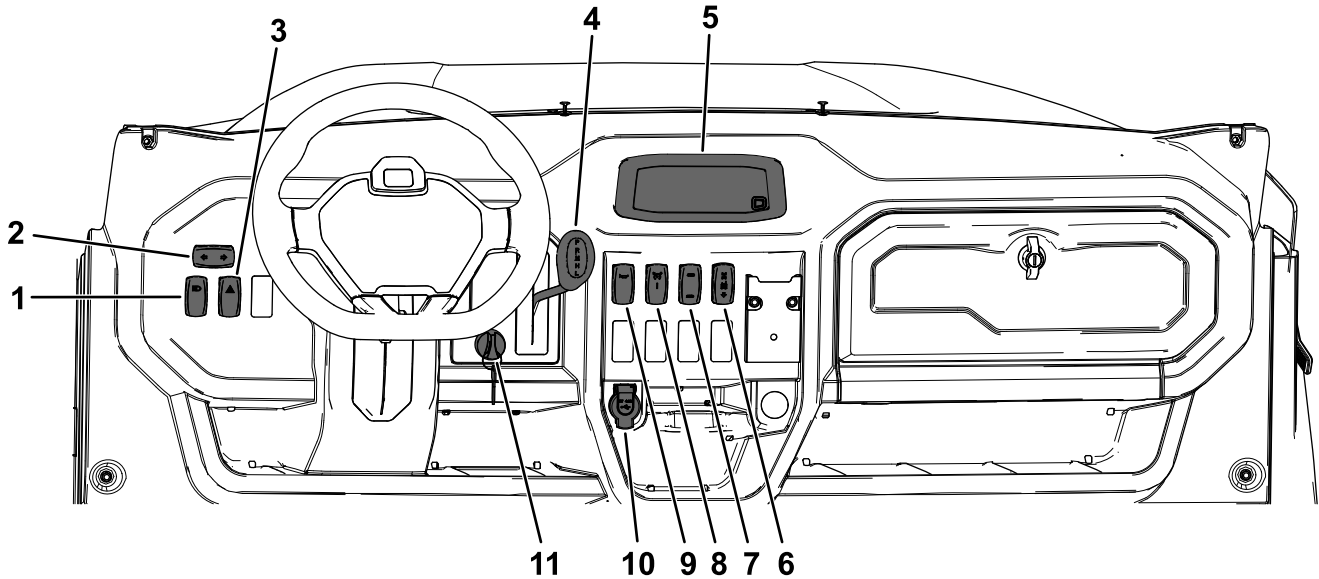

Figure 36

g463676

- | | | | |
|------------------------|-----------------------------|---------------------------------------|----------------------------|
| 1. Headlight switch | 4. Gear selector | 7. 2-wheel drive/4-wheel drive switch | 10. USB power point switch |
| 2. Turn-signal switch | 5. Display | 8. Cruise control switch | 11. Key switch |
| 3. Hazard-light switch | 6. Differential-lock switch | 9. Horn switch | |

Key Switch

Use the key switch to start and shut off the engine.

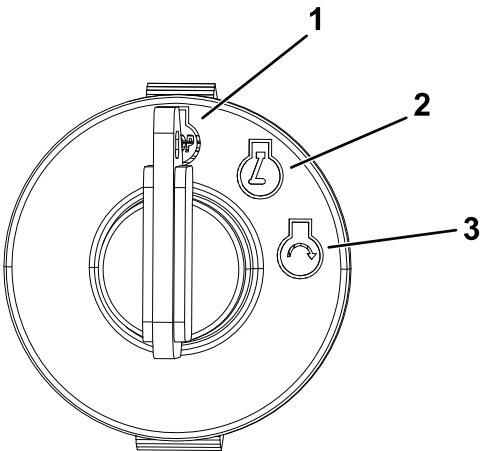

Figure 37

g375755

- | | |
|----------------|-----------------|
| 1. Stop engine | 3. Start engine |
| 2. Run engine | |

Headlight Switch

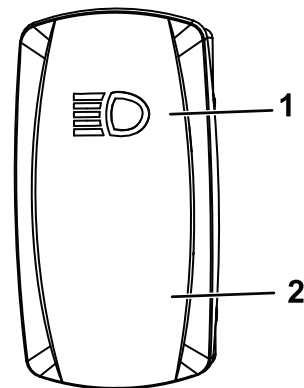

Figure 38

g598300

- | | |
|-------|--------|
| 1. On | 2. Off |
|-------|--------|

Turn-Signal Switch

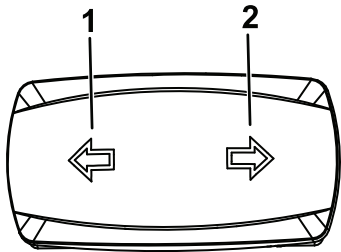

Figure 39

g598293

1. Left 2. Right

Hazard-Light Switch

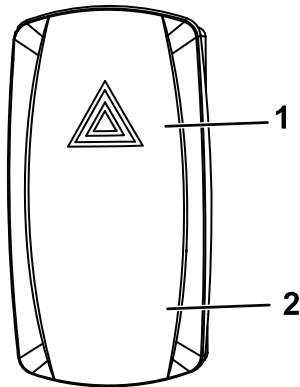

Figure 40

g598296

1. On 2. Off

Cruise Control Switch

Press the cruise control switch up to set the desired drive speed.

In order to use cruise control, your seat belt must be fastened, and you need to be driving at the following ground speed based on your selected gear:

- **H (High Forward) gear**—6 km/h (4 mph) or greater
- **L (Low Forward) gear**—3 km/h (2 mph) or greater

Press the button 1 time to increase the ground speed by an increment of 1 km/h (1 mph).

Note: When you press the brake pedal, the cruise control disengages.

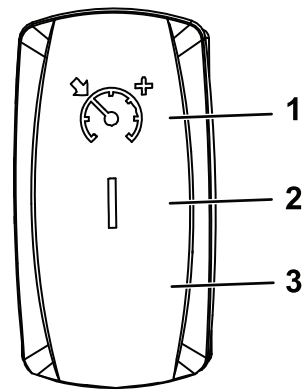

Figure 41

g598294

1. Set/Increase cruise control 3. Off
2. On

Differential-Lock Switch

Use the differential-lock switch to engage or disengage the front and/or rear differentials; refer to [Using the 4-Wheel Drive/Differential Lock\(s\)](#) (page 47).

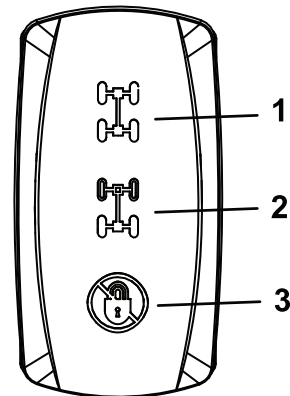

Figure 42

g598295

1. Engage the front and rear differential locks 3. Disengage the differential lock(s)
2. Engage the rear differential lock

2-Wheel Drive/4-Wheel Drive Switch

Use the 2-wheel drive/4-wheel drive switch to toggle between 2-wheel drive and 4-wheel drive; refer to [Using the 4-Wheel Drive/Differential Lock\(s\)](#) (page 47)

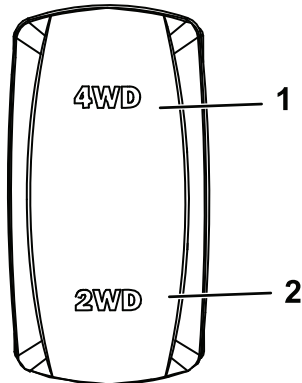

Figure 43

g598292

-
1. 4-wheel drive 2. 2-wheel drive

Horn Switch

Press the horn switch to sound the horn.

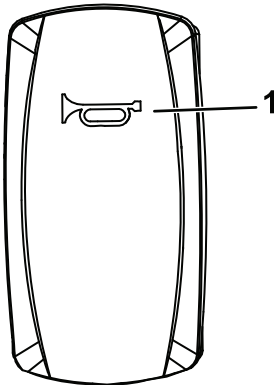

Figure 44

g598297

-
1. On

USB Power Point

Use the power point to power mobile devices.

Gear Selector

Use the gear selector to shift the transmission between **P** (PARK), **R** (REVERSE), **N** (NEUTRAL), **H** (HIGH FORWARD), and **L** (LOW FORWARD) ground operation.

Important: Do not shift the transmission to the REVERSE, HIGH, or LOW gear unless the machine is motionless and the engine is at low-idle; otherwise, you could damage the transmission.

Display

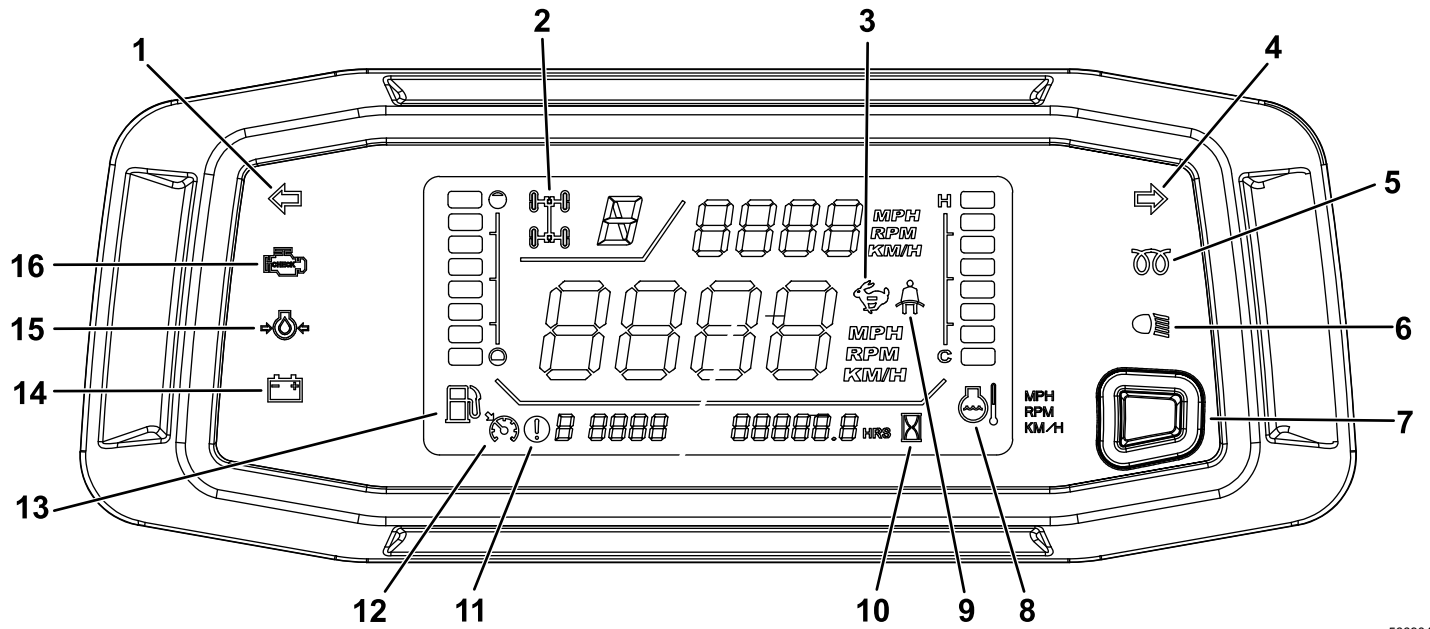

g566904

Figure 45





- | | |
|--|--------------------------------|
| 1. Left-turn signal indicator | 9. Seat belt indicator |
| 2. 2-wheel drive/4-wheel drive/differential lock indicator | 10. Hour meter/Odometer |
| 3. Cruise control/speed-limited indicator | 11. Fault code indicator |
| 4. Right-turn signal indicator | 12. Cruise control |
| 5. Glow-plug indicator (diesel machines only) | 13. Fuel gauge |
| 6. Headlights indicator | 14. Charge indicator |
| 7. Display button/ground speed governor control | 15. Oil-pressure warning light |
| 8. Coolant-temperature gauge and indicator | 16. Check-engine light |

Turn-Signal Indicators

The left or right turn-signal blinks when you press the turn-signal switch to the left or right.

2-Wheel Drive/4-Wheel Drive/Differential Lock Indicator

Note: When the indicator is blinking it means that the setting is not engaged/inactive; when it becomes solid, it is engaged/active.

2-Wheel Drive/4-Wheel Drive Switch Position	Differential Lock Switch Position	Result
2	5	No indicator
2	4	
2	3	 (blinking—inactive configuration)
1	5	
1	4	
1	3	

Cruise Control/Speed-Limited Indicator

If the cruise control is set, the indicator illuminates.

If the top speed of the machine is limited, the indicator illuminates. The speed is limited if the following occurs:

- The cruise control is set.
- There is a fault code.
- A seat belt is not buckled.

Glow-Plug Indicator Light

The glow-plug indicator light illuminates when you turn the key switch to the ON position and the glow plug is activated.

When the glow-plug indicator light turns off (approximately 5 to 10 seconds), you may start the engine.

Headlights Indicator

The headlights indicator illuminates when the headlights are in the ON position.

Seat Belt Indicator

The seat belt indicator illuminates when the operator does not have their seat belt fastened.

Note: If the seat belt is not fastened, the machine speed will be limited.

Fault Code Indicator

The fault code indicator illuminates and the corresponding fault code number appears when a machine fault occurs.

Important: Do not operate the machine if a fault code appears; otherwise, serious damage could occur. Contact your authorized Toro distributor.

Hour Meter / Odometer

This will switch between showing the total hours and odometer value.

The hour meter indicates the total hours of machine operation. The hour meter starts to function whenever the engine is running.

Oil-Pressure-Warning Light

The oil-pressure-warning light illuminates if the engine-oil pressure drops below a safe level while the engine is running.

Important: If the light flickers or remains on, stop the machine, shut off the engine, and check the oil level. If the oil level is low, but adding oil does not cause the light to go out when the engine is started, shut off the engine immediately, and contact your authorized Toro distributor for assistance.

Check the operation of the warning light as follows:

1. Ensure that the machine is in the P (PARK) position.
2. Turn the key switch to the ON/PREHEAT position, but do not start the engine.

Note: The oil-pressure light should illuminate. If the light does not turn on, then there is a potential malfunction in the display and/or signal.

Note: If you just started or shut off the engine, it may take a few seconds for the light to turn off or on.

Coolant-Temperature Gauge and Light

The coolant-temperature gauge registers the coolant temperature in the engine and operates only when the key switch is in the ON position.

The 8 coolant bars blink and a fault code appears if the engine overheats.

Charge Indicator

The charge indicator illuminates when the battery discharges. If the light illuminates during operation, stop the machine, shut off the engine, and check for possible causes, such as the alternator belt.

Important: If the alternator belt is loose or broken, do not operate the machine until the adjustment or repair is complete. Failure to observe this precaution may damage the engine.

Check the operation of the warning lights as follows:

- Shift the transmission lever to the P (PARK) position.
- Turn the key switch to the ON/PREHEAT position, but do not start the engine. The coolant temperature, charge indicator, and oil-pressure lights should glow. If any light does not function, there is a malfunction in the system that you must repair.

Fuel Gauge

The fuel gauge shows the amount of fuel in the tank. It displays only when key switch is in the ON position.

A single bar indicates a low fuel level and 1 flashing bar indicates that the fuel tank is nearly empty.

Tachometer

The tachometer displays the speed of the engine.

Speedometer

The speedometer registers the ground speed of the machine.

Display Button/Ground Speed Governor Control

Press the button between 0 to 3 seconds to swap the locations of tachometer and speedometer.

Press and hold the button between 3 to 10 seconds to convert the speedometer from mph to km/h.

Press and hold the button for 10 seconds or more to adjust the ground speed governor; refer to [Adjusting the Ground Speed Governor](#) (page 46).

Check-Engine Light

The check-engine light illuminates to indicate an engine malfunction.

Accelerator Pedal

Use the accelerator pedal to vary the ground speed of the machine when the transmission is in gear. Pressing down the accelerator pedal increases the engine speed and ground speed. Releasing the pedal decreases the engine speed and ground speed.

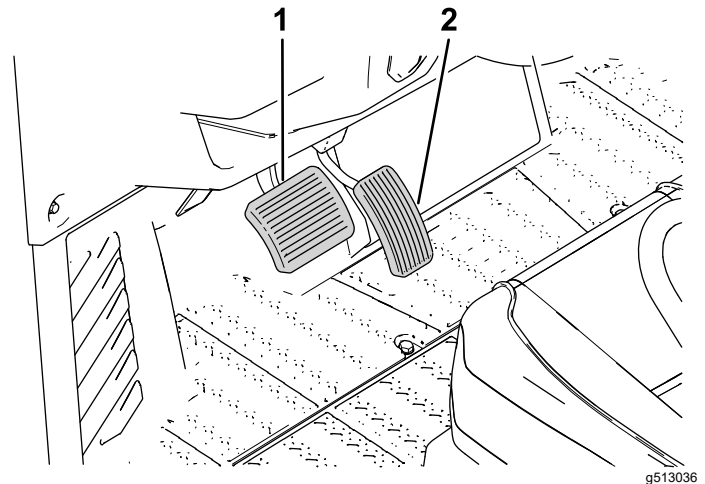

Figure 46

1. Brake pedal

2. Accelerator pedal

Brake Pedal

Use the brake pedal to stop or slow the machine.

⚠ CAUTION

Operating a machine with worn or incorrectly-bled brakes may result in personal injury.

If the brake pedal travels to within 25 mm (1 inch) of the machine floor board, bleed and/or repair the brakes.

Specifications

Note: Specifications and design are subject to change without notice.

Overall width	154 cm (60-1/2 inches)
Overall length	Model 08102/BS: 314 cm (123-1/2 inches) Model 08102TC: 314 cm (123-1/2 inches) Model 08103/BS: 405 cm (159-1/2 inches)
Curb weight —The total weight of an operational vehicle with original equipment as manufactured; filled to the maximum capacity of engine fuel, engine oil, transmission, differential fluids, and coolant; but without the weight of the operator, passenger(s), accessories, attachments, and cargo.	Model 08102/BS: 884 kg (1,949 lb) Model 08102TC: 884 kg (1,949 lb) Model 08103/BS: 994 kg (2,191 lb)
Gross vehicle weight (GVW) —The maximum allowable total vehicle weight, including the vehicle's curb weight plus the combined weights of all vehicle occupants, any cargo loads, the trailer tongue weight, and the weights of any installed options, attachments and/or accessories. Installation of options, attachments, and/or accessories may reduce the allowable cargo capacity below the stated limit.	1814 kg (4,000 lb)
Cargo bed capacity —Maximum cargo load, not including attachments and/or accessories.	Model 08102/BS: 567 kg (1,250 lb) Model 08102TC: 567 kg (1,250 lb) Model 08103/BS: 454 kg (1,000 lb)
Tow capacity	Tongue weight: 91 kg (200 lb) Maximum trailer weight: 907 kg (2,000 lb)
Ground clearance	23 cm (9 inches) with no load or operator
Wheel base	Model 08102/BS: 203 cm (80 inches) Model 08102TC: 203 cm (80 inches) Model 08103/BS: 295 cm (116 inches)
Height	201 cm (79 inches) to top of ROPS
Cargo bed length	Inside: 113 cm (44-1/2 inches) Outside: 127 cm (50 inches)
Cargo bed width	Inside: 142 cm (56 inches) Outside: 151 cm (59-1/2 inches)
Cargo bed inside height	28 cm (11 inches)
Engine speed	Low idle: 1,200 to 1,300 rpm High idle: 3,790 to 3,890 rpm

Attachments/Accessories

A selection of Toro approved attachments and accessories is available for use with the machine to enhance and expand its capabilities. Contact your Authorized Service Dealer or authorized Toro distributor or go to www.Toro.com for a list of all approved attachments and accessories.

To ensure optimum performance and continued safety certification of the machine, use only genuine Toro replacement parts and accessories.

Operation

Before Operation

Before Operation Safety

General Safety

- This vehicle is not a toy. Never allow children under 16 (unless they have obtained a state-issued motor vehicle driver's license) or people who are not trained or physically capable to safely operate or service the machine. Local regulations may restrict the age of the operator. The owner is responsible for training all operators and mechanics.
- Become familiar with the safe operation of the equipment, operator controls, and safety signs.
- Shut off the machine, remove the key, and wait for all movement to stop before you leave the operator's position. Allow the machine to cool before adjusting, servicing, cleaning, or storing it.
- Know how to stop and shut off the machine quickly.
- Ensure that there are not more occupants (you and your passenger(s)) than the number of handholds equipped on the machine. Do not carry small children on a person's lap.
- Ensure that all passengers understand and follow the instructions and warnings in the *Operator's Manual*.
- Check that all safety devices and decals are in place. Repair or replace all safety devices and replace all illegible or missing decals. Do not operate the machine unless they are present and functioning properly.

Fuel Safety

- Use extreme care in handling fuel. It is flammable and its vapors are explosive.
- Extinguish all cigarettes, cigars, pipes, and other sources of ignition.
- Use only an approved fuel container.
- Do not remove the fuel cap or fill the fuel tank while the engine is running or hot.
- Do not add or drain fuel in an enclosed space.
- Do not store the machine or fuel container where there is an open flame, spark, or pilot light, such as on a water heater or other appliance.
- If you spill fuel, do not attempt to start the engine; avoid creating any source of ignition until the fuel vapors have dissipated.

Performing Daily Maintenance

Service Interval: Before each use or daily

Before starting the machine each day, perform the Each Use/Daily procedures listed in [Daily Maintenance Checklist \(page 55\)](#).

Checking the Tire Pressure

Service Interval: Before each use or daily

⚠ DANGER

Low tire pressure decreases the side-hill stability of the machine. This could cause a rollover, which may result in personal injury or death.

Do not under-inflate the tires.

Refer to the following list for the recommended tire pressure specifications:

- **Front tire pressure:** approximately 165 kPa (24 psi)
- **Rear tire pressure with a cargo load of 227 kg (500 lb) or less:** approximately 165 kPa (24 psi)
- **Rear tire pressure with a cargo load of more than 227 kg (500 lb):** approximately 221 kPa (32 psi)

Important: Do not over-inflate the tires according to the specification listed on the sidewall of the tire.

Important: Check the tire pressure frequently to ensure proper inflation. If the tires are not inflated to the correct pressure, the tires will wear prematurely and may cause the 4-wheel drive to bind.

Figure 47 shows an example of tire wear caused by under-inflation.

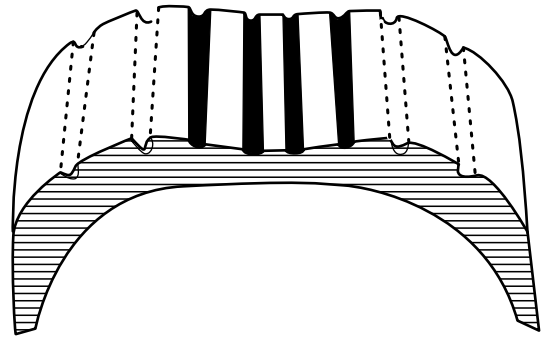

Figure 47

g395582

Figure 48 shows an example of tire wear caused by over-inflation.

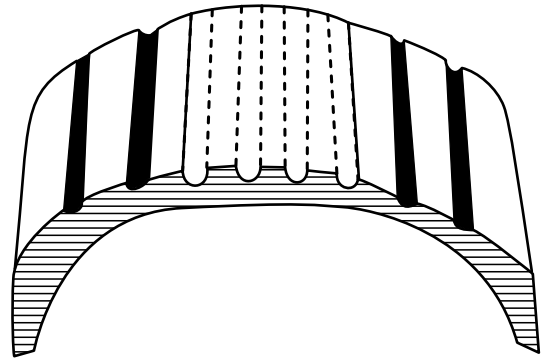

Figure 48

g395581

Adding Fuel

Recommended Fuel

The engine runs on clean, fresh diesel fuel with a minimum cetane rating of 40. Purchase fuel in quantities that you can use within 30 days to ensure fuel freshness.

Use summer-grade diesel fuel (No. 2-D) at temperatures above -7°C (20°F) and winter grade diesel fuel (No. 1-D or No. 1-D/2-D blend) below -7°C (20°F). Use of winter-grade diesel fuel at lower temperatures provides lower flash point and pour point characteristics, allowing easier starts and lessening the chances of chemical separation of the fuel due to lower temperatures.

Using summer-grade diesel fuel above -7°C (20°F) contributes toward longer life of the fuel-pump components.

Important: Never use kerosene or gasoline in place of diesel fuel. Failure to observe this caution will damage the engine.

Filling the Fuel Tank

Fuel-tank capacity: 32 L (8.5 US gallons)

1. Clean the area around the fuel-tank cap.
2. Remove the fuel-tank cap.
3. Fill the tank to approximately 25 mm (1 inch) below the bottom of the filler neck and install the cap.

Note: Do not overfill the fuel tank.

4. Install the fuel-tank cap securely.
5. Wipe up any spilled fuel.

Breaking in a New Machine

During the first 50 hours, perform the following guidelines to provide proper performance for the machine:

- After starting a cold engine, let it warm up for about 15 seconds before using the machine.

Note: Allow more time for the engine to warm up when operating in cold temperatures.

- After using the machine, allow the engine to cool down for about 15 seconds before shutting the engine off.
- Ensure that the brakes are burnished; refer to [7 Burnishing the Brakes \(page 30\)](#).
- Check the fluid levels more often during this process.
- Vary the machine speed during operation and avoid fast accelerations.
- A break-in oil for the engine is not required. Original engine oil is the same type specified for regular oil changes.

During Operation

During Operation Safety

General Safety

- The owner/operator can prevent and is responsible for accidents that may cause personal injury or property damage.
- Passengers should sit in the designated seating positions only. Do not carry passengers in the cargo bed. Keep bystanders and children out of the operating area.
- Wear appropriate clothing, including eye protection; long pants; substantial, slip-resistant footwear; and hearing protection. Tie back long hair and do not wear loose clothing or loose jewelry.
- Wear an approved helmet whenever you operate the machine on rough or uneven terrain or at high speeds.
- Use your full attention while operating the machine. Do not engage in any activity that causes distractions; otherwise, injury or property damage may occur.
- Do not operate the machine while ill, tired, or under the influence of alcohol or drugs.
- Operate the machine outdoors or in a well-ventilated area only.
- Do not exceed the maximum gross vehicle weight (GVW) of the machine.
- Use extra caution when operating, braking, or turning the machine with a heavy load in the cargo bed.
- Carrying oversized loads in the cargo bed reduces the stability of the machine. Do not exceed the carrying capacity of the bed.
- Carrying material that cannot be bound to the machine adversely affects the steering, braking, and stability of the machine. When you carry material that cannot be bound to the machine, use caution when steering or braking.
- Carry a reduced load and reduce the ground speed of the machine when operating on rough, uneven terrain, and near curbs, holes, and other sudden changes in terrain. Loads may shift, causing the machine to become unstable.
- You and your passengers should remain seated whenever the machine is moving. Keep your hands on the steering wheel; your passengers should use the handholds provided. Keep arms and legs within the machine body at all times.
- Operate the machine only in good visibility. Watch for holes, ruts, bumps, rocks, or other hidden objects. Uneven terrain could overturn the machine. Tall grass can hide obstacles. Use care when approaching blind corners, shrubs, trees, or other objects that may obscure your vision.
- Do not drive the machine near drop-offs, ditches, or embankments. The machine could suddenly roll over if a wheel goes over the edge or if the edge gives way.
- Always watch out for and avoid low overhangs such as tree limbs, door jambs, overhead walkways, etc.
- Look behind and down before reversing the machine to be sure of a clear path.
- This machine was not designed or intended to be used on public roadways. Doing so may be hazardous and in violation of local laws.
- When using the machine on public roads, follow all traffic regulations and use any additional accessories that may be required by law, such as lights, turn signals, slow-moving vehicle (SMV) signs, and others as required.
- If the machine ever vibrates abnormally, stop and shut off the machine immediately, wait for all movement to stop, and inspect for damage. Repair all damage to the machine before resuming operation.
- It can take longer to stop the machine on wet surfaces than on dry surfaces. To dry out wet brakes, drive slowly on a level surface while putting light pressure on the brake pedal.
- Operating the machine on a paved surface in different modes, such as 2-wheel drive and 4-wheel drive, and carrying passengers and cargo may affect the handling of the machine.
- Operating the machine at high speed and then quickly stopping may cause the rear wheels to lock up, which impairs your control of the machine.
- Improperly driving and/or making abrupt maneuvers while driving at fast speed increases the risk of a tip-over or rollover.
- Do not touch the engine, transmission, muffler, or exhaust manifold while the engine is running, or soon after you shut off the engine, because these areas may be hot enough to cause burns.
- Do not leave a running machine unattended.
- Before you leave the operating position, do the following:
 - Park the machine on a level surface.
 - Shift the transmission lever to the P (PARK) position.
 - Shut off the machine and remove the key.
 - Wait for all movement to stop.

- Do not operate the machine when there is the risk of lightning.
- Use accessories and attachments approved by The Toro® Company only.
- Avoid operating the machine on wet terrain. Tires may lose traction. A rollover can occur before the tires lose traction.
- Travel straight up and down a slope.

Rollover Protection System (ROPS) Safety

- The ROPS is an integral safety device. Do not remove the ROPS from the machine.
- Always wear your seat belt to prevent/minimize injury to you and your passenger(s) in the event of an accident; ensure that it is attached and that you can release it quickly in an emergency.
- Check carefully for overhead obstructions and do not contact them.
- Keep the ROPS in safe operating condition by thoroughly inspecting it periodically for damage and keeping all the mounting fasteners tight.
- Replace damaged ROPS components. Do not repair or alter them.
- If you begin to lose momentum while climbing a slope, gradually engage the brakes and slowly reverse the machine straight down the slope.
- Turning while going up or down a slope can be dangerous. If you must turn on a slope, do it slowly and cautiously.
- Heavy loads affect stability on a slope. Carry a reduced load and reduce your ground speed when operating on a slope or if the load has a high center of gravity. Secure the load to the cargo bed of the machine to prevent the load from shifting. Take extra care when hauling loads that shift easily (e.g., liquids, rock, sand, etc.).
- Avoid starting, stopping, or turning the machine on a slope, especially with a load. Stopping while going down a slope takes longer than stopping on a level surface. If you must stop the machine, avoid sudden speed changes, which can cause the machine to tip or roll over. Do not engage the brakes suddenly when rolling rearward, as this may cause the machine to overturn.

Multi-Passenger Safety

- Do not exceed the gross vehicle weight (GVW) of the machine. You must account for yourself, your passengers, and the load in the cargo bed contributing to the overall GVW of the machine.
- Passengers should sit in the designated seating positions only. Do not allow passengers to sit in the cargo bed.
- You and your passengers should remain seated with your seat belts secured whenever the machine is in motion.
- The additional machine length results in a larger turn radius, so allow more space to maneuver the machine.

Slope Safety

Slopes are a major factor related to loss-of-control and tip-over accidents, which can result in severe injury or death.

- Survey the site to determine which slopes are safe for operating the machine and establish your own procedures and rules for operating on those slopes. Always use common sense and good judgment when performing this survey.
- If you feel uneasy operating the machine on a slope, do not do it.
- Keep all movement on slopes slow and gradual. Do not suddenly change the speed or direction of the machine.

Loading and Dumping Safety

- Do not exceed the gross vehicle weight (GVW) of the machine when operating it with a load in the cargo bed and/or towing a trailer.
- Distribute the load in the cargo bed evenly to improve the stability and control of the machine.
- Before dumping, ensure that there is no one behind the machine.
- Do not dump a loaded cargo bed while the machine is sideways on a slope. The change in weight distribution may cause the machine to overturn.

Operating the Cargo Bed

Raising the Cargo Bed

⚠ WARNING

A raised bed could fall and injure persons that are working beneath it.

- Remove any load material from the bed before raising it.
- Ensure that the cargo bed is fully up and stable before working under the bed.

⚠ WARNING

Driving the machine with the cargo bed raised could cause the machine to tip or roll easier. You could damage the structure of the cargo bed if you operate the machine with the bed raised.

- Operate the machine when the cargo bed is down.
- After emptying the cargo bed, lower it.

⚠ CAUTION

If a load is concentrated near the back of the cargo bed when you release the lever, the bed may unexpectedly tip open, injuring you or bystanders.

- Center loads in the cargo bed, if possible.
- Hold the cargo bed down and ensure that no one is leaning over the bed or standing behind it when releasing the lever.
- Remove all cargo from the bed before lifting the bed up to service the machine.

Lift the lever to raise the cargo bed (Figure 49).

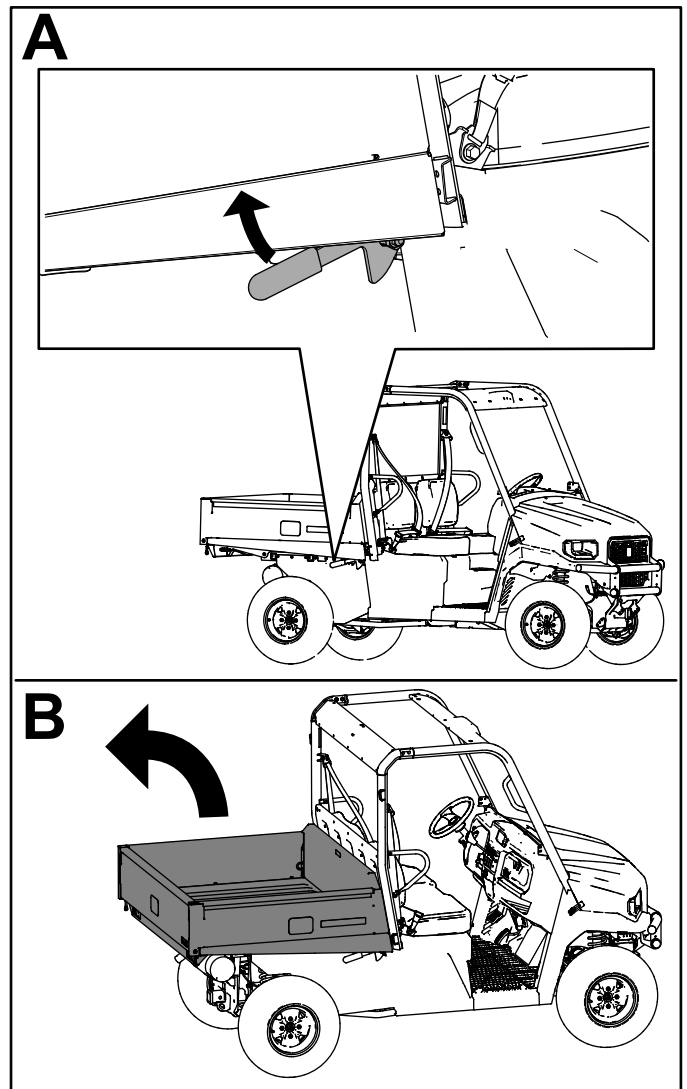

Figure 49

g398990

Lowering the Cargo Bed

⚠ WARNING

The weight of the bed may be heavy. Hands or other body parts could be crushed.

Keep your hands and other body parts away when lowering the bed.

Slowly push down the cargo bed until it latches securely.

Opening the Tailgate

1. Ensure that the cargo bed is down and latched.
2. Using both hands, raise the tailgate using the ridge near the top of the tailgate (Figure 50).

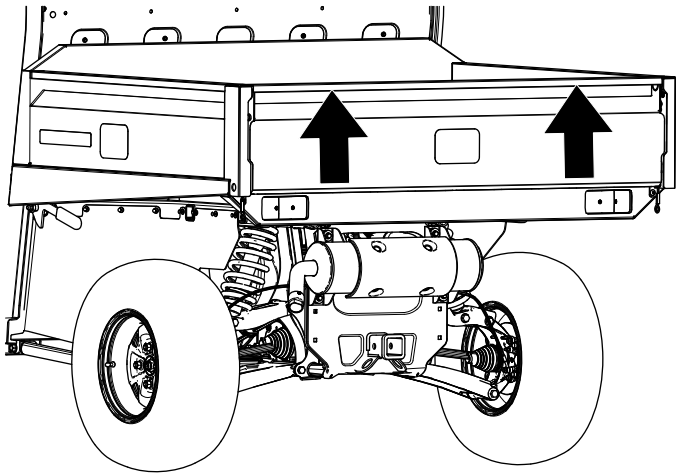

Figure 50

g356658

3. Lower the tailgate until it is flush with the bottom of the cargo bed (Figure 51).

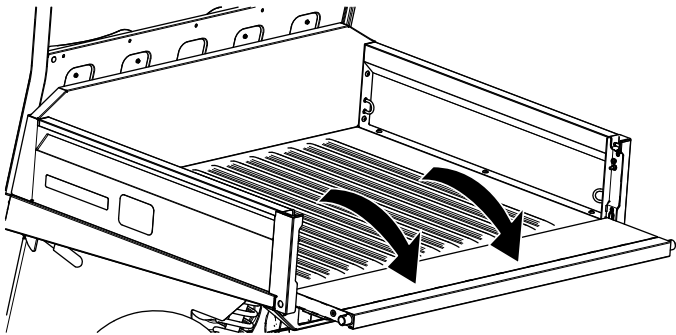

Figure 51

g356659

Closing the Tailgate

If you unloaded loose material such as sand, landscaping rock, or wood chips from the cargo bed of the machine, some of the material that you unloaded may have lodged in the hinge area of the tailgate. Perform the following steps before closing the tailgate.

1. Use your hands to remove as much of the material from the hinge area as possible.
2. Rotate the tailgate to approximately the 45° position (Figure 52).

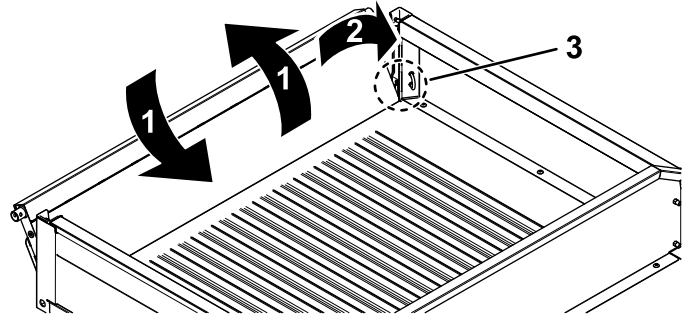

Figure 52

g356661

1. Rotate the tailgate back and forth several times.
2. Rotate the tailgate to approximately the 45° position.
3. Hinge area

3. Use a short, shaking motion to rotate the tailgate back and forth several times (Figure 52).

Note: This action helps move material away from the hinge area.

4. Lower the tailgate and check for material remaining in the hinge area.
5. Repeat steps 1 through 4 until the material is removed from the hinge area.
6. Rotate the tailgate up and lift the tailgate into the notches in the cargo bed.

Starting the Engine

Important: Do not attempt to push or tow the machine to get it started. Damage to the drive train could result.

1. Sit on the operator seat and ensure that the machine is in the P (PARK) position.
2. Rotate the key switch to the ON position.

Note: When the glow-plug-indicator light turns off (approximately 5 to 10 seconds), the engine is ready to start.

3. With your foot off the accelerator pedal, push the brake pedal.
4. Rotate the key switch to the START position.
If your foot is not on the brake pedal, you cannot start the engine.

Note: Release the key immediately when the engine starts and allow it to return to the RUN position.

Note: Do not run the starter motor for more than 10 seconds at a time or premature starter failure may result. If engine fails to start after 10 seconds, turn the key to the OFF position. Check the controls and starting procedure, wait 10 additional seconds, and repeat the starting operation.

Driving the Machine

1. Press the brake pedal.
2. Move the gear selector to the desired gear.
3. Release the brake pedal and gradually press the accelerator pedal.

Important: Always stop the machine before shifting gears.

Use the chart below to determine the ground speed of each gear when operating the machine.

Gear	Maximum speed (km/h)	Maximum speed (mph)
R (REVERSE)	0 to 24	0 to 15
H (HIGH FORWARD)	0 to 40	0 to 25
L (LOW FORWARD)	0 to 24	0 to 15

Note: Leaving the key switch in the ON position for long periods of time without starting the engine discharges the battery.

Using the Cruise Control

In order to use cruise control, your seat belt must be fastened, and you need to be driving at the following ground speed based on your selected gear:

- **H (High Forward) gear**—6 km/h (4 mph) or greater
- **L (Low Forward) gear**—3 km/h (2 mph) or greater

1. Move the cruise control switch to the ON position (Figure 53).
2. When you reach the desired drive speed, press the cruise control switch up to engage/set the cruise control (Figure 53).

To increase the cruise control speed, press the switch up until you reach the desired speed (Figure 53).

Note: Press the button 1 time to increase the ground speed by an increment of 1 km/h (1 mph).

To disengage cruise control, press the switch to the down, OFF position (Figure 53).

Note: When you press the brake pedal, the cruise control disengages.

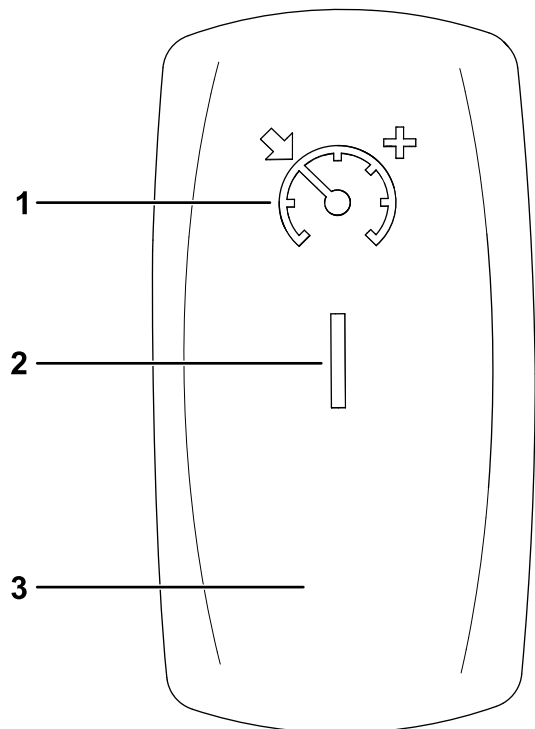

Figure 53

g391453

1. Set cruise control/increase cruise speed
2. ON position
3. OFF position

Adjusting the Ground Speed Governor

1. Press and hold the button (Figure 54) for at least 10 seconds.

The set speed will blink.

2. Press the button 1 time to increase the ground speed by an increment of 1 km/h (1 mph).

Note: The maximum ground speed that you can increase to is 40 km/h (25 mph); the minimum is 8 km/h (5 mph).

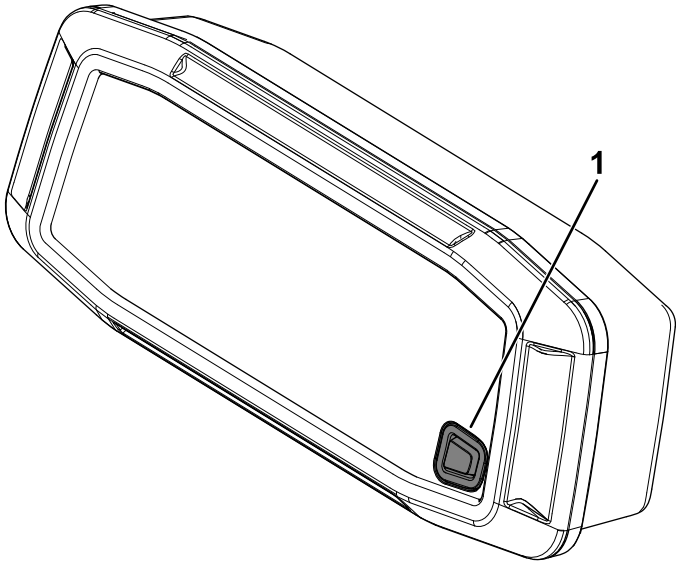

g367226

Figure 54

1. Button
-

Stopping the Machine

To stop the machine, remove your foot from the accelerator pedal, then press the brake pedal.

Shutting Off the Engine

1. Stop the machine.
2. Shift the transmission lever to the P (PARK) position.
3. Rotate the key switch to the OFF position and remove the key.

Using the 4-Wheel Drive/Differential Lock(s)

⚠ WARNING

Loss of control or damage to the machine or turf can happen if you do not properly use the 4-wheel drive/differential lock(s).

- The machine speed must be at 16 km/h (10 mph) or less to engage the 4-wheel drive.
- The machine speed must be at 8 km/h (5 mph) or less to engage the differential lock(s).
- You can release the 4-wheel drive/differential lock(s) while the machine is in motion. The 4-wheel drive/differential lock(s) may stay engaged while an axle load is present. The 4-wheel drive/differential lock(s) releases once you remove an axle load.
- Use 4-wheel drive/differential lock(s) only when necessary for improved ground engagement.

⚠ WARNING

Tipping or rolling the machine on a hill will cause serious injury.

- The extra traction available with the 4-wheel drive/differential lock(s) can be enough to get you into dangerous situations, such as climbing slopes that are too steep to turn around. Be careful when operating with the 4-wheel drive/differential lock(s) on, especially on steeper slopes.
- If the 4-wheel drive/differential lock(s) are on when making a sharp turn at a higher speed and the inside rear wheel lifts off the ground, there may be a loss of control, which could cause the machine to skid. Use the 4-wheel drive/differential lock(s) only at slower speeds.

Engaging 4-Wheel Drive

1. Ensure that the machine speed is 16 km/h (10 mph) or less and your foot is off the accelerator pedal.
2. Press the 2-wheel drive/4-wheel drive switch (Figure 55) up to engage 4-wheel drive.

Note: You can disengage 4-wheel drive at any speed.

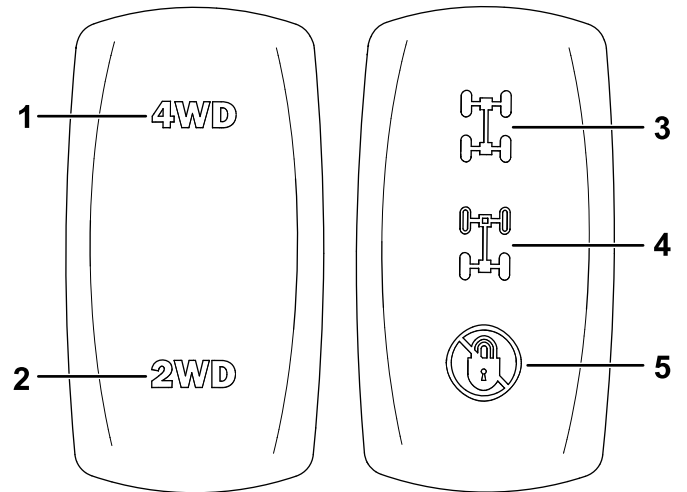

Figure 55

1. Up position—engages 4-wheel drive
2. Down position—engages 2-wheel drive
3. Up position—engages the front and rear differential locks
4. Mid position—engages the rear differential lock
5. Down position—disengages the differential lock(s)

Disengaging 4-Wheel Drive

With your foot off the accelerator pedal, disengage 4-wheel drive by pressing the 2-wheel drive/4-wheel drive switch to the down position (Figure 55).

Note: The 4-wheel drive icon will not be illuminated on the display when the switch is disengaged.

Note: You can release 4-wheel drive while the machine is in motion. 4-wheel drive may stay engaged while an axle load is present. 4-wheel drive releases once you remove an axle load.

Engaging the Differential Lock(s)

1. Ensure that the machine speed is 8 km/h (5 mph) or less and your foot is off the accelerator pedal.
2. Press the differential-lock switch to the mid position to engage the rear differential lock (Figure 55).

Press the differential-lock switch to the up position to engage the front and rear differential locks (Figure 55).

Note: The differential lock(s) are only active when the differential-lock switch is pushed.

Note: The differential-lock(s) icon appears on the display when you engage the differential lock.

Disengaging the Differential Lock(s)

With your foot off the accelerator pedal, disengage the differential lock(s) by pressing the differential-lock switch to the down position (Figure 55).

Note: The differential-lock(s) icon will not be illuminated on the display when the switch is disengaged.

Note: You can release the differential lock(s) while the machine is in motion. The differential lock(s) may stay engaged while an axle load is present. The differential lock(s) release once you remove an axle load.

Controlling the Engine Throttle While in the P (PARK) Position

If you are warming up the engine in cold weather or if you need to charge your battery using the engine, do the following:

1. Shift the transmission lever to the P (PARK) position.
2. With one foot on the brake pedal, simultaneously press your other foot on the accelerator pedal.

Note: There is no throttle control while in the N (NEUTRAL) position.

Loading the Cargo Bed

Use the following guidelines when loading the cargo bed and operating the machine:

- Observe the weight capacity of the machine and limit the weight of the load that you carry in the cargo bed as described in [Specifications \(page 37\)](#) and on the gross vehicle weight tag of the machine.
- **Note:** The load rating is specified for machine operation on a level surface only.
- Reduce the weight of the load that you carry in the cargo bed when operating the machine on hills and rough terrain.
- Reduce the weight of the load that you carry when the materials are tall (and have a high center of gravity), such as a stack of bricks, landscaping timbers, or fertilizer bags. Distribute the load as low as possible to ensure that the load does not reduce your ability to see behind the machine when operating it.
- Keep loads centered by loading the cargo bed as follows:

- Evenly position the weight in the cargo bed from side to side.

Important: Tipping over is more likely to occur if the cargo bed is loaded to 1 side.

- Evenly position the weight in the cargo bed from front to back.

Important: Loss of steering control or the machine may tip over if you position the load behind the rear axle and the traction on the front tires is reduced.

- Use extra caution when transporting oversized loads in the cargo bed, particularly when you cannot center the weight of the oversize load to the cargo bed.
- Whenever possible, secure the load by binding it to the cargo bed so that it does not shift.
- When transporting liquids, use caution when driving the machine uphill or downhill, when suddenly changing speed or stopping, or when driving over rough surfaces.

The capacity of the cargo bed is 0.45 m³ (15.9 ft³). The amount (volume) of material that you can place in the bed without exceeding the load ratings of the machine can vary greatly depending on the density of the material.

Refer to the following table for load volume limits with various materials:

Material	Density	Maximum Cargo Box Capacity (on level ground)
Gravel, dry	1522 kg/m ³ (95 lb/ft ³)	Full
Gravel, wet	1922 kg/m ³ (120 lb/ft ³)	3/4 Full
Sand, dry	1442 kg/m ³ (90 lb/ft ³)	Full
Sand, wet	1922 kg/m ³ (120 lb/ft ³)	3/4 Full
Wood	721 kg/m ³ (45 lb/ft ³)	Full
Bark	<721 kg/m ³ (<45 lb/ft ³)	Full
Earth, packed	1602 kg/m ³ (100 lb/ft ³)	3/4 Full (approximately)

After Operation

After Operation Safety

General Safety

- Before you leave the operating position, do the following:
 - Park the machine on a level surface.
 - Shift the transmission lever to the P (PARK) position.
 - Shut off the machine and remove the key.
 - Wait for all movement to stop.
- Allow the machine to cool before adjusting, servicing, cleaning, or storing it.
- Do not store the machine where there is an open flame, spark, or pilot light, such as on a water heater or other appliance.
- Keep all parts of the machine in good working condition and all hardware tightened.
- Maintain and clean the seat belt(s) as necessary.
- Replace all worn, damaged, or missing decals.

Hauling the Machine

- Use care when loading or unloading the machine into a trailer or a truck.
- Use full-width ramps for loading the machine into a trailer or a truck.
- Tie the machine down securely.

Refer to [Figure 56](#) and [Figure 57](#) for the tie-down locations on the machine.

Note: Load the machine on the trailer with the front of the machine facing forward.

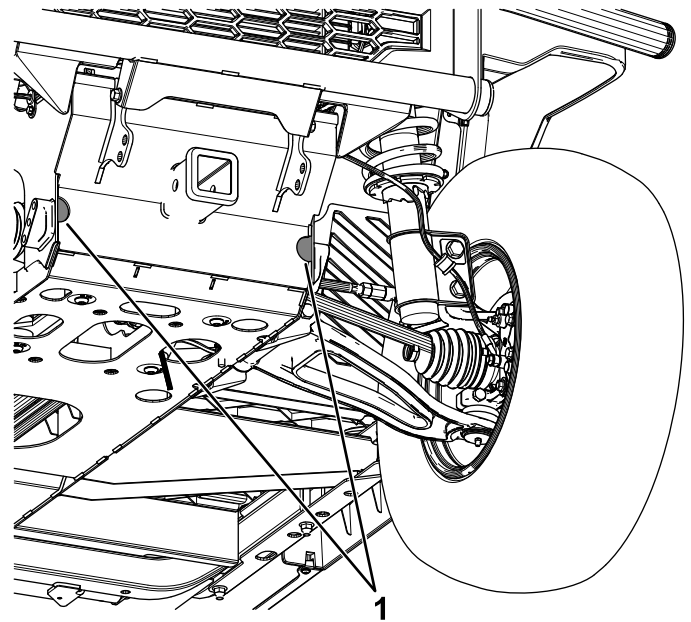

Figure 56

g356657

1. Front tie-down locations

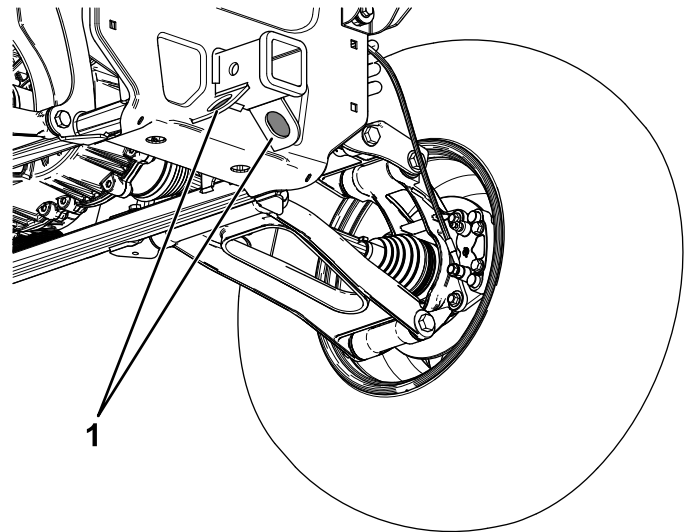

Figure 57

g356660

1. Rear tie-down locations

Towing the Machine

In case of an emergency, you can tow the machine for a short distance; however, this is not the standard operating procedure.

▲ WARNING

Towing at excessive speeds could cause a loss of steering control, resulting in personal injury.

Never tow the machine at faster than 8 km/h (5 mph).

Note: The power steering may not function, making it difficult to steer.

Towing the machine is a 2-person job. If you must move the machine a considerable distance, transport it on a truck or trailer.

1. Affix a tow line to the tongue at the front of the frame of the machine (Figure 56).
2. Move the gear selector to the N (NEUTRAL) position.

Towing a Trailer

The machine is capable of pulling trailers and attachments. Contact your authorized Toro distributor for the available tow hitches.

Your machine can tow trailers with a maximum gross trailer weight (GTW) up to 907 kg (2,000 lb).

Always load a trailer with approximately 60% of the trailer cargo weight toward the front of the trailer axle. Do not exceed 91 kg (200 lb) of tongue weight on the tow hitch of the machine.

When hauling cargo or towing a trailer, do not overload the machine or trailer. Overloading can cause poor performance or damage to the brakes, axle, engine, transaxle, steering, suspension, body structure, or tires.

Important: To reduce the potential for drive belt damage, use the L (LOW RANGE) position when towing.

Maintenance

Maintenance Safety

- Do not allow untrained personnel to service the machine.
- Before you leave the operating position, do the following:
 - Park the machine on a level surface.
 - Shift the transmission lever to the P (PARK) position.
 - Shut off the machine and remove the key.
 - Wait for all movement to stop.
- Allow the machine to cool before adjusting, servicing, cleaning, or storing it.
- Support the machine with jack stands whenever you work under the machine.
- Do not work under a raised bed without the proper bed safety support in place.
- To ensure that the entire machine is in good condition, keep all hardware properly tightened.
- To reduce the potential fire hazard, keep the machine area free of excessive grease, grass, leaves, and accumulation of dirt.
- If possible, do not perform maintenance while the machine is running. Keep away from moving parts.
- If you must run the machine to perform a maintenance adjustment, keep your hands, feet, clothing, and any parts of the body away from any moving parts. Keep bystanders away from the machine.
- Clean up oil and fuel spills.
- Keep all parts of the machine in good working condition and all the hardware properly tightened. Replace all worn or damaged decals.
- Never interfere with the intended function of a safety device or reduce the protection provided by a safety device.
- Do not overspeed the engine by changing the governor settings. To ensure safety and accuracy, have an authorized Toro distributor check the maximum engine speed with a tachometer.
- If major repairs are ever necessary or assistance is required, contact an authorized Toro distributor.
- Altering this machine in any manner may affect the operation of the machine, performance, durability, or its use may result in injury or death. Such use could void the product warranty of The Toro® Company.

Recommended Maintenance Schedule(s)

Maintenance Service Interval	Maintenance Procedure
After the first 50 hours	<ul style="list-style-type: none"> • Check and adjust the alternator belt. • Torque the wheel-lug nuts.
Before each use or daily	<ul style="list-style-type: none"> • Check the seat belt(s) for wear, cuts, and other damage. Replace the seat belt(s) if any component does not operate properly. • Check the tire pressure. • Check the engine-oil level. • Check the level of the coolant. • Remove debris from the engine area and radiator. • Check the brake-fluid level. Check the brake-fluid level before you start the engine.
Every 100 hours	<ul style="list-style-type: none"> • Check the condition of the wheels and tires. • Check the steering and suspension for loose or damaged components. • Check the front wheel alignment. • Check the brakes.
Every 250 hours	<ul style="list-style-type: none"> • Grease the machine (lubricate more frequently in heavy-duty applications). • Change the air-cleaner filter (more frequently in dusty or dirty conditions). • Change the engine oil and filter. • Check and adjust the alternator belt. • Torque the wheel-lug nuts. • Check the transaxle-fluid level. • Check the condition of the drive belt and clean the clutches.
Every 500 hours	<ul style="list-style-type: none"> • Calibrate the throttle actuator. • Change the canister for the fuel filter/water separator (more often in dirty and dusty conditions). • Check the fuel lines and connections. • Change the transaxle fluid. • Check the front differential oil level. • Check the coolant hoses for cracks, swelling, or deterioration. • Replace the drive belt.
Every 1,000 hours	<ul style="list-style-type: none"> • Change the front differential oil. • Change the engine coolant. • Change the brake fluid.

Note: Download a free copy of the electrical schematic by visiting www.Toro.com and searching for your machine from the Manuals link on the home page.

Important: Refer to your engine owner's manual for additional maintenance procedures.

⚠ WARNING

Failing to properly maintain the machine could result in premature failure of machine systems, causing possible harm to you or bystanders.

Keep the machine well maintained and in good working order as indicated in these instructions.

⚠ CAUTION

Only qualified and authorized personnel should maintain, repair, adjust, or inspect the machine.

- Avoid fire hazards and have fire-protection equipment present in the work area. Do not use an open flame to check fluid levels or leakage of fuel, battery electrolyte, or coolant.
- Do not use open pans of fuel or flammable cleaning fluids for cleaning parts.

⚠ CAUTION

If you leave the key in the switch, someone could accidentally start the engine and seriously injure you or other bystanders.

Shut off the engine and remove the key from the switch before you perform any maintenance.

Daily Maintenance Checklist

Duplicate this page for routine use.

Maintenance Check Item	For the week of:						
	Monday	Tuesday	Wednesday	Thursday	Friday	Saturday	Sunday
Check the operation of the gear selector.							
Check the fuel level.							
Check the engine-oil level.							
Check the brake-fluid level.							
Check the transaxle-fluid level.							
Check the air filter.							
Check the engine-cooling fins.							
Check for unusual engine noises.							
Check for unusual operating noises.							
Check the tire pressure.							
Check for fluid leaks.							
Check the instrument operation.							
Check the accelerator operation.							
Wash the machine.							
Touch up any damaged paint.							

Maintaining the Machine under Special Operating Conditions

Important: If the machine is subjected to any of the conditions listed below, perform maintenance twice as frequently:

- Desert operation
- Cold climate operation—below 10°C (50°F)
- Trailer towing
- Frequent operation in dusty conditions
- Construction work
- After extended operation in mud, sand, water, or similar dirty conditions, do the following:
 - Have your brakes inspected and cleaned as soon as possible. This prevents any abrasive material from causing excessive wear.
 - Wash the machine using water alone or with a mild detergent.

Important: Do not use brackish or reclaimed water to clean the machine.

Pre-Maintenance Procedures

Preparing the Machine for Maintenance

1. Park the machine on a level surface.
2. Shift the transmission lever to the P (PARK) position.
3. Raise and empty the cargo bed.
4. Shut off the engine and remove the key.
5. Allow the machine to cool before performing maintenance.
6. Disconnect the negative (-) battery cable from the battery post.

Raising the Machine

⚠ DANGER

A machine on a jack may be unstable and slip off the jack, injuring anyone beneath it.

- Do not start the machine while the machine is on a jack, as the engine vibration or wheel movement could cause the machine to slip off the jack.
- Always remove the key from the key switch before getting off the machine.
- Block the tires when the machine is on a jack.

When jacking up the front of the machine, always place a wooden block (or similar material) between the jack and the machine frame.

The jacking point at the front of the machine is located at the front frame bottom plate (Figure 58).

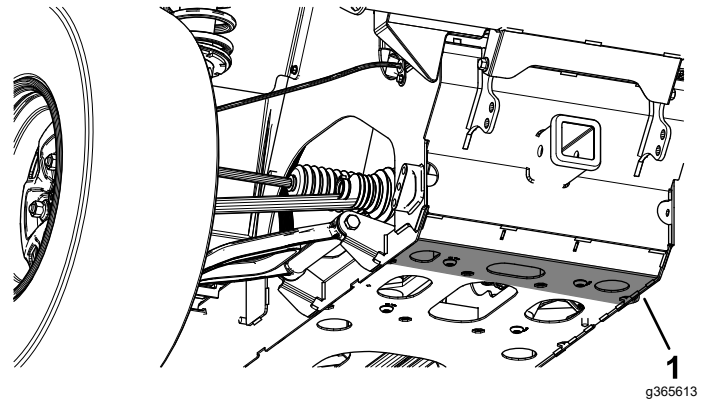

Figure 58

1. Front jacking point

The jacking point at the rear of the machine is located at the rear cradle bracket (Figure 59).

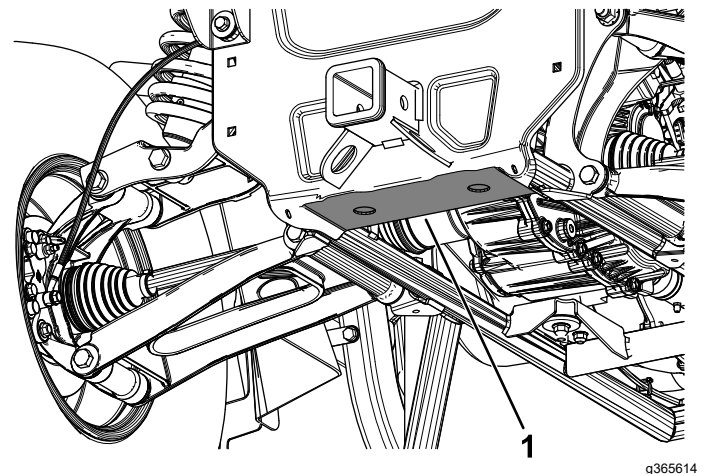

Figure 59

1. Rear jacking point

Accessing the Hood

Raising the Hood

1. Lift up the handle of the rubber latches on each side of the hood.
2. Raise the hood.

Closing the Hood

1. Gently lower the hood.
2. Secure the hood by aligning the rubber latches onto the latch anchors on each side of the hood ([Figure 60](#)).

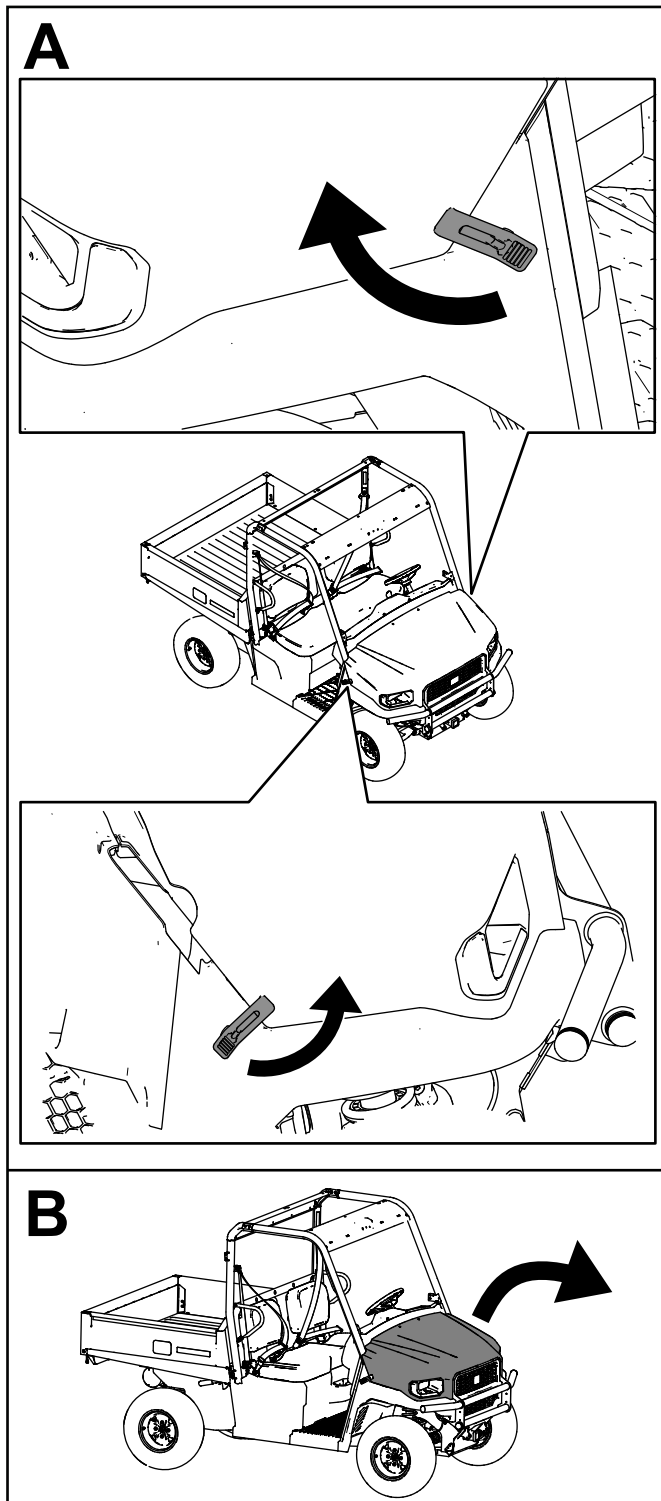

Figure 60

g398991

Lubrication

Greasing the Machine

Service Interval: Every 250 hours—Grease the machine (lubricate more frequently in heavy-duty applications).

Grease Type: No. 2 lithium grease

1. Use a rag to wipe the grease fitting clean so that foreign matter cannot be forced into the bearing or bushing.
2. With a grease gun, apply grease into the grease fittings on the machine.
3. Wipe any excess grease off the machine.

The grease fitting locations and quantities are as follows:

- **Front control arm pivots (2);** refer to [Figure 61](#)

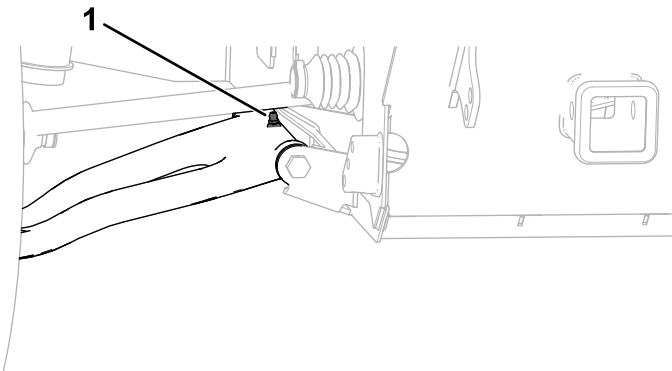

Figure 61
Right side shown

g390951

1. Front control arm pivot grease fitting

- **Rear control arm pivots (4);** refer to [Figure 62](#)

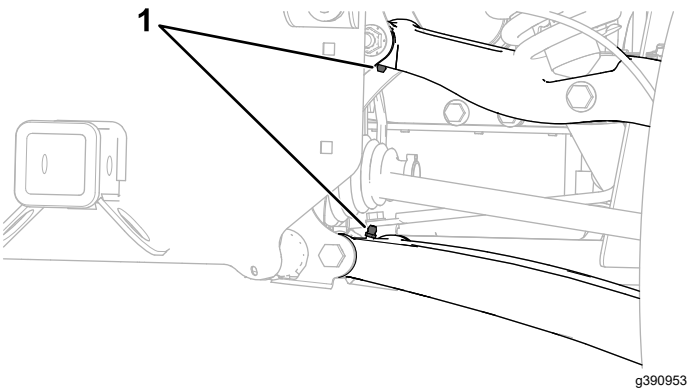

Figure 62
Right side shown

g390953

1. Rear control arm pivots grease fittings

- **Ball joints (2);** refer to [Figure 63](#)

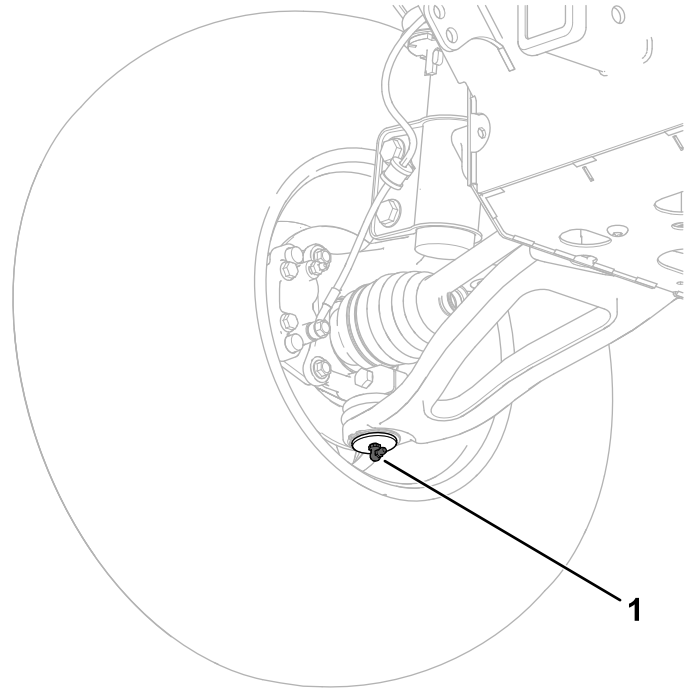
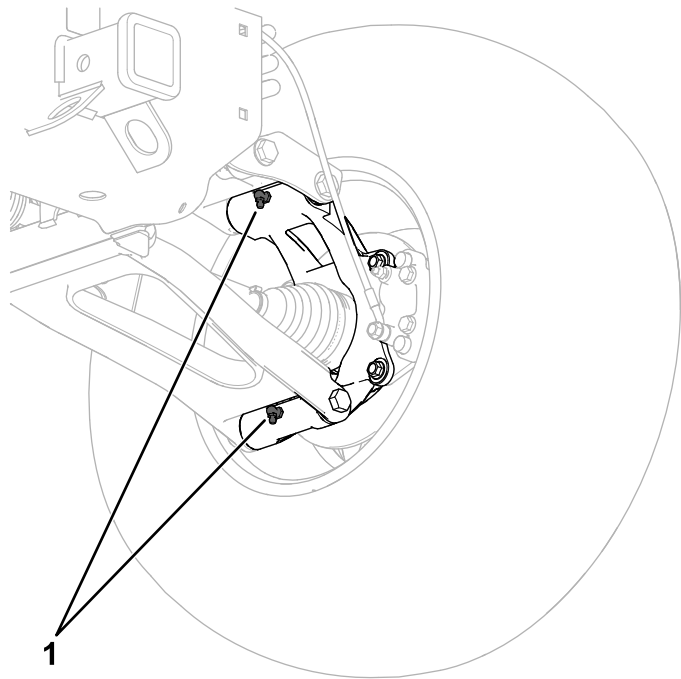

Figure 63
Right side shown

g390950

1. Ball joint grease fitting

- **Rear knuckle pivots (4);** refer to [Figure 64](#)



g390952

Figure 64
Right side shown

1. Rear knuckle pivots grease fittings

- **Drive shaft (2);** refer to [Figure 65](#)

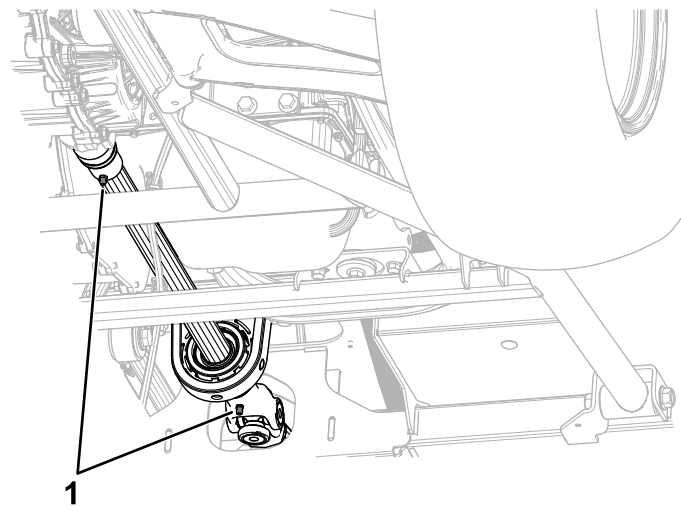

g357005

Figure 65

1. Drive shaft grease fittings

Engine Maintenance

Engine Safety

- Shut off the engine, remove the key, and wait for all moving parts to stop before checking the oil or adding oil to the crankcase.
- Keep your hands, feet, face, clothing, and other body parts away from the muffler and other hot surfaces.

Servicing the Air Cleaner

Service Interval: Every 250 hours—Change the air-cleaner filter (more frequently in dusty or dirty conditions).

Inspect the air cleaner and hoses periodically to maintain maximum engine protection and to ensure maximum service life. Check the air-cleaner body for damage that could possibly cause an air leak. Replace a damaged air-cleaner body.

1. Release the latches on the air cleaner and pull the air-cleaner cover off the air-cleaner body (Figure 66).

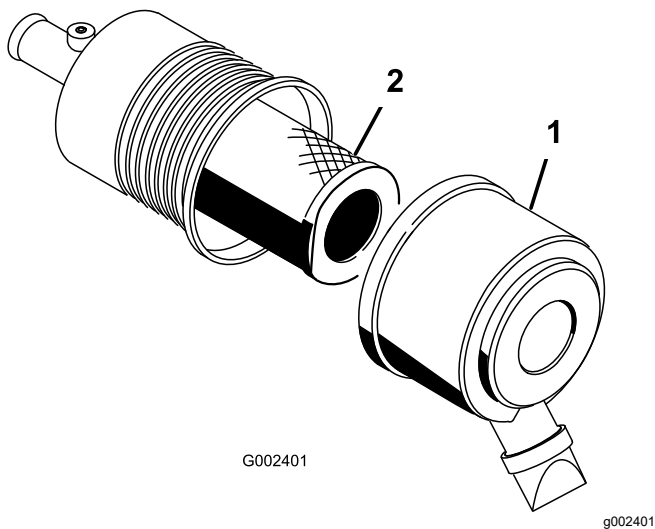

Figure 66

1. Air-cleaner cover
2. Filter

2. Squeeze the dust cap sides to open it and knock the dust out.
3. Gently slide the filter out of the air-cleaner body (Figure 66).

Note: Avoid knocking the filter into the side of the body.

Note: Do not attempt to clean the filter.

4. Inspect the new filter for damage by looking into the filter while shining a bright light on the outside of the filter.

Note: Holes in the filter appear as bright spots. Inspect the element for tears, an oily film, or damage to the rubber seal. If the filter is damaged, do not use it.

Note: To prevent engine damage, always operate the engine with the air filter and cover installed.

5. Carefully slide the filter over the body tube (Figure 66).

Note: Ensure that it is fully seated by pushing on the outer rim of the filter while installing it.

6. Install the air-cleaner cover with the side facing up, and secure the latches (Figure 66).

Servicing the Engine Oil

Service Interval: Before each use or daily

Every 250 hours—Change the engine oil and filter.

Note: Change the oil more frequently when operating conditions are extremely dusty or sandy.

Note: Dispose of the used engine oil and oil filter at a certified recycling center.

Engine-Oil Specifications

The engine ships with oil in the crankcase; however, check the oil level before you first start the engine. Check the oil level before operating the machine each day or each time you use the machine.

Oil Type: Toro Premium Engine Oil

If using an alternate oil, use high-quality, low-ash engine oil that meets or exceeds the following specifications:

- API service category CJ-4 or higher
- ACEA service category E6
- JASO service category DH-2

Important: Using engine oil other than API classification CJ-4 or higher, ACEA E6, or JASO DH-2 may cause the diesel particulate filter to plug or cause engine damage.

Crankcase Capacity: 2.3 L (2.4 US qt) when the filter is changed

Oil Viscosity/Grade: SAE 10W-30 (all temperatures)

Note: Toro Premium Engine oil is available from your distributor. See the *Parts Catalog* or contact an authorized Toro distributor for part numbers.

Checking the Engine-Oil Level

1. Park the machine on a level surface.
2. Shift the transmission lever to the P (PARK) position.
3. Shut off the engine and remove the key.
4. Raise the cargo bed.
5. Check the engine-oil level as shown in [Figure 67](#).

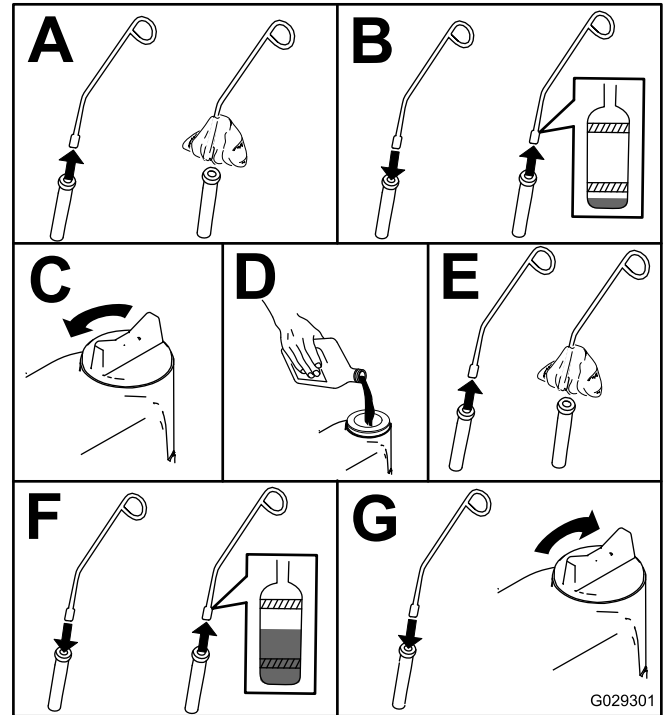

Figure 67

Changing the Engine Oil and Filter

If possible, run the engine just before changing the oil because warm oil flows better and carries more contaminants than cold oil.

1. Park the machine on a level surface.
2. Shift the transmission lever to the P (PARK) position.
3. Shut off the engine and remove the key.
4. Raise the cargo bed.

5. Change the engine oil as shown in [Figure 68](#).

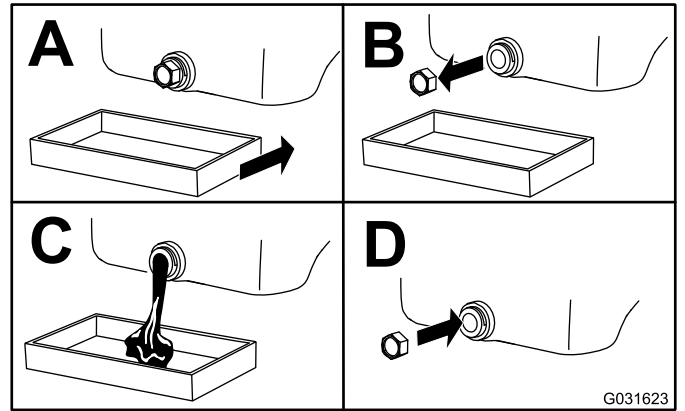

Figure 68

6. Replace the engine-oil filter as shown in [Figure 69](#).

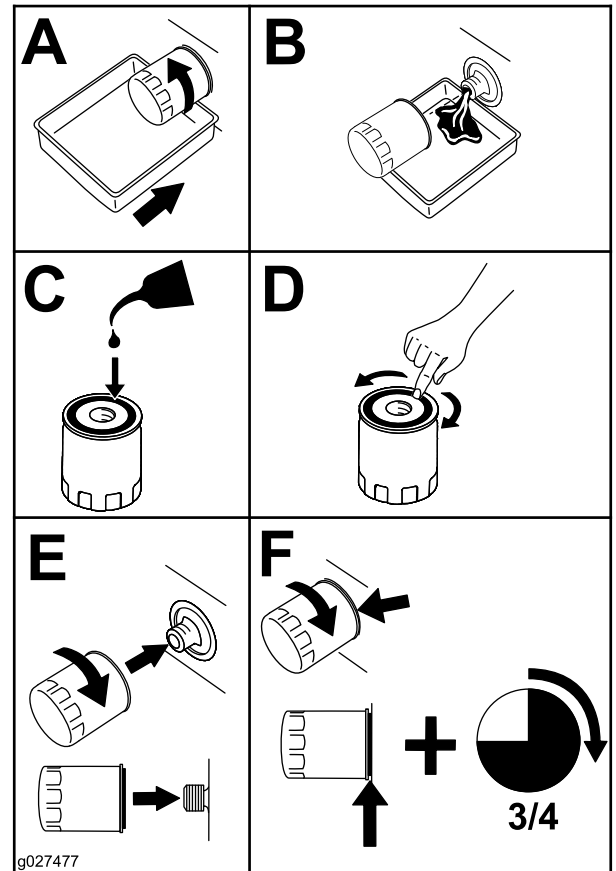

Figure 69

7. Fill the crankcase with oil; refer to [Engine-Oil Specifications](#) (page 61).

Checking and Adjusting the Alternator Belt

Service Interval: After the first 50 hours—Check and adjust the alternator belt.

Every 250 hours—Check and adjust the alternator belt.

1. Press the belt inward using your finger or a ruler with a force of approximately 98 N (22 lbf) to check the deflection.

There are 3 positions to check the belt tension ([Figure 70](#)). The correct deflection at each position is as follows:

- **Position 1**—9 to 13 mm (5/16 to 1/2 inch)
- **Position 2**—7 to 10 mm (1/4 to 3/8 inch)
- **Position 3**—10 to 14 mm (3/8 to 1/2 inch)

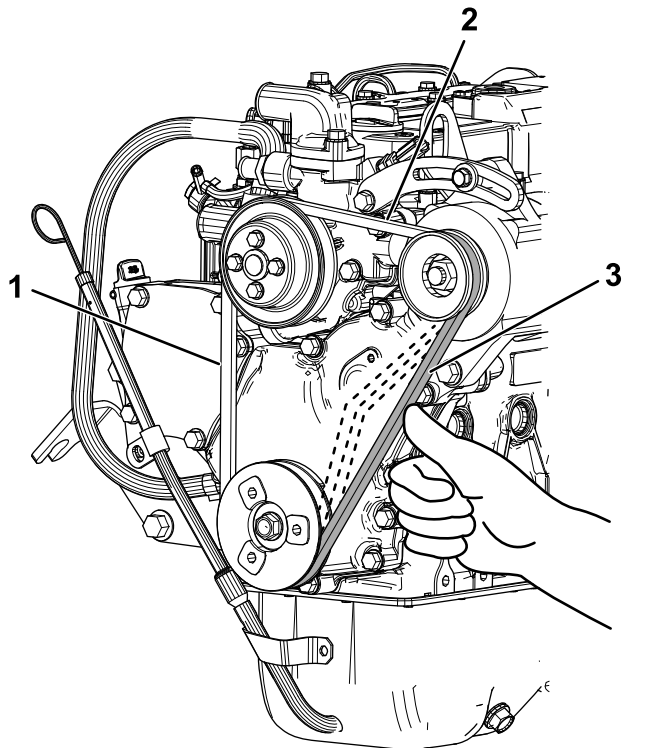

Figure 70

g366704

- | | |
|----------------------------------|----------------------------------|
| 1. 9 to 13 mm (5/16 to 1/2 inch) | 3. 10 to 14 mm (3/8 to 1/2 inch) |
| 2. 7 to 10 mm (1/4 to 3/8 inch) | |

2. If needed, adjust the belt tension as follows:
3. Loosen the adjusting bolts and nuts, then move the alternator using a wrench to tighten the belt to the correct tension ([Figure 71](#)).
4. Tighten the adjusting bolts and nuts ([Figure 71](#)).

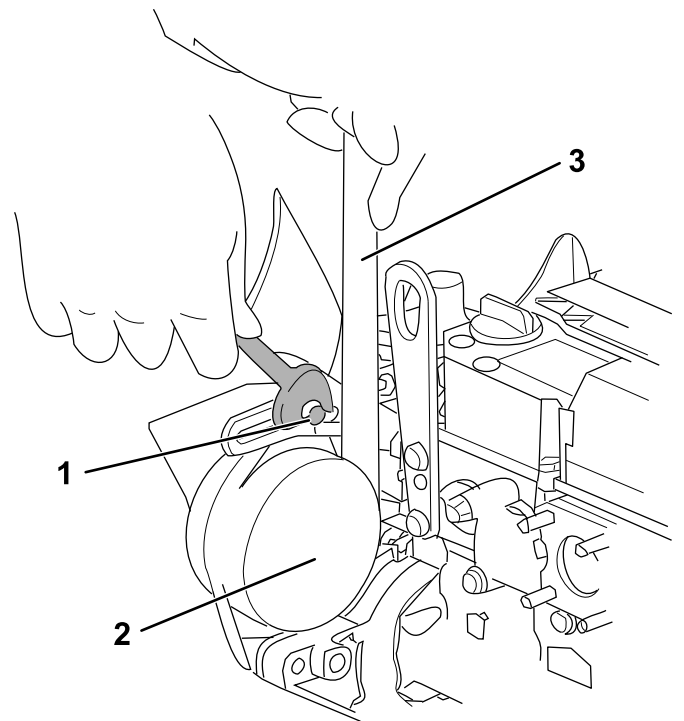

Figure 71

g366768

- | | |
|-------------------|-----------|
| 1. Adjusting bolt | 3. Wrench |
| 2. Alternator | |

5. Tighten the belt to the correct tension.

Ensure that there is clearance between the belt and the bottom of the pulley groove. If there is no clearance between the belt and the bottom of the pulley groove, replace the belt ([Figure 72](#)).

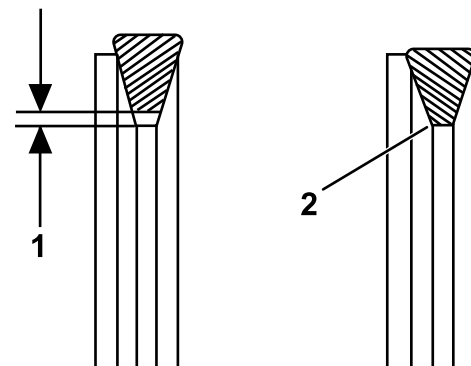

Figure 72

g366767

- | | |
|---|--|
| 1. Example of clearance between the belt and the bottom of the pulley groove | 2. Example of no clearance between the belt and the bottom of the pulley groove |
|---|--|

6. Check the belt for cracks, oil, and/or wear. Replace, if necessary.

Calibrating the Throttle Actuator

Service Interval: Every 500 hours—Calibrate the throttle actuator.

1. Park the machine on a level surface.
2. Shift the transmission lever to the P (PARK) position.
3. With the engine running and your foot off the brake pedal, press and hold the display button for 10 seconds (Figure 73).

The km/h or mph on the display will start blinking.

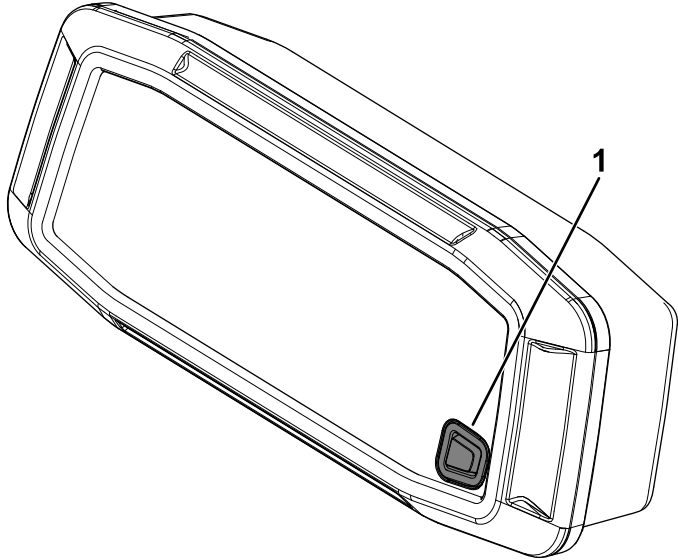

Figure 73

g367226

1. Display button

4. While pressing and holding the display button, turn the key switch from the RUN position to the START position, then simultaneously let go of both.

The throttle actuator angle will start to increase (1 degree every 2 seconds). When the calibration process is complete, a new offset is created, and the angle on the display shows zero again.

The calibration process takes approximately 30 to 60 seconds to complete.

Note: Do not touch anything during the calibration process, as this will cancel the process, requiring you to restart the procedure.

Note: During calibration, the engine speed (rpm) should remain constant. Only at the end of the calibration process you may hear the engine speed slightly increase. If the engine speed increases continuously, there may be an issue, and the engine speed is not communicating with the TEC controller.

Fuel System Maintenance

Changing the Fuel Filter/Water Separator

Service Interval: Every 500 hours—Change the canister for the fuel filter/water separator (more often in dirty and dusty conditions).

Checking the Fuel Lines and Connections

Service Interval: Every 500 hours/Yearly (whichever comes first)

Check the fuel lines, fittings, and clamps for signs of leaking, deterioration, damage, or loose connections.

Note: Repair any damaged or leaking fuel system component before using the machine.

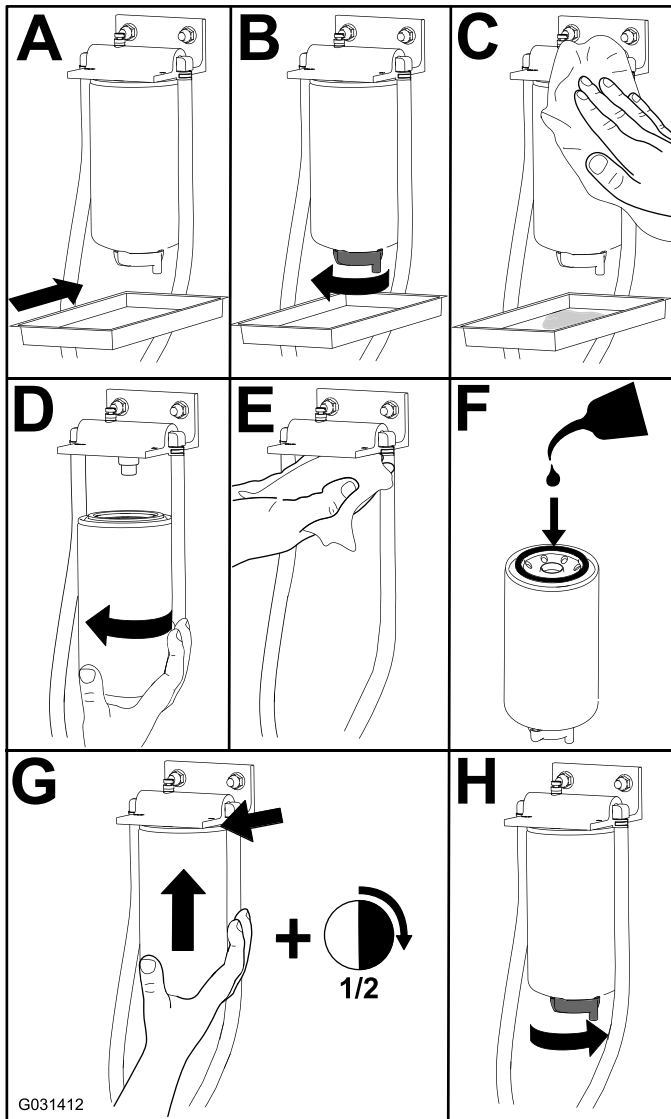

Figure 74

Electrical System Maintenance

Electrical System Safety

- Disconnect the battery before repairing the machine. Disconnect the negative terminal first and the positive last. Connect the positive terminal first and the negative last.
- Charge the battery in an open, well-ventilated area, away from sparks and flames. Unplug the charger before connecting or disconnecting the battery. Wear protective clothing and use insulated tools.

Servicing the Battery

Battery voltage: 12 V with 300 A (cold-cranking) at -18°C (0°F).

- Always keep the battery clean and fully charged.
- If the battery terminals are corroded, clean them with a solution of 4 parts water and 1 part baking soda.
- Apply a light coating of grease to the battery terminals to prevent corrosion.

⚠ DANGER

Battery electrolyte contains sulfuric acid, which is fatal when consumed and causes severe burns.

- Do not drink electrolyte and avoid contact with skin, eyes, or clothing. Wear eye protection and rubber gloves.
- Fill the battery wherever clean water is available for flushing the skin.
- Charge the battery in a well-ventilated place so that the gasses produced while charging can dissipate.
- Since the gasses are explosive, keep open flames and electrical sparks away from the battery; do not smoke near the battery.
- Nausea may result if you inhale the gasses.
- Unplug the charger from the electrical outlet before connecting the charger leads to or disconnecting them from the battery posts.

Disconnecting the Battery

⚠ WARNING

Battery terminals or metal tools could short against metal machine components, causing sparks. Sparks can cause the battery gasses to explode, resulting in personal injury.

- When removing or installing the battery, do not allow the battery terminals to touch any metal parts of the machine.
- Do not allow metal tools to short between the battery terminals and metal parts of the machine.

Disconnect the negative (-) battery cable from the battery post (Figure 75).

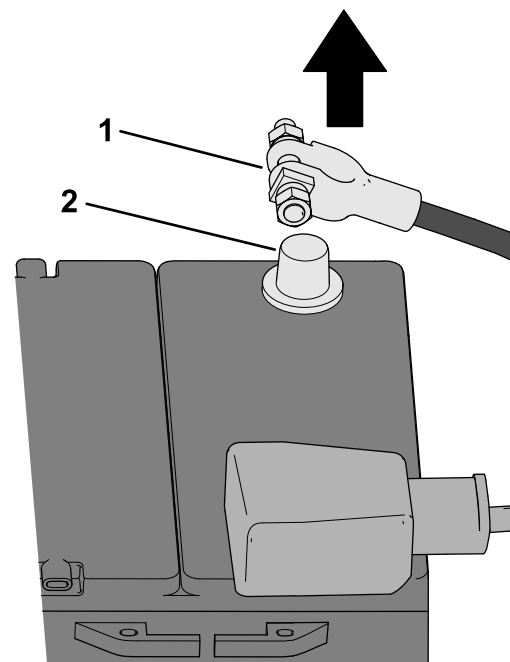

Figure 75

1. Negative (-) battery cable 2. Battery post

g365494

Removing the Battery

⚠ WARNING

Incorrect battery cable routing could damage the machine and cables, causing sparks. Sparks can cause the battery gases to explode, resulting in personal injury.

- Always disconnect the negative (black) battery cable before disconnecting the positive (red) cable.
- Always connect the positive (red) battery cable before connecting the negative (black) cable.

1. Disconnect the battery cables (Figure 76).

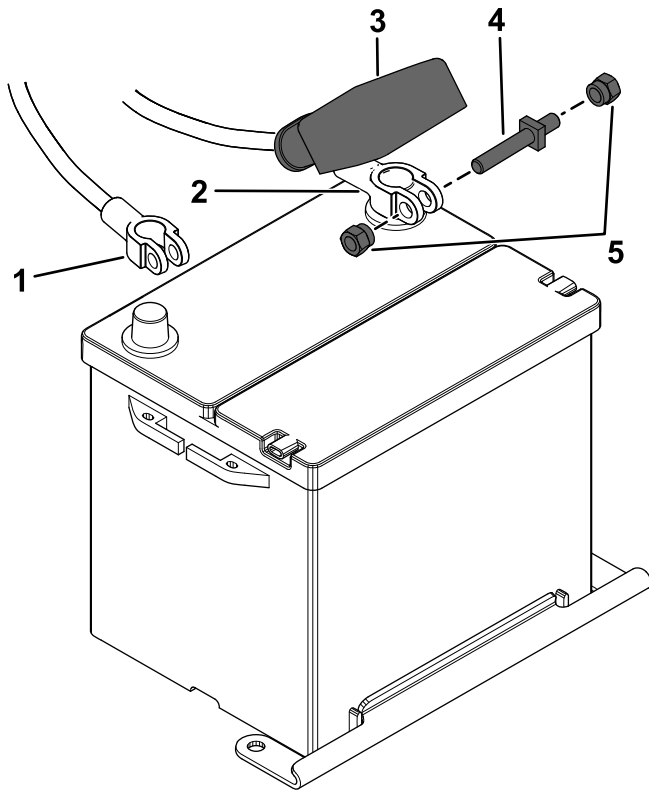

Figure 76

g464081

1. Negative battery cable (black)
2. Positive battery cable (red)
3. Insulator boot (positive battery cable)
4. Bolt
5. Nuts

2. Loosen the locknut securing the battery retainer and remove the battery from the tray (Figure 77).

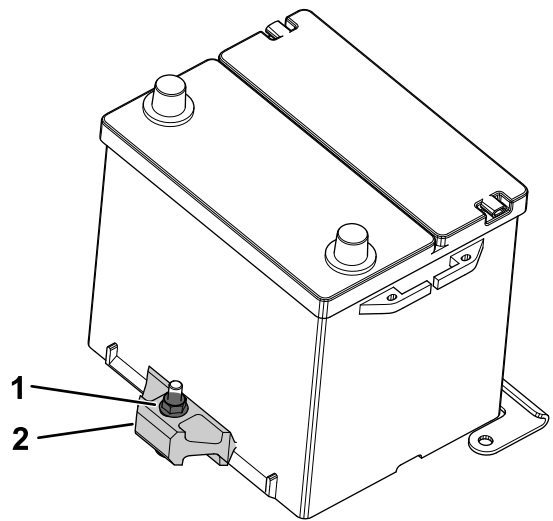

Figure 77

g463677

1. Locknut
2. Battery retainer

Installing the Battery

1. Place the battery on the battery tray and secure the battery to the retainer by tightening the locknut (Figure 77).
2. Connect the battery cables (Figure 76).

Connecting the Battery

Connect the negative (-) battery cable to the battery post (Figure 78).

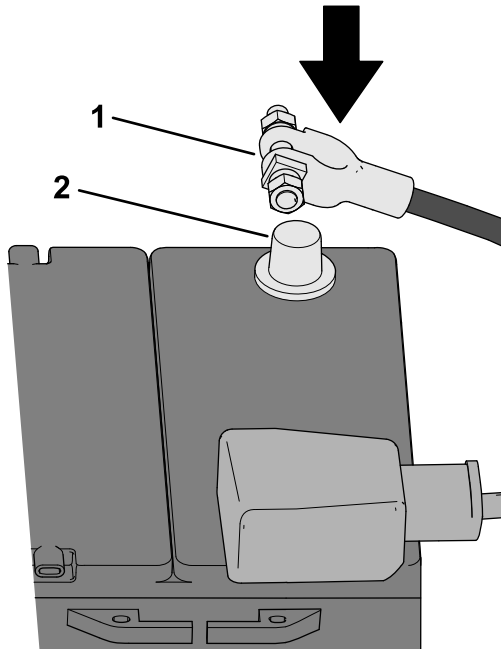

Figure 78

g365493

1. Negative (-) battery cable 2. Battery post
-

Charging the Battery

⚠ WARNING

Charging the battery produces gasses that can explode.

- Keep sparks and flames away from the battery.
- Never smoke near the battery.

Important: Always keep the battery fully charged. This is especially important to prevent battery damage when the temperature is below 0°C (32°F).

1. Remove the battery from the machine; refer to [Removing the Battery \(page 67\)](#).
2. Connect a 3 to 4 A battery charger to the battery posts. Charge the battery at a rate of 3 to 4 A for 4 to 8 hours (12 V).

Note: Do not overcharge the battery.

3. Install the battery; refer to [Installing the Battery \(page 67\)](#).

Storing the Battery

If you store the machine for more than 30 days, remove the battery and charge it fully. Either store it on the shelf or on the machine. Leave the cables disconnected if it is stored on the machine. Store the battery in a cool atmosphere to avoid quick deterioration of the charge in the battery. To prevent the battery from freezing, make sure it is fully charged.

Servicing the Fuses

The fuses for the electrical system are located underneath the seat (Figure 79).

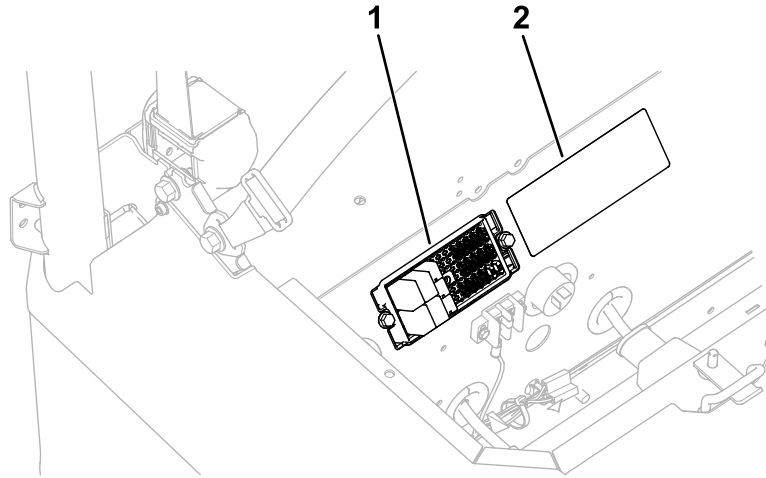

Figure 79

g388509

1. Fuse block

2. Fuse decal

Refer to Figure 80 for the fuse locations.

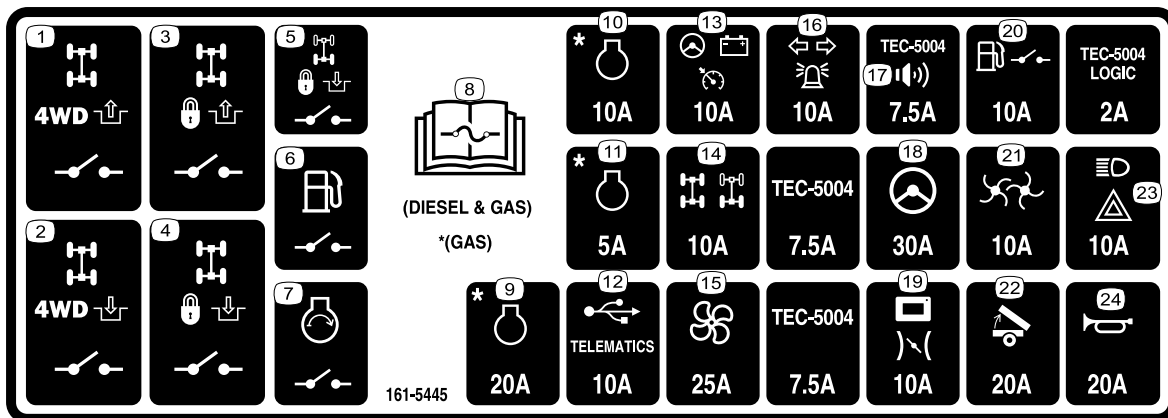

Figure 80

161-5445

decal161-5445

- | | | | |
|--|--|---|----------------------------------|
| 1. Front differential lock and 4-wheel drive disengage relay | 7. Starter relay | 13. Alternator, power steering, and speed sensor enable | 19. Display and throttle |
| 2. Front differential lock and 4-wheel drive engage relay | 8. Read the <i>Operator's Manual</i> for fuse information. | 14. Front and rear differentials | 20. Fuel-pump relay power |
| 3. Front differential lock disengage relay | 9. Engine ignition power | 15. Cooling fan | 21. Salt spreader |
| 4. Front differential lock engage relay | 10. Engine—ECM power | 16. Position lights and turn-signal lights | 22. Bed lift |
| 5. Rear differential lock engage relay | 11. Engine—vehicle-switch power | 17. Alarm | 23. Headlights and hazard lights |
| 6. Fuel-pump relay | 12. USB/telematics | 18. Power steering | 24. Horn |

Drive System Maintenance

Maintaining the Tires

Service Interval: Every 100 hours—Check the condition of the wheels and tires.

After the first 50 hours—Torque the wheel-lug nuts.

Every 250 hours—Torque the wheel-lug nuts.

1. Inspect the tires and rims for signs of wear and damage.

Note: Operating accidents, such as hitting curbs, can damage a tire or rim and also disrupt wheel alignment, so inspect tire condition after an accident.

2. Torque the wheel lug nuts to 108 to 122 N·m (80 to 90 ft-lb).

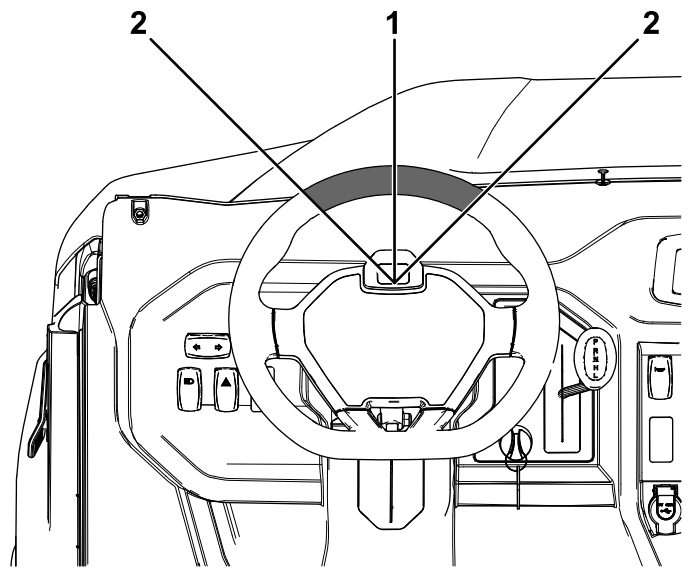

Figure 81

1. Steering wheel at the centered position
2. 13 mm (1/2 inch) from the center of the steering wheel

Checking the Steering and Suspension Components

Service Interval: Every 100 hours—Check the steering and suspension for loose or damaged components.

With the steering wheel at the centered position (Figure 81), turn the steering wheel to the left or right. If you turn the steering wheel more than 13 mm (1/2 inch) to the left or right, and the tires do not turn, check the following steering and suspension components to ensure that they are not loose or damaged:

- Steering shaft to the steering-rack assembly joint

Important: Check the condition and security of the pinion-shaft seal (Figure 82).

- Steering-rack assembly tie rods

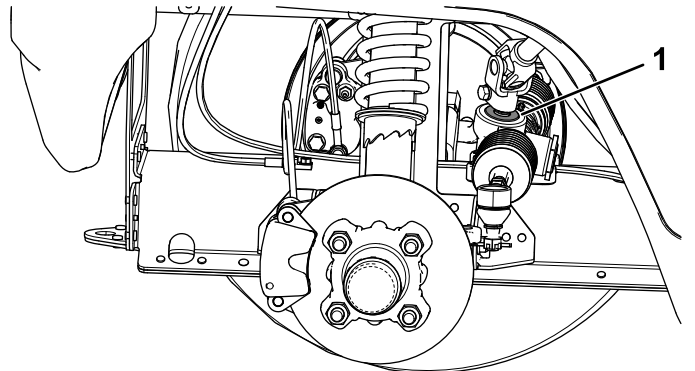

Figure 82

1. Pinion-shaft seal

Checking/Adjusting the Front Wheel Alignment

Service Interval: Every 100 hours/Yearly (whichever comes first)—Check the front wheel alignment.

Checking the Front Wheel Alignment

1. Check the tire pressure to ensure that the front tires are inflated properly; refer to [Checking the Tire Pressure \(page 39\)](#).
2. Either add weight to the driver's seat equal to the average operator who will run the machine, or have an operator sit on the seat. The weight or operator must remain on the seat for the duration of the adjustment procedure.
3. On a level surface, roll the machine straight back 2 to 3 m (6 to 10 ft) and then straight forward to the original starting position. This allows the suspension to settle into the operating position.
4. Ensure that the front tires are facing straight ahead.
5. Measure the distance between both of the front tires at the axle height at both the front and rear of the front tires ([Figure 83](#)).

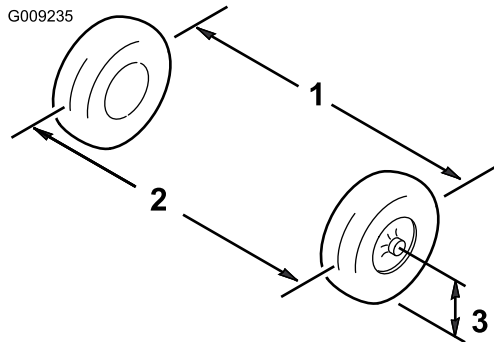

Figure 83

1. Tire center line—back
2. Tire center line—front
3. Axle center line

6. If the measurement is not within ± 6 mm ($\pm 1/4$ inch) from neutral (zero), proceed to [Adjusting the Front Wheel Alignment \(page 71\)](#).

Adjusting the Front Wheel Alignment

Important: Before adjusting the alignment, ensure that the height of the machine is as close to neutral as possible; refer to [Adjusting the Front Ride Height \(page 72\)](#).

1. Loosen the jam nuts at the outer end of the tie rods ([Figure 84](#)).
2. Rotate both tie rods to move the front of the tire inward or outward.
3. Tighten the tie rod jam nuts when the adjustment is correct.
4. Ensure that there is full travel of the steering wheel in both directions.

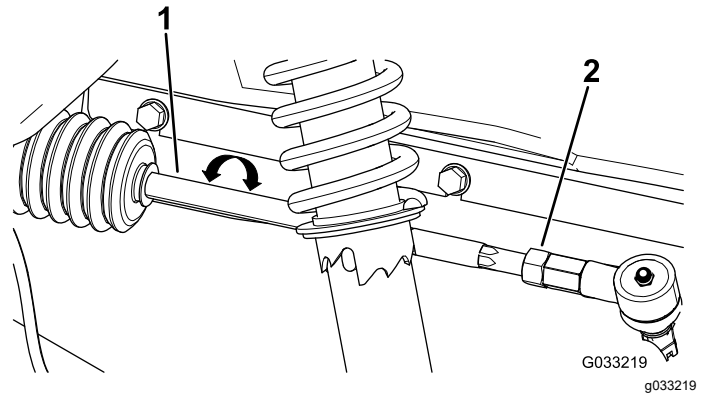

Figure 84

1. Tie rod
2. Jam nut

5. Check the measurement; refer to [Checking the Front Wheel Alignment \(page 71\)](#).

If the measurement is not within ± 6 mm ($\pm 1/4$ inch) from neutral (zero), repeat the steps for adjusting the front wheel alignment.

Adjusting the Front Ride Height

Owner-provided tools: spring-adjuster wrench, Toro Part 139-4678; refer to your authorized Toro distributor.

Important: Make height adjustments only if there is uneven tire wear or if you are adding additional weight to the front of the machine (e.g., adding a BOSS plow).

1. If you are adding weight to the front of the machine, adjust the ride height.

Check the tire pressure to ensure that the front tires are inflated properly; refer to [Maintaining the Tires \(page 70\)](#).

The ground clearance should be 23 cm (9 inches) for standard wheels and tires or 25 cm (10 inches) for the larger accessory wheels and tires.

2. If the ground clearance is not correct, use the spring-adjuster wrench to rotate the collar on the shock absorber to align the wheel ([Figure 85](#)).

Note: If the collar is difficult to rotate, raise the front of the machine; [Raising the Machine \(page 56\)](#).

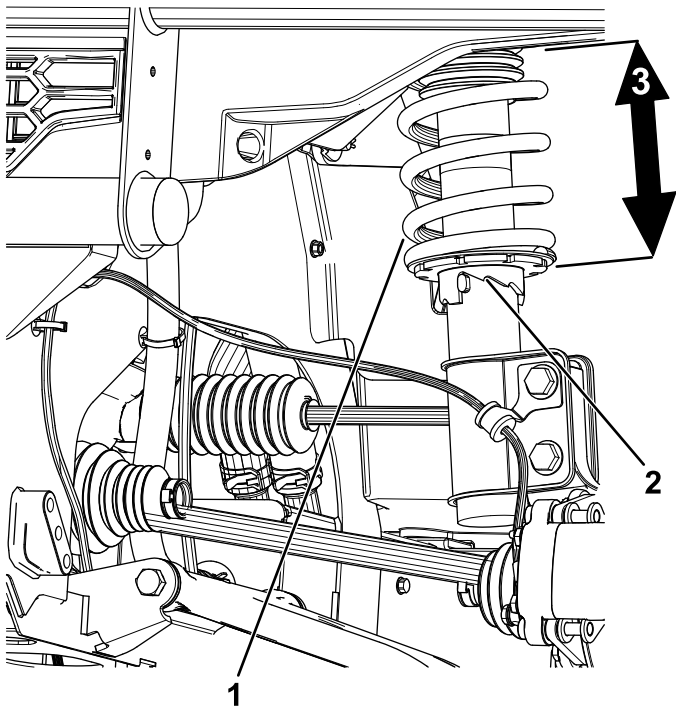

Figure 85

g364721

- | | |
|--------------------------|------------------|
| 1. Shock-absorber spring | 3. Spring length |
| 2. Collar | |

Checking the Transaxle-Fluid Level

Service Interval: Every 250 hours

Fluid Type: Toro Premium Synthetic Transaxle Fluid (Toro Part 145-2048)

1. Park the machine on a level surface.
2. Shift the transmission lever to the P (PARK) position.
3. Shut off the engine and remove the key.
4. Remove the fill plug on the transaxle (Figure 86).

Note: The fluid level should be even with the bottom of the fill plug.

5. If the fluid level is low, remove the fill plug and add the specified fluid until it runs out of the hole (Figure 86).
6. Replace the fill plug and torque it to 14 to 30 N·m (10 to 22 ft-lb).

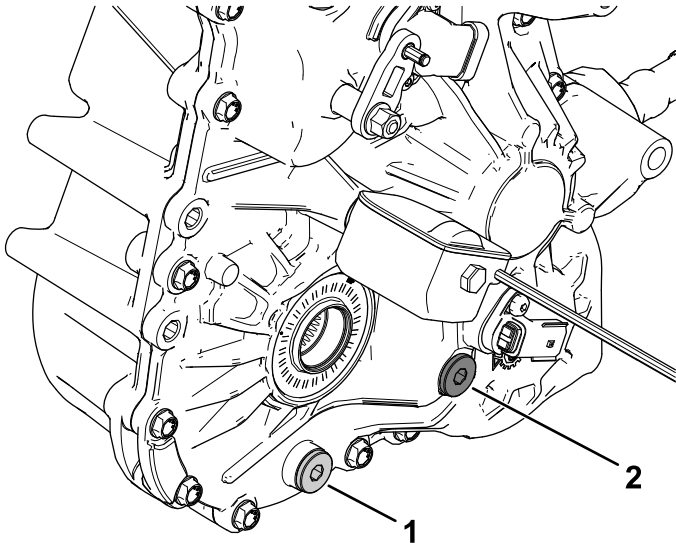

Figure 86

g362542

1. Drain plug

2. Fill plug

Changing the Transaxle Fluid

Service Interval: Every 500 hours

Fluid Type: Toro Premium Synthetic Transaxle Fluid (Toro Part 145-2048)

Fluid Capacity: 1.21 L (41 fl oz)

1. Align a drain pan under the drain plug (Figure 86).
2. Remove the fill plug (Figure 86).

Note: Retain the fill plug and seal for installation in step 6.

3. Remove the drain plug, and allow the fluid to drain completely (Figure 86).

Note: Retain the drain plug for installation in step 4.

4. Install the drain plug and torque it to 14 to 30 N·m (10 to 22 ft-lb).
5. Fill the transaxle with the specified fluid and capacity until it is even with the fill hole.
6. Install the fill plug and torque it to 14 to 30 N·m (10 to 22 ft-lb).

Checking the Front Differential Oil Level

Service Interval: Every 500 hours—Check the front differential oil level.

Fluid Type: 80W-90 Gear Oil

1. Park the machine on a level surface.
2. Shift the transmission lever to the P (PARK) position.
3. Shut off the engine and remove the key.
4. Remove the check plug on the front differential (Figure 87).

Note: The oil level should be even with the bottom of the check plug.

5. If the oil level is low, you may add the specified oil through the check plug opening (Figure 87).
6. Replace the check plug and torque it to 15 to 25 N·m (11 to 18 ft-lb).

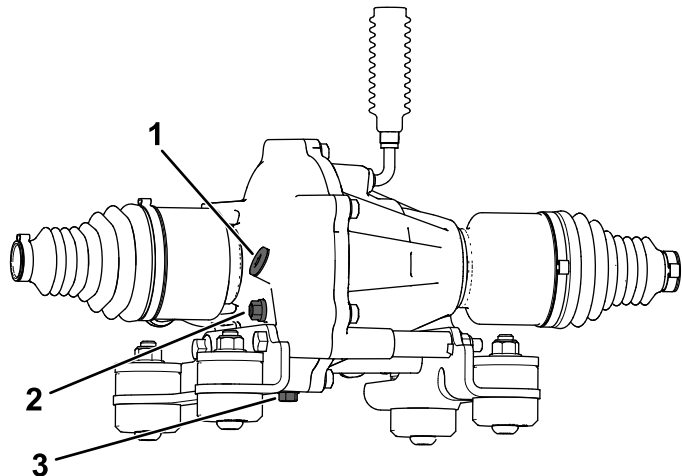

Figure 87

g399038

1. Fill plug
2. Check plug
3. Drain plug

Changing the Front Differential Oil

Service Interval: Every 1,000 hours—Change the front differential oil.

Fluid Type: 80W-90 Gear Oil

Fluid Capacity: 0.15 L (5 fl oz)

1. Park the machine on a level surface.
2. Shift the transmission lever to the P (PARK) position.
3. Shut off the engine and remove the key.
4. Align a drain pan under the drain plug (Figure 87).

5. Remove the fill plug (Figure 87).

Note: Retain the fill plug and seal for installation in step 9.

6. Remove the drain plug and allow the fluid to drain completely (Figure 87).

Note: Retain the drain plug for installation in step 7.

7. Install the drain plug and torque it to 15 to 25 N·m (11 to 18 ft-lb).
8. Fill the front differential with the specified fluid and capacity.
9. Install the fill plug and torque it to 15 to 25 N·m (11 to 18 ft-lb).
10. Allow the oil to settle for approximately 5 minutes, then check the level; [Checking the Front Differential Oil Level \(page 74\)](#).

Cooling System Maintenance

Cooling System Safety

- Swallowing engine coolant can cause poisoning; keep out of reach from children and pets.
- Discharge of hot, pressurized coolant or touching a hot radiator and surrounding parts can cause severe burns.
 - Always allow the engine to cool at least 15 minutes before removing the radiator cap.
 - Use a rag when opening the radiator cap, and open the cap slowly to allow steam to escape.
- Do not operate the machine without the covers in place.
- Keep your fingers, hands and clothing clear of rotating fan and drive belt.
- Shut off the engine and remove the key before performing maintenance.

Checking the Engine-Coolant Level

Service Interval: Before each use or daily—Check the level of the coolant.

Coolant type: 50% ethylene-glycol with organic additive technology (OAT) 50% distiller water

⚠ WARNING

If the engine has been running, the pressurized, hot coolant can escape and cause burns.

- Do not open the radiator cap when the engine is running.
- Use a rag when opening the radiator cap, and open the cap slowly to allow steam to escape.

Removing Debris from the Cooling System

Service Interval: Before each use or daily—Remove debris from the engine area and radiator.

1. Park the machine on a level surface.
2. Shift the transmission lever to the P (PARK) position.
3. Shut off the engine and remove the key.
4. Clean the engine area thoroughly of all debris.
5. Remove the 7 screws securing the grill and remove the grill (Figure 89).

1. Park the machine on a level surface.
2. Shift the transmission lever to the P (PARK) position.
3. Shut off the engine and remove the key.
4. Check the coolant level in the coolant tank (Figure 88).

Note: The fill level depends on the coolant temperature.

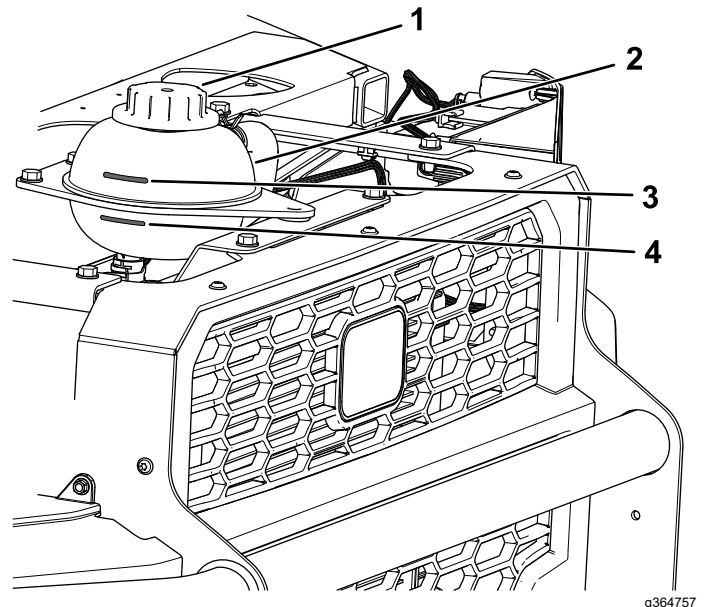

Figure 88

1. Coolant-tank cap
2. Coolant tank
3. Fill level when the coolant is hot
4. Fill level when the coolant is cold

5. If coolant is low, remove the coolant-tank cap and add a 50% ethylene-glycol with organic additive technology (OAT) 50% distiller water antifreeze.

Do not overfill.

6. Hand-tighten the coolant-tank cap until you hear it click.

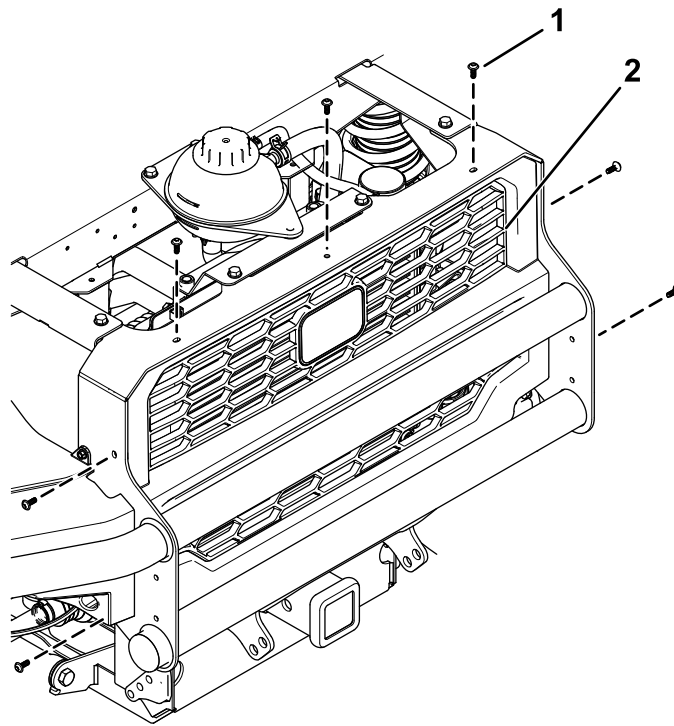

g365212

Figure 89

1. Screw

2. Grill

6. Clean the radiator assembly using compressed air.

Note: Blow debris away from the radiator.

7. Install the grill using the previously removed 7 screws ([Figure 89](#)).

Checking the Coolant Hoses

Service Interval: Every 500 hours

Check the coolant hoses for cracks, swelling, or deterioration.

Replace the hoses if there are cracks, swelling, or deterioration.

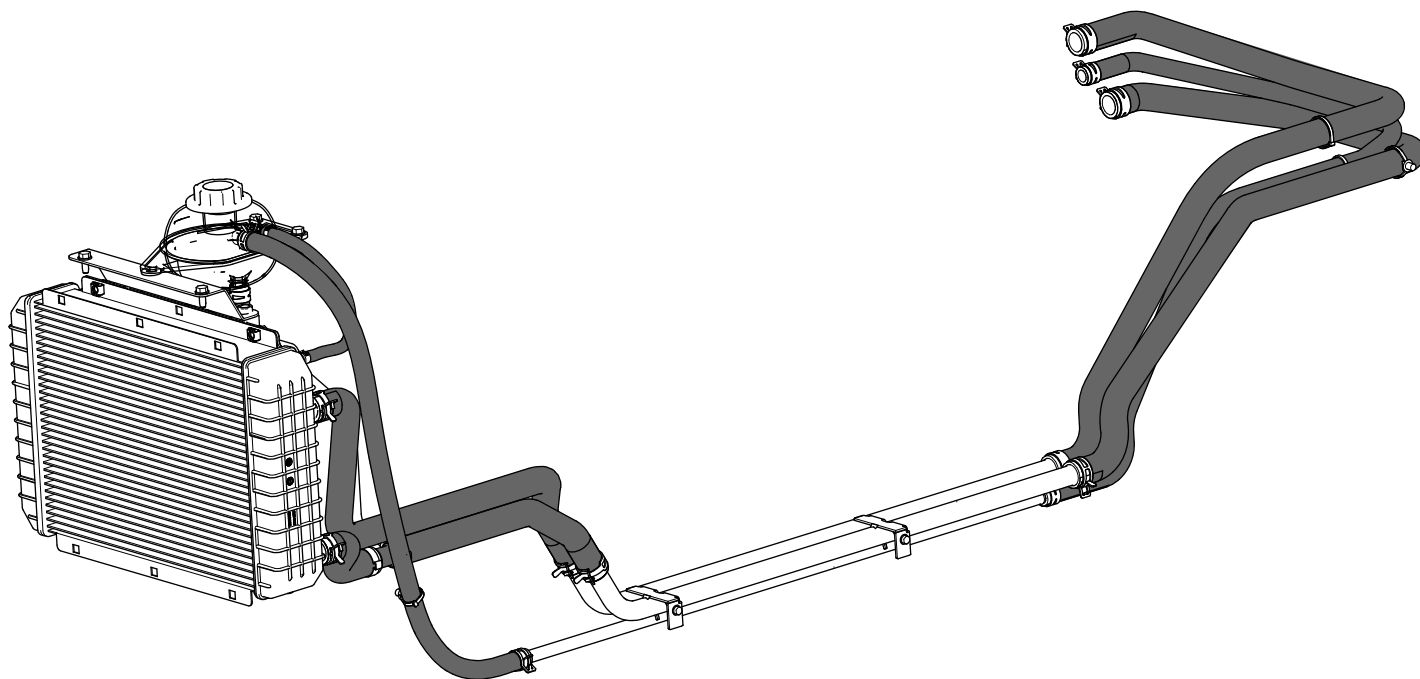

Figure 90

g401265

Changing the Engine Coolant

Service Interval: Every 1,000 hours/Every 5 years (whichever comes first)—Change the engine coolant.

Contact your authorized Toro distributor.

Brake Maintenance

Checking the Brakes

Service Interval: Every 100 hours

⚠ CAUTION

After operating the machine, the brake components may be hot. Touching hot brake components may burn you.

Before checking the brakes, wait for the brake components to cool down.

Important: Brakes are a critical safety component of the machine. Closely inspect them at the recommended service interval to ensure optimum performance and safety.

- Check the brake lining for wear or damage. If the lining (brake pad) thickness is less than 1.6 mm (1/16 inch), replace the brake lining.
- Check the backing plate and other components for signs of excessive wear or deformation. Replace any deformed components.
- Check the brake-fluid level; refer to [Checking the Brake-Fluid Level](#) (page 78).

Checking the Brake-Fluid Level

Service Interval: Before each use or daily—Check the brake-fluid level. Check the brake-fluid level before you start the engine.

Brake-fluid type: DOT 3

1. Park the machine on a level surface.
2. Shift the transmission lever to the P (PARK) position.
3. Shut off the engine and remove the key.
4. Raise the hood to access to the master brake cylinder and reservoir (Figure 91).

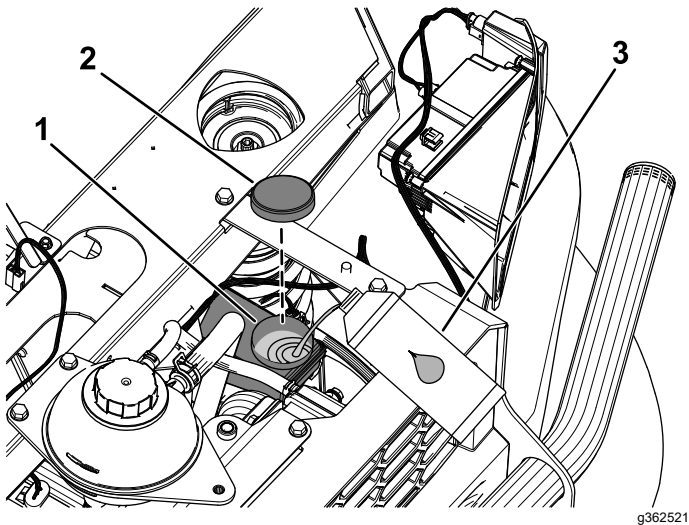

Figure 91

1. Filler neck (reservoir)
2. Reservoir cap
3. DOT 3 brake fluid

5. Look at the outline of the fluid level at the side of the reservoir (Figure 92).

Note: The level should be above the Minimum line.

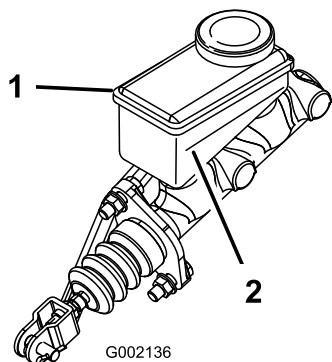

Figure 92

1. Brake-fluid reservoir
2. Minimum line

6. If the fluid level is low, perform the following:
 - A. Clean the area around the reservoir cap and remove the cap (Figure 91).
 - B. Add DOT 3 brake fluid to the reservoir until the fluid level is above the Minimum line (Figure 92).

Note: Do not overfill the reservoir with brake fluid.

 - C. Install the reservoir cap (Figure 91).
7. Close the hood.

Changing the Brake Fluid

Service Interval: Every 1,000 hours/Every 5 years (whichever comes first)—Change the brake fluid.

Contact your authorized Toro distributor.

Belt Maintenance

Servicing the Drive Belt

Checking the Drive Belt and Cleaning the Clutches

Service Interval: Every 250 hours

1. Park the machine on a level surface.
2. Shift the transmission lever to the P (PARK) position.
3. Shut off the engine and remove the key.
4. Raise the cargo bed.
5. Unlatch the 6 spring clips securing the belt cover and remove the cover ([Figure 93](#)).

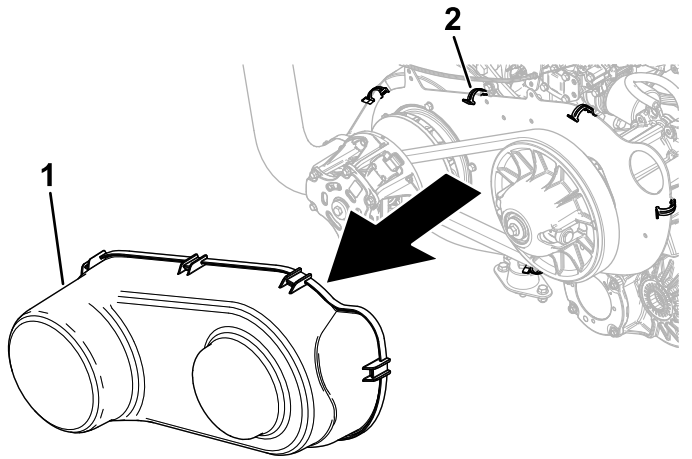

Figure 93

1. Belt cover
2. Spring clip

6. Rotate and inspect the belt ([Figure 94](#)) for signs of excessive wear or damage.

Note: Replace the belt if it is excessively worn or damaged; refer to [Replacing the Drive Belt \(page 79\)](#).

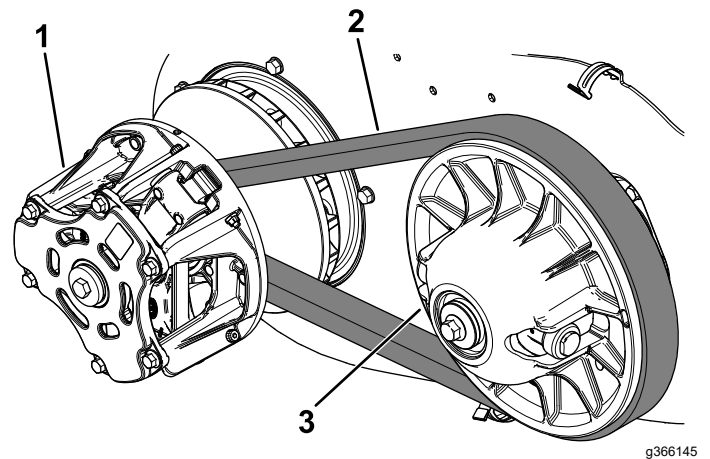

Figure 94

1. Primary clutch
2. Drive belt
3. Secondary clutch

7. Using compressed air, clean the clutches thoroughly of all debris ([Figure 94](#)).
8. Install the belt cover ([Figure 93](#)).
9. Lower the cargo bed.

Replacing the Drive Belt

Service Interval: Every 500 hours—Replace the drive belt.

1. Park the machine on a level surface.
2. Shift the transmission lever to the P (PARK) position.
3. Shut off the engine and remove the key.
4. Raise the cargo bed.
5. Unlatch the 6 spring clips securing the belt cover and remove the cover ([Figure 93](#)).
6. Pull up on the top of the belt to spread out the secondary clutch, then rotate and route the belt over the secondary clutch ([Figure 94](#)).
7. Remove the belt from the primary clutch ([Figure 94](#)).

Note: Discard the old belt.

8. Align the new belt over the primary clutch ([Figure 94](#)).
9. Rotate and route the belt over the secondary clutch ([Figure 94](#)).
10. Install the belt cover ([Figure 93](#)).
11. Lower the cargo bed.

Cleaning

Washing the Machine

Wash the machine as needed using water alone or with a mild detergent. You may use a rag when washing the machine.

Important: Do not use brackish or reclaimed water to clean the machine.

Important: Do not use power-washing equipment to wash the machine. Power-washing equipment may damage the electrical system, loosen important decals, or wash away necessary grease at friction points. Avoid excessive use of water near the control panel, engine, and battery.

Important: Do not wash the machine with the engine running. Washing the machine with the engine running may result in internal engine damage.

Storage

Storage Safety

- Shut off the engine, remove the key, and wait for all movement to stop before you leave the operator's position. Allow the machine to cool before adjusting, servicing, cleaning, or storing it.
- Do not store the machine or fuel container where there is an open flame, spark, or pilot light, such as on a water heater or other appliance.

Storing the Machine

1. Position the machine on a level surface, shift the transmission lever to the P (PARK) position, shut off the engine, and remove the key from the key switch.
2. Clean dirt and grime from the entire machine, including the engine area

Important: You can wash the machine with mild detergent and water. Do not use high-pressure water to wash the machine. Pressure washing the machine may damage the electrical system or wash away necessary grease at friction points. Avoid excessive use of water, especially near the control panel, lights, engine, and battery.

3. Service the air cleaner; refer to [Servicing the Air Cleaner \(page 60\)](#).
4. Grease the machine; refer to [Greasing the Machine \(page 58\)](#).
5. Change the engine oil and filter; refer to [Changing the Engine Oil and Filter \(page 62\)](#).
6. Check the tire pressure; refer to [Checking the Tire Pressure \(page 39\)](#).
7. For long-term storage (3 months or more), prepare the fuel system as follows:
 - A. Add a petroleum based stabilizer/conditioner to the fuel in the tank. Do not use an alcohol-based stabilizer (ethanol or methanol).

Important: Do not store fuel containing stabilizer/conditioner longer than the duration recommended by the fuel stabilizer manufacturer.

- B. Run the engine to distribute conditioned fuel through the fuel system for 5 minutes.
- C. Shut off the engine, allow it to cool, and drain the fuel tank.
- D. Start the engine and run it until it stops.

- E. Start and run the engine again until it does not start again.
 - F. Dispose of drained fuel properly. Recycle as per local codes.
8. Check the anti freeze protection and add a 50/50 solution of water and anti freeze as needed for expected minimum temperature in your area.
 9. Remove the battery from the chassis, and charge it fully; refer to [Removing the Battery \(page 67\)](#).

Note: Do not connect the battery cables to the battery posts during storage.

Important: The battery must be fully charged to prevent it from freezing and being damaged at temperatures below 0°C (32°F). A fully charged battery maintains its charge for about 50 days at temperatures lower than 4°C (40°F). If the temperatures will be above 4°C (40°F), check the water level in the battery and charge it every 30 days.

10. Check and tighten all fasteners. Repair or replace any part that is damaged.
11. Paint all scratched or bare metal surfaces with paint available from your authorized Toro distributor.
12. Store the machine in a clean, dry garage or storage area.
13. Remove the key from the key switch and put it in a safe place that is out of the reach of children.
14. Cover the machine to protect it and keep it clean.

Troubleshooting

Problem	Possible Cause	Corrective Action
The engine does not crank over.	<ol style="list-style-type: none"> 1. Your foot is not on the brake pedal. 2. The battery is dead and/or there is a bad battery connection. 	<ol style="list-style-type: none"> 1. Put your foot on the brake pedal. 2. Check the battery connections. If the battery is dead, replace the battery.
The engine cranks, but does not start.	<ol style="list-style-type: none"> 1. The fuel tank is empty. 2. There is dirt, water, or stale fuel in the fuel system. 3. The air cleaner is dirty or plugged. 	<ol style="list-style-type: none"> 1. Fill the fuel tank. 2. Contact your authorized Toro distributor. 3. Clean or replace the air cleaner.
The power steering moves hard.	<ol style="list-style-type: none"> 1. There is a blown fuse in the electrical system. 2. The power steering controller is disconnected. 3. The power steering motor and/or controller is bad. 	<ol style="list-style-type: none"> 1. Inspect and replace the fuse. 2. Connect the power steering controller. 3. Replace the power steering motor and/or controller; contact your authorized Toro distributor.
The throttle is not responding.	<ol style="list-style-type: none"> 1. The transmission lever is in the P (PARK) position, N (NEUTRAL) position, or between gears. 2. The "no seat belt" feature is set to 0 km/h or mph. 3. The gear position sensor is non-functional or damaged. 	<ol style="list-style-type: none"> 1. Shift the transmission lever into a drive position. 2. Secure your seat belt. 3. Contact your authorized Toro distributor.
The 4-wheel drive/differential locks are not working.	<ol style="list-style-type: none"> 1. There is a blown fuse in the electrical system. 2. The feature was disabled during software setup. 3. The switches and/or differential(s) are unplugged. 4. The actuator/solenoid is bad. 	<ol style="list-style-type: none"> 1. Inspect and replace the fuse. 2. Contact your authorized Toro distributor. 3. Inspect and reconnect the harness. 4. Contact your authorized Toro distributor.
The cruise control feature does not engage.	<ol style="list-style-type: none"> 1. Your seat belt is not secured. 2. You are not traveling at the minimum machine speed. 	<ol style="list-style-type: none"> 1. Secure your seat belt. 2. Increase the machine speed to set the cruise control.
The clutch engagement is abrupt.	<ol style="list-style-type: none"> 1. The belt is new. 2. The clutches are dirty. 	<ol style="list-style-type: none"> 1. Allow 10 hours of normal operation for the belt break-in period. 2. Clean the clutches.
The acceleration seems too slow when the engine is at maximum speed (rpm).	<ol style="list-style-type: none"> 1. The belt is slipping and/or damaged. 2. The clutches are dirty. 	<ol style="list-style-type: none"> 1. Check the belt; replace, if needed. 2. Clean the clutches.
The battery is not charging.	<ol style="list-style-type: none"> 1. The engine belt is loose and/or damaged. 2. There is a bad electrical connection to the alternator. 3. The alternator is bad. 4. The battery is dead and/or there is a bad battery connection. 	<ol style="list-style-type: none"> 1. Check the belt; replace, if needed. 2. Check the harness connection. 3. Contact your authorized Toro distributor. 4. Check the battery connections. If the battery is dead, replace the battery.

Problem	Possible Cause	Corrective Action
The tachometer on the display is sporadic/inconsistent.	<ol style="list-style-type: none"> 1. The engine belt is loose and/or damaged. 2. There is a bad electrical connection to the alternator. 3. The alternator is bad. 	<ol style="list-style-type: none"> 1. Check the belt; replace, if needed. 2. Check the harness connection. 3. Contact your authorized Toro distributor.
The engine does not reach maximum rpm while driving.	<ol style="list-style-type: none"> 1. The cable is stretched and/or the assembly in the system has settled. 	<ol style="list-style-type: none"> 1. Perform the throttle calibration procedure.

Machine Fault Codes

Problem	Possible Cause	Corrective Action
A fault code appears on the display.	<ol style="list-style-type: none"> 1. There is an issue with the machine. 	<ol style="list-style-type: none"> 1. Do not operate the machine if a fault code appears; otherwise, serious damage could occur. Contact your authorized Toro distributor.

California Proposition 65 Warning Information

What is this warning?

You may see a product for sale that has a warning label like the following:



WARNING: Cancer and Reproductive Harm—www.p65Warnings.ca.gov.

What is Prop 65?

Prop 65 applies to any company operating in California, selling products in California, or manufacturing products that may be sold in or brought into California. It mandates that the Governor of California maintain and publish a list of chemicals known to cause cancer, birth defects, and/or other reproductive harm. The list, which is updated annually, includes hundreds of chemicals found in many everyday items. The purpose of Prop 65 is to inform the public about exposure to these chemicals.

Prop 65 does not ban the sale of products containing these chemicals but instead requires warnings on any product, product packaging, or literature with the product. Moreover, a Prop 65 warning does not mean that a product is in violation of any product safety standards or requirements. In fact, the California government has clarified that a Prop 65 warning "is not the same as a regulatory decision that a product is 'safe' or 'unsafe.'" Many of these chemicals have been used in everyday products for years without documented harm. For more information, go to <https://oag.ca.gov/prop65/faqs-view-all>.

A Prop 65 warning means that a company has either (1) evaluated the exposure and has concluded that it exceeds the "no significant risk level"; or (2) has chosen to provide a warning based on its understanding about the presence of a listed chemical without attempting to evaluate the exposure.

Does this law apply everywhere?

Prop 65 warnings are required under California law only. These warnings are seen throughout California in a wide range of settings, including but not limited to restaurants, grocery stores, hotels, schools, and hospitals, and on a wide variety of products. Additionally, some online and mail order retailers provide Prop 65 warnings on their websites or in catalogs.

How do the California warnings compare to federal limits?

Prop 65 standards are often more stringent than federal and international standards. There are various substances that require a Prop 65 warning at levels that are far lower than federal action limits. For example, the Prop 65 standard for warnings for lead is 0.5 µg/day, which is well below the federal and international standards.

Why don't all similar products carry the warning?

- Products sold in California require Prop 65 labelling while similar products sold elsewhere do not.
- A company involved in a Prop 65 lawsuit reaching a settlement may be required to use Prop 65 warnings for its products, but other companies making similar products may have no such requirement.
- The enforcement of Prop 65 is inconsistent.
- Companies may elect not to provide warnings because they conclude that they are not required to do so under Prop 65; a lack of warnings for a product does not mean that the product is free of listed chemicals at similar levels.

Why does Toro include this warning?

Toro has chosen to provide consumers with as much information as possible so that they can make informed decisions about the products they buy and use. Toro provides warnings in certain cases based on its knowledge of the presence of one or more listed chemicals without evaluating the level of exposure, as not all the listed chemicals provide exposure limit requirements. While the exposure from Toro products may be negligible or well within the "no significant risk" range, out of an abundance of caution, Toro has elected to provide the Prop 65 warnings. Moreover, if Toro does not provide these warnings, it could be sued by the State of California or by private parties seeking to enforce Prop 65 and subject to substantial penalties.