



Z588E Z Master[®] With 72in TURBO FORCE Side Discharge Mower

Model No. 74256 - 240000001 and up.

Parts Catalog

Ordering Replacement Parts

To order replacement parts, please supply the part number, the quantity, and the description of each part desired.

Understanding Reference Numbers

Each Identified part in an illustration has a reference number. The reference number for a part also appears in the parts list, along with other information about the part.

This catalog uses two special reference number formats, one to indicate parts in a service assembly and another to indicate the quantity of a given part in an illustration.

Service Assembly Reference Numbers

Parts in service assemblies have reference numbers in the form a:b. The a represents the reference number of the entire service assembly and the b represents a sequential number unique to each part within the service assembly.

For example, a wheel assembly might be identified by reference number 6, the tire by 6:1, the valve by 6:2, and the wheel by 6:3. When you order the assembly identified by reference number 6, you receive all parts identified by reference numbers 6:1, 6:2, and 6:3. However, you may also order any part individually. Reference numbers of this type appear in illustrations and in part lists.

Reference Numbers Indicating Quantity

In an illustration, if a reference number indicates more than one part, the reference number has the form nX y. The n represents the quantity of the part, the X is the multiplication symbol, and the y represents the reference number.

For example, in an illustration, the reference number 2X 37 means that two of the parts identified by reference number 37 are indicated.

Contents

Description	Page	Description	Page
Front Frame Assembly 3	Deck and Decal Assembly No. 107-1625 25
Castor and Wheel Assembly 5	Rubber Deflector Assembly No. 106-3249 26
Main Frame Assembly 6	Lever Assembly No. 106-3242 27
Brake and Wheel Hub Assembly 7	Crankshaft Assembly Kohler CH745-0003 28
Steering Control Assembly 8	Crankcase Assembly Kohler CH745-0003 29
Hydraulic System Assembly 9	Oil Pan/Lubrication Assembly Kohler CH745-0003 30
Seat and Roll-Over-Protection System Assembly 11	Head/Valve/Breather Assembly Kohler CH745-0003 31
Suspension Seat Assembly No. 106-9988 12	Ignition/Electrical Assembly Kohler CH745-0003 32
Roll-Over-Protection System Assembly No. 107-0038 13	Blower Housing and Baffle Assembly Kohler CH745-0003 33
Deck Mounting Assembly 14	Starting System Assembly Kohler CH745-0003 34
Drive Idler Assembly 15	Fuel System Assembly Kohler CH745-0003 35
Z-Stand Assembly 16	Engine Control Assembly Kohler CH745-0003 36
Engine and Clutch Assembly 17	Air Intake/Filtration Assembly Kohler CH745-0003 37
Muffler and Guard Assembly 18	Exhaust Assembly Kohler CH745-0003 38
Fuel Assembly 19		
Electrical Assembly 21		
72 Inch Deck Assembly 23		
Spindle Assembly No. 106-3217 24		

Footnotes

- ❶ Not illustrated
- ❷ X-22-11-S washer used with M-561016-S screw to ground ignition coil lead.
- ❸ Not serviced separately
- ❹ Obtain Parts From Your Local Kohler Dealer

Part Description Abbreviations

Part descriptions in this catalog may include the following abbreviations.

AR.	as required	HWHTF.	hex washer head thread forming
ASM.	assembly	HYD.	hydraulic
CARR.	carriage	INC.	incorporated
DEG.	degrees	LH.	left hand
FH.	flat head	NI.	nylon insert
GA.	gauge	PPH.	phillips pan head
HF.	hex flange	PTH.	phillips truss head
HH.	hex head	PTO.	power take off
HHF.	hex head flange	RH.	right hand
HHFTF.	hex head flange thread forming	SFH.	slotted fillister head
HJ.	hex jam	SHH.	slotted hex head
HLH.	hex lag head	SHWH.	slotted hex washer head
HOC.	height-of-cut	SPH.	slotted pan head
HS.	hex	SQH.	square head
HSBH.	hex socket button head	SRH.	slotted round head
HSFH.	hex socket flat head	STD.	standard
HSH.	hex socket head	TAP.	self tapping
HWH.	hex washer head	TTH.	torx truss head

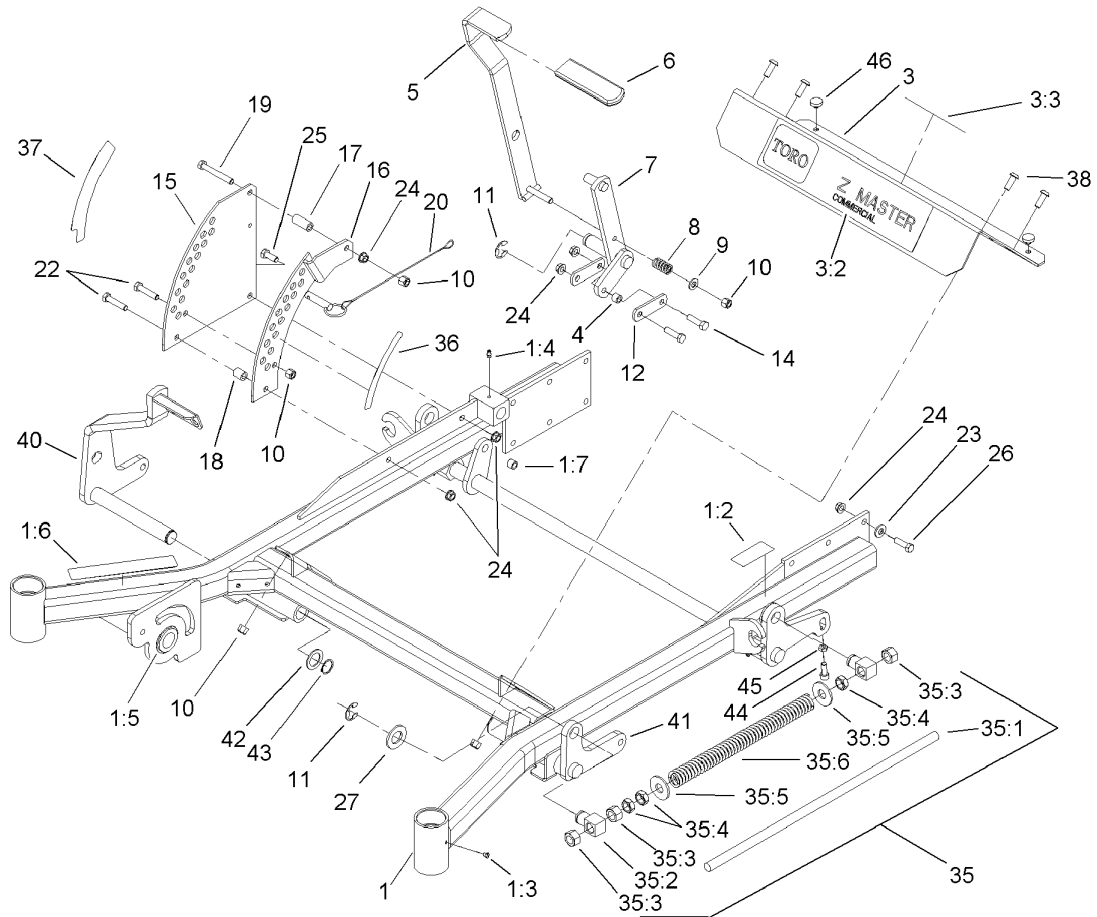

Front Frame Assembly

Ref	Part No.	Qty.	Description
1	106-8999	1	Frame ASM
1:2	107-1857	1	Decal-Brake, Parking
1:3	1-811010	2	Plug
1:4	302-19	5	Fitting-Grease
1:5	94-1291	2	Bushing
1:6	104-7759	1	Decal-Warning
1:7	103-1918	1	Bushing
3	106-9981	1	Front Floorpan ASM
3:2	106-7451	1	Decal
3:3	107-2112	1	Decal-Warning
4	103-1918	1	Bushing
5	103-2083-03	1	Lever-Lift
6	1-633295	1	Grip-Lever, Lift
7	103-2064-03	1	Arm-Lift, Deck
8	1-633325	1	Spring-Compression
9	3256-24	1	Washer-Flat
10	3296-39	9	Nut-Lock, NI
11	32151-103	5	Ring-Snap
12	1-633068	2	Arm-Lift, Deck
14	323-29	2	Screw-HH
15	1-633889-01	1	Plate-Lift, Deck
16	1-632899-01	1	Plate-Lift, Deck
17	1-633082	1	Bushing-Lever, Lift
18	1-633080	1	Bushing-Lever, Lift

Ref	Part No.	Qty.	Description
19	323-13	1	Screw-HH
20	106-9951	1	Hitch Pin ASM
22	323-9	2	Screw-HH
23	98-5975	12	Washer-Belleville
24	3290-357	15	Nut-HHF
25	323-6	1	Screw-HH
26	323-7	12	Screw-HH
27	3256-29	4	Washer-Flat
35		2	Front Frame Spring ASM
35:1	1-633096	1	Rod-Lift, Deck
35:2	1-633441	2	Swivel-Deck Mount, Rear
35:3	3217-11	3	Nut-Hex
35:4	3218-6	3	Nut-Jam
35:5	3256-7	2	Washer-Flat
35:6	1-643015	1	Spring-Support, Deck
36	107-1861	1	Decal-Height, Deck
37	107-1860	1	Decal-Height, Deck
38	3274-94	4	Screw-HSBH
40	106-8983-01	1	RH Deck Lift ASM
41	106-8984-01	1	LH Deck Lift ASM
42	1-523157	2	Washer-Spacer
43	32151-29	2	Ring-Retaining
44	3274-18	2	Screw-HSH
45	3218-2	2	Nut-Jam

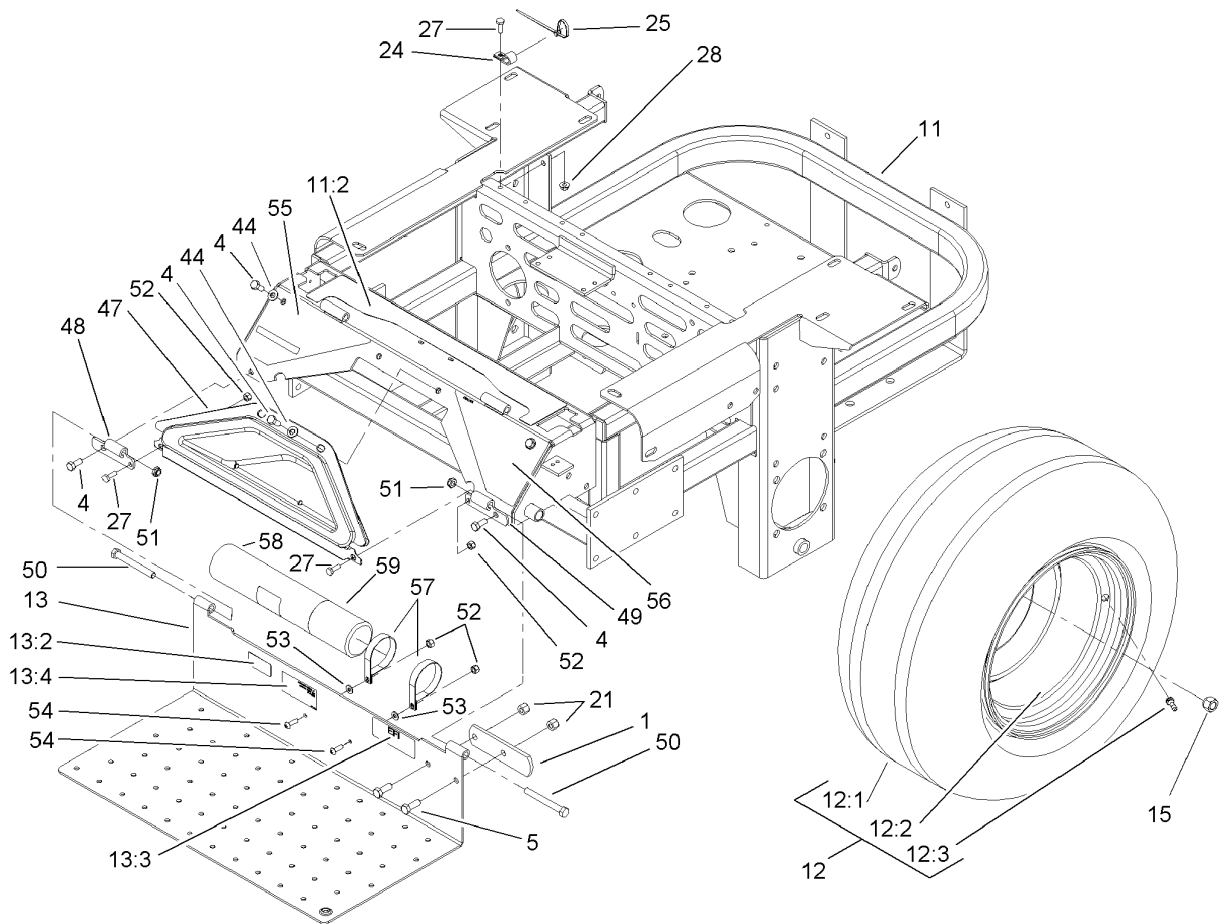

Main Frame Assembly

Ref	Part No.	Qty.	Description
1	1-633964-03	1	Stop-Brake, Park
4	322-43	6	Screw-HH
5	323-6	2	Screw-HH
11	106-6599	1	Main Frame ASM
11:2	103-2433	1	Decal-Console, Top
12	1-633970	2	Wheel And Tire ASM
12:1	1-633993	1	Tire
12:2	1-633992	1	Wheel
12:3	232-27	1	Stem-Valve
13	107-1859	1	Floorpan
13:2	106-7486	1	Decal-Efi
13:3	98-4387	1	Decal-Protection, Ear
13:4	107-1864	1	Decal-Location, Manual
15	242-50	8	Nut-Lug
21	3296-39	2	Nut-Lock, NI
24	1-513762	1	Clip-Loom
25	1-303335	1	Tie-Plastic
27	321-4	3	Screw-HH
28	32128-33	1	Nut-HF
44	3256-70	6	Washer-Flat
47	106-7498	1	Pocket
48	106-7488-03	1	Hinge-Floorpan, LH
49	106-7489-03	1	Hinge-Floorpan, RH
50	323-20	2	Screw-HH

Ref	Part No.	Qty.	Description
51	3296-59	2	Nut-Lock, NI
52	3296-42	4	Nut-Lock, NI
53	3256-63	2	Washer-Flat
54	3258-166	2	Screw
55	106-9989	1	Decal-Warning
56	106-7492	1	Decal-Danger
57	107-1865	2	R-Clamp
58	104-7050	1	Housing-Manual
59	104-7048	1	Cap-Housing

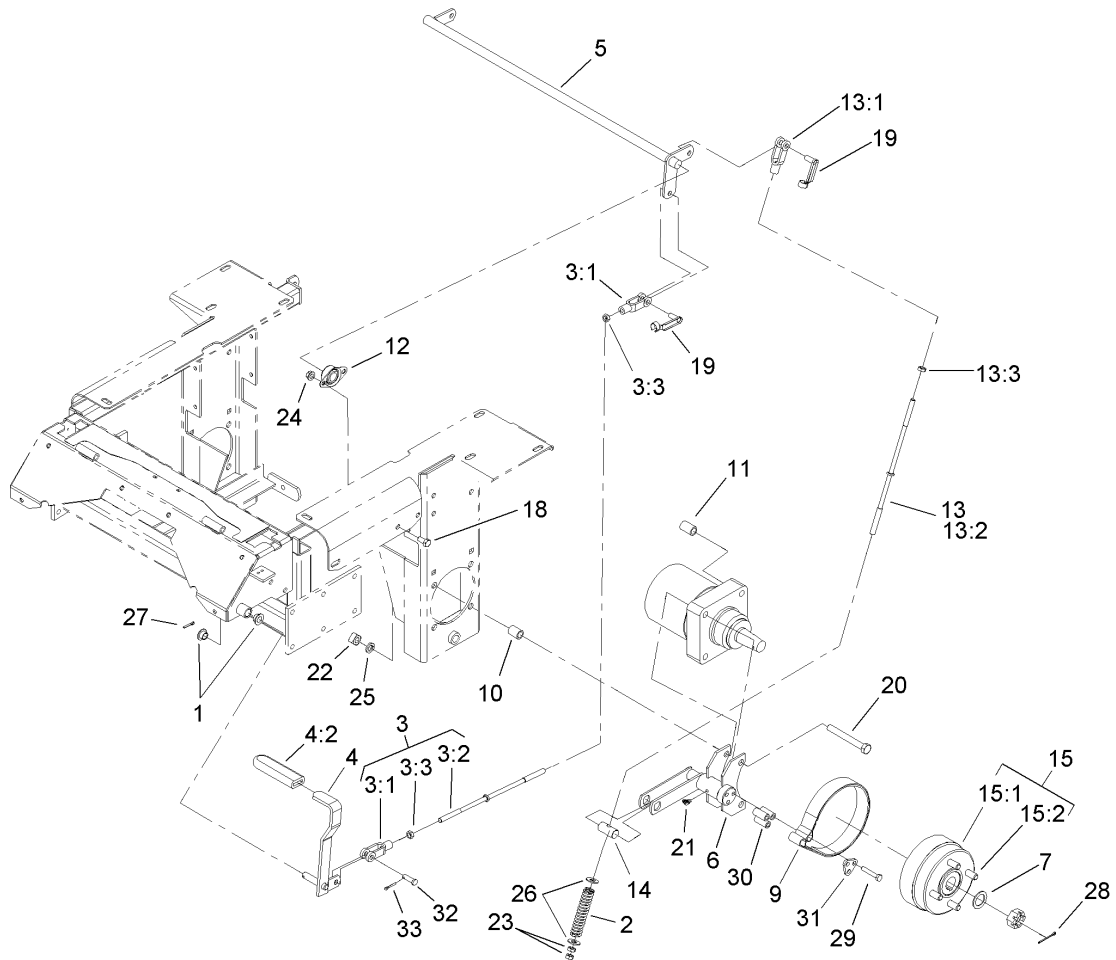

Brake and Wheel Hub Assembly

Ref	Part No.	Qty.	Description
1	1-513140	2	Bearing-Control
2	1-633454	2	Spring-Brake
3	103-4332	1	Brake Rod And Yoke ASM
3:1	1-633131	2	Yoke-Linkage, Brake
3:2	1-633477	1	Rod-Brake
3:3	3219-3	2	Nut-HH
4	1-634500	1	Brake Lever ASM
4:2	1-633268	1	Grip-Lever, Brake
5	1-632217-03	1	Shaft-Brake
6	103-0354-03	2	Bracket-Brake
7	1-523157	2	Washer-Spacer
9	103-0355	2	Band-Brake
10	1-633060	4	Spacer-Wheel, Short
11	1-633062	4	Spacer-Wheel, Long
12	1-633102	2	Bearing-Flange, Side
13	103-4333	2	Brake Rod And Yoke ASM
13:1	1-633131	1	Yoke-Linkage, Brake
13:2	1-633477	1	Rod-Brake
13:3	3219-3	1	Nut-HH
14	1-633144	2	Pin-Trunion
15	103-0590	2	Hub And Wheel ASM
15:1	103-0589	1	Wheel Hub ASM
15:2	1-633926	4	Stud-Wheel
18	323-4	4	Screw-HH

Ref	Part No.	Qty.	Description
19	103-2399	3	Pin-Spring, Clevis
20	325-20	8	Screw-HH
21	302-19	2	Fitting-Grease
22	103-0131	8	Nut-Square
23	3219-3	4	Nut-HH
24	3290-357	4	Nut-HHF
25	3253-7	8	Washer-Lock
26	3256-4	4	Washer-Flat
27	3272-10	1	Pin-Cotter
28	1-806800	2	Pin-Cotter
29	322-9	6	Screw-HH
30	103-0384	6	Spacer
31	103-0374	2	Retainer-Band, Brake
32	1-808285	1	Pin-Clevis
33	3272-10	1	Pin-Cotter

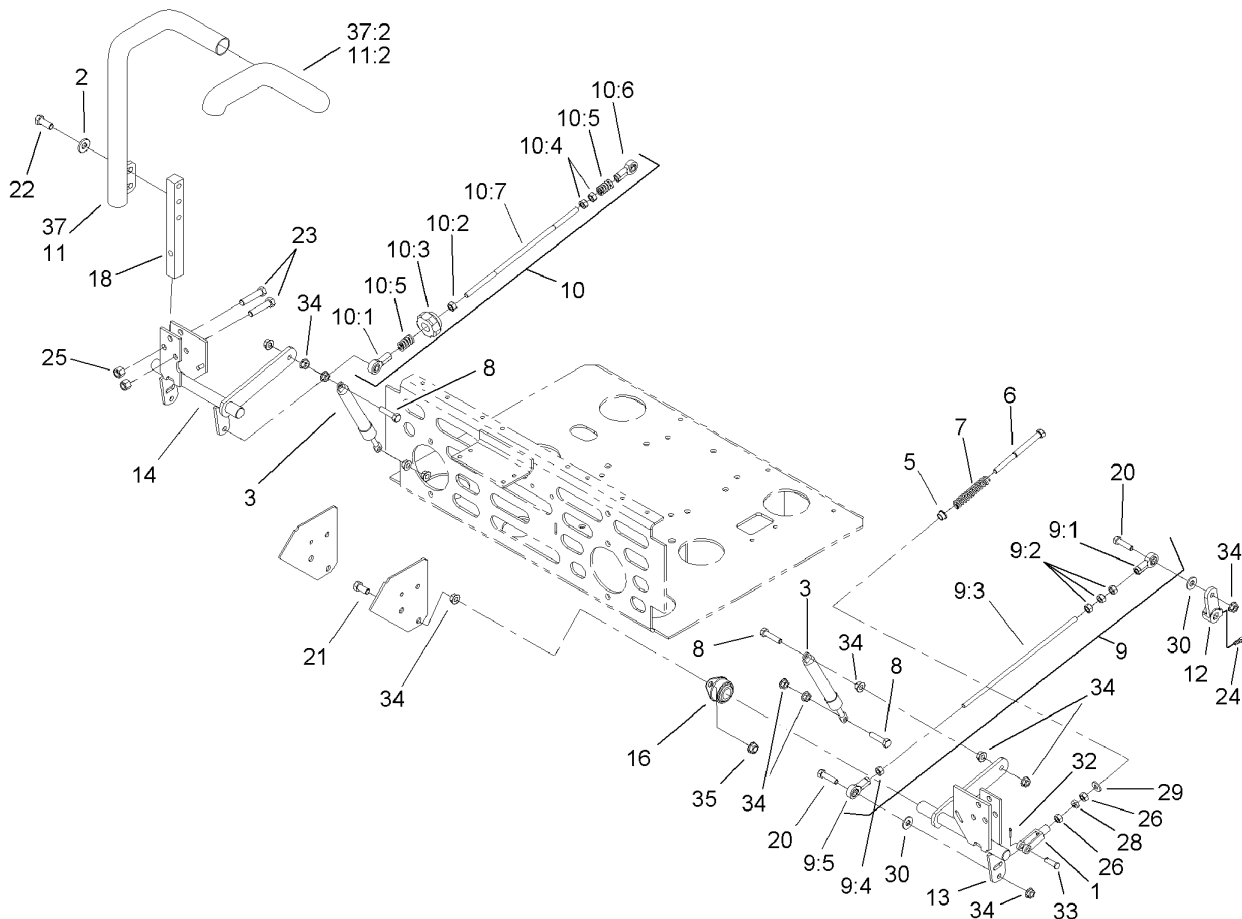

Steering Control Assembly

Ref	Part No.	Qty.	Description
1	1-303105	2	Yoke-Adjustable
2	98-5975	4	Washer-Belleville
3	103-4079	2	Damper-Control, Motion
5	1-603735	2	Bushing-Flanged
6	1-603737	2	Bolt-Return, Neutral
7	1-603807	2	Spring-Return, Neutral
8	1-403180	4	Screw-HH
9	103-4331	1	Tracking Rod ASM
9:1	1-543017	1	Balljoint-RH
9:2	3219-2	3	Nut-Hex
9:3	103-3064	1	Link-Rod, Tracking
9:4	1-804524	1	Nut
9:5	1-633152	1	Balljoint-Thread, LH
10	103-4330	1	Tracking Rod ASM
10:1	1-543017	1	Balljoint-RH
10:2	3219-2	1	Nut-Hex
10:3	103-3060	1	Knob-Tracking
10:4	1-804524	2	Nut
10:5	1-323245	2	Spring-Compression
10:6	1-633152	1	Balljoint-Thread, LH
10:7	103-3064	1	Link-Rod, Tracking
11	106-9982	1	LH Lever ASM
11:2	106-9987	1	Grip-Control, Motion
12	1-632208	2	Arm-Control, Pump

Ref	Part No.	Qty.	Description
13	103-4781	1	Control-Motion, LH
14	103-4782	1	Control-Motion, RH
16	1-633102	4	Bearing-Flange, Side
18	103-0407	2	Arm-Shaft, Control
20	322-6	4	Screw-HH
21	323-4	8	Screw-HH
22	323-6	4	Screw-HH
23	323-9	6	Screw-HH
24	1-803022	2	Screw-Set
25	3296-39	6	Nut-Lock, NI
26	3219-2	4	Nut-Hex
28	3220-2	2	Nut
29	3256-2	2	Washer-Flat
30	3256-3	4	Washer-Flat
32	3272-5	2	Pin-Cotter
33	1-808280	2	Pin-Clevis
34	32128-20	16	Nut-HF
35	3290-357	8	Nut-HHF
37	106-9983	1	RH Lever ASM
37:2	106-9987	1	Grip-Control, Motion

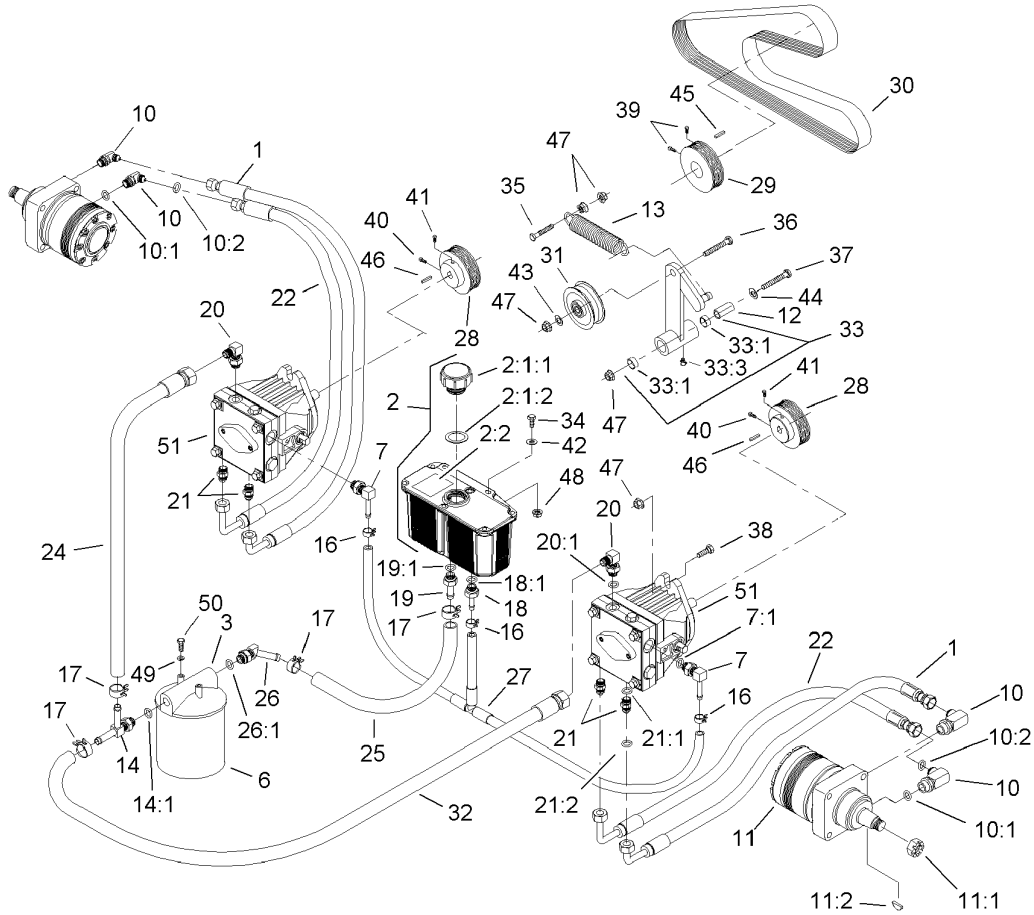

Hydraulic System Assembly

Ref	Part No.	Qty.	Description
1	103-3734	2	HYD Hose ASM
2	103-1947	1	HYD Reservoir ASM
2:1:1	103-1948	1	Cap-Reservoir, HYD
2:1:2	103-1949	1	Gasket-Cap
2:2	1-523552	1	Decal-Tank, HYD
3	104-7836	1	Head-Filter
6	1-633750	1	Filter-HYD
6	1-633752	1	Filter-Hyd, Winter
7	103-1799	2	Elbow-90 DEG
7:1	237-42	1	O-Ring
10	1-633786	4	Fitting-90 DEG
10:1	237-80	1	O-Ring
10:2	1-603992	1	O-Ring
11	1-523328	2	Motor-Wheel
11:1	1-809036	1	Nut-HH
11:2	3257-42	1	Key-Woodruff
●11:99	1-000099	1	Seal Kit
●11:99	1-000139	1	Bearing Kit
●11:99	103-2748	1	Drive Link Kit
12	1-603384	1	Bushing-Pivot, Idler
13	103-3330	1	Spring-Extension
14	103-1828	1	Adapter-Run, Tee
14:1	237-42	1	O-Ring
16	103-1716	3	Clamp-Hose

Ref	Part No.	Qty.	Description
17	103-1988	4	Clamp-Hose
18	103-1801	1	Adapter-Straight
18:1	237-42	1	O-Ring
19	103-1912	1	Adapter-Straight
19:1	237-42	1	O-Ring
20	103-1802	2	Fitting-Hyd, 90 DEG
20:1	237-42	1	O-Ring
21	1-603990	4	Fitting-Straight
21:1	237-79	1	O-Ring
21:2	1-603992	1	O-Ring
22	103-1863	2	Hose-Lower
24	103-1826	1	HYD Hose ASM
25	103-1808	1	Hose-HYD
26	103-1807	1	Elbow-45 DEG
26:1	237-42	1	O-Ring
27	103-1806	1	HYD Hose ASM
28	1-633568	2	Sheave
29	1-633567	1	Sheave
30	1-633749	1	Belt-Drive, Pump
31	1-633167	1	Sheave-Idler
32	103-1827	1	HYD Hose ASM
33	1-634277	1	Bearing Arm ASM
33:1	1-513034	2	Sleeve-Bearing
33:3	302-40	1	Fitting-Grease

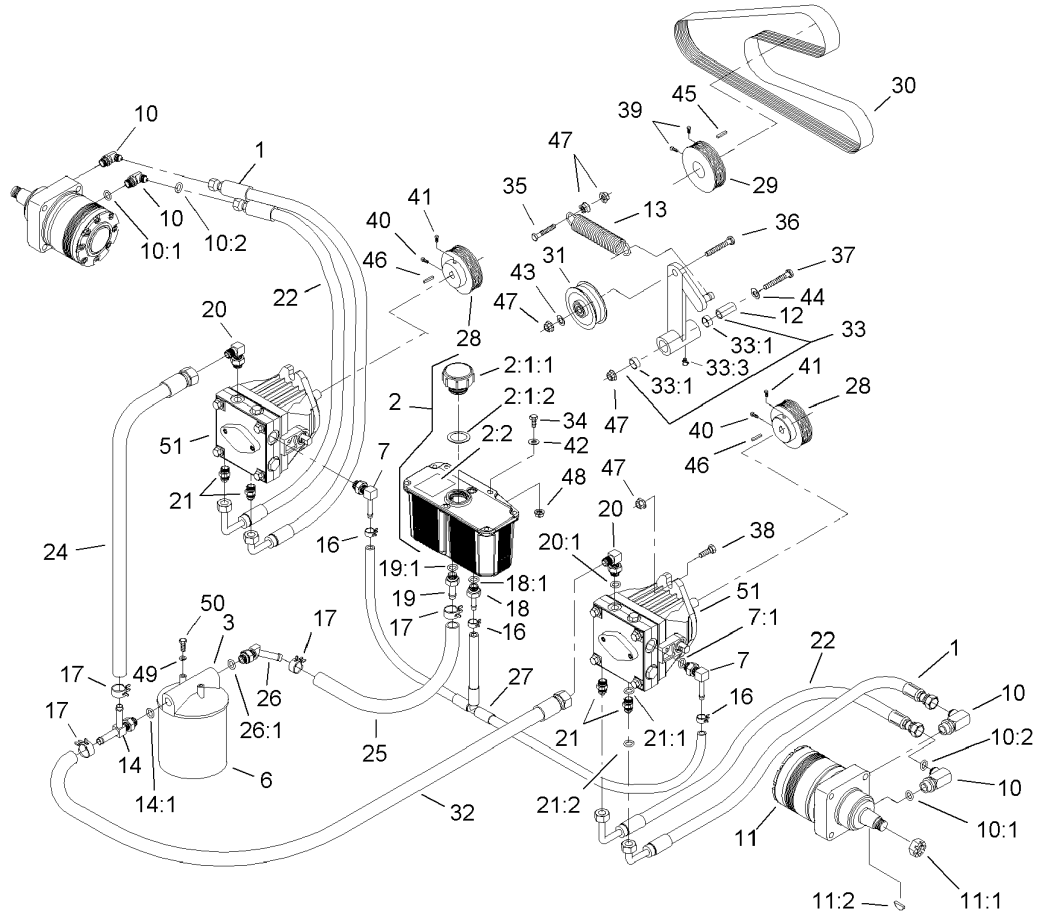

Hydraulic System Assembly (continued)

Ref	Part No.	Qty.	Description
34	321-6	2	Screw-HH
35	323-8	1	Screw-HH
36	323-9	1	Screw-HH
37	1-800805	1	Screw-HH
38	323-7	4	Screw-HH
39	1-803022	2	Screw-Set
40	30-1710	2	Screw
41	1-803050	2	Screw-Set
42	3256-22	2	Washer-Flat
43	3256-3	1	Washer-Flat
44	3256-4	1	Washer-Flat
45	13-2840	1	Key-Square
46	1-807272	2	Key
47	3290-357	8	Nut-HHF
48	32128-33	2	Nut-HF
49	1-805004	2	Washer-Lock
50	321-3	2	Screw-HH
51	103-2675	2	Pump-HYD
●51:1	103-2664	1	Input Shaft Kit
●51:2	94-6922	1	Bearing-Thrust
●51:3	103-2666	1	Cylinder Block Kit
●51:4	105-6185	1	Plate-Valve
●51:5	105-6184	1	Seal Overhaul Kit
●51:7	106-2053	1	Shock Valve Kit

--	--	--	--

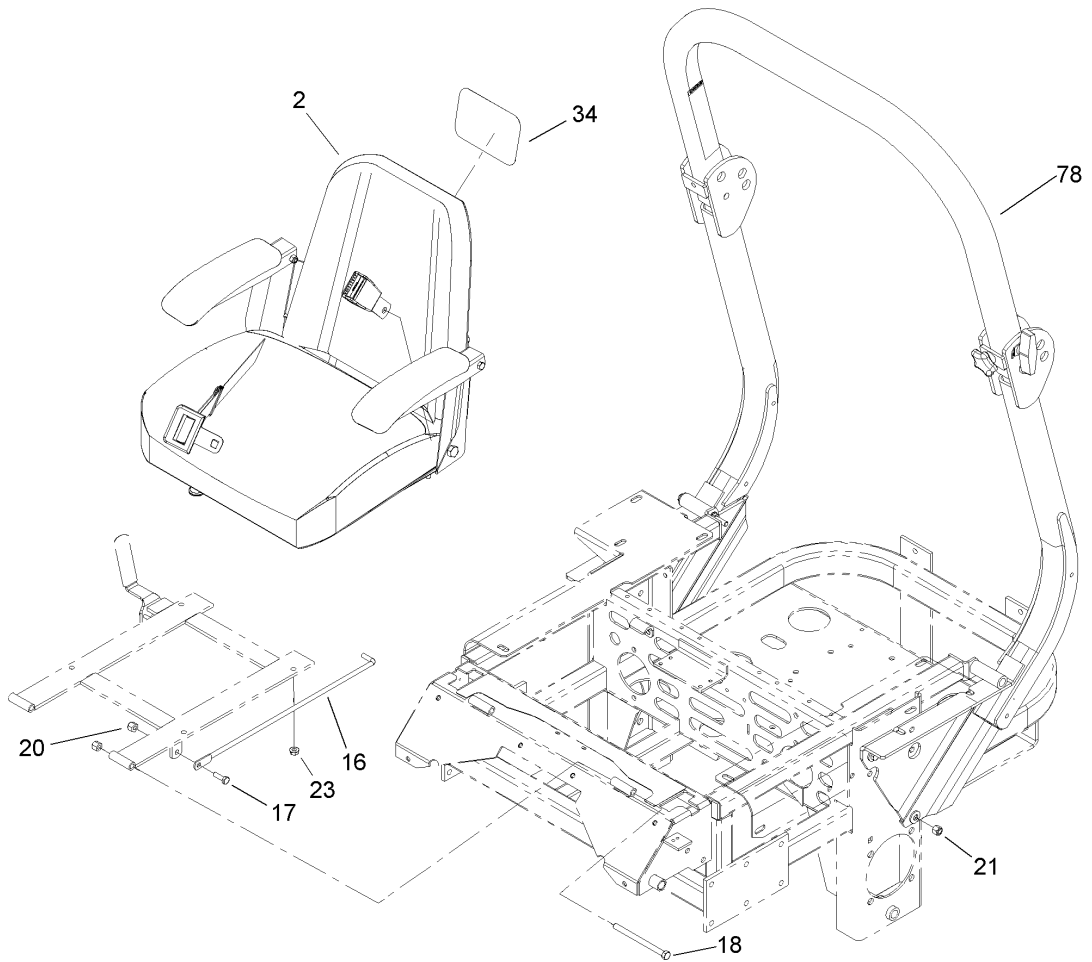

Seat and Roll-Over-Protection System Assembly

Ref	Part No.	Qty.	Description
2	106-9988	1	Seat-Suspension
16	1-633293	1	Rod-Holdup, Seat
17	322-5	1	Screw-HH
18	323-39	2	Screw-HH
20	3296-29	3	Nut-Lock, NI
21	3296-39	5	Nut-Lock, NI
23	32128-20	4	Nut-HF
34	99-4693	1	Decal
78	107-0038	1	Rops ASM

--	--	--	--

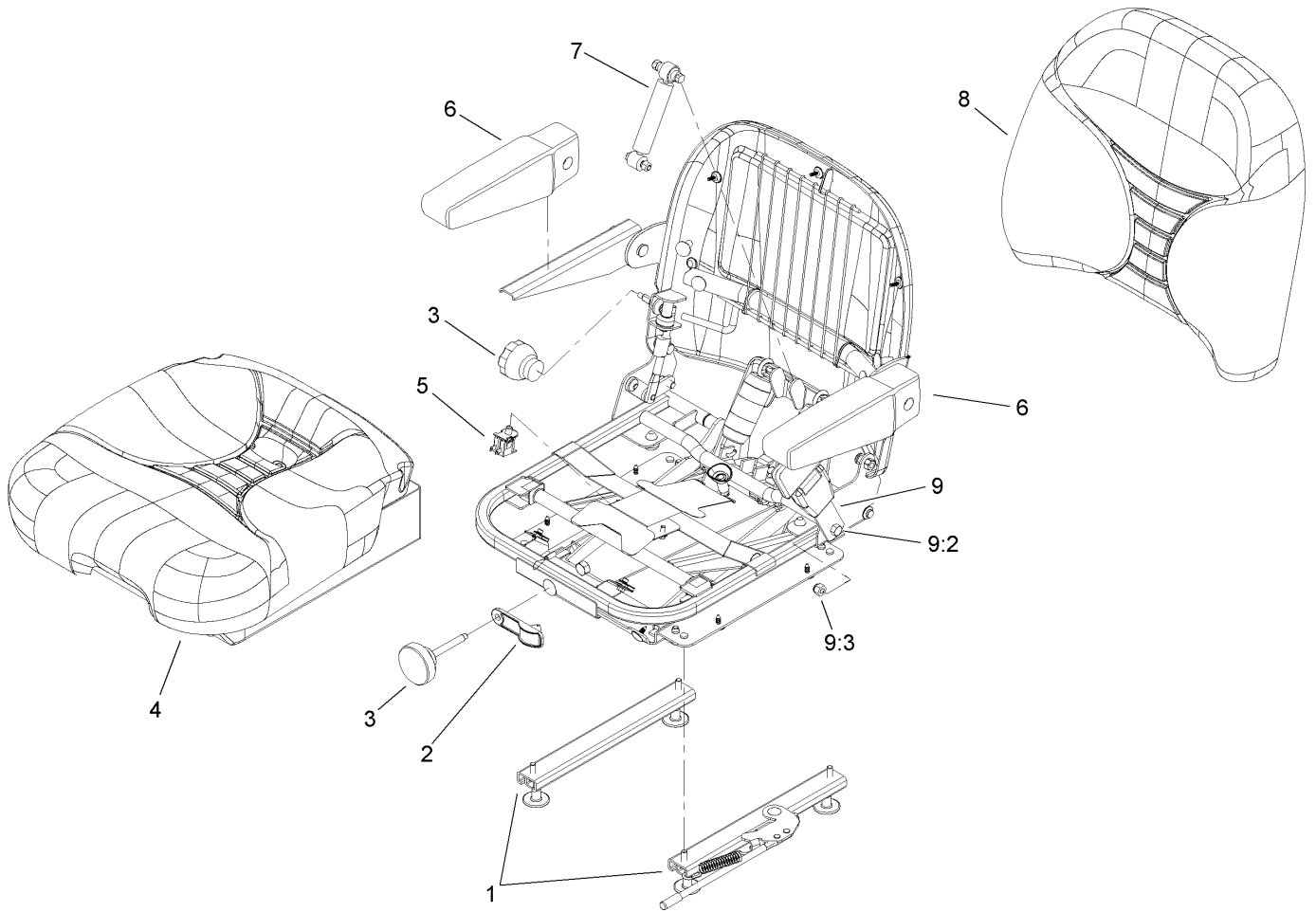

Suspension Seat Assembly No. 106-9988

Ref	Part No.	Qty.	Description				
1	107-1880	1	Seat Track Kit				
2	107-1885	1	Weight Indicator Kit				
3	107-1881	1	Knob Kit				
4	107-1883	1	Bottom Cushion Kit				
5	107-1886	1	Switch Kit				
6	107-1887	1	Armrest Kit				
7	107-1884	1	Shock Absorber Kit				
8	107-1882	1	Back Cushion Kit				
9	103-4469	1	Seatbelt Kit				
9:2	3212-4	2	Screw-HH				
9:3	3296-38	2	Nut-Lock NI				

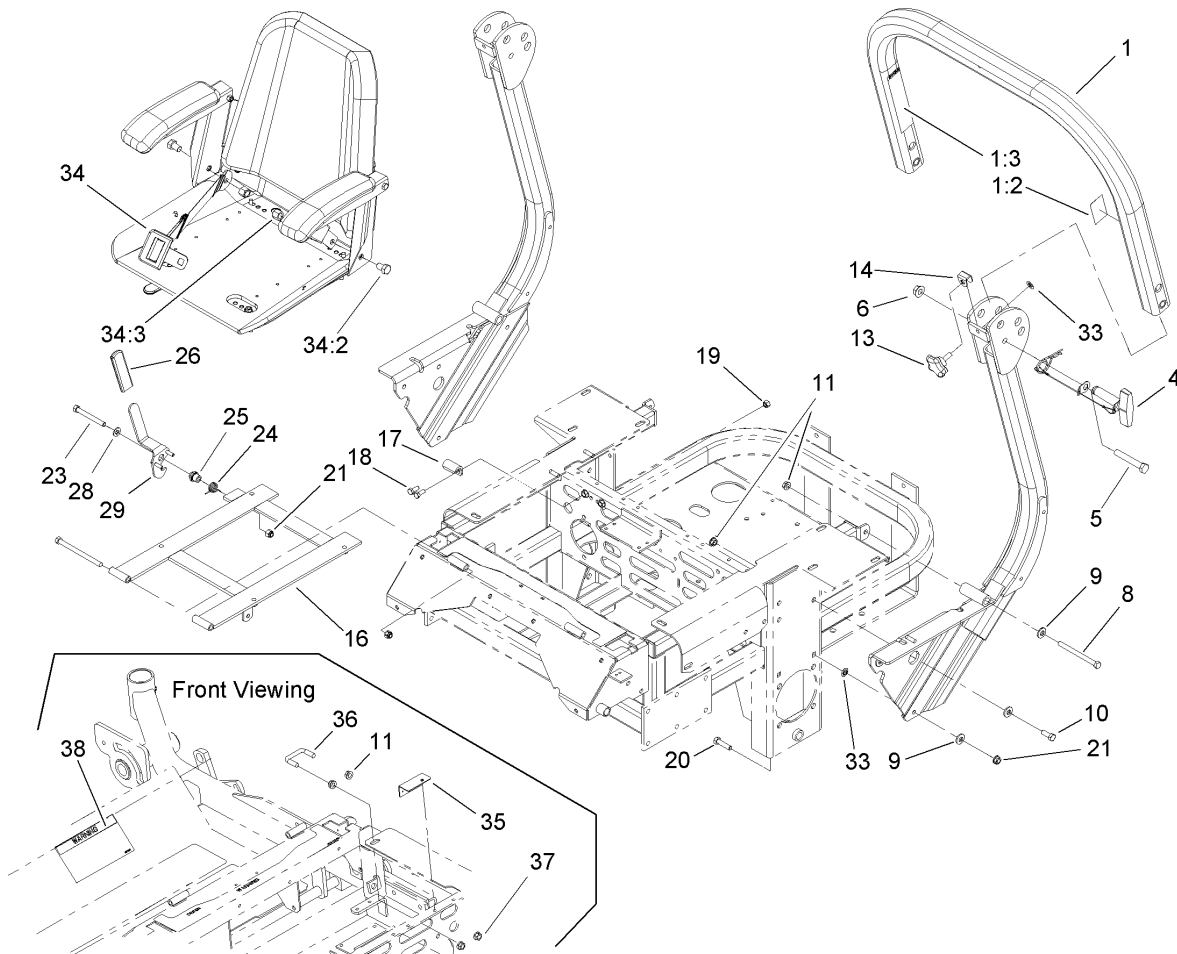

Roll-Over-Protection System Assembly No. 107-0038

Ref	Part No.	Qty.	Description
1		1	Upper Tube ASM
1:2	107-2101	1	Decal-Rops
1:3	107-2102	1	Decal-Warning, Folding Rops
4	107-3060	2	Pin Latch ASM
5	325-13	2	Screw-HH
6	32128-23	2	Nut-HF
8	323-23	2	Screw-HH
9	98-5975	8	Washer-Belleville
10	323-6	4	Screw-HH
11	3290-357	8	Nut-HHF
13	106-0887	2	Knob
14	107-3124	2	Clip
16	107-3052-03	1	Frame-Support, Seat
17	107-3058	1	Catch-Latch, Seat
18	322-3	2	Screw-HH
19	3296-29	2	Nut-Lock, NI
20	323-8	2	Screw-HH
21	3296-39	3	Nut-Lock, NI
23	323-20	1	Screw-HH
24	107-0076	1	Spring-Torsion
25	107-0075	1	Bushing-Latch, Seat
26	62-9130	1	Grip-Handle
28	3256-24	1	Washer-Flat
29	107-3083	1	Latch ASM

Ref	Part No.	Qty.	Description
33	107-3154	4	Nut-Push
34	103-4469	1	Seatbelt Kit
34:2	3212-4	2	Screw-HH
34:3	3296-38	2	Nut-Lock NI
35	107-3074	1	Template-Drill, Seat Catch
36	107-3073	1	U-Bolt
37	32128-21	2	Nut-HF
38	107-2112	1	Decal-Warning

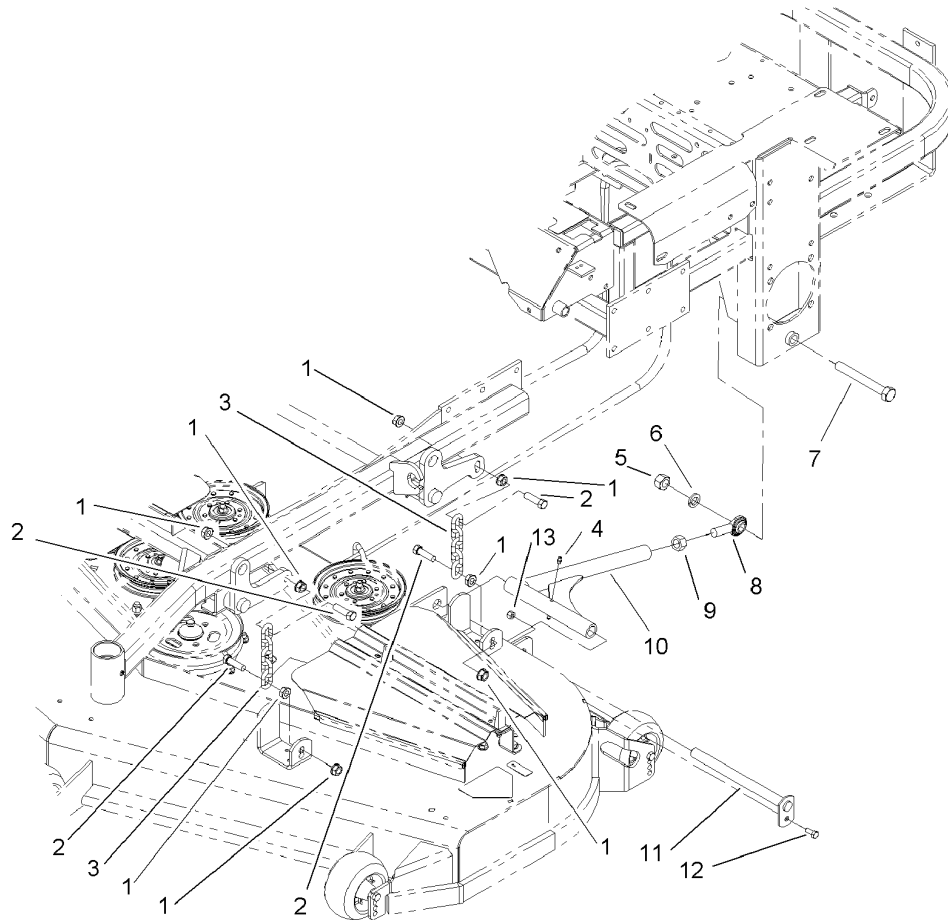

Deck Mounting Assembly

Ref	Part No.	Qty.	Description
1	32128-37	16	Nut-HF
2	103-1898	8	Screw-HH
3	1-633447	4	Chain-Lift, Deck
4	302-19	4	Fitting-Grease
5	3217-11	2	Nut-Hex
6	3253-8	2	Washer-Lock
7	327-11	2	Screw-HH
8	1-633029	2	Balljoint-Spherical
9	3219-6	2	Nut-Hex
10	103-1072-01	2	Strut
11	1-632199-01	2	Pin-Strut
12	322-3	2	Screw-HH
13	3296-29	2	Nut-Lock, NI

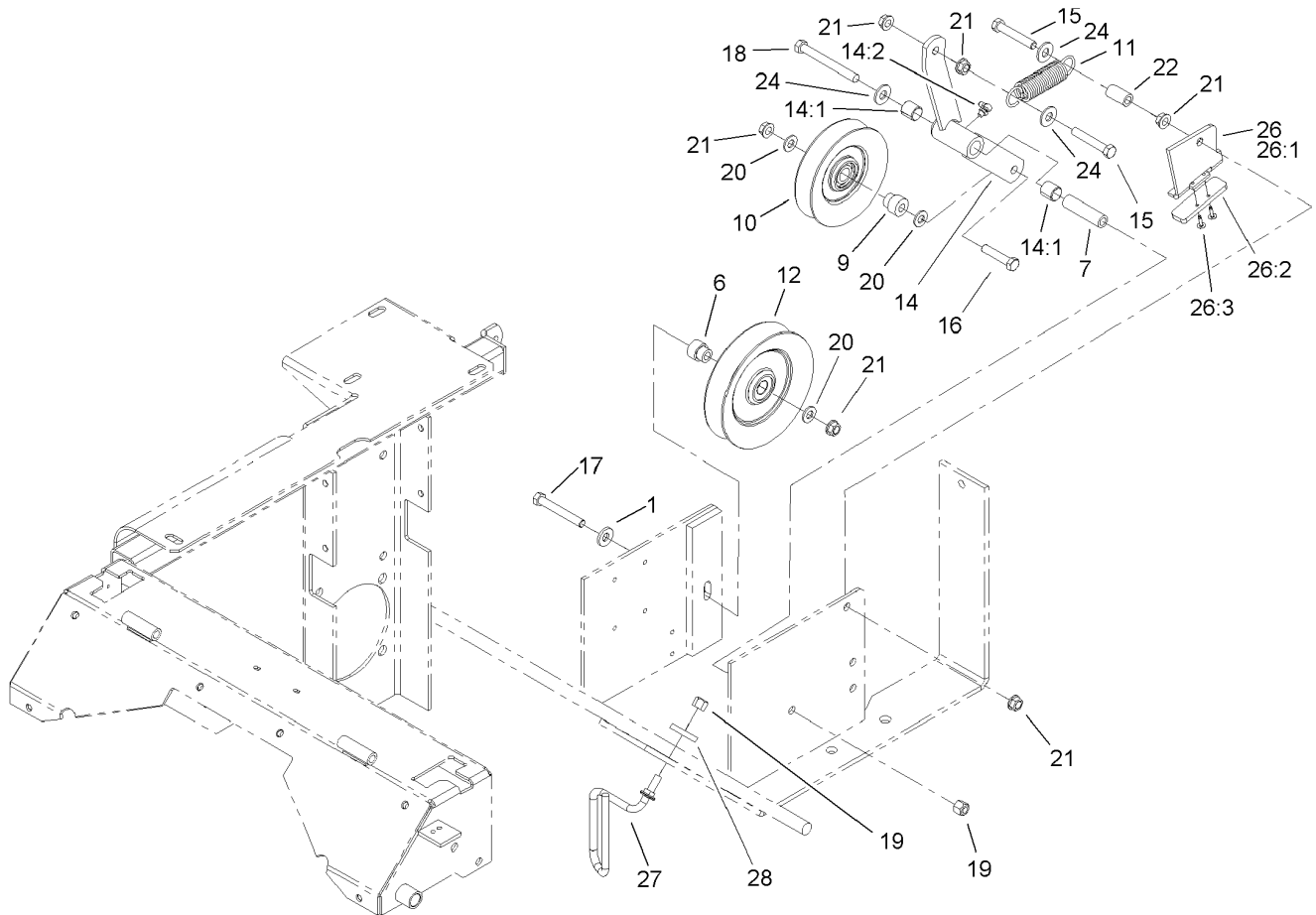

Drive Idler Assembly

Ref	Part No.	Qty.	Description
1	98-5975	1	Washer-Belleville
6	103-2627	1	Bushing-Idler
7	1-603384	1	Bushing-Pivot, Idler
9	1-603496	1	Bushing-Idler
10	99-4638	1	Idler
11	1-603402	1	Spring-Extension
12	1-633166	1	Pulley-Idler
14	103-3147	1	Arm ASM
14:1	1-513034	2	Sleeve-Bearing
14:2	302-40	1	Fitting-Grease
15	323-12	2	Screw-HH
16	323-9	1	Screw-HH
17	323-13	1	Screw-HH
18	1-800805	1	Screw-HH
19	3296-39	2	Nut-Lock, NI
20	3256-24	3	Washer-Flat
21	3290-357	6	Nut-HHF
22	1-603401	1	Spacer-Fender
24	3256-4	3	Washer-Flat
26	106-3271	1	Travel Limiter ASM
26:1	106-3228-03	1	Plate-Limiter, Pulley
26:2	106-3229	1	Pad-Bumber
26:3	3269-24	2	Rivet
27	105-7772	1	Guide-Belt

Ref	Part No.	Qty.	Description
28	112843	1	Washer

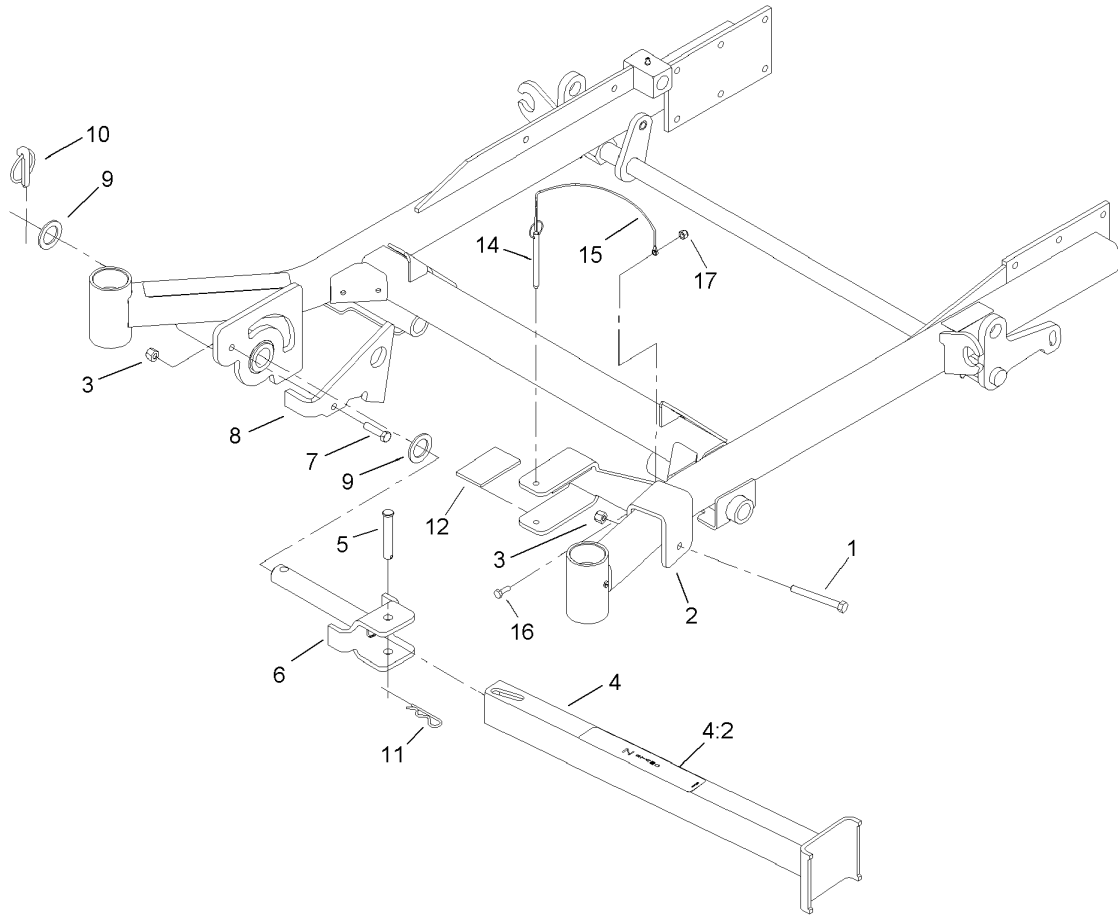

Z-Stand Assembly

Ref	Part No.	Qty.	Description				
1	323-20	1	Screw-HH				
2	100-6542-01	1	Bracket-Cradle				
3	3296-39	2	Nut-Lock, NI				
4	107-1874	1	Leg ASM				
4:2	106-7464	1	Decal-Z Stand				
5	283-55	1	Pin-Clevis				
6	100-9692-01	1	Pivot Pin ASM				
7	323-8	1	Screw-HH				
8	100-9686-01	1	Bracket-Latch				
9	3-6781	2	Washer-Thrust				
10	283-71	1	Pin-Lynch				
11	3290-355	1	Pin-Hair				
12	100-6547	2	Cushion-Rubber				
14	105-1647	1	Pin-Hitch, Cotterless				
15	100-9385	1	Lanyard-Nylon				
16	321-4	1	Screw-HH				
17	3296-42	1	Nut-Lock, NI				

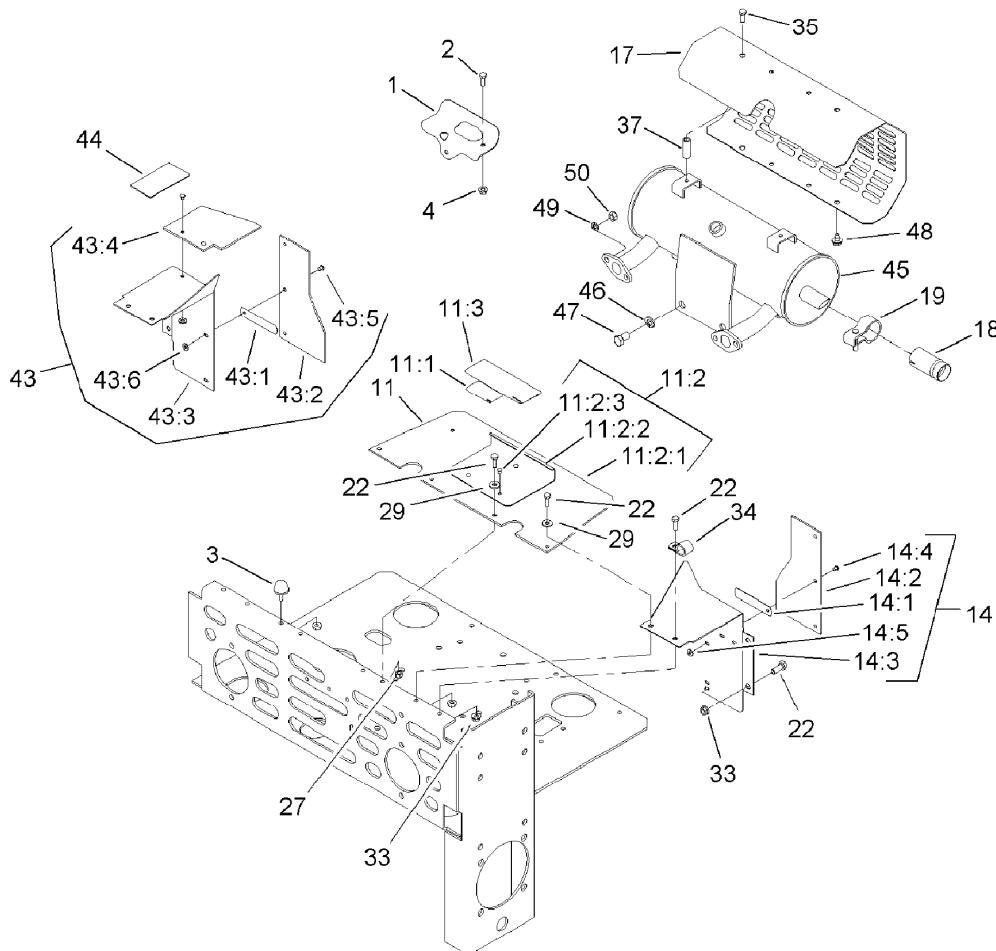

Muffler and Guard Assembly

Ref	Part No.	Qty.	Description
1	103-3535	1	Cable Heat Shield Kit
2	321-4	1	Screw-HH
3	1-523420	2	Bumper
4	32128-33	1	Nut-HF
11	1-644276	1	Shield ASM
11:1	1-633462	1	Decal-Important
11:2	1-634308	1	Shield/lift ASM
11:2:1	103-1308	1	Shield-Engine
11:2:2	1-633300-03	1	Lift-Shield
11:2:3	1-803035	3	Rivet-Pop
11:3	103-5881	1	Decal-Devices, Rotating
14	1-634796	1	LH Shield ASM
14:1	1-523285	1	Clip-Baffle, Rear
14:2	1-633301	1	Shield-Engine
14:3	1-633795-03	1	Baffle-Engine Shield, LH
14:4	1-803035	3	Rivet-Pop
14:5	3256-63	3	Washer-Flat
17	1-643313-03	1	Guard-Muffler
18	103-1513	1	Arrester-Spark
19	103-1514	1	Clamp-Muffler
22	321-4	10	Screw-HH
27	3296-42	7	Nut-Lock, NI
29	3256-2	4	Washer-Flat
33	32128-33	6	Nut-HF

Ref	Part No.	Qty.	Description
34	1-633396	1	Clip-Loom
35	1-809108	2	Screw-HWH
37	1-323236	2	Spacer
43	1-644316	1	RH Shield ASM
43:1	1-523285	1	Clip-Baffle, Rear
43:2	1-633301	1	Shield-Engine
43:3	1-633794-03	1	Shield-RH
43:4	1-643315	1	Baffle-Cooler, Engine
43:5	1-803035	5	Rivet-Pop
43:6	3256-63	5	Washer-Flat
44	1-643339	1	Decal-Routing, Belt
45	103-2757	1	Muffler
46	3253-6	2	Washer-Lock
47	324-2	2	Screw-HH
48	9266934	2	Screw
49	1-805005	4	Washer-Lock
50	33014-00	4	Nut-Hex

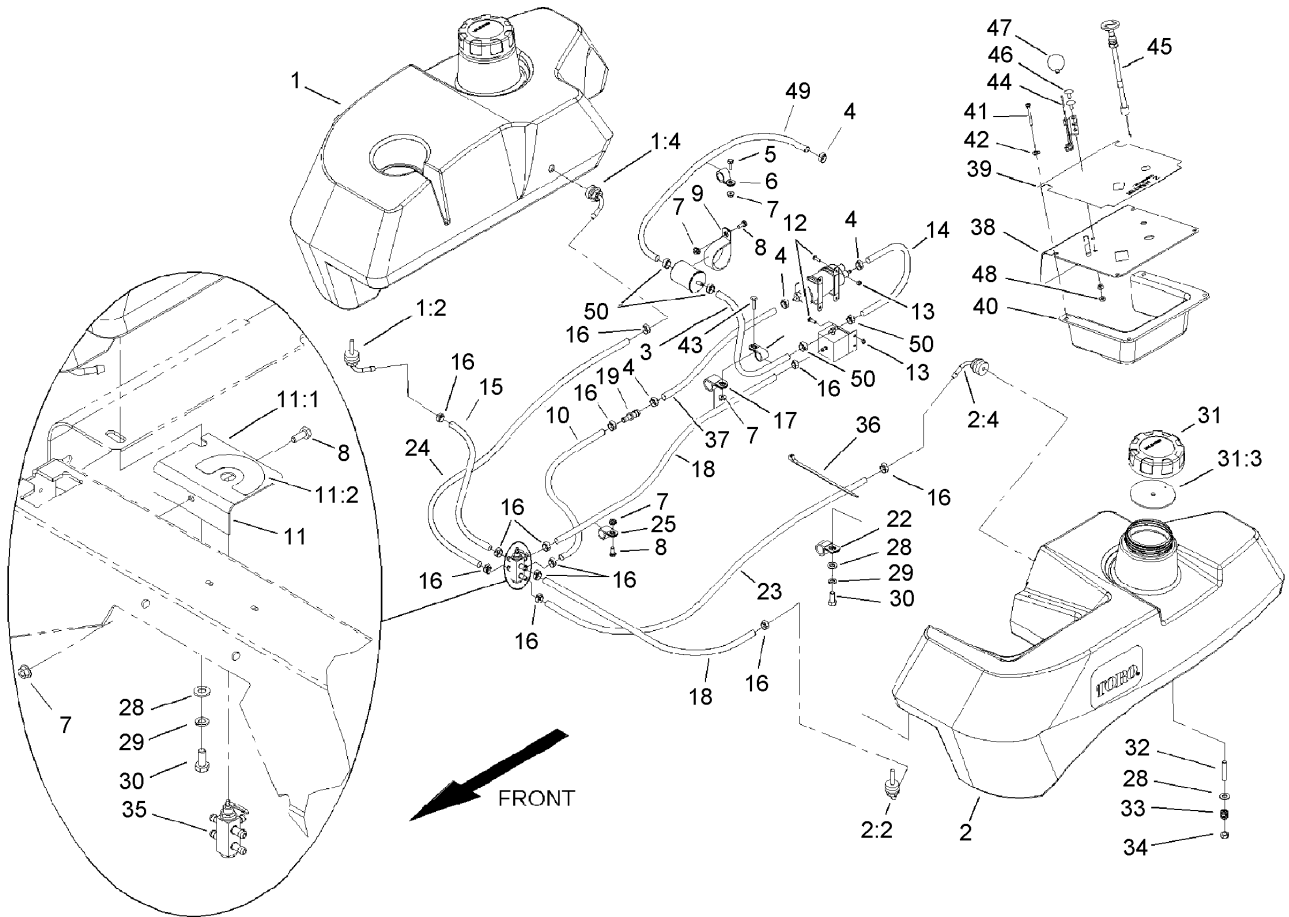

Fuel Assembly

Ref	Part No.	Qty.	Description
1	106-9977	1	RH Fuel Tank ASM
1:2	103-2605	1	Fitting-Fuel, Bulkhead
1:4	103-2615	1	Fitting-Fuel, Bulkhead
2	106-9978	1	LH Fuel Tank ASM
2:2	103-2605	1	Fitting-Fuel, Bulkhead
2:4	103-2615	1	Fitting-Fuel, Bulkhead
3	103-2491	1	Hose-Fuel
4	1-643277	4	Clamp-Hose, Fuel
5	321-4	1	Screw-HH
6	1-603727	2	Clip-Loom
7	32128-33	5	Nut-HF
8	321-3	4	Screw-HH
9	1-643241	1	Clip-Loom
10	99-7190	1	Hose-Fuel
11	107-2115	1	Fuel Valve ASM
11:1		1	Bracket-Valve, Fuel
11:2	107-2114	1	Decal-Valve, Fuel
12	3290-500	6	Screw-PPH
13	3296-2	6	Nut-Lock
14	103-2490	1	Hose-Fuel
15	103-2944	1	Hose-Fuel
16	1-643293	12	Clamp-Hose, Fuel
17	1-643312	1	Clip-Loom
18	63-7722	2	Hose-Fuel

Ref	Part No.	Qty.	Description
19	103-2595	1	Connector
22	103-0373	1	Clip
23	107-1889	1	Hose-Fuel
24	99-7191	1	Hose-Fuel
25	1-513762	3	Clip-Loom
28	3256-23	8	Washer-Flat
29	1-805005	2	Washer-Lock
30	322-3	2	Screw-HH
31	88-3980	2	Gas Cap ASM
31:3	88-4010	1	Gasket-Cap, Gas
32	1-633023	6	Stud
33	1-633349	6	Spring-Tank, Fuel
34	3296-47	6	Nut-Lock, NI
35	1-643234	1	Valve-Fuel, Dual Flow
36	1-303287	6	Tie-Plastic
37	93-5484	1	Hose-Fuel
38	106-9966-03	1	Panel-Control
39	106-9969	1	Decal-Panel, Control
40	99-4940	1	Shield-Panel, Control
41	1-803071	4	Screw
42	1-303435	4	Washer-Spring
43	321-6	1	Screw-HH
44	1-633696	1	Cable-Throttle
45	106-9962	1	Control-Choke, Push/pull

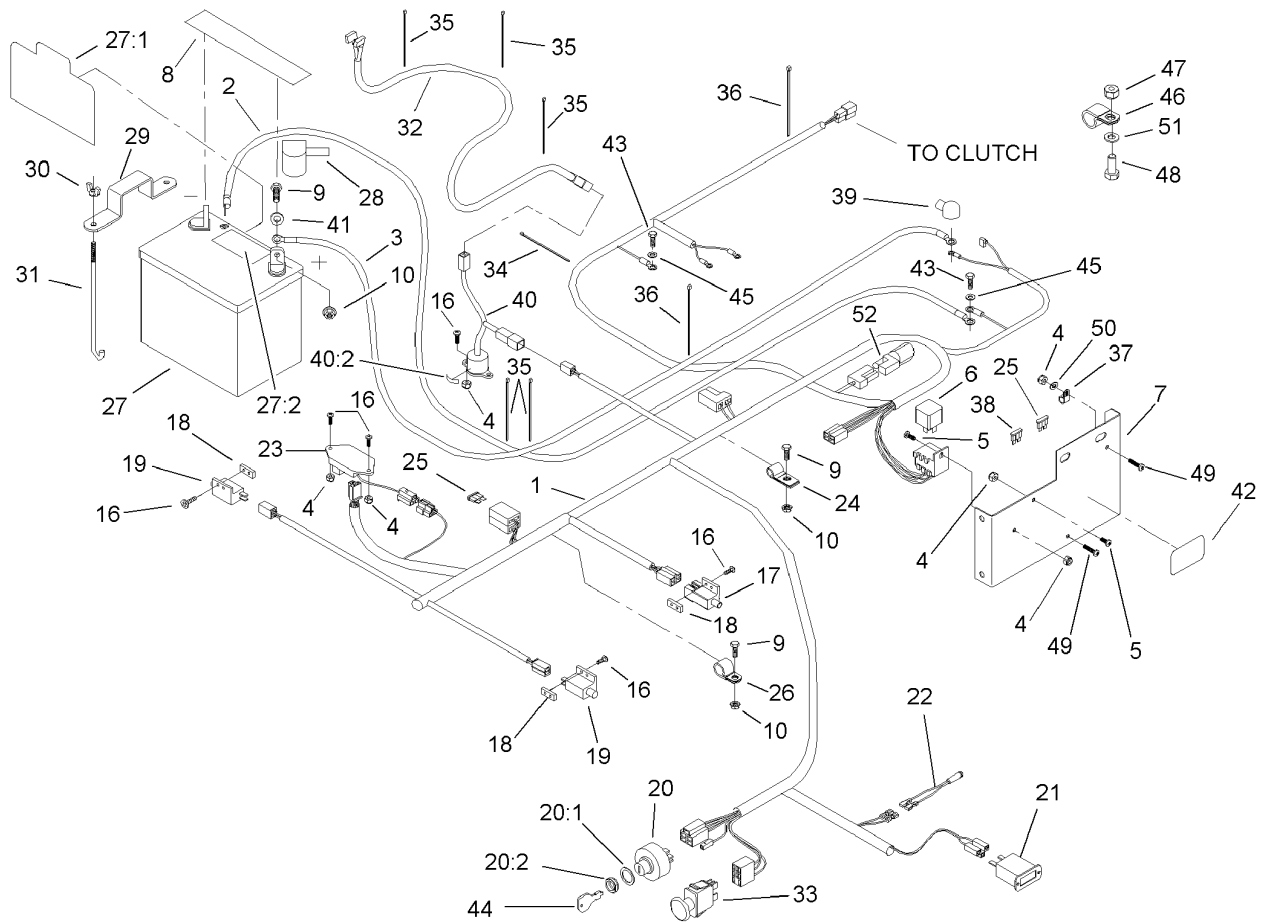

Electrical Assembly

Ref	Part No.	Qty.	Description
1	106-7495	1	Harness-Wire
2	1-633307	1	Wire-Ground
3	1-523279	1	Wire-Battery, Positive
4	3296-2	10	Nut-Lock
5	1-803071	4	Screw
6	1-643275	2	Relay
7	103-2549-03	1	Panel-Mount, Fuse
8	105-3646	1	Decal-Warning, Battery
9	321-4	6	Screw-HH
10	32128-33	6	Nut-HF
16	3290-500	8	Screw-PPH
17	1-633111	1	Switch
18	1-633181	3	Plate-Tapped
19	1-513051	2	Switch-Open, Normally
20	88-9830	1	Key Switch ASM
20:1	3254-5	1	Washer-Tooth
20:2	218-461	1	Nut-HH
21	1-513374	1	Meter-Hour
22	1-643267	1	Indicator-Led, Red
23	100-6186	1	Module-Delay, Seat
24	1-513762	2	Clip-Loom
25	1-816001	2	Fuse-Blade Type, 20 Amp
26	103-0373	1	Clip
27	105-1692	1	Battery

Ref	Part No.	Qty.	Description
27:1	104-4163	1	Decal-Battery
27:2	104-4164	1	Decal-Battery
28	1-543391	1	Insulator-Battery
29	1-633652-03	1	Strap-Holddown
30	1-543792	2	Wingnut
31	1-633651	2	Bolt-Holddown
32	103-1227	1	Harness-Wiring, Seat
33	1-633673	1	Switch-Delta
34	1-303287	2	Tie-Plastic
35	1-303335	5	Tie-Plastic
36	1-643115	2	Tie-Plastic
37	1-323229	1	Clip-Loom
38	1-816002	1	Fuse-Blade Type, 10 Amp
39	1-543393	1	Insulator-Solenoid
40	1-644427	1	Tilt Switch ASM
40:2	1-643401	1	Decal-Switch, Mercury
41	3256-2	2	Washer-Flat
42	103-2750	1	Decal-Relay/fuse
43	33114-016	2	Screw-HH
44	63-8360	2	Key-Ignition
45	3256-23	2	Washer-Flat
46	1-643312	1	Clip-Loom
47	3296-42	1	Nut-Lock, NI
48	321-6	1	Screw-HH

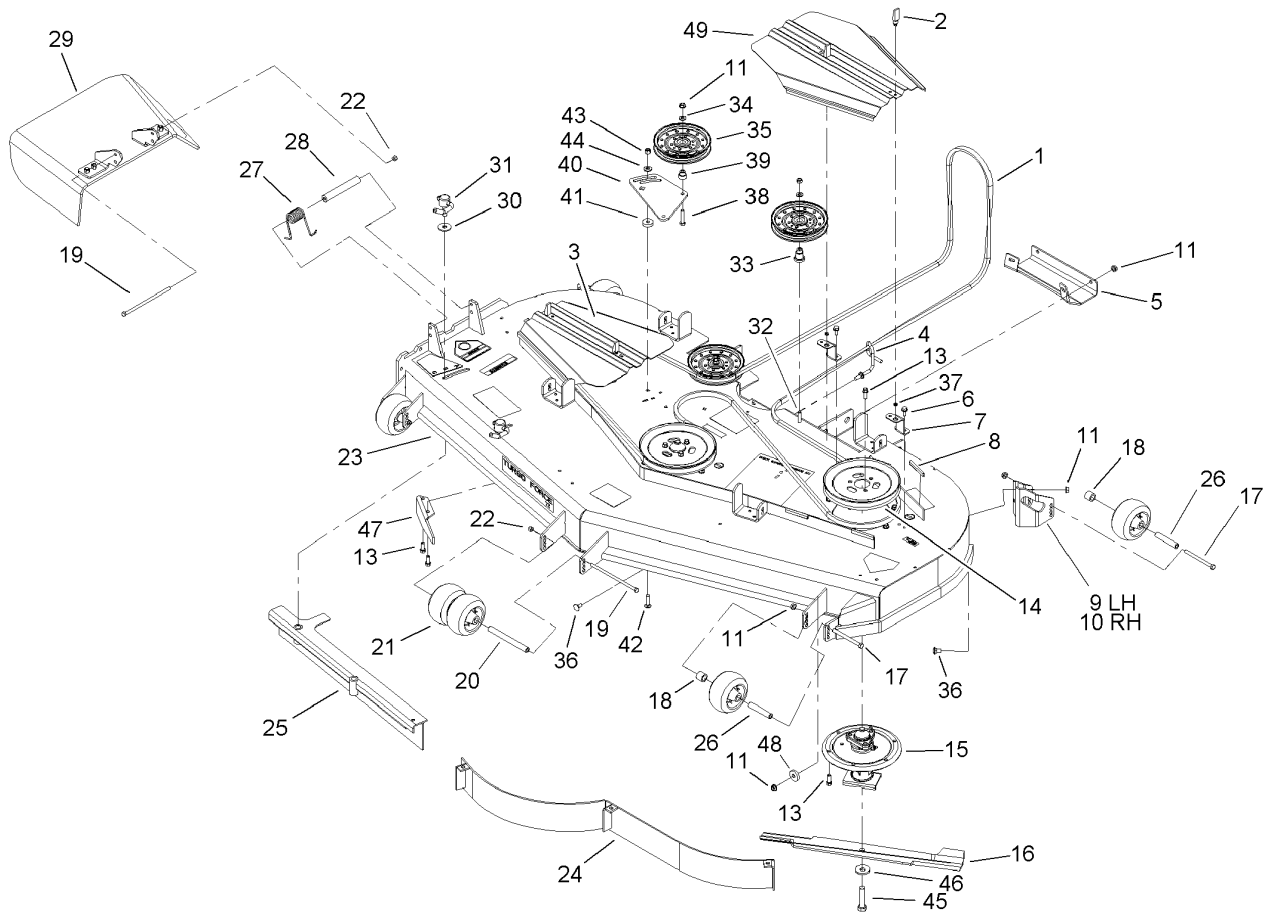

72 Inch Deck Assembly

Ref	Part No.	Qty.	Description
1	106-7350	1	Belt
2	74-5950	4	Latch-Swell
3	105-8786-01	1	Cover-Belt
4	106-3220	1	Guide-Wire
5	106-3279-01	1	Plate-Skid
6	32144-70	4	Screw-HH
7	105-8787-01	4	Bracket-Cover
8	105-7699	8	Seal-Strip
9	106-7354-01	1	Plate-Roller, LH
10	106-7355-01	1	Plate-Roller, RH
11	3290-357	24	Nut-HHF
13	92-1624	33	Screw-Mount, Engine
14	105-7733	3	Pulley
15	106-3217	3	Spindle ASM
16	105-7784	3	Blade-Rotary, 24.5 High Flow
17	323-23	4	Screw-HH
18	98-7913	4	Tube-Spacer
19	322-50	2	Screw-HH
20	98-5967	1	Spacer
21	1-603299	6	Roller-Anti Scalp
22	3296-29	2	Nut-Lock, NI
23	107-1625	1	Deck ASM
24	105-7730-01	1	Baffle ASM
25	105-7669-01	1	Baffle ASM

Ref	Part No.	Qty.	Description
26	98-7912	4	Tube-Spacer
27	104-8554	1	Spring-Torsion
28	105-4622	1	Spacer
29	106-3249	1	Rubber Deflector ASM
30	105-7697	2	Washer-Plastic
31	106-3242	2	Lever ASM
32	323-12	2	Screw-HH
33	106-3214	2	Support-Pulley
34	3256-24	3	Washer-Flat
35	1-633109	3	Idler-Flat
36	3231-1	10	Screw-CARR
37	99-3058	4	Washer
38	323-9	1	Screw-HH
39	1-603496	1	Bushing-Idler
40	105-7787-01	1	Plate-Idler
41	105-7788	2	Spacer
42	3231-4	2	Screw-CARR
43	3296-39	2	Nut-Lock, NI
44	98-5975	1	Washer-Belleville
45	103-0862	3	Screw-Cap
46	103-0865	3	Washer-Blade Bolt, Heavy
47	106-3216-01	1	Baffle-Discharge
48	112843	1	Washer
49	106-3275-01	1	Cover-Belt

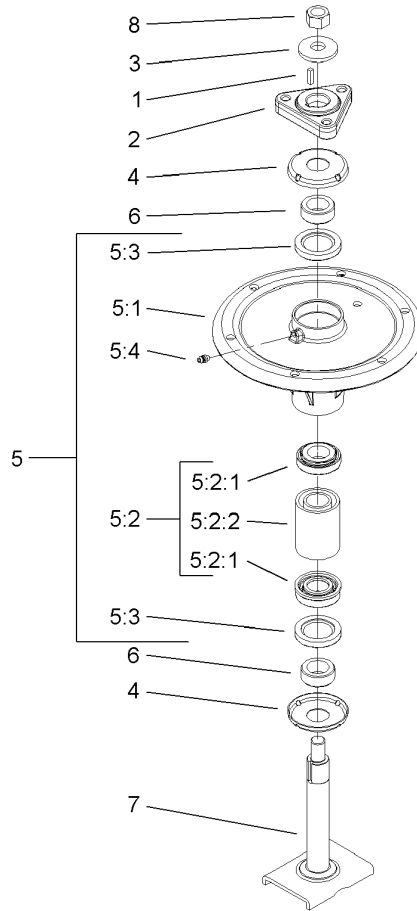

Spindle Assembly No. 106-3217

Ref	Part No.	Qty.	Description	
1	10-8040	1	Key-Square	
2	106-3277	1	Hub-Pulley	
3	103-0865	1	Washer-Blade Bolt, Heavy	
4	106-3204	2	Shield-Bearing	
5		1	Spindle Bearing ASM	
5:1	106-3211	1	Housing-Spindle	
5:2	106-3207	1	Bearing ASM	
5:2:1	27-0960	1	Bearing ASM	
5:2:2	106-3206	1	Spacer-Set, Matched	
5:3	253-133	2	Seal-Oil	
5:4	302-5	1	Fitting-Grease	
6	106-3218	2	Spacer-Seal	
7	106-3233	1	Spindle Shaft ASM	
8	3219-6	1	Nut-Hex	

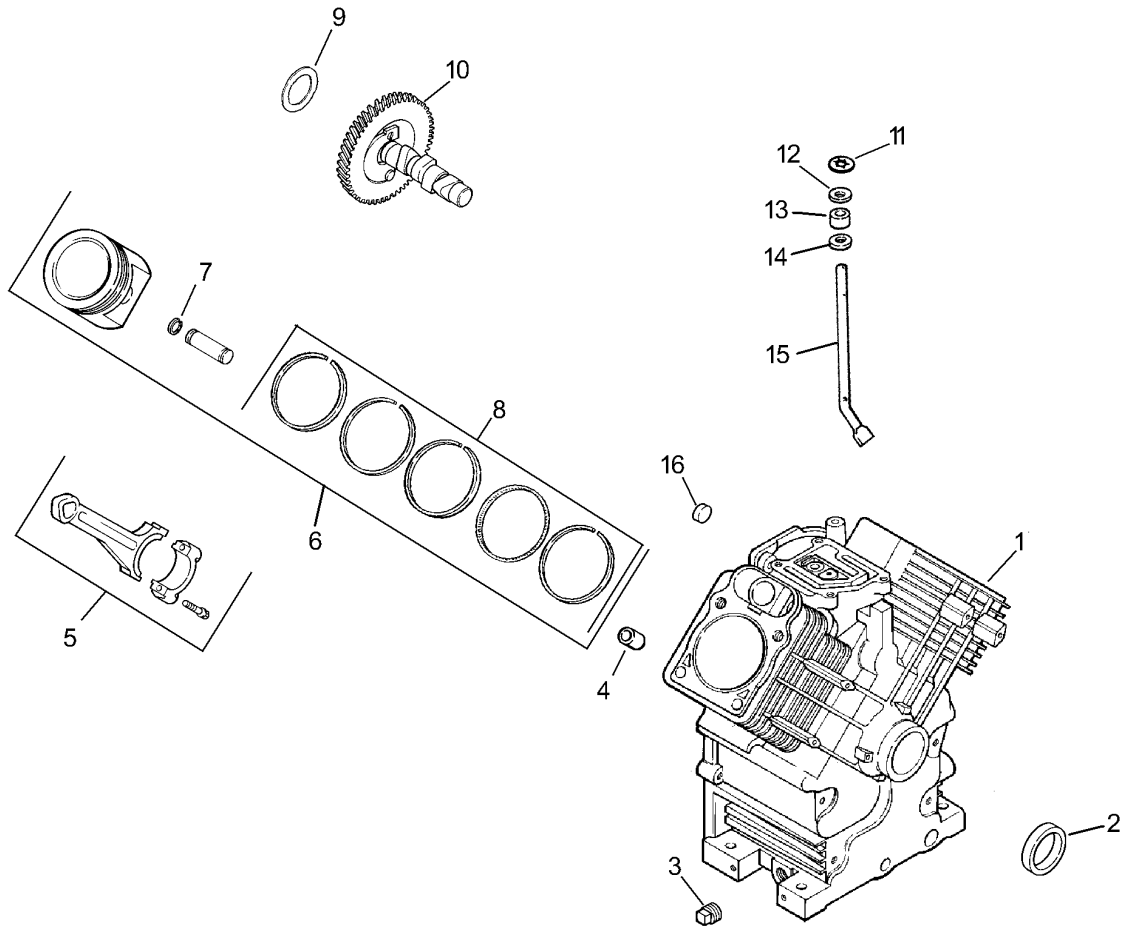

Crankcase Assembly Kohler CH745-0003

Ref	Part No.	Qty.	Description
1		1	Crankcase (Use: Miniblock 24 782 36)
2	24 032 01-S	1	Seal-Oil, Front
3	25 139 57-S	2	Plug-SQH Pipe, 3/8in N.p.t.f.
4	24 380 13-S	6	Pin-Locating
5	24 067 13-S	2	Rod-Connecting (Std.)
6	24 067 14-S	2	Rod-Connecting (.25)
7	24 874 08-S	2	Piston W/ring Set (Std.)(Includes 7,8)
8	24 874 16-S	2	Piston W/ring Set (.080)
9	24 874 20-S	2	Piston W/ring Set (.25)
10	24 874 21-S	2	Piston W/ring Set (.50)
11	24 018 01-S	4	Retainer-Pin, Piston
12	24 108 04-S	2	Set-Ring (Std)
13	24 108 06-S	2	Ring Set (.25)
14	24 108 07-S	2	Ring Set (.50)
15	12 422 09-S	0	Shim-Camshaft, Red
16	12 422 13-S	0	Shim-Camshaft, Black
17	12 422 07-S	0	Shim-Camshaft, White
18	12 422 08-S	0	Shim-Camshaft, Blue
19	12 422 18-S	1	Shim, Camshaft-Yellow
20	12 422 11-S	0	Shim-Camshaft, Green
21	12 422 12-S	0	Shim-Camshaft, Gray
22	24 012 10-S	1	Camshaft

Ref	Part No.	Qty.	Description
11	24 018 09-S	1	Ring-Retainer
12	M-931010-S	1	Washer-Nylon (Top)
13	28 032 09-S	1	Seal-Governor Cross Shaft
14	24 468 15-S	1	Washer (Bottom)
15	24 144 38-S	1	Shaft-Governor Cross
16	52 139 09-S	1	Plug-Cup

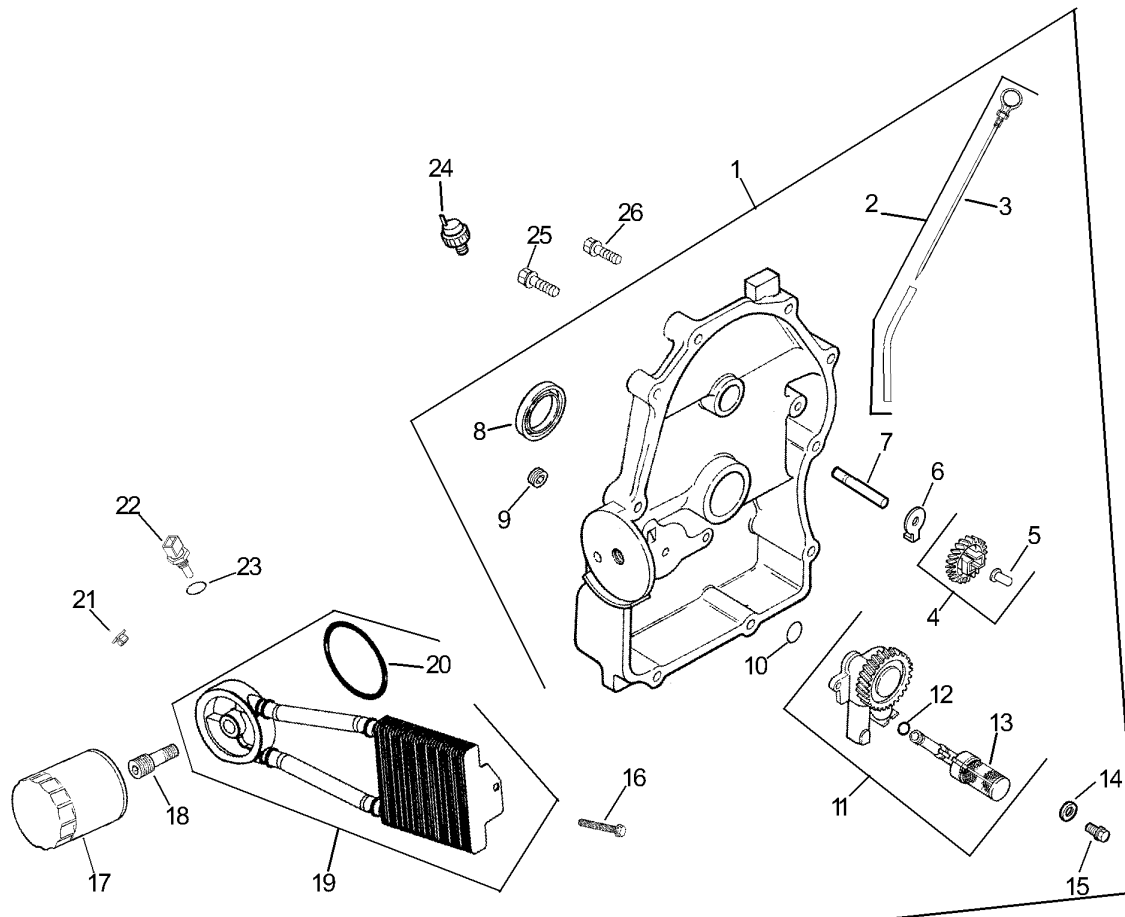

Oil Pan/Lubrication Assembly Kohler CH745-0003

Ref	Part No.	Qty.	Description
1	24 009 83-S	1	Plate Assembly, Closure (Includes 2-15)
2	24 755 121-S	1	Kit, Dipstick And Tube (Includes 3)
3	24 038 10-S	1	Dipstick
4	24 043 12-S	1	Kit, Governor Gear (Includes 5)
5	12 380 01-S	1	Pin-Governor Regulating
6	24 448 01-S	1	Tab, Locking
7	12 144 02-S	1	Shaft-Governor Gear
8	52 032 08-S	1	Seal-Oil (Pto End)
9	25 139 60-S	1	Plug-Allen Hd., 1/8 Pipe
10	24 153 08-S	1	O-Ring
11	24 393 37-S	1	Pump Assembly, Oil (Includes 12,13)
12	24 153 01-S	1	O-Ring, Oil Pick-Up
13	24 381 04-S	1	Pick-Up, Oil
14	M-631005-S	2	Washer-Plain, 6mm
15	M-645025-S	1	Screw-Hex. Flange, M6x1.0x25
16	25 086 49-S	2	Screw-Tapping 1/4-1x3/4"
17	52 050 02-S	1	Filter-Oil
18	24 136 05-S	1	Nipple, Oil Filter
19	24 594 31-S	1	Cooler, Oil (Includes 20)
20	24 153 21-S	1	O-Ring, Oil Cooler
21	24 100 01-S	2	Nut-Plastic
22	24 418 12-S	1	Sensor, Temperature

Ref	Part No.	Qty.	Description
23	12 153 04-S	1	O-Ring, Oil Pick-Up
24	24 099 03-S	1	Switch-Pressure
25	24 086 16-S	9	Screw-Hex. Flange, M8x1.25x45
26	24 086 17-S	1	Screw-Hex. Flange, M8x1.25x45
1	24 113 25-S	1	Decal, Oil Cooler

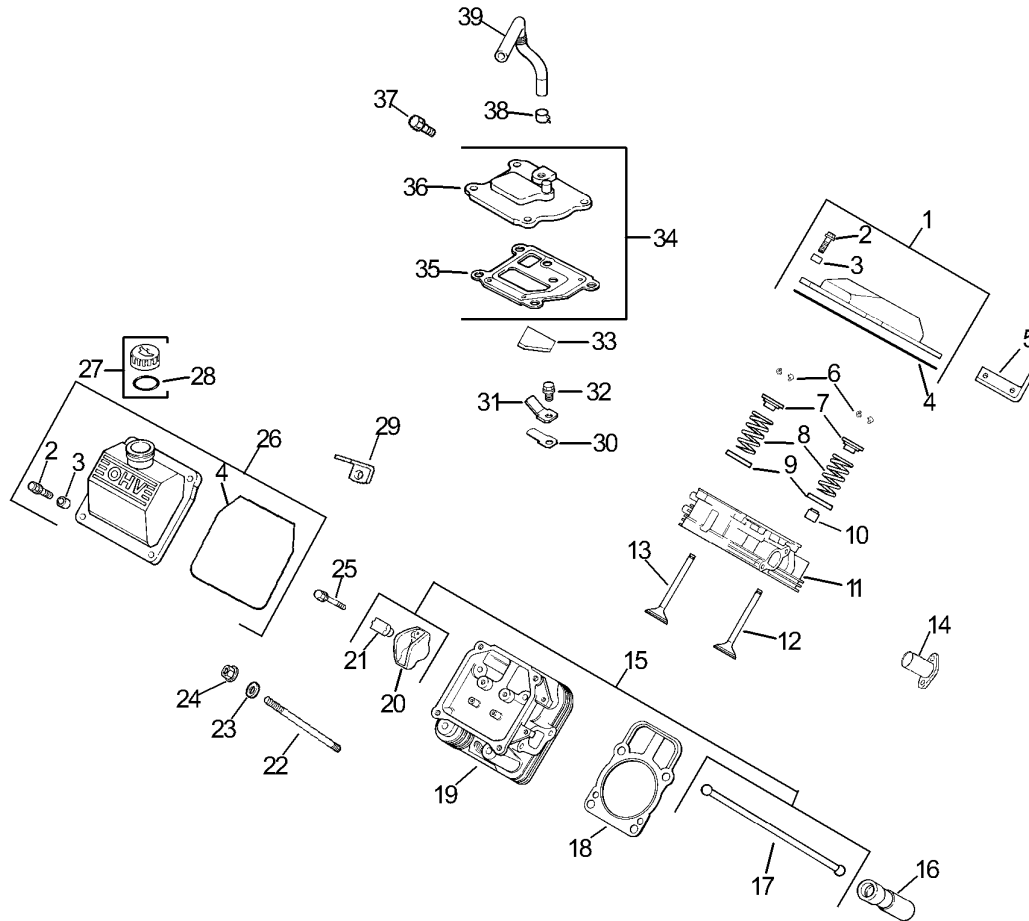

Head/Valve/Breather Assembly Kohler CH745-0003

Ref	Part No.	Qty.	Description
1	24 755 74-S	1	Kit, Valve Cover-Plain (Includes 2-4)
2	M-651030-S	4	Screw-Hex. Flange, M6x1.0x30
3	24 112 08-S	4	Spacer
4	24 153 23-S	1	O-Ring
5	24 445 01-S	1	Strap-Lifting
6	12 755 03-S	4	Kit, Retainer
7	12 173 01-S	4	Cap-Valve Spring
8	24 089 02-S	4	Spring-Valve
9	235011-S	4	Retainer-Spring
10	66 032 05-S	4	Seal-Valve Stem
11	24 318 65-S	1	#1 Cylinder Head ASM
12	24 017 01-S	2	Valve-Intake (Std.)
13	24 017 02-S	2	Valve-Intake (.25)
14	24 016 01-S	2	Valve-Exhaust (Std.)
15	24 016 02-S	2	Valve-Exhaust (.25)
16	24 605 01-S	1	Liner, Exhaust Port
17	24 755 66-S	1	Kit, Valve Train (Includes 17,20,21)
18	25 351 01-S	4	Lifter-Valve
19	24 411 05-S	4	Rod-Push
20	24 041 37-S	2	Gasket, Cylinder Head
21	24 318 66-S	1	#2 Cylinder Head ASM
22	25 186 01-S	4	Arm-Rocker

Ref	Part No.	Qty.	Description
21	24 599 01-S	2	Pivot-Rocker Arm
22	24 072 09-S	8	Stud-Cylinder Hd., M8x1.25x20, M10x1.5x90, 105mm Long
23	24 468 16-S	8	Washer-Flat
24	24 100 10-S	8	Nut-Hex. Flange, M8x1.25
25	M-640034-S	4	Screw, Hex. Flange M6x1.0x34
26	24 755 75-S	1	Kit, Valve Cover-Oil Fill (Includes 2-4)
27	24 755 46-S	1	Kit, Oil Fill Cap (Includes 28)
28	25 153 02-S	1	O-Ring
29	12 445 05-S	1	Strap-Lifting
30	24 402 03-S	1	Reed-Breather
31	66 018 04-S	1	Retainer-Breather Reed
32	M-545010-S	1	Screw-Hex. Flange, M5x0.8x10
33	24 050 01-S	1	Filter-Breather
34	24 033 01-S	1	Kit, Breather (Includes 35,36)
35	24 041 50-S	1	Gasket, Breather
36	24 096 86-S	1	Cover-Breather
37	M-645020-S	4	Screw-Hex. Flange, M6x1.0x20
38	24 326 68-S	1	Hose, Breather
39	25 452 01-S	1	Terminal

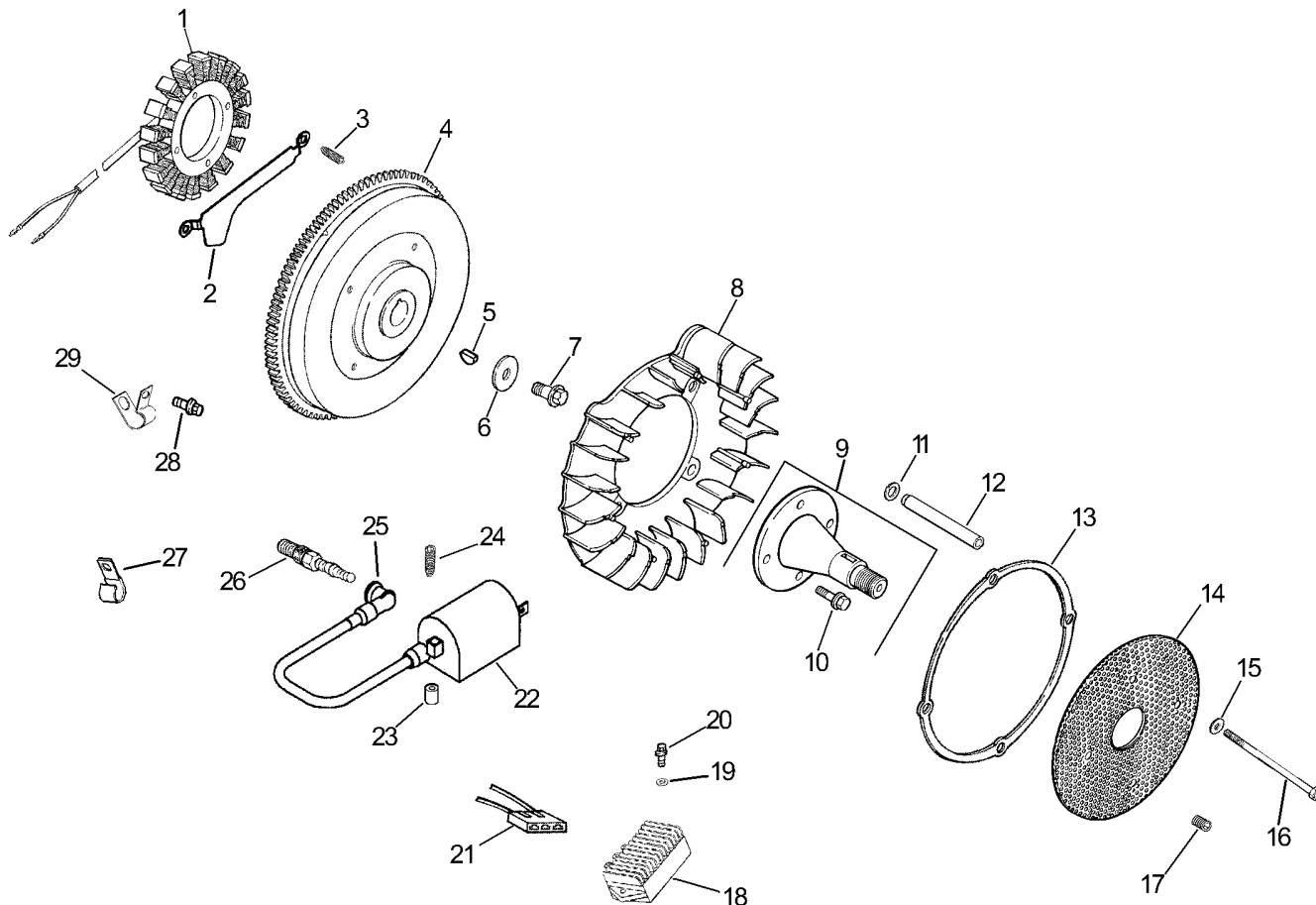

Ignition/Electrical Assembly Kohler CH745-0003

Ref	Part No.	Qty.	Description
1	28 085 02-S	1	Kit, Stator W/connectors (Includes 2,40)
2	25 086 29-S	2	Screw, Tapping 10-24x1in
3	24 126 71-S	1	Bracket-Stator Wire
4	24 025 09-S	1	Flywheel
5	X-42-15-S	1	Key
6	12 468 03-S	1	Washer-Plain, 3/8in
7	12 086 14-S	1	Screw-Hex. Flange, M10x1.5x46
8	24 157 04-S	1	Fan
14	24 755 08-S	1	Kit, Front Drive Shaft (Includes 10)
10	M-839025-S	4	Screw, Hex. Flange M8x1.25x25
11	24 468 11-S	4	Washer, Spring
12	24 112 14-S	4	Spacer
13	24 141 06-S	2	Ring, Support
14	24 162 22-S	1	Screen, Grass
15	X-25-53-S	4	Washer, Plain 1/4in
16	M-603100-S	4	Screw, Hex. Hd. M6x1.0x100
17	25 086 43-S	1	Screw, Set
18	25 403 05-S	1	Rectifier-Regulator 25 Amp
19	X-25-92-S	2	Washer-Plain 3/16
20	24 086 18-S	1	Screw-Phillips Hd., 11-16x7/8
21	236602-S	1	Connector Rectifier-Regulator (3 Contact)
22	24 519 02-S	2	Coil-Ignition

Ref	Part No.	Qty.	Description
23	24 112 16-S	4	Spacer
24	24 086 48-S	4	Screw, Tapping
25	24 131 02-S	1	Spark Plug Boot ASM
26	12 132 06-S	2	Plug-Spark
27	48 154 02-S	1	Clip-Cable (B+ Lead)
28	M-545016-S	1	Screw-Hex. Flange, M5x0.8x16
29	25 237 06-S	1	Clamp-Hose
10	24 100 01-S	2	Nut-Plastic
10	24 518 12-S	1	Lead, Black (6in – 12 Gauge – Insulated Grip Barrel)
10	X-22-11-S	1	Washer, Lock 1/4in (Used To Ground Rectifier-Regulator)
10	12 454 03-S	1	Tie, Wire

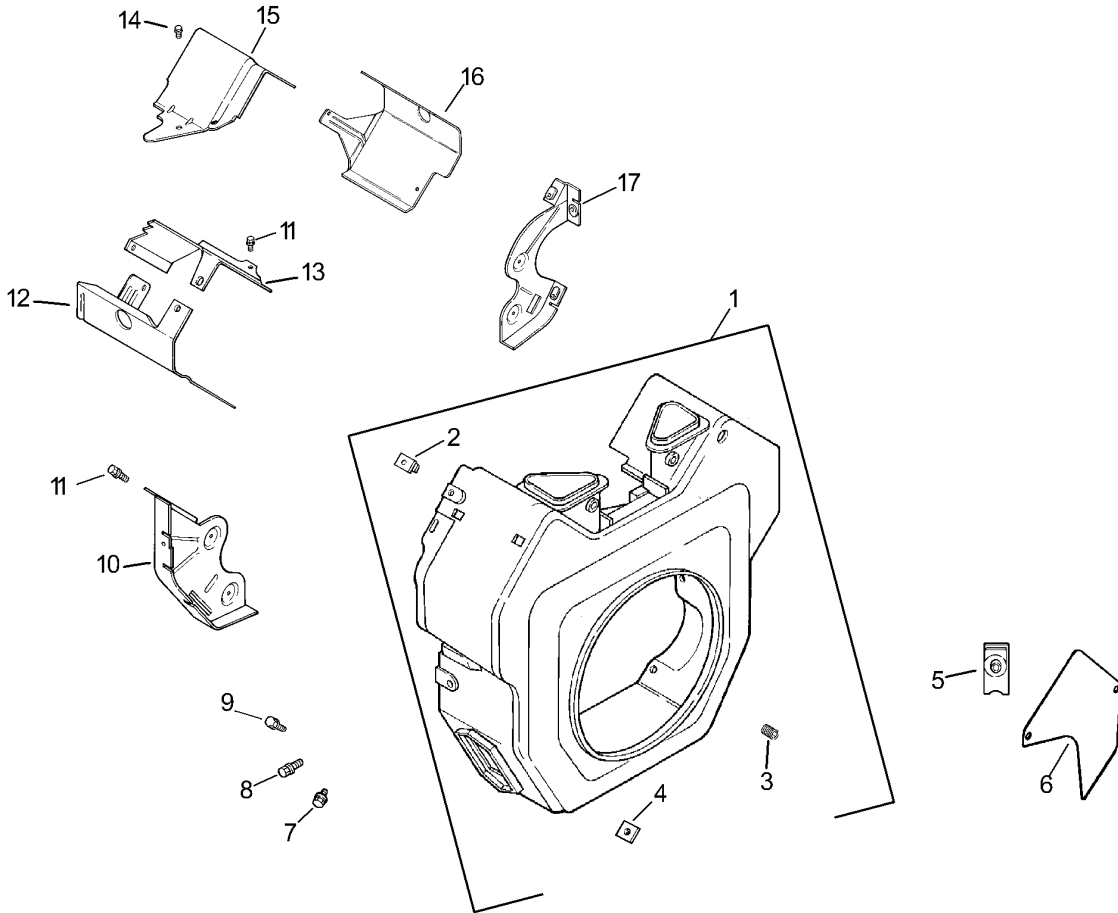

Blower Housing and Baffle Assembly Kohler CH745-0003

Ref	Part No.	Qty.	Description
1	24 027 167-S	1	Housing, Blower (Includes 2-5)
2	24 100 02-S	1	Nut-Plastic
3	25 086 43-S	1	Screw, Set
4	24 100 01-S	4	Nut-Plastic
5	25 154 02-S	4	Clip, Mounting
6	24 096 63-S	2	Panel, Access
7	M-551016-S	1	Screw-Hex. Flange, M5x0.8x16
8	M-545016-S	1	Screw-Hex. Flange, M5x0.8x16
9	M-545020-S	1	Screw-Hex. Flange, M5x0.8x20
10	24 146 19-S	1	Plate, Backing-#2 Side
11	M-645016-S	10	Screw-Hex. Flange, M6x1.0x16
12	24 063 39-S	1	Baffle, Cyl. Barrel-#2
13	24 063 17-S	1	Baffle-Valley, #2 Side
14	M-545010-S	2	Screw-Hex. Flange, M5x0.8x10
15	24 063 59-S	1	Baffle-Valley, #1 Side
16	24 063 58-S	1	Baffle-Cylinder Barrel, #1 Side
17	24 146 20-S	1	Plate-Backing, #1 Side
1 3	X-22-11-S*	1	Washer, Lock 1/4"
4			
1 4	M-561016-S	1	Screw-M5
1 4	24 113 125-S	1	Decal, 26 Hp

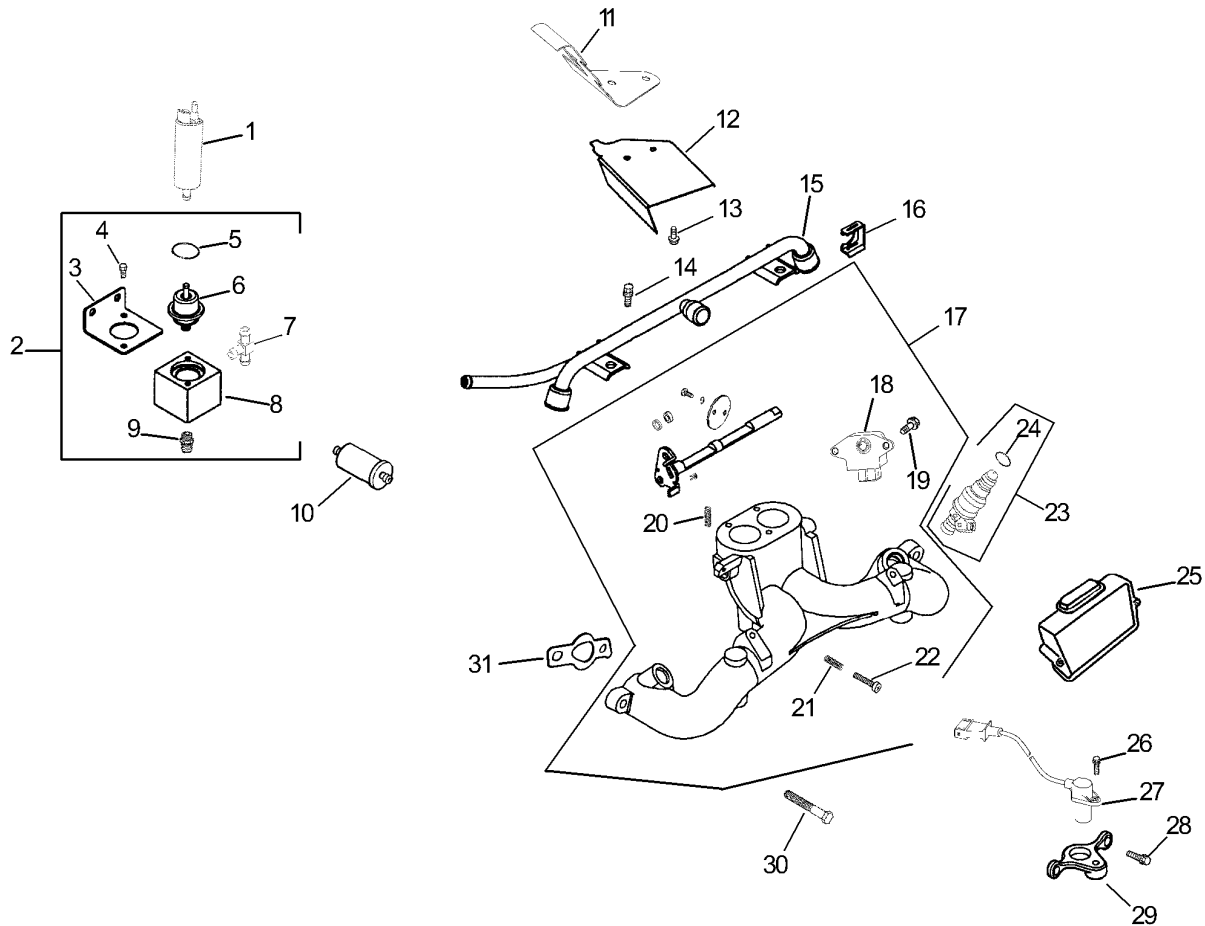

Fuel System Assembly Kohler CH745-0003

Ref	Part No.	Qty.	Description
❶	24 393 20-S	1	Pump Assembly, Fuel(Includes 24 050 06-S)
❷	24 403 12-S	1	Regulator Assembly, Fuel Pressure (Includes 3-9)
❸	24 126 86-S	1	Bracket-Regulator, horizontal
❹	M-410010-S	2	Screw-HH
❺	24 153 18-S	1	O-Ring
❻	24 403 02-S	1	Regulator-Pressure
❼	24 294 15-S	1	Fitting-Tee
❽	24 081 12-S	1	Housing-Regulator, horizontal
❾	25 326 03-S	1	Connector, Straight Hose
❿	24 050 03-S	1	Filter-Fuel
⓫	24 063 37-S	1	Baffle-Valley
⓬	24 265 08-S	1	Deflector-Air
⓭	M-545010-S	2	Screw-Hex. Flange, M5x0.8x10
⓮	M-639010-S	1	Screw-HF
⓯	24 399 04-S	1	Rail-Fuel
⓰	24 154 05-S	2	Clip, Fuel Injector
⓱	24 164 84-S	1	Manifold Assembly, Intake (Includes 18-22 & 25 454 03-S)
⓲	24 418 06-S	1	Sensor-Position, throttle
⓳	M-442012-S	2	Screw, Pan Head
⓴	24 086 49-S	1	Screw, Set
⓵	12 089 11-S	1	Spring, Speed Control
⓶	M-442025-S	1	Screw-HH

Ref	Part No.	Qty.	Description
⓷	24 331 02-S	2	Injector, Fuel (Includes 24)
⓸	24 153 26-S	2	O-Ring, Fuel Injector
⓹	24 584 29-S	1	Control Unit, Electronic (Ecu)
⓺	24 086 42-S	1	Screw-HF
⓻	24 418 03-S	1	Sensor, Engine Speed
⓼	M-545016-S	1	Screw-Hex. Flange, M5x0.8x16
⓽	24 126 69-S	1	Bracket-Sensor, speed
⓾	M-639025-S	4	Screw-HF
⓿	24 041 01-S	2	Gasket-Intake Manifold
⓿	24 755 129-S	1	Kit, Fuel Pump Rebuild (Includes 33,34)
⓿	X-22-5-S	1	Washer, Lock
⓿	24 176 117-S	1	Harness, Wiring(Includes 24 404 02-S)
⓿	24 404 02-S	1	Relay, Mini
⓿	25 454 04-S	1	Tie, Wire
⓿	24 113 78-S	1	Decal, Fuel Warning

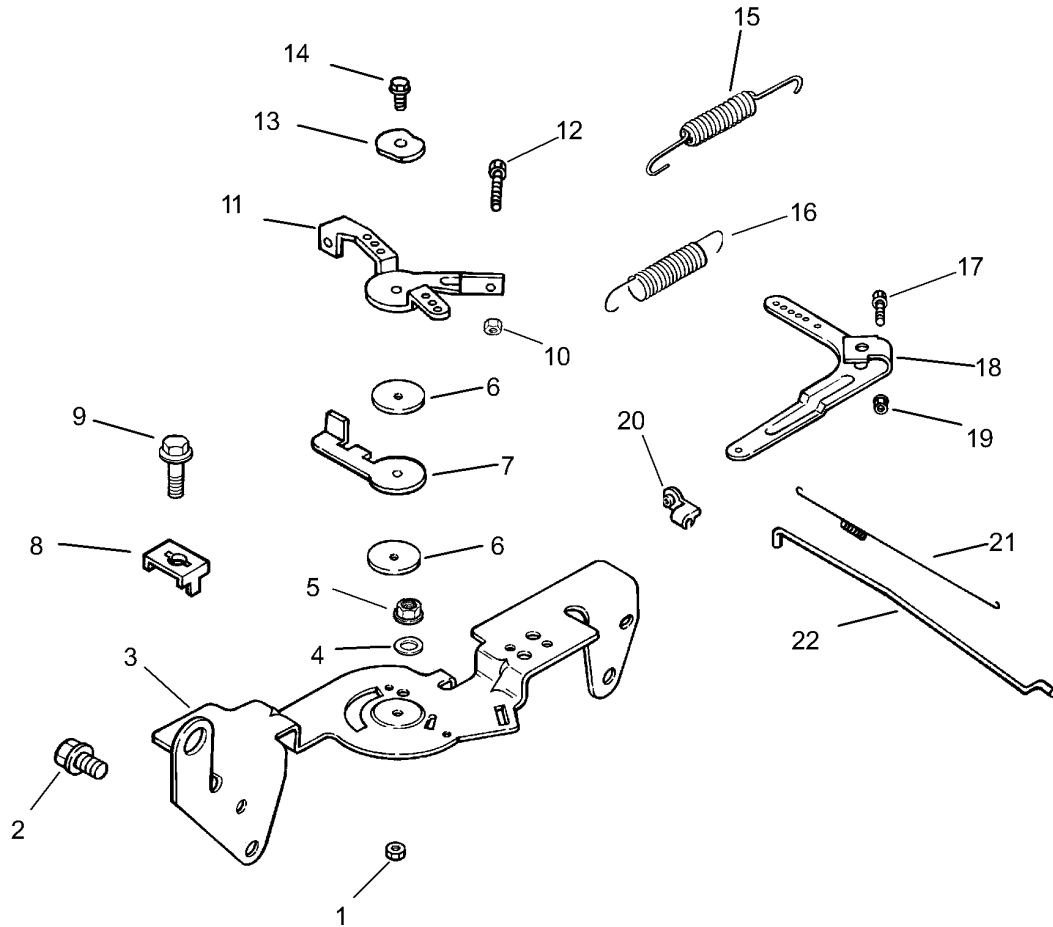

Engine Control Assembly Kohler CH745-0003

Ref	Part No.	Qty.	Description
①	M-547050-S	1	Nut-Hex. Lock, M5x0.8
②	M-645016-S	4	Screw-Hex. Flange, M6x1.0x16
③	24 126 56-S	1	Bracket-Control
④	X-20-1-S	1	Washer-Lock, 1/4
⑤	M-541050-S	1	Nut-Hex. Flange, M5x0.8x50
⑥	24 468 01-S	2	Washer-Plain, 5.5mm
⑦	24 090 07-S	1	Lever-Throttle Actuator
⑧	12 237 01-S	1	Clamp-Cable
⑨	M-545016-S	2	Screw-Hex. Flange, M5x0.8x16
⑩	M-446030-S	1	Nut-Hex, M4x0.7
⑪	24 090 03-S	1	Lever, Throttle Control
⑫	M-401030-S	1	Screw-Hex. Cap, M4x0.7x30
⑬	41 468 03-S	1	Washer-Spring, 1/4
⑭	M-545020-S	1	Screw-Hex. Flange, M5x0.8x20
⑮	24 089 51-S	1	Spring-Throttle Limiter
⑯	24 089 48-S	1	Spring-Governor
⑰	24 211 03-S	1	Bolt-Rd. Hd. Sq. Neck, M6x1.0x16
⑱	24 090 33-S	1	Lever-Governor
⑲	M-641060-S	1	Nut-Hex. Flange, M6x1.0
⑳	25 158 11-S	1	Bushing-Linkage Retaining
㉑	24 089 32-S	1	Spring-Linkage
㉒	24 079 13-S	1	Linkage-Throttle

--	--	--	--

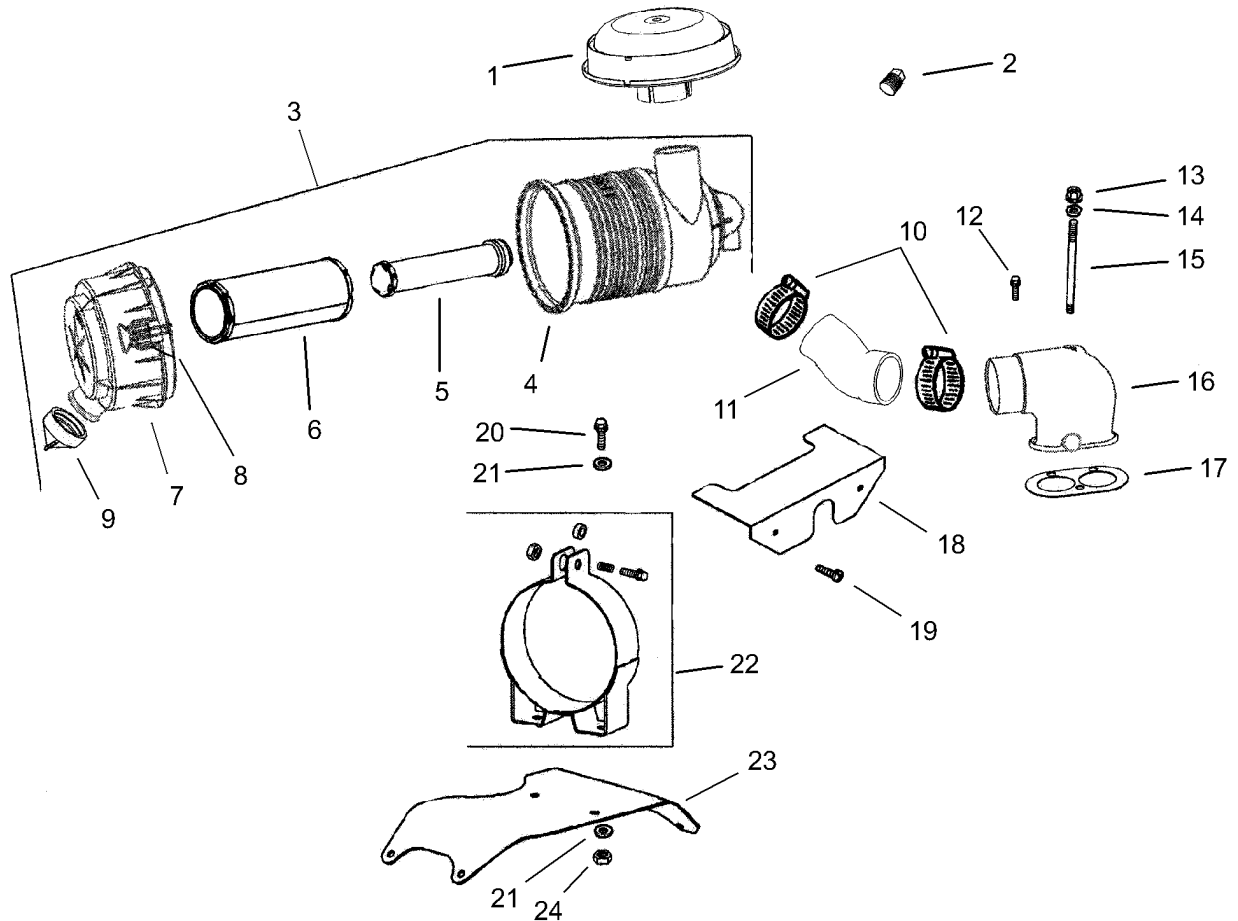

Air Intake/Filtration Assembly Kohler CH745-0003

Ref	Part No.	Qty.	Description
1	25 126 02-S	1	Air Cleaner Bracketasm,
2	25 139 20-S	1	Plug, Pipe
3	25 048 07-S	1	Cleaner Assembly, Heavy-Duty Air (Includes 4-9)
4	25 081 01-S	1	Housing, Heavy Duty Aircleaner
5	25 083 04-S	1	Element, Air-Safety
6	25 083 01-S	1	Element, Air-Primary
7	25 096 06-S	1	Cover Assembly, Heavy-Duty Air (Includes 8,9)
8	25 154 02-S	2	Clip, Mounting
9	24 462 07-S	1	Valve, Dust Ejector
10	25 237 07-S	2	Clamp, Hose
11	24 326 32-S	1	Hose, Air Cleaner
12	M-644025-S	2	Screw-HSH
13	M-641060-S	2	Nut-Hex. Flange, M6x1.0
14	25 468 01-S	1	Washer-Copper
15	M-629122-S	1	Stud-Carburetor
16	24 029 28-S	1	Adapter, Air Intake
17	24 041 36-S	1	Gasket-Base, Aircleaner
18	24 314 28-S	1	Shield, Debris
19	24 086 06-S	2	Screw
20	M-639016-S	2	Screw, Hex. Flange M6x1.0x16
21	X-25-73-S	1	Washer-Plain
22	25 126 02-S	1	Air Cleaner Bracketasm,

Ref	Part No.	Qty.	Description
23	24 126 98-S	1	Bracket, Air Cleaner
24	M-647060-S	1	Nut, Hex Lock
24	24 113 14-S	1	Decal-Maintenance,engine

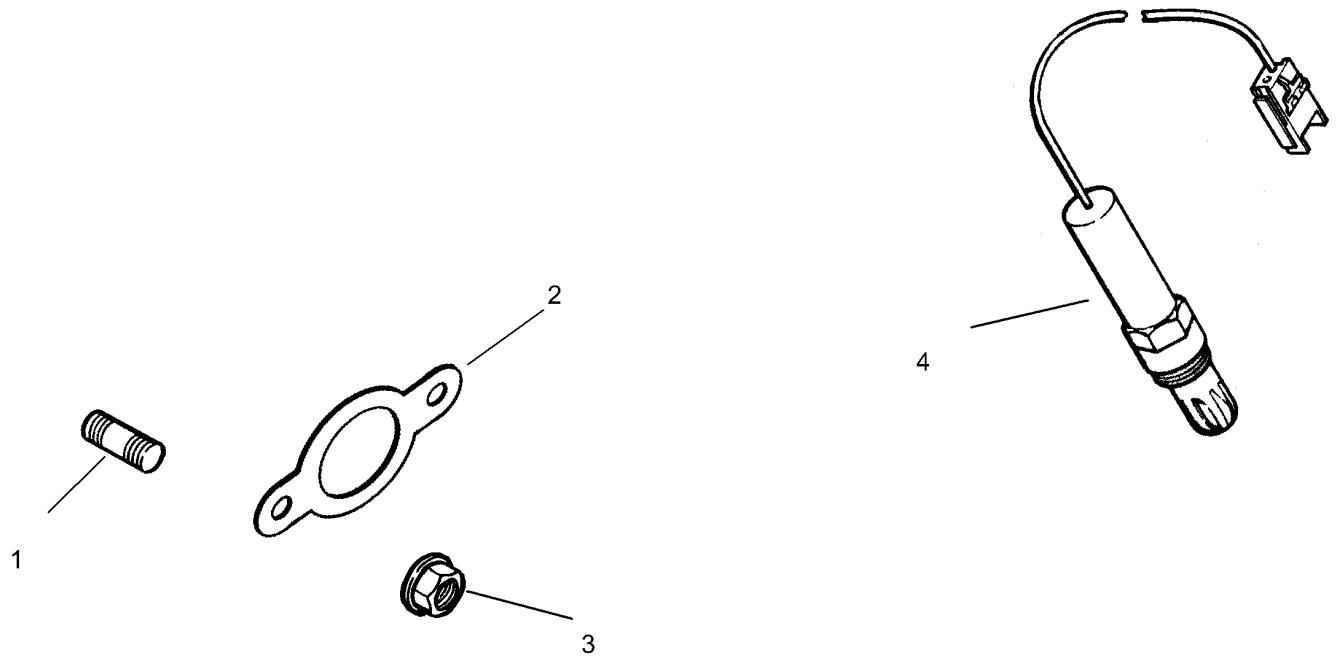

Exhaust Assembly Kohler CH745-0003

Ref	Part No.	Qty.	Description
④1	25 072 04-S	4	Stud-M8x1.25x33
④2	24 041 49-S	2	Gasket-Exhaust
④3	M-841080-S	4	Nut-Hex. Flange, M8x1.25
④4	24 418 05-S	1	Sensor-Oxygen
①④	24 782 36	1	Miniblock
①④	24 755 109-S	1	Gasket Set

--	--	--	--

NOTES

