



Z453 Z Master[®]

**With 48in or 52in TURBO FORCE
Side Discharge Mower**

Model No. 74416—Serial No. 250000001 and Up

Model No. 74417—Serial No. 250000001 and Up

PROTOTYPE

Operator's Manual



Warning



CALIFORNIA

Proposition 65 Warning

The engine exhaust from this product contains chemicals known to the State of California to cause cancer, birth defects, or other reproductive harm.

Important This engine is not equipped with a spark arrester muffler. It is a violation of California Public Resource Code Section 4442 to use or operate this engine on any forest-covered, brush-covered, or grass-covered land. Other states or federal areas may have similar laws.

This spark ignition system complies with Canadian ICES-002.

Ce système d'allumage par étincelle de véhicule est conforme à la norme NMB-002 du Canada.

The enclosed Engine Owner's Manual is supplied for information regarding The U.S. Environmental Protection Agency (EPA) and the California Emission Control Regulation of emission systems, maintenance and warranty.

Keep this engine Owner's Manual with your unit. Should this engine Owner's Manual become damaged or illegible, replace immediately. Replacements may be ordered through the engine manufacturer.

Contents

	Page
Introduction	3
Safety	3
Safe Operating Practices	3
Slope Chart	7
Safety and Instruction Decals	9
Gasoline and Oil	14
Recommended Gasoline	14
Using a Fuel Stabilizer/Conditioner	14
Filling the Fuel Tank	14
Checking the Engine Oil Level	14
Operation	15
Using the Rollover Protection System (ROPS) ...	15
Think Safety First	16
Controls	17
Operating the Parking Brake	17
Starting and Stopping the Engine	18
Operating the Power Takeoff (PTO)	19
The Safety Interlock System	19

	Page
Driving Forward or Backward	20
Stopping the Machine	20
Adjusting the Height-of-Cut	21
Adjusting the Anti-scalp Rollers	21
Positioning the Seat	22
Pushing the Machine by Hand	22
Operating with the Side Discharge	23
Transporting the Machine	23
Loading the Machines	23
Tips for Mowing Grass	24
Maintenance	25
Recommended Maintenance Schedule	25
Servicing the Cutting Blades	26
Cleaning the Cooling System	28
Servicing the Air Cleaner	29
Servicing the Engine Oil	30
Servicing the Spark Plug(s)	31
Replacing the Fuel Filter	32
Draining the Fuel Tank	32
Greasing and Lubrication	33
Checking the Tire Pressure	34
Servicing the Hydraulic System	34
Waste Disposal	36
Adjusting the Handle Neutral Position	36
Setting the Hydraulic Pump Neutral Position ...	37
Adjusting the Tracking	38
Adjusting the Caster Pivot Bearing	38
Checking the Wheel Hub Slotted Nut	39
Leveling the Mower at Three Positions	39
Adjusting the Push Arms	41
Cleaning Under the Mower	41
Inspecting the Belts	42
Replacing the Mower Belt	42
Replacing the Pump Drive Belt	43
Adjusting the Parking Brake	43
Servicing the Fuses	44
Servicing the Battery	44
Replacing the Grass Deflector	47
Waste Disposal	47
Wiring Diagram	48
Cleaning and Storage	49
Troubleshooting	50
The Toro Total Coverage Guarantee	52

Introduction

Read this manual carefully to learn how to operate and maintain your product properly. The information in this manual can help you and others avoid injury and product damage. Although Toro designs and produces safe products, you are responsible for operating the product properly and safely.

You may contact Toro directly at www.Toro.com for product and accessory information, help finding a dealer, or to register your product.

Whenever you need service, genuine Toro parts, or additional information, contact an Authorized Service Dealer or Toro Customer Service and have the model and serial numbers of your product ready. Figure 1 illustrates the location of the model and serial numbers on the product.

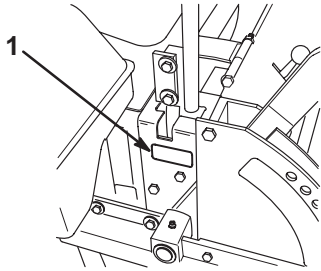

m-3648

Figure 1

1. Location of the model and serial numbers

Write the product model and serial numbers in the space below:

Model No. _____
Serial No. _____

This manual identifies potential hazards and has special safety messages that help you and others avoid personal injury and even death. **Danger**, **Warning**, and **Caution** are signal words used to identify the level of hazard. However, regardless of the hazard, be extremely careful.

Danger signals an extreme hazard that **will** cause serious injury or death if you do not follow the recommended precautions.

Warning signals a hazard that **may** cause serious injury or death if you do not follow the recommended precautions.

Caution signals a hazard that may cause minor or moderate injury if you do not follow the recommended precautions.

This manual uses 2 other words to highlight information.

Important calls attention to special mechanical information and **Note**: emphasizes general information worthy of special attention.

Safety

Improper use or maintenance by the operator or owner can result in injury. To reduce the potential for injury, comply with these safety instructions and always pay attention to the safety alert symbol, which means CAUTION, WARNING, or DANGER—“personal safety instruction.” Failure to comply with the instruction may result in personal injury or death.

This product is capable of amputating hands and feet and throwing objects. Always follow all safety instructions to avoid serious injury or death.

This product is designed for cutting and recycling grass or, when equipped with a grass bagger, for catching cut grass. Any use for purposes other than these could prove dangerous to user and bystanders.

Safe Operating Practices

The following instructions are from ANSI standard B71.4—2004.

Training

- Read the Operator’s Manual and other training material. If the operator(s) or mechanic(s) can not read English it is the owner’s responsibility to explain this material to them.
- Become familiar with the safe operation of the equipment, operator controls, and safety signs.
- All operators and mechanics should be trained. The owner is responsible for training the users.
- Never let children or untrained people operate or service the equipment. Local regulations may restrict the age of the operator.
- The owner/user can prevent and is responsible for accidents or injuries occurring to himself or herself, other people or property.

Preparation

- Evaluate the terrain to determine what accessories and attachments are needed to properly and safely perform the job. Only use accessories and attachments approved by the manufacturer.
- Wear appropriate clothing including hard hat, safety glasses and hearing protection. Long hair, loose clothing or jewelry may get tangled in moving parts.

- Inspect the area where the equipment is to be used and remove all objects such as rocks, toys and wire which can be thrown by the machine.
- Use extra care when handling gasoline and other fuels. They are flammable and vapors are explosive.
 - Use only an approved container
 - Never remove gas cap or add fuel with engine running. Allow engine to cool before refueling. Do not smoke.
 - Never refuel or drain the machine indoors.
- Check that operator's presence controls, safety switches and shields are attached and functioning properly. Do not operate unless they are functioning properly.

Operation

- Never run an engine in an enclosed area.
- Only operate in good light, keeping away from holes and hidden hazards.
- Be sure all drives are in neutral and parking brake is engaged before starting engine. Start the engine only from the operator's position.
- Never raise deck with the blades running.
- Never operate without the PTO shield, or other guards securely in place. Be sure all interlocks are functioning properly.
- Never operate with the discharge deflector raised, removed or altered, unless using a grass catcher.
- Do not change the engine governor setting or overspeed the engine.
- Stop on level ground, lower implements, disengage drives, engage parking brake, shut off engine before leaving the operator's position for any reason including emptying the catchers or unclogging the chute.
- Stop equipment and inspect blades after striking objects or if an abnormal vibration occurs. Make necessary repairs before resuming operations.
- Keep hands and feet away from the cutting units.
- Never carry passengers and keep pets and bystanders away.
- Be alert, slow down and use caution when making turns. Look behind and to the side before changing directions.
- Slow down and use caution when crossing roads and sidewalks. Stop blades if not mowing.
- Be aware of the mower discharge direction and do not point it at anyone.
- Do not operate the mower under the influence of alcohol or drugs.
- Use extreme care when loading or unloading the machine into a trailer or truck.
- Use care when approaching blind corners, shrubs, trees, or other objects that may obscure vision.

Slope Operation

- Do not mow slopes greater than 15 degrees.
- Do not mow near drop-offs, ditches, steep banks or water. Wheels dropping over edges can cause rollovers, which may result in serious injury, death or drowning.
- Do not mow slopes when grass is wet. Slippery conditions reduce traction and could cause sliding and loss of control.
- Do not make sudden turns or rapid speed changes.
- Use a walk behind mower and/or a hand trimmer near drop-offs, ditches, steep banks or water.
- Reduce speed and use extreme caution on slopes.
- Remove or mark obstacles such as rocks, tree limbs, etc. from the mowing area. Tall grass can hide obstacles.
- Watch for ditches, holes, rocks, dips, and rises that change the operating angle, as rough terrain could overturn the machine.
- Avoid sudden starts when mowing uphill because the mower may tip backwards.
- Be aware that loss of traction may occur going downhill. Weight transfer to the front wheels may cause drive wheels to slip and cause loss of braking and steering.
- Always avoid sudden starting or stopping on a slope. If tires lose traction, disengage the blades and proceed slowly off the slope.
- Follow the manufacturer's recommendations for wheel weights or counterweights to improve stability.
- Use extreme care with grass catchers or other attachments. These can change the stability of the machine and cause loss of control.

Using the Rollover Protection System (ROPS)

- Keep the roll bar in the raised and locked position and use the seat belt when operating the machine.
 - Be certain that the seat belt can be released quickly in the event of an emergency.
 - Be aware there is no rollover protection when the roll bar is down.
 - Check the area to be mowed and never fold the ROPS in areas where there are slopes, drop offs or water.
 - Lower the roll bar only when absolutely necessary. Do not wear the seat belt with the roll bar folded down.
 - Check carefully for overhead clearances (i.e. branches, doorways, electrical wires) before driving under any objects and do not contact them.
- Keep all parts in good working condition and all hardware tightened. Replace all worn or damaged decals.
 - Use only Toro-approved attachments. Warranty may be voided if used with unapproved attachments.

Maintenance and storage

- Disengage drives, lower implement, set parking brake, stop engine and remove key or disconnect spark plug wire. Wait for all movement to stop before adjusting, cleaning or repairing.
- Clean grass and debris from cutting units, drives, mufflers, and engine to help prevent fires. Clean up oil or fuel spillage.
- Let engine cool before storing and do not store near flame.
- Shut off fuel while storing or transporting. Do not store fuel near flames or drain indoors.
- Park machine on level ground. Never allow untrained personnel to service machine.
- Use jack stands to support components when required.
- Carefully release pressure from components with stored energy.
- Disconnect battery or remove spark plug wire before making any repairs. Disconnect the negative terminal first and the positive last. Reconnect positive first and negative last.
- Use care when checking blades. Wrap the blade(s) or wear gloves, and use caution when servicing them. Only replace blades. Never straighten or weld them.
- Keep hands and feet away from moving parts. If possible, do not make adjustments with the engine running.
- Charge batteries in an open well ventilated area, away from spark and flames. Unplug charger before connecting or disconnecting from battery. Wear protective clothing and use insulated tools.

PROTOTYPE

PROTOTYPE

Slope Chart

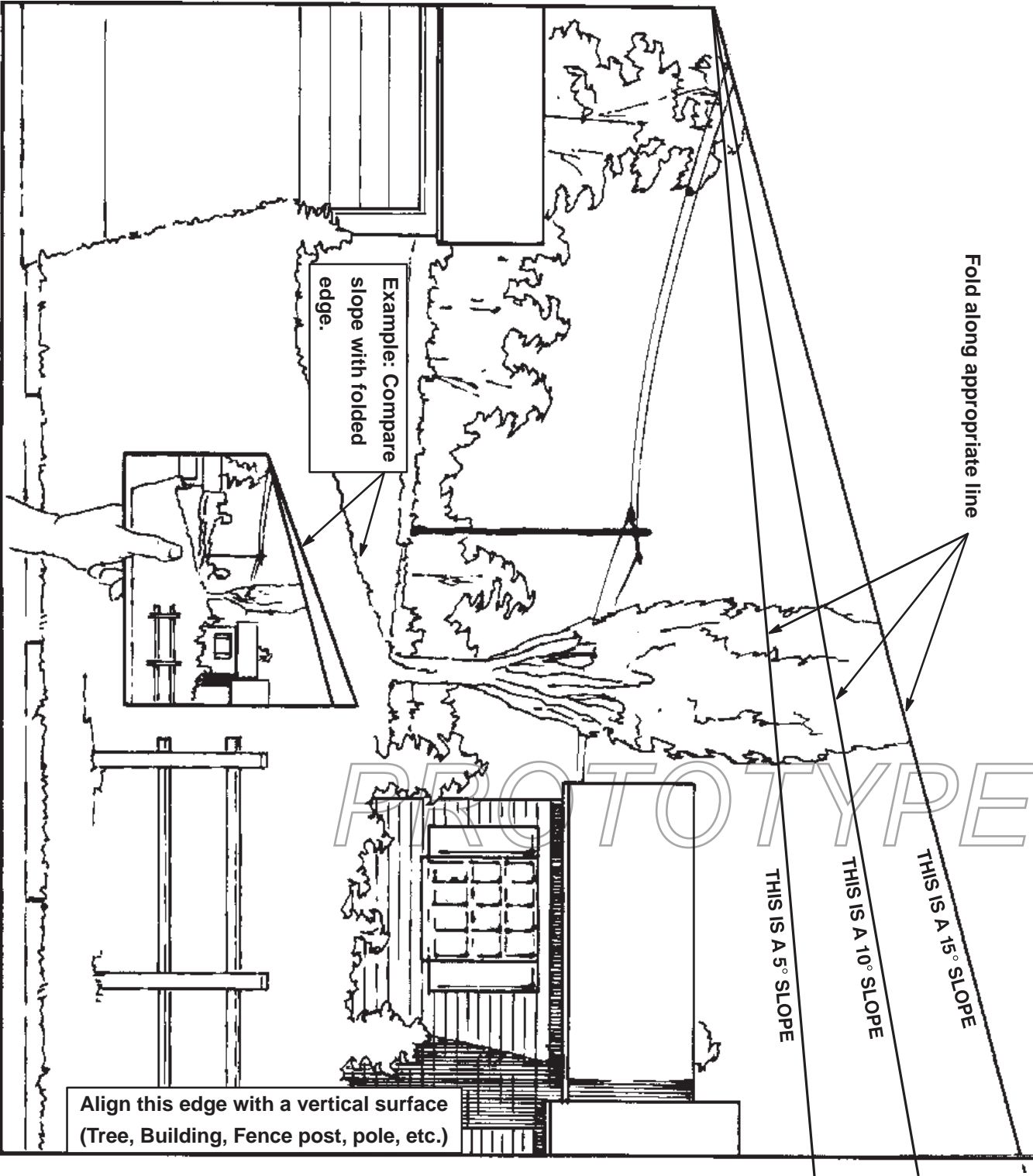

PROTOTYPE

Safety and Instruction Decals



Safety decals and instructions are easily visible to the operator and are located near any area of potential danger. Replace any decal that is damaged or lost.



1-523552



58-6520

1. Grease

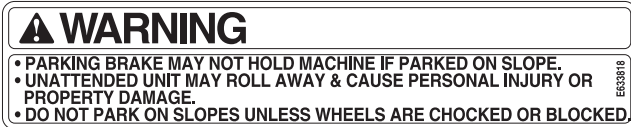

1-633818



65-2690



43-8480



66-1340



54-9220

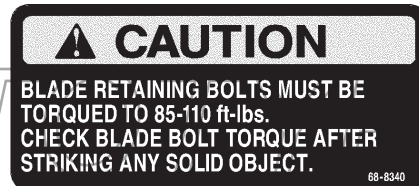

68-8340



98-4387

1. Warning—wear hearing protection.



98-5954



103-1997



103-2644



107-1613



104-8569

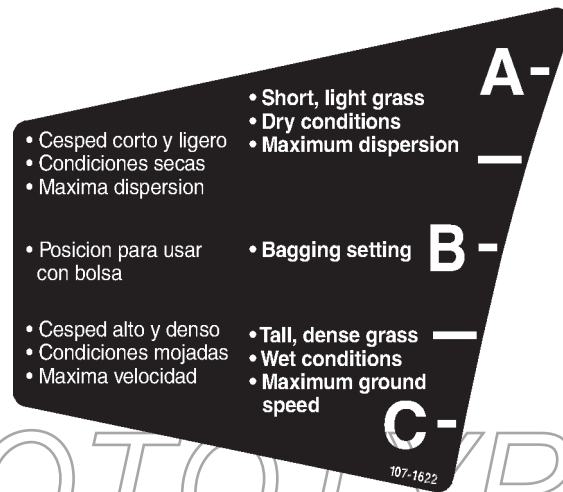

107-1622

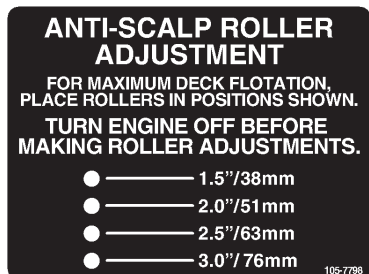

105-7798

SERVICE AID AND BELT ROUTING

Every 10 hours (daily):

1. Check engine oil

Every 50 hours:

2. Check hydraulic oil
3. Check tire pressure—13 psi
4. Grease blade spindle bearings
5. Grease front wheel bearings
6. Grease deck lift linkage
7. Grease belt idler

Every 250 hours:

8. Grease brake linkage
9. Inspect belt and tension
10. Grease belt idler

Every 1000 hours (yearly):

11. Inspect covers and safety systems
12. Inspect fasteners and hoses
13. Grease front caster pivot

See operator's manual for additional details.

107-1687

- A

- Short, light grass
- Dry conditions
- Maximum dispersion

- B

- Bagging setting

- C

- Tall, dense grass
- Wet conditions
- Maximum ground speed

Césped corto y ligero
Condiciones secas
Maxima dispersion

Posicion para usar con bolsa

Césped alto y denso
Condiciones mojadas
Maxima velocidad

107-1688

107-1688

TORO THE TORO COMPANY
8111 LYNDALE AVE. S.
BLOOMINGTON, MN 55420

**FITS: ALL Z MASTER Z100
AND Z400 SERIES
MID-MOUNT ZRTS**

MEETS OSHA 1928.51 (B) (1)

107-2100

107-2100

WARNING

TO AVOID INJURY OR DEATH FROM ROLLOVER:

Keep roll bar in the raised and locked position and use seat belt.

THERE IS NO ROLL OVER PROTECTION WHEN THE ROLL BAR IS DOWN.

Lower the roll bar only when absolutely necessary.

Do not wear seat belt when the roll bar is down.

Drive slowly and carefully.

Raise the roll bar as soon as clearance permits.

Read and follow slope operation instructions and warnings.

107-2102

107-2102

⚠ WARNING

- Operating on wet grass or steep slopes can cause sliding and loss of control.
- Wheels dropping over edges can cause rollovers, which may result in serious injury, death or drowning.
- To avoid loss of control and possibility of rollover:
 - Do NOT operate near drop-offs or near water.
 - Do NOT operate on slopes greater than 15°.
 - Reduce speed and use extreme caution on slopes.
 - Avoid sudden turns or rapid speed changes.
- There is no rollover protection when the roll bar is down.
- Always keep roll bar in the raised and locked position and use seat belt.
- Read and follow rollover protection instructions and warning.

107-2112

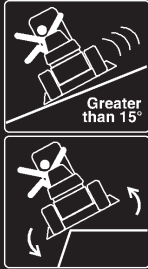

107-2112



107-2148

⚠ WARNING

To avoid serious injury or death:

- Read and understand the operator's manual before using this machine.
- Do not operate unless trained to safely use this machine.
- Do not operate under the influence of alcohol or drugs.
- Do not operate without shields, guards, and safety devices in place and working.
- Check the function of all safety interlocks daily.
- Do not defeat interlocks.
- Hearing protection is recommended.

REQUIREMENT: Before starting engine, clear grass from blade compartment. Check PTO/blade in dry conditions.

For additional manual, send request & serial number to: 504-344-0100, #121, Lombard Ave. 2, Minneapolis, MN 55426

DISENPOWER

↑

↓

ENGAGE

(P)

BRAKE

⚠ DANGER

- Pick up objects that could be thrown by the blades.
- Never mow when bystanders are in the area.
- Never carry passengers.
- Look behind and to the side before changing directions.
- Stop the engine and remove key before adjusting, servicing or cleaning machine and attachments.

Before leaving the operator's -0050s:

- Stop the engine and disengage the blade.
- Move the levers out to the neutral lock position.
- Set the parking brake.
- Avoid blades as long as engine and blades are stopped.

107-8445

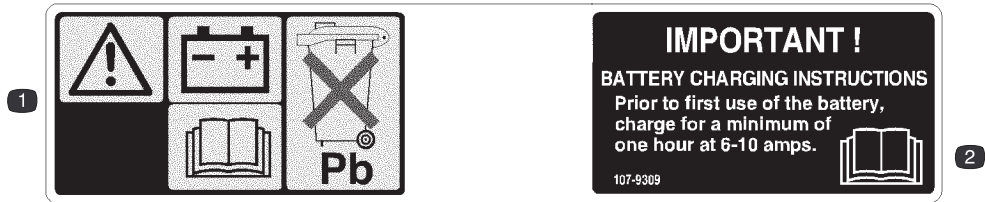

107-9309

1. Warning—read the *Operator's Manual* for information on charging the battery; contains lead; do not discard.
2. Read the *Operator's Manual*.

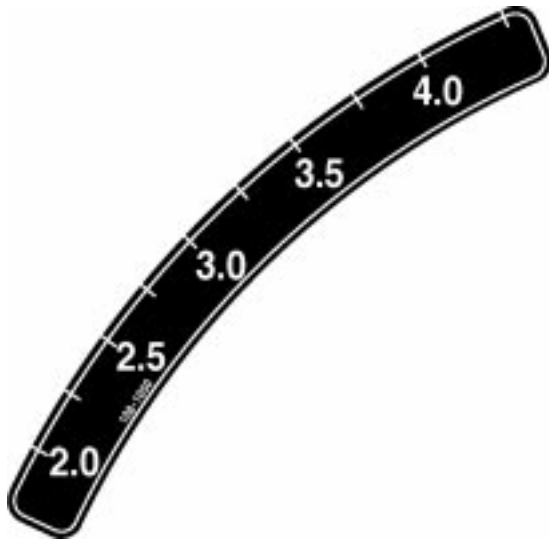

108-1050

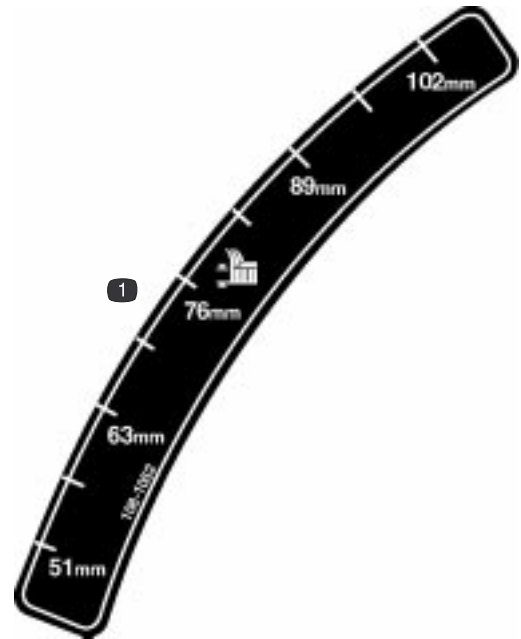

108-1052

1. Height of cut adjustment

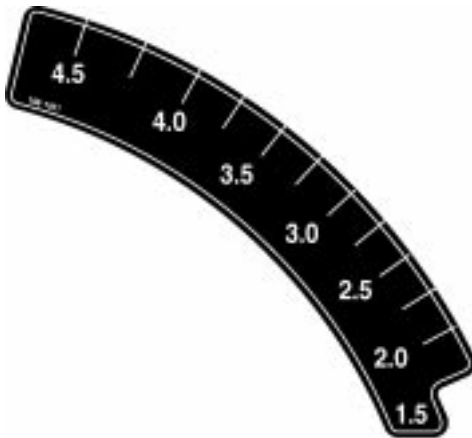

108-1051

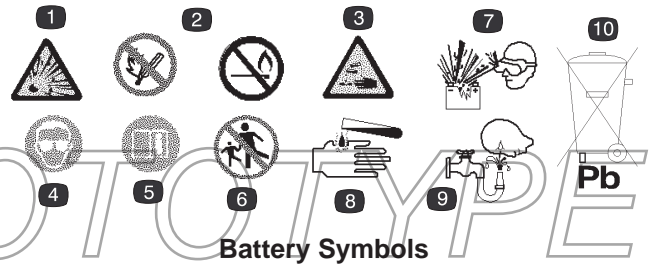

Battery Symbols

Some or all of these symbols are on your battery.

- | | |
|--|---|
| <ol style="list-style-type: none"> 1. Explosion hazard 2. No fire, open flames, or smoking. 3. Caustic liquid/chemical burn hazard 4. Wear eye protection 5. Read the <i>Operator's Manual</i>. 6. Keep bystanders a safe distance from the battery. | <ol style="list-style-type: none"> 7. Wear eye protection; explosive gases can cause blindness and other injuries 8. Battery acid can cause blindness or severe burns. 9. Flush eyes immediately with water and get medical help fast. 10. Contains lead; do not discard. |
|--|---|

Gasoline and Oil

Recommended Gasoline

Use **unleaded regular gasoline** suitable for automotive use (85 pump octane minimum). You may use leaded regular gasoline if unleaded regular is not available.

Important Never use methanol, gasoline containing methanol, or gasohol containing more than 10% ethanol because the fuel system could be damaged. Do not mix oil with gasoline.



Danger



In certain conditions, gasoline is extremely flammable and highly explosive. A fire or explosion from gasoline can burn you and others and can damage property.

- Fill the fuel tank outdoors, in an open area, when the engine is cold. Wipe up any gasoline that spills.
- Never fill the fuel tank inside an enclosed trailer.
- Do not fill the fuel tank completely full. Add gasoline to the fuel tank until the level is 1/4 to 1/2 inch (6 to 13 mm) below the bottom of the filler neck. This empty space in the tank allows gasoline to expand.
- Never smoke when handling gasoline, and stay away from an open flame or where gasoline fumes may be ignited by a spark.
- Store gasoline in an approved container and keep it out of the reach of children. Never buy more than a 30-day supply of gasoline.
- Always place gasoline containers on the ground, away from your vehicle before filling.
- Do not fill gasoline containers inside a vehicle or on a truck or trailer bed because interior carpets or plastic truck bed liners may insulate the container and slow the loss of any static charge.
- When practical, remove gasoline-powered equipment from the truck or trailer and refuel the equipment with its wheels on the ground.
- If this is not possible, then refuel such equipment on a truck or trailer from a portable container rather than from a gasoline dispenser nozzle.
- If you must use a gasoline dispenser nozzle, keep the nozzle in contact with the rim of the fuel tank or container opening at all times until fueling is complete.
- Do not operate the machine without the entire exhaust system in place and in proper working condition.



Warning



Gasoline is harmful or fatal if swallowed. Long-term exposure to vapors can cause serious injury and illness.

- Avoid prolonged breathing of vapors.
- Keep your face away from the nozzle and fuel tank or conditioner opening.
- Keep gasoline away from eyes and skin.

Using a Fuel Stabilizer/Conditioner

Use a fuel stabilizer/conditioner in the machine to provide the following benefits:

- Keeps stored gasoline fresh for 90 days or less; for longer storage, drain the fuel tank.
- Cleans the engine while it runs
- Eliminates gum-like varnish buildup in the fuel system, which causes hard starting

Important Do not use fuel additives containing methanol or ethanol.

Add the correct amount of stabilizer/conditioner to the gasoline.

Note: A fuel stabilizer/conditioner is most effective when it is mixed with fresh gasoline. To minimize the chance of varnish deposits in the fuel system, use fuel stabilizer at all times.

Filling the Fuel Tank

1. Shut the engine off and set the parking brake.
2. Clean around each fuel tank cap and remove the cap. Add unleaded regular gasoline to both fuel tanks until the level is 1/4 to 1/2 inch (6 to 13 mm) below the bottom of the filler neck. This space in the tank allows gasoline to expand. Do not fill the fuel tanks completely full.
3. Install fuel tank caps securely. Wipe up any gasoline that spills.

Checking the Engine Oil Level

Before you start the engine and use the machine, check the oil level in the engine crankcase; refer to Checking the Engine Oil Level on page 30.

Operation

Note: Determine the left and right sides of the machine from the normal operating position.

Using the Rollover Protection System (ROPS)

Warning

To avoid injury or death from a rollover, keep the roll bar in the raised locked position and use the seat belt.

Ensure that the rear part of the seat is secured with the seat latch.

Warning

There is no rollover protection when the roll bar is in the down position.

- Lower the roll bar only when absolutely necessary.
- Do not wear the seat belt when the roll bar is in the down position.
- Drive slowly and carefully.
- Raise the roll bar as soon as clearance permits.
- Check carefully for overhead clearances (e.g., branches, doorways, and electrical wires) before driving under any objects and do not contact them.

Important Lower the roll bar only when absolutely necessary.

1. To lower the roll bar, loosen the front handles (Fig. 2).

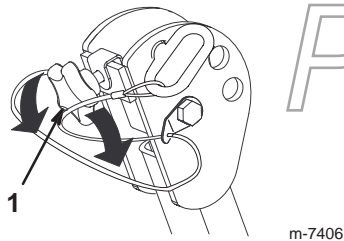

Figure 2

1. Front handle

2. Remove the hairpin cotter pins and remove the 2 pins (Fig. 3).

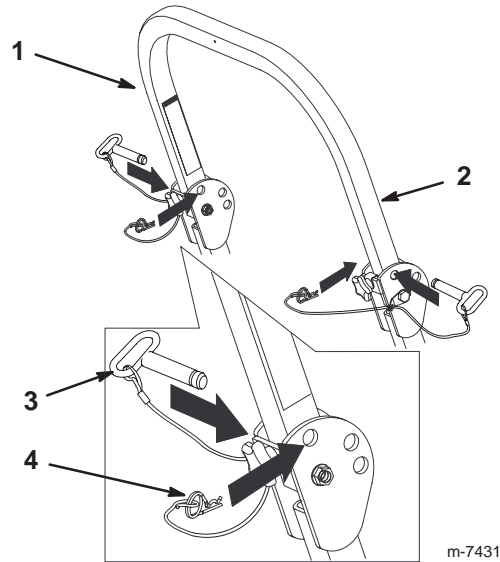

Figure 3

1. Roll bar
2. Raised position
3. Pin
4. Hairpin cotter pin

3. Lower the the roll bar to the down position.

Note: There are 2 down positions. See Figure 4 for the positions.

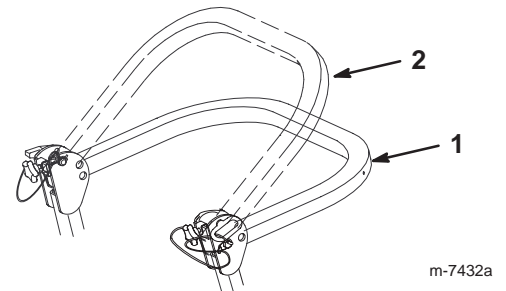

Figure 4

1. Full down position
2. Down position with bagger installed
4. Install the 2 pins and secure them with the hairpin cotter pins (Fig. 3).

Important Always use the seat belt with the roll bar in the raised position.

Important Ensure that the rear part of the seat is secured with the seat latch.

5. To raise the roll bar, remove the hairpin cotter pins and remove the 2 pins (Fig. 3).
6. Raise the roll bar to the upright position and install the 2 pins and secure them with the hairpin cotter pins (Fig. 3).

- Tighten the front handles against the center roll bar ends (Fig. 2).

Think Safety First

Read all safety instructions and symbols in the safety section. Knowing this information could help you or bystanders avoid injury.

! **Danger** !

Operating the machine on wet grass or steep slopes can cause sliding and loss of control.

Wheels dropping over the edges can cause rollovers, which may result in serious injury, death, or drowning.

There is no rollover protection when the roll bar is down.

Always keep the roll bar in the raised and locked position, and use the seat belt.

Read and follow the rollover protection instructions and warnings.

To avoid loss of control and the possibility of rollover:

- **Do not operate the machine near dropoffs or near water.**
- **Do not operate the machine on slopes greater than 15 degrees.**
- **Reduce the speed and use extreme caution on slopes.**
- **Avoid sudden turns or rapid speed changes.**
- **Avoid operating the machine on wet grass.**

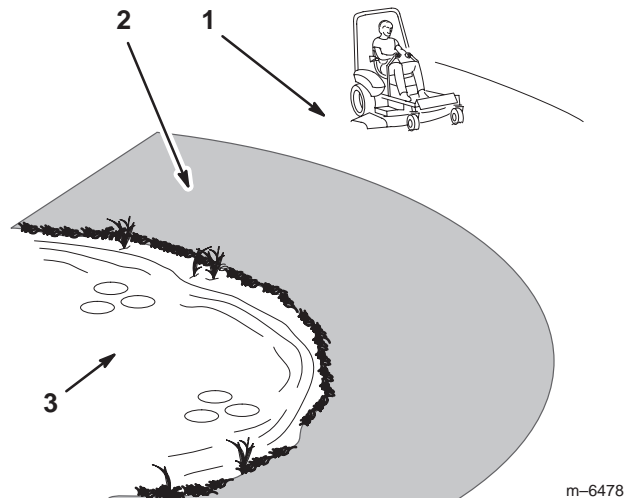

Figure 5

- Safe Zone—use the Z Master here on slopes less than 15 degrees or flat areas.
- Use the walk behind mower or hand trimmer near dropoffs and water.
- Water

m-6478

Toro recommends that you use protective equipment for your eyes, ears, feet, and head.

! **Caution** !

This machine produces sound levels in excess of 85 dBA at the operators ear and can cause hearing loss through extended periods of exposure.

Wear hearing protection when operating this machine.



Figure 6

- Warning—wear hearing protection.

PROTOTYPE

Controls

Become familiar with all the controls (Fig. 7) before you start the engine and operate the machine.

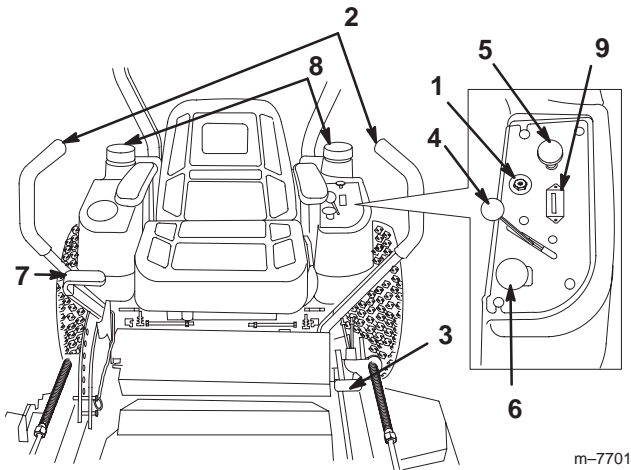

Figure 7

- | | |
|--------------------------|------------------------|
| 1. Ignition switch | 6. Power takeoff (PTO) |
| 2. Motion control levers | 7. Height-of-cut lever |
| 3. Parking brake lever | 8. Fuel caps |
| 4. Throttle | 9. Hourmeter |
| 5. Choke | |

Using the Hour Meter

The hour meter (Fig. 8) records the number of hours the engine has operated. It operates when the engine is running. Use these times for scheduling regular maintenance.

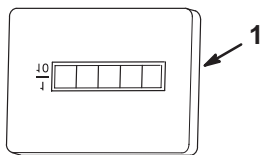

Figure 8

1. Hour meter

Using the Fuel Shutoff Valve

The machine has 2 fuel tanks, one on the left side and the other on the right side. Each tank connects to a check valve and then to a tee. From there a common fuel line leads to the engine (Fig. 9).

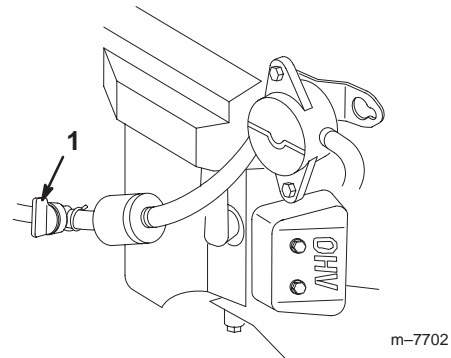

Figure 9

1. Fuel shutoff valve

Close the fuel shutoff valve before transporting or storing the machine.

Operating the Parking Brake

Always set the parking brake when you stop the machine or leave it unattended.

Important Do not park the machine on slopes unless the wheels are chocked or blocked.

Setting the Parking Brake

1. Move the motion control levers (Fig. 10) to the neutral lock position.

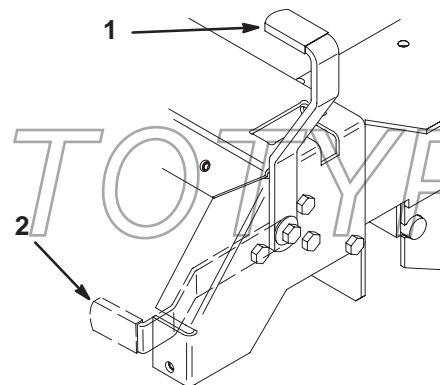

Figure 10

1. Parking brake—On
 2. Parking brake—Off
2. Pull back and up on the parking brake lever to set the parking brake (Fig. 10).

Note: The parking brake lever should stay firmly in the Engaged position.

Releasing the Parking Brake

Push forward and down on the parking brake lever to release the parking brake (Fig. 10).

Starting and Stopping the Engine

Starting the Engine

1. Sit on the seat and move the motion controls to the neutral locked position.
2. Set the parking brake; refer to Setting the Parking Brake on page 17.
3. Move the PTO (power takeoff) to Off (Fig. 11).

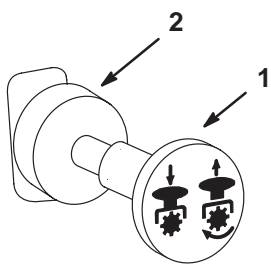

m-4201

Figure 11

1. PTO—On
2. PTO—Off

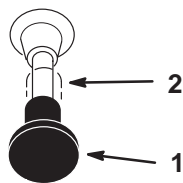

m-2719

Figure 12

1. Choke—On
2. Choke—Off

4. Move the choke control to On before starting a cold engine (Fig. 12).

Note: A warm or hot engine may require choking. After the engine starts, move the choke control to the Off position.

5. Move the throttle control to Fast before starting a cold engine (Fig. 13).

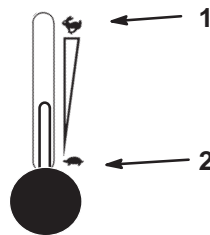

m-2720a

Figure 13

1. Fast
2. Slow

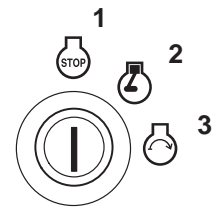

IGNITION

m-4268

Figure 14

1. Off
2. Run
3. Start

6. Turn the ignition key to Start to energize the starter. When the engine starts, release the key (Fig. 14).

Important Do not engage the starter for more than 10 seconds at a time. If the engine fails to start, allow a 30 second cool down period between attempts. Failure to follow these instructions can burn out the starter motor.

7. After the engine starts, move the choke to Off (Fig. 12). If the engine stalls or hesitates, move the choke back to On for a few seconds. Then move the throttle lever to the desired setting. Repeat this step as necessary.

Stopping the Engine

1. Push the PTO to Off (Fig. 13).
2. Move the throttle lever midway between Slow and Fast (Fig. 13).
3. Let the engine idle for 60 seconds (Fig. 14).
4. Turn the ignition key to Off (Fig. 14).
5. Disconnect the wire from the spark plug(s) to prevent the possibility of someone accidentally starting the machine before it is transported or stored.
6. Close the fuel shutoff valve before transporting or storing the machine.

Important Make sure that the fuel shutoff valve is closed before transporting or storing the machine to prevent fuel leakage. Set the parking brake before transporting the machine. Make sure to remove the key, for the fuel pump may run and cause the battery to lose its charge.



Caution



Children or bystanders may be injured if they move or attempt to operate the machine while it is unattended.

Always remove the ignition key and set the parking brake when leaving the machine unattended, even for a few minutes.

Operating the Power Takeoff (PTO)

The power takeoff (PTO) switch engages and disengages power to the electric clutch.

Engaging the PTO

1. While seated, release the pressure on the traction control levers and shift the machine into neutral.
2. Shift the throttle to Fast.
3. Pull out the power takeoff (PTO) switch to engage the PTO (Fig. 15).

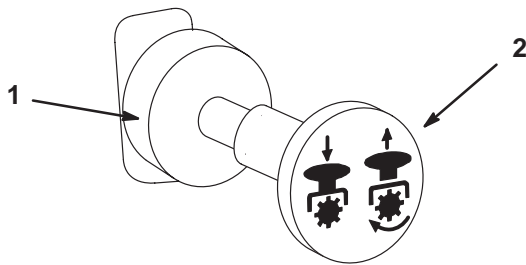

m-4201

Figure 15

1. PTO—Off

2. PTO—On

Disengaging the PTO

To disengage, push the PTO switch to Off (Fig. 15).

The Safety Interlock System



Caution



If safety interlock switches are disconnected or damaged, the machine could operate unexpectedly, causing personal injury.

- Do not tamper with the interlock switches.
- Check the operation of the interlock switches daily and replace any damaged switches before operating the machine.

Understanding the Safety Interlock System

The safety interlock system is designed to prevent the engine from starting unless:

- You are sitting on the seat.
- The parking brake is engaged.
- The power takeoff (PTO) is disengaged.
- The motion control levers are in the neutral lock position.

The safety interlock system is also designed to stop the engine when you move the traction controls with the parking brake is engaged or when you rise from the seat while the PTO is engaged.

Testing the Safety Interlock System

Test the safety interlock system before you use the machine each time. If the safety system does not operate as described below, have an Authorized Service Dealer repair it immediately.

1. While sitting on the seat, engage the parking brake, engage the PTO, and try to start the engine; the engine should not crank.
2. While sitting on the seat, engage the parking brake, disengage the PTO, and move either of the motion control levers (forward or reverse). Then try starting the engine; the engine should not crank. Repeat for the other motion control lever.
3. While sitting on the seat, engage the parking brake, disengage the PTO, lock the motion control levers in neutral, and start the engine. While the engine is running, release the parking brake, engage the PTO, and rise slightly from the seat; the engine should stop.
4. While sitting on the seat, engage the parking brake, disengage the PTO, lock the motion control levers in neutral, and start the engine. While the engine is running, center the motion controls and move (forward or reverse); the engine should stop.

5. While sitting on the seat, disengage the parking brake, disengage the PTO, and move the motion control levers to the neutral lock position. Try starting the engine; the engine should not crank.

Driving Forward or Backward

The throttle control regulates the engine speed as measured in RPM (revolutions per minute). Always operate the throttle control in the Fast position for best performance.

! **Caution** !

The machine can spin very rapidly. The operator may lose control of the machine and cause personal injury or damage to the machine.

- Use caution when turning the machine.
- Slow the machine down before making sharp turns.

Driving Forward

1. Release the parking brake; refer to Releasing the Parking Brake on page 18.
2. Move the levers to the center, unlocked position.
3. To go forward, slowly push the motion control levers forward (Fig. 16).

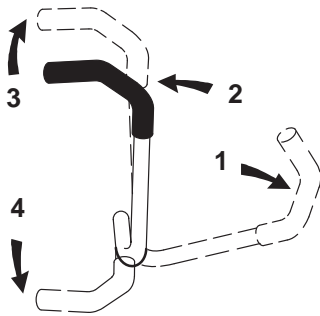

Figure 16

- | | |
|---|--|
| <ol style="list-style-type: none"> 1. Motion control lever—neutral lock position | <ol style="list-style-type: none"> 2. Center unlock position 3. Forward 4. Backward |
|---|--|

Note: The engine will stop if you move the traction control levers while the parking brake is engaged.

Driving Backward

1. Move the levers to the center, unlocked position.
2. To go backward, slowly pull the motion control levers rearward (Fig. 16).

Driving Tips

- To go straight, apply equal pressure to both motion control levers (Fig. 16).
- To turn, release the pressure on the motion control lever toward the direction you want to turn (Fig. 16).

Note: The farther you move the traction control levers in either direction, the faster the machine will move in that direction.

- To stop, push the motion control levers to neutral.

Stopping the Machine

1. Move the traction control levers to neutral and separate them to lock them.
2. Disengage the power takeoff (PTO).
3. Turn the ignition key to Off to stop the engine.
4. Set the parking brake when you leave the machine; refer to Setting the Parking Brake on page 17.
5. Remove the key from the ignition switch.

! **Caution** !

Children or bystanders may be injured if they move or attempt to operate the machine while it is unattended.

Always remove the ignition key and set the parking brake when leaving the machine unattended, even for a few minutes.

PROTOTYPE

Adjusting the Height-of-Cut

The height-of-cut adjusts from 1-1/2 to 4-1/2 inches (38 to 114 mm) in 1/4 inch (6 mm) increments by relocating the clevis pin in different hole locations.

1. Raise the height-of-cut lever to the transport position (also the 4-1/2 inch [114 mm] cutting height position) (Fig. 17).

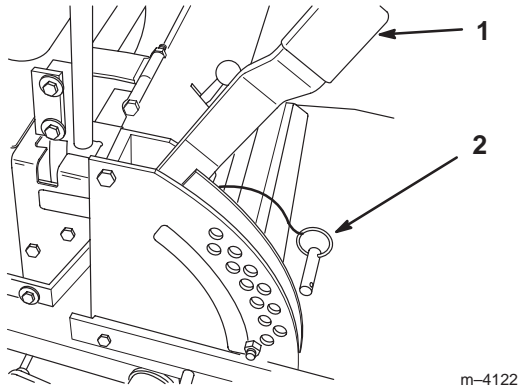

Figure 17

1. Height-of-cut lever
2. Clevis pin

2. Remove the clevis pin from the height-of-cut bracket (Fig. 17).
3. Select the hole in the height-of-cut bracket corresponding to the height-of-cut desired, and insert the clevis pin (Fig. 17).
4. Lower the height-of-cut lever onto the clevis pin (Fig. 17).

Adjusting the Anti-scalp Rollers

Whenever you change the height-of-cut, adjust the height of the anti-scalp rollers.

Adjusting the Outer Roller

1. Disengage the PTO, move the motion control levers to the neutral locked position, and set the parking brake.
2. Stop the engine, remove the key, and wait for all moving parts to stop before leaving the operating position.

3. After adjusting the height-of-cut, remove the flange nut, bushing, spacer, and bolt (Fig. 18).

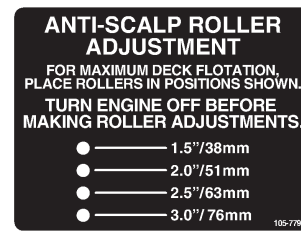

Figure 18

1. Outer roller
2. Spacer
3. Bushing
4. Bolt
5. Nut

4. Select a hole so that the outer roller is positioned to the nearest corresponding height-of-cut desired (Fig. 18).
5. Install the outer roller, bushing, spacer, bolt, and nut (Fig. 18).
6. Torque the bolt to 40 to 45 ft-lb (54 to 61 N·m).

Adjusting the Center Rollers

1. Disengage the PTO, move the motion control levers to the neutral locked position, and set the parking brake.
2. Stop the engine, remove the key, and wait for all moving parts to stop before leaving the operating position.

PROTOTYPE

3. After adjusting the height-of-cut, remove the flange nut, bushing, and bolt (Fig. 19).

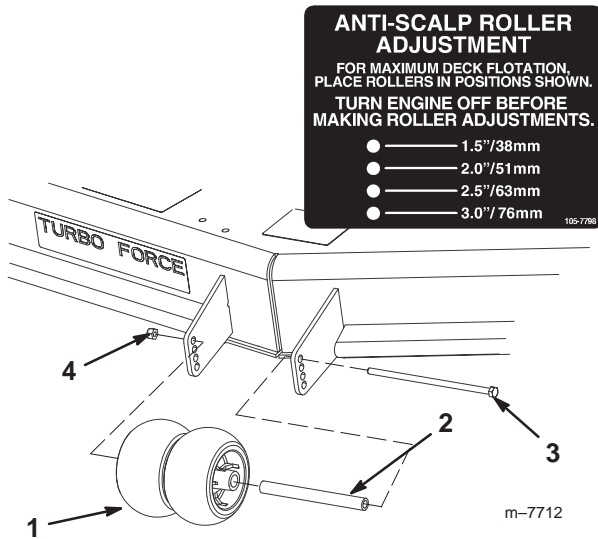

Figure 19

- | | |
|-------------------|---------|
| 1. Center rollers | 3. Bolt |
| 2. Bushing | 4. Nut |

4. Select a hole so that the center rollers are positioned to the nearest corresponding height-of-cut desired (Fig. 19).

Note: Do not adjust the rollers to support the mower housing.

5. Install the center rollers, bushing, spacer, bolt, and nut (Fig. 19).
6. Torque the bolt to 40 to 45 ft-lb (54 to 61 N·m).

Positioning the Seat

The seat can move forward and backward. Position the seat where you have the best control of the machine and are most comfortable.

1. To adjust, move the lever sideways to unlock the seat (Fig. 20).

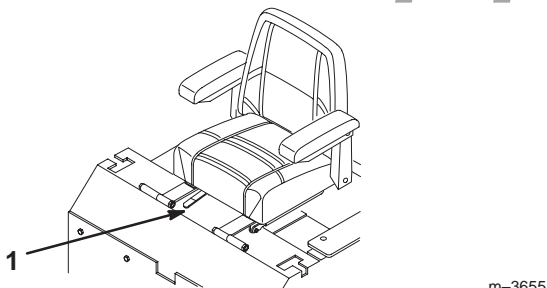

Figure 20

1. Adjustment lever

2. Slide the seat to the desired position and release the lever to lock the seat in position.

Pushing the Machine by Hand

Important Always push the machine by hand. Never tow the machine, because hydraulic damage may occur.

To Push the Machine

1. Disengage the power takeoff (PTO) and turn the ignition key to Off.
2. Rotate the bypass valves counterclockwise 1 turn to push. This allows the hydraulic fluid to bypass the pump, enabling the wheels to turn (Fig. 21).

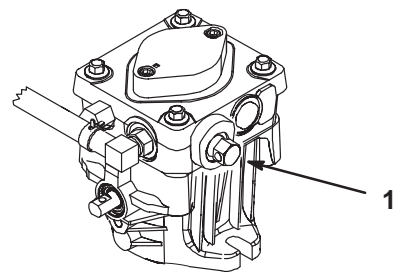

Figure 21

1. Bypass valve

Important Do not rotate the bypass valves more than 1 turn. This prevents the valves from coming out of the body and causing fluid to run out.

Changing to Machine Operation

Turn the bypass valves in to operate (Fig. 21).

Note: Do not overtighten the bypass valves.

Note: The machine will not drive unless the bypass valves are turned in.

PROTOTYPE

Operating with the Side Discharge

The mower has a hinged grass deflector that disperses the clippings to the side and down toward the turf.

⚠Danger⚠

Without the grass deflector, discharge cover, or complete grass catcher assembly mounted in place, you and others are exposed to blade contact and thrown debris. Contact with the rotating mower blade(s) and thrown debris will cause injury or death.

- Never remove the grass deflector from the mower because the grass deflector routes material down toward the turf. If the grass deflector is ever damaged, replace it immediately.
- Never put your hands or feet under the mower.
- Never try to clear the discharge area or the mower blades unless you move the power takeoff (PTO) to *Off* and rotate the ignition key to *Off*. Also remove the key and disconnect the wire from the spark plug(s).
- Ensure that the grass deflector is in the down position.

⚠Warning⚠

Driving on a street or roadway without turn signals, lights, reflective markings, or a slow moving vehicle emblem is dangerous and can lead to accidents that cause personal injury.

Do not drive the machine on a public street or roadway.

Loading the Machines

Use extreme caution when loading machines on trailers or trucks. One full-width ramp that is wide enough to extend beyond the rear tires is recommended instead of individual ramps for each side of the machine (Fig. 22). The lower rear section of the machine frame extends back between the rear wheels and serves as a stop for tipping backward. Having a full-width ramp provides a surface for the frame members to contact if the machine starts to tip backward. If it is not possible to use one full width ramp, use enough individual ramps to simulate a full width continuous ramp.

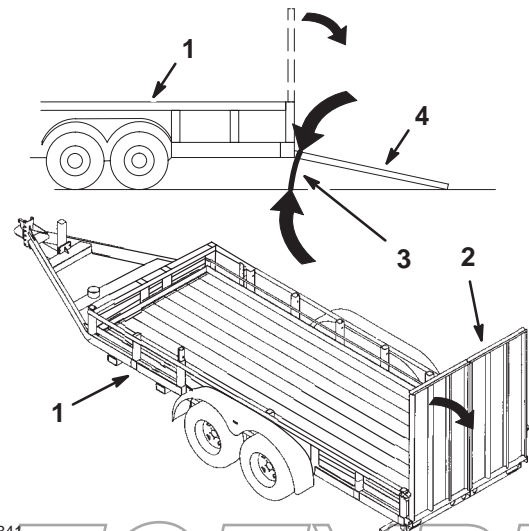

m-6841

Figure 22

Transporting the Machine

Use a heavy-duty trailer or truck to transport the machine. Ensure that the trailer or truck has all necessary lighting and marking as required by law. Please carefully read all the safety instructions. Knowing this information could help you, your family, pets, or bystanders avoid injury.

To transport the machine:

- Lock the brake and block the wheels.
- Securely fasten the machine to the trailer or truck with straps, chains, cable, or ropes.
- Secure a trailer to the towing vehicle with safety chains.



- 1. Trailer
- 2. Full width ramp
- 3. Not greater than 15 degrees
- 4. Full width ramp—side view

The ramp should be long enough so that the angles do not exceed 15 degrees (Fig. 22). A steeper angle may cause mower housing components to get caught as the machine moves from the ramp to the trailer or truck. Steeper angles may also cause the machine to tip backward. If loading on or near a slope, position the trailer or truck so that it is on

the downside of the slope and the ramp extends up the slope. This will minimize the ramp angle. The trailer or truck should be as level as possible.

Important Do not attempt to turn the machine while on the ramp; you may lose control and drive off the side.

Avoid sudden acceleration when driving up a ramp and sudden deceleration when backing down a ramp. Both maneuvers can cause the machine to tip backward.

 **Warning** 

Loading a machine onto a trailer or truck increases the possibility of backward tip over and could cause serious injury or death.

- Use extreme caution when operating a machine on a ramp.
- Use only a single, full-width ramp; *do not* use individual ramps for each side of the machine.
- If you must use individual ramps, use enough ramps to create an unbroken ramp surface wider than the machine.
- *Do not* exceed a 15-degree angle between the ramp and the ground or between the ramp and the trailer or truck.
- Avoid sudden acceleration while driving the machine up a ramp to avoid tipping backward.
- Avoid sudden deceleration while backing machine down a ramp to avoid tipping backward.

Tips for Mowing Grass

Fast Throttle Setting

For best mowing and maximum air circulation, operate the engine at **Fast**. Air is required to thoroughly cut grass clippings, so do not set the height-of-cut so low as to totally surround the mower by uncut grass. Always try to have one side of the mower free from uncut grass, which allows air to be drawn into the mower.

Cutting a Lawn for the First Time

Cut grass slightly longer than normal to ensure that the cutting height of the mower does not scalp any uneven ground. However, the cutting height used in the past is generally the best one to use. When cutting grass longer than 6 inches (15 cm) tall, you may want to cut the lawn twice to ensure an acceptable quality of cut.

Cut 1/3 of the Grass Blade

It is best to cut only about 1/3 of the grass blade. Cutting more than that is not recommended unless grass is sparse, or it is late fall when grass grows more slowly.

Mowing Direction

Alternate the mowing direction to keep the grass standing straight. This also helps disperse clippings, which enhances decomposition and fertilization.

Mow at Correct Intervals

Normally, mow every 4 days. But remember, grass grows at different rates at different times. So to maintain the same cutting height, which is a good practice, mow more often in early spring. As the grass growth rate slows in mid summer, mow less frequently. If you cannot mow for an extended period, first mow at a high cutting height; then mow again 2 days later at a lower height setting.

Cutting Speed

To improve the quality of cut, use a slower ground speed.

Avoid Cutting Too Low

If the cutting width of the mower is wider than the mower you previously used, raise the cutting height to ensure that uneven turf is not cut too short.

Long Grass

If you allow the grass to grow slightly longer than normal, or if it contains a high degree of moisture, raise the cutting height higher than usual and cut the grass at this setting. Then cut the grass again using the lower, normal setting.

When Stopping

If you must stop the machine's forward motion while mowing, a clump of grass clippings may drop onto your lawn. To avoid this, move onto a previously cut area with the blades engaged.

Keep the Underside of the Mower Clean

Clean clippings and dirt from the underside of the mower after each use. If grass and dirt build up inside the mower, the cutting quality will eventually become unsatisfactory.

Blade Maintenance

Maintain a sharp blade throughout the cutting season, because a sharp blade cuts cleanly without tearing or shredding the grass blades. Tearing and shredding turns grass brown at the edges, which slows its growth and increases the chance of disease. Check the cutter blades daily for sharpness, and for any wear or damage. File down any nicks and sharpen the blades as necessary. If a blade is damaged or worn, replace it immediately with a genuine Toro replacement blade.

Maintenance

Note: Determine the left and right sides of the machine from the normal operating position.

Recommended Maintenance Schedule

Maintenance Service Interval	Maintenance Procedure
After First 8 Hours	<ul style="list-style-type: none"> • Check the hydraulic fluid level. • Change the engine oil. • Change the hydraulic filter.
Each Use	<ul style="list-style-type: none"> • Check the engine oil level. • Check the safety system. • Clean the engine air intake¹. • Clean the mower housing.
Every 5 Hours	<ul style="list-style-type: none"> • Check the cutting blades.
Every 25 Hours	<ul style="list-style-type: none"> • Service the foam air cleaner¹. • Check the battery electrolyte.
Every 50 Hours	<ul style="list-style-type: none"> • Check the hydraulic fluid level. • Grease the brake lever. • Oil the linkage bushings¹. • Grease the mower support and push arms. • Grease the blade spindle bearings. • Grease both idler pulley pivots. • Grease the front wheels. • Check the tire pressure. • Check the belts for wear and cracks.
Every 100 Hours	<ul style="list-style-type: none"> • Change the engine oil¹. • Service the paper air cleaner¹. • Check the spark plug(s). • Check the hydraulic lines.
Every 200 Hours	<ul style="list-style-type: none"> • Change the hydraulic filter. • Change the oil filter¹. • Replace the paper air cleaner¹. • Replace the fuel filter. • Grease the brake lever pivot.
Every 300 Hours	<ul style="list-style-type: none"> • Clean the cooling system¹.
Every 500 Hours or at Storage	<ul style="list-style-type: none"> • Adjust and grease the caster pivot. • Adjust the wheel hub slotted nut.
Before Storage	<ul style="list-style-type: none"> • Perform all the maintenance procedures listed above before storage. • Drain the gasoline. • Charge the battery and disconnect the cables. • Paint any chipped surfaces.

¹More often in dusty, dirty conditions

Important Refer to your engine operator's manual for additional maintenance procedures.



Caution



If you leave the key in the ignition switch, someone could accidentally start the engine and seriously injure you or other bystanders.

Remove the key from the ignition and disconnect the wire from the spark plug(s) before you do any maintenance. Set the wire aside so that it does not accidentally contact the spark plug.

Servicing the Cutting Blades

Maintain sharp blades throughout the cutting season, because sharp blades cut cleanly without tearing or shredding the grass blades. Tearing and shredding turns the grass brown at the edges, which slows growth and increases the chance of disease.

Check the cutter blades daily for sharpness, and for any wear or damage. File down any nicks and sharpen the blades as necessary. If a blade is damaged or worn, replace it immediately with a genuine Toro replacement blade. For convenient sharpening and replacement, keep extra blades on hand.



Danger



A worn or damaged blade can break, and a piece of the blade could be thrown into the operator's or bystander's area, resulting in serious personal injury or death.

- Inspect the blade periodically for wear or damage.
- Replace a worn or damaged blade.

Before Inspecting or Servicing the Blades

1. Park the machine on a level surface, disengage the blade control (PTO), and set the parking brake.
2. Turn the ignition key to Off and remove the key.
3. Disconnect the spark plug wire(s) from the spark plug(s).

Inspecting the Blades

1. Inspect the cutting edges (Fig. 23).

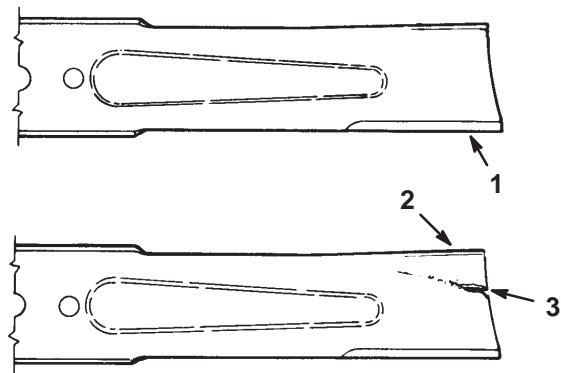

m-151

Figure 23

1. Cutting edge
2. Curved area
3. Wear/slot forming

Note: If the edges are not sharp or have nicks, remove and sharpen the blades; refer to Sharpening the Blades on page 28.

2. Inspect the blades, especially the curved area (Fig. 23).

Note: If you notice any damage, wear, or a slot forming in this area (item 3 in Fig. 23), immediately install a new blade.

Checking for Bent Blades

1. Rotate the blades until the ends face forward and backward (Fig. 24). Measure from a level surface to the cutting edge of the blades (Fig. 25). Note this dimension.

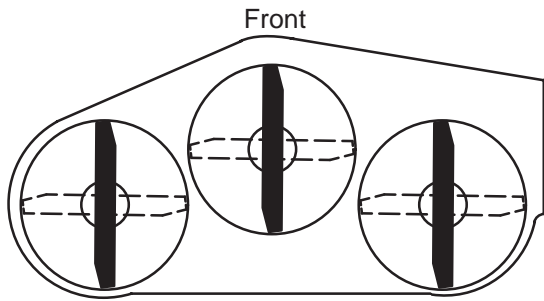

m-1078

Figure 24

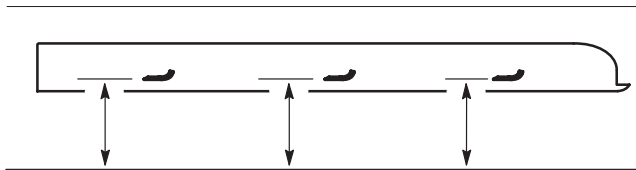

MEASURE FROM
CUTTING EDGE TO A
LEVEL SURFACE

m-2539

Figure 25

2. Rotate the opposite ends of the blades forward.
3. Measure from a level surface to the cutting edge of the blades at the same position as in step 1 above.

Note: The difference between the dimensions obtained in steps 1 and 3 must not exceed 1/8 inch (3 mm). If this dimension exceeds 1/8 inch (3 mm), the blade is bent and must be replaced; refer to Removing the Blades and Installing the Blades on page 28.



Warning



A blade that is bent or damaged could break apart and could seriously injure or kill you or bystanders.

- Always replace a bent or damaged blade with a new blade.
- Never file or create sharp notches in the edges or surfaces of a blade.

Removing the Blades

Replace any blade if it hits a solid object, is out of balance, or is bent. To ensure optimum performance and continued safety conformance of the machine, use genuine Toro replacement blades. Using replacement blades made by other manufacturers may cause the machine to be out of conformance with safety standards.

Hold the blade end using a rag or thickly padded glove. Remove the blade bolt, spring disk, and blade from the spindle shaft (Fig. 26).



Warning



Contact with a sharp blade can cause serious injury.

Wear gloves or wrap the sharp edges of the blade with a rag.

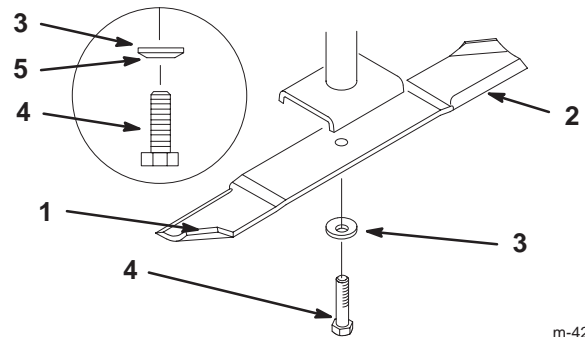

m-4226

Figure 26

1. Sail area of blade
2. Blade
3. Spring disk
4. Blade bolt
5. Cone toward bolt head

Sharpening the Blades



Warning



When you sharpen the blade, pieces of the blade could be thrown and cause serious injury.

Wear proper eye protection when you sharpen the blade.

1. Use a file to sharpen the cutting edge at both ends of the blade at the original angle (Fig. 27).



Figure 27

1. Sharpen at original angle

Note: The blade retains its balance if the same amount of material is removed from both cutting edges.

2. Check the balance of the blade by putting it on a blade balancer (Fig. 28). If the blade stays in a horizontal position, the blade is balanced and can be used. If the blade is not balanced, file some metal off the end of the sail area only (Fig. 26). Repeat this procedure until the blade is balanced.

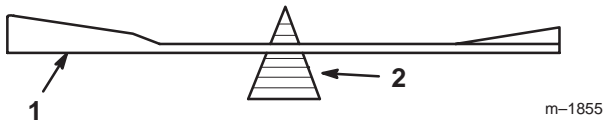

Figure 28

1. Blade
2. Balancer

Installing the Blades

1. Install the blade onto the spindle shaft (Fig. 26).

Important The curved part of the blade must be pointing upward toward the inside of the mower to ensure proper cutting.

2. Install the flat washer, lock washer, and blade bolt (Fig. 26).

Note: Torque the blade bolt to 85–110 ft-lb (115–150 N·m).

Cleaning the Cooling System

Clean the air intake screen from grass and debris before each use.

Check and clean the cooling fins and the engine shrouds every 100 hours or yearly, whichever comes first.

1. Disengage the PTO and set the parking brake.
2. Stop the engine, remove the key, and wait for all moving parts to stop before leaving the operating position.
3. Remove the air intake screen, recoil starter, and fan housing (Fig. 29).

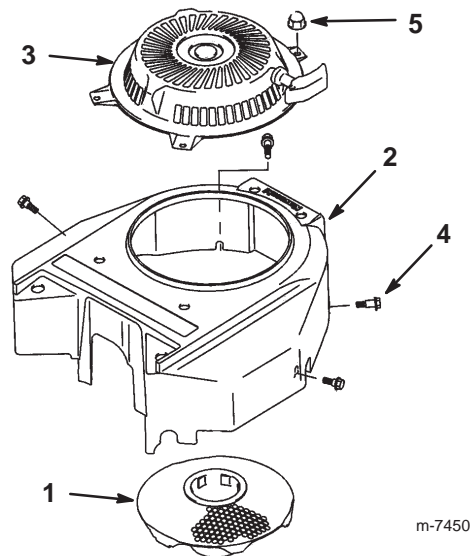

Figure 29

1. Air intake screen
 2. Fan housing
 3. Recoil starter
 4. Bolt
 5. Nut
4. Clean the debris and grass from the engine parts.
 5. Install the air intake screen, recoil starter, and fan housing.

Servicing the Air Cleaner

Primary Filter: Check and/or replace it after every 200 operating hours or more often in dusty conditions.

Safety Filter: Replace it after every 600 operating hours.

Note: Check the filters more frequently if the operating conditions are extremely dusty or sandy.

Removing the Filters

1. Disengage the PTO, move the motion control levers to the neutral locked position, and set the parking brake.
2. Stop the engine, remove the key, and wait for all moving parts to stop before leaving the operating position.
3. Release the latches on the air cleaner and pull the air cleaner cover off the air cleaner body (Fig. 30).

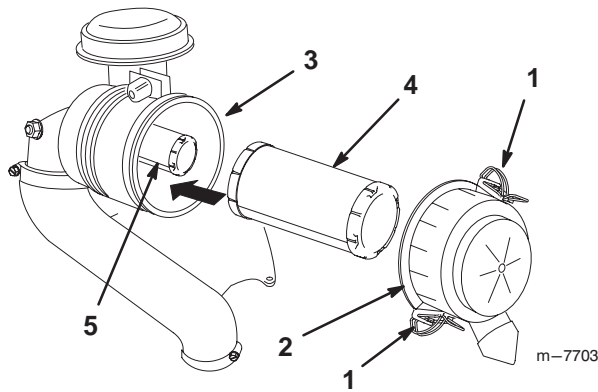

Figure 30

- | | |
|----------------------|-------------------|
| 1. Latch | 4. Primary filter |
| 2. Air cleaner cover | 5. Safety filter |
| 3. Air filter body | |

4. Clean the inside of the air cleaner cover with compressed air.
5. Gently slide the primary filter out of the air cleaner body (Fig. 30).

Note: Avoid knocking the filter into the side of the body.

6. Remove the safety filter **only if you intend to replace it**.

Important Never attempt to clean the safety filter. If the safety filter is dirty, then the primary filter is damaged. Replace both filters.

7. Inspect the primary filter for damage by looking into the filter while shining a bright light on the outside of the filter. Holes in the filter will appear as bright spots. If the filter is damaged, discard it.

Servicing the Primary Filter

- Check and/or replace the primary filter after 200 operating hours.
- If the primary filter is dirty, bent, or damaged, replace it.
- Do not clean the primary filter.

Servicing the Safety Filter

Replace the safety filter after 600 operating hours.

Important Never attempt to clean the safety filter. If the safety filter is dirty, then the primary filter is damaged. Replace both filters.

Installing the Filters

Important To prevent engine damage, always operate the engine with both air filters and cover installed.

1. If installing new filters, check each filter for shipping damage. Do not use a damaged filter.
2. If the safety filter is being replaced, carefully slide it into the filter body (Fig. 30).
3. Carefully slide the primary filter over the safety filter (Fig. 30).

Note: Ensure that the primary filter is fully seated by pushing on its outer rim while installing it.

Important Do not press on the soft inside area of the filter.

4. Install the air cleaner cover with the side indicated as **UP** facing upward and secure the latches (Fig. 30).

PROTOTYPE

Servicing the Engine Oil

Service Interval/Specification

Change the engine oil:

- After the first 8 operating hours
- After every 100 operating hours

Note: Change the oil more frequently when the operating conditions are extremely dusty or sandy.

Oil Type: Detergent oil (API service SF, SG, SH, or SJ)

Crankcase Capacity: 58 ounces (1.7 liter) with the filter removed; 51 ounces (1.5 liter) without the filter removed

Viscosity: Refer to the table below

USE THESE SAE VISCOSITY OILS

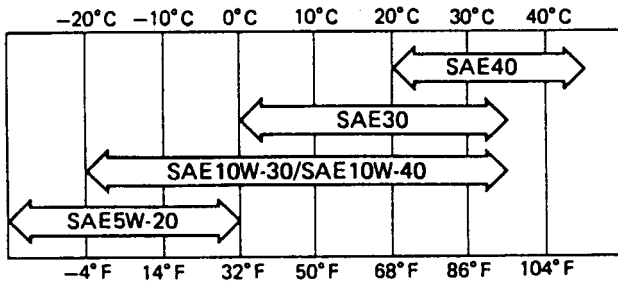

Checking the Engine Oil Level

1. Park the machine on a level surface.
2. Disengage the PTO and set the parking brake.
3. Stop the engine, remove the key, and wait for all moving parts to stop before leaving the operating position.
4. Clean around the oil dipstick (Fig. 31) so that dirt cannot fall into the filler hole and damage the engine.

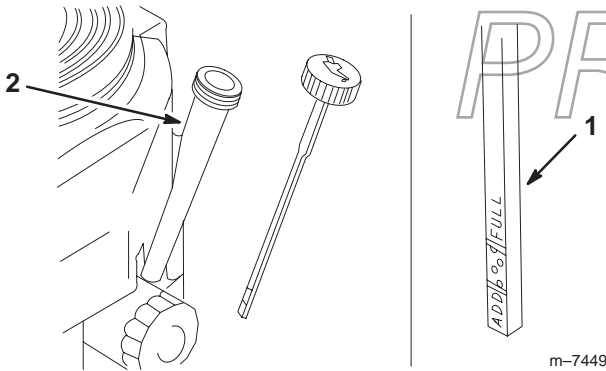

Figure 31

1. Oil dipstick
2. Filler tube

5. Unscrew the oil dipstick and wipe the end clean (Fig. 31).
6. Slide the oil dipstick fully into the filler tube, **but do not thread it onto the tube** (Fig. 31).
7. Pull the dipstick out and look at the end. If the oil level is low, slowly pour only enough oil into the filler tube to raise the level to the Full mark.

Important Do not overfill the crankcase with oil and run the engine; engine damage can result.

Changing the Oil

1. Start the engine and let it run 5 minutes. This warms the oil so that it drains better.
2. Park the machine so that the drain side is slightly lower than the opposite side to ensure that the oil drains completely.
3. Disengage the PTO and set the parking brake.
4. Stop the engine, remove the key, and wait for all moving parts to stop before leaving the operating position.
5. Slide the drain hose over the oil drain valve.
6. Place a pan below the drain hose.
7. Rotate oil drain valve to allow oil to drain (Fig. 32).

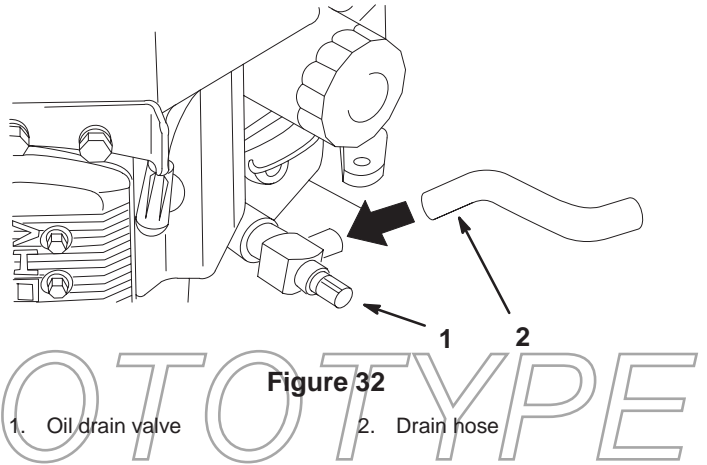

Figure 32

1. Oil drain valve
2. Drain hose
8. When oil has drained completely, close the drain valve.
9. Remove the drain hose (Fig. 32).

Note: Dispose of the used oil at a recycling center.

10. Slowly pour approximately 80% of the specified oil (refer to Service Interval/Specification on page 30) into the filler cap (Fig. 31).
11. Check the oil level; refer to Checking the Engine Oil Level on page 30.
12. Slowly add the additional oil to bring it to the Full mark.

Changing the Oil Filter

Replace the oil filter every 200 operating hours or every other oil change.

Note: Change the oil filter more frequently when the operating conditions are extremely dusty or sandy.

1. Drain the oil from the engine; refer to Changing the Oil on page 30.
2. Remove the old oil filter (Fig. 33).

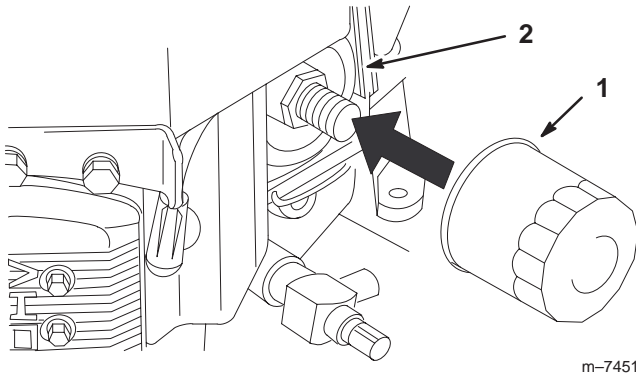

Figure 33

1. Oil filter
2. Adapter
3. Apply a thin coat of new oil to the rubber gasket on the replacement filter (Fig. 33).
4. Install the replacement oil filter to the filter adapter, turn the oil filter clockwise until the rubber gasket contacts the filter adapter, then tighten the filter an additional 3/4 turn (Fig. 33).
5. Fill the crankcase with the proper type of new oil; refer to Servicing the Engine Oil on page 30.
6. Run the engine for about 3 minutes, stop the engine, and check for oil leaks around the oil filter.
7. Check the engine oil level and add oil if needed.

Servicing the Spark Plug(s)

Service Interval/Specification

Check the spark plug(s) after every 100 operating hours. Ensure that the air gap between the center and side electrodes is correct before installing the spark plug(s). Use a spark plug wrench for removing and installing the spark plug(s) and a gapping tool/feeler gauge to check and adjust the air gap. Install a new spark plug if necessary.

Type: Champion® RCJ-8Y or equivalent
Air Gap: 0.030 inch (0.75 mm)

Removing the Spark Plug(s)

1. Disengage the PTO and set the parking brake.
2. Stop the engine, remove the key, and wait for all moving parts to stop before leaving the operating position.
3. Disconnect the wire(s) from the spark plug(s) (Fig. 34).

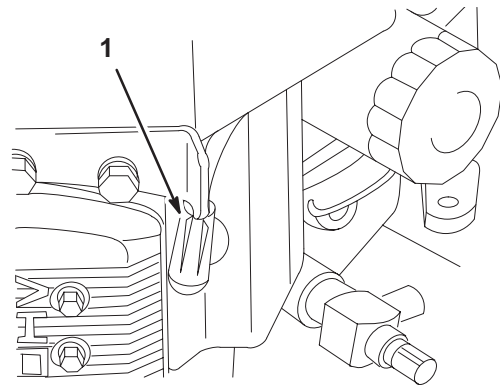

Figure 34

1. Spark-plug wire/spark plug
4. Clean around the spark plug(s) to prevent dirt from falling into the engine and potentially causing damage.
5. Remove the spark plug(s) and the metal washer(s).

Checking the Spark Plug(s)

1. Look at the center of the spark plug(s) (Fig. 35). If you see light brown or gray on the insulator, the engine is operating properly. A black coating on the insulator usually means that the air cleaner is dirty.

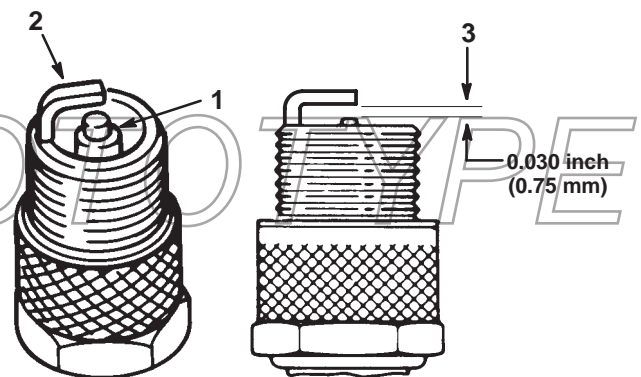

Figure 35

1. Center electrode insulator
2. Side electrode
3. Air gap (not to scale)

Important Always replace the spark plug(s) when it has a black coating, worn electrodes, an oily film, or cracks.

2. Check the gap between the center and side electrodes (Fig. 35).
Note: Bend the side electrode (Fig. 35) if the gap is not correct.

Installing the Spark Plug(s)

1. Install the spark plug(s) and the metal washer(s).
Note: Ensure that the air gap is set correctly.
2. Tighten the spark plug(s) to 16 ft-lb (22 N•m).
3. Connect the wire(s) to the spark plug(s) (Fig. 34).

Replacing the Fuel Filter

Replace the fuel filter after every 200 operating hours or yearly, whichever occurs first.

Never install a dirty filter if it is removed from the fuel line.

1. Disengage the PTO, move the motion control levers to the neutral locked position, and set the parking brake.
2. Stop the engine, remove the key, and wait for all moving parts to stop before leaving the operating position.
3. Allow the machine to cool down.
4. Stop the engine, remove the key, and wait for all moving parts to stop before leaving the operating position.
5. Close the fuel shutoff valve (Fig. 36).

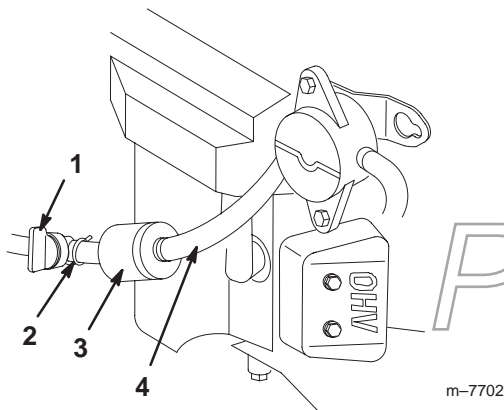

Figure 36

- | | |
|-----------------------|----------------|
| 1. Fuel shutoff valve | 3. Fuel line |
| 2. Hose clamp | 4. Fuel filter |

6. Squeeze the ends of the hose clamps together and slide them away from the filter (Fig. 36).

7. Remove the filter from the fuel lines.
8. Install a new filter and move the hose clamps close to the filter (Fig. 36).
9. Open the fuel shutoff valve.

Draining the Fuel Tank

⚠
Danger
⚠

In certain conditions, gasoline is extremely flammable and highly explosive. A fire or explosion from gasoline can burn you and others and can damage property.

- **Drain gasoline from the fuel tank when the engine is cold. Do this outdoors in an open area. Wipe up any gasoline that spills.**
- **Never smoke when draining gasoline, and stay away from an open flame or where a spark may ignite the gasoline fumes.**

1. Park the machine on a level surface to ensure that the fuel tanks drain completely.
2. Disengage the power takeoff (PTO), set the parking brake, stop the engine, and remove the key.
3. Close the fuel shutoff valve (Fig. 36).
4. Loosen the hose clamp at the fuel filter and slide it up the fuel line away from the fuel filter (Fig. 36).
5. Disconnect the fuel line from the fuel filter (Fig. 36).
6. Open the fuel shutoff valve.
Note: Allow gasoline to drain into a fuel container can or drain pan (Fig. 36).

Note: Now is the best time to install a new fuel filter because the fuel tank is empty.

7. Install the fuel line onto the fuel filter. Slide the hose clamp close to the fuel filter to secure the fuel line (Fig. 36).

Greasing and Lubrication

Lubricate the machine at the intervals shown on the **Check Service Reference Aid** decal (Fig. 37). Lubricate more frequently when operating conditions are extremely dusty or sandy.

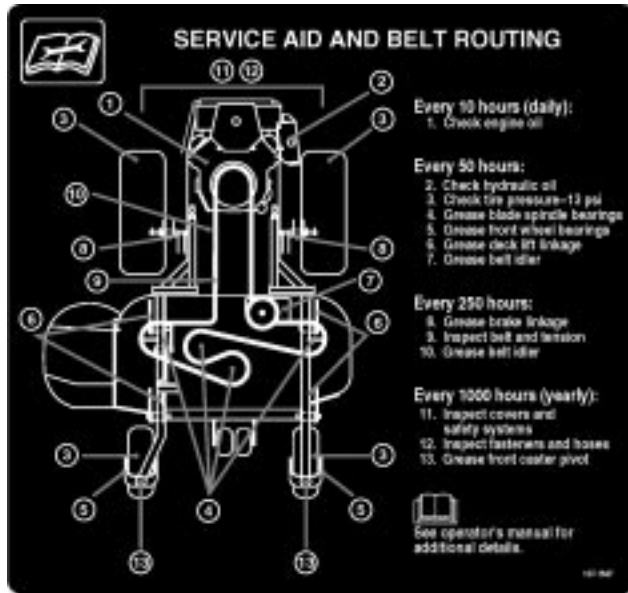

Figure 37

Lubricate with No. 2 general-purpose lithium-base or molybdenum-base grease.

How to Grease

1. Disengage the PTO, move the motion control levers to the neutral locked position, and set the parking brake.
2. Stop the engine, remove the key, and wait for all moving parts to stop before leaving the operating position.
3. Clean the grease fittings with a rag. Make sure to scrape any paint off the front of the fitting(s).
4. Connect a grease gun to the fitting and pump grease into the fittings until the grease begins to ooze out from the bearings.
5. Wipe up any excess grease.

Where to Add Grease

Lubricate the grease fittings as shown on the **Check Service Reference Aid** decal (Fig. 37).

Greasing the Front Caster Pivots

Lubricate the front caster pivots once a year.

1. Remove the dust cap and adjust the caster pivots.

Note: Keep dust cap off until greasing is done. Refer to Adjusting the Caster Pivot Bearing on page 38.
2. Remove the hex plug and thread a grease zerk into the hole.
3. Pump grease into the zerk until it oozes out around the top bearing.
4. Remove the grease zerk in the hole and install the hex plug and cap.

Greasing the Bearings

Lubricate the cutting machine regularly; refer to the Recommended Maintenance Schedule on page 25. Grease with No. 2 general-purpose lithium-base or molybdenum-base grease.

1. Disengage the PTO, move the motion control levers to the neutral locked position, and set the parking brake.
2. Stop the engine, remove the key, and wait for all moving parts to stop before leaving the operating position.
3. Grease the fittings on the 3 spindle bearings (Fig. 38).

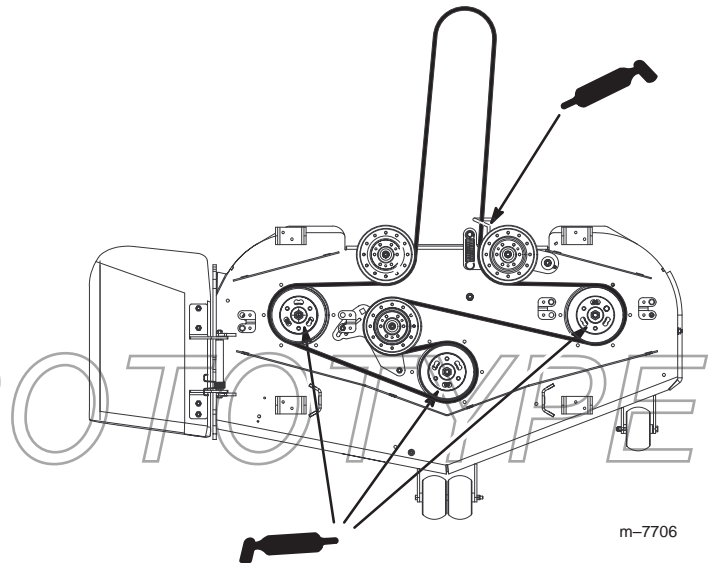

Figure 38

4. Grease the idler pulley pivot (Fig. 38).
5. Grease the fittings on the push arms (Fig. 38).

Where to Add Light Oil or Spray Lubrication

Lubricate the machine in the following areas with spray type lubricant or light oil. Lubricate every 160 hours.

- Seat switch actuator
- Brake handle pivot
- Brake rod bushings
- Motion control bronze bushings

Checking the Tire Pressure

Maintain the air pressure in the front and rear tires as specified. Uneven tire pressure can cause an uneven cut. Check the pressure at the valve stem after every 50 operating hours or monthly, whichever occurs first (Fig. 39). Check the tires when they are cold to get the most accurate pressure reading.

Pressure: 13 psi (90 kPa) drive wheels and caster wheels

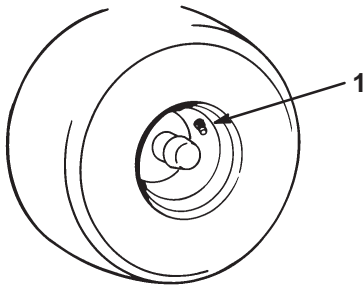

Figure 39

m-1872

1. Valve stem

Servicing the Hydraulic System

Checking the Hydraulic Fluid

Check the hydraulic fluid level:

- Before the engine is first started
- After the first 8 operating hours
- After every 50 operating hours

Fluid Type: Mobil 1 15W-50 synthetic motor oil or equivalent synthetic oil.

Important Use the specified oil or equivalent. Other fluids could cause system damage.

Hydraulic System Oil Capacity: 67 oz. (2.0 l)

Note: There are 2 ways of checking the hydraulic oil. One is for warm oil and the other for cold oil. The baffle inside the tank has 2 levels depending on whether the oil is warm or cold.

1. Move the machine onto a level surface and set the parking brake.
2. Clean area around filler neck of hydraulic tank (Fig. 40).

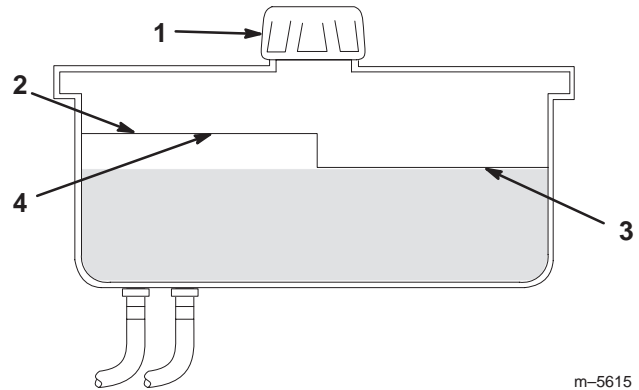

m-5615

Figure 40

1. Cap
2. Baffle
3. Cold fluid level—full
4. Hot fluid level—full

3. Remove the cap from the filler neck and look inside to check if there is fluid in the reservoir (Fig. 40).
4. If there is no fluid, add fluid to the reservoir until it reaches the Cold level of the baffle.
5. Run the machine at low idle for 15 minutes to allow any air to purge out of the system and warm the fluid. Refer to Starting and Stopping the Engine on page 18.
6. Check the fluid level while the fluid is warm. The fluid should be between the Cold and Hot levels.
7. If required, add fluid to the hydraulic tank.

Note: The fluid level should be to the top of the Hot level of the baffle when the fluid is hot (Fig. 40).

8. Install cap on filler neck.



Warning



Hydraulic fluid escaping under pressure can penetrate skin and cause injury.

- If hydraulic fluid is injected into the skin, it must be surgically removed within a few hours by a doctor familiar with this type of injury; otherwise, gangrene may result.
- Keep your body and hands away from pin hole leaks or nozzles that eject high-pressure hydraulic fluid.
- Use cardboard or paper to find hydraulic leaks.
- Safely relieve all pressure in the hydraulic system before performing any work on the hydraulic system.
- Ensure that all hydraulic fluid hoses and lines are in good condition and all hydraulic connections and fittings are tight before applying pressure to the hydraulic system.

Replacing the Hydraulic Filter

Change the hydraulic filter:

- After the first 8 operating hours
- After every 200 operating hours

Use a summer filter above 32°F (0°C)

Use a winter filter below 32°F (0°C)

1. Disengage the PTO, move the motion control levers to the neutral locked position, and set the parking brake.
2. Stop the engine, remove the key, and wait for all moving parts to stop before leaving the operating position.

Important Do not substitute an automotive oil filter for a hydraulic filter; this can severely damage the hydraulic system.

3. Place a drain pan under the filter, remove the old filter, and wipe the filter adapter gasket surface clean (Fig. 41).

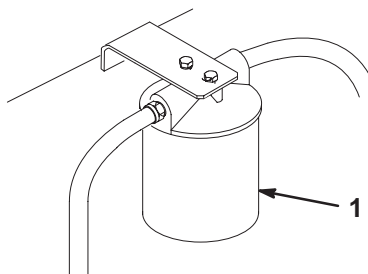
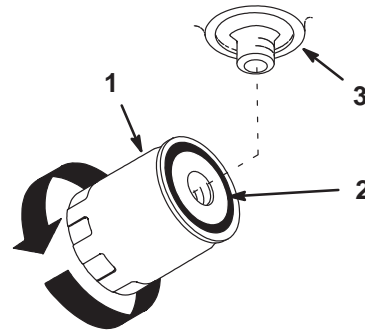

Figure 41

m-4763

1. Hydraulic filter

4. Apply a thin coat hydro fluid to the rubber gasket on the replacement filter (Fig. 42).



m-1256

Figure 42

1. Hydraulic filter
2. Gasket
3. Adapter

5. Install the replacement hydraulic filter onto the filter adapter, but do not tighten.
6. Fill the hydraulic tank with hydraulic fluid until the fluid overflows the filter
7. Turn the oil filter clockwise until the rubber gasket contacts the filter adapter, then tighten the filter an additional 1/2 turn (Fig. 42).
8. Clean up any spilled fluid.
9. Add fluid to the cold level of the baffle in the hydraulic tank.
10. Start the engine and let it run for about 2 minutes to purge air from the system. Stop the engine and check for leaks.
- Note:** If one or both wheels will not drive, refer Bleeding Hydraulic System on page 35.
11. Check the fluid level while the fluid is warm.
- Note:** The fluid should be between cold and hot.
12. If required, add fluid to the hydraulic tank. **Do not overfill.**

Bleeding the Hydraulic System

The traction system is self bleeding; however, it may be necessary to bleed the system if the fluid is changed or after work is performed on the system.

1. Raise the rear of the machine so that the wheels are off the ground and support it with jack stands.
2. Start the engine and run at low idle speed.
3. Engage the lever and traction on one side and spin the wheel by hand.
4. When the wheel begins to spin on its own, keep it engaged until wheel drives smoothly. (minimum 2 minutes)

5. Check hydraulic fluid level and add fluid as required to maintain the proper level.
6. Repeat this procedure on the opposite wheel.

! **Warning** !

Hydraulic fluid escaping under pressure can penetrate skin and cause injury.

- If hydraulic fluid is injected into the skin it must be surgically removed within a few hours by a doctor familiar with this type of injury; otherwise, gangrene may result.
- Keep your body and hands away from pin hole leaks or nozzles that eject high pressure hydraulic fluid.
- Use cardboard or paper to find hydraulic leaks.
- Safely relieve all pressure in the hydraulic system before performing any work on the hydraulic system.
- Ensure that all hydraulic fluid hoses and lines are in good condition and all hydraulic connections and fittings are tight before applying pressure to hydraulic system.

Checking the Hydraulic Lines

After every 100 operating hours, check the hydraulic lines and hoses for leaks, loose fittings, kinked lines, loose mounting supports, wear, weather, and chemical deterioration. Make necessary repairs before operating.

Note: Keep areas around the hydraulic system clean from grass and debris buildup.

Waste Disposal

Engine oil, hydraulic oil, and engine coolant are pollutants to the environment. Dispose of these according to your state and local regulations.

Adjusting the Handle Neutral Position

If the motion control levers do not align or move easily into the console notch, adjust them. Adjust each lever, spring, and rod separately.

Note: The motion control levers must be installed correctly. See Installing the Motion Control Levers in the Setup instructions.

1. Disengage the PTO, move the motion control levers to the neutral locked position, and set the parking brake.
2. Stop the engine, remove the key, and wait for all moving parts to stop before leaving the operating position.

3. Tilt the seat forward.
4. Begin with either the left or right motion control lever.
5. Move lever to the neutral position but **not locked** (Fig. 43).

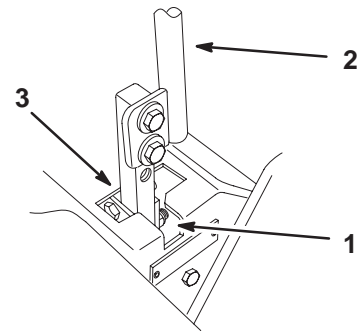

m-6282

Figure 43

1. Neutral locked position
2. Control lever
3. Neutral position

6. Pull the lever back until the clevis pin (on the arm below the pivot shaft) contacts the end of the slot (just beginning to put pressure on the spring) (Fig. 44).

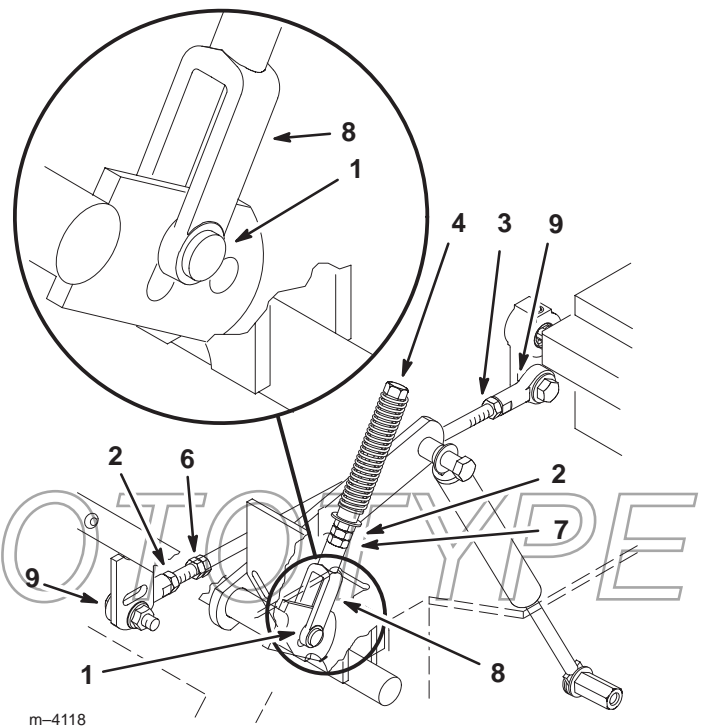

m-4118

Figure 44

1. Clevis pin in slot
2. Nut
3. Nut—Left hand thread
4. Adjustment bolt
5. Pump rod
6. Double nuts
7. Jam nut
8. Yoke
9. Ball joint

7. Check where the control lever is relative to the notch in the console (Fig. 43). It should be centered, allowing the lever to pivot outward to the neutral lock position.
8. If adjustment is needed, loosen the nut and jam nut against the yoke (Fig. 44).
9. Apply slight rearward pressure on the motion control lever, and turn the head of the adjustment bolt in the appropriate direction until the control lever is centered in the neutral lock position (Fig. 43).

Note: Keeping rearward pressure on the lever will keep the pin at the end of the slot and allow the adjustment bolt to move the lever to the appropriate position.

10. Tighten the nut and jam nut (Fig. 44).
11. Repeat on the opposite side of machine.

Setting the Hydraulic Pump Neutral Position

Note: Adjust the handle neutral first. That has to be correct before you can perform the following adjustment.

! **Danger** !

Mechanical or hydraulic jacks may fail to support the machine and cause a serious injury.

- Use jack stands when supporting the machine.
- Do not use hydraulic jacks.

! **Warning** !

The engine must be running so that you can adjust the motion control. Contact with moving parts or hot surfaces may cause personal injury.

Keep your hands, feet, face, clothing and other body parts away from rotating parts, muffler, and other hot surfaces.

You must make this adjustment with the drive wheels turning.

1. Raise the frame and block up the machine so that the drive wheels can rotate freely.
2. Disconnect the electrical connector from the seat safety switch. **Temporarily** install a jumper wire across terminals in the wiring harness connector.
3. Slide the seat forward, disconnect the prop rod and tilt the seat fully forward.

Setting the Left-hand Hydraulic Pump Neutral Position

1. Start the engine, open the throttle halfway and release the parking brake. Refer to Starting and Stopping the Engine on page 18.

Note: The motion control lever must be in neutral while you are making any adjustments.

2. Adjust the pump rod length by rotating the knob in the appropriate direction until the wheel is still or slightly creeping in reverse (Fig. 45).

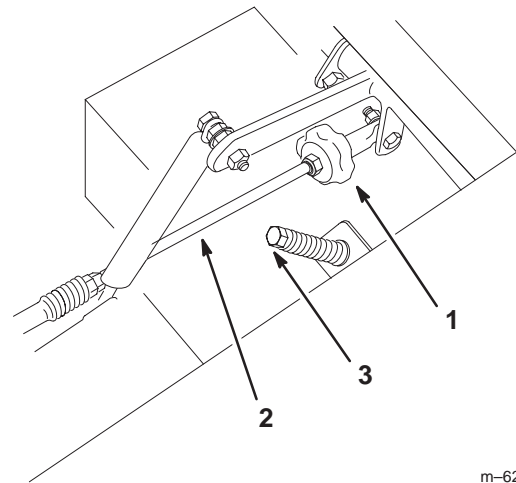

m-6283

Figure 45

- | | |
|------------------|--------------------|
| 1. Tracking knob | 3. Adjustment bolt |
| 2. Pump rod | |

3. Move the motion control lever forward and reverse, then back to neutral. The wheel must stop turning or slightly creep in reverse.
4. Open throttle to fast.

Note: Ensure that the wheel remains stopped or slightly creeps in reverse, and adjust it if necessary.

Setting the Right-hand Hydraulic Pump Neutral Position

1. Loosen the locknuts at the ball joints on the pump control rod (Fig. 44).
2. Start the engine, open the throttle halfway, and release the parking brake. Refer to Starting and Stopping the Engine on page 18.

Note: The motion control lever must be in neutral while you are making any adjustments.

Note: The front nut on the pump rod has left-hand threads.

3. Adjust the pump rod length by rotating the double nuts on the rod in the appropriate direction until the wheel is still or slightly creeps in reverse (Fig. 44).
4. Move the motion control lever forward and reverse, then back to neutral. The wheel must stop turning or slightly creep in reverse.
5. Open the throttle to Fast. Ensure that the wheel remains stopped or slightly creeps in reverse, adjust if necessary.
6. Tighten the nuts at the ball joints (Fig. 44).

! **Warning** !

The electrical system will not perform the proper safety shutoff with the jumper wire installed.

- Remove the jumper wire from the wire harness connector and plug the connector into the seat switch after completing the adjustment.
- Never operate the machine with the jumper wire installed and the seat switch bypassed.

7. After both pump neutrals are set, shut off the machine.
8. Remove the jumper wire from the wire harness connector and plug the connector into the seat switch.
9. Install the prop rod and lower the seat into position.
10. Remove the jack stands.

Adjusting the Tracking

The left-hand pump has a knob for adjusting the tracking.

Important Adjust the handle neutral and the hydraulic pump neutral before adjusting the tracking. Refer to Adjusting the Handle Neutral on page 36 and Adjusting the Hydraulic Pump Neutral on page 37.

1. Push both control levers forward the same distance.
2. Check if the machine pulls to one side. If it does, stop the machine and set the parking brake.
3. Tip the seat up to access the tracking knob.

Note: Determine the left and right sides of the machine from the normal operating position.

4. To make the machine move to the right, turn the knob toward the right side of the machine; refer to Figure 46.

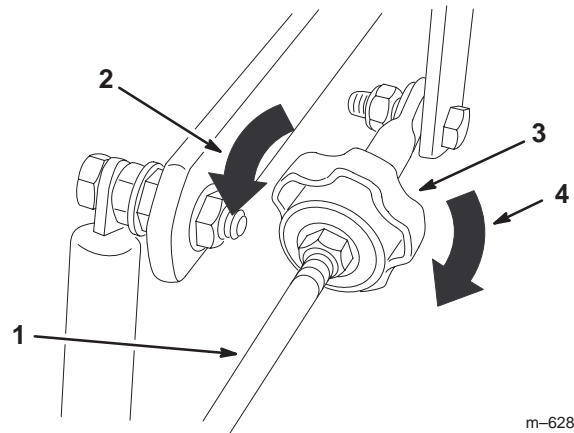

m-6280

Figure 46

1. Pump rod
2. Turn this way to track left
3. Tracking knob
4. Turn this way to track right
5. To make the machine move to the left, turn the knob toward the left side of the machine; refer to Figure 46.
6. Repeat the adjustment until the tracking is correct.

Adjusting the Caster Pivot Bearing

Check after every 500 operating hours or at storage, whichever occurs first.

1. Disengage the PTO, move the motion control levers to the neutral locked position, and set the parking brake.
2. Stop the engine, remove the key, and wait for all moving parts to stop before leaving the operating position.
3. Remove the dust cap from the caster and tighten the locknut (Fig. 47).

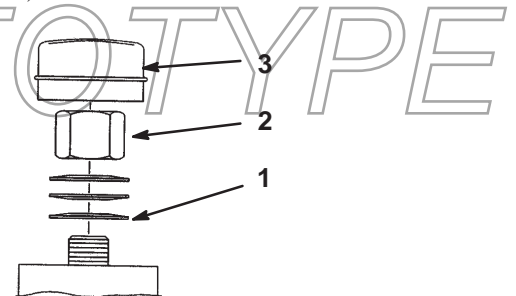

m-4640

Figure 47

1. Spring washers
2. Locknut
3. Dust cap

- Tighten the locknut until the spring washers are flat, then back off 1/4 turn to properly set the pre-load on the bearings (Fig. 47).

Important Ensure that the spring washers are installed correctly as shown in Figure 47.

Checking the Wheel Hub Slotted Nut

Check after every 500 operating hours.

The slotted nut needs to be torqued to 125 ft-lb (170 N·m).

- Disengage the PTO, move the motion control levers to the neutral locked position, and set the parking brake.
- Stop the engine, remove the key, and wait for all moving parts to stop before leaving the operating position.
- Remove the cotter pin.
- Torque the slotted nut to 125 ft-lb (170 N·m) (Fig. 48).

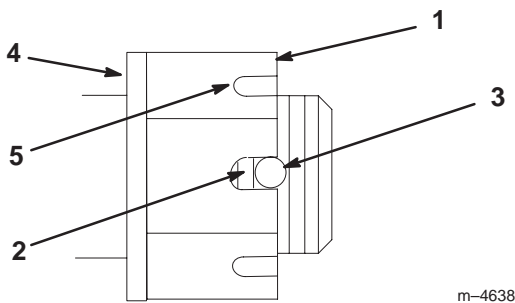

Figure 48

- | | |
|--------------------------------|---------------------------|
| 1. Slotted nut | 3. Hole in threaded shaft |
| 2. Two threads or less showing | 4. Washer (if needed) |
| | 5. Slot |

- Check the distance from the bottom of the slot in the nut to the inside edge of the hole.

Note: No more than 2 threads should be showing (Fig. 48).

- If more than 2 threads are showing, remove the nut and install a washer between the hub and nut (Fig. 48).
- Torque the slotted nut to 125 ft-lb (170 N·m) (Fig. 48).
- Tighten the nut until the next set of slots line up with the hole in the shaft (Fig. 48).
- Install the cotter pin.

Leveling the Mower at Three Positions

Important There are only 3 measuring positions needed to level the mower.

Setting Up the Machine

- Position mower on a flat surface.
- Disengage the PTO, move the motion control levers to the neutral locked position, and set the parking brake.
- Stop the engine, remove the key, and wait for all moving parts to stop before leaving the operating position.
- Check tire pressure of all 4 tires. If needed, adjust them to 13 psi (90 kPa)
- Position the mower to the 3-inch (76 mm) height-of-cut position.
- Inspect the 4 chains; the chains need to have tension.

Note: Adjust the rear chains to the top of the slot, where they are attached to the mower.

- If one rear chain is loose, lower (loosen) the front support arm on the same side. Refer to Adjusting the Front-to-Rear Mower Pitch on page 40.
- If one front chain is loose, raise (tighten) the front support arm for that chain. Refer to Adjusting the Front-to-Rear Mower Pitch on page 40.

Leveling the Mower Side-to-Side

- Position the **right** blade front to rear (Fig. 49).

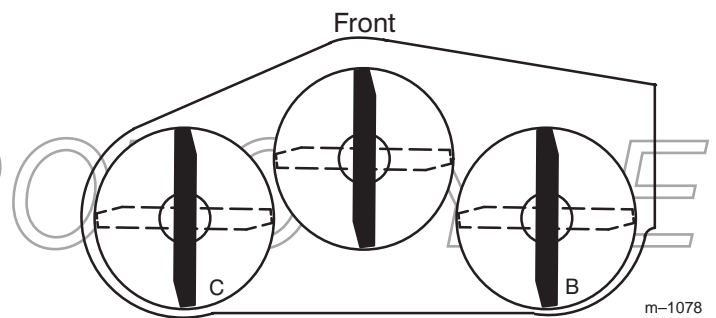

Figure 49

2. Measure the right blade at the **B** location (Fig. 49), from a level surface to the cutting edge of the blade tip (Fig. 50).

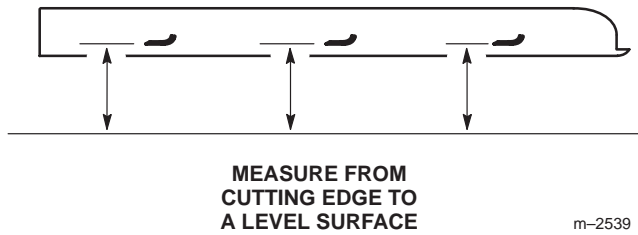

Figure 50

3. Record this measurement; this measurement must be 3-1/8 to 3-1/4 inches (79 to 83 mm).
4. Position the **left** blade front to rear (Fig. 49).
5. Measure the left blade at the **C** location (Fig. 49), from a level surface to the cutting edge of the blade tip (Fig. 50).
6. Record this measurement. This measurement must be 3-1/8 to 3-1/4 inches (79 to 83 mm).
7. If the measurements at positions **B** or **C** are incorrect, loosen the bolt that attaches the rear chain to the rear support arm (Fig. 51).

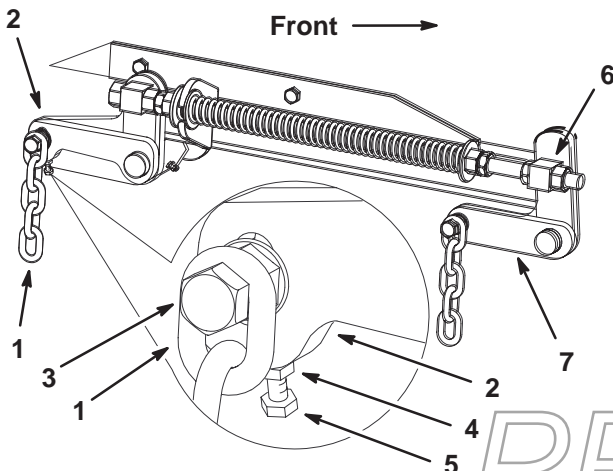

Figure 51

- | | |
|---------------------|----------------------|
| 1. Rear chain | 5. Adjustment bolt |
| 2. Rear support arm | 6. Front swivel |
| 3. Bolt | 7. Front support arm |
| 4. Jam Nut | |

8. Loosen the jam nut under the rear support arm and adjust the adjustment bolt to get a measurement of 3-1/8 to 3-1/4 inches (79 to 83 mm).

Note: It is recommended that both sides of the mower are adjusted the same distance.

9. Tighten the jam nut under the rear support arm and tighten the bolt that secures the chain to the rear support arm.
10. Adjust the opposite side if needed.

Adjusting the Front-to-Rear Mower Pitch

1. Position the **right** blade front to rear (Fig. 52).

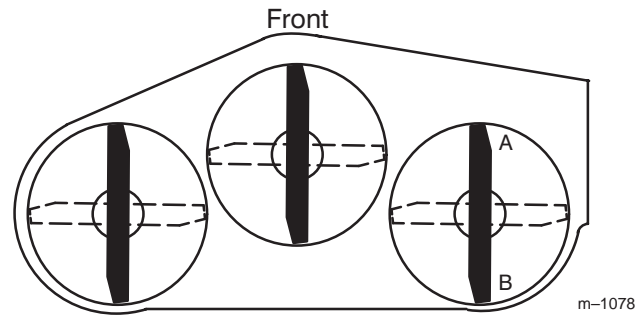

Figure 52

2. Measure the right blade at the **A** location (Fig. 52) from a level surface to the cutting edge of the blade tip (Fig. 53).

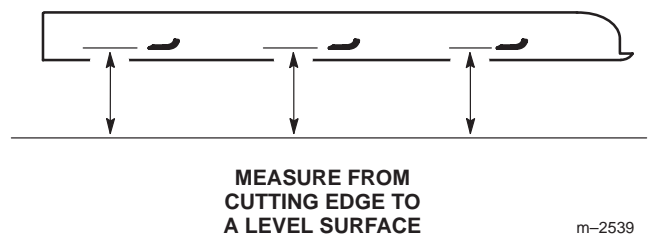

Figure 53

3. Record this measurement.
4. Measure the right blade at the **B** location (Fig. 52) from a level surface to the cutting edge of the blade tip (Fig. 53).
5. Record this measurement.
6. The mower blade should be **1/4 to 3/8 inch (6 to 10 mm) lower at position A than at position B** (Fig. 52). If it is not correct, go to the following steps.

Note: You must adjust both of the front swivels the same amount to maintain equal chain tension.

- Loosen the front swivel jam nuts, at the front of the right and left swivels, approximately 1/2 inch (13 mm) (Fig. 54).

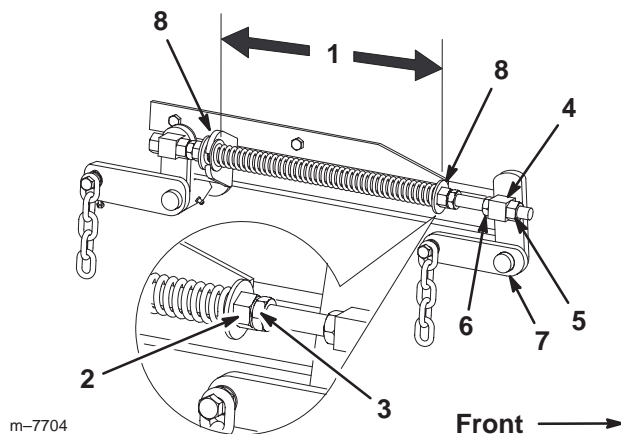

Figure 54

- | | |
|---|----------------------|
| 1. 10-1/2 inch (267 mm) between the large washers | 4. Front swivel |
| 2. Front nut | 5. Swivel jam nut |
| 3. Spring jam nut | 6. Lift nut |
| | 7. Front support arm |
| | 8. Large washer |

- Adjust the lift nuts on both the left and the right side of the machine to achieve **1/4 to 3/8 inch (6 to 10 mm) lower in front at A than in the rear at B** (Fig. 54).
- Tighten both swivel jam nuts against the front swivel to lock the height.
- Check to ensure that there is equal tension on the chains and adjust again if needed.

Adjusting the Compression Spring

- Raise the mower lift lever to the transport position (Fig. 54).
- Check the distance between the 2 large washers; it must be 10-1/4 inches (26.7 cm) (Fig. 54).
- Adjust this distance by loosening the spring jam nut and turning the nut in front of each spring (Fig. 54).

Note: Turning the nut clockwise shortens the spring; turning the nut counterclockwise lengthens the spring.

- Lock the nut into position by tightening the spring jam nut (Fig. 54).

Adjusting the Push Arms

If needed, adjust the push arms to increase or decrease the mower belt tension.

- Loosen the jam nut and rotate the ball joint counterclockwise, one turn at a time. (Fig. 55).

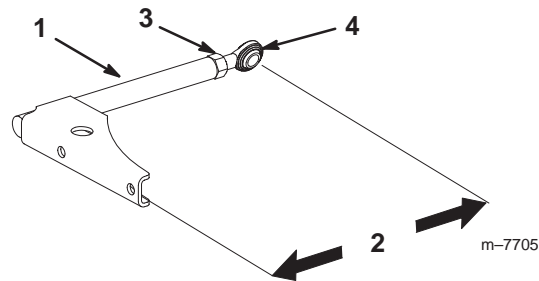

Figure 55

- | | |
|--|---------------|
| 1. Push arm | 3. Jam nut |
| 2. 13-1/2 inch (343 mm) nominal at 15° twist | 4. Ball joint |

- Adjust each side the same amount. Each push arm should have a nominal length of 13-1/2 inch (34 cm) at a 15-degree twist (Fig. 55).

Note: Increase the tension by lengthening the push arms; decrease the tension by shortening the push arms.

Cleaning Under the Mower

Remove grass buildup under the mower housing daily.

- Position the mower on a flat surface.
- Disengage the PTO, move the motion control levers to the neutral locked position, and set the parking brake.
- Stop the engine, remove the key, and wait for all moving parts to stop before leaving the operating position.
- Raise the mower housing to the transport position.
- Lift the front of the machine and support the machine using jack stands.



Danger



Mechanical or hydraulic jacks may fail to support machine and cause a serious injury.

- Use the jack stand when supporting the machine.
- Do not use hydraulic jacks.

Inspecting the Belts

Inspect all belts every 50 hours.

Check belts for cracks, frayed edges, burn marks, or any other damage. Replace damaged belts.

Replacing the Mower Belt

The signs of a worn mower belt are squealing while the belt is rotating, blades slipping while you are cutting grass, frayed belt edges, burn marks, and cracks. Replace the mower belt if you detect any of these signs.

1. Disengage the PTO, move the motion control levers to the neutral locked position, and set the parking brake.
2. Stop the engine, remove the key, and wait for all moving parts to stop before leaving the operating position.
3. Remove the belt covers over the outside spindles.
4. Loosen the fixed idler arm and adjust it to relieve the belt tension on the fixed idler pulley (Fig. 56).

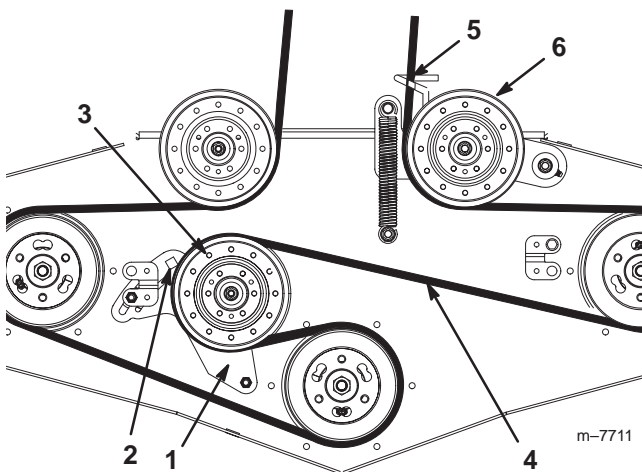

Figure 56

- | | |
|-----------------------|-------------------------------|
| 1. Fixed idler arm | 4. Mower belt |
| 2. Square hole | 5. Belt guide |
| 3. Fixed Idler pulley | 6. Spring-loaded idler pulley |

5. Remove the old belt.
6. Install the new belt through the belt guide and on the pulleys (Fig. 56).

7. Insert a ratchet with a short extension or a breaker bar into the square hole in the fixed idler arm (Fig. 57).

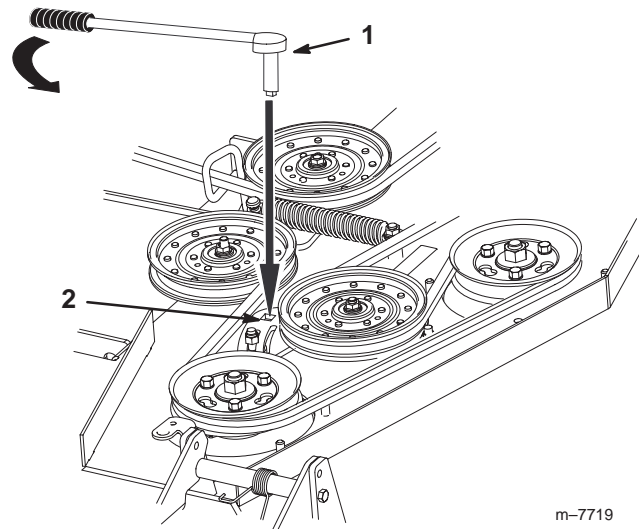

Figure 57

- | | |
|--|----------------|
| 1. Ratchet with short extension or breaker bar | 2. Square hole |
|--|----------------|

8. To increase the belt tension, rotate the ratchet or breaker bar counterclockwise to move the fixed idler arm until you feel increased resistance and the spring-loaded idler pulley stops moving.

Note: Do not increase the belt tension beyond the point where the fixed idler arm stops.

9. While holding the belt in tension, tighten the 2 bolts that secure the fixed idler arm.
10. Remove the ratchet or breaker bar from the square hole in the fixed idler arm.
11. Install the belt covers the outside spindles.

PROTOTYPE

Replacing the Pump Drive Belt

Check the pump drive belt for wear after every 50 operating hours.

1. Remove the mower belt first; refer to Replacing the Mower Belt on page 42.
2. Remove the bolt from the clutch stop and unplug the clutch electrical wire (Fig. 58).

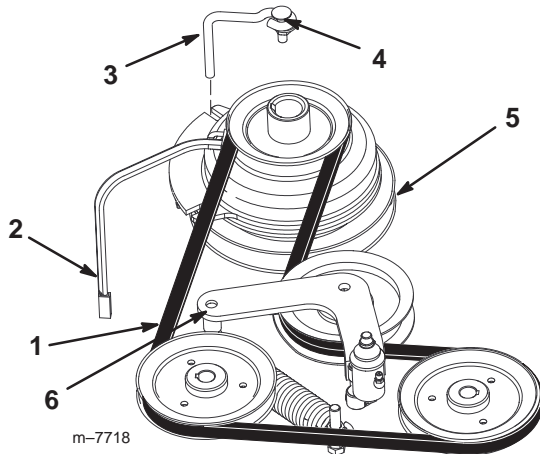

Figure 58

- | | |
|---------------------------|-----------|
| 1. Belt | 4. Bolt |
| 2. Clutch electrical wire | 5. Clutch |
| 3. Clutch stop | 6. Idler |

3. Pull the spring loaded idler to the side.
4. Remove the traction belt from the engine and the hydraulic pump pulleys (Fig. 58).
5. Install the new belt around the engine and the hydraulic pump pulleys (Fig. 58).
6. Pull the spring-loaded idler to the side and align the belt.
7. Release the pressure on the spring loaded idler (Fig. 58).
8. Install the mower belt.

Adjusting the Parking Brake

Check the parking brake for proper adjustment.

1. Disengage the brake lever (lever down).
2. Measure the length of the spring; the measurement should be 2-3/4 inch (74 mm) between the washers (Fig. 59).

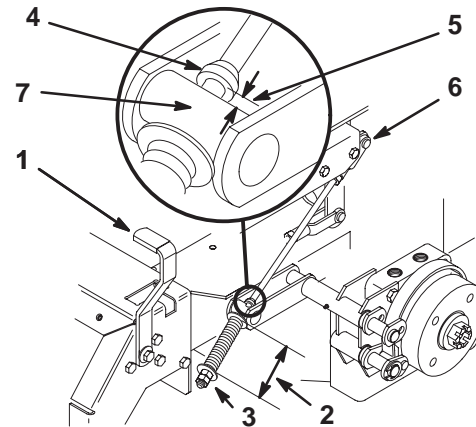

Figure 59

- | | |
|-------------------------------|---------------------------------|
| 1. Brake lever | 5. 3/16 to 1/4 inch (5 to 7 mm) |
| 2. Spring, 2-3/4 inch (74 mm) | 6. Jam nut and yoke |
| 3. Adjusting nuts | 7. Trunnion |
| 4. Collar on brake rod | |

3. If an adjustment is necessary, do the following:
 - A. Loosen the jam nut below the spring and tighten the nut directly below the yoke (Fig. 59).
 - B. Turn the nut until you obtain the correct measurement.
 - C. Tighten the 2 nuts together and repeat on the opposite side of the machine.
4. Turn the nuts clockwise to shorten the spring length; counterclockwise to lengthen the spring.
5. Engage the parking brake, with the lever up.
6. Measure the distance between the trunnion roller and the collar on the brake rod. The measurement should be 3/16 to 1/4 inch (5 to 7 mm) (Fig. 59).
7. If an adjustment is necessary, do the following:
 - A. Loosen the jam nut directly below the yoke.
 - B. Turn the bottom adjusting nuts until the correct measurement is obtained (Fig. 59).
 - C. Tighten the jam nut at the yoke.

Servicing the Fuses

Service Interval/Specification

The electrical system is protected by fuses. It requires no maintenance; however, if a fuse blows, check the component/circuit for a malfunction or short.

Fuse: Main F1—30 amp, blade-type
Charge Circuit F2—25 amp, blade-type
Optional Headlight Kit—10 amp, blade type

1. Raise the seat to gain access to the fuse holder (Fig. 60).

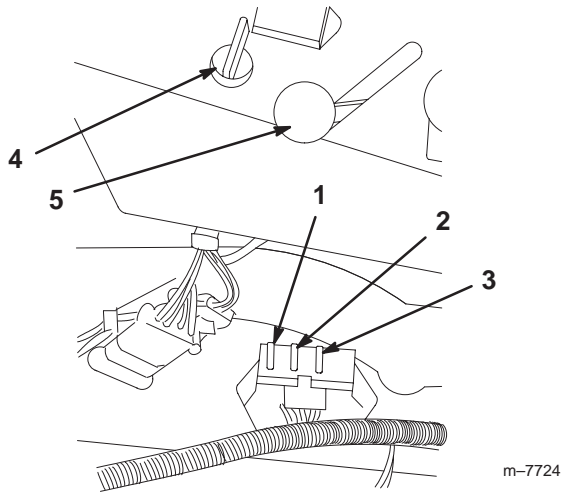

Figure 60

1. Main—30 amp
2. Charge circuit—25 amp
3. For optional Headlight Kit—10 amp
4. Ignition switch
5. Throttle lever

2. To replace a fuse, pull out on the fuse to remove it (Fig. 60).

Servicing the Battery



Warning



CALIFORNIA

Proposition 65 Warning

Battery posts, terminals, and related accessories contain lead and lead compounds, chemicals known to the State of California to cause cancer and reproductive harm. *Wash hands after handling.*

Checking the Electrolyte Level

1. Shut off the engine and wait for all moving parts to stop.
2. Open the hood.
3. Look at the side of the battery. The electrolyte must be up to the **upper** line (Fig. 61).

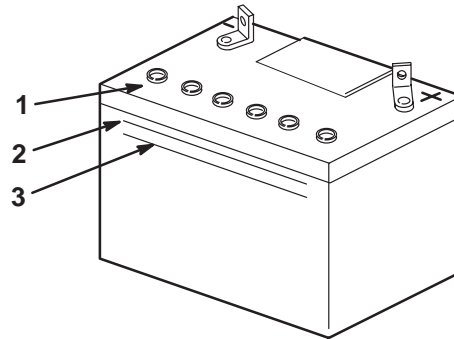

Figure 61

1. Filler caps
2. **Upper** line
3. **Lower** line

Note: Do not allow the electrolyte to get below the **lower** line (Fig. 61).

4. If the electrolyte is low, add the required amount of distilled water; refer to Adding Water to the Battery on page 46.

Installing the Battery

1. Position the battery in the tray with the terminal posts toward the engine (Fig. 62).

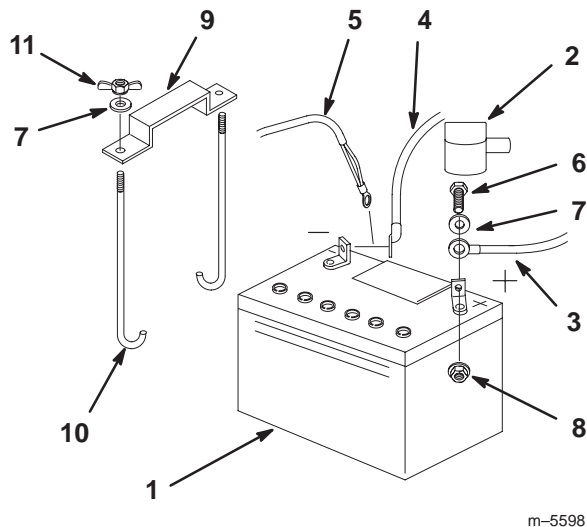

Figure 62

- | | |
|---------------------------|------------------------|
| 1. Battery | 7. Washer, 1/4 inch |
| 2. Terminal boot | 8. Locknut, 1/4 inch |
| 3. Positive battery cable | 9. Battery clamp |
| 4. Negative battery cable | 10. J-bolts |
| 5. Ground wire | 11. Wing nut, 1/4 inch |
| 6. Bolt, 1/4 x 3/4 inch | |

2. First, install the positive (red) battery cable to the positive (+) battery terminal.
3. Then install the negative battery cable and the ground wire to the negative (-) battery terminal.
4. Secure the cables with 2 bolts (1/4 x 3/4 inch), 2 washers (1/4 inch), and 2 locknuts (1/4 inch) (Fig. 62).
5. Slide the red terminal boot onto the positive (red) battery post.
6. Secure the battery with J-bolts, clamp, 2 washers (1/4 inch), and 2 wing nuts (1/4 inch) (Fig. 62).

Removing the Battery



Warning



The battery terminals or metal tools could short against metal machine components, causing sparks. Sparks can cause the battery gasses to explode, resulting in personal injury.

- When removing or installing the battery, do not allow the battery terminals to touch any metal parts of the machine.
- Do not allow metal tools to short between the battery terminals and metal parts of the machine.



Warning



Incorrectly routing the battery cable could damage the machine and cables, causing sparks. Sparks can cause the battery gasses to explode, resulting in personal injury.

- Always *disconnect* the negative (black) battery cable before disconnecting the positive (red) cable.
- Always *connect* the positive (red) battery cable before connecting the negative (black) cable.

1. Disengage the PTO, move the motion control levers to the neutral locked position, and set the parking brake.
2. Stop the engine, remove the key, and wait for all moving parts to stop before leaving the operating position.
3. Tilt the seat up.
4. Disconnect the negative battery cable and the ground wire from the negative (-) battery terminal (Fig. 62).
5. Slide the red terminal boot off the positive (red) battery terminal.
6. Remove the positive (red) battery cable (Fig. 62).
7. Remove both wing nuts (1/4 inch) that secure the battery clamp (Fig. 62).
8. Remove the battery.

PROTOTYPE

Adding Water to the Battery

The best time to add distilled water to the battery is just before you operate the machine. This lets the water mix thoroughly with the electrolyte solution.

Note: Never fill the battery with distilled water while the battery installed in the machine. The electrolyte could be spilled on other parts and cause corrosion.

1. Remove the battery from the machine.
2. Clean the top of the battery with a paper towel.
3. Remove the vent caps from the battery (Fig. 61).
4. Slowly pour distilled water into each battery cell until the level is up to the **upper** line (Fig. 61) on the battery case.

Important Do not overfill the battery because electrolyte (sulfuric acid) can cause severe corrosion and damage to the chassis.

5. Wait 5 to 10 minutes after filling the battery cells, then add distilled water, if necessary, until the electrolyte level is up to the **upper** line (Fig. 61) on the battery case.
6. Install battery vent caps.

Charging the Battery



Warning



Charging the battery produces gasses that can explode.

Never smoke near the battery, and keep sparks and flames away from the battery.

Important Always keep the battery fully charged (1.265 specific gravity). This is especially important to prevent battery damage when the temperature is below 32°F (0°C).

1. Remove the battery from the chassis; refer to Removing the Battery on page 45.
2. Ensure that the filler caps are installed in battery.
3. Charge battery for a minimum of 1 hour at 6 to 10 amps.

4. When the battery is fully charged, unplug the charger from the electrical outlet, then disconnect the charger leads from the battery posts (Fig. 63).

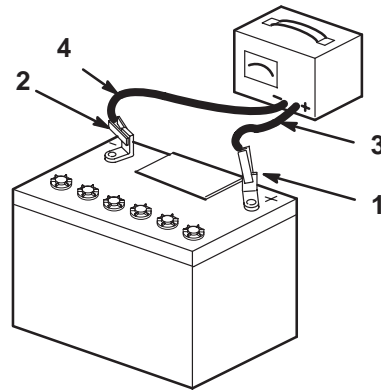

m-4970

Figure 63

1. Positive Battery Post
2. Negative Battery Post
3. Red (+) Charger Lead
4. Black (-) Charger Lead

5. Install the battery in the machine and connect the battery cables; refer to Installing the Battery on page 45.

Note: Do not run the machine with the battery disconnected to prevent electrical damage.

PROTOTYPE

Replacing the Grass Deflector

Warning

An uncovered discharge opening could allow the lawn mower to throw objects in the operator's or bystander's direction and result in serious injury. Also, contact with the blade could occur.

- **Never operate the lawn mower unless you install a cover plate, a mulch plate, or a grass chute and catcher.**
- **Ensure that the grass deflector is in the down position.**

1. Remove the locknut, bolt, spring, and spacer that hold the deflector to the pivot brackets (Fig. 64).

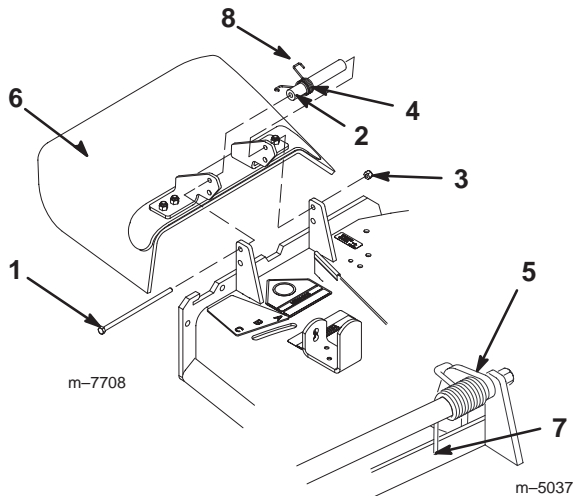

Figure 64

- | | |
|---------------------|---|
| 1. Bolt | 6. Grass deflector |
| 2. Spacer | 7. Place behind mower housing edge before installing bolt |
| 3. Locknut | 8. Hook end of spring |
| 4. Spring | |
| 5. Spring installed | |

2. Remove the damaged or worn grass deflector.
3. Place the spacer and spring onto the grass deflector.
4. Install the bolt and nut.
5. Place the hook end of the spring around the grass deflector (Fig. 64).

Important The grass deflector must be able to lower down into position. Lift the deflector up to ensure that it lowers into the full down position.

Waste Disposal

Engine oil, hydraulic oil, engine coolant, and the battery are pollutants to the environment. Dispose of these according to your local regulations.

PROTOTYPE

Wiring Diagram

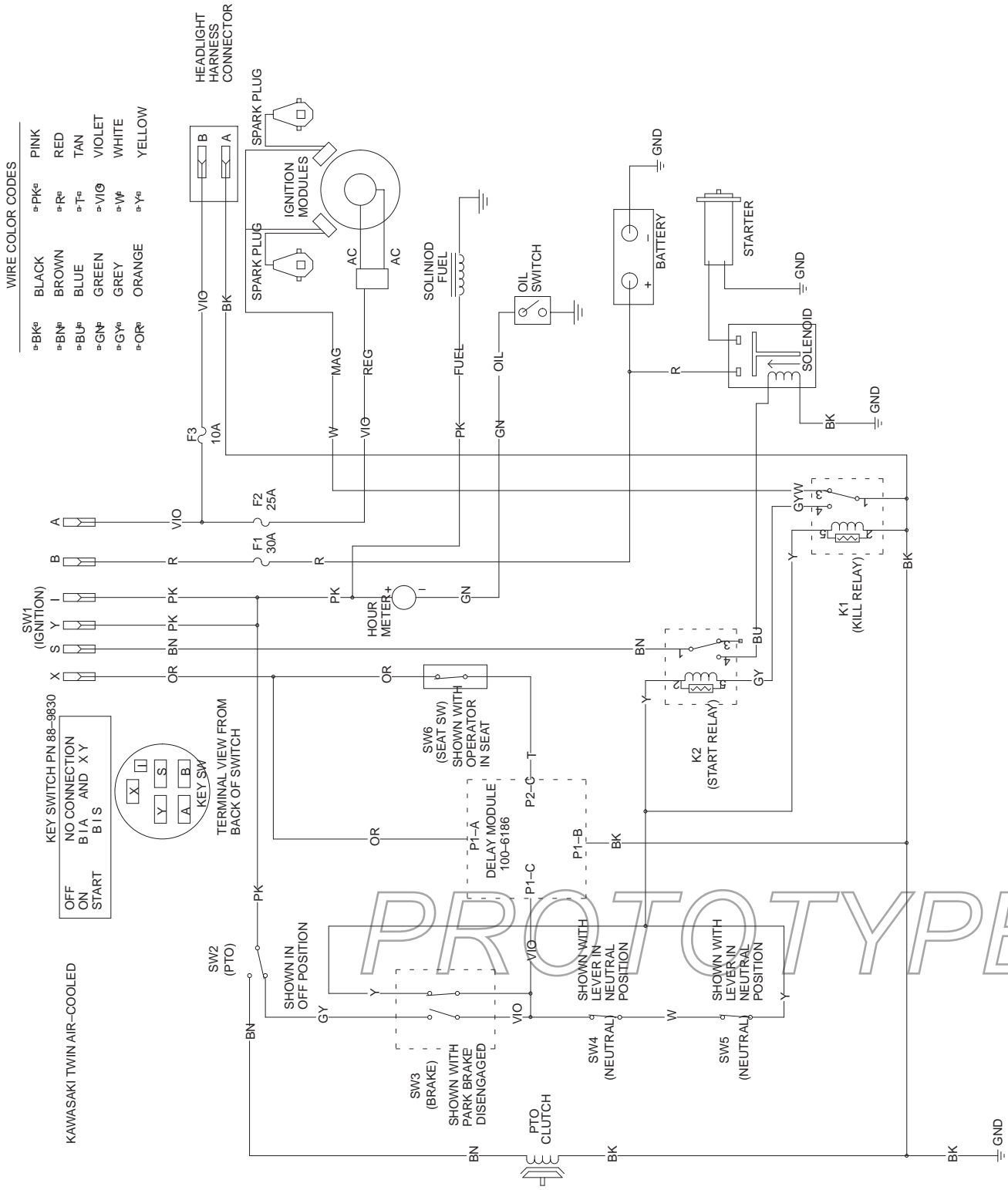

Cleaning and Storage

1. Disengage the power takeoff (PTO), set the parking brake and turn the ignition key to off. Remove spark plug wire. Remove the key.
2. Remove grass clippings, dirt, and grime from the external parts of the entire machine, especially the engine and hydraulic system. Clean dirt and chaff from the outside of the engine's cylinder head fins and blower housing.

Important You can wash the machine with mild detergent and water. Do not pressure wash the machine. Avoid excessive use of water, especially near the control panel, engine, hydraulic pumps and motors.

3. Service the air cleaner; refer to Servicing the Air Cleaner on page 29.
4. Grease and oil the machine; refer to Greasing and Lubrication on page 33.
5. Change the crankcase oil and filter; refer to Servicing the Engine Oil on page 30.
6. Change the hydraulic filter; refer to Servicing the Hydraulic System on page 34.
7. Check the tire pressure; refer to Checking the Tire Pressure on page 34.
8. Charge the battery; refer to Servicing the Battery page 44.
9. Scrape any heavy buildup of grass and dirt from the underside of the mower, then wash the mower with a garden hose.

Note: Run the machine with the PTO engaged and the engine at high idle for 2 to 5 minutes after washing.

10. Check the condition of the blades. Refer to Servicing the Cutting Blades on page 26.
11. Prepare the machine for storage when nonuse occurs over 30 days. Prepare machine for storage as follows.

- A. Add a petroleum based stabilizer/conditioner to fuel in the tank. Follow mixing instructions from stabilizer manufacture. **Do not use an alcohol based stabilizer (ethanol or methanol).**

Note: A fuel stabilizer/conditioner is most effective when mixed with fresh gasoline and used at all times.

- B. Run engine to distribute conditioned fuel through the fuel system (5 minutes).
- C. Stop engine, allow to cool and drain the fuel tank; refer to Servicing the Fuel Tank on page 32.
- D. Restart engine and run it until it stops.
- E. Choke the engine. Start and run engine until it will not start.
- F. Dispose of fuel properly. Recycle as per local codes.

Important Do not store stabilizer/conditioned gasoline over 90 days.

12. Remove the spark plug(s) and check its condition; refer to Servicing the Spark Plug(s) on page 31. With the spark plug(s) removed from the engine, pour 2 tablespoons of engine oil into the spark plug hole. Now use the starter to crank the engine and distribute the oil inside the cylinder. Install the spark plug(s). Do not install the wire on the spark plug(s).
13. Check and tighten all bolts, nuts, and screws. Repair or replace any part that is damaged or defective.
14. Paint all scratched or bare metal surfaces. Paint is available from your Authorized Service Dealer.
15. Store the machine in a clean, dry garage or storage area. Remove the key from the ignition switch and keep it in a memorable place out of reach of children or other unauthorized users. Cover the machine to protect it and keep it clean.

PROTOTYPE

Troubleshooting

Problem	Possible Causes	Corrective Action
Starter does not crank.	<ol style="list-style-type: none"> 1. Blade control (PTO) is engaged. 2. Parking brake is not on. 3. Operator is not seated. 4. Battery is dead. 5. Electrical connections are corroded or loose. 6. Fuse is blown. 7. Relay or switch is defective. 	<ol style="list-style-type: none"> 1. Move blade control (PTO) to Disengaged. 2. Set parking brake. 3. Sit on the seat. 4. Charge the battery. 5. Check electrical connections for good contact. 6. Replace fuse. 7. Contact Authorized Service Dealer.
Engine will not start, starts hard, or fails to keep running.	<ol style="list-style-type: none"> 1. Fuel tank is empty. 2. Fuel valve turned off. 3. Choke is not on. 4. Air cleaner is dirty. 5. Spark plug wires are loose or disconnected. 6. Spark plugs are pitted, fouled, or gap is incorrect. 7. Dirt in fuel filter. 8. Dirt, water, or stale fuel is in fuel system. 	<ol style="list-style-type: none"> 1. Fill fuel tank with gasoline. 2. Open fuel valve. 3. Move choke lever to on. 4. Clean or replace air cleaner element. 5. Install wires on spark plug. 6. Install new, correctly gapped spark plugs. 7. Replace fuel filter. 8. Contact Authorized Service Dealer.
Engine loses power.	<ol style="list-style-type: none"> 1. Engine load is excessive. 2. Air cleaner is dirty. 3. Oil level in crankcase is low. 4. Cooling fins and air passages under engine blower housing are plugged. 5. Spark plugs are pitted, fouled, or gap is incorrect. 6. Dirt in fuel filter. 7. Dirt, water, or stale fuel is in fuel system. 	<ol style="list-style-type: none"> 1. Reduce ground speed. 2. Clean air cleaner element. 3. Add oil to crankcase. 4. Remove obstruction from cooling fins and air passages. 5. Install new, correctly gapped spark plugs. 6. Replace fuel filter. 7. Contact Authorized Service Dealer.
Engine overheats.	<ol style="list-style-type: none"> 1. Engine load is excessive. 2. Oil level in crankcase is low. 3. Cooling fins and air passages under engine blower housing are plugged. 	<ol style="list-style-type: none"> 1. Reduce ground speed. 2. Add oil to crankcase. 3. Remove obstruction from cooling fins and air passages.

Problem	Possible Causes	Corrective Action
Machine does not drive.	<ol style="list-style-type: none"> 1. Traction belt is worn, loose or broken. 2. Traction belt is off pulley. 3. Hydro fluid level low. 	<ol style="list-style-type: none"> 1. Contact Authorized Service Dealer. 2. Contact Authorized Service Dealer. 3. Add hydro fluid to reservoir.
Abnormal vibration.	<ol style="list-style-type: none"> 1. Engine mounting bolts are loose. 2. Loose engine pulley, idler pulley, or blade pulley. 3. Engine pulley is damaged. 4. Cutting blade(s) is/are bent or unbalanced. 5. Blade mounting bolt is loose. 6. Engine mounting bolts are loose. 7. Loose engine pulley, idler pulley, or blade pulley. 8. Engine pulley is damaged. 9. Blade spindle bent. 	<ol style="list-style-type: none"> 1. Tighten engine mounting bolts. 2. Tighten the appropriate pulley. 3. Contact Authorized Service Dealer. 4. Install new cutting blade(s). 5. Tighten blade mounting bolt. 6. Tighten engine mounting bolts. 7. Tighten the appropriate pulley. 8. Contact Authorized Service Dealer. 9. Contact Authorized Service Dealer.
Uneven cutting height.	<ol style="list-style-type: none"> 1. Blade(s) not sharp. 2. Cutting blade(s) is/are bent. 3. Mower is not level. 4. Gage wheel not set correctly. 5. Underside of mower is dirty. 6. Tire pressure is incorrect. 7. Blade spindle bent. 	<ol style="list-style-type: none"> 1. Sharpen blade(s). 2. Install new cutting blade(s). 3. Level mower from side-to-side and front-to-rear. 4. Adjust gage wheel height. 5. Clean the underside of the mower. 6. Adjust tire pressure. 7. Contact Authorized Service Dealer.
Blades do not rotate.	<ol style="list-style-type: none"> 1. Mower belt is off the pulley. 2. Mower belt is worn, loose or broken. 3. Electric clutch does not engage. 4. Electric clutch is worn. 	<ol style="list-style-type: none"> 1. Install the mower belt and check the adjusting plate, idler arm and spring, and belt guides for correct position 2. Install a new mower belt. 3. Contact Authorized Service Dealer. 4. Contact Authorized Service Dealer.



LCE

The Toro Total Coverage Guarantee

A Limited Warranty

Conditions and Products Covered

The Toro Company and its affiliate, Toro Warranty Company, pursuant to an agreement between them, jointly promise to repair the listed Toro Products if defective in materials or workmanship. The following time periods apply from the date of purchase:

<u>Products</u>	<u>Warranty Period</u>
• All Products	1 year
• All Spindles	2 years parts and labor; third year, parts only
• Engines/Hydraulic Systems* on the following: Outfront and Mid-Mount Z's ProLine Mid-Size Mowers Groundsmaster® Riding Mowers Backpack Blowers	2 years
• Deck Shells (36"–72") on the following: ProLine Mid-Size Mowers Mid-Mount Z's	2 years
• Electric Clutch on 200 Series Mid-Mount Z's	2 years

This warranty includes the cost of parts and labor, but you must pay transportation costs.

This warranty applies to:

- Outfront and Mid-Mount Z's
- ProLine Mid-Size Mowers
- Groundsmaster Riding Mowers
- Turf Maintenance Equipment
- Debris Management Equipment

* Some engines used on Toro LCE Products are warranted by the engine manufacturer.

Instructions for Obtaining Warranty Service

If you think that your Toro Product contains a defect in materials or workmanship, follow this procedure:

1. Contact any Toro Authorized or Master Service Dealer to arrange service at their dealership. To locate a dealer convenient to you, access our website at www.Toro.com. U.S. Customers may also call 800-348-2424.
2. Bring the product and your proof of purchase (sales receipt) to the Service Dealer.

If for any reason you are dissatisfied with the Service Dealer's analysis or with the assistance provided, contact us at:

LCB Customer Service Department
Toro Warranty Company
8111 Lyndale Avenue South
Bloomington, MN 55420-1196
888-577-7466 (U.S. customers)
877-484-9255 (Canada customers)

Countries Other than the United States or Canada

Customers who have purchased Toro products exported from the United States or Canada should contact their Toro Distributor (Dealer) to obtain guarantee policies for your country, province, or state. If for any reason you are dissatisfied with your Distributor's service or have difficulty obtaining guarantee information, contact the Toro importer. If all other remedies fail, you may contact us at Toro Warranty Company.

Owner Responsibilities

You must maintain your Toro Product by following the maintenance procedures described in the operator's manual. Such routine maintenance, whether performed by a dealer or by you, is at your expense.

Items and Conditions Not Covered

There is no other express warranty except for special emission system coverage on some products. This express warranty does not cover the following:

- Cost of regular maintenance service or parts, such as filters, fuel, lubricants, tune-up parts, blade sharpening, brake and clutch adjustments.
- Any product or part which has been altered or misused or required replacement or repair due to normal wear, accidents, or lack of proper maintenance.
- Repairs necessary due to improper fuel, contaminants in the fuel system, or failure to properly prepare the fuel system prior to any period of non-use over three months.
- Pickup and delivery charges.

All repairs covered by this warranty must be performed by an Authorized Toro Service Dealer using Toro approved replacement parts.

General Conditions

Repair by an Authorized Toro Service Dealer is your sole remedy under this warranty.

Neither The Toro Company nor Toro Warranty Company is liable for indirect, incidental or consequential damages in connection with the use of the Toro Products covered by this warranty, including any cost or expense of providing substitute equipment or service during reasonable periods of malfunction or non-use pending completion of repairs under this warranty.

Some states do not allow exclusions of incidental or consequential damages, or limitations on how long an implied warranty lasts, so the above exclusions and limitations may not apply to you.

All implied warranties of merchantability (that the product is fit for ordinary use) and fitness for use (that the product is fit for a particular purpose) are limited to the duration of the express warranty.

This warranty gives you specific legal rights, and you may also have other rights which vary from state to state.

