



44'' and 52'' Twin Soft Bagger

Z100 and Z400 Series Z Master

Model No. 78507—Serial No. 230000001 and Up

Operator's Manual

Contents

	Page
Introduction	2
Safety	3
Safety and Instruction Decals	4
Setup	5
Loose Parts	5
Installing the Bagger Bracket	6
Installing the Blower Assembly	9
Installing the Bagger Belt and Idler Spring	10
Installing the Hood Assembly and Bags	13
Installing the Bagger Tube	15
Operation	16
Emptying the Grass Bags	16
Clearing Obstructions From the Bagger System ..	17
Removing the Bagger	17
Using the Grass Deflector	17
Operating and Bagging Tips	18
Maintenance	19
Recommended Maintenance Schedule	19
Cleaning the Hood Screen	19
Cleaning the Bagger	19
Checking and Adjusting the Bagger Belt Tension	20
Checking and Adjusting the Blower Latch	21
Replacing the Blower Belt	22
Greasing the Idler Arm	22
Checking the Blower Liner	23
Replacing the Blower Liner	23
Inspecting the Bagger	24
Inspecting the Mower Blades and Baffles	24
Installing Mower Blades	24
Installing the Grass Deflector	24
Storage	26
Troubleshooting	27

Introduction

Read this manual carefully to learn how to operate and maintain your product properly. The information in this manual can help you and others avoid injury and product damage. Although Toro designs and produces safe products, you are responsible for operating the product properly and safely.

You may contact Toro directly at www.Toro.com for product and accessory information, help finding a dealer, or to register your product.

Whenever you need service, genuine Toro parts, or additional information, contact an Authorized Service Dealer or Toro Customer Service and have the model and

serial numbers of your product ready. Figure 1 illustrates the location of the model and serial numbers on the product.

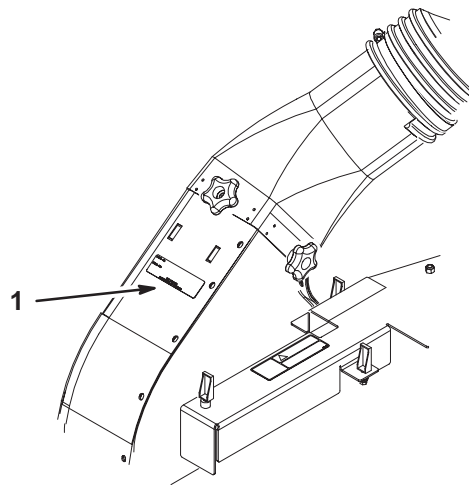

m-6231

Figure 1

1. Location of the model and serial numbers

Write the product model and serial numbers in the space below:

Model No. _____
Serial No. _____

This manual identifies potential hazards and has special safety messages that help you and others avoid personal injury and even death. **Danger**, **Warning**, and **Caution** are signal words used to identify the level of hazard. However, regardless of the hazard, be extremely careful.

Danger signals an extreme hazard that *will* cause serious injury or death if you do not follow the recommended precautions.

Warning signals a hazard that *may* cause serious injury or death if you do not follow the recommended precautions.

Caution signals a hazard that may cause minor or moderate injury if you do not follow the recommended precautions.

This manual uses two other words to highlight information.

Important calls attention to special mechanical information and **Note:** emphasizes general information worthy of special attention.

Safety

The following list contains safety information specific to Toro products and other safety information you must know.

- Become familiar with the safe operation of the equipment, with the operator controls, and safety signs.
- Use extra care with grass catchers or other attachments. These can change the operating characteristics and the stability of the machine.
- Do not use a grass catcher on steep slopes. A heavy grass catcher could cause loss of control or overturn the machine.
- Slow down and use extra care on hillsides. Be sure to travel in the recommended direction on hillsides. Turf conditions can affect the machine's stability. Use extreme caution while operating near drop-offs.
- Keep all movement on slopes slow and gradual. Do not make sudden changes in speed, directions or turning.
- The grass catcher can obstruct the view to the rear. Use extra care when operating in reverse.
- Use care when loading or unloading the machine into a trailer or truck
- Never operate with the discharge deflector raised or removed and never altered, unless using a grass catcher or mulching baffles.
- Keep hands and feet away from moving parts. Do not make adjustments with the engine running.
- Stop on level ground, disengage drives, set the parking brake, shut off the engine before leaving the operator's position for any reason including emptying the grass catcher or unclogging the chute.
- If you remove the grass catcher, be sure to install any discharge deflector or guard that might have been removed to install the grass catcher. Do not operate the mower without either the entire grass catcher or the grass deflector in place.
- **Turn off the engine and wait for all moving parts to stop before removing the grass catcher or unclogging the chute.**
- Do not use your hands to unclog the chute, blower or bagger.
- Do not leave grass in grass catcher for extended periods of time.
- Grass catcher components are subject to wear, damage and deterioration, which could expose moving parts or allow objects to be thrown. Frequently check components and replace with manufacturer's recommended parts, when necessary.

Safety and Instruction Decals



Safety decals and instructions are easily visible to the operator and are located near any area of potential danger. Replace any decal that is damaged or lost.



79-0350

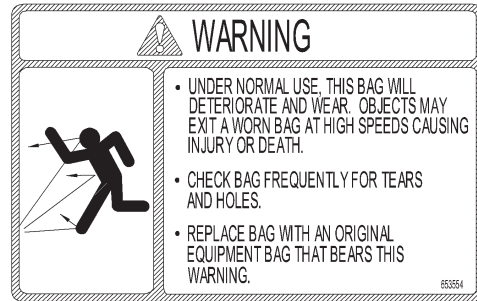

1-653554

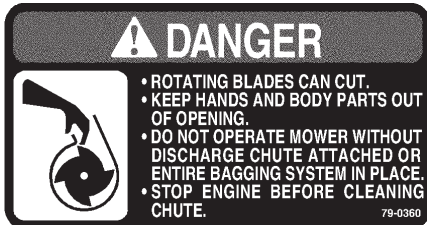

79-0360



106-0871



80-8040



98-4387



88-8950

1. Warning—wear hearing protection.



93-1122

Setup

Note: Determine the left and right sides of the machine from the normal operating position.

Loose Parts

Note: Use the chart below to verify all parts have been shipped.

Step	Description	Qty.	Use
1	Bagger bracket	1	Installing bagger bracket
	Bolt, 5/16 x 1 inch	8	
	Flange nut, 5/16 inch	8	
2	Blower assembly	1	Installing the blower assembly
3	Blower belt cover	1	Installing the bagger belt and idler spring
	Idler spring	1	
	Bagger belt	1	
4	Hood assembly	1	Installing the hood assembly and bags
	Bag	2	
	Clevis pin	2	
	Hairpin cotter	2	
5	Bagger tube	1	Installing the bagger tube
	Clamp	1	
	Knob	2	
	Blower adapter	1	

Important Bagger model 78455 MUST be paired with either model 78496 or 78497 finishing kit. Bagger model 78507 MUST be paired with either model 78508 or 78509 finishing kit. Failure to match the appropriate finishing kit with the appropriate bagger will result in misalignment of the blower assembly relative to the deck, as well as misalignment of the latch components, and potential interference between the blower inlet shelf and the deck baffles.

Step

1

Parts needed for this step:

- 1 Bagger bracket
- 8 Bolts, 5/16 x 1 inch
- 8 Flange nuts, 5/16 inch

Installing the Bagger Bracket

Note: Determine if machine is equipped with a back mount or back and side mount heat shield. If machine is equipped with a back mount heat shield (Fig. 3), use steps 1 thru 3. If machine has a back and side mount heat shield (Fig. 4), proceed to step 4.

1. Remove the rear heat shield (Fig. 2). Discard the bolts and nuts.

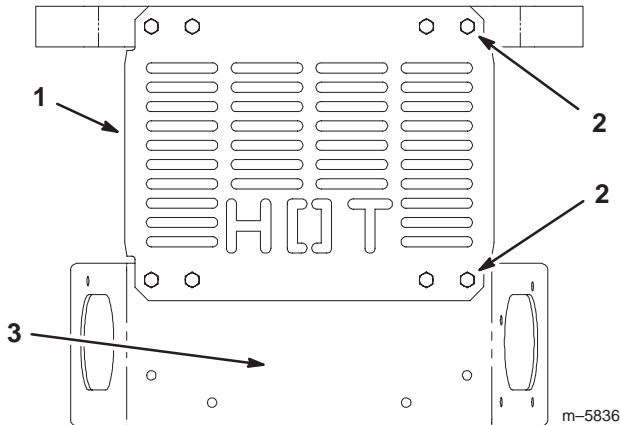

Figure 2

1. Rear heat shield
2. Bolts—remove and discard
3. Rear bumper

2. Position the bagger bracket behind the engine guard straps and rear bumper (Fig. 3).
3. Install the bagger bracket and rear heat shield to the engine guard straps and rear bumper with 8 bolts (5/16 x 1 inch) and 8 flange nuts (5/16 inch) (Fig. 3).

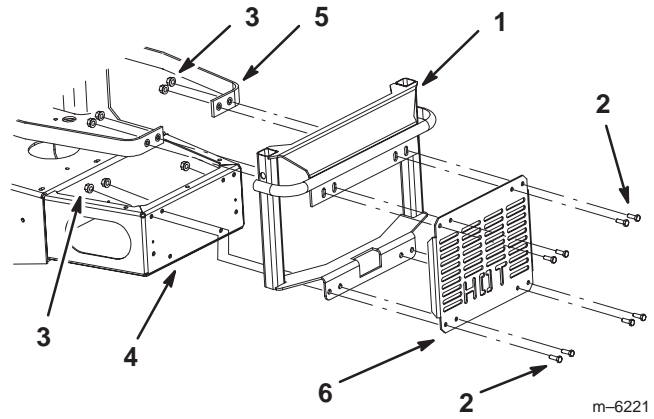

Figure 3

1. Bagger bracket
2. Bolt, 5/16 x 1 inch
3. Flange nut, 5/16 inch
4. Rear bumper
5. Engine guard strap
6. Rear heat shield

4. Remove the 8 bolts and nuts securing the rear of the heat shield to the engine straps and rear bumper (Fig. 4). Discard the bolts and nuts.
5. Remove the 4 bolts, washers and nuts securing the sides of the heat shield to the engine straps, tailpipe guard and bumper. Retain the heat shield and these bolts, washers and nuts (Fig. 4).

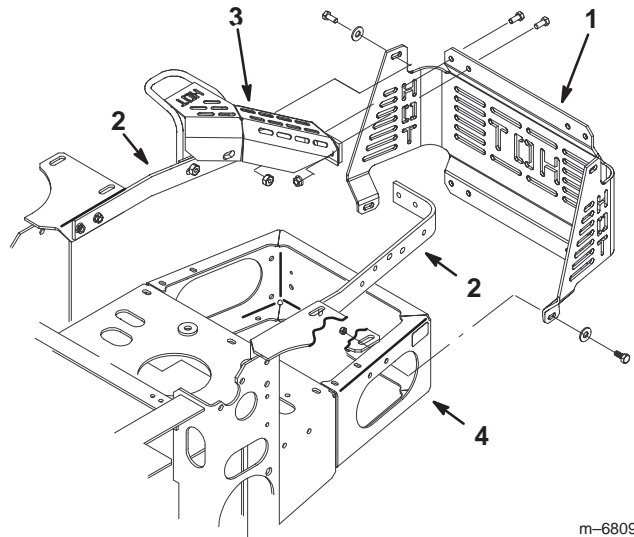

Figure 4

1. Heat shield
2. Engine straps
3. Tailpipe guard
4. Rear bumper

Note: Install the heat shield into the bagger bracket from the **front** of the bracket.

- At an angle, insert the top of the heat shield under the bar of the bagger bracket. Position the bagger bar as far as possible into the heat shield notches (Fig. 5).

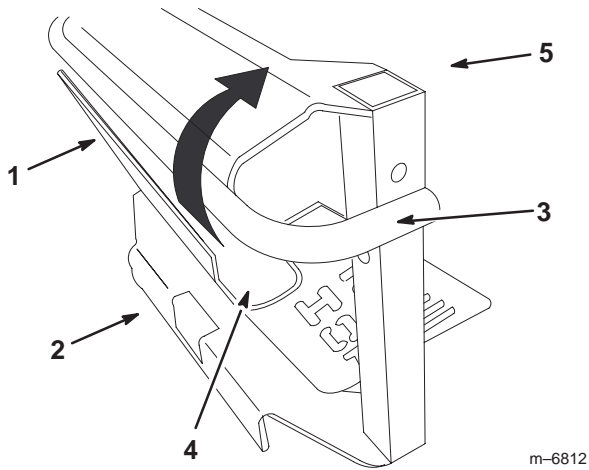

Figure 5

- | | |
|-------------------|----------------------------|
| 1. Heat shield | 4. Heat shield notch |
| 2. Bagger bracket | 5. Front of bagger bracket |
| 3. Bar | |

- With the bagger bar in the heat shield notches, push the bottom of the heat shield towards the rear and past the back of the bagger bracket (Fig. 6).

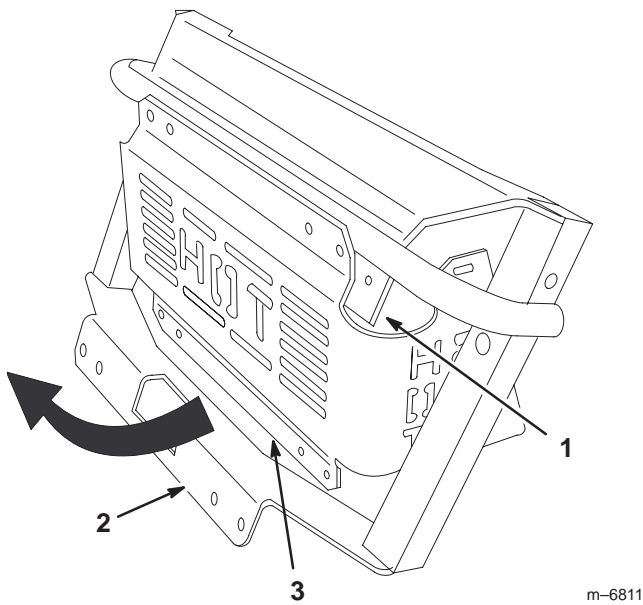

Figure 6

- | | |
|----------------------|--------------------------|
| 1. Heat shield notch | 3. Bottom of heat shield |
| 2. Back of bagger | |

- Slide the heat shield down until the holes align with the bagger bracket holes (Fig. 7).

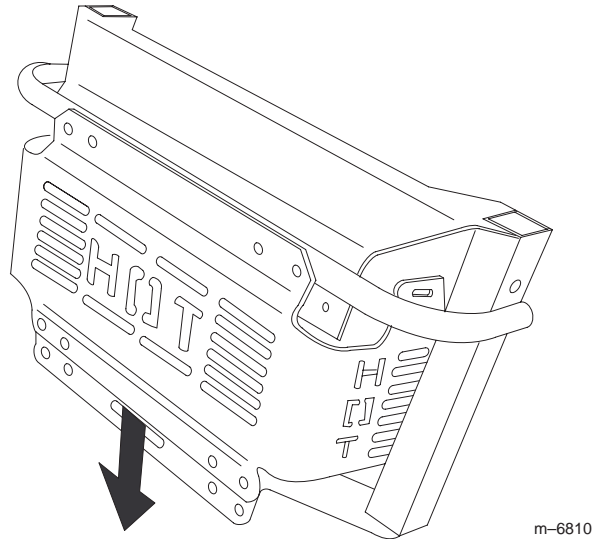

Figure 7

Note: Make sure to install the bagger bracket correctly, as shown in figure 8.

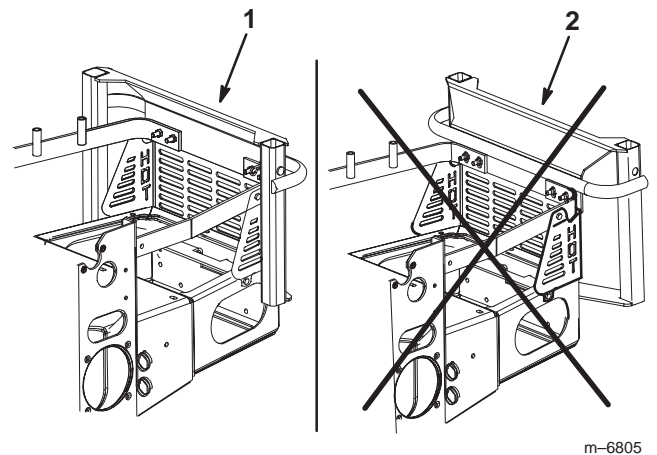
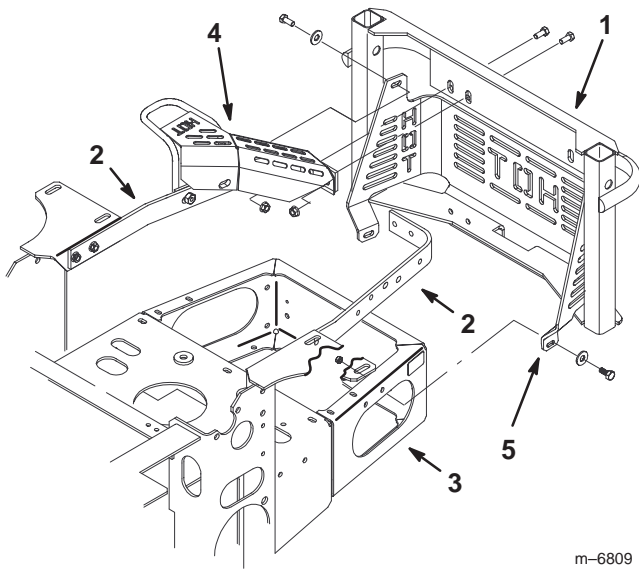

Figure 8

- | | |
|---------------------|-----------------------|
| 1. Correct position | 2. Incorrect position |
|---------------------|-----------------------|

- Install the bagger bracket and heat shield to the engine straps and rear bumper with 8 new bolts (5/16 x 1 inch) and 8 new flange nuts (5/16 inch) (Fig. 9).

- Install the bagger bracket and heat shield to the engine straps, tailpipe guard and rear bumper with 4 bolts, 4 washers and 4 flange nuts, previously removed (Fig. 9).



m-6809

Figure 9

- 1. Bagger bracket
- 2. Engine straps
- 3. Rear bumper
- 4. Tailpipe guard
- 5. Heat shield

Step 2

5. Check if the latch **fully engages** the front latch peg.
Refer to Checking and Adjusting the Blower Latch on page 21.

Note: There must **not** be any gap between the blower assembly and the mounting plate.

Parts needed for this step:

- 1 Blower assembly

Installing the Blower Assembly

Important Make sure the mounting plate is installed to the mower. Refer to the Finishing Kit.

1. Disengage the PTO, set the parking brake, and chock or block the drive wheels.
2. Turn off the engine, remove the key, and wait for all moving parts to stop before leaving the operating position.
3. Slide the blower assembly peg into the hole on the mounting plate (Fig. 10).

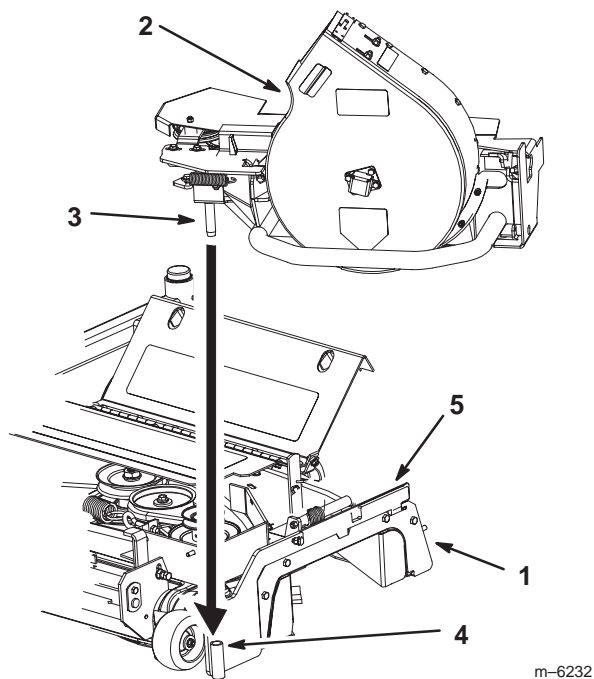

Figure 10

- | | |
|------------------------|------------------------|
| 1. Mower | 4. Mounting plate hole |
| 2. Blower assembly | 5. Mounting plate |
| 3. Blower assembly peg | |

4. Close the blower assembly. (Fig. 14).

Step

3

Parts needed for this step:

- 1 Blower belt cover
- 1 Idler spring
- 1 Bagger belt

Installing the Bagger Belt and Idler Spring

Important The idler spring and bagger belt need to be installed together.

This will create slight tension on both the spring and belt while installing them.

Installing the Idler Spring

1. Disengage the PTO, set the parking brake, and chock or block the drive wheels.
2. Turn off the engine, remove the key, and wait for all moving parts to stop before leaving the operating position.
3. Open the blower assembly (Fig. 13).
4. Slide the spring into the blower eye bolt (Fig. 11).
5. Install the spring into the idler arm eye bolt (Fig. 11).
6. Close the blower assembly (Fig. 14).

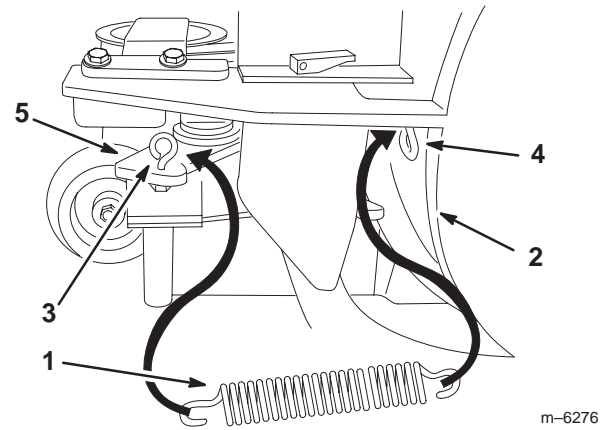

Figure 11

1. Idler spring
2. Blower assembly
3. Idler arm eye bolt
4. Blower eye bolt
5. Idler arm

Installing the Bagger Belt

Note: For 44 inch (112 cm) mowers, make sure the right rear corner of the cover side plate is modified. Refer to the mower Finishing Kit.

1. Disengage the PTO, set the parking brake, and chock or block the drive wheels.
2. Turn off the engine, remove the key, and wait for all moving parts to stop before leaving the operating position.
3. Lower the deck to the 3 inch height-of-cut.
4. Push down on the front latch (colored red) and open the blower assembly (Fig. 13).
5. **For 52 inch mowers only**, loosely install the belt cover, insert the bagger belt under the belt cover and onto the top mower pulley. Secure the belt cover latch (Fig. 12).

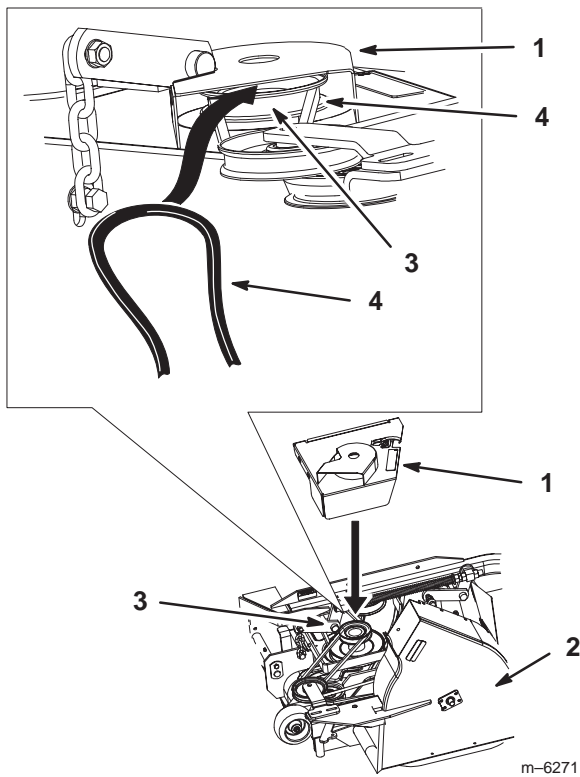

Figure 12

- | | |
|-----------------------------|---------------------|
| 1. 52 inch mower belt cover | 3. Top mower pulley |
| 2. Blower assembly | 4. Bagger belt |

6. Route the bagger belt around the **top pulley of the mower pulley assembly** (Fig. 13).
7. Feed the belt between the idler pulleys (Fig. 13).
8. Route the bagger belt around the **spring-loaded idler pulley** (Fig. 13). The backside of belt will be touching the pulley.
9. Route the bagger belt around the **fixed idler pulley** (Fig. 13).
10. Route the bagger belt around the **blower pulley** (Fig. 13).

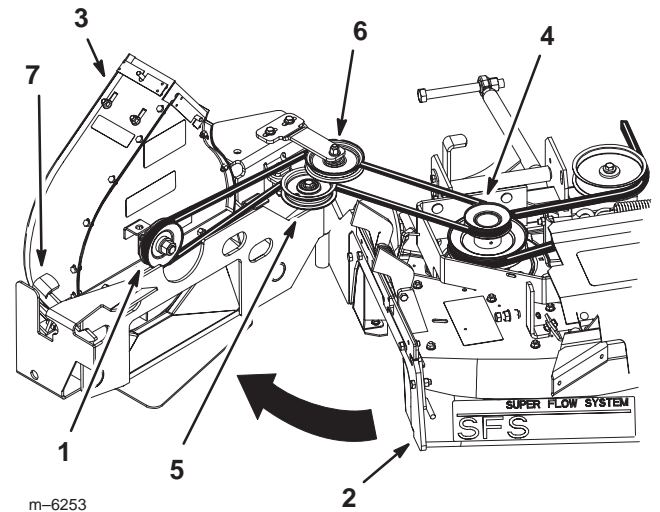

Figure 13

- | | |
|--|--|
| 1. Blower pulley | 5. Spring loaded idler pulley (belt back side touching pulley) |
| 2. Mower | 6. Fixed idler pulley |
| 3. Blower assembly | 7. Front latch (colored red) |
| 4. Top pulley of mower pulley assembly | |

11. Close the blower assembly and ensure the blower front latch engages onto the front peg (Fig. 14).

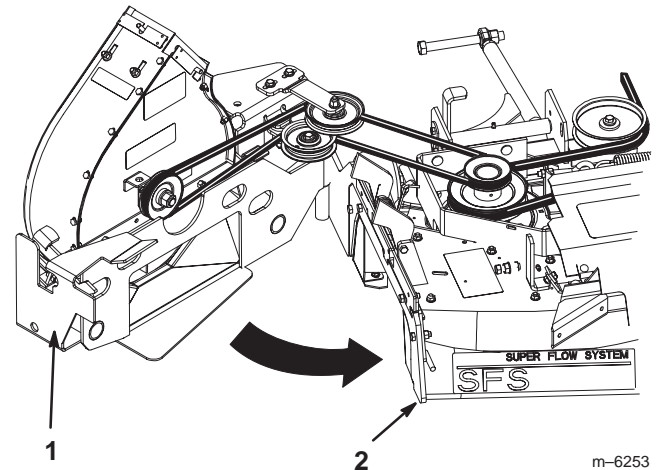

Figure 14

- | | |
|-----------------------------|--------------|
| 1. Blower front latch (Red) | 2. Front peg |
|-----------------------------|--------------|

12. Adjust the bagger belt tension. Refer to Adjusting the Bagger Belt Tension on page 20.
13. Install the belt cover over the pulley assembly and secure the 3 cover latches into the blower (Fig. 16).

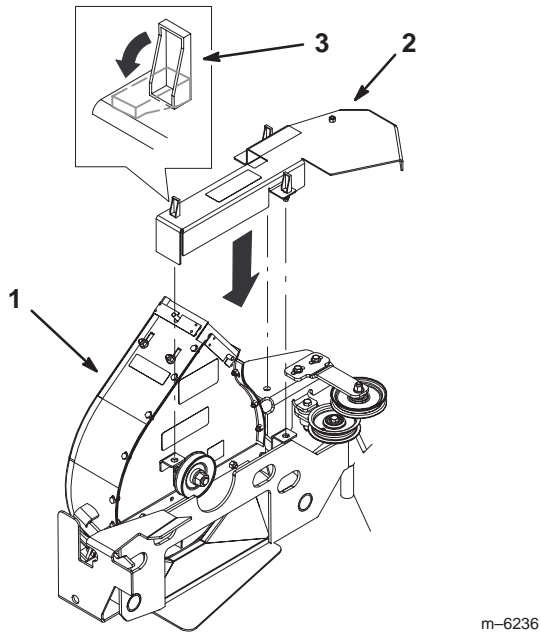

Figure 15

- | | |
|----------------------|----------|
| 1. Blower assembly | 3. Latch |
| 2. Blower belt cover | |

14. For 44 inch (112 cm) mowers, install the new belt cover over the pulley assembly and secure the latch (Fig. 16).

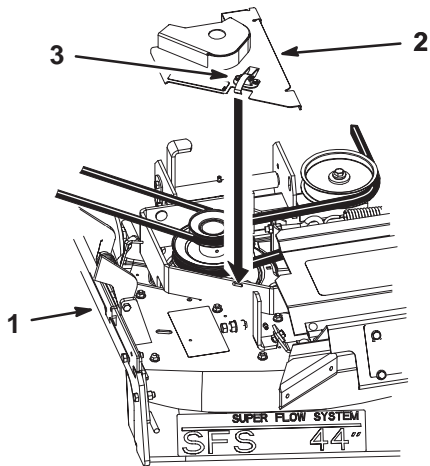

Figure 16

- | | |
|--------------------------------------|----------|
| 1. Mower | 3. Latch |
| 2. 44 inch (112 cm) mower belt cover | |

Step

4

Parts needed for this step:

- 1 Hood assembly
- 2 Bags
- 2 Clevis pins
- 2 Hairpin cotter pins

Installing the Hood Assembly and Bags



Warning



Components around engine will be hot if the machine has been running. Touching hot components can cause burns.

- Do not touch engine components when hot.
- Allow engine to cool before performing maintenance.

1. Install the hood assembly into the bagger bracket (Fig. 17).

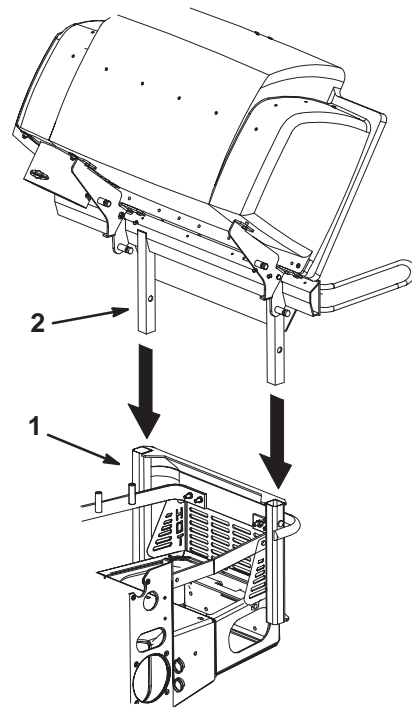

m-6806

Figure 17

1. Bagger bracket
2. Hood assembly

2. Install clevis pins and hairpin cotters into the bagger bracket and hood assembly (Fig. 18).

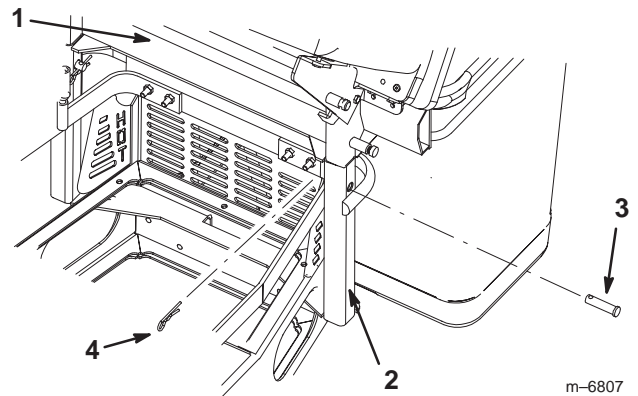

m-6807

Figure 18

1. Hood assembly
2. Bagger bracket
3. Clevis pin
4. Hairpin cotter

3. Install the bag tab into the notch in the hood assembly (Fig. 19). Do this for both bags.

Note: The bag will rest on the bagger frame (Fig. 19).

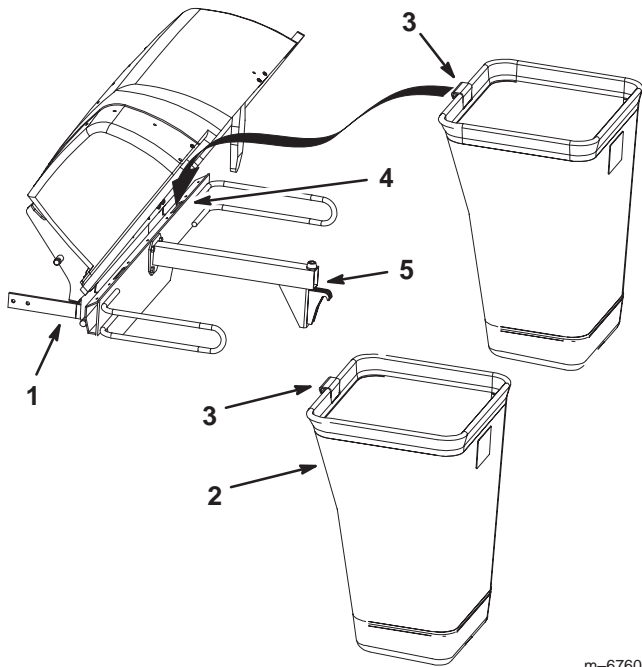

Figure 19

- | | |
|------------------|-----------------|
| 1. Hood assembly | 4. Notch |
| 2. Bag | 5. Bagger frame |
| 3. Bag tab | |

m-6760

4. Lower the bagger hood over the bags.

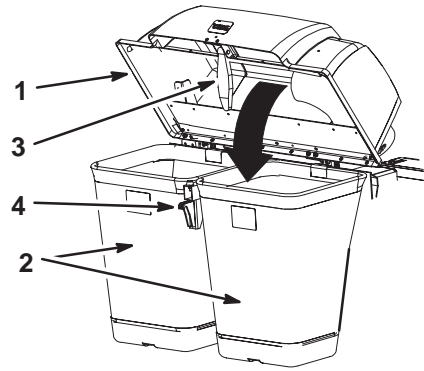

Figure 20

- | | |
|---------|-----------------|
| 1. Hood | 3. Bagger latch |
| 2. Bags | 4. Latch hook |

m-6761

5. Position the bagger latch under the latch hook (Figures 20 and 21).
6. Push down on bagger latch until it locks into place (Fig. 21).

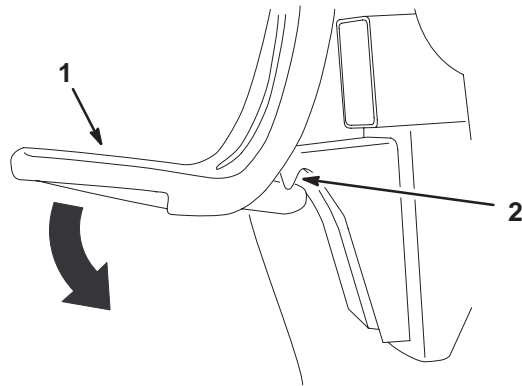

Figure 21

- | | |
|-----------------|---------------|
| 1. Bagger latch | 2. Latch hook |
|-----------------|---------------|

m-6264

Step 5

Parts needed for this step:

- 1 Bagger tube
- 1 Clamp
- 2 Knobs
- 1 Blower adapter

Installing the Bagger Tube

Note: To ease assembly of the bagger tube to the blower adapter, apply soapy water to both the bagger tube and the adapter.

1. Install one end of the tube, 4 to 4-1/2 inches (102 to 114 mm) onto the blower adapter and secure it with a clamp (Fig. 22).

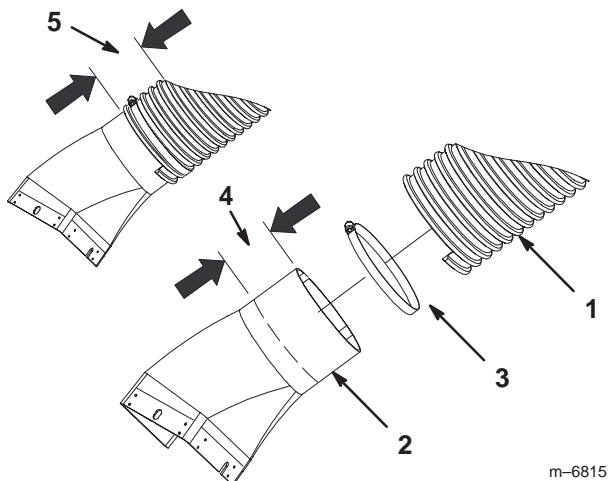
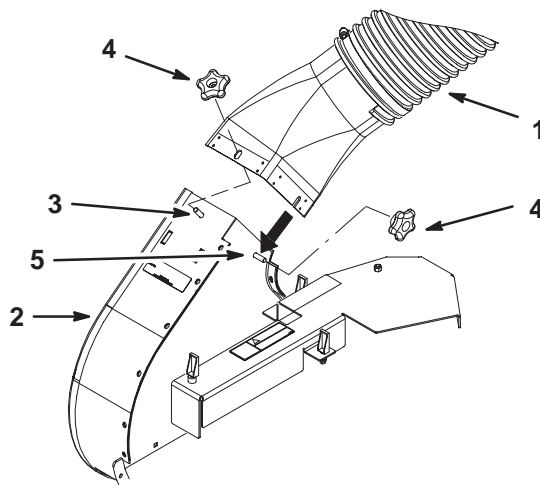

Figure 22

- | | |
|--------------------------------------|--|
| 1. Tube | 5. Tube installed onto the adapter 4 to 4-1/2 inches (102 to 114 mm) |
| 2. Blower adapter | |
| 3. Clamp | |
| 4. 4 to 4-1/2 inches (102 to 114 mm) | |

2. Place the blower adapter over the top blower stud and slide it into the side stud (Fig. 23).
3. Install the knobs onto the top and side stud (Fig. 23). This will secure the lower tube end to the blower assembly.



m-6252

Figure 23

- | | |
|--------------------|---------------------|
| 1. Tube | 4. Knob |
| 2. Blower assembly | 5. Side blower stud |
| 3. Top blower stud | |

Note: There are nubs on the inside of the bagger hood that hold the upper end of the bagger tube (Fig. 24).

4. Place the upper tube into the bagger hood (Fig. 24).
5. Move the upper tube back and forth, until at least two ribs engage into the nubs inside the bagger hood (Fig. 24).

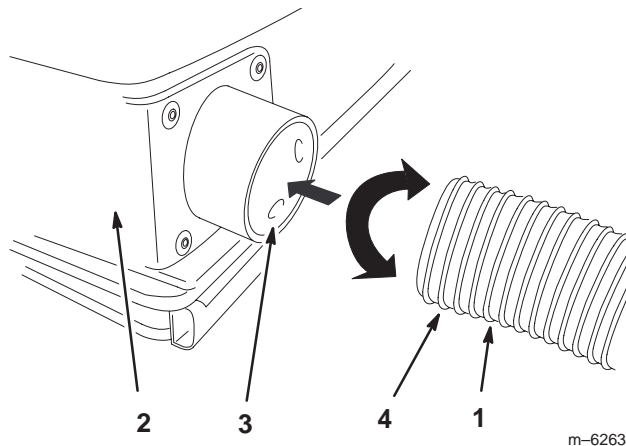

m-6263

Figure 24

- | | |
|----------------|---------|
| 1. Tube | 3. Nubs |
| 2. Bagger hood | 4. Ribs |

Operation

Note: Determine the left and right sides of the machine from the normal operating position.

Important Set the parking brake when leaving the machine unattended, even if just for a few minutes.

Warning

To avoid personal injury, follow these procedures:

- Become familiar with all operating and safety instructions in the operator's manual for your mower before using this attachment.
- Never remove the bagger or bagger tubes while the engine is running.
- Always shut the engine off and wait for all moving parts to stop before clearing an obstruction from the bagging system.
- Never do maintenance or repairs while the engine is running.
- Set the parking brake.

Warning

Without the grass deflector, bagger tubes or complete bagger assembly mounted in place, you and others are exposed to blade contact and thrown debris. Contact with the rotating mower blade(s) and thrown debris will cause injury or death.

- Always install the grass deflector when removing the bagger and changing to side discharge mode.
- If the grass deflector is ever damaged, replace it immediately. The grass deflector routes material down toward the turf.
- Never put your hands or feet under the mower.
- Never try to clear the discharge area or mower blades unless you move the power take off (PTO) to *off* and rotate the ignition key to *off*. Also remove the key and pull the wire off of the spark plug(s).
- Turn off the engine before unclogging the discharge chute.

Caution

Children or bystanders may be injured if they move or attempt to operate the machine while it is unattended.

Always remove the ignition key, set the parking brake and chock or block tires when leaving the machine unattended, even if just for a few minutes.

Emptying the Grass Bags

Grass bags are heavy when full. **Be careful when lifting or handling a grass bag that is full.**

1. Disengage the PTO, set the parking brake, and chock or block the tires if on a slope.
2. Unlatch the bagger latch (Fig. 21).
3. Open the bagger hood.
4. Compress the debris into the bags. With both hands, lift up on the bag and unhook it from the bagger bracket.
5. Grab the handle on the bottom of the bag and tip it over to empty the bag (Fig. 25).

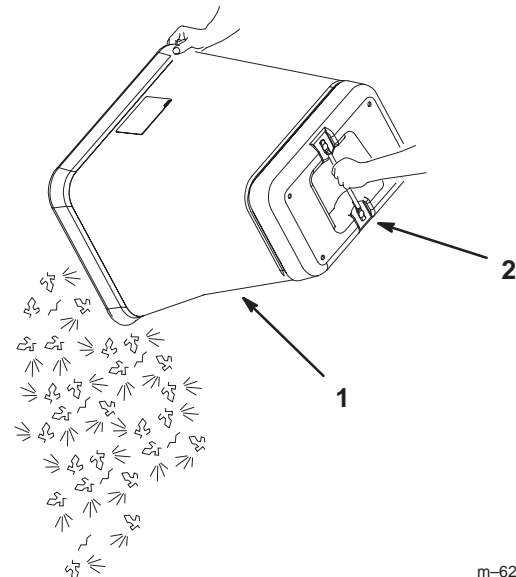

Figure 25

1. Bag
2. Bottom handle

6. Repeat for the other bag.
7. Install the bag tab into the notch in the bagger support frame (Fig. 19). Do this for both bags.
8. Lower the bagger hood over the bags (Fig. 20).
9. Latch the bagger hood (Fig. 21).

Clearing Obstructions From the Bagger System



Danger



When the bagger is in operation, the blower can be rotating and cut off or injure hands.

- Before adjusting, cleaning, repairing and inspecting the blower, and before unclogging the chute, *turn off the engine and wait for all moving parts to stop. Remove the key.*
- Use a stick, *not your hands*, to remove an obstruction from the blower and tube.
- Keep face, hands, feet, and any other part of your body or clothing away from concealed, moving, or rotating parts.

1. Disengage the PTO and set the parking brake.
2. Turn off the engine, remove the key, and wait for all moving parts to stop before leaving the operating position.
3. Empty the bags.
4. Remove the knobs and then the tube from the blower assembly (Fig. 23).
5. Remove the tube from the bagger hood (Fig. 24).
6. Using a stick or similar object, **not your hands**, to remove and clear the obstruction from the tube assembly.

Note: In most cases, the debris can be shaken out of the tube.

7. If the blower assembly is plugged, unlatch the bagger blower assembly and swing it open (Fig. 13).
8. Using a stick or similar object, **not your hands**, to remove and clear the obstruction from the blower assembly.
9. After you remove the obstruction, install the complete bagger system and resume operation.

Removing the Bagger



Warning



Components around engine will be hot if the machine has been running. Touching hot components can cause burns.

- Do not touch engine components when hot.
- Allow engine to cool before removing the bagger.

1. Disengage the PTO, set the parking brake, and chock or block the drive wheels.
2. Turn off the engine, remove the key, and wait for all moving parts to stop before leaving the operating position.
3. Remove the knobs and then the tube from the blower assembly (Fig. 23).
4. Remove the tube from the bagger hood (Fig. 24).
5. Unlatch the belt cover over the mower pulley assembly (Fig. 16).
6. Open the blower assembly to release belt tension and remove the bagger belt from the mower (Fig. 13).
7. Remove the blower assembly from the the mounting plate (Fig. 10).
8. If you are changing to side discharge mode, **ensure the grass deflector is installed** and can be lowered into working position.

Using the Grass Deflector

Note: Make sure the grass deflector is installed when the bagger and tubes are removed.



Warning



Without the grass deflector, bagger tubes or complete bagger assembly mounted in place, you and others are exposed to blade contact and thrown debris. Contact with the rotating mower blade(s) and thrown debris will cause injury or death.

- Always install the grass deflector when removing the bagger and changing to side discharge mode.
- If the grass deflector is ever damaged, replace it immediately. The grass deflector routes material down toward the turf.
- Never put your hands or feet under the mower.
- Never try to clear the discharge area or mower blades unless you move the power take off (PTO) to *off* and rotate the ignition key to *off*. Also remove the key and pull the wire off of the spark plug(s).

1. If the bagger is to be used for a long period of time, leave the grass deflector off the machine. Install the grass deflector when changing to side discharge mode.
2. If the bagger is to be used for a short period of time, leave the grass deflector on the machine. The grass deflector will rest against the belt cover.

Operating and Bagging Tips

Machine Size

Remember that the machine is longer and wider with this attachment installed. By turning too sharply in confined places you may damage the attachment or other property.

Trimming

Always trim with the left side of the mower. Do not trim with the right side of the mower because you could damage the blower assembly and bagging tube.

Cutting Height

For optimum bagging performance, set the deck height-of-cut to remove no more than 2 to 3 inches (51 to 76 mm) or 1/3 of the grass height, whichever is less. Cutting off more than this will reduce the capacity of the vacuum system.

Cutting Frequency

Cut the grass often, especially when it grows rapidly. You will have to cut your grass twice if it gets excessively long. Refer to Bagging Long Grass on page 18.

Cutting Technique

For best lawn appearance, be sure to slightly overlap the mower into the previously cut area. This helps reduce the load on the engine and reduces the chance of plugging the blower assembly and tube.

Bagging Speed

The bagging system may plug if you drive too fast and the engine speed gets too slow. On hills it may be necessary to slow the machine's ground speed. Mow down hill whenever possible.

Bagging Long Grass

Excessively long grass is heavy and may not be propelled completely into the bagger. If this happens, the tube and blower assembly may plug.

Bagging Wet Grass

If possible, always try to cut grass when it is dry. Wet grass can cause plugging.

Reducing Plugging

To avoid plugging the bagging system, reduce ground speed and mow the grass at a high height-of-cut, then lower the mower to your normal cutting height and repeat the bagging process.

Signs of Plugging



As you are bagging, a small amount of grass clippings normally blow out the front of the mower. An excessive amount of clipping blow-out indicates that the bagger is full or the tube is plugged.

Bagging Blades

In most mowing conditions, improved bagging performance can be achieved by using bagging blades (high lift). Contact an Authorized Service Dealer for the proper blades for different mowing conditions.

Curb Climbing and Loading

Always lift the deck to the highest position when loading the machine on trailers or ascending/descending a curb. Leaving the mower in a lower position can cause damage to mower baffles while loading and going over a curb. If a curb is higher than 6 inches (152 mm), cross it at a sharp angle with the deck fully raised. **Use extreme caution when loading onto a trailer.**

Caution

As the bagger fills, extra weight is added to the back of the machine. If you stop and start suddenly on hills, you may lose steering control or the machine may tip.

- **Do not start or stop suddenly when going uphill or downhill. Avoid uphill starts.**
- **If you do stop the machine when going uphill, disengage the PTO. Then back down the hill using a slow speed.**
- **Do not change speeds or stop on slopes.**

Maintenance

Important If the machine is on a slope, set the parking brake and chock or block the wheels to prevent the machine from slowly rolling.

Recommended Maintenance Schedule

Maintenance Service Interval	Maintenance Procedure
Each Use	<ul style="list-style-type: none">• Hood screen—clean
First 8 Hours	<ul style="list-style-type: none">• Bagger—inspect• Bagger belt—check and adjust
8 Hours	<ul style="list-style-type: none">• Bagger—clean
25 Hours	<ul style="list-style-type: none">• Bagger belt—check and adjust• Bagger idler arm—grease
40 Hours	<ul style="list-style-type: none">• Blower liner—inspect
100 Hours	<ul style="list-style-type: none">• Bagger—inspect
Storage Service	<ul style="list-style-type: none">• Belt—check for wear/cracks• Bagger—inspect• Bagger—clean

Note: Determine the left and right side of the machine from the normal operating position.

Cleaning the Hood Screen

The screen needs to be cleaned before each use. In wet grass it will need to be cleaned more often.

1. Disengage the PTO, set the parking brake, and chock or block the drive wheels.
2. Turn off the engine, remove the key, and wait for all moving parts to stop before leaving the operating position.
3. Open the bagger and hold the bagger hood open.
4. Clean the debris from the screen.
5. Close the bagger hood.

Cleaning the Bagger

The screen needs to be cleaned before each use. In wet grass it will need to be cleaned more often.

1. Wash the inside and outside of the bagger hood, tube, and the underside of the mower. Use a mild automotive detergent to remove dirt.
2. Make sure you remove matted grass from all parts.
3. After washing all parts, let them dry thoroughly.

Note: With all parts installed, start and run the machine for a minute to assist in drying.

Checking and Adjusting the Bagger Belt Tension

Check the bagger belt tension every 25 hours.

Note: When checking the belt tension, the spring length needs to be **between 4 inches and 4-3/4 inches** (102 and 121 mm) (Fig. 26).

Important Adjust the bagger belt if the spring length is 4 inches (102 mm) or less.

1. Disengage the PTO and set the parking brake.
2. Turn off the engine, remove the key, and wait for all moving parts to stop before leaving the operating position.
3. Close the blower assembly and measure between the spring coil ends. See Figure 26 for measuring the spring length and eye hook orientation.

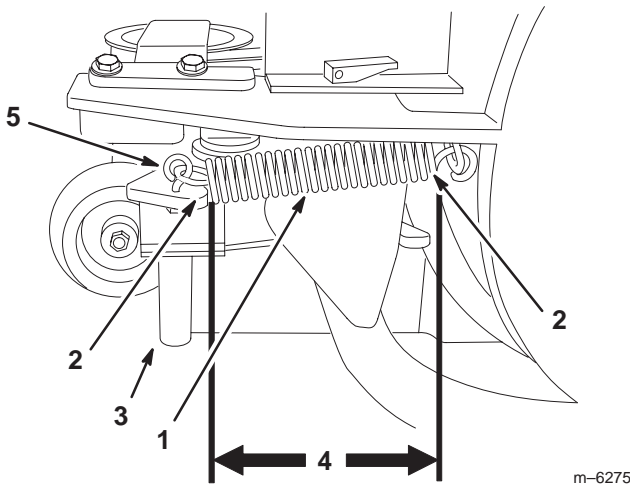

Figure 26

- | | |
|------------------------|--|
| 1. Spring | 4. Distance between spring coil ends, 4 to 4-3/4 inches (102 mm to 121 mm) |
| 2. End of spring coils | |
| 3. Blower assembly peg | |
| 5. Eye bolt | |

Note: When adjustment is needed, set the spring length to **4-3/4 inches (121 mm) +/- 1/4 inch (6 mm)** (Fig. 26).

4. If adjustment is needed, open the blower assembly to remove tension from the bagger belt (Fig. 13).
5. Loosen the two bolts that hold the fixed idler to the blower assembly (Fig. 27).
6. Adjust the fixed idler towards the rear to **lengthen the spring and increase belt tension** (Fig. 27).
7. Adjust the fixed idler towards the front to **shorten the spring and decrease belt tension** (Fig. 27).
8. Tighten the two bolts that hold the fixed idler to the blower assembly (Fig. 27).

9. Close the blower assembly and measure the spring length again. Adjust the fixed idler until the correct spring length is achieved.

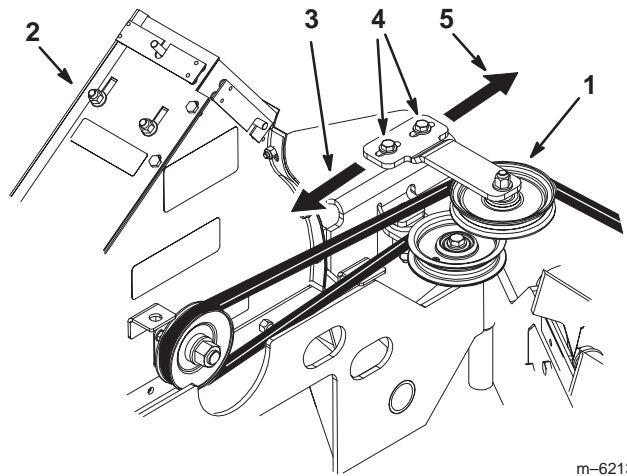

Figure 27

- | | |
|--|--|
| 1. Fixed idler | 4. Bolts |
| 2. Blower assembly | 5. Adjust idler to the rear to lengthen the spring |
| 3. Adjust idler to the front to shorten the spring | |

Checking and Adjusting the Blower Latch

Adjust the blower latch when it does not engage the front peg correctly.

1. There must **not** be a gap between the mounting plate the the blower assembly (Fig. 28). If there is a gap, proceed to step 3 and shorten the latch.

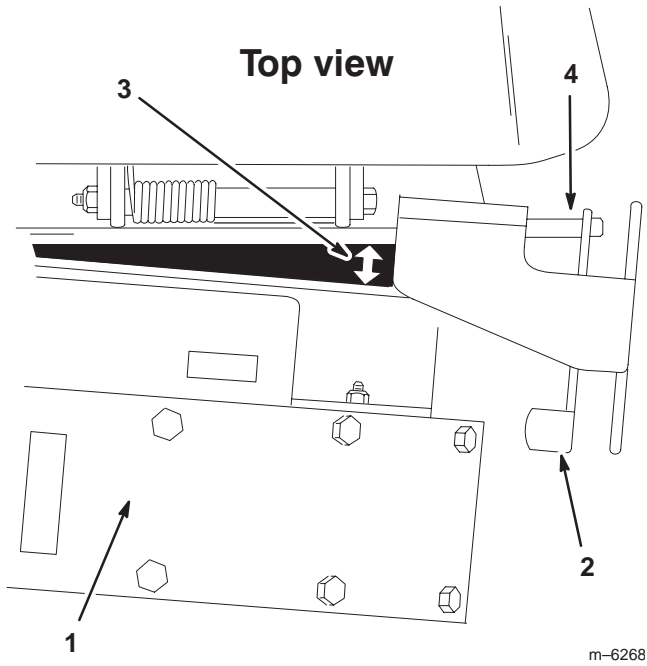

Figure 28

- | | |
|-----------------------------|--------------|
| 1. Blower assembly | 3. Gap shown |
| 2. Blower front latch (Red) | 4. Front peg |

2. The blower latch must engage over the front peg (Fig. 29). If it does not, proceed to step 3 and lengthen the latch.

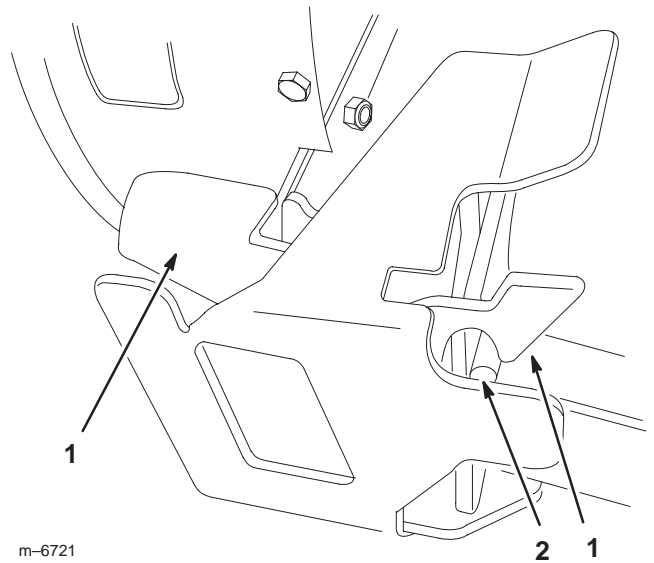

Figure 29

- | | |
|-----------------------------|--------------|
| 1. Blower front latch (Red) | 2. Front peg |
|-----------------------------|--------------|

3. To adjust the blower latch, loosen the jam nut. (Fig. 30).
4. To lengthen the latch turn the hex nut counterclockwise to loosen the nut. (Fig. 30).
5. To shorten the latch turn the hex nut clockwise to tighten the nut. (Fig. 30).
6. When the desired latch length is correct, tighten both nuts. (Fig. 30).

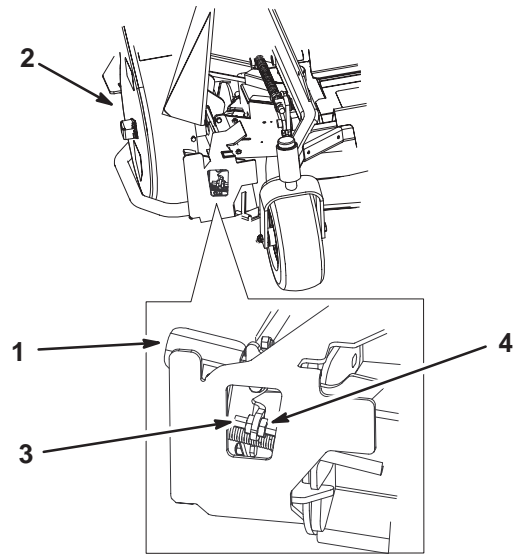

Figure 30

- | | |
|-----------------------------|------------|
| 1. Blower front latch (red) | 3. Hex nut |
| 2. Blower | 4. Jam nut |

Replacing the Blower Belt

Check the bagger belt for wear and cracks after the first 8 hours and then every 25 hours.

1. Disengage the PTO, set the parking brake, and chock or block the drive wheels.
2. Turn off the engine, remove the key, and wait for all moving parts to stop before leaving the operating position.
3. Push down on the front latch and open the blower assembly (Fig. 13). This will automatically remove the tension from the blower belt.
4. **For 52 inch mowers only**, remove the bagger belt between the top mower pulley and the mower belt cover (Fig. 12).
5. **For 44 inch mowers only**, remove the mower belt cover (Fig. 16).
6. Remove the blower belt cover (Fig. 31).
7. Remove the bagger belt from the top pulley of the mower pulley assembly (Fig. 32).

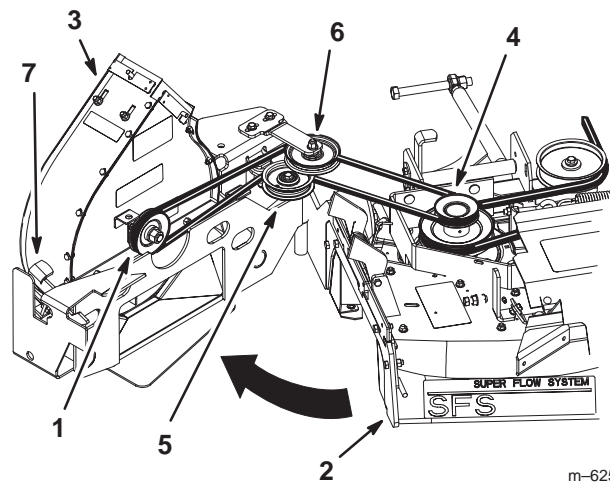

m-6253

Figure 32

- | | |
|--|-------------------------------|
| 1. Blower pulley | 5. Spring loaded idler pulley |
| 2. Mower | 6. Fixed idler pulley |
| 3. Blower assembly | 7. Front latch |
| 4. Top pulley of mower pulley assembly | |

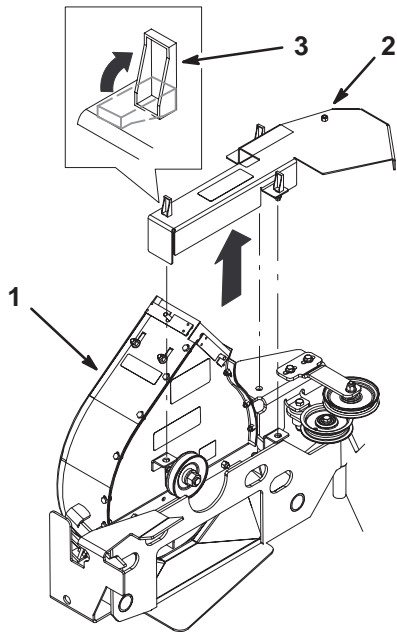

m-6236

Figure 31

- | | |
|----------------------|----------|
| 1. Blower assembly | 3. Latch |
| 2. Blower belt cover | |

8. Remove the bagger belt from the spring-loaded idler pulley and the fixed idler pulley (Fig. 32).
9. Remove the bagger belt from the blower assembly pulley (Fig. 32).
10. Install the new bagger belt. Refer to Installing the Bagger Belt on page 10.

Greasing the Idler Arm

Grease the bagger belt idler arm every 25 hours (Fig. 33).

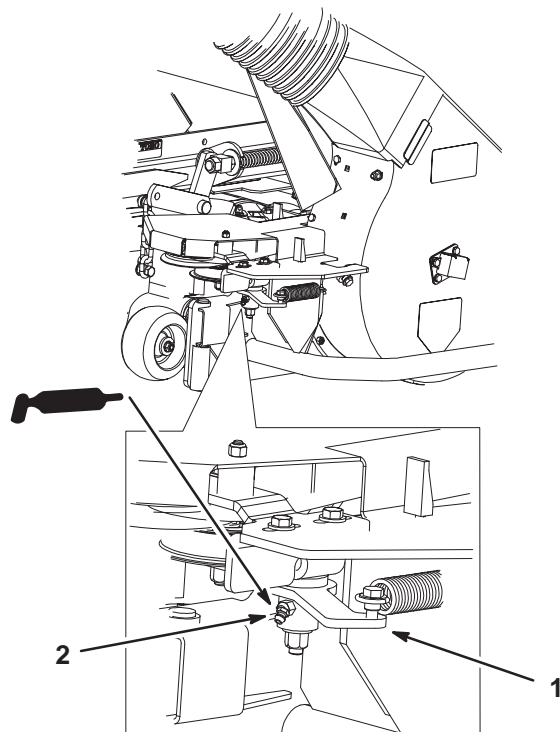

m-6251

Figure 33

- | | |
|---------------------|----------------|
| 1. Bagger idler arm | 2. Grease zerk |
|---------------------|----------------|

Checking the Blower Liner

Check the blower liner inside the blower every 40 hours and more often in extreme mowing and bagging conditions.

1. Remove the blower adapter and tube from the blower (Fig. 23).
2. Check the liner for any excessive wear. **Do not** use your hands to check the liner or remove debris.
3. Replace the liner if any excessive wear is noticed.

Replacing the Blower Liner

1. Disengage the PTO and set the parking brake.
2. Turn off the engine, remove the key, and wait for all moving parts to stop before leaving the operating position.
3. Remove the five bolts that hold the blower liner to the blower (Figures 34 and 35).
4. Pull the liner out of the blower (Fig. 34).
5. Slide the new liner around the blower impeller.
6. Install 3 bolts into the rear of the blower and the liner (Fig. 34).

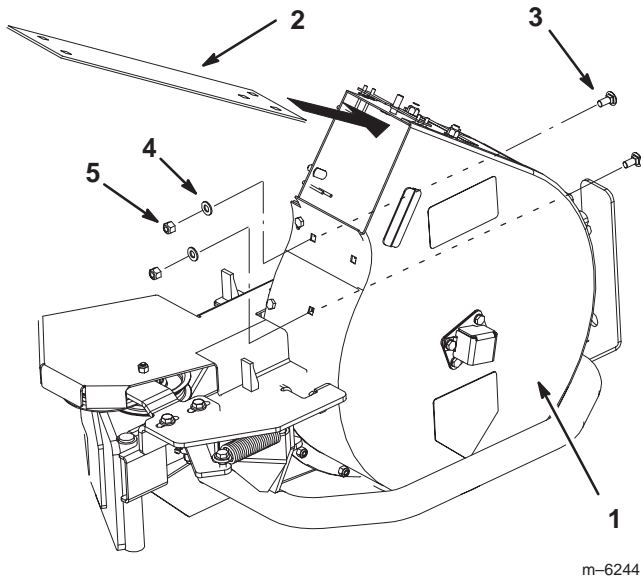

Figure 34

- | | |
|-----------|-----------|
| 1. Blower | 4. Washer |
| 2. Liner | 5. Nut |
| 3. Bolt | |

7. Loosely install 2 bolts into the liner and the blower (Fig. 35).

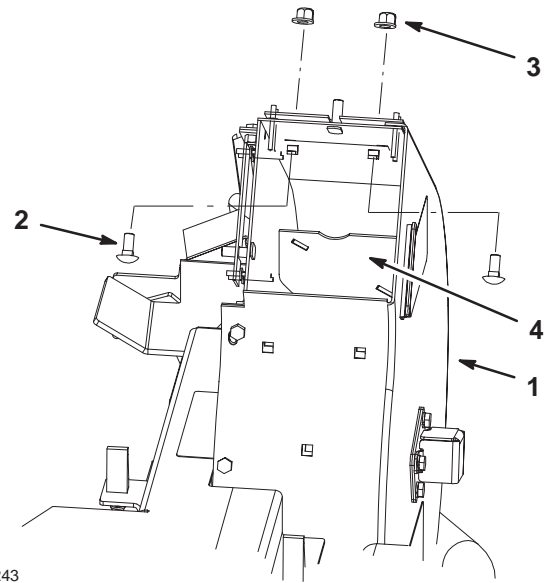

Figure 35

- | | |
|-----------|-------------|
| 1. Blower | 3. Nut |
| 2. Bolt | 4. Impeller |

8. Push the top 2 bolts down, toward the front of blower, until the blower liner conforms to the inside of the blower (Fig. 36). This will provide clearance between the impeller and the liner.
9. Rotate the blower pulley to verify that the blower fan does not hit the liner (Fig. 36). Adjust the liner if necessary.
10. Tighten the 2 top bolts in the liner and the blower (Fig. 36).

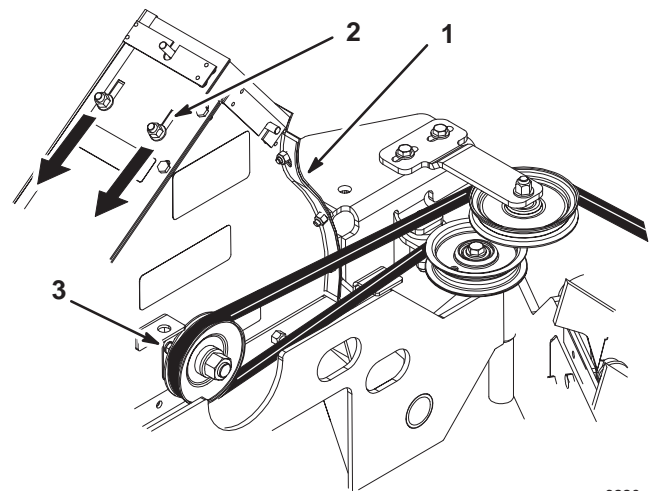

Figure 36

- | | |
|-----------|---------------------|
| 1. Blower | 2. Top bolt and nut |
|-----------|---------------------|

Inspecting the Bagger

Inspect the bagger attachment after the first 8 hours of operation and 100 hours thereafter.

1. Disengage the PTO, set the parking brake, and chock or block the drive wheels.
2. Turn off the engine, remove the key, and wait for all moving parts to stop before leaving the operating position.
3. Check the tube, blower assembly, and the bagger hood. Replace these parts if they are cracked or broken.
4. Check the bags, bagger frame, and screen. Replace any parts that are cracked, worn or broken.
5. Tighten all nuts, bolts and screws.

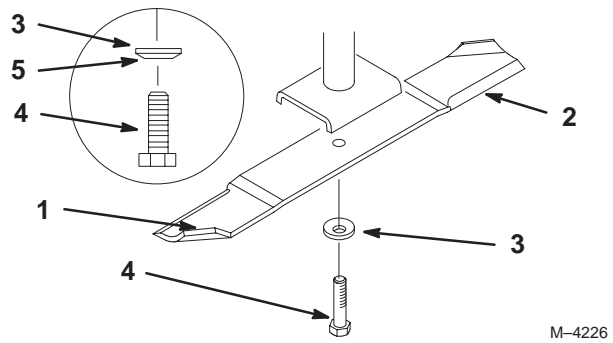

Figure 37

- | | |
|-----------------------|---------------------------|
| 1. Sail Area of Blade | 4. Blade Bolt |
| 2. Blade | 5. Cone Towards Bolt Head |
| 3. Spring Disk | |

Inspecting the Mower Blades and Baffles

1. Inspect the mower blades and baffles regularly and whenever a blade strikes a foreign object.
2. If blades or baffles are badly worn or damaged, install new blades or baffles. Refer to your mower operator's manual for complete blade maintenance.

Installing Mower Blades

Note: In most mowing conditions, improved bagging performance can be achieved by using bagging blades (high lift). Contact an Authorized Service Dealer for the proper blades for different mowing conditions.

1. Install the blade onto the spindle shaft (Fig. 37).

Important The curved part of the blade must be pointing upward toward the inside of the mower to ensure proper cutting.

2. Install the spring disk and blade bolt (Fig. 37). **Torque the blade bolt to 85–110 ft-lb (115–150 N•m).**
3. Rotate the blades to ensure there is clearance between the blade tips and the baffles.
4. If contact is made, **do not use the mower.** Check and make sure the baffles are installed properly.

Important Do not use the mower if blades contact the baffles.

Installing the Grass Deflector

The grass deflector spring will have either an **L** end or a straight end (Fig. 38).

Note: Make sure the grass deflector is installed when the bagger and tubes are removed.

Warning

An uncovered discharge opening could allow the lawn mower to throw objects in the operator's or bystander's direction and result in serious injury. Also, contact with the blade could occur.

Never operate the lawn mower unless you install a cover plate, a mulch plate, grass deflector or a grass chute and catcher.

1. Place spacer and spring onto grass deflector. Place the **L** or the straight end of spring behind deck edge.

Note: Make sure the **L** or the straight end of spring is installed behind deck edge before installing the bolt as shown in figure 38.

2. Install bolt and nut. Place **J** hook end of spring around grass deflector (Fig. 38).

Important The grass deflector must be lowered down into position. Lift the deflector up to test that it lowers into the full down position.

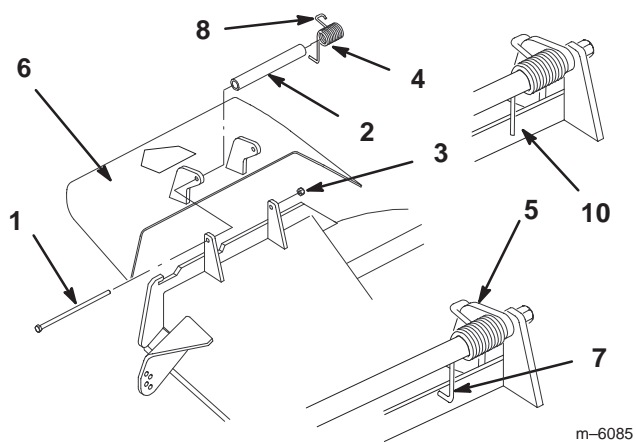

m-6085

Figure 38

- | | |
|--|---|
| <ul style="list-style-type: none"> 1. Bolt 2. Spacer 3. Locknut 4. Spring 5. Spring installed 6. Grass Deflector | <ul style="list-style-type: none"> 7. L end of spring, place behind mounting bracket before installing bolt 8. J hook end of spring 9. Mounting bracket 10. Straight end—possible style of spring |
|--|---|

Storage

1. Clean the bagger attachment. Refer to Cleaning the Bagger on page 19.
2. Inspect the bagger attachment for damage. Refer to Inspecting the Bagger on page 19.
3. Make sure the bags are empty and thoroughly dry.
4. Check the belt for wear or cracks.
5. Store the machine in a clean, dry place, out of direct sunlight. If you must store the machine outside, cover it with a weatherproof cover. This protects the plastic parts and extends the life of the machine.

Troubleshooting

Problem	Possible Causes	Corrective Action
Abnormal vibration.	<ol style="list-style-type: none"> 1. Cutting blade(s) bent or unbalanced. 2. Blade mounting bolt is loose. 3. Loose blower pulley or pulley assembly. 4. Blower belt is worn or damaged. 5. Blower impeller is out of balance. 6. Blower impeller is bent. 	<ol style="list-style-type: none"> 1. Install new cutting blade(s). 2. Tighten blade mounting bolt. 3. Tighten the appropriate pulley. 4. Replace the blower belt. 5. Contact Authorized Service Dealer. 6. Do not use machine. Replace bent impeller.
Reduced bagging performance.	<ol style="list-style-type: none"> 1. Low engine speed. 2. Plugged screen. 3. Loose blower belt. 4. A plugged tube. 5. Full bags. 	<ol style="list-style-type: none"> 1. Always operate the bagger at full throttle. 2. Remove debris, leaves or grass clippings from the screen. 3. Adjust the blower belt tension. 4. Locate and remove plugged debris. 5. Empty bags.
Blower and tube plug too frequently.	<ol style="list-style-type: none"> 1. Bags are too full. 2. Low engine speed. 3. Grass is too wet. 4. Grass is too long. 5. Plugged screen. 6. Ground speed is too fast. 7. Worn blower belt. 	<ol style="list-style-type: none"> 1. Dump more frequently. 2. Always operate the bagger at full throttle. 3. Cut grass when dry. 4. Cut no more than 2 to 3 inches (51 to 76 mm) or 1/3 of the grass height, whichever is less. 5. Remove debris, leaves or grass clippings from the screen. 6. Drive slower at full throttle. 7. Replace belt.
Debris blowout.	<ol style="list-style-type: none"> 1. Bags are too full. 2. Ground speed is too fast. 3. Mower is not leveled. 	<ol style="list-style-type: none"> 1. Dump more frequently. 2. Drive slower at full throttle. 3. See the mower operator's manual for leveling the mower.
Blower impeller does not spin freely.	<ol style="list-style-type: none"> 1. Plugged blower. 2. Impeller not aligned. 	<ol style="list-style-type: none"> 1. Remove debris, leaves or grass clippings from the blower impeller. 2. Contact Authorized Service Dealer.

