



Count on it.

Operator's Manual

TimeCutter[®] ZX440 Riding Mower

Model No. 74406—Serial No. 250000001 and Up

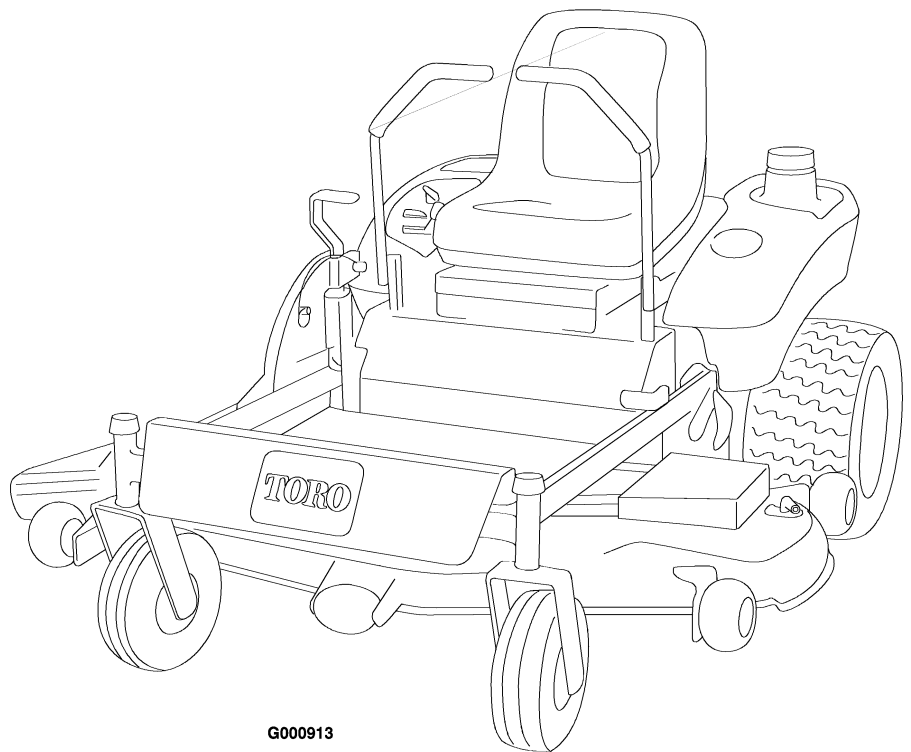

G000913

This spark ignition system complies with Canadian ICES-002

Contents

Introduction.....	2
Safety.....	4
Safe Operation Practices for Ride-on (riding) Rotary Lawnmower Machines.....	4
Safe Operating Practices.....	4
Toro Riding Mower Safety.....	5
Sound Pressure.....	6
Sound Power.....	6
Vibration.....	6
Slope Chart.....	7
Safety and Instructional Decals.....	8
Product Overview.....	11
Controls.....	11
Operation.....	12
Think Safety First.....	12
Recommended Gasoline.....	12
Checking the Engine Oil Level.....	13
Using the Parking Brake.....	14
Starting and Stopping the Engine.....	14
Operating the Power Take Off (PTO).....	15
The Safety Interlock System.....	15
Driving Forward or Backward.....	16
Stopping the Machine.....	16
Adjusting the Height of Cut.....	17
Adjusting the Anti-Scalp Rollers.....	17
Positioning the Seat.....	17
Adjusting the Motion Control Levers.....	18
Pushing the Machine by Hand.....	18
Removing the Recycler® Baffle.....	18
Installing the Recycler® Baffle.....	19
Side Discharge.....	19
Operating Tips.....	19
Maintenance.....	21
Recommended Maintenance Schedule(s).....	21
Lubrication.....	21
How to Grease.....	21
Where to Add Grease.....	22

Engine Maintenance.....	22
Servicing the Engine Oil.....	22
Servicing the Air Cleaner.....	24
Cleaning the Cooling System.....	25
Fuel System Maintenance.....	25
Replacing the Fuel Filter.....	25
Draining the Fuel Tank.....	26
Electrical System Maintenance.....	26
Spark Plug.....	26
Servicing the Battery.....	27
Servicing the Fuses.....	29
Drive System Maintenance.....	29
Checking the Tire Pressure.....	29
Mower Maintenance.....	30
Servicing the Cutting Blades.....	30
Leveling the Mower from Side-to-Side.....	32
Adjusting the Front-to-Rear Blade Slope.....	32
Removing the Mower.....	33
Inspecting the Belts.....	34
Replacing the Mower Belt.....	34
Installing the Mower.....	35
Replacing the Grass Deflector.....	35
Cleaning.....	36
Washing the Underside of the Mower.....	36
Storage.....	37
Cleaning and Storage.....	37
Troubleshooting.....	38
Schematics.....	41

Introduction

Read this information carefully to learn how to operate and maintain your product properly and to avoid injury and product damage. You are responsible for operating the product properly and safely.

You may contact Toro directly at www.Toro.com for product and accessory information, help finding a dealer, or to register your product.

Whenever you need service, genuine Toro parts, or additional information, contact an Authorized Service Dealer or Toro Customer Service and have the model and serial numbers of your product ready. Figure 1 identifies the location of the model and serial numbers on the product. Write the numbers in the space provided.

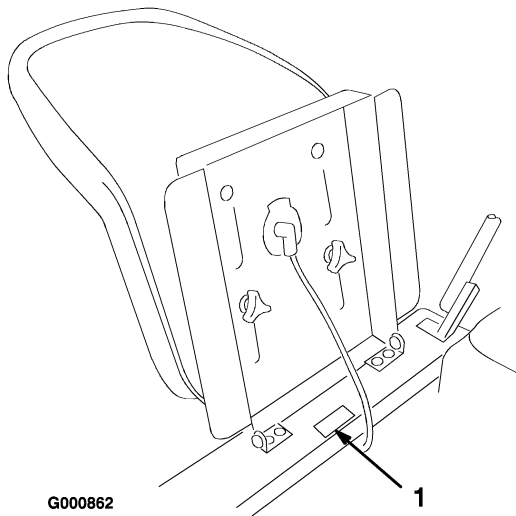

Figure 1

1. Model and serial number plate

Model No. _____
Serial No. _____

This manual identifies potential hazards and has safety messages identified by the safety alert symbol (Figure 2), which signals a hazard that may cause serious injury or death if you do not follow the recommended precautions.



Figure 2

1. Safety alert symbol.

This manual uses two other words to highlight information. **Important** calls attention to special mechanical information and **Note** emphasizes general information worthy of special attention.

Safety

Safe Operation Practices for Ride-on (riding) Rotary Lawnmower Machines

This machine meets or exceeds European Standards in effect at the time of production. However, improper use or maintenance by the operator or owner can result in injury. To reduce the potential for injury, comply with these safety instructions and always pay attention to the safety alert symbol, which means CAUTION, WARNING, or DANGER -“personal safety instruction.” Failure to comply with the instruction may result in personal injury or death.

Safe Operating Practices

The following instructions are from the CEN standard EN 836:1997.

This product is capable of amputating hands and feet and throwing objects. Always follow all safety instructions to avoid serious injury or death.

Training

- Read the instructions carefully. Be familiar with the controls and the proper use of the equipment.
- Never allow children or people unfamiliar with these instructions to use the lawnmower. Local regulations can restrict the age of the operator.
- Never mow while people, especially children, or pets are nearby.
- Keep in mind that the operator or user is responsible for accidents or hazards occurring to other people or their property.
- Do not carry passengers.
- All drivers should seek and obtain professional and practical instruction. Such instruction should emphasize:
 - the need for care and concentration when working with ride-on machines;
 - control of a ride-on machine sliding on a slope will not be regained by the application of the brake. The main reasons for loss of control are:
 - ◇ insufficient wheel grip;

- ◇ being driven too fast;
- ◇ inadequate braking;
- ◇ the type of machine is unsuitable for its task;
- ◇ lack of awareness of the effect of ground conditions, especially slopes;
- ◇ incorrect hitching and load distribution.

Preparation

- While mowing, always wear substantial footwear and long trousers. Do not operate the equipment when barefoot or wearing open sandals.
- Thoroughly inspect the area where the equipment is to be used and remove all objects which may be thrown by the machine.
- Warning-Fuel is highly flammable.
 - Store fuel in containers specifically designed for this purpose.
 - Refuel outdoors only and do not smoke while refuelling.
 - Add fuel before starting the engine. Never remove the cap of the fuel tank or add fuel while the engine is running or when the engine is hot.
 - If fuel is spilled, do not attempt to start the engine but move the machine away from the area of spillage and avoid creating any source of ignition until fuel vapors have dissipated.
 - Replace all fuel tanks and container caps securely.
- Replace faulty silencers.
- Before using, always visually inspect to see that the blades, blade bolts and cutter assembly are not worn or damaged. Replace worn or damaged blades and bolts in sets to preserve balance.
- On multi-bladed machines, take care as rotating one blade can cause other blades to rotate.

Operation

- Be alert, slow down and use caution when making turns. Look behind and to the side before changing directions.

- Do not operate the engine in a confined space where dangerous carbon monoxide fumes can collect.
- Mow only in daylight or in good artificial light.
- Before attempting to start the engine, disengage all blade attachment clutches and shift into neutral.
- Do not use on slopes of more than 12-1/2 degrees.
- Remember there is no such thing as a safe slope. Travel on grass slopes requires particular care. To guard against overturning:
 - do not stop or start suddenly when going up or downhill;
 - use low speeds on slopes and during tight turns;
 - stay alert for humps and hollows and other hidden hazards;
- Use care when pulling loads.
 - Use only approved drawbar hitch points.
 - Limit loads to those you can safely control.
 - Do not turn sharply. Use care when reversing.
- Watch out for traffic when crossing or near roadways.
- Stop the blades rotating before crossing surfaces other than grass.
- When using any attachments, never direct discharge of material toward bystanders nor allow anyone near the machine while in operation.
- Never operate the machine with damaged guards or without safety protective devices in place.
- Do not change the engine governor settings or overspeed the engine. Operating the engine at excessive speed can increase the hazard of personal injury.
- Before leaving the operator's position:
 - disengage the power take-off and lower the attachments;
 - change into neutral and set the parking brake;
 - stop the engine and remove the key.
- Disengage drive to attachments, stop the engine, and disconnect the spark plug wire(s) or remove the ignition key
 - before clearing blockages or unclogging chute;
 - before checking, cleaning or working on the lawnmower;
 - after striking a foreign object. Inspect the lawnmower for damage and make repairs before restarting and operating the equipment;
 - if the machine starts to vibrate abnormally (check immediately).
- Disengage drive to attachments when transporting or not in use.
- Stop the engine and disengage drive to attachment
 - before refuelling;
 - before removing the grass catcher;
 - before making height adjustment unless adjustment can be made from the operator's position.
- Reduce the throttle setting during engine run-out and, if the engine is provided with a shut-off valve, turn the fuel off at the conclusion of mowing.

Maintenance and Storage

- Keep all nuts, bolts and screws tight to be sure the equipment is in safe working condition.
- Never store the equipment with fuel in the tank inside a building where fumes can reach an open flame or spark.
- Allow the engine to cool before storing in any enclosure.
- To reduce the fire hazard, keep the engine, silencer, battery compartment and fuel storage area free of grass, leaves, or excessive grease.
- Check the grass catcher frequently for wear or deterioration.
- Replace worn or damaged parts for safety.
- If the fuel tank has to be drained, this should be done outdoors.
- When machine is to be parked, stored or left unattended, lower the cutting means.

Toro Riding Mower Safety

The following list contains safety information specific to Toro products or other safety

information that you must know that is not included in the CEN standard.

- Engine exhaust contains carbon monoxide, which is an odorless, deadly poison that can kill you. Do not run engine indoors or in an enclosed area.
- Keep hands, feet, hair and loose clothing away from attachment discharge area, underside of mower and any moving parts while engine is running.
- Do not touch equipment or attachment parts which may be hot from operation. Allow to cool before attempting to maintain, adjust, or service.
- Battery acid is poisonous and can cause burns. Avoid contact with skin, eyes and clothing. Protect your face, eyes, and clothing when working with a battery.
- Battery gases can explode. Keep cigarettes, sparks, and flames away from battery.
- Use only genuine Toro replacement parts to ensure that original standards are maintained.
- Use only Toro-approved attachments.

Slope Operation

- Do not mow slopes greater than 12-1/2 degrees.
- Do not mow near drop-offs, ditches, steep banks, or water. Wheels dropping over edges can cause rollovers, which may result in serious injury, death, or drowning.
- Do not mow slopes when grass is wet. Slippery conditions reduce traction and could cause sliding and loss of control.
- Do not make sudden turns or rapid speed changes.
- Use a walk behind mower and/or a hand trimmer near drop-offs, ditches, steep banks, or water.
- Reduce speed and use extreme caution on slopes.
- Remove or mark obstacles such as rocks, tree limbs, etc. from mowing area. Tall grass can hide obstacles.
- Watch for ditches, holes, rocks dips, and rises that change the operating angle, as rough terrain could overturn the machine.

- Avoid sudden starts when mowing uphill because the mower may tip backwards.
- Be aware that loss of traction may occur going downhill. Weight transfer to the front wheels may cause drive wheels to slip and cause loss of braking and steering.
- Always avoid sudden starting or stopping on a slope. If tires lose traction, disengage the blades and proceed slowly off the slope.
- Follow the manufacturer's recommendations for wheel weights or counterweights to improve stability.
- Use extreme care with grass catchers or other attachments. These can change the stability of the machine and cause loss of control.

Sound Pressure

This unit has a maximum sound pressure level at the operator's ear of 87 dBA, based on measurements of identical machines per EN11094 and EN836.

Sound Power

This unit has a guaranteed sound power level of 100 dBA, based on measurements of identical machines per EN11094.

Vibration

This unit does not exceed a hand/arm vibration level of 1.6 m/s², based on measurements of identical machines per EN1033.

This unit does not exceed a whole body vibration level of 1.9 m/s², based on measurements of identical machines per EN1032.

Slope Chart

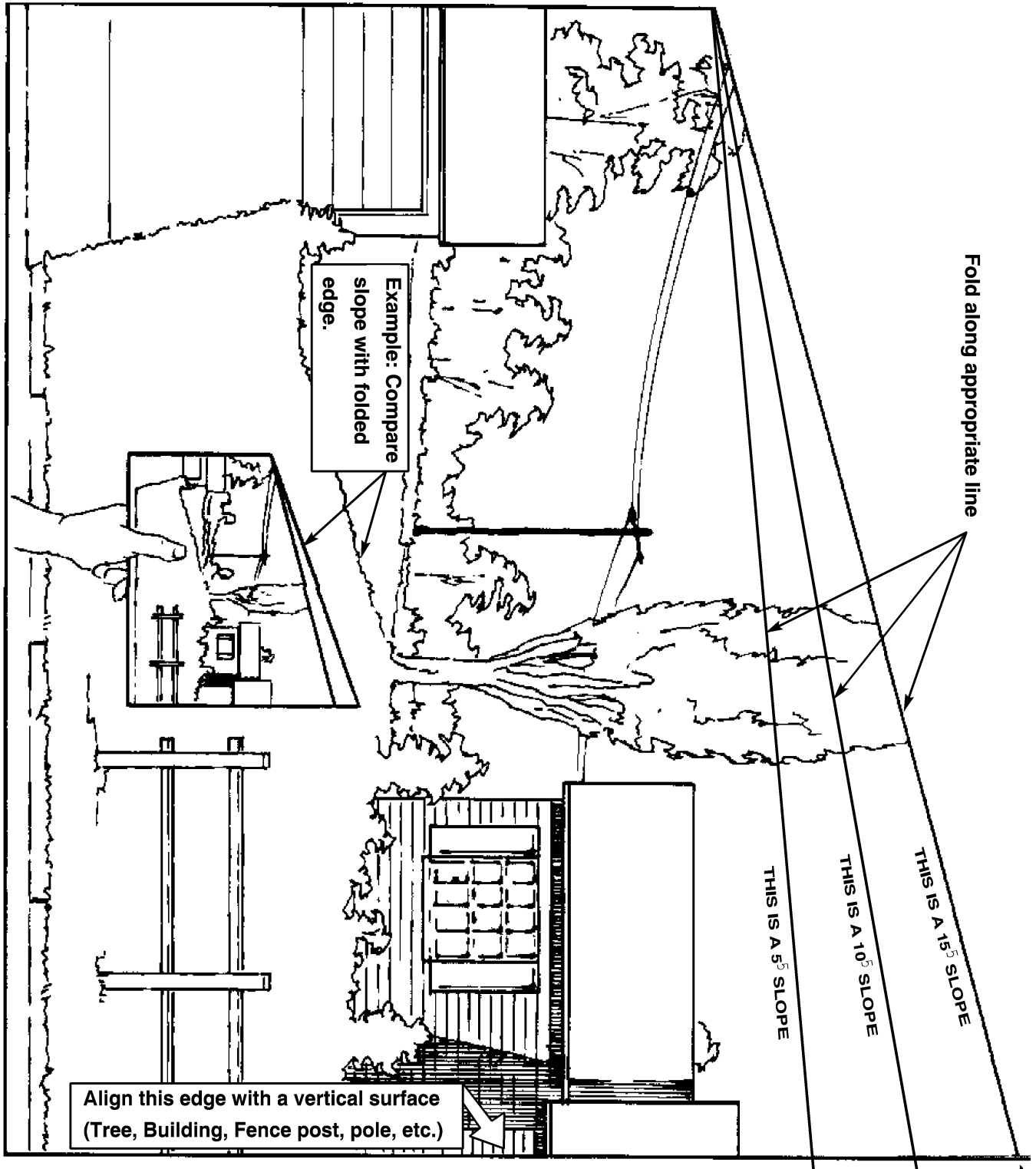

Safety and Instructional Decals



Safety decals and instructions are easily visible to the operator and are located near any area of potential danger. Replace any decal that is damaged or lost.

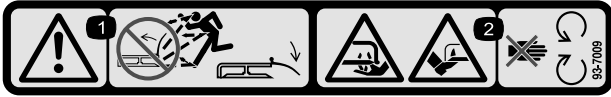

93-7009

1. Warning—don't operate the mower with the deflector up or removed; keep the deflector in place.
2. Cutting/dismemberment hazard of hand or foot, mower blade—stay away from moving parts.

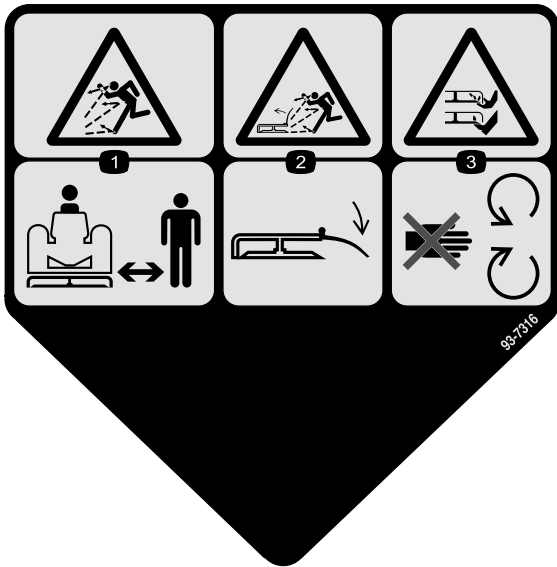

93-7316

1. Thrown object hazard—keep bystanders a safe distance from the machine.
2. Thrown object hazard, mower—keep the deflector in place.
3. Cutting/dismemberment of hand or foot—stay away from moving parts.

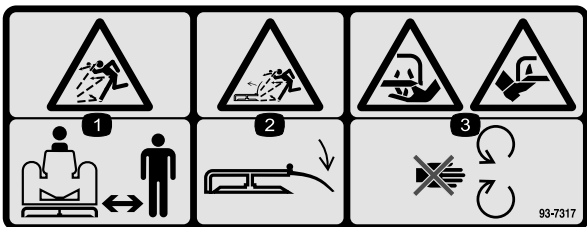

93-7317

1. Thrown object hazard—keep bystanders a safe distance from the machine.
2. Thrown object hazard, mower—keep the deflector in place.
3. Cutting/dismemberment of hand or foot—stay away from moving parts.

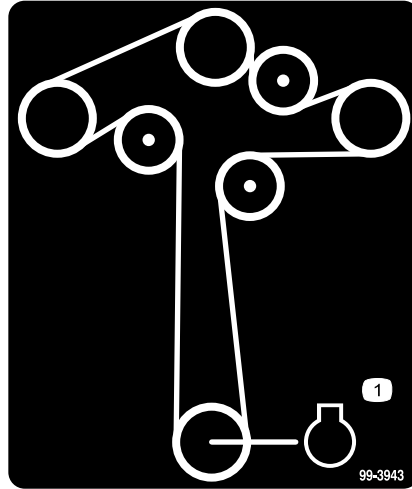

99-3943

1. Engine

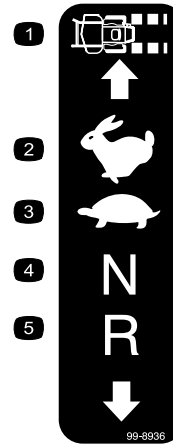

99-8936

- | | |
|------------------|------------|
| 1. Machine speed | 4. Neutral |
| 2. Fast | 5. Reverse |
| 3. Slow | |

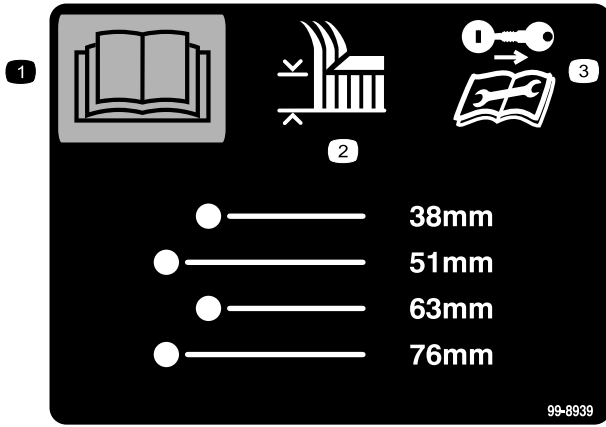

99-8939

1. Read the *Operator's Manual*.
2. Height of cut
3. Remove the ignition key and read the instructions before servicing or performing maintenance.

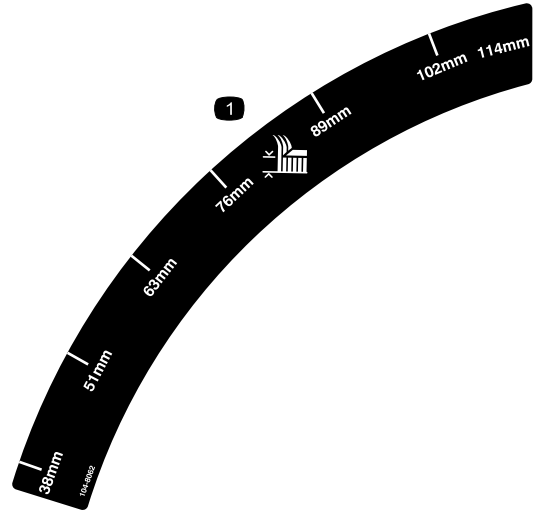

104-8062

1. Height of cut

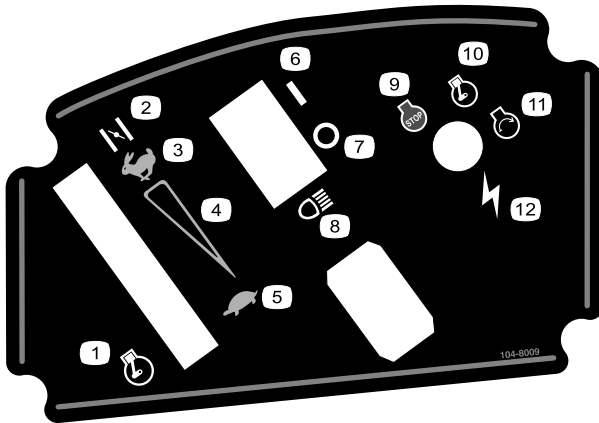

104-8009

- | | |
|--------------------------------|------------------|
| 1. Throttle | 7. Headlights |
| 2. Choke | 8. Engine—stop |
| 3. Continuous variable setting | 9. Engine—run |
| 4. Slow | 10. Engine—start |
| 5. On | 11. Ignition |
| 6. Off | |

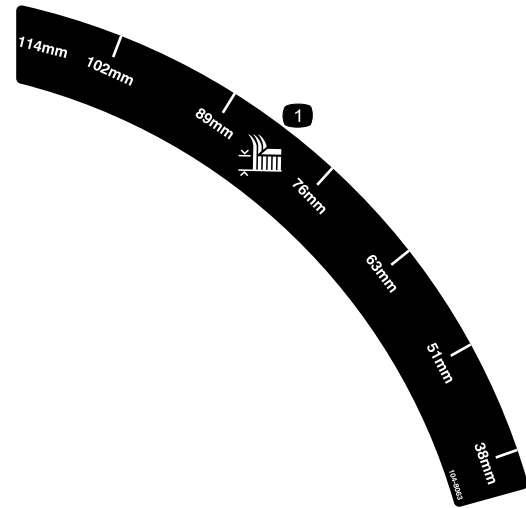

104-8063

1. Height of cut



104-8061

1. To ride the machine, pull the lever out.
2. Do not tow the machine.
3. To push the machine, push the lever in.

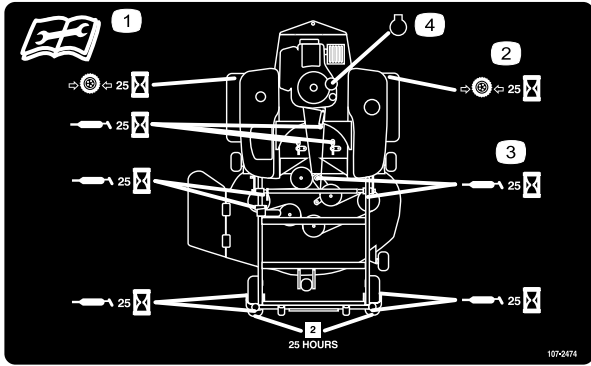

107-2474

1. Read the instructions before servicing or performing maintenance.
2. Check the tire pressure every 25 operating hours.
3. Grease every 25 operating hours.
4. Engine



Battery Symbols

Some or all of these symbols are on your battery

1. Explosion hazard
2. No fire, open flame, or smoking.
3. Caustic liquid/chemical burn hazard
4. Wear eye protection
5. Read the *Operator's Manual*.
6. Keep bystanders a safe distance from the battery.
7. Wear eye protection; explosive gases can cause blindness and other injuries
8. Battery acid can cause blindness or severe burns.
9. Flush eyes immediately with water and get medical help fast.
10. Contains lead; do not discard.

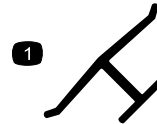

Manufacturer's Mark

1. Indicates the blade is identified as a part from the original machine manufacturer.

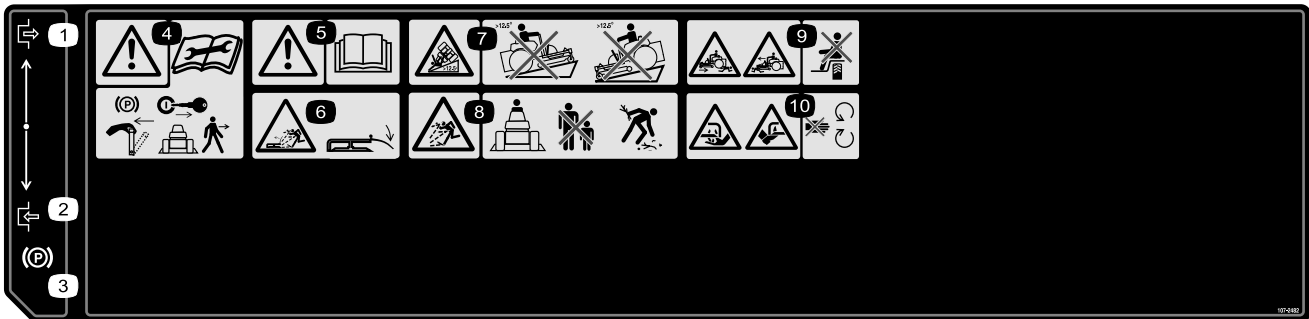

107-2482

1. Engage
2. Disengage
3. Parking brake
4. Warning—set the parking brake and remove the ignition key before leaving the machine and read the instructions before servicing or performing maintenance.
5. Warning—read the *Operator's Manual*.
6. Thrown object hazard, mower—keep the deflector in place.
7. Tipping hazard, slopes greater than 12.5 degrees—do not drive the machine on a slope greater than 12.5 degrees.
8. Thrown object hazard—keep bystanders a safe distance from the machine and pick up debris before operating.
9. Crushing/dismemberment hazard of bystanders—do not carry passengers.
10. Cutting/dismemberment hazard of hand or foot, mower blade—stay away from moving parts.

Product Overview

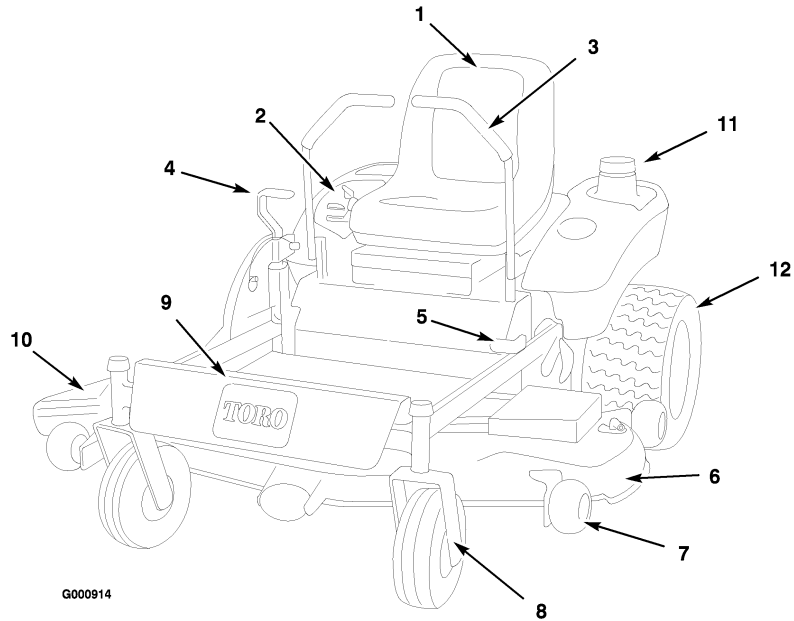

Figure 3

- | | | | |
|--------------------------|------------------------|-----------------------|----------------------|
| 1. Seat | 4. Height of cut lever | 7. Anti-scalp wheel | 10. Discharge chute |
| 2. Control panel | 5. Parking brake | 8. Front castor wheel | 11. Gas tank |
| 3. Motion control levers | 6. Mower deck | 9. Footrest | 12. Rear drive wheel |

Controls

Become familiar with all of the controls (Figure 4 and Figure 5) before you start the engine and operate the machine.

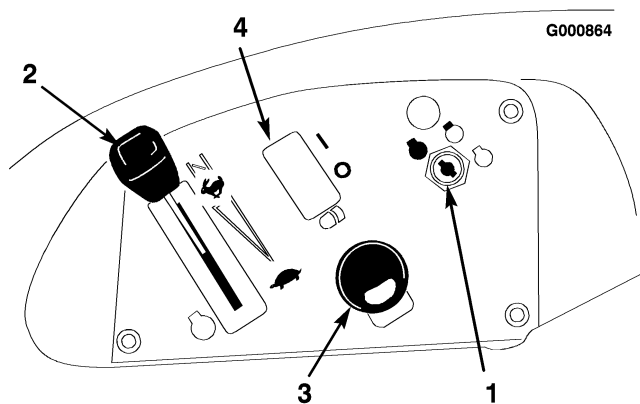

Figure 4

- | | |
|--------------------|-------------------------|
| 1. Ignition switch | 3. Power take off (PTO) |
| 2. Throttle/Choke | 4. Headlights-optional |

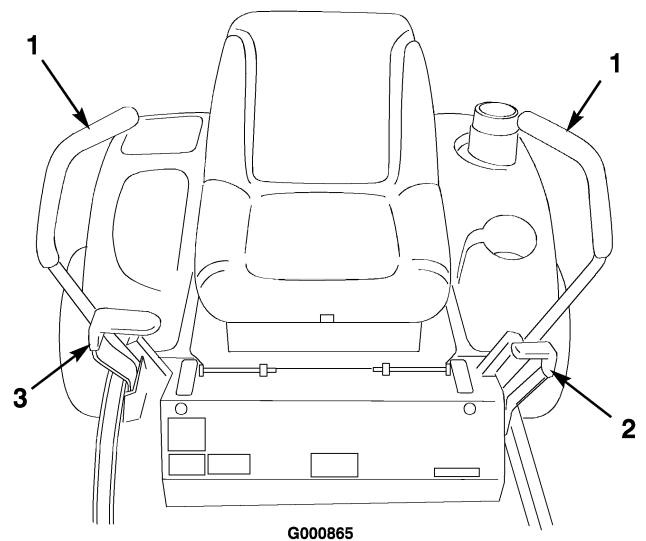

Figure 5

- | | |
|-------------------------|------------------------|
| 1. Motion control lever | 3. Height-of-cut lever |
| 2. Parking brake lever | |

Operation

Note: Determine the left and right sides of the machine from the normal operating position.

Think Safety First

Please carefully read all of the safety instructions and decals in the safety section. Knowing this information could help you, your family, pets or bystanders avoid injury.



Mowing on wet grass or steep slopes can cause sliding and loss of control.

Wheels dropping over edges can cause rollovers, which may result in serious injury, death or drowning.

To avoid loss of control and possibility of rollover:

- Do not mow near drop-offs or near water.
- Do not mow slopes greater than 12.5 degrees.
- Reduce speed and use extreme caution on slopes.
- Avoid sudden turns or rapid speed changes.

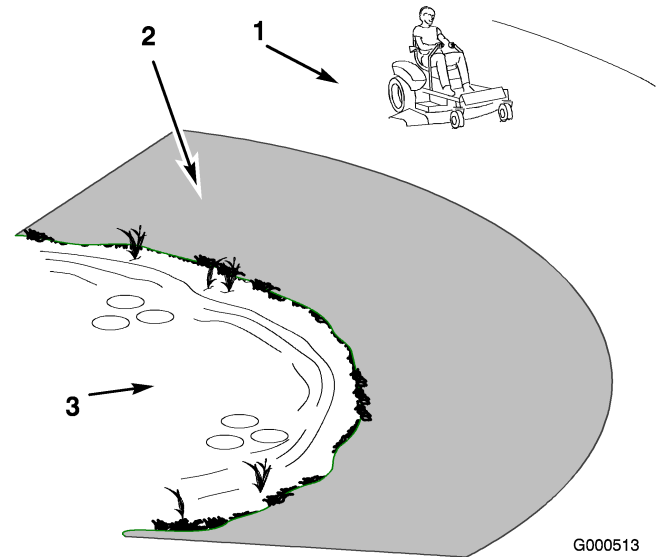

G000513

Figure 6

1. Safe Zone-use the TimeCutter here
2. Use walk behind mower and/or hand trimmer near drop-offs and water.
3. Water

Recommended Gasoline

Use UNLEADED Regular Gasoline suitable for automotive use (87 pump octane minimum). Leaded regular gasoline may be used if unleaded regular is not available.

Important: Never use methanol, gasoline containing methanol, or gasohol containing more than 10% ethanol because the fuel system could be damaged. Do not mix oil with gasoline.



In certain conditions, gasoline is extremely flammable and highly explosive. A fire or explosion from gasoline can burn you and others and can damage property.

- Fill the fuel tank outdoors, in an open area, when the engine is cold. Wipe up any gasoline that spills.
- Do not fill the fuel tank completely full. Add gasoline to the fuel tank until the level is 1/4 to 1/2 inch (6 to 13 mm) below the bottom of the filler neck. This empty space in the tank allows gasoline to expand.
- Never smoke when handling gasoline, and stay away from an open flame or where gasoline fumes may be ignited by a spark.
- Store gasoline in an approved container and keep it out of the reach of children. Never buy more than a 30-day supply of gasoline.
- Always place gasoline containers on the ground away from your vehicle before filling.
- Do not fill gasoline containers inside a vehicle or on a truck or trailer bed because interior carpets or plastic truck bed liners may insulate the container and slow the loss of any static charge.
- When practical, remove gas-powered equipment from the truck or trailer and refuel the equipment with its wheels on the ground.
- If this is not possible, then refuel such equipment on a truck or trailer from a portable container, rather than from a gasoline dispenser nozzle.
- If a gasoline dispenser nozzle must be used, keep the nozzle in contact with the rim of the fuel tank or container opening at all times until fueling is complete.



Gasoline is harmful or fatal if swallowed. Long-term exposure to vapors can cause serious injury and illness.

- Avoid prolonged breathing of vapors.
- Keep face away from nozzle and gas tank or conditioner opening.
- Keep gas away from eyes and skin.

Using Stabilizer/Conditioner

Use a fuel stabilizer/conditioner in the machine to provide the following benefits:

- Keeps gasoline fresh during storage of 90 days or less. For longer storage it is recommended that the fuel tank be drained.
- Cleans the engine while it runs
- Eliminates gum-like varnish buildup in the fuel system, which causes hard starting

Important: Do not use fuel additives containing methanol or ethanol.

Add the correct amount of gas stabilizer/conditioner to the gas.

Note: A fuel stabilizer/conditioner is most effective when mixed with fresh gasoline. To minimize the chance of varnish deposits in the fuel system, use fuel stabilizer at all times.

Filling the Fuel Tank

1. Shut the engine off and set the parking brake.
2. Clean around the fuel tank cap and remove the cap. Add unleaded regular gasoline to the fuel tank until the level is 1/4 to 1/2 inch (6 to 13 mm) below the bottom of the filler neck. This space in the tank allows gasoline to expand. Do not fill the fuel tank completely full.
3. Install the fuel tank cap securely. Wipe up any gasoline that may have spilled.

Checking the Engine Oil Level

Before you start the engine and use the machine, check the oil level in the engine crankcase; refer to

Using the Parking Brake

Always set the parking brake when you stop the machine or leave it unattended.

Setting the Parking Brake

1. Move the motion control levers (Figure 5) out to the neutral lock position.
2. Pull back and up on the parking brake lever to set the parking brake (Figure 7). The parking brake lever should stay firmly in the Engaged position.

Important: Do not engage the parking brake while the machine is moving. Damage to the drive system may occur.

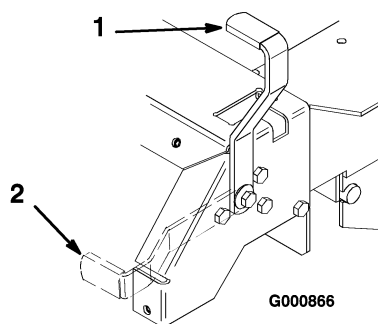

Figure 7

1. Parking brake-On
2. Parking brake-Off

Releasing the Parking Brake

Push forward and down on the parking brake lever to release the parking brake (Figure 7).

Starting and Stopping the Engine

Starting the Engine

1. Sit down on the seat and move the motion controls to neutral locked position.
2. Set the parking brake; refer to Setting the Parking Brake above.
3. Move the PTO (power take off) to Off (Figure 8).

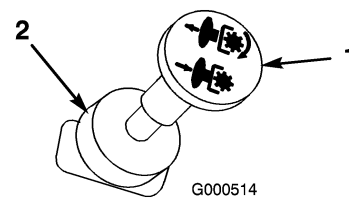

Figure 8

1. PTO-On
2. PTO-Off

4. Move the throttle lever to Choke before starting a cold engine.

Note: A warm or hot engine may require choking. After the engine starts, move the throttle lever to Fast.
5. Turn the ignition key to Start to energize the starter. When the engine starts, release the key.

Important: Do not engage the starter for more than 10 seconds at a time. If the engine fails to start, allow a 60 second cool-down period between attempts. Failure to follow these instructions can burn out the starter motor.

6. After the engine starts, move the throttle lever to Fast (Figure 9). If the engine stalls or hesitates, move the throttle lever back to Choke for a few seconds. Then move the throttle lever to the desired setting. Repeat this as required.

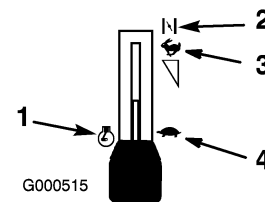

Figure 9

1. Engine
2. Choke
3. Fast
4. Slow

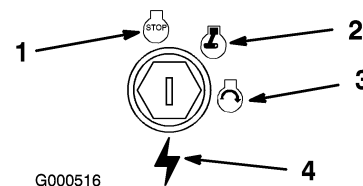

Figure 10

1. Off
2. Run
3. Start
4. Ignition

Stopping the Engine

1. Move the throttle lever to Slow (Figure 9).
2. Move the PTO to Off (Figure 8).
3. Turn the ignition key to Off (Figure 10).
4. Pull the wire off of the spark plug(s) to prevent the possibility of someone accidentally starting the machine before transporting or storing the machine.
5. Close the fuel shut-off valve under the front of the fuel tank before transporting or storing the machine.

Important: Make sure the fuel shut-off valve is closed before transporting or storing machine, as fuel leakage may occur.

Operating the Power Take Off (PTO)

The power take off (PTO) switch engages and disengages power to the electric clutch.

Engaging the PTO

1. Release pressure on the traction control levers and place the machine in neutral.
2. Move the throttle to the Fast position.
3. Pull out on the PTO switch to engage it (Figure 11).

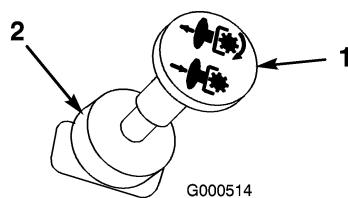

Figure 11

1. PTO-On 2. PTO-Off

Disengaging the PTO

Push the PTO switch to Off (Figure 11).

The Safety Interlock System



If safety interlock switches are disconnected or damaged the machine could operate unexpectedly causing personal injury.

- Do not tamper with the interlock switches.
- Check the operation of the interlock switches daily and replace any damaged switches before operating the machine.

Understanding the Safety Interlock System

The safety interlock system is designed to prevent the engine from starting unless:

- The parking brake is engaged.
- The PTO is disengaged.
- The motion control levers are in the neutral locked position.

The safety interlock system also is designed to stop the engine when the traction controls are moved with the parking brake on or if you rise from the seat when the PTO is engaged.

Testing the Safety Interlock System

Test the safety interlock system before you use the machine each time. If the safety system does not operate as described below, have an Authorized Service Dealer repair the safety system immediately.

1. While sitting on the seat, engage the parking brake and move the PTO to On. Try starting the engine; the engine should not crank.
2. While sitting on the seat, engage the parking brake and move the PTO to Off. Move either motion control lever (forward or reverse). Try starting the engine; the engine should not crank. Repeat with the other motion control lever.
3. While sitting on the seat, engage the parking brake, move the PTO to Off, and lock the motion control levers in neutral. Start the engine. While the engine is running, release

the parking brake, engage the PTO, and rise slightly from the seat; the engine should stop.

4. While sitting on the seat, engage the parking brake, move the PTO to Off, and lock the motion control levers in neutral. Start the engine. While the engine is running, center the motion controls and move (forward or reverse); the engine should stop.

Driving Forward or Backward

The throttle control regulates the engine speed as measured in rpm (revolutions per minute). Place the throttle control in the Fast position for best performance. Always operate in the full throttle position.



The machine can spin very rapidly. The operator may lose control of the machine and cause personal injury or damage to the machine.

- Use caution when making turns.
- Slow the machine down before making sharp turns.

Forward

1. Release the parking brake.
2. Move the levers to the center, unlocked position.
3. To go forward, slowly push the motion control levers forward (Figure 12).

Note: The engine will kill if the traction control levers are moved with the parking brake engaged.

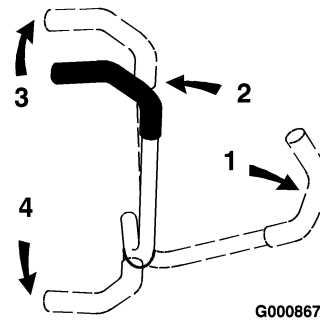

Figure 12

- | | |
|---|-------------|
| 1. Motion control lever-neutral lock position | 3. Forward |
| 2. Center unlock position | 4. Backward |

To go straight, apply equal pressure to both motion control levers (Figure 12).

To turn, release pressure on the motion control lever toward the direction you want to turn (Figure 12).

The farther you move the traction control levers in either direction, the faster the machine will move in that direction.

To stop, pull the motion control levers to neutral.

Backward

1. Move the levers to the center, unlocked position.
2. To go backward, slowly pull the motion control levers rearward (Figure 12).

To go straight, apply equal pressure to both motion control levers (Figure 12).

To turn, release the pressure on the motion control lever toward the direction you want to turn (Figure 12).

To stop, push the motion control levers to neutral.

Stopping the Machine

To stop the machine, move the traction control levers to neutral and separate to lock, disengage the PTO, and turn the ignition key to Off to stop the engine. Also set the parking brake when you leave the machine; refer to Setting the Parking Brake. Remember to remove the key from the ignition switch.

Important: Do not engage the parking brake while the machine is moving. Damage to the drive system may occur.



Children or bystanders may be injured if they move or attempt to operate the tractor while it is unattended.

Always remove the ignition key and set the parking brake when leaving the machine unattended, even if just for a few minutes.

Adjusting the Height of Cut

The height of cut is adjusted from 1-1/2 to 4-1/2 inch (38 to 114 mm) in 1/2 inch (13 mm) increments by relocating the clevis pin in different hole locations.

1. Raise the height-of-cut lever to the transport position (also the 4-1/2 inch (114 mm) cutting height position) (Figure 13).
2. To adjust, remove the hairpin cotter and clevis pin from the height-of-cut bracket (Figure 13).
3. Select the hole in the height-of-cut bracket corresponding to the height-of-cut desired, and insert the clevis pin (Figure 13).
4. Secure the clevis pin with the hairpin cotter (Figure 13).

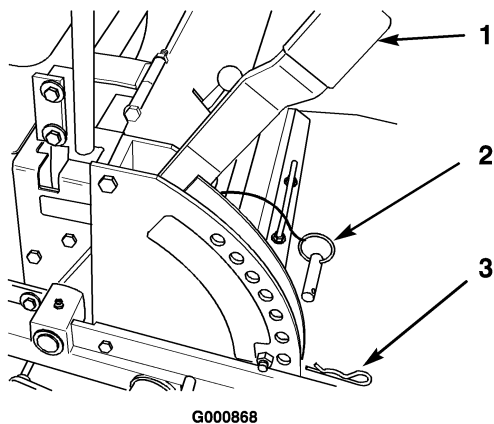

Figure 13

- | | |
|------------------------|-------------------|
| 1. Height-of-cut lever | 3. Hairpin cotter |
| 2. Clevis pin | |

5. Lower the height-of-cut lever onto the clevis pin.

Adjusting the Anti-Scalp Rollers

Whenever you change the height-of-cut it is recommended to adjust the height of the anti-scalp rollers.

1. Disengage the PTO and move the control levers to the neutral locked position and apply the parking brake.
2. Stop the engine, remove the key, and wait for all moving parts to stop before leaving the operating position.
 - A. After adjusting the height-of-cut, remove the nut and washer while holding the stud with a wrench (Figure 14).

Note: Do not remove the wheel nut and washer (Figure 14).

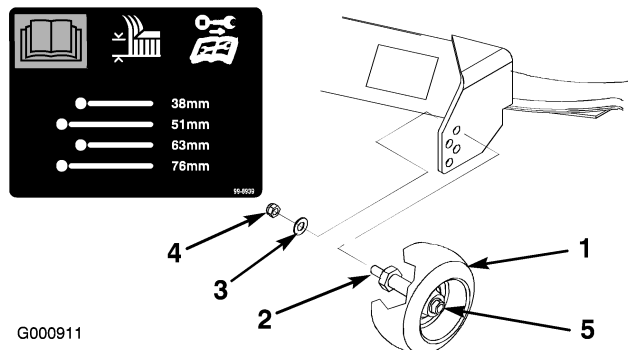

Figure 14

- | | |
|---------------|--|
| 1. Gage wheel | 4. Nut |
| 2. Stud | 5. Wheel nut and washer.
Do not remove. |
| 3. Washer | |

- B. Select a hole so that the gage wheel is positioned to the nearest corresponding height-of-cut desired (Figure 14).
3. Install the stud nut and washer (Figure 14).
4. Repeat the adjustment on the other gage wheels.

Positioning the Seat

The seat can move forward and backward. Position the seat where you have the best control of the machine and are most comfortable.

1. Raise the seat and loosen the adjustment knobs (Figure 15).
2. Move the seat to the desired position and tighten the knobs.

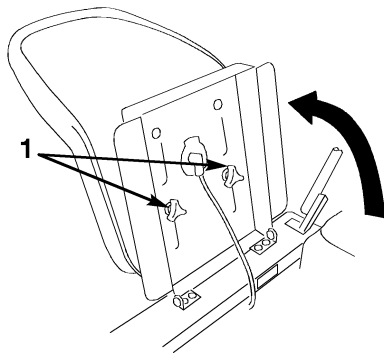

G000870

Figure 15

1. Adjustment knobs

Adjusting the Motion Control Levers

The motion control levers can be adjusted higher or lower for maximum operator comfort.

1. Remove the 2 screws and curved washers holding the control lever to the control arm shaft (Figure 16).
2. Move the control lever to the next set of holes. Secure the lever with the 2 screws and curved washers. The cupped side of the washer should be toward the control arm shaft (Figure 16).
3. Repeat the adjustment on the other control lever.

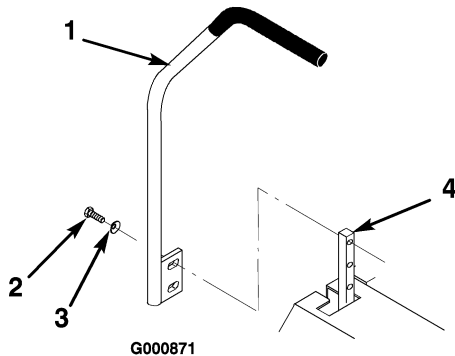

G000871

Figure 16

- | | |
|------------------|----------------------|
| 1. Control lever | 3. Curved washer |
| 2. Screw | 4. Control arm shaft |

Pushing the Machine by Hand

Important: Always push the machine by hand. Never tow the machine because damage may occur.

To Push the Machine

1. Disengage the PTO and move the control levers to the neutral locked position and apply the parking brake.
2. Stop the engine, remove the key, and wait for all moving parts to stop before leaving the operating position.
3. Pull the two bypass levers up and push them until the washer on the rod passes through the slot. Push the levers down to lock them in place (Figure 17).
4. Disengage the parking brake to push the machine.

G000872

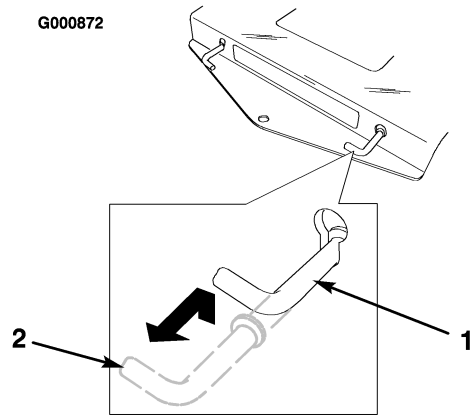

Figure 17

- | | |
|-------------------------------------|---------------------------------------|
| 1. Position for pushing the machine | 2. Position for operating the machine |
|-------------------------------------|---------------------------------------|

To Operate the Machine

Pull each bypass lever up and pull them completely out. Push the levers down (Figure 17).

Note: The machine will not drive unless the bypass levers are pulled out.

Removing the Recycler[®] Baffle

Remove the right side baffle to convert from mulching to the side discharge mode.

1. Thoroughly clean the mower.

2. Remove the knobs from the top of the mower deck securing the right side baffle (Figure 18).
3. Lift the baffle and slide it out of the interlock with the left side baffle (Figure 18).

Note: Only the right side baffle needs be removed for side discharge mowing. Retain all fasteners to return to mulching mode.

4. Install the bolts (5/16 x 5/8 inch) and locknuts (5/16 inch) from the baffle in the open holes of the mower for safety (Figure 18).

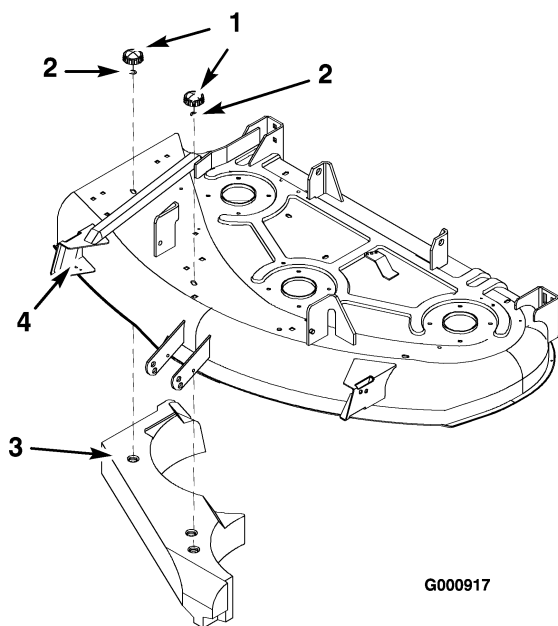

Figure 18

- | | |
|------------------|---------------------|
| 1. Knobs | 3. Rightside baffle |
| 2. Curved washer | 4. Mower deck |

Installing the Recycler® Baffle

Install the right side baffle to convert from side discharge mode to mulching.

1. Thoroughly clean the mower.
2. Remove the bolts and nuts in the holes needed for the baffle (Figure 18).
3. Install the bolts (5/16 x 5/8 inch) and locknuts (5/16 inch) in the right side baffle.
4. Place the right side baffle inside the cutting chamber so the extended lug interlocks with the left side baffle (Figure 18).
5. Secure the baffle with the curved washers and knobs removed previously (Figure 18).

Side Discharge

The mower has a hinged grass deflector that disperses clippings to the side and down toward the turf.



Without the grass deflector, discharge cover, or complete grass catcher assembly mounted in place, you and others are exposed to blade contact and thrown debris. Contact with rotating mower blade(s) and thrown debris will cause injury or death.

- Never remove the grass deflector from the mower because the grass deflector routes material down toward the turf. If the grass deflector is ever damaged, replace it immediately.
- Never put your hands or feet under the mower.
- Never try to clear discharge area or mower blades unless you move the PTO to Off and rotate the ignition key to Off. Also remove the key and pull the wire off the spark plug(s).



Open holes in the mower expose you and others to thrown debris which can cause severe injury.

- Never operate the mower without hardware mounted in all holes in the mower housing.
- Install the hardware in the mounting holes when you remove the recycling baffle.

Operating Tips

Fast Throttle Setting

For best mowing and maximum air circulation, operate the engine at Fast. Air is required to thoroughly cut grass clippings, so do not set the

height-of-cut so low as to totally surround the mower by uncut grass. Always try to have one side of the mower free from uncut grass, which allows air to be drawn into the mower.

Cutting a Lawn for the First Time

Cut grass slightly longer than normal to ensure that the cutting height of the mower does not scalp any uneven ground. However, the cutting height used in the past is generally the best one to use. When cutting grass longer than six inches tall, you may want to cut the lawn twice to ensure an acceptable quality of cut.

Cut 1/3 of the Grass Blade

It is best to cut only about 1/3 of the grass blade. Cutting more than that is not recommended unless grass is sparse, or it is late fall when grass grows more slowly.

Mowing Direction

Alternate mowing direction to keep the grass standing straight. This also helps disperse clippings which enhances decomposition and fertilization.

Mow at Correct Intervals

Normally, mow every four days. But remember, grass grows at different rates at different times. So to maintain the same cutting height, which is a good practice, mow more often in early spring. As the grass growth rate slows in mid summer, mow less frequently. If you cannot mow for an extended period, first mow at a high cutting height; then mow again two days later at a lower height setting.

Cutting Speed

To improve cut quality, use a slower ground speed.

Avoid Cutting Too Low

If the cutting width of the mower is wider than the mower you previously used, raise the cutting height to ensure that uneven turf is not cut too short.

Long Grass

If the grass is ever allowed to grow slightly longer than normal, or if it contains a high degree of

moisture, raise the cutting height higher than usual and cut the grass at this setting. Then cut the grass again using the lower, normal setting.

When Stopping

If the machine's forward motion must be stopped while mowing, a clump of grass clippings may drop onto your lawn. To avoid this, move onto a previously cut area with the blades engaged.

Keep the Underside of the Mower Clean

Clean clippings and dirt from the underside of the mower after each use. If grass and dirt build up inside the mower, cutting quality will eventually become unsatisfactory.

Blade Maintenance

Maintain a sharp blade throughout the cutting season because a sharp blade cuts cleanly without tearing or shredding the grass blades. Tearing and shredding turns grass brown at the edges, which slows growth and increases the chance of disease. Check the cutter blades daily for sharpness, and for any wear or damage. File down any nicks and sharpen the blades as necessary. If a blade is damaged or worn, replace it immediately with a genuine Toro replacement blade.

Maintenance

Note: Determine the left and right sides of the machine from the normal operating position.

Recommended Maintenance Schedule(s)

Maintenance Service Interval	Maintenance Procedure
After the first 8 operating hours	<ul style="list-style-type: none"> • Change the engine oil.
Before each use or daily	<ul style="list-style-type: none"> • Check the safety system. • Check the engine oil level (more often in dirty or dusty conditions). • Clean the air intake screen. • Check the cutting blades. • Clean the mower housing.
Every 25 hours	<ul style="list-style-type: none"> • Grease all lubrication points (more often in dusty, dirty conditions). • Service the foam air cleaner (more often in dusty, dirty conditions). • Check the battery electrolyte. • Check the tire pressure. • Check belts for wear/cracks.
Every 50 hours	<ul style="list-style-type: none"> • Service the paper air cleaner (more often in dusty, dirty conditions).
Every 100 hours	<ul style="list-style-type: none"> • Change the engine oil (more often in dusty, dirty conditions). • Check the spark plug(s).
Every 200 hours	<ul style="list-style-type: none"> • Change the oil filter. • Replace the paper air cleaner (more often in dusty, dirty conditions). • Replace the fuel filter.
Every 300 hours	<ul style="list-style-type: none"> • Clean the engine shrouds and cooling fins (more often in dusty, dirty conditions).
Before storage	<ul style="list-style-type: none"> • Perform all maintenance procedures listed above before storage. • Drain the fuel tank. • Charge the battery and disconnect the battery cables. • Paint any chipped surfaces.



If you leave the key in the ignition switch, someone could accidentally start the engine and seriously injure you or other bystanders.

Remove the key from the ignition and disconnect the wire from the spark plug(s) before you do any maintenance. Set the wire aside so that it does not accidentally contact the spark plug.

Lubrication

Lubricate the machine when shown on the Check Service Reference Aid decal (Figure 19) located beneath the seat. Grease more frequently when operating conditions are extremely dusty or sandy.

Grease with No. 2 general purpose lithium base or molybdenum base grease.

How to Grease

1. Disengage the PTO and move the control levers to the neutral locked position and apply the parking brake.
2. Stop the engine, remove the key, and wait for all moving parts to stop before leaving the operating position.

- Clean the grease fittings with a rag. Make sure to scrape any paint off of the front of the fitting(s).
- Connect a grease gun to the fitting. Pump grease into the fittings until grease begins to ooze out of the bearings.
- Wipe up any excess grease.

Where to Add Grease

Lubricate the grease fittings as shown on the Check Service Reference Aid decal (Figure 19) located beneath the seat and the mower (Figure 20).

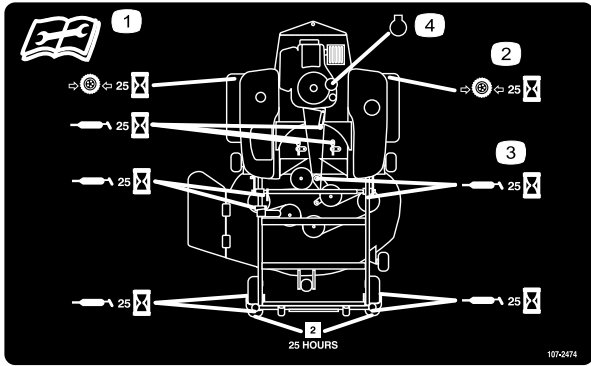

Figure 19

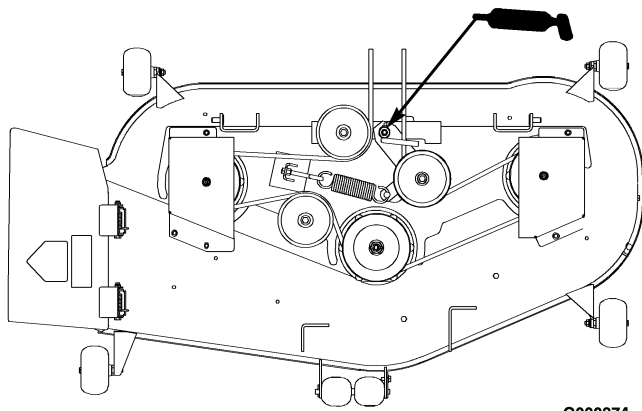

Figure 20

Top View

Engine Maintenance

Servicing the Engine Oil

Change the oil after the first 8 operating hours and every 100 operating hours thereafter.

Oil Type: Detergent oil (API service SC, SD, SE, SF, SG, or SH)

Crankcase Capacity: with filter, 51 ounce (1.5 l)

Viscosity: See the table below.

USE THESE SAE VISCOSITY OILS

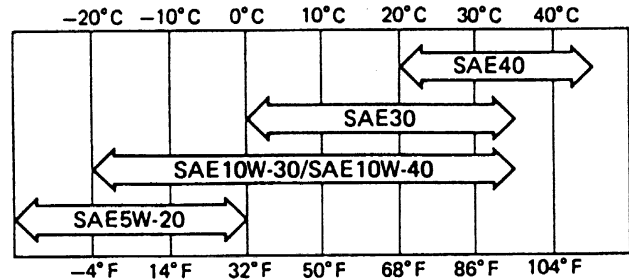

G000875

Figure 21

Checking the Oil Level

- Park the machine on a level surface, disengage the PTO, stop the engine, and remove the key.
- Disengage the PTO and move the control levers to the neutral locked position and apply the parking brake.
- Clean around the oil dipstick (Figure 22) so that dirt cannot fall into the fill hole and damage the engine.
- Unscrew the oil dipstick and wipe the metal end clean (Figure 22).

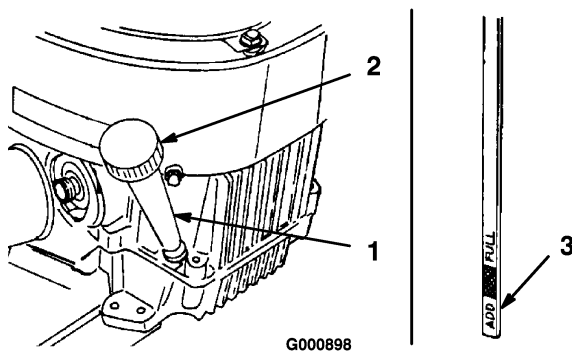

Figure 22

1. Oil dipstick
2. Filler tube
3. Metal end, dipstick

Note: Dispose of the used oil at a certified recycling center.

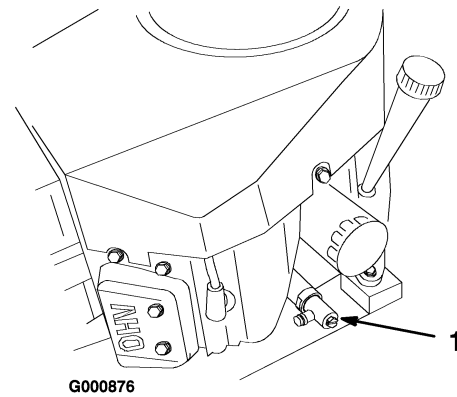

Figure 23

1. Oil drain

5. Screw the oil dipstick fully onto the fill hole. Unscrew the dipstick, pull it out, and look at the metal end. If the oil level is low, slowly pour only enough oil into the fill hole to raise the level to, but not over, the Full mark on the dipstick.

Important: Do not overfill the crankcase with oil because the engine may be damaged.

Changing and Draining the Oil

1. Start the engine and let it run for five minutes. This warms the oil so that it drains better.
2. Park the machine so that the drain side is slightly lower than the opposite side to ensure that the oil drains completely.
3. Disengage the PTO and move the control levers to the neutral locked position and apply the parking brake.
4. Stop the engine, remove the key, and wait for all moving parts to stop before leaving the operating position.
5. Slide the drain hose over the oil drain valve (Figure 23).
6. Place a pan below the oil drain hose. Use either a flat screw driver, 3/8 inch (10 mm) wrench to open valve (Figure 23).
7. Rotate valve end counterclockwise to open valve (Figure 23).
8. When oil has drained completely, rotate valve end clockwise to close the valve (Figure 23).
9. Remove the drain hose.

10. Clean around the oil dipstick and unscrew the cap (Figure 23).
11. Slowly pour approximately 80% of the specified oil into the filler cap (Figure 23). Refer to Servicing the Engine Oil, in Engine Maintenance, page 22.
12. Check the oil level; refer to Checking the Oil Level.
13. Slowly add additional oil to bring it to the full mark.

Changing the Oil Filter

Replace the oil filter every 200 hours or every other oil change.

Note: Change the oil filter more frequently when operating conditions are extremely dusty or sandy.

1. Drain the oil from the engine; refer to Changing and Draining the Oil.
2. Remove the old filter (Figure 24).
3. Apply a thin coat of new oil to the rubber gasket on the replacement filter.

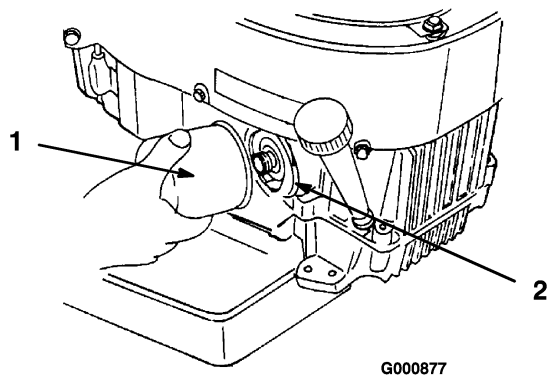

Figure 24

1. Oil filter 2. Adapter

4. Install the replacement oil filter to the adapter. Turn the oil filter clockwise until the rubber gasket contacts the filter adapter, then tighten the filter an additional 3/4 turn (Figure 24).
5. Fill the crankcase with the proper type of new oil; refer to Changing and Draining the Oil.

Servicing the Air Cleaner

Foam Element: Clean and oil after every 25 operating hours.

Paper Element: Clean after every 100 operating hours. Replace after every 200 operating hours or yearly, whichever comes first.

Note: Service the air cleaner more frequently (every few hours) if operating conditions are extremely dusty or sandy.

Removing the Foam and Paper Elements

1. Disengage the PTO and move the control levers to the neutral locked position and apply the parking brake.
2. Stop the engine, remove the key, and wait for all moving parts to stop before leaving the operating position.
3. Clean around the air cleaner to prevent dirt from getting into the engine and causing damage. Unlatch the two side latches and remove the air cleaner cover (Figure 25).
4. Carefully remove the foam element from the paper element (Figure 25).
5. Unscrew the wing nut and remove the paper element (Figure 25).

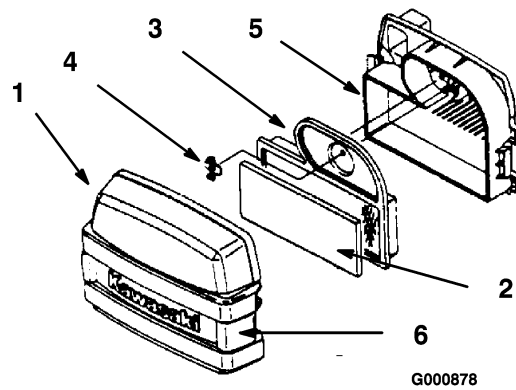

Figure 25

1. Cover 4. Wing nut
 2. Foam element 5. Air cleaner base
 3. Paper element 6. Latches

Cleaning the Foam and Paper Elements

1. Foam Element
 - A. Wash the foam element in liquid soap and warm water. When the element is clean, rinse it thoroughly.
 - B. Dry the element by squeezing it in a clean cloth (do not wring). Allow the element to air dry.
 - C. Soak the element in new engine oil. (Figure 26). Squeeze the element to remove excess oil.

Important: Replace the foam element if it is torn or worn.

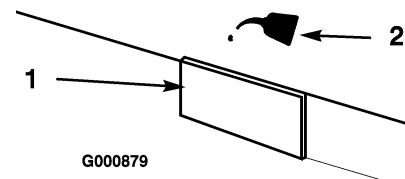

Figure 26

1. Foam element 2. Oil

2. Paper Element
 - A. Lightly tap the element on a flat surface to remove dust and dirt (Figure 27).
 - B. Inspect the element for tears, an oily film, and damage to the rubber seal.

Important: Never clean the paper element with pressurized air or liquids, such as solvent, gas, or kerosene. Replace the paper element if it is damaged or cannot be cleaned thoroughly.

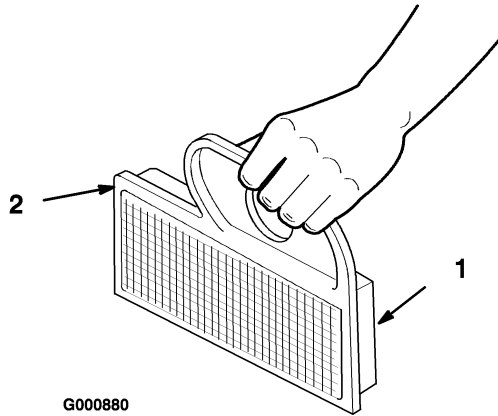

Figure 27

1. Paper element
2. Rubber seal

Cleaning the Cooling System

Clean the air intake screen from grass and debris before each use.

Clean the cooling fins and engine shrouds every 300 hours or yearly, whichever comes first.

1. Disengage the PTO and move the control levers to the neutral locked position and apply the parking brake.
2. Stop the engine, remove the key, and wait for all moving parts to stop before leaving the operating position.
3. Remove the air intake screen, cylinder covers, and fan housing.
4. Clean debris and grass from the parts.
5. Install the air intake screen, cylinder covers, and fan housing.

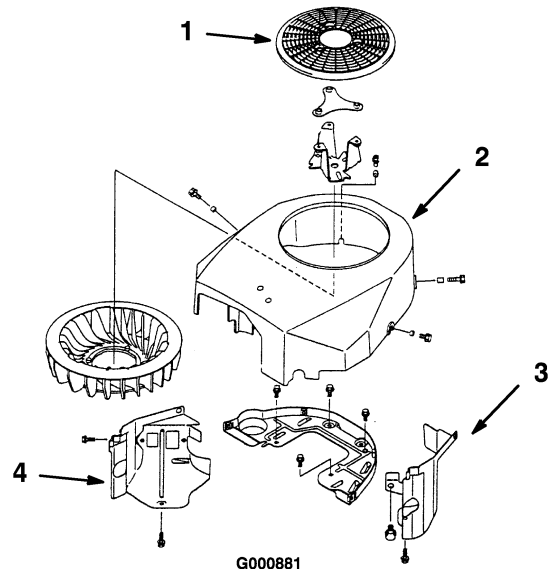

Figure 28

1. Air intake screen
2. Fan housing
3. Cylinder cover
4. Cylinder cover

Fuel System Maintenance

Replacing the Fuel Filter

Replace the fuel filter after every 200 operating hours or yearly, whichever occurs first.

Never install a dirty filter if it is removed from the fuel line.

1. Disengage the PTO and move the control levers to the neutral locked position and apply the parking brake.
2. Stop the engine, remove the key, and wait for all moving parts to stop before leaving the operating position.
3. Close the fuel shut-off valve located under the front of the fuel tank.
4. Squeeze the ends of the hose clamps together and slide them away from the filter (Figure 29).
5. Remove the filter from the fuel lines.
6. Install a new filter and move the hose clamps close to the filter (Figure 29).
7. Open the fuel shut-off valve.

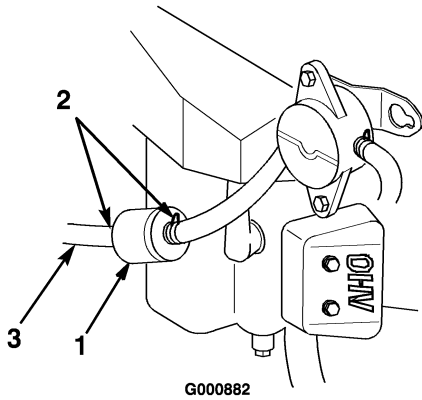

Figure 29

1. Fuel filter
2. Hose clamp
3. Fuel line

Draining the Fuel Tank



In certain conditions, gasoline is extremely flammable and highly explosive. A fire or explosion from gasoline can burn you and others and can damage property.

- Drain gasoline from the fuel tank when the engine is cold. Do this outdoors in an open area. Wipe up any gasoline that spills.
- Never smoke when draining gasoline, and stay away from an open flame or where a spark may ignite the gasoline fumes.

1. Park the machine on a level surface, to ensure that the fuel tank drains completely.
2. Disengage the PTO and move the control levers to the neutral locked position and apply the parking brake.
3. Stop the engine, remove the key, and wait for all moving parts to stop before leaving the operating position.
4. Close the fuel shut-off valve located under the front of the fuel tank.
5. Loosen the hose clamp at the fuel filter and slide it up the fuel line away from the fuel filter (Figure 29).
6. Pull the fuel line off of the fuel filter (Figure 29).
7. Open the fuel shut-off valve. Allow gasoline to drain into a gas can or drain pan.

Note: Now is the best time to install a new fuel filter because the fuel tank is empty.

Electrical System Maintenance

Spark Plug

Check the spark plug(s) after every 200 operating hours. Make sure that the air gap between the center and side electrodes is correct before installing the spark plug. Use a spark plug wrench for removing and installing the spark plug(s) and a gapping tool/feeler gauge to check and adjust the air gap. Install a new spark plug(s) if necessary.

Type: Champion RC12YC (or equivalent)

Air Gap: 0.030 inch (0.76 mm)

Removing the Spark Plug(s)

1. Disengage the PTO and move the control levers to the neutral locked position and apply the parking brake.
2. Stop the engine, remove the key, and wait for all moving parts to stop before leaving the operating position.
3. Pull the wire(s) off of the spark plug(s) (Figure 30). Clean around the spark plug(s) to prevent dirt from falling into the engine and potentially causing damage.
4. Remove the spark plug(s) and metal washer.

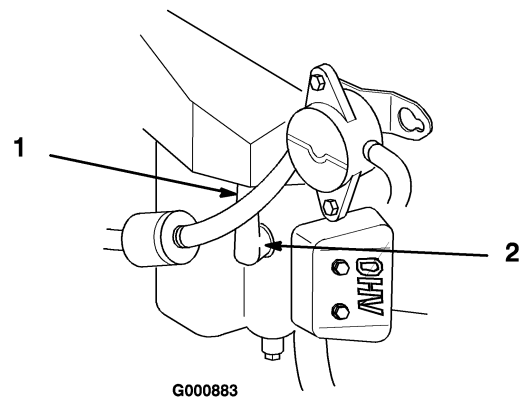

Figure 30

1. Spark plug wire installed
2. Spark plug

Checking the Spark Plug

1. Look at the center of the spark plug(s) (Figure 31). If you see light brown or gray on the insulator, the engine is operating properly. A black coating on the insulator usually means the air cleaner is dirty.

Important: Never clean the spark plug(s). Always replace the spark plug(s) when it has a black coating, worn electrodes, an oily film, or cracks.

2. Check the gap between the center and side electrodes (Figure 31). Bend the side electrode (Figure 31) if the gap is not correct.

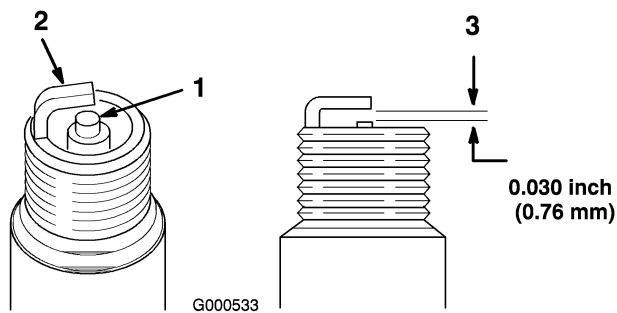

Figure 31

1. Center electrode insulator
2. Side electrode
3. Air gap (not to scale)

Installing the Spark Plug(s)

1. Install the spark plug(s). Make sure that the air gap is set correctly.
2. Tighten the spark plug(s) to 11 ft.-lb. (15 N·m).
3. Push the wire(s) onto the spark plug(s) (Figure 30).

Servicing the Battery

Check the electrolyte level in the battery every 25 hours. Always keep the battery clean and fully charged. Use a paper towel to clean the battery case. If the battery terminals are corroded, clean them with a solution of four parts water and one part baking soda. Apply a light coating of grease to the battery terminals to prevent corrosion.

Voltage: 12 v

Removing the Battery



Battery terminals or metal tools could short against metal tractor components causing sparks. Sparks can cause the battery gasses to explode, resulting in personal injury.

- When removing or installing the battery, do not allow the battery terminals to touch any metal parts of the tractor.
- Do not allow metal tools to short between the battery terminals and metal parts of the tractor.

1. Disengage the PTO and move the control levers to the neutral locked position and apply the parking brake.
2. Stop the engine, remove the key, and wait for all moving parts to stop before leaving the operating position.
3. Tip the seat forward to see the battery.
4. Disconnect the negative (black) ground cable from the battery post (Figure 32).



Incorrect battery cable routing could damage the tractor and cables causing sparks. Sparks can cause the battery gasses to explode, resulting in personal injury.

- Always disconnect the negative (black) battery cable before disconnecting the positive (red) cable.
- Always connect the positive (red) battery cable before connecting the negative (black) cable.

5. Slide the rubber cover up the positive (red) cable. Disconnect the positive (red) cable from the battery post (Figure 32).
6. Remove the battery hold-down (Figure 32) and lift the battery from the battery tray.

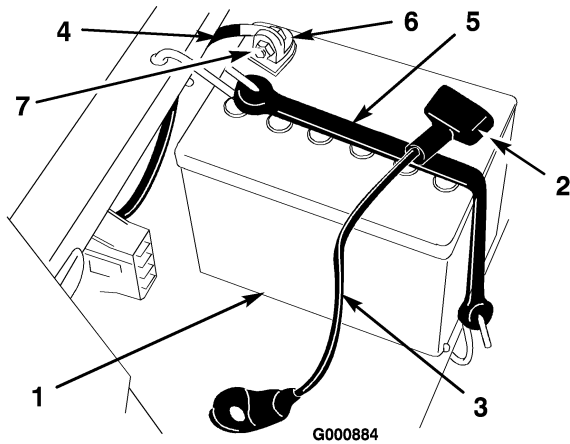

Figure 32

- | | |
|---------------------------|----------------------|
| 1. Battery | 5. Battery hold-down |
| 2. Terminal boot | 6. Bolt and washer |
| 3. Positive battery cable | 7. Nut |
| 4. Negative battery cable | |

Installing the Battery

1. Position the battery in the tray with the terminal posts away from the control panel (Figure 32).
2. Install the positive (red) battery cable to the positive (+) battery terminal.
3. Install the negative battery cable to the negative (-) battery terminal.
4. Secure the cables with 2 bolts (1/4 x 3/4 inch), washers (1/4 inch), and nuts (1/4 inch) (Figure 32).
5. Slide the red terminal boot onto the positive (red) battery post.
6. Secure the battery with the hold-down (Figure 32).

Checking the Electrolyte Level



Battery electrolyte contains sulfuric acid which is a deadly poison and causes severe burns.

- Do not drink electrolyte and avoid contact with skin, eyes or clothing. Wear safety glasses to shield your eyes and rubber gloves to protect your hands.
- Fill the battery where clean water is always available for flushing the skin.

1. Tip the seat forward to see the battery.
2. Look at the side of the battery. The electrolyte must be up to the Upper line (Figure 33). Do not allow the electrolyte to fall below the Lower line (Figure 33).

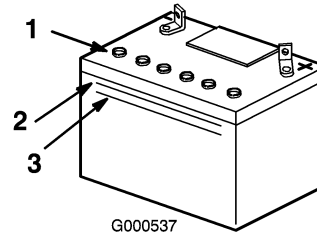

Figure 33

- | | |
|---------------|---------------|
| 1. Vent caps | 3. Lower line |
| 2. Upper line | |

3. If the electrolyte is low, add the required amount of distilled water; refer to Adding Water to the Battery.

Adding Water to the Battery

The best time to add distilled water to the battery is just before you operate the machine. This lets the water mix thoroughly with the electrolyte solution.

1. Remove the battery from the tractor; refer to Removing the Battery.

Important: Never fill the battery with distilled water while the battery installed in the tractor. Electrolyte could be spilled on other parts and cause corrosion.

2. Clean the top of the battery with a paper towel.
3. Remove the vent caps from the battery (Figure 33).
4. Slowly pour distilled water into each battery cell until the electrolyte level is up to the Upper line (Figure 33) on the battery case.

Important: Do not overfill the battery because electrolyte (sulfuric acid) can cause severe corrosion and damage to the chassis.

5. Wait five to ten minutes after filling the battery cells. Add distilled water, if necessary, until the electrolyte level is up to the Upper line (Figure 33) on the battery case.
6. Reinstall the battery vent caps.

Charging the Battery

Important: Always keep the battery fully charged (1.260 specific gravity). This is especially important to prevent battery damage when the temperature is below 32°F (0°C).

1. Remove the battery from the chassis; refer to Removing the Battery.
2. Check the electrolyte level; refer to Checking the Electrolyte Level.
3. Make sure that the vent caps are installed in the battery. Charge the battery for 1 hour at 25 to 30 amps or 6 hours at 4-6 amps. Do not overcharge the battery.
4. When the battery is fully charged, unplug the charger from the electrical outlet, then disconnect the charger leads from the battery posts (Figure 34).

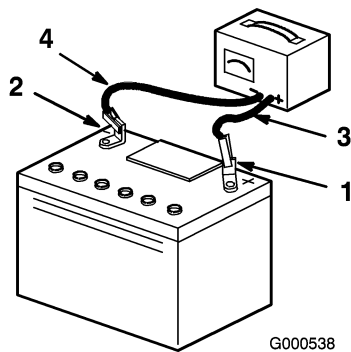

Figure 34

- | | |
|--------------------------|---------------------------|
| 1. Positive battery post | 3. Red (+) charger lead |
| 2. Negative battery post | 4. Black (-) charger lead |

5. Install the battery in the tractor and connect the battery cables; refer to Installing the Battery.

Note: Do not run the tractor with the battery disconnected, electrical damage may occur.

Servicing the Fuses

Service Interval/Specification

The electrical system is protected by fuses. It requires no maintenance; however, if a fuse blows, check the component/circuit for a malfunction or short.

Fuse:

- Main F1–30 amp, blade-type

- Charge Circuit F2–25 amp, blade-type
 - Optional Headlight Kit–10 amp, blade type
1. Raise the seat to gain access to the fuse holder (Figure 35).
 2. To replace a fuse, pull out on the fuse to remove it (Figure 35).

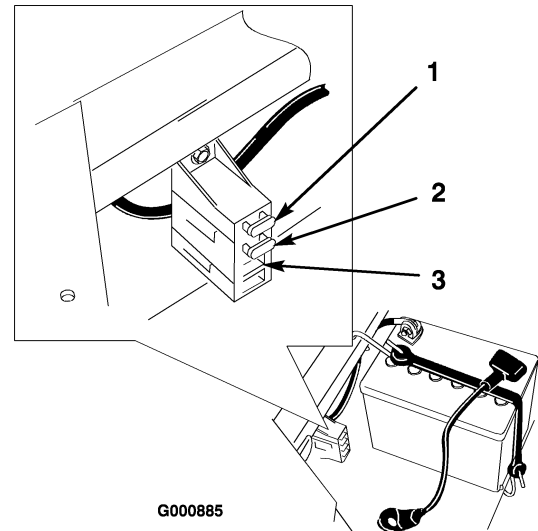

Figure 35

- | | |
|--------------------------|--------------------------------------|
| 1. Main–30 amp | 3. For optional Headlight Kit–10 amp |
| 2. Charge circuit–25 amp | |

Drive System Maintenance

Checking the Tire Pressure

Maintain the air pressure in the front and rear tires as specified. Uneven tire pressure can cause uneven cut. Check the pressure at the valve stem after every 50 operating hours or monthly, whichever occurs first (Figure 36). Check the tires when they are cold to get the most accurate pressure reading.

Rear Tires: 13 psi (90 kPa)

Front Tires (castor wheels): 35 psi (139 kPa)

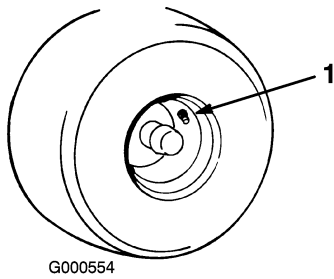

Figure 36

1. Valve stem

Mower Maintenance

Servicing the Cutting Blades

Maintain sharp blades throughout the cutting season because sharp blades cut cleanly without tearing or shredding the grass blades. Tearing and shredding turns grass brown at the edges, which slows growth and increases the chance of disease.

Check the cutter blades daily for sharpness, and for any wear or damage. File down any nicks and sharpen the blades as necessary. If a blade is damaged or worn, replace it immediately with a genuine Toro replacement blade. For convenient sharpening and replacement, you may want to keep extra blades on hand.



A worn or damaged blade can break, and a piece of the blade could be thrown into the operator's or bystander's area, resulting in serious personal injury or death.

- Inspect the blade periodically for wear or damage.
- Replace a worn or damaged blade.

Before Inspecting or Servicing the Blades

Park the machine on a level surface, disengage the PTO, and set the parking brake. Stop the engine, remove the key, and disconnect the spark plug wire(s) from the spark plug(s).

Inspecting the Blades

1. Inspect the cutting edges (Figure 37). If the edges are not sharp or have nicks, remove and

sharpen the blades; refer to Sharpening the Blades.

2. Inspect the blades, especially the curved area (Figure 37). If you notice any damage, wear, or a slot forming in this area (item 3 in Figure 37), immediately install a new blade.

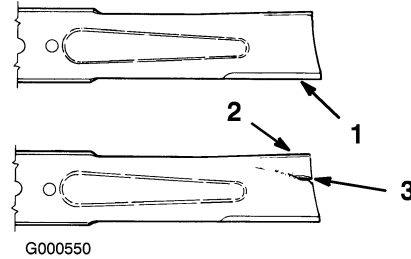

Figure 37

1. Cutting edge
2. Curved area
3. Wear/slot forming

Checking for Bent Blades

1. Disengage the PTO and move the control levers to the neutral locked position and apply the parking brake.
2. Stop the engine, remove the key, and wait for all moving parts to stop before leaving the operating position.
3. Rotate the blades until the ends face forward and backward (Figure 38). Measure from a level surface to the cutting edge of the blades (Figure 39). Note this dimension.

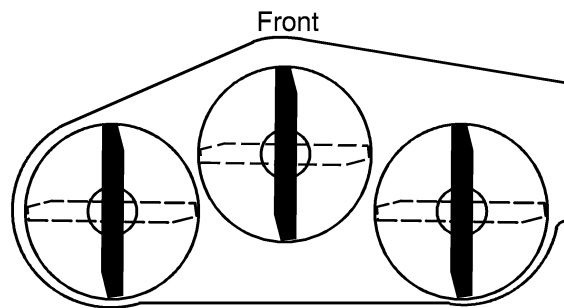
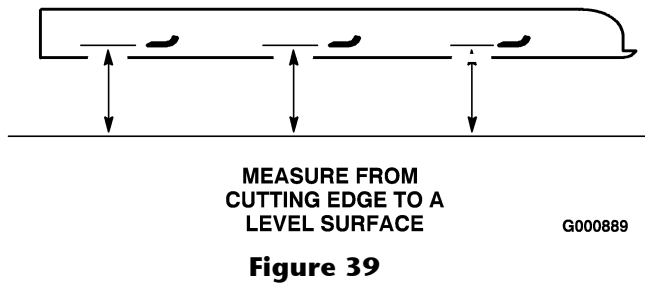

Figure 38



4. Rotate the opposite ends of the blades forward.
5. Measure from a level surface to the cutting edge of the blades at the same position as in step 3 above. The difference between the dimensions obtained in steps 3 and 4 must not exceed 1/8 inch (3 mm). If this dimension exceeds 1/8 inch (3 mm), the blade is bent and must be replaced; refer to Removing the Blades and Installing the Blades.

A blade that is bent or damaged could break apart and could seriously injure or kill you or bystanders.

- Always replace bent or damaged blade with a new blade.
- Never file or create sharp notches in the edges or surfaces of blade.

Removing the Blades

The blades must be replaced if a solid object is hit, if the blade is out of balance, or the blade is bent. To ensure optimum performance and continued safety conformance of the machine, use genuine Toro replacement blades. Replacement blades made by other manufacturers may result in non-conformance with safety standards.

Hold the blade end using a rag or thickly-padded glove. Remove the blade bolt, curved washer, stiffener and blade from the spindle shaft (Figure 40).

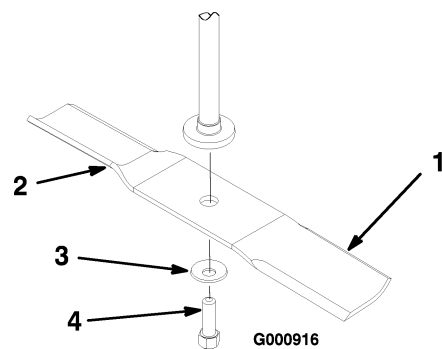

Figure 40

- | | |
|-----------------------|---------------|
| 1. Sail area of blade | 4. Blade bolt |
| 2. Blade | 5. Stiffener |
| 3. Curved washer | |

Sharpening the Blades

1. Use a file to sharpen the cutting edge at both ends of the blade (Figure 41). Maintain the original angle. The blade retains its balance if the same amount of material is removed from both cutting edges.

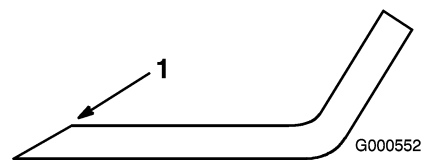

Figure 41

1. Sharpen at original angle

2. Check the balance of the blade by putting it on a blade balancer (Figure 42). If the blade stays in a horizontal position, the blade is balanced and can be used. If the blade is not balanced, repeat the sharpening procedure on the heavier side until the blade is balanced.

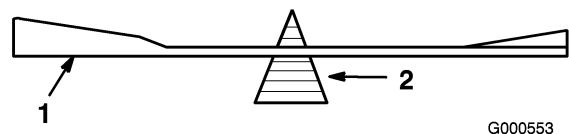

Figure 42

- | | |
|----------|-------------|
| 1. Blade | 2. Balancer |
|----------|-------------|

Installing the Blades

1. Install the blade onto the spindle shaft with the stiffener (Figure 40).

Important: The curved part of the blade must be pointing upward toward the inside of the mower to ensure proper cutting.

2. Install the curved washer (cupped side toward the blade) and blade bolt (Figure 40). Torque the blade bolt to 35-65 ft-lb (47-88 N·m).

Leveling the Mower from Side-to-Side

The mower blades must be level from side to side. Check the side-to-side level any time you install the mower or when you see an uneven cut on your lawn.

1. Position the mower on a flat surface. Disengage the PTO, set the parking brake, stop the engine, and remove the key. Disconnect the spark plug wire(s) from the spark plug(s).
2. Check the air pressure of all four tires. If needed, adjust to the recommended inflation; refer to Tire Press.
3. Set the height-of-cut at 3 inch (76 mm).
4. Carefully rotate the blade(s) from side to side (Figure 43). Measure between the outside cutting edges and the flat surface (Figure 43). If both measurements are not within 3/16 inch (4.75 mm), an adjustment is required; refer to steps 5 and 6.

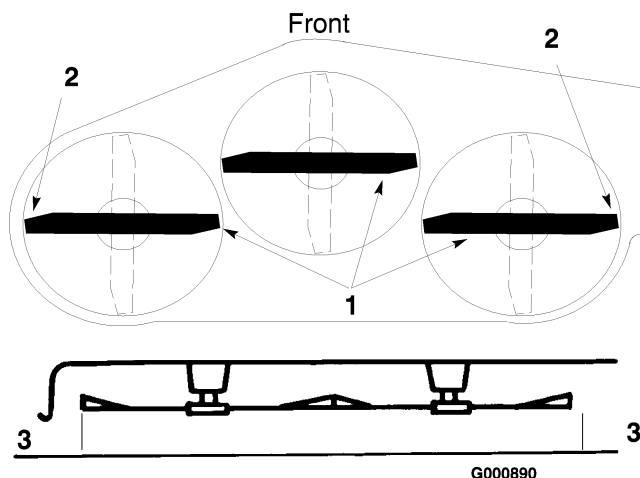

Figure 43

1. Blades side to side
2. Outside cutting edges
3. Measure here

5. Remove the hairpin cotter and washer from the leveling bracket (Figure 44). To level the blade(s), reposition the leveling bracket(s) in a different hole and install the washer and

hairpin cotter. (Figure 44). A front hole lowers the blade height and a rear hole raises its height. Adjust both sides as required.

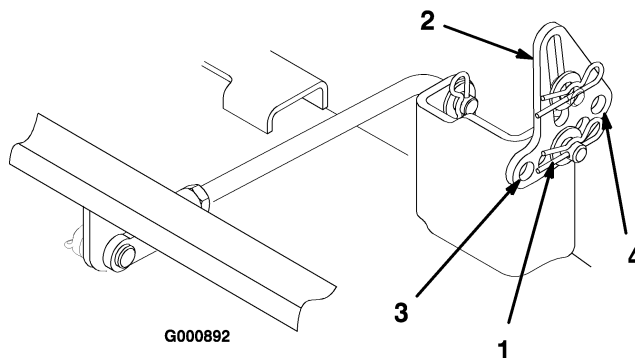

Figure 44

1. Hairpin cotter and washer
2. Leveling bracket
3. Front hole
4. Rear hole

6. Check the front-to-rear blade slope; refer to Adjusting the Front-to-Rear Blade Slope.

Adjusting the Front-to-Rear Blade Slope

Check the front-to-rear blade level any time you install the mower. If the front of the mower is more than 5/16 inch (7.9 mm) lower than the rear of the mower, adjust the blade level using the following instructions:

1. Position the mower on a flat surface.
2. Disengage the PTO and move the control levers to the neutral locked position and apply the parking brake.
3. Stop the engine, remove the key, and wait for all moving parts to stop before leaving the operating position.
4. Check the air pressure of all four tires. If needed, adjust to the recommended inflation; refer to Tire Press.
5. Check and adjust the side-to-side blade level if you have not checked the setting; refer to Leveling the Mower from Side-to-Side.
6. Measure the length of the rear trunion rod (Figure 45). If the rod length is not 11-1/2 inch (29.2 cm), remove the clevis pin and cotter pin from the end of the rod (Figure 45), loosen the jam nut, and turn the yoke until the 11-1/2 inch (29.3 cm) dimension is obtained.

- Then secure the yoke with the clevis pin and cotter pin. Repeat this procedure on the opposite side of the mower.

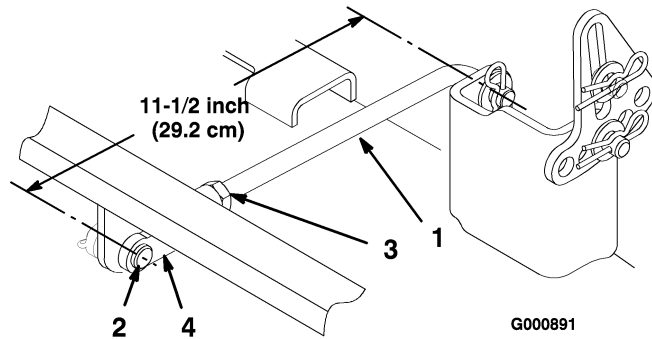

Figure 45

- Rear trunion rod
- Clevis pin and cotter pin
- Jam nut
- Yoke

- Set the height-of-cut at 3 inch (76 mm) and carefully rotate the blades so they are facing front to rear (Figure 46).
- Measure between the tip of the front blade (Figure 46) and the tip of the rear blade to the flat surface. If the front blade tip is not 1/16-5/16 inch (1.6-7.9 mm) lower than the rear blade tip, adjust the front trunion rods.

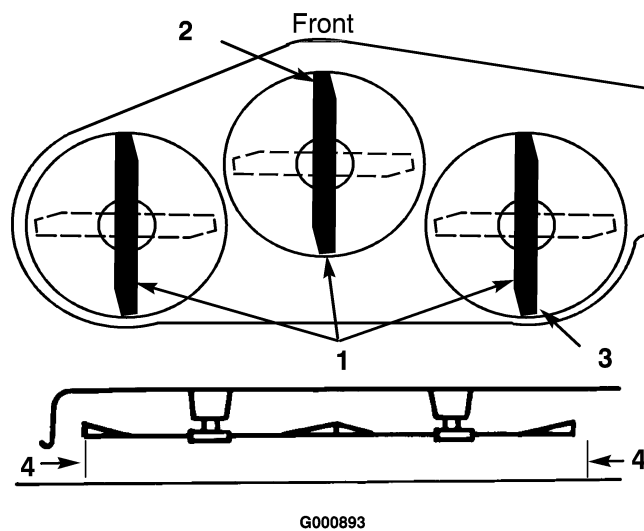

Figure 46

- Blade front to rear
- Measure front blade tip
- Measure rear blade tip
- Measure here

- To adjust the front-to-rear blade slope, remove the hairpin cotter and clevis pin from the front trunion yokes and loosen the jam nuts (Figure 47).

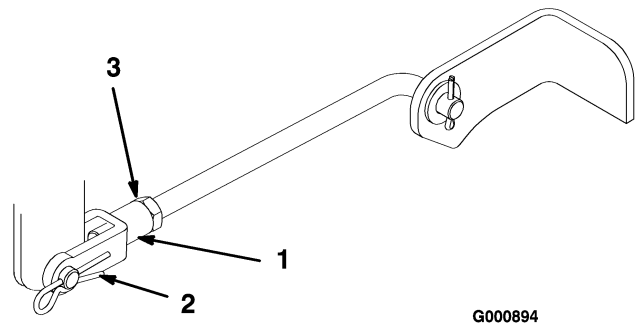

Figure 47

- Front trunion rod yoke
- Hairpin cotter
- Jam nut

- Rotate the yokes on the rods to change the adjustment (Figure 47). To raise the front of the mower, tighten the yokes (shorten the rods). To lower the front of the mower, loosen the yokes (lengthen the rods).
- After adjusting both trunion rod yokes evenly, secure the yokes with the hairpin cotters. Check the front-to-rear level again. Continue adjusting the yokes until the front blade tip is 1/16-5/16 inch (1.6-7.9 mm) lower than the rear blade tip (Figure 46).
- When the front-to-rear blade slope is correct, tighten the jam nuts (Figure 45 and Figure 47).
- Recheck the side-to-side level of the mower; refer to Leveling the Mower from Side-to-Side.
- Check the height of the anti-scalp rollers; refer to Adjusting the Anti-Scalp Rollers.

Removing the Mower

- Park the machine on a level surface.
- Disengage the PTO and move the control levers to the neutral locked position and apply the parking brake.
- Stop the engine, remove the key, and wait for all moving parts to stop before leaving the operating position.
- Lower the height-of-cut lever to the lowest position.
- Remove the hairpin cotter and clevis pin from the front trunion yokes (Figure 48).

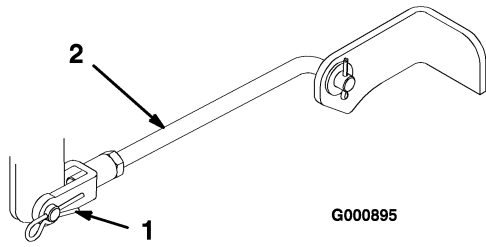

Figure 48

1. Hairpin cotter and clevis pin 2. Front trunion

6. Remove the hairpin cotter and clevis pin from the rear trunion rod (Figure 49) on each side of the mower.
7. Remove the hairpin cotter and washer at the mower leveling brackets (Figure 49) on each side of the mower. Note which hole the leveling bracket is mounted in for future installation. Slide the brackets off of the mounting pin.

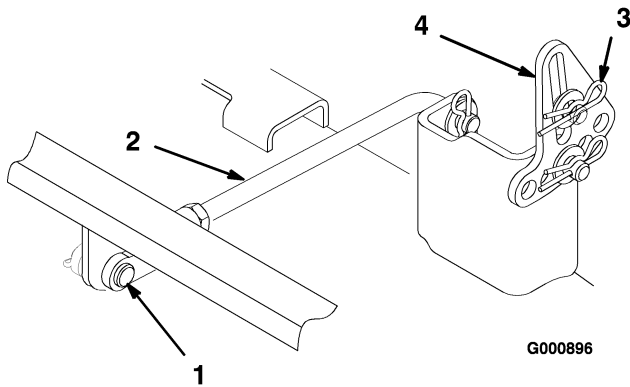

Figure 49

1. Hairpin cotter and clevis 3. Hairpin cotter and washer pin
2. Rear trunion rod 4. Leveling bracket

8. Slide the mower rearward to remove the mower belt from the engine pulley.
9. Slide the mower out from underneath the tractor.

Note: Retain all parts for future installation.

Inspecting the Belts

Inspect all belts every 100 hours.

Check the belts for cracks, frayed edges, burn marks, or any other damage. Replace damaged belts.

Squealing when the belt is rotating, blades slipping when cutting grass, frayed belt edges, burn marks, and cracks are signs of a worn mower belt. Replace the mower belt if any of these conditions are evident.

Replacing the Mower Belt

1. Stop the engine, set the parking brake, remove the key, and disconnect the spark plug wire(s) from the spark plug(s).
2. Set the height-of-cut at 1-1/2 inch (38 mm).
3. Remove the belt covers over the outside spindles.
4. Pull the idler pulley in the direction shown in Figure 50 and roll the belt off of the pulleys.

Note: Do not remove the spring.

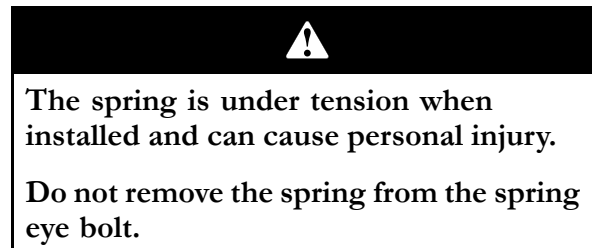

5. Route the new belt through the idler arm and around the idler pulley (Figure 50).

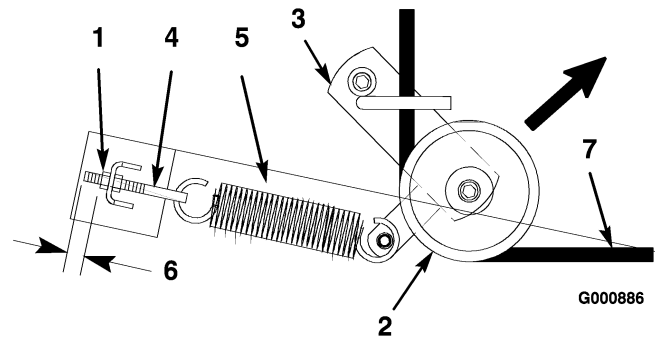

Figure 50

Top View

1. Outer nut 5. Spring
2. Idler pulley 6. 1/8 inch (3 mm)
3. Idler arm 7. Mower belt
4. Spring eye bolt

6. Pull the idler pulley in the direction shown in Figure 50 and route the belt onto the other pulleys (Figure 51).

Note: Check to ensure that the length of exposed thread on the spring eye bolt is 1/8 in. (3 mm) (Figure 50).

7. Install the belt covers over the outside spindles.

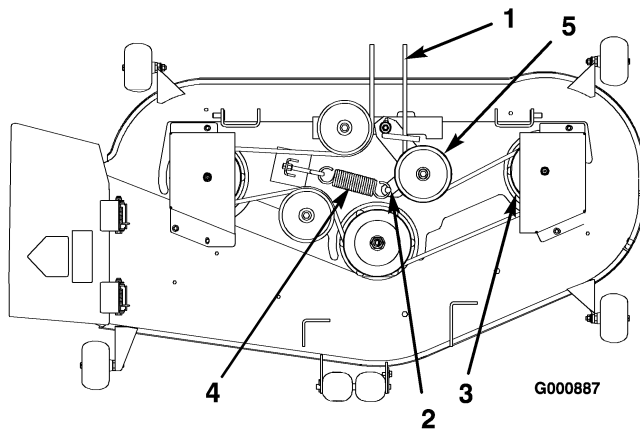

Figure 51

Top View

- | | |
|-------------------|-----------------|
| 1. Mower belt | 4. Spring |
| 2. Idler arm | 5. Idler pulley |
| 3. Outside pulley | |

Installing the Mower

1. Park the machine on a level surface.
2. Disengage the PTO and move the control levers to the neutral locked position and apply the parking brake.
3. Stop the engine, remove the key, and wait for all moving parts to stop before leaving the operating position.
4. Slide the mower under the tractor.
5. Lower the height-of-cut lever to the lowest position.
6. Attach the rear trunion rod to the tractor with the clevis pin and hairpin cotter (Figure 49) on each side of the mower.
7. Slide the leveling brackets onto the mounting pins and secure them with the washers and hairpin cotters (Figure 49).
8. Attach the front trunion rods to the tractor with the clevis pins and hairpin cotters (Figure 48).
9. Install the mower belt onto the engine pulley; refer to Replacing the Mower Belt.

Replacing the Grass Deflector



An uncovered discharge opening could allow the lawn mower to throw objects in the operator's or bystander's direction and result in serious injury. Also, contact with the blade could occur.

Never operate the lawn mower unless you install a cover plate, a mulch plate, or a grass chute and catcher.

1. Remove the locknut, bolt, and spring holding the deflector to the mower brackets (Figure 52). Remove the damaged or worn grass deflector.

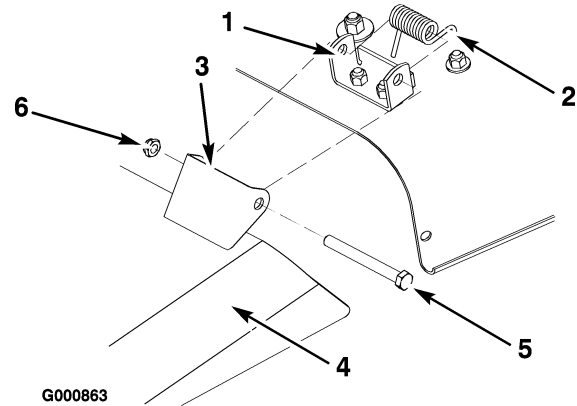

Figure 52

- | | |
|---------------------|--------------------|
| 1. Mower bracket | 4. Grass deflector |
| 2. Spring hook end | 5. Bolt |
| 3. Space for spring | 6. Locknut |
2. Place the springs into the brackets on the mower with the hooked ends over the raised back (Figure 52).
 3. Align the grass deflector with the holes in the brackets and the spring straight ends in the space under the hinge and above the deflector (Figure 52).
 4. Secure the deflector to the mower bracket with the bolts. The bolts should pass through the grass deflector, springs, and brackets.

Note: It may be helpful to press down near the end of the bolt with a 9/16 inch open end wrench to align the bolts with the second holes on the mower bracket and grass deflector.

5. Lift the grass deflector and check that it is spring loaded and pivots freely to the full down position.

Important: The grass deflector must be spring loaded in the down position. Lift the deflector up to test that it snaps to the full down position.

Cleaning

Washing the Underside of the Mower

After each use, wash the underside of the mower to prevent grass buildup, for improved mulch action, and clipping dispersal.

1. Park the machine on a hard level surface.
2. Disengage the PTO and move the control levers to the neutral locked position and apply the parking brake.
3. Stop the engine, remove the key, and wait for all moving parts to stop before leaving the operating position.
4. Attach the hose coupling to the end of the mower washout fitting, and turn the water on high (Figure 53).

Note: Spread petroleum jelly on the washout fitting O-ring to make the coupling slide on easier and protect the O-ring.

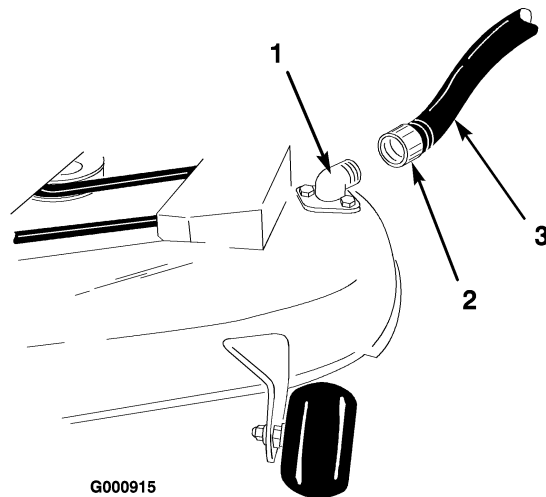

Figure 53

1. Washout fitting
2. Coupling
3. Hose

5. Lower the mower to the lowest height-of-cut.
 6. Sit on the seat and start the engine. Engage the PTO and let the mower run for one to three minutes.
 7. Disengage the PTO, stop the engine, and remove the ignition key. Wait for all moving parts to stop.
 8. Turn the water off and remove the coupling from the washout fitting.
- Note:** If the mower is not clean after one washing, soak it and let it stand for 30 minutes. Then repeat the process.
9. Run the mower again for one to three minutes to remove excess water.



A broken or missing washout fitting could expose you and others to thrown objects or blade contact. Contact with blade or thrown debris contact will cause injury or death.

- Replace broken or missing washout fitting immediately, before using mower again.
- Plug any hole(s) in mower with bolts and locknuts.
- Never put your hands or feet under the mower or through openings in the mower.

Storage

Cleaning and Storage

1. Disengage the PTO, set the parking brake, stop the engine, and remove the key.
2. Remove grass clippings, dirt, and grime from the external parts of the entire machine, especially the engine. Clean dirt and chaff from the outside of the engine cylinder head fins and blower housing.

Important: You can wash the machine with mild detergent and water. Do not pressure wash the machine. Avoid excessive use of water, especially near the control panel, engine, hydraulic pumps, and motors.

3. Service the air cleaner; refer to Servicing the Air Cleaner, Engine Maintenance, page 22.
4. Grease and oil the machine; refer to Greasing and Lubrication, Lubrication, page 21.
5. Change the crankcase oil and filter; refer to Engine Oil, Engine Maintenance, page 22.
6. Check the tire pressure; refer to Tire Pressure, Drive System Maintenance, page 29.
7. Charge the battery; refer to Servicing the Battery, Electrical System Maintenance, page 26.
8. Check the condition of the blades; refer to Cutting Blades, Mower Maintenance, page 30.
9. Prepare the machine for storage when non-use occurs over 30 days. Prepare the machine for storage as follows.
10. Add a petroleum based stabilizer/conditioner to the fuel in the tank. Follow the mixing instructions from the stabilizer manufacturer. Do not use an alcohol based stabilizer (ethanol or methanol).

Note: A fuel stabilizer/conditioner is most effective when mixed with fresh gasoline and used at all times.

- A. Run the engine to distribute the conditioned fuel through the fuel system (5 minutes).
- B. Stop the engine, allow it to cool, and drain the fuel tank; refer to Draining the Fuel Tank, Fuel System Maintenance, page 25.

- C. Restart the engine and run it until it stops.
- D. Choke or prime the engine. Start and run the engine until it will not start. Operate the primer, if equipped, several times to ensure no fuel remains in the primer system.
- E. Dispose of fuel properly. Recycle as per local codes.

Important: Do not store stabilizer/conditioned gasoline over 90 days.

11. Remove the spark plug(s) and check its condition; refer to Spark Plug, Electrical System Maintenance, page 26. With the spark plug(s) removed from the engine, pour two tablespoons of engine oil into the spark plug hole. Use the starter to crank the engine and distribute the oil inside the cylinder. Install the spark plug(s). Do not install the wire on the spark plug(s).
12. Clean any dirt and chaff from the top of the mower.
13. Scrape any heavy buildup of grass and dirt from the underside of the mower, then wash the mower with a garden hose.
14. Check the condition of the drive and mower belts.
15. Check and tighten all bolts, nuts, and screws. Repair or replace any part that is worn or damaged.
16. Paint all scratched or bare metal surfaces. Paint is available from your Authorized Service Dealer.
17. Store the machine in a clean, dry garage or storage area. Remove the key from the ignition switch and keep it in a memorable place. Cover the machine to protect it and keep it clean.

Troubleshooting

Problem	Possible Cause	Corrective Action
The engine overheats.	<ol style="list-style-type: none"> 1. The engine load is excessive. 2. The oil level in the crankcase is low. 3. The cooling fins and air passages under the engine blower housing are plugged. 4. The air cleaner is dirty. 5. Dirt, water, or stale fuel is in fuel system. 	<ol style="list-style-type: none"> 1. Reduce ground speed. 2. Add oil to the crankcase. 3. Remove the obstruction from the cooling fins and air passages. 4. Clean or replace the air cleaner element. 5. Contact an Authorized Service Dealer
The starter does not crank	<ol style="list-style-type: none"> 1. The blade control (PTO) is engaged. 2. The parking brake is not on. 3. The operator is not seated. 4. The battery is dead. 5. The electrical connections are corroded or loose. 6. A fuse is blown. 7. A relay or switch is damaged. 	<ol style="list-style-type: none"> 1. Move the PTO to Disengaged. 2. Move the motion control levers to the brake position. 3. Sit on the seat. 4. Charge the battery. 5. Check the electrical connections for good contact. 6. Replace the fuse. 7. Contact an Authorized Service Dealer.

Problem	Possible Cause	Corrective Action
The engine will not start, starts hard, or fails to keep running.	<ol style="list-style-type: none"> 1. The fuel tank is empty. 2. The fuel valve turned off. 3. The choke is not on. 4. The air cleaner is dirty. 5. The spark plug wire(s) is loose or disconnected. 6. The spark plug(s) is pitted, fouled, or the gap is incorrect. 7. There is dirt in fuel filter. 8. Dirt, water, or stale fuel is in fuel system. 9. There is incorrect fuel in the fuel tank. 10. The oil level in the crankcase is low. 	<ol style="list-style-type: none"> 1. Fill the fuel tank. 2. Open the fuel valve. 3. Move the choke lever to On. 4. Clean or replace the air cleaner element. 5. Install the wire(s) on the spark plug. 6. Install a new, correctly gapped spark plug(s). 7. Replace the fuel filter. 8. Contact an Authorized Service Dealer. 9. Drain the tank and replace the fuel with the proper type. 10. Add oil to the crankcase.
The engine loses power.	<ol style="list-style-type: none"> 1. The engine load is excessive. 2. The air cleaner is dirty. 3. The oil level in the crankcase is low. 4. The cooling fins and air passages under the engine blower housing are plugged. 5. The spark plug(s) is pitted, fouled, or the gap is incorrect. 6. The vent in the fuel cap is closed. 7. There is dirt in the fuel filter. 8. Dirt, water, or stale fuel is in the fuel system. 9. There is incorrect fuel in the fuel tank. 	<ol style="list-style-type: none"> 1. Reduce ground speed. 2. Clean the air cleaner element. 3. Add oil to the crankcase. 4. Remove the obstruction from the cooling fins and air passages. 5. Install a new, correctly gapped spark plug(s). 6. Open the vent in the fuel cap. 7. Replace the fuel filter. 8. Contact an Authorized Service Dealer. 9. Drain the tank and replace the fuel with the proper type.
The machine does not drive.	<ol style="list-style-type: none"> 1. The traction belts are worn, loose, or broken. 2. The traction belts are off of the pulleys. 	<ol style="list-style-type: none"> 1. Contact an Authorized Service Dealer. 2. Contact an Authorized Service Dealer.

Problem	Possible Cause	Corrective Action
There is abnormal vibration.	<ol style="list-style-type: none"> 1. The engine mounting bolts are loose. 2. The engine pulley, idler pulley, or blade pulley is loose. 3. The engine pulley is damaged. 4. The cutting blade(s) is/are bent or unbalanced. 5. A blade mounting bolt is loose. 6. A blade spindle is bent. 	<ol style="list-style-type: none"> 1. Tighten the engine mounting bolts. 2. Tighten the appropriate pulley. 3. Contact an Authorized Service Dealer. 4. Install a new cutting blade(s). 5. Tighten the blade mounting bolt. 6. Contact an Authorized Service Dealer.
Uneven cutting height.	<ol style="list-style-type: none"> 1. The blade(s) is not sharp. 2. A cutting blade(s) is/are bent. 3. The mower is not level. 4. An anti-scalp wheel is not set correctly. 5. The underside of the mower is dirty. 6. The tire pressure is incorrect. 7. A blade spindle is bent. 	<ol style="list-style-type: none"> 1. Sharpen the blade(s). 2. Install a new cutting blade(s). 3. Level the mower from side-to-side and front-to-rear. 4. Adjust the anti-scalp wheel height. 5. Clean the underside of the mower. 6. Adjust the tire pressure. 7. Contact an Authorized Service Dealer.
The blades do not rotate.	<ol style="list-style-type: none"> 1. The drive belt is worn, loose or broken. 2. The drive belt is off of the pulley. 3. The mower belt is worn, loose, or broken. 	<ol style="list-style-type: none"> 1. Install a new drive belt. 2. Install the drive belt and check the adjusting shafts and belt guides for the correct position. 3. Install a new mower belt.

Schematics

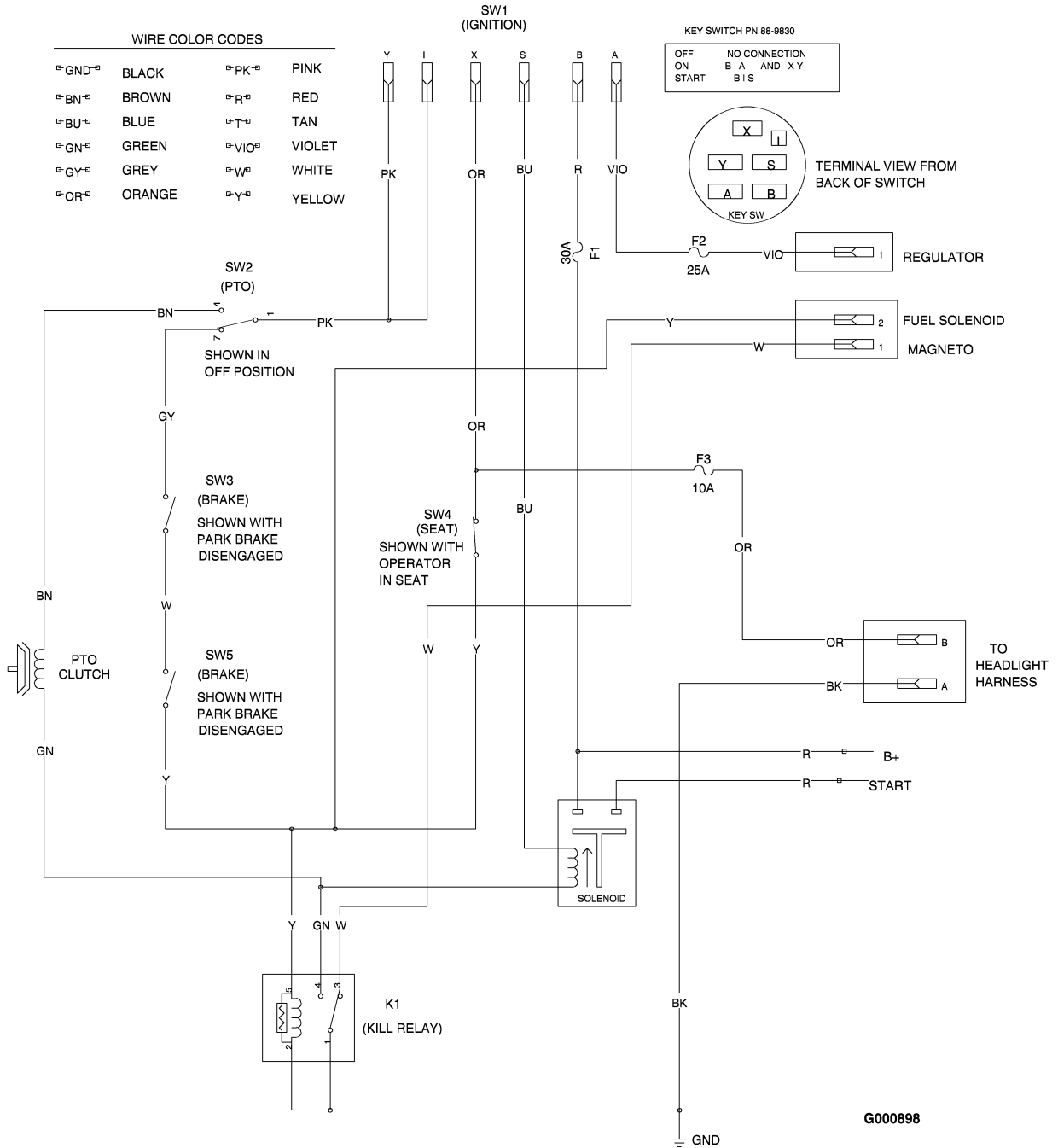

Electrical Schematic (Rev. A)

Notes:

Notes:



Count on it.