

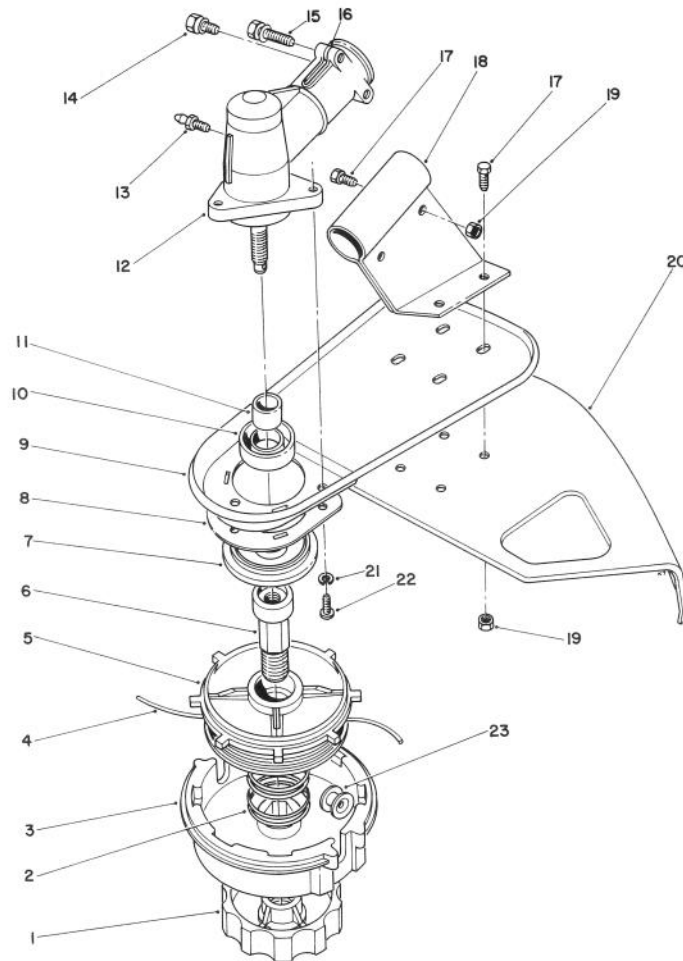

MODEL NO. 51644-600001 &amp; Up

**PARTS  
CATALOG**
**TC 4000 GAS TRIMMER**

**TRIMMER HEAD & GEAR BOX ASSEMBLY**

Ref. No.	Part No.	Description	No. Used
1	57-5580	Knob — L.H.	1
2	57-5620	Spring	1
3	57-5600	Housing — Spool	1
4	43-5000	.080 Line (38 Ft.) (Optional)	1
*	46-2710	.080 Line (1 Lb.-400 Ft.) (Optional)	1
*	41-6820	.095 Line (1 Lb.-285 Ft.) (Optional)	1
*	46-2730	.105 Line (1 Lb.-235 Ft.) (Optional)	1
*	52-5070	.105 Line (20 Ft.) (Optional)	1
*	46-2740	.130 Line (3 Lb.-450 Ft.) (Optional)	1
5	57-5590	Spool — Inner	1
6	57-5610	Shaft	1
7	48-2080	Dust Cap	1
8	57-5540	Guard — Grass Wrap	1
9	47-2800	Support — Shield	1

Ref. No.	Part No.	Description	No. Used
10	48-2090	Seal — Oil	1
11	48-2100	Sleeve — Spline	1
12	52-5710	Gear Box Assembly (Incl. Ref. #10, 11, & 13-15)	1
13	53-7410	Fitting — Grease	1
14	48-2150	Hex Hd. Machine Screw	1
15	48-2130	Hex Hd. Machine Screw	2
16	48-2140	Washer	2
17	32105-8	Hex Hd. Machine Screw	6
18	47-2760	Bracket — Shield	1
19	3296-2	Locknut	6
20	47-2810	Shield — Grass	1
21	55-8050	Lockwasher	3
22	57-5550	Screw — Guard	3
23	57-5630	Eyelet	2
*	57-5670	Head Assembly (Incl. Ref. #1-6, 23)	1

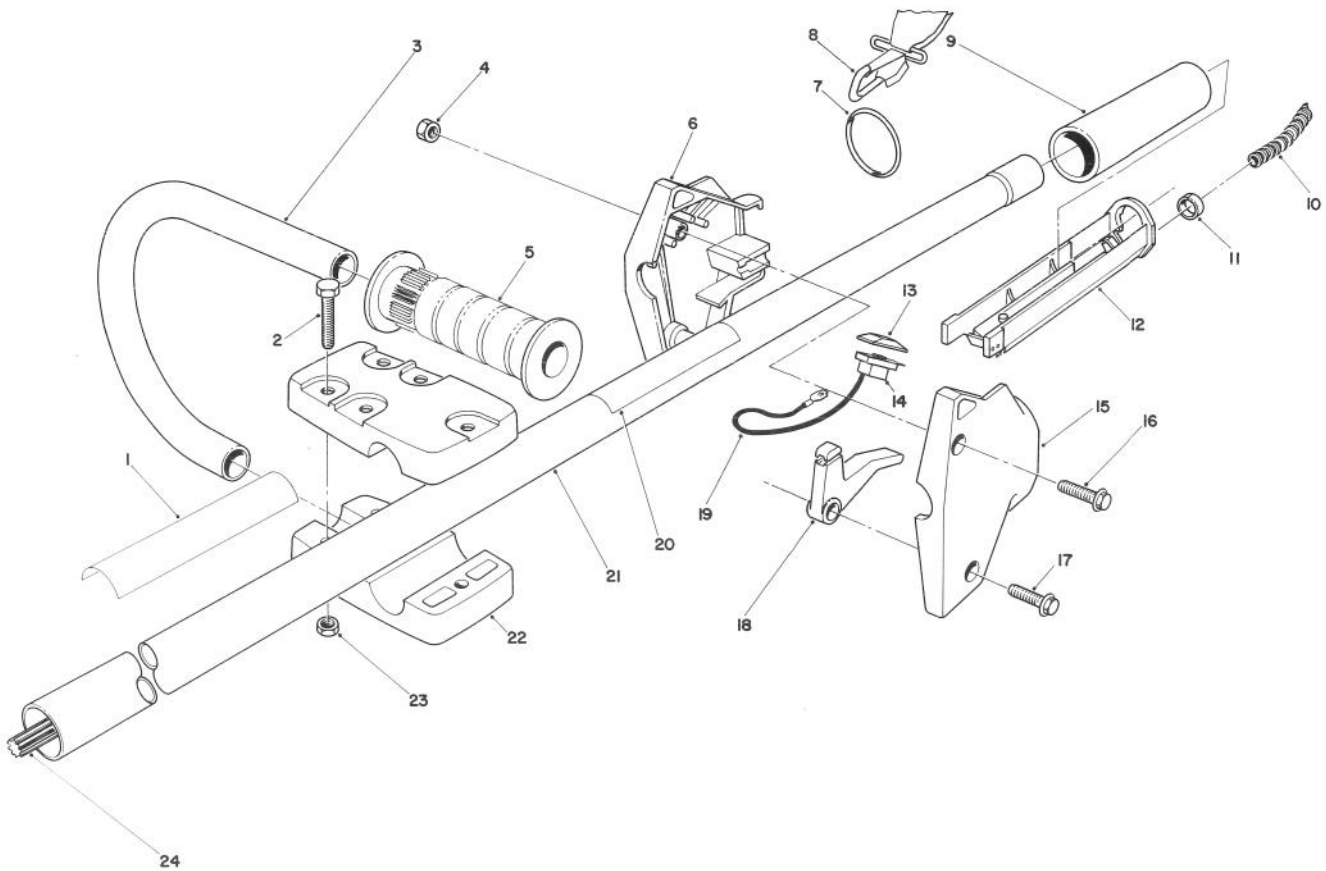
\* Not Illustrated



## HANDLE ASSEMBLY

Ref. No.	Part No.	Description	No. Used
1	53-7170	Decal — TC 4000	1
2	3290-360	Hex Hd. Machine Screw	5
3	44-7530	Tube — Handle	1
4	3296-12	Locknut	2
5	235-24	Grip — Handle	1
6	53-7250	Housing — R.H.	1
7	44-7540	Ring — Harness	1
8	46-2951	Harness — Shoulder	1
9	53-7120	Grip — Rubber	1
10	55-8412	Cover — Cable	1
11	2412-48	Clip	2
12	53-7290	Trough	1

Ref. No.	Part No.	Description	No. Used
13	218-507	Cap — Switch	1
14	42-6000	Switch	1
15	53-7260	Housing — L.H.	1
16	32105-12	Hex Washer Hd. Screw	1
17	32105-13	Hex Washer Hd. Screw	1
18	53-7270	Lever — Throttle	1
19	53-7370	Wire Assembly	1
20	46-9480	Decal — Warning	1
21	53-7501	Tube Assembly	1
22	53-7080	Clamp — Handle	2
23	3296-2	Locknut	5
24	53-7210	Spline Shaft — Drive	1

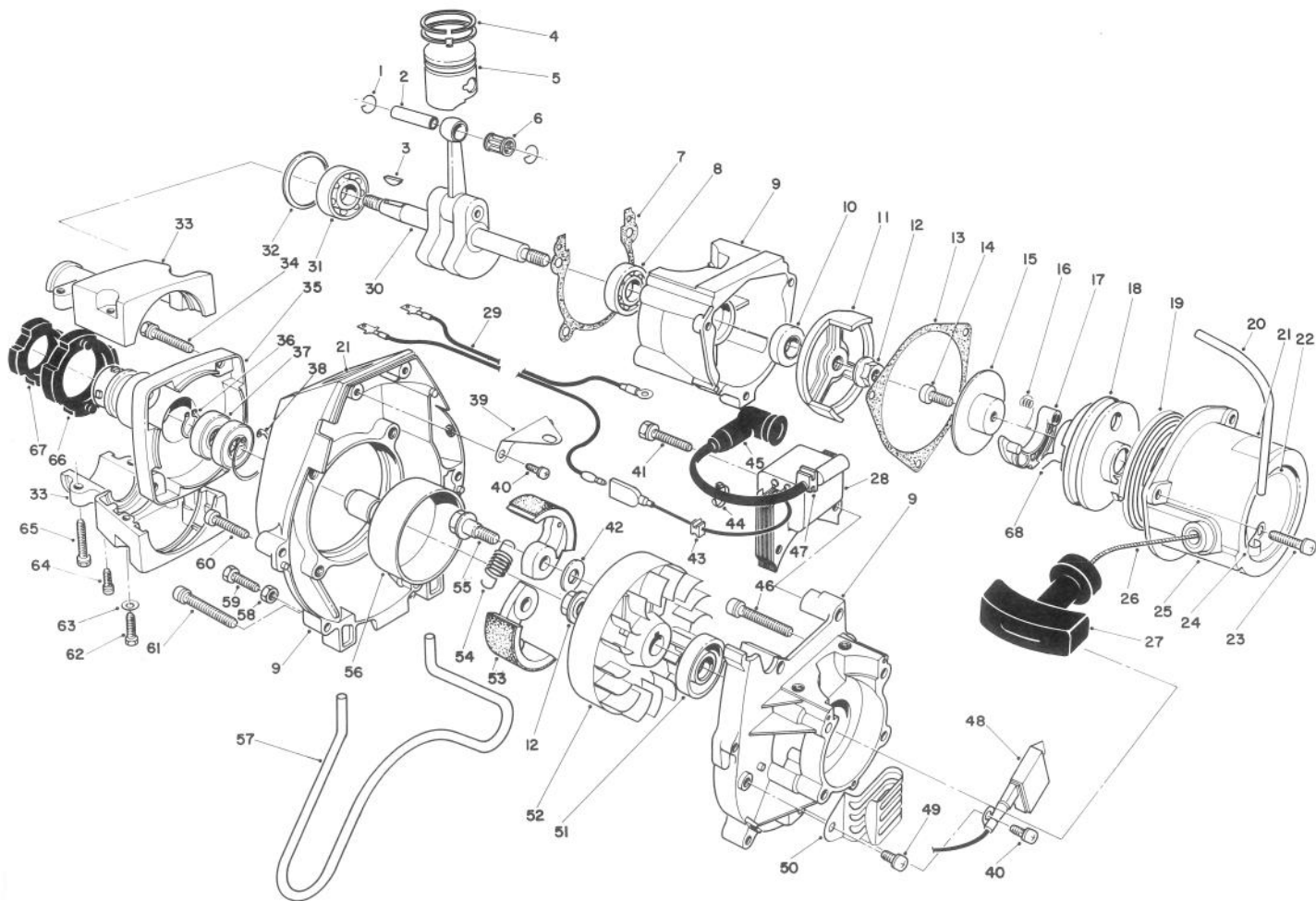

## ENGINE ASSEMBLY

Ref. No.	Part No.	Description	No. Used
1	54-5920	Clip — Piston Pin	2
2	54-5910	Pin — Piston	1
3	54-4660	Key — Woodruff	1
4	54-5940	Ring — Piston	2
5	54-5900	Piston Set (Incl. Ref. #2)	1
6	54-5930	Bearing — Needle	1
7	54-5810	Gasket — Case	1
8	54-4360	Bearing	1
9	54-5660	Crankcase (Incl. Ref. #46 & 59)	1
10	54-4380	Seal — Oil	1
11	54-6290	Pulley — Starter	1
12	54-4670	Nut — Conical	2
13	54-6280	Gasket — Starter	1
14	54-6340	Screw	1
15	54-6350	Plate — Friction	1
16	54-6330	Spring — Return	1
17	54-6360	Ratchet	1
18	54-6310	Reel	1
19	54-6300	Spring — Spiral	1
20	54-6060	Tube — Fuel	1
21	53-7190	Decal — Hot Label	2

Ref. No.	Part No.	Description	No. Used
22	33-8340	Decal — Toro	1
23	54-6260	Screw	1
24	54-5340	Clamp	1
25	54-6270	Recoil Starter (Incl. Ref. #11, 14-19, 26, 27, & 67)	1
26	54-6370	Rope — Starter	1
27	54-5440	Knob — Starter	1
28	54-5960	Coil — Ignition	1
29	54-6510	Lead — Wire	1
30	54-5950	Crankshaft (Incl. Ref. #3, & 6)	1
31	54-5820	Bearing	1
32	54-4490	Snap Ring	1
33	54-6480	Holder	1
34	54-5720	Bolt & Washer	4
35	54-6450	Case — Clutch	1
36	54-5690	Snap Ring	1
37	54-5680	Bearing	2
38	54-5670	Snap Ring	1
39	54-5750	Bracket	1
40	54-4610	Screw & Washer	4
41	54-4790	Bolt & Washer	2

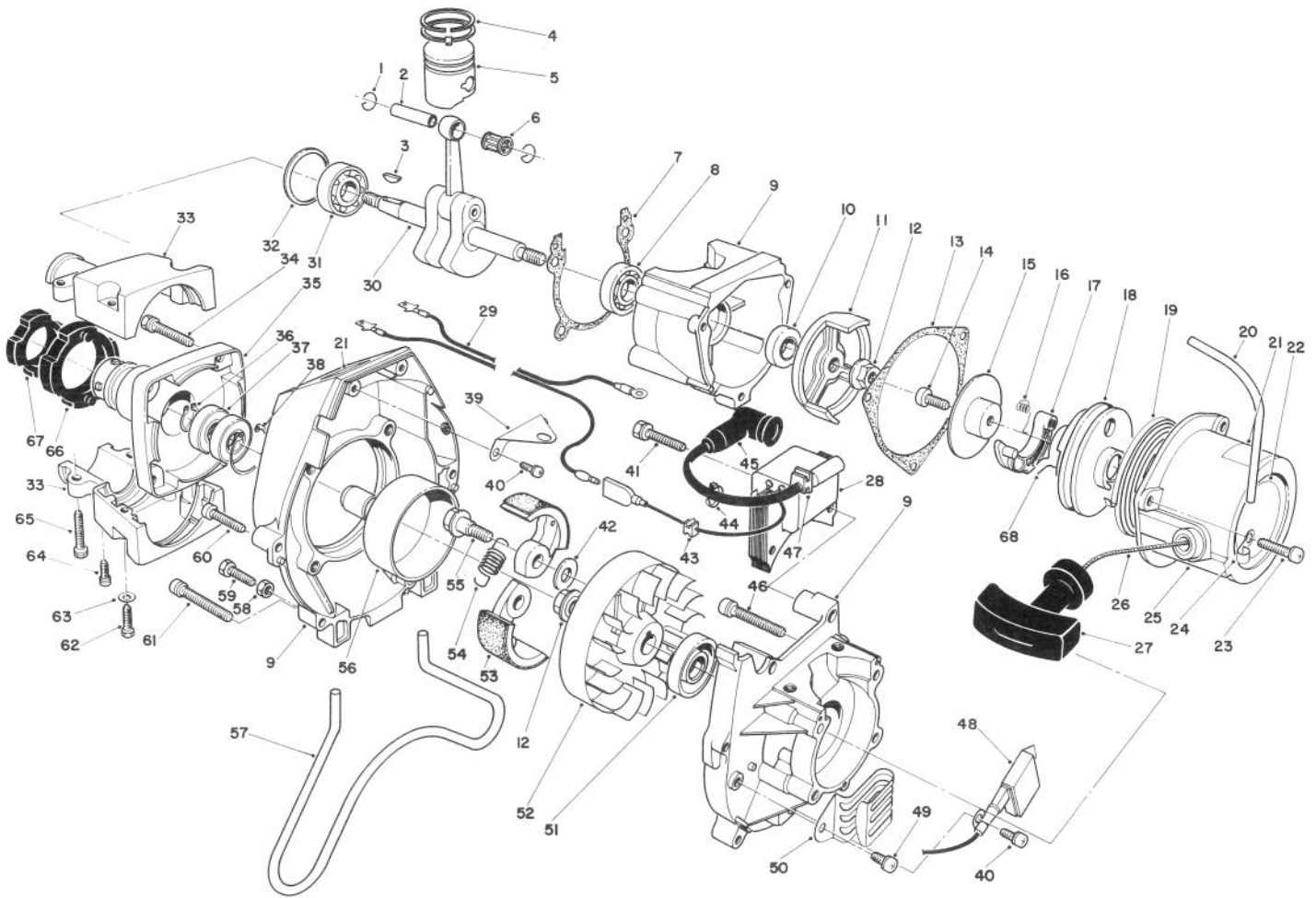

## ENGINE ASSEMBLY (Continued)

Ref. No.	Part No.	Description	No. Used
42	56-6070	Washer	2
43	54-6010	Grommet	1
44	54-5990	Cable Tie	1
45	54-4730	Cap — Plug	1
46	54-5760	Screw & Washer	4
47	54-6000	Grommet	1
48	54-5980	Unit — Transistor	1
49	54-5790	Screw & Washer	1
50	54-5780	Clamp	1
51	54-5800	Seal — Oil	1
52	54-5970	Flywheel	1
53	54-6220	Shoe — Clutch	2
54	54-6230	Spring	1
55	56-6060	Bolt — Clutch	2
56	54-6530	Drum — Clutch	1

Ref. No.	Part No.	Description	No. Used
57	53-7130	Guard — Tank	1
58	54-5840	Nut	2
59	54-5830	Bolt	2
60	54-5770	Screw	3
61	54-4330	Screw	1
62	54-6500	Bolt	2
63	54-6490	Washer — Spring	2
64	54-5730	Screw & Washer	1
65	54-5740	Bolt & Washer	2
66	54-6460	Rubber — Cushion	1
67	54-6470	Rubber — Cushion	1
68	54-6320	Spring — Friction	1
*	54-6240	Clutch Assembly (Incl. Ref. #53 & 54)	1

\* Not Illustrated

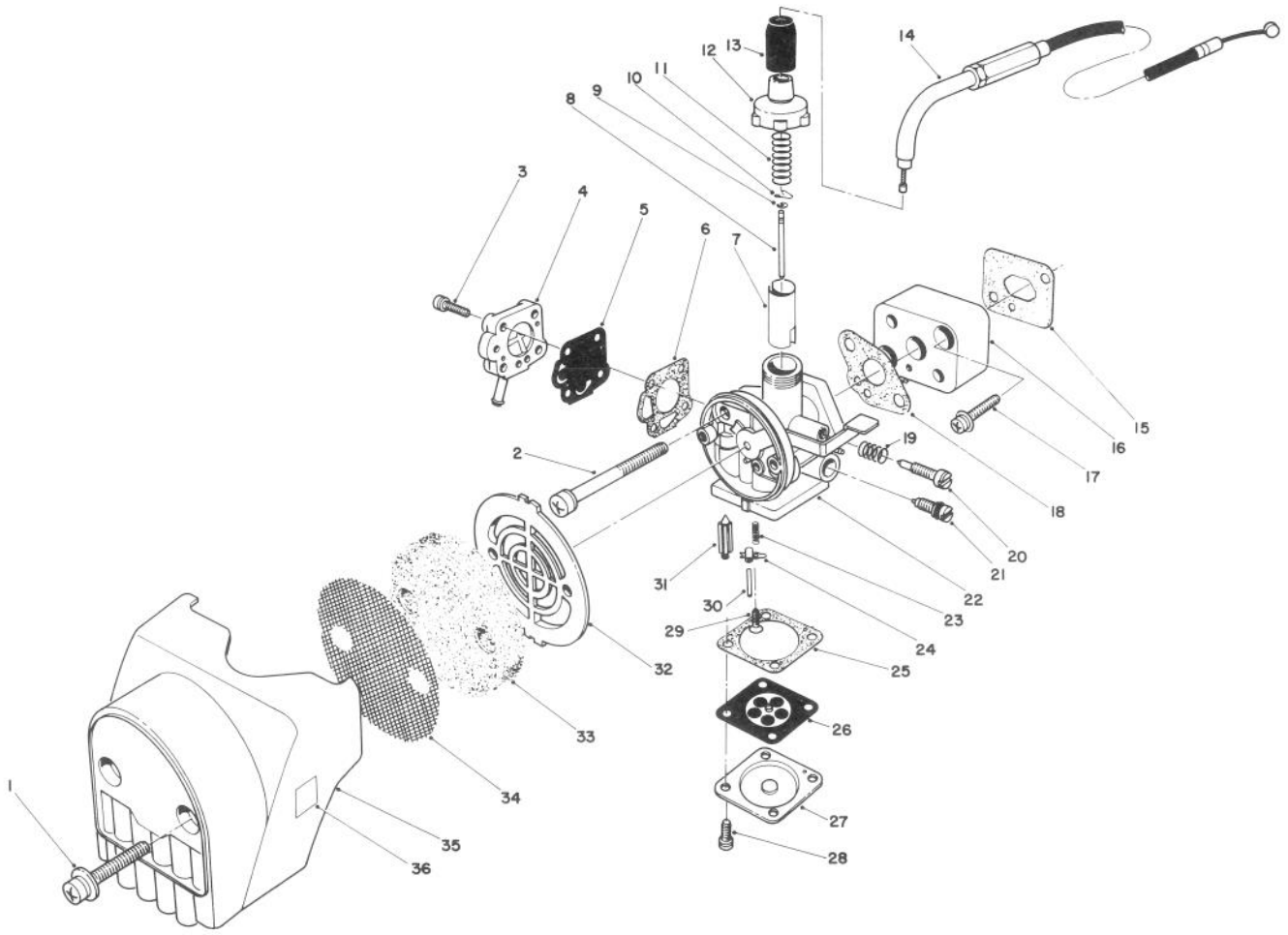

## CARBURETOR & AIR CLEANER ASSEMBLY

Ref. No.	Part No.	Description	No. Used
1	54-5150	Screw & Washer	2
2	54-4870	Screw & Washer	2
3	54-5040	Screw & Washer	4
4	54-6120	Pump Cover Assembly	1
5	54-6110	Diaphragm — Pump	1
6	54-5010	Gasket — Pump Cover	1
7	54-6080	Valve — Throttle	1
8	56-6080	Jet Needle Assembly	1
9	54-4930	Retainer — Spring	1
10	54-7090	Clip — Needle	1
11	54-4920	Spring — Throttle	1
12	54-4910	Cap — Mixing Chamber	1
13	54-4900	Cap — Rubber	1
14	54-6520	Wire — Throttle	1
15	54-6030	Gasket — Insulator	1
16	54-6040	Insulator	1
17	54-6050	Screw & Washer	2
18	54-4850	Gasket — Carburetor	1
19	54-4960	Spring — Adjusting Screw	1
20	54-6090	Screw — Adjusting	1

Ref. No.	Part No.	Description	No. Used
21	54-6100	Main Jet Needle Assembly	1
22	54-6070	Carburetor Assembly (Incl. Ref. #3-13, 19-21, & 23-31)	1
23	54-4990	Spring — Inlet Valve	1
24	54-5060	Arm — Float	1
25	54-5000	Gasket — Main Diaphragm	1
26	54-6130	Main Diaphragm Assembly	1
27	54-5100	Cover — Main Diaphragm	1
28	54-5110	Screw & Washer	4
29	54-5080	Screw — Float Pin	1
30	54-5070	Pin — Float	1
31	54-5050	Valve — Float	1
32	54-5200	Grid	1
33	54-5190	Element	1
34	54-5180	Screen	1
35	54-5160	Cover — Air Cleaner	1
36	54-5170	Label — Choke	1
*	54-5140	Air Cleaner Complete (Incl. Ref. #32-36)	1

\* Not Illustrated

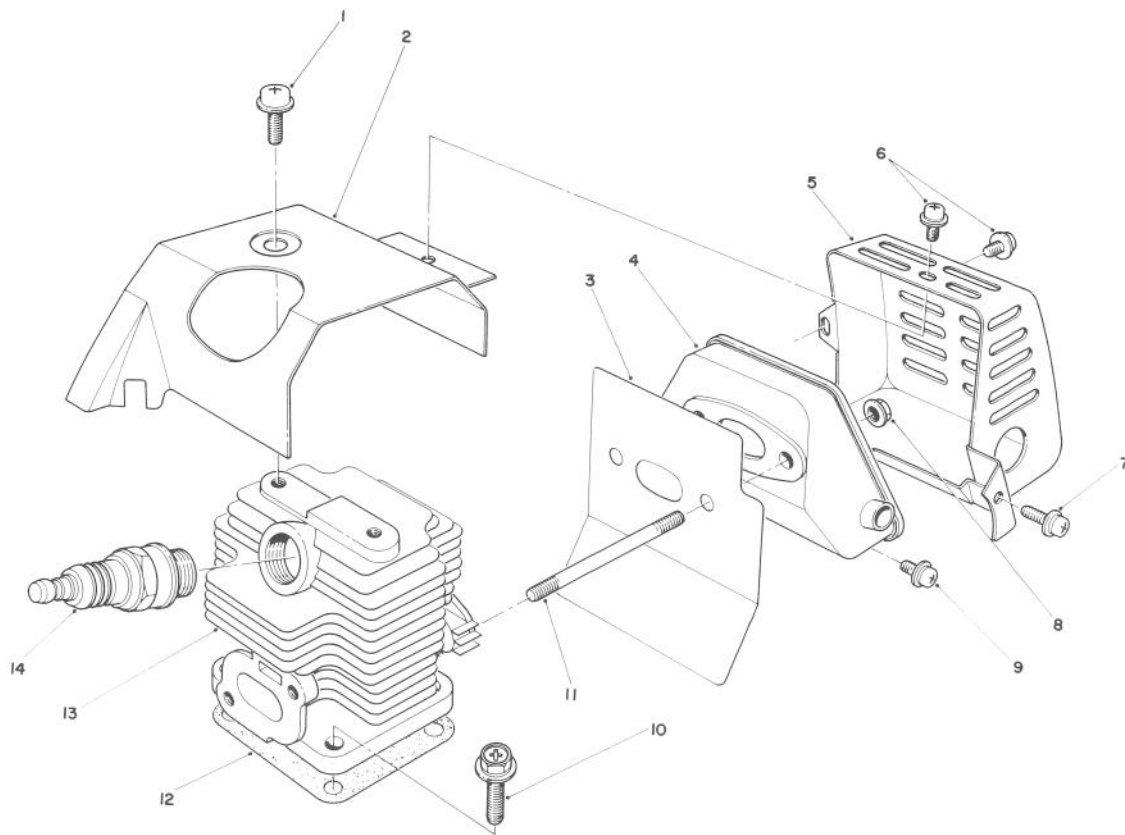

## CYLINDER & MUFFLER ASSEMBLY

Ref. No.	Part No.	Description	No. Used
1	54-5850	Screw & Washer	1
2	54-5860	Cover — Cylinder	1
3	54-6190	Gasket — Muffler	1
4	54-6180	Muffler	1
5	54-6160	Cover — Muffler	1
6	54-6150	Screw & Washer	2
7	54-6210	Screw & Washer	1
8	54-6170	Flange Nut	2

Ref. No.	Part No.	Description	No. Used
9	54-6200	Screw & Washer	1
10	54-4790	Bolt & Washer	4
11	54-5880	Bolt — Stud	2
12	54-5890	Gasket — Cylinder	1
13	54-5870	Cylinder (Incl. Ref. #11)	1
14	45-0320	Spark Plug	1
*	52-5090	Spark Arrestor Muffler (Optional)	1

\* Not Illustrated

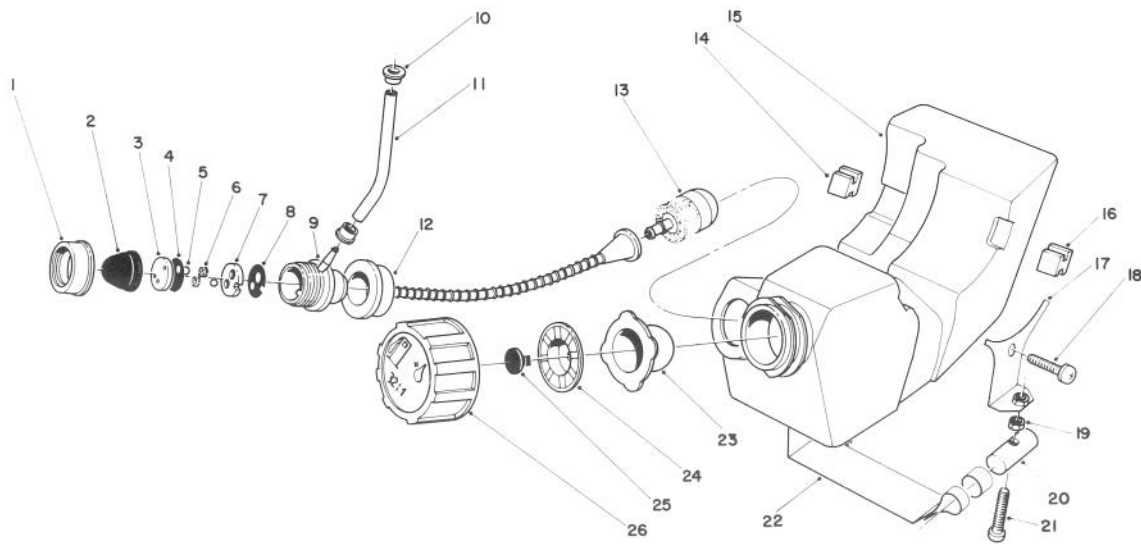

## FUEL TANK ASSEMBLY

Ref. No.	Part No.	Description	No. Used
1	54-5510	Cap — Pump	1
2	54-5520	Cap	1
3	54-5530	Seat — Valve	1
4	54-5460	Gasket	1
5	54-5480	Ball	2
6	54-5470	Sponge	2
7	54-5490	Seat — Valve	1
8	54-5500	Gasket	1
9	54-5570	Primer Pump Assembly (Incl. Ref. #1-8)	1
10	54-5550	Clip	2
11	54-6390	Tube — Fuel	1
12	54-5580	Hose — Suction	1
13	54-5540	Filter — Fuel	1
14	55-8130	Pad	2

Ref. No.	Part No.	Description	No. Used
15	54-6410	Fuel Tank Assembly (Incl. Ref. #1-9, 12, 13, 23-26)	1
16	54-6400	Pad	2
17	54-6420	Hanger — Tank	1
18	54-6260	Screw & Washer	1
19	54-5840	Nut	1
20	54-6430	Bar	1
21	54-4330	Screw	1
22	54-6440	Band — Tank	1
23	54-5630	Gasket	1
24	54-5620	Holder	1
25	54-5610	Valve — Breather	1
26	54-5600	Cap — Tank	1
*	54-5590	Tank Cap Assembly (Incl. Ref. #23-26)	1

\* Not Illustrated

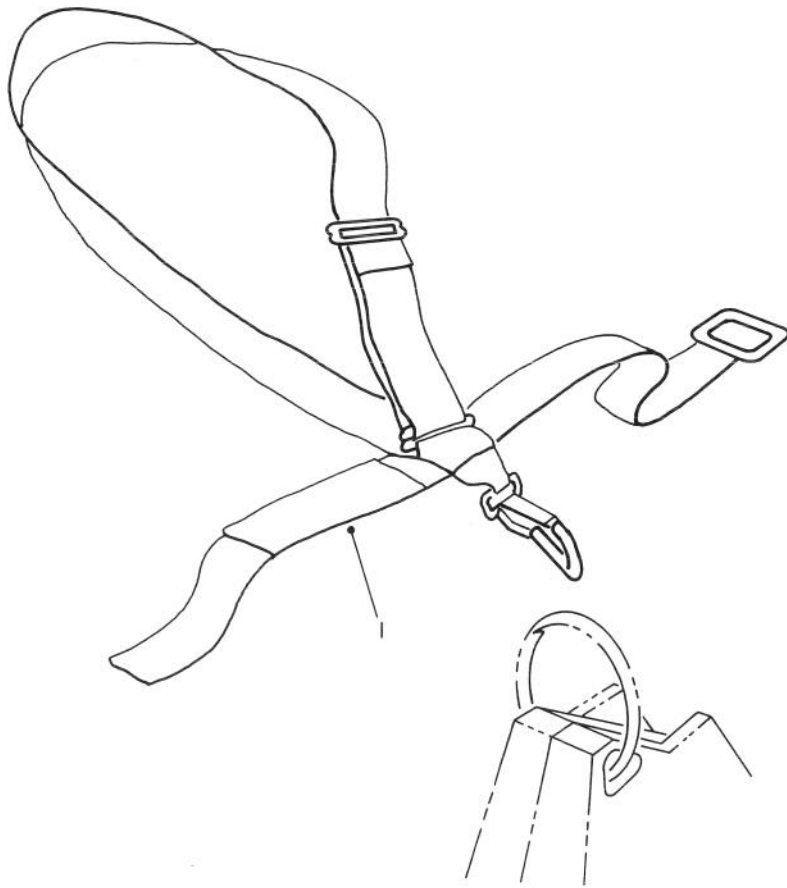

### DELUXE SHOULDER BELT HARNESS (Optional)

Ref. No.	Part No.	Description	No. Used
1	46-2961	Deluxe Harness Assembly	1

Ref. No.	Part No.	Description	No. Used

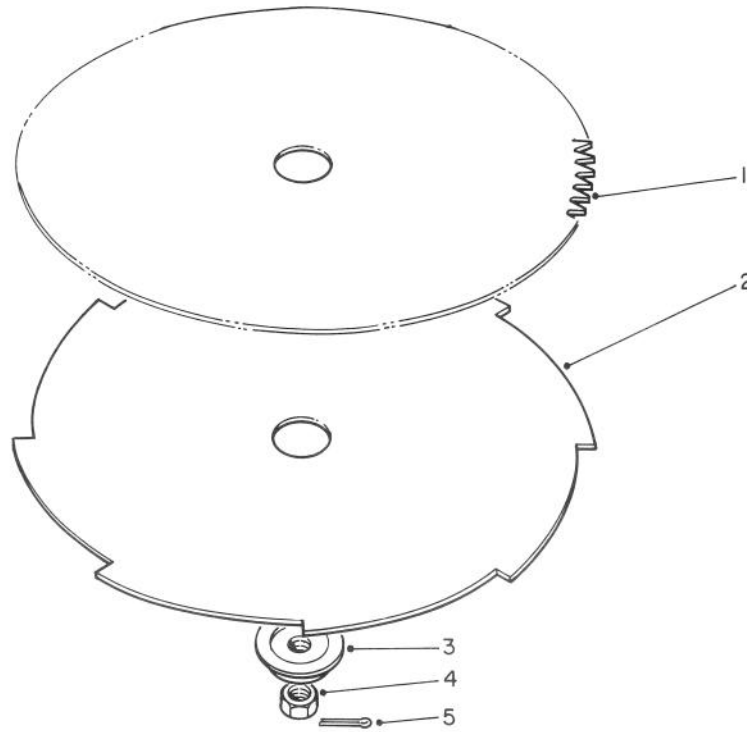

### SAW BLADE AND BRUSH BLADE (Optional)

Ref. No.	Part No.	Description	No. Used	Ref. No.	Part No.	Description	No. Used
1	51-1230	8" Dia. Blade (80 Tooth)	1	5	3272-3	Cotter Pin	1
2	51-1240	8" Dia. Blade (8 Tooth)	1	*	41-4440	Blade Adapter Kit (Incl. Ref. #2-4)	1
3	41-6890	Adapter — Blade	1				
4	41-5410	Nut	1				

\* Not Illustrated

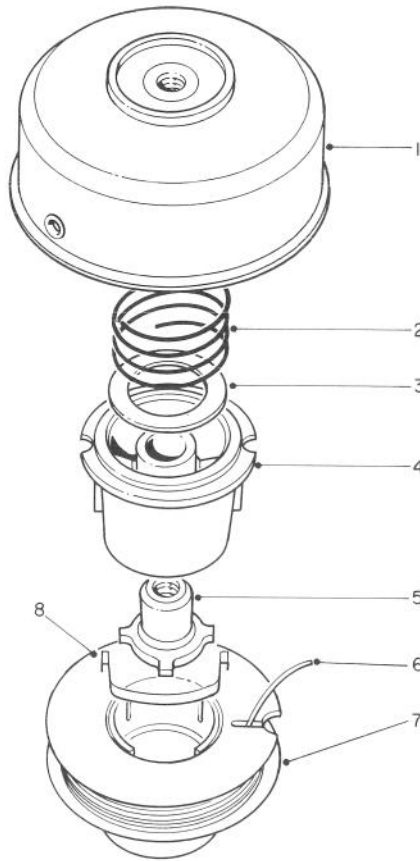

### SINGLE LINE TAP & TRIM HEAD NO. 41-6220 (Optional)

Ref. No.	Part No.	Description	No. Used
1	41-6230	Drum w/Eyelet	1
2	33-6460	Spring	1
3	3256-42	Washer	1
4	33-6230	Spool Core	1
5	33-6470	Driver	1

Ref. No.	Part No.	Description	No. Used
6	41-6820	1 Lb. Filament Line Pack (.095)	1
7	46-2830	Prewound Spool	1
*	29-7380	Empty Spool	1
*	41-6830	3 Lb. Line Bulk (.095)	1
8	33-8940	Saddle Clip	1

\* Not Illustrated

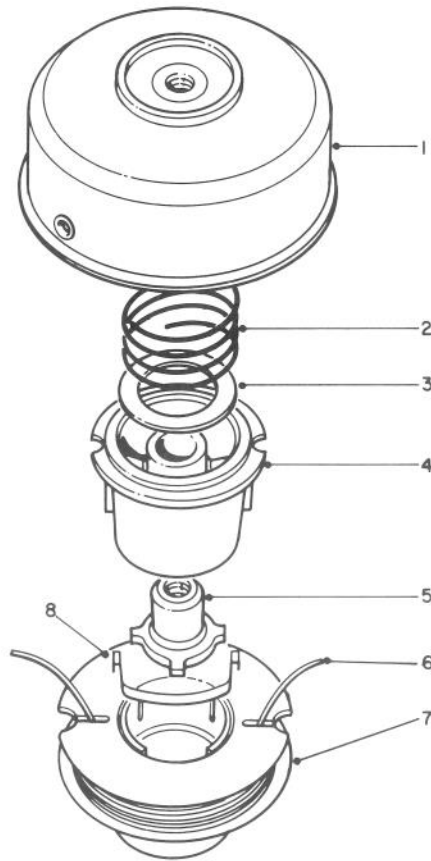

### DUAL LINE TAP & TRIM HEAD NO. 46-2800 (Optional)

Ref. No.	Part No.	Description	No. Used
1	46-2650	Drum Assembly w/Eyelet	1
2	33-6460	Spring	1
3	3256-42	Washer	1
4	33-6230	Spool Core	1
5	33-6470	Driver L.H.	1

Ref. No.	Part No.	Description	No. Used
6	43-5000	.080 Filament Line in Coil (38 Ft.)	1
*	46-2710	.080 Filament Line in 1 Lb. Pkg. (400 Ft.)	1
7	46-2820	Prewound Spool	1
8	33-8940	Saddle — Spool Cap	1

\* Not Illustrated

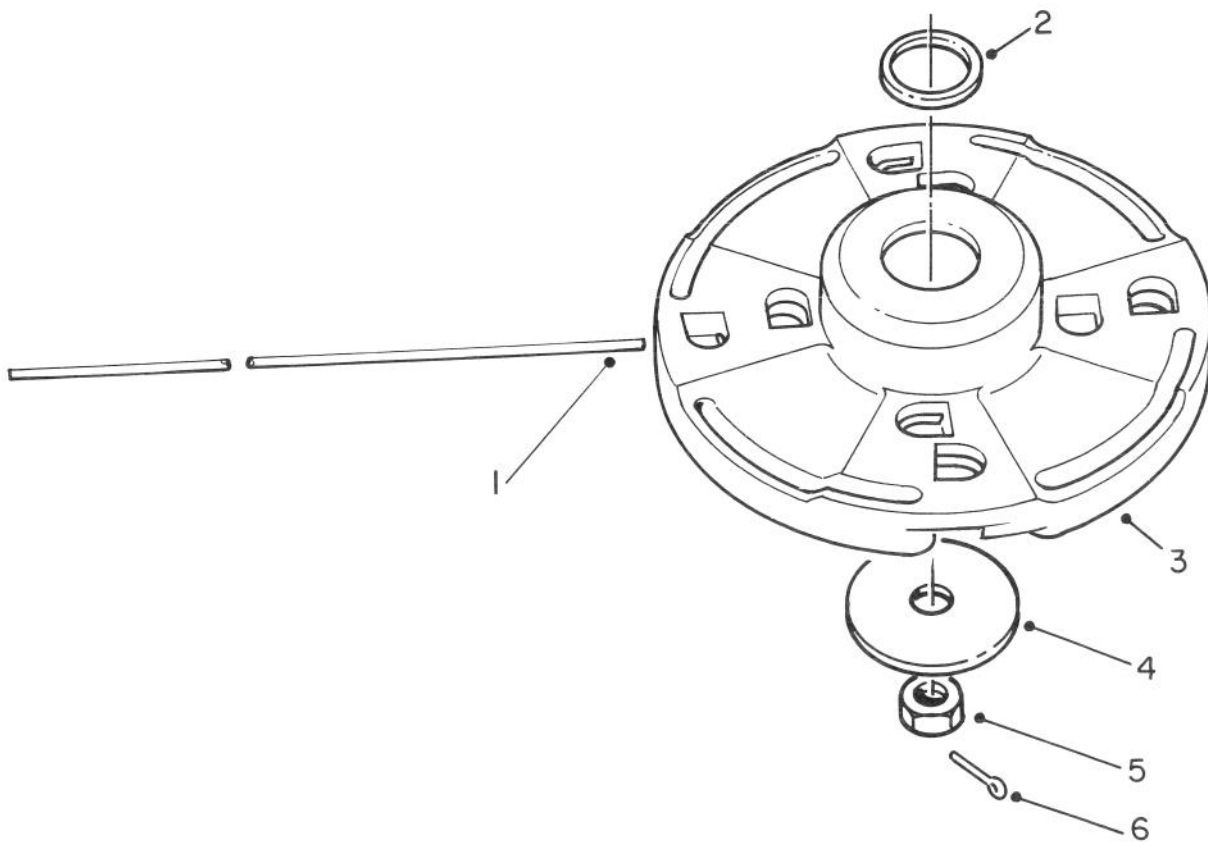

### FIXED LINE HEAD (Optional)

Ref. No.	Part No.	Description	No. Used
1	47-2260	.105 (100 Pcs.) (Optional)	1
*	42-0580	.130 Line (100 Pcs.) (Optional)	1
*	46-2730	.105 Line (1 Lb.-235 Ft.) (Optional)	1
*	46-2740	.130 Line (3 Lb.-450 Ft.) (Optional)	1

Ref. No.	Part No.	Description	No. Used
2		Spacer	1
3	46-2810	Head Assembly (Incl. Ref. #2)	1
4	41-4430	Washer — Plate	1
5	41-5410	Hex Nut	1
6	3272-3	Cotter Pin	1

\* Not Illustrated

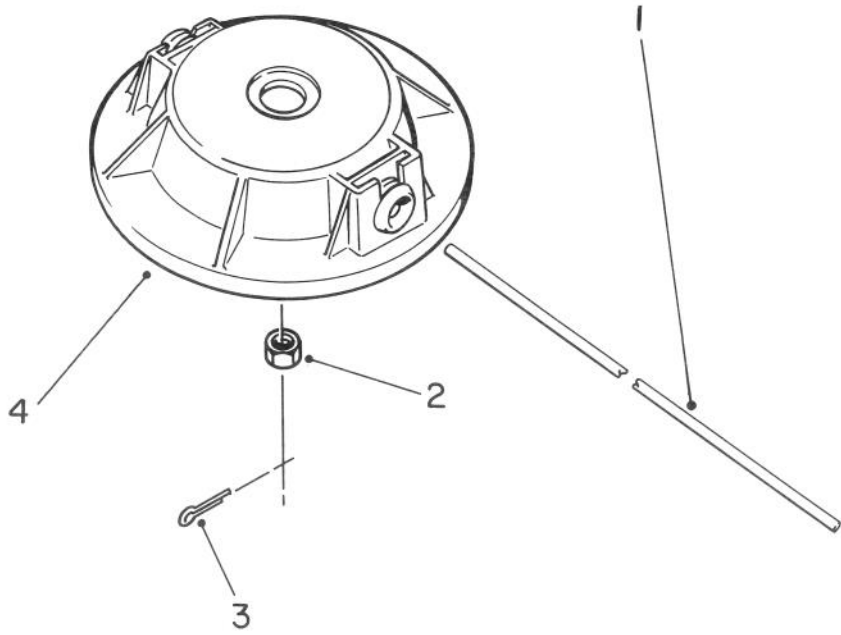

### FIXED LINE HEAD (Optional)

Ref. No.	Part No.	Description	No. Used
1	47-2260	.105 (100 Pcs.) (Optional)	1
*	46-2730	.105 Line (1 Lb.-235 Ft.) (Optional)	1

Ref. No.	Part No.	Description	No. Used
2	41-5410	Hex Nut	1
3	3272-1	Cotter Pin	1
4	51-2760	Head Assembly	1

\* Not Illustrated

## PRODUCT CHANGES

In an effort to make improvements available to TORO owners as quickly as possible, minor changes are incorporated into Toro's products from time to time that do not become immediately shown in the Parts Catalog. If such a change apparently has been made in your unit, which is not reflected in your manual, see your TORO Distributor or his Authorized TORO Service Dealer for information and part numbers.

## IDENTIFICATION AND ORDERING

### MODEL AND SERIAL NUMBERS

The Trimmer has two identification numbers: a model number and a serial number. The two numbers are stamped on a decal which is located in front of throttle lever on bottom side of drive shaft tube. In any correspondence concerning the trimmer, supply model and serial numbers to assure that correct information and replacement parts are obtained.

To order replacement parts from an Authorized TORO Service Dealer, supply the following information:

1. Model and serial numbers of the trimmer.
2. Part number, description, and quantity of part(s) desired.

**Note:** Do not order by reference number if a parts catalog is being used; use the PART NUMBER.

## The Toro Promise

### TORO GAS TRIMMER/WEEDER A TWO YEAR LIMITED WARRANTY

*The Toro Company promises to repair your TORO Product if defective in materials or workmanship. The following time periods from the date of purchase apply:*

Residential Product . . . . . 2 Years  
Residential Products Used Commercially . . . . . 90 Days

*The costs of parts and labor are included, but the customer pays the transportation costs. Just return any residential product to an Authorized TORO Service Dealer or TORO Distributor.*

Should you feel your TORO Product is defective and wish to rely on The Toro Promise, the following procedure is recommended:

1. Contact any Authorized TORO Service Dealer, TORO Master Service Dealer, or TORO Distributor (the Yellow Pages of your telephone directory is a good reference source).
2. He will either instruct you to return the product to him or recommend another Authorized TORO Service outlet which might be more convenient.
3. Bring the product along with your original sales slip, or other evidence of purchase date, to the service dealer.
4. The servicing dealer will inspect the unit, advise you whether the product is defective and, if so, make all repairs necessary to correct the defect without extra charge to you.

If for any reason you are dissatisfied with the dealer's analysis of the defect or the service performed, you may contact us.

Write:  
TORO Consumer Service Department  
8111 Lyndale Avenue South  
Minneapolis, Minnesota 55420

The above remedy of product defects through repair by an Authorized TORO Service Dealer is the purchaser's sole remedy for any defect.

**THERE IS NO OTHER EXPRESS WARRANTY. ALL IMPLIED WARRANTIES OF MERCHANTABILITY AND**

**FITNESS FOR USE ARE LIMITED TO THE DURATION OF THE EXPRESS WARRANTY.**

Some states do not allow limitations on how long an implied warranty lasts, so the above limitation may not apply to you.

This warranty applies only to parts or components which are defective and does not cover repairs necessary due to normal wear, misuse, accidents, or lack of proper maintenance. Regular, routine maintenance of the unit to keep it in proper operating condition is the responsibility of the owner.

All warranty repairs reimbursable under The Toro Promise must be performed by an Authorized TORO Service Dealer using Toro approved replacement parts.

Repairs or attempted repairs by anyone other than an Authorized TORO Service Account are not reimbursable under The Toro Promise. In addition, these unauthorized repair attempts may result in additional malfunctions, the correction of which is not covered by warranty.

**THE TORO COMPANY IS NOT LIABLE FOR INDIRECT, INCIDENTAL OR CONSEQUENTIAL DAMAGES IN CONNECTION WITH THE USE OF THE PRODUCT INCLUDING ANY COST OR EXPENSE OF PROVIDING SUBSTITUTE EQUIPMENT OR SERVICE DURING PERIODS OF MALFUNCTION OR NON-USE.**

Some states do not allow the exclusion or limitation of incidental or consequential damages, so the above limitation or exclusion may not apply to you.

This warranty gives you specific legal rights, and you may also have other rights which vary from state to state.

## COUNTRIES OTHER THAN THE UNITED STATES OR CANADA

Customers who have purchased TORO products exported from the United States or Canada should contact their TORO Distributor (Dealer) to obtain guarantee policies for your country, province or state. If for any reason

you are dissatisfied with your Distributor's service or have difficulty obtaining guarantee information, contact the TORO importer. If all other remedies fail, you may contact us at The Toro Company.



