



## 21in Heavy-Duty Recycler<sup>®</sup>/Rear Bagger Lawnmower

Model No. 22177 - 24000001 and up.

### Parts Catalog

---

#### **Ordering Replacement Parts**

To order replacement parts, please supply the part number, the quantity, and the description of each part desired.

#### **Understanding Reference Numbers**

Each Identified part in an illustration has a reference number. The reference number for a part also appears in the parts list, along with other information about the part.

This catalog uses two special reference number formats, one to indicate parts in a service assembly and another to indicate the quantity of a given part in an illustration.

#### **Service Assembly Reference Numbers**

Parts in service assemblies have reference numbers in the form a:b. The a represents the reference number of the entire service assembly and the b represents a sequential number unique to each part within the service assembly.

For example, a wheel assembly might be identified by reference number 6, the tire by 6:1, the valve by 6:2, and the wheel by 6:3. When you order the assembly identified by reference number 6, you receive all parts identified by reference numbers 6:1, 6:2, and 6:3. However, you may also order any part individually. Reference numbers of this type appear in illustrations and in part lists.

#### **Reference Numbers Indicating Quantity**

In an illustration, if a reference number indicates more than one part, the reference number has the form nX y. The n represents the quantity of the part, the X is the multiplication symbol, and the y represents the reference number.

For example, in an illustration, the reference number 2X 37 means that two of the parts identified by reference number 37 are indicated.

# Contents

Description	Page	Description	Page
Deck, Chute and Wheel Assembly	..... 3	Cylinder and Crankcase Assembly	..... 15
Housing Assembly No. 98-7146	..... 5	Piston and Crankshaft Assembly	..... 16
Front Wheel Assembly	..... 6	Valve and Camshaft Assembly	..... 17
Gear Case Assembly No. 74-1861	..... 7	Lubrication Equipment Assembly	..... 18
Engine and Blade Assembly	..... 8	Cooling Equipment Assembly	..... 19
Fuel Line and Tank Assembly	..... 9	Electrical Equipment Assembly	..... 20
Handle Assembly	..... 10	Control Equipment Assembly	..... 21
Control Panel Assembly	..... 11	Carburetor Assembly	..... 22
Rear Drive and Wheel Assembly	..... 12	Air Filter and Muffler Assembly	..... 23
Front and Rear Wheel Assembly	..... 13	Starter Assembly	..... 24
Grass Bag Assembly No. 106-0975	..... 14		

## Part Description Abbreviations

Part descriptions in this catalog may include the following abbreviations.

AR. .... as required	HYD. .... hydraulic
ASM. .... assembly	INC. .... incorporated
CARR. .... carriage	LH. .... left hand
DEG. .... degrees	NI. .... nylon insert
FH. .... flat head	PPH. .... phillips pan head
GA. .... gauge	PTH. .... phillips truss head
HF. .... hex flange	PTO. .... power take off
HH. .... hex head	RH. .... right hand
HHF. .... hex head flange	SFH. .... slotted fillister head
HHFTF. .... hex head flange thread forming	SHH. .... slotted hex head
HJ. .... hex jam	SHWH. .... slotted hex washer head
HLH. .... hex lag head	SPH. .... slotted pan head
HOC. .... height-of-cut	SQH. .... square head
HS. .... hex	SRH. .... slotted round head
HSBH. .... hex socket button head	STD. .... standard
HSFH. .... hex socket flat head	TAP. .... self tapping
HSH. .... hex socket head	TTH. .... torx truss head
HWH. .... hex washer head	WH. .... wing head
HWHTF. .... hex washer head thread forming	

## Footnotes

❶ Not illustrated

❷ Not serviced separately

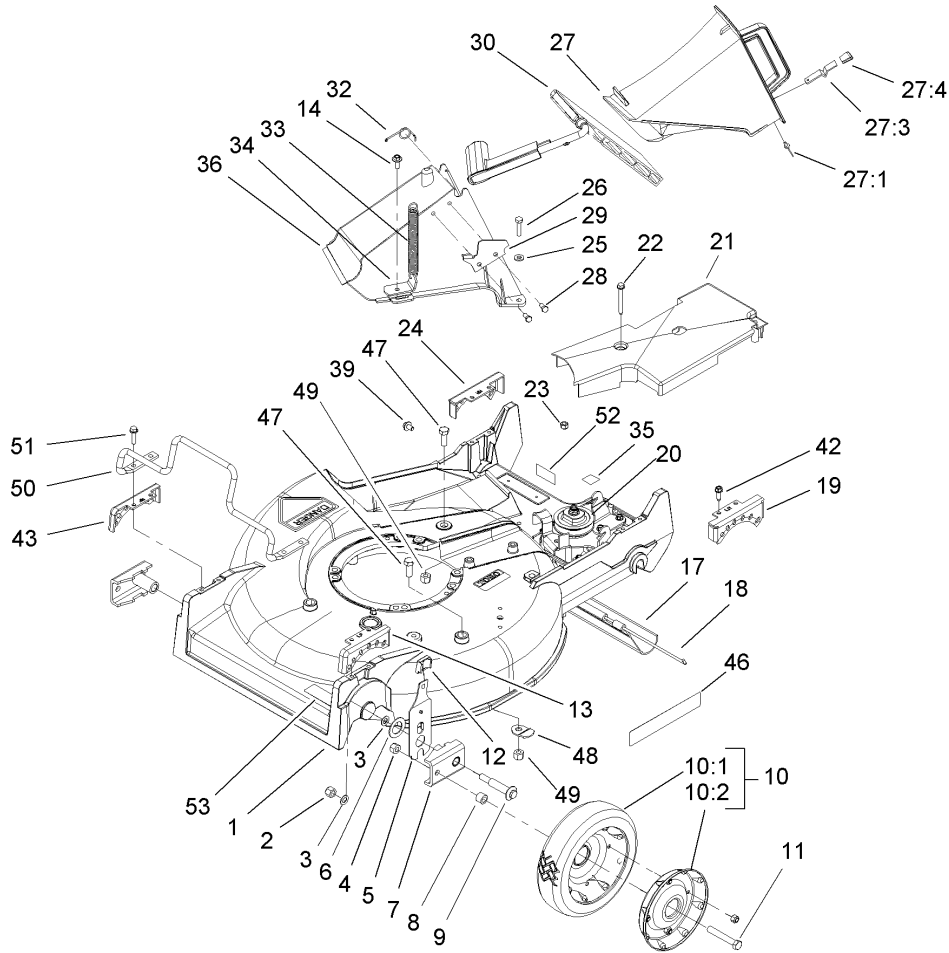

## Deck, Chute and Wheel Assembly

Ref	Part No.	Qty.	Description
1	98-7146	1	Housing
2	3296-6	2	Nut-Lock
3	40-1940	4	Washer
4	32152-2	2	Nut-Lock, Cone
5	66-7560	2	Front Spring Arm ASM
6	257-3	2	Washer-Thrust
7	61-8300	2	Arm-Pivot, Front
8	52-2480	2	Spacer-Wheel
9	27-6232	2	Bolt-Wheel
10	100-2870	2	Wheel And Tire ASM
10:1	53-7740	1	Tire
10:2		1	Wheel ASM
11	323-12	2	Screw-HH
12	25-7740	2	Knob-Arm
13	49-8760	1	Quadrant-Front, LH
14	46-6811	1	Screw-HWH
17	44-0580	1	Shield-Trailing
18	33-3208	1	Rod-Shield
19	49-8740	1	Quadrant-Rear, LH
20	74-1861	1	Gear Case ASM
21	74-1770	1	Cover-Belt
22	37-7260	2	Screw-HH
23	3296-42	2	Nut-Lock, NI
24	49-8750	1	Quadrant-Rear, RH

Ref	Part No.	Qty.	Description
25	3256-22	2	Washer-Flat
26	321-7	2	Screw-HH
27	77-0500	1	Discharge Plug ASM
27:1	3295-35	1	Rivet-Head, Flat
27:3	76-4640	1	Latch-Plug, Discharge
27:4	76-4650	1	Grip-Latch
28	46-8090	2	Screw-Plastite
29	93-3154	1	Latch-Plate
30	93-7351	1	Discharge Door ASM
32	80-3770	1	Retainer-Door
33	76-4660	1	Spring-Door
34	71-9350	1	Bracket-Spring
35	52-2620	1	Label-Grease
36	82-9152	1	Tunnel-Discharge
39	46-6810	1	Screw And Washer ASM
42	49-2040	4	Screw-Tapping
43	49-8770	1	Quadrant-Front, RH
46	106-0689	1	Decal
47	323-6	2	Screw-HH
48	84-8930	2	Shield-Retainer
49	3296-39	2	Nut-Lock, NI
50	99-6722	1	Guard-Engine
51	32144-86	4	Screw-Hwh, Thread Forming
52	92-1779	1	Decal-Warning



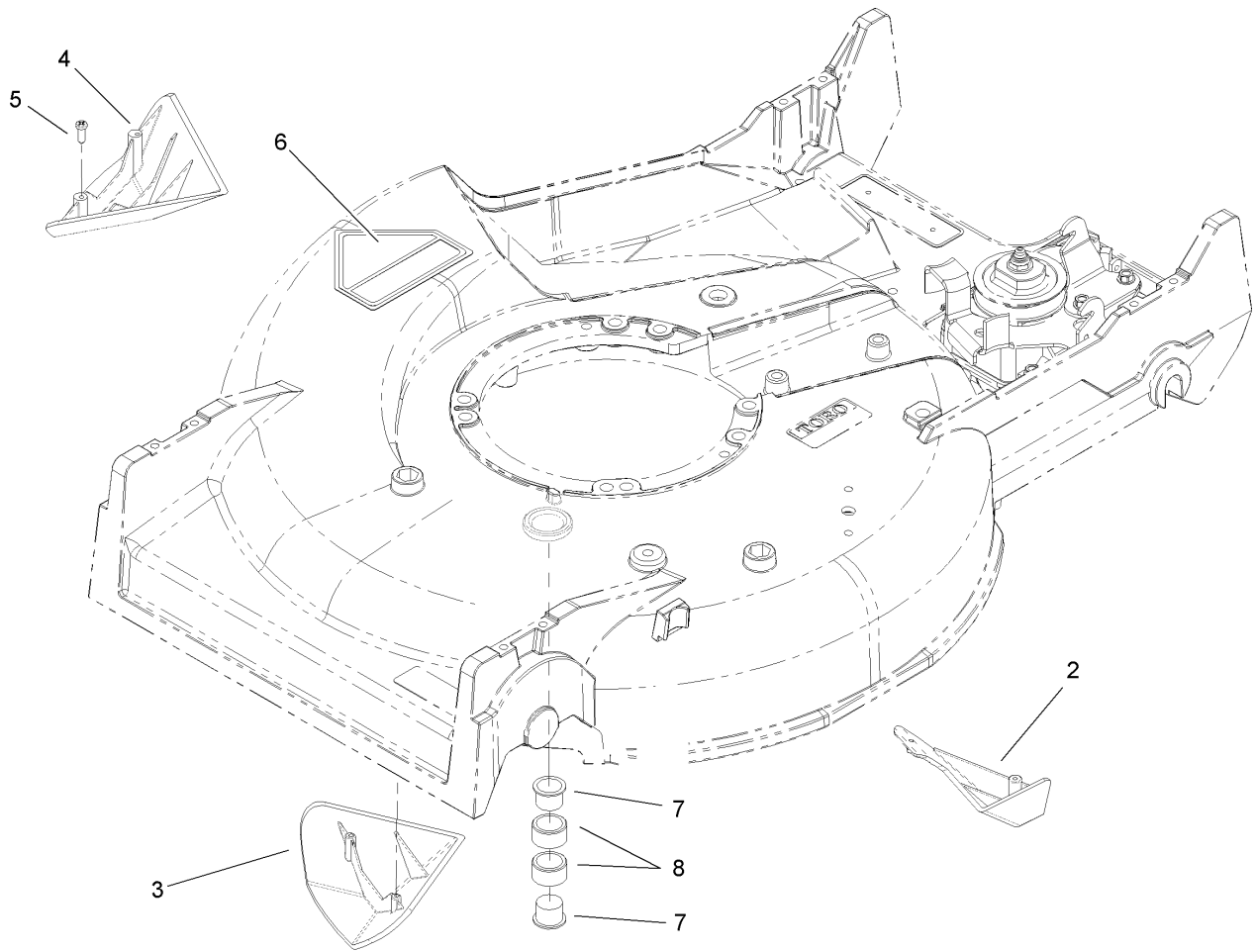

### Housing Assembly No. 98-7146

Ref	Part No.	Qty.	Description				
2	92-1750	1	Kicker-Rear				
3	92-1720	1	Kicker-Front				
4	92-1730	1	Kicker-RH				
5	32144-111	6	Screw-PPH				
6	43-8480	1	Decal-Danger				
7	2410-72	2	Caplug				
8	68-9780	2	Bearing				



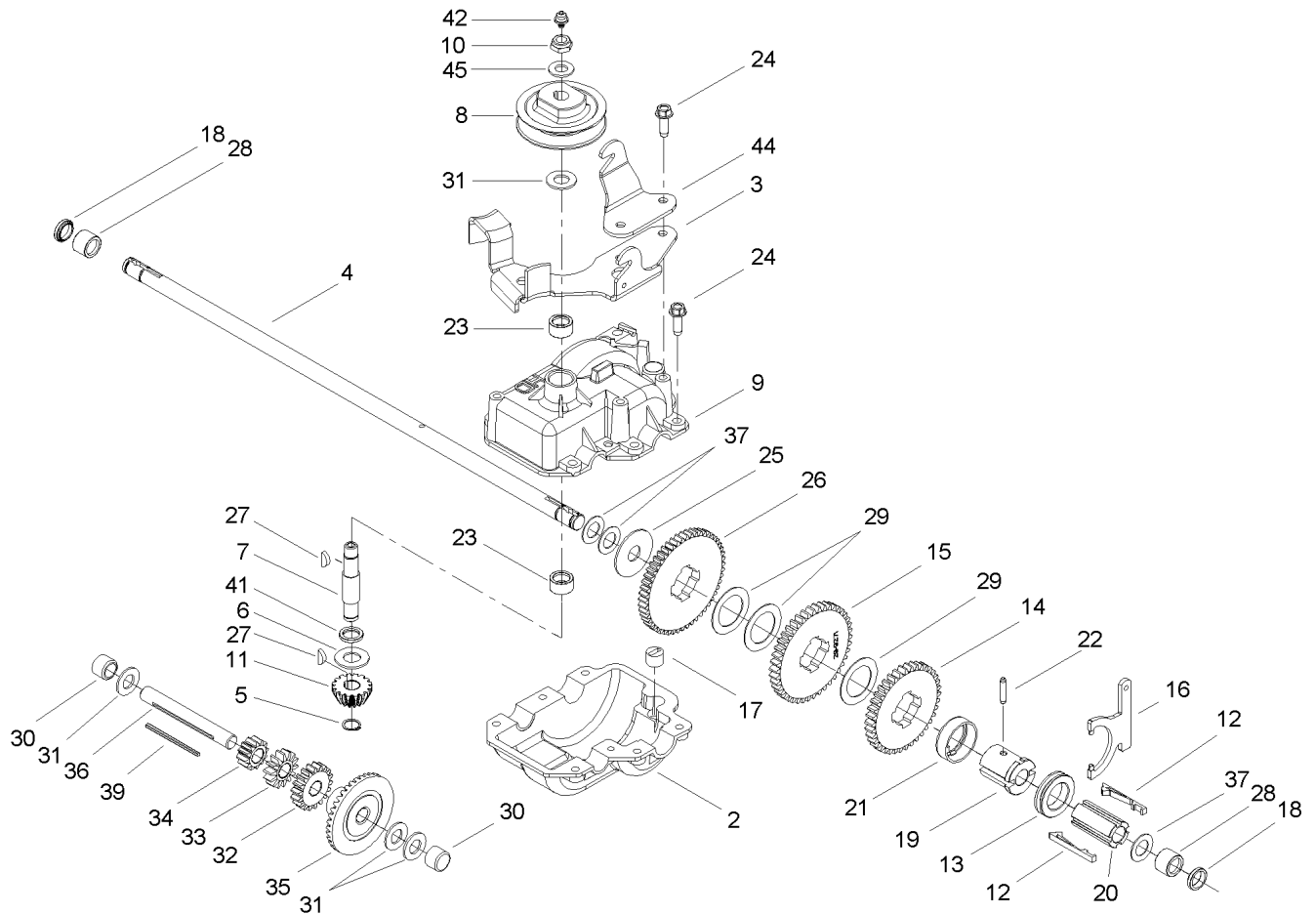

## Gear Case Assembly No. 74-1861

Ref	Part No.	Qty.	Description
2	74-1920	1	Case-Gear, Lower
3	49-8461-03	1	Bracket-Guide, Belt
4	74-1890	1	Shaft-Output
5	32151-57	1	Ring-Retaining
6	47-2910	1	Washer-Thrust
7	68-8190	1	Shaft-Input
8	39-6740	1	Pulley
9	74-1880	1	Case-Gear, Upper
10	3296-5	1	Nut-Lock, NI
11	39-6660	1	Pinion-Bevel
12	29-9330	2	Key-Shift
13	29-9340	1	Collar-Shift
14	42-4740	1	Gear-38 Tooth
15	29-9271	1	Gear-42 Tooth
16	60-8870	1	Yoke-Shift
17	29-9570	1	Bushing-Yoke
18	47-6730	2	Seal-Oil
19	55-8010	1	Sleeve-Gear
20	39-6720	1	Sleeve
21	55-8020	1	Retainer-Key
22	3285-19	1	Pin-Groove
23	47-7270	2	Bearing
24	49-2040	6	Screw-Tapping
25	29-9690	1	Washer

Ref	Part No.	Qty.	Description
26	46-3560	1	Gear
27	3257-1	2	Key-Woodruff
28	48-2060	2	Bearing-Roller
29	36-4770	3	Washer
30	252-103	2	Bearing-Closed
31	36-4792	4	Washer-Thrust
32	39-6650	1	Gear-18t
33	46-3550	1	Gear-14t
34	46-3540	1	Gear-12t
35	74-1760	1	Gear-Bevel
36	53-7950	1	Shaft-Intermediate
37	36-4780	3	Washer
39	39-7842	1	Key
41	47-7260	1	Seal
42	302-63	1	Zerk
44	74-1750-03	1	Brake-Engage, Traction
45	3256-45	1	Washer-Flat

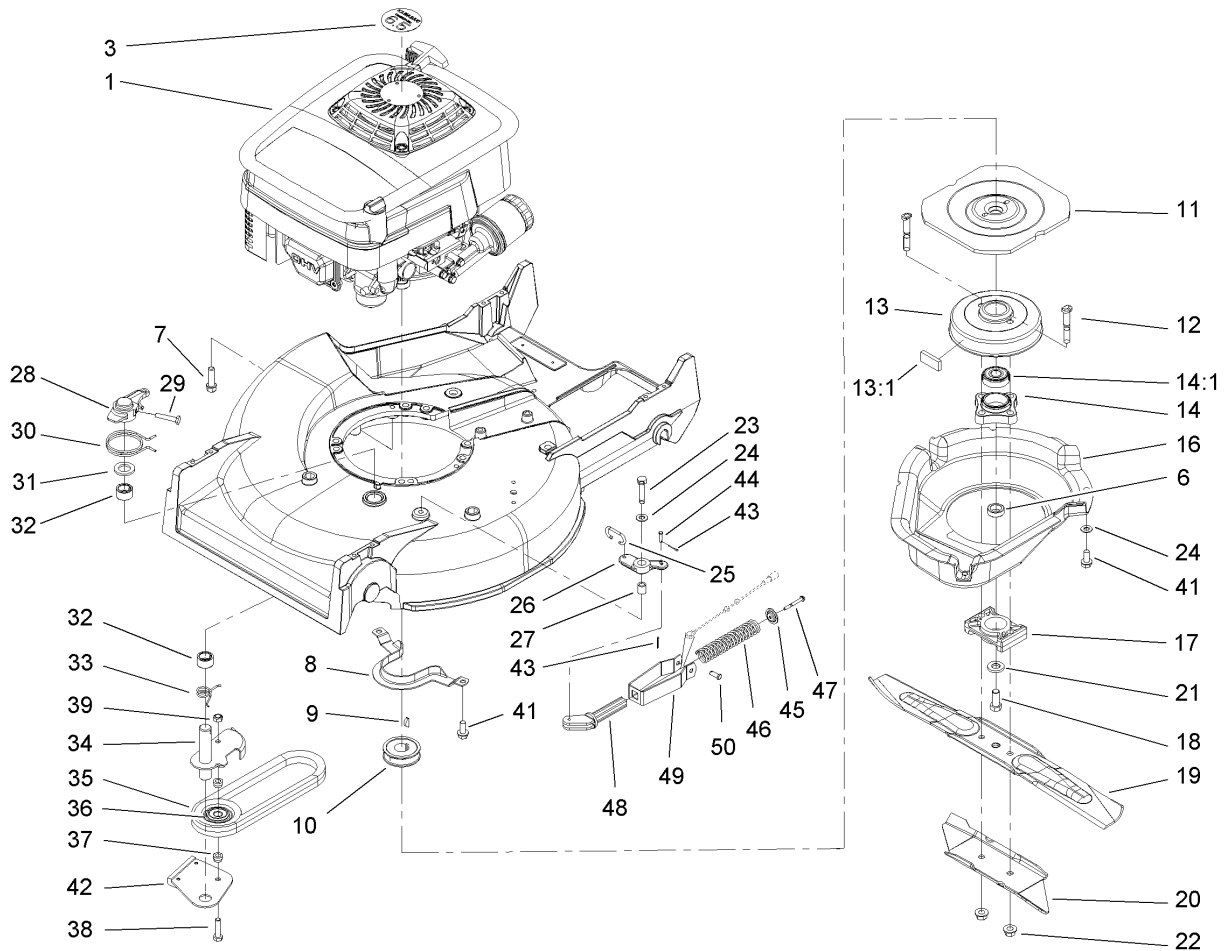

## Engine and Blade Assembly

Ref	Part No.	Qty.	Description
1	106-0845	1	Engine-Kawasaki
3	106-0843	1	Decal-Recoil
6	107-4058	1	Spacer-Output Shaft
7	95-1727	4	Screw-Taptite
8	66-0570-03	1	Bracket-Guide, Belt
9	3257-17	1	Key-Woodruff
10	56-6180	1	Pulley-Driver
11	56-6160-03	1	Flywheel-Bbc
12	42-3190	2	Bolt-Blade
13	94-9431	1	Brake Drum ASM
13:1	52-3480	2	Dampner-Vibration
14	42-6890	1	Hub ASM
14:1	100-1048	2	Bearing-Ball
16	46-5693	1	Shield
17	62-4280	1	Spacer-Blade
18	3212-4	1	Screw-HH
19	14-9419	1	Blade
20	91-2255-03	1	Stiffener-Blade
21	107-4059	1	Cap-Engine
22	54-9190	2	Nut-Lock
23	32104-107	1	Screw-HH
24	3256-23	2	Washer-Flat
25	49-2810	1	Link-Control
26	49-7960	1	Bellcrank

Ref	Part No.	Qty.	Description
27	49-7950	1	Sleeve-Bellcrank
28	49-2820	1	Lever
29	32104-96	1	Screw-HH
30	49-7970	1	Spring-Torsion
31	70-1160	1	Washer
32	68-9780	2	Bearing
33	85-6880	1	Spring-Torsion
34	84-9130	1	Arm-Idler
35	42-0884	1	V-Belt
36	46-5650	1	Pulley-Idler
37	46-5631	2	Hub-Pulley, Idler
38	322-6	1	Screw-HH
39	3296-47	1	Nut-Lock, NI
41	32144-70	3	Screw-HH
42	84-9180	1	Brake Plate ASM
43	3272-1	2	Pin-Cotter
44	84-9050	1	Pin-Spring
45	65-5280	1	Retainer-Spring
46	84-9100	1	Spring
47	46-7040	1	Screw-HWHTF
48	84-8870	1	Guide-Spring
49	84-8880-03	1	Bracket-Spring
50	84-9040	1	Pin-Cable



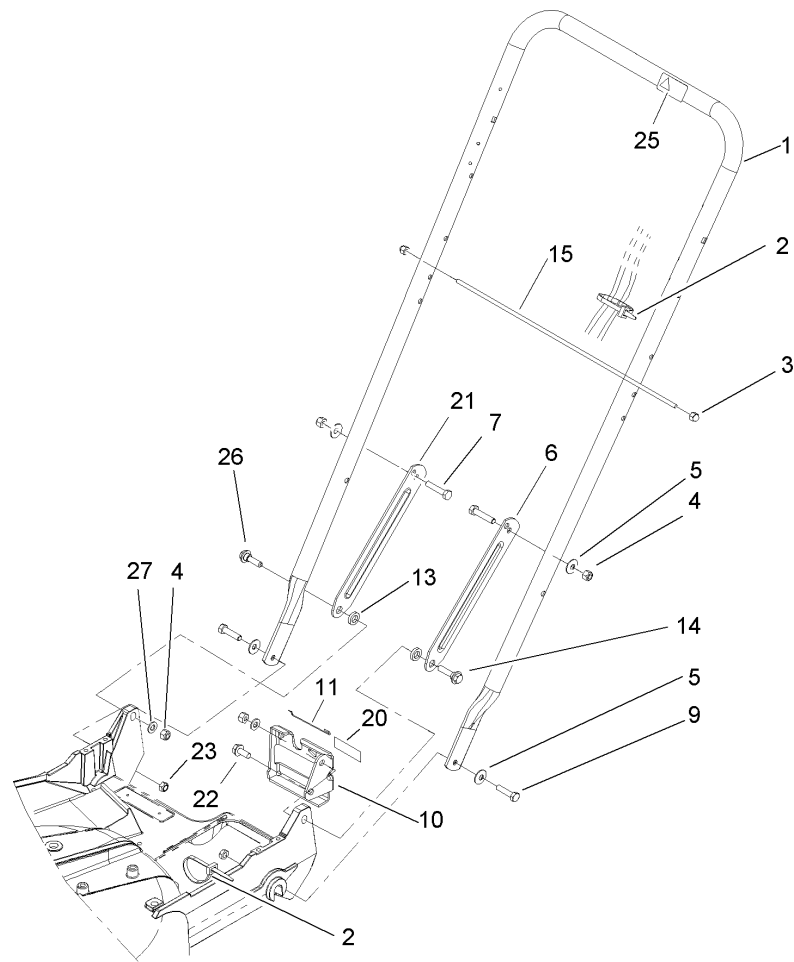

## Handle Assembly

Ref	Part No.	Qty.	Description
1	98-2385-03	1	Handle
2	3290-378	3	Tie-Cable
3	32111-7	2	Nut-Cap
4	3296-29	4	Nut-Lock, NI
5	3290-456	4	Washer-Belleville
6	100-3298-03	1	Latch-Handle, LH
7	322-7	2	Screw-HH
9	322-6	2	Screw-HH
10	74-1741	1	Bracket-Adjustment, Traction
11	46-7030	1	Retainer-Cable
13	3-3287	2	Spacer-Latch, Handle
14	27-7210	1	Screw-Shoulder
15	48-2810	1	Rod-Support, Bag
20	74-1970	1	Decal-Position, Gear
21	100-3297-03	1	Latch-Handle, RH
22	32144-70	1	Screw-HH
23	3296-47	2	Nut-Lock, NI
25	98-4387	1	Decal-Protection, Ear
26	27-7211	1	Screw-Shoulder
27	3256-23	2	Washer-Flat

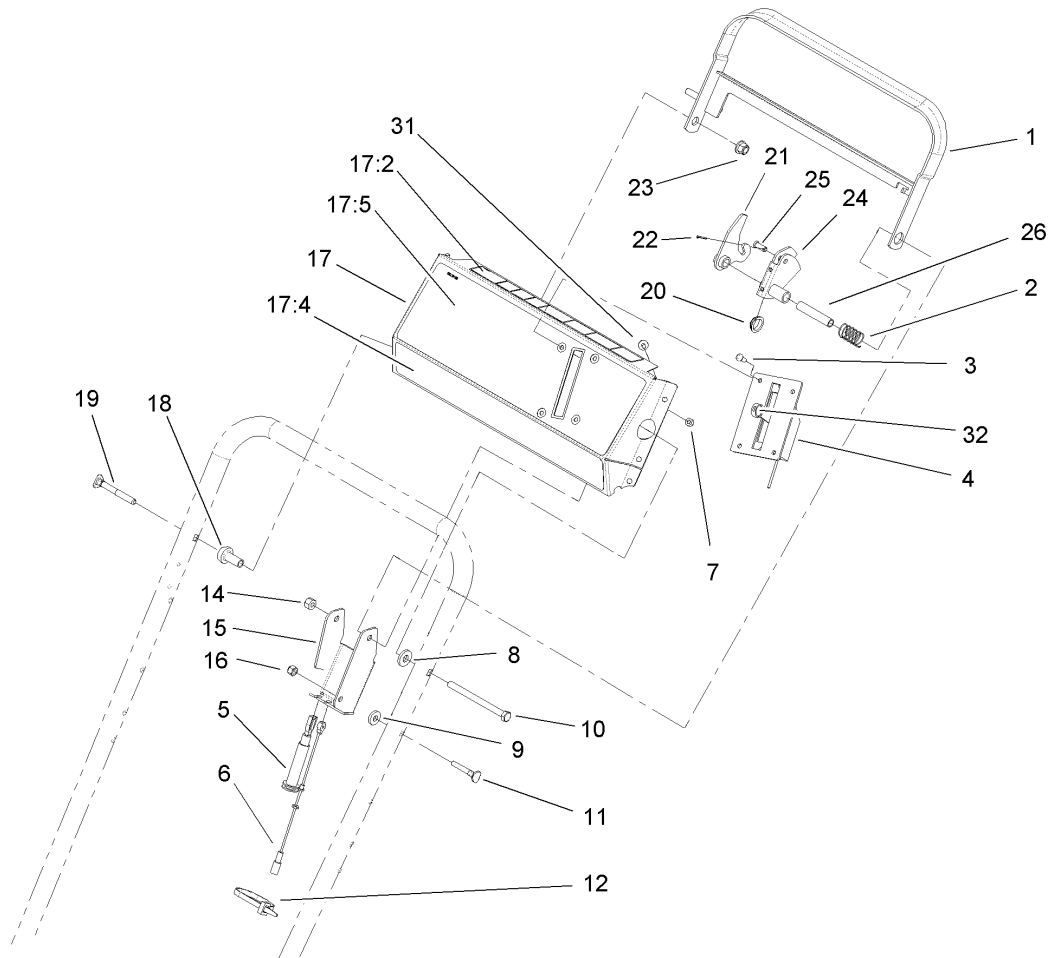
## Control Panel Assembly

Ref	Part No.	Qty.	Description
1	84-8940-03	1	Bar-Control
2	85-6750	1	Spring-Control
3	3250-12	4	Screw-PPH
4	106-0857	1	Control-Throttle
5	84-9120	1	Cable-Traction
6	84-9110	1	Cable-Clutch
7	3296-2	4	Nut-Lock
8	71-9310	1	Spacer
9	71-9320	1	Spacer
10	322-19	1	Screw-HH
11	46-6430	1	Screw-Handle
12	3290-378	1	Tie-Cable
14	3296-29	1	Nut-Lock, NI
15	92-1778-03	1	Bracket-Control
16	3296-42	1	Nut-Lock, NI
17	14-7709	1	Panel ASM W/decals
17:2	63-9060	1	Decal-Panel, Danger
17:4	106-0771	1	Decal-Panel, Proline
17:5	107-4098	1	Decal-Panel, Proline
18	49-1631	1	Spacer-Support
19	17-9427	1	Screw
20	86-9320	1	Bushing-Flange
21	84-9000	1	Lever-Traction
22	3272-1	1	Pin-Cotter

Ref	Part No.	Qty.	Description
23	3296-58	1	Nut-Lock NI
24	84-8990	1	Lever-Bbc
25	84-9040	1	Pin-Cable
26	84-9030	1	Spacer-Bracket, Control
31	32104-76	6	Screw
32	233-35	1	Knob

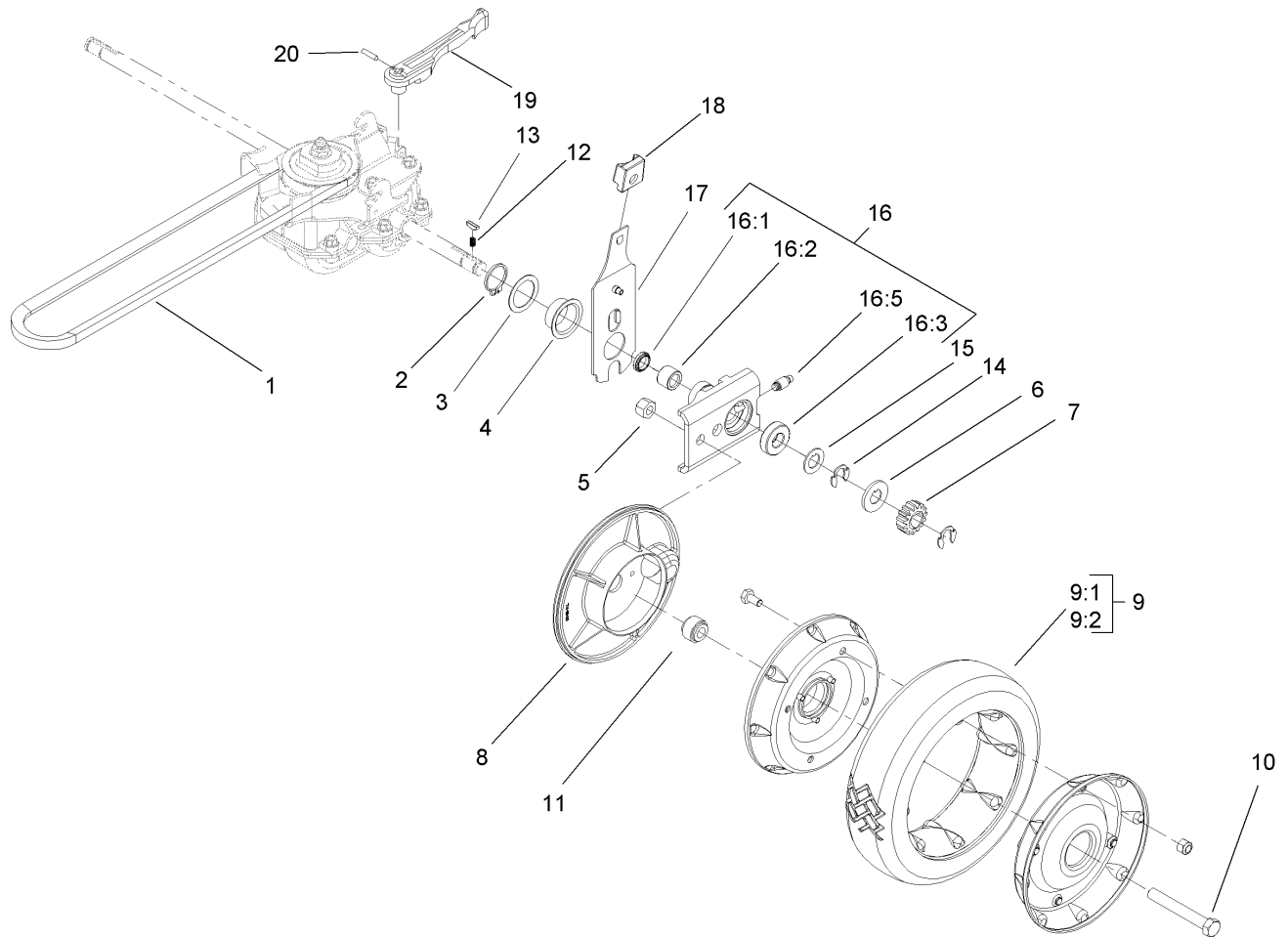

## Rear Drive and Wheel Assembly

Ref	Part No.	Qty.	Description
1	36-8070	1	V-Belt
2	32151-36	2	Ring-Retaining
3	74-1810	2	Washer
4	48-2170	2	Cap-End
5	32152-2	2	Nut-Lock, Cone
6	62-3830	2	Washer-Thrust, Outer
7	39-9160	2	Gear-Pinion
8	74-1640	2	Cover-Wheel
9	100-2860	2	Wheel And Tire ASM
9:1	53-7740	1	Tire
9:2		1	Wheel ASM
10	323-13	2	Screw-HH
11	74-1650	2	Spacer-Cover, Wheel
12	39-9650	2	Spring-Compression
13	612066	2	Key
14	32151-68	4	Ring-Retaining
15	49-7700	2	Washer-Thrust, Outer
16	74-1851	2	Pivot Arm ASM
16:1	47-6730	1	Seal-Oil
16:2	48-2060	1	Bearing-Roller
16:3	52-2450	1	Bearing-Wheel
16:5	92-6316	1	Zerk
17	66-7561	2	Rear Spring Arm ASM
18	25-7740	2	Knob-Arm

Ref	Part No.	Qty.	Description
19	74-1960	1	Lever-Shift
20	32121-99	1	Pin-Coil
99	106-0975	1	Grass Bag ASM
99	100-2512	1	Tube-Drain, Oil

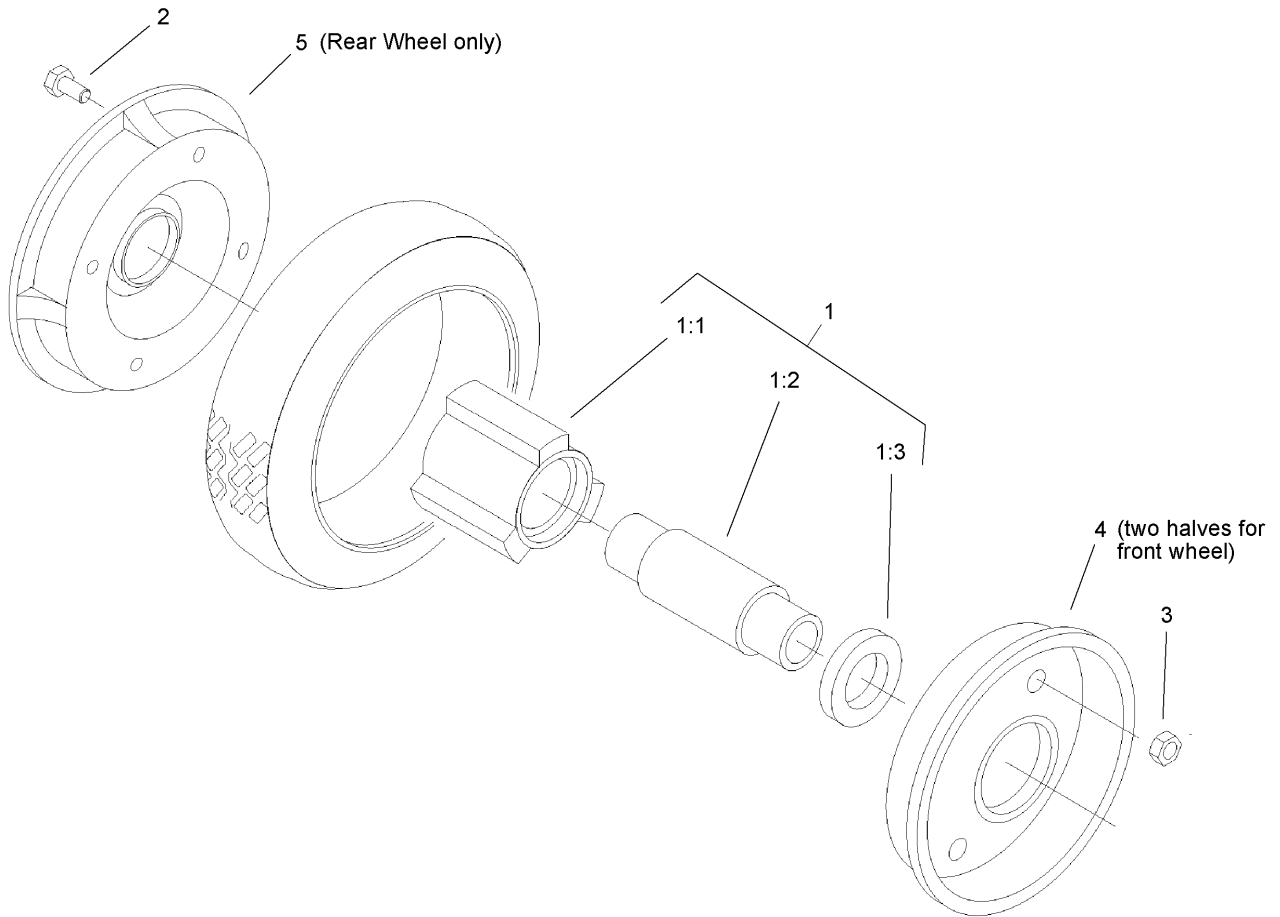

## Front and Rear Wheel Assembly

Ref	Part No.	Qty.	Description
1		1	Hub And Bearing ASM
1:1	52-2410	1	Hub-Bearing
1:2	52-2440	1	Spacer-Bearing
1:3	52-2450	2	Bearing-Wheel
2	321-2	4	Screw-HH
3	3296-42	4	Nut-Lock, NI
4	53-7780-06	1	Plate-Wheel, Half
5	92-4957-06	1	Wheel Half / Gear ASM

--	--	--	--



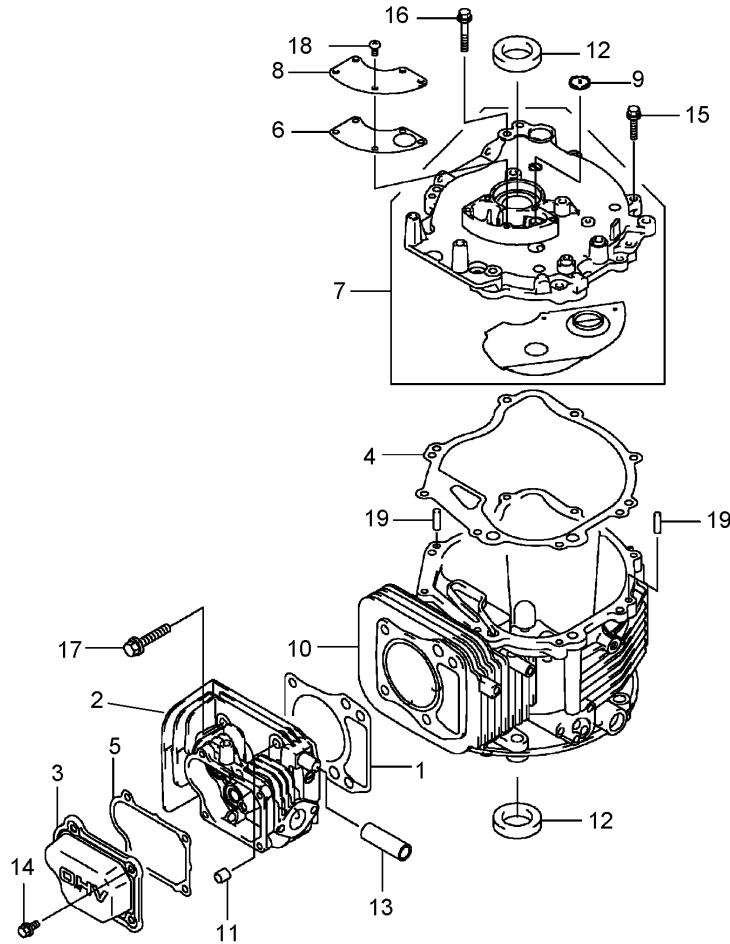

## Cylinder and Crankcase Assembly

Ref	Part No.	Qty.	Description
1	108-2500	1	Gasket-Head
2	108-2501	1	Head-Cylinder
3	108-2502	1	Case-Rocker
4	108-2503	1	Gasket
5	108-2504	1	Gasket-Case, Rocker
6	108-2505	1	Gasket-Breather
7	108-2506	1	Cover-Comp
8	108-2507	1	Cover-Breather
9	108-2508	1	Valve-Breather
10	108-2509	1	Crankcase-Comp
11	108-2510	2	Pin
12	108-2511	2	Seal-Oil
13	108-2512	1	Tube
14	100-2804	4	Bolt-Flanged
15	100-2610	7	Bolt-Flanged
16	108-2513	1	Bolt-Flange
17	108-2514	4	Bolt-Flange
18	100-2763	5	Screw-Pan
19	108-2515	2	Pin-Dowel

--	--	--	--

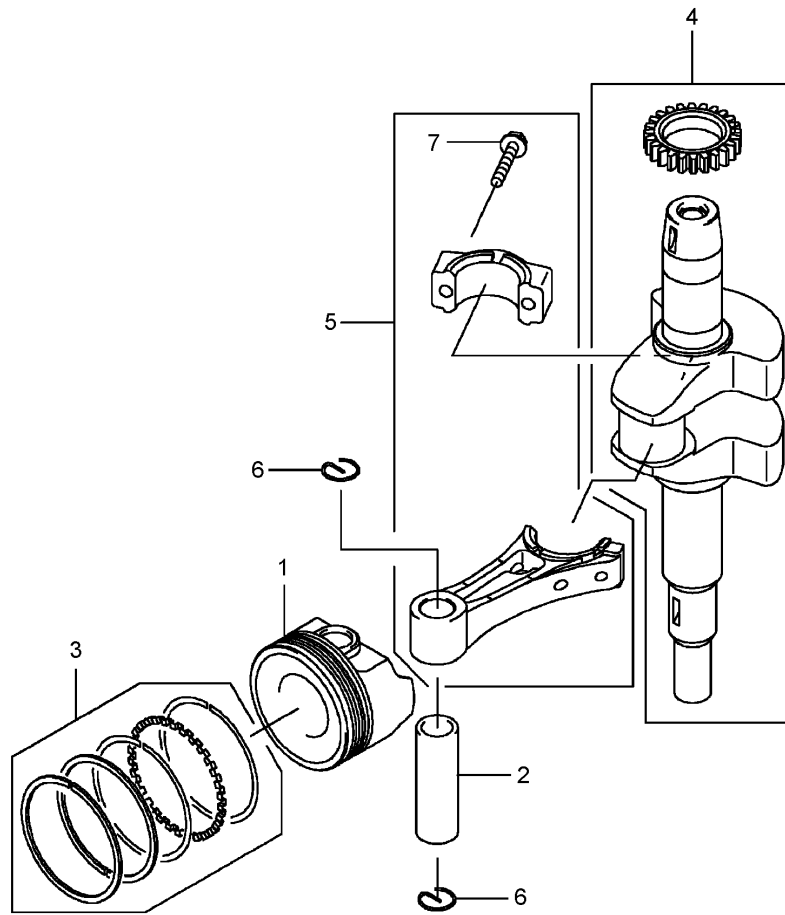

## Piston and Crankshaft Assembly

Ref	Part No.	Qty.	Description
1	108-2516	1	Piston-Engine
2	108-2517	1	Pin-Piston
3	108-2518	1	Ring-Set, Piston
4	108-2626	1	Crankshaft-Comp (Bbc)
5	108-2520	1	Connecting Rod ASM
6	108-2521	2	Ring-Snap
7	108-2522	2	Bolt-Flange



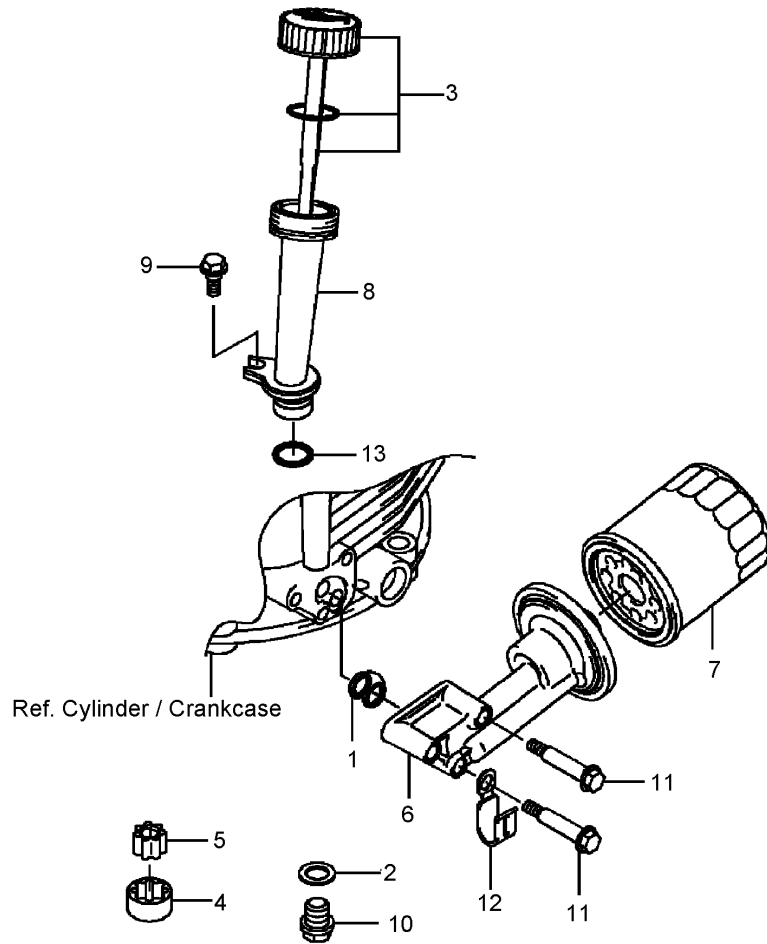

## Lubrication Equipment Assembly

Ref	Part No.	Qty.	Description
1	100-2644	1	Gasket
2	108-2538	1	Gasket
3	108-2539	1	Cap ASM
4	108-2540	1	Rotor-Pump
5	108-2541	1	Rotor-Pump
6	108-2542	1	Pipe
7	KW10761	1	Filter-Oil
8	108-2543	1	Filler
9	108-2544	1	Bolt
10	108-2545	1	Bolt
11	108-2546	3	Bolt
12	108-2547	1	Clamp
13	100-2690	1	O-Ring

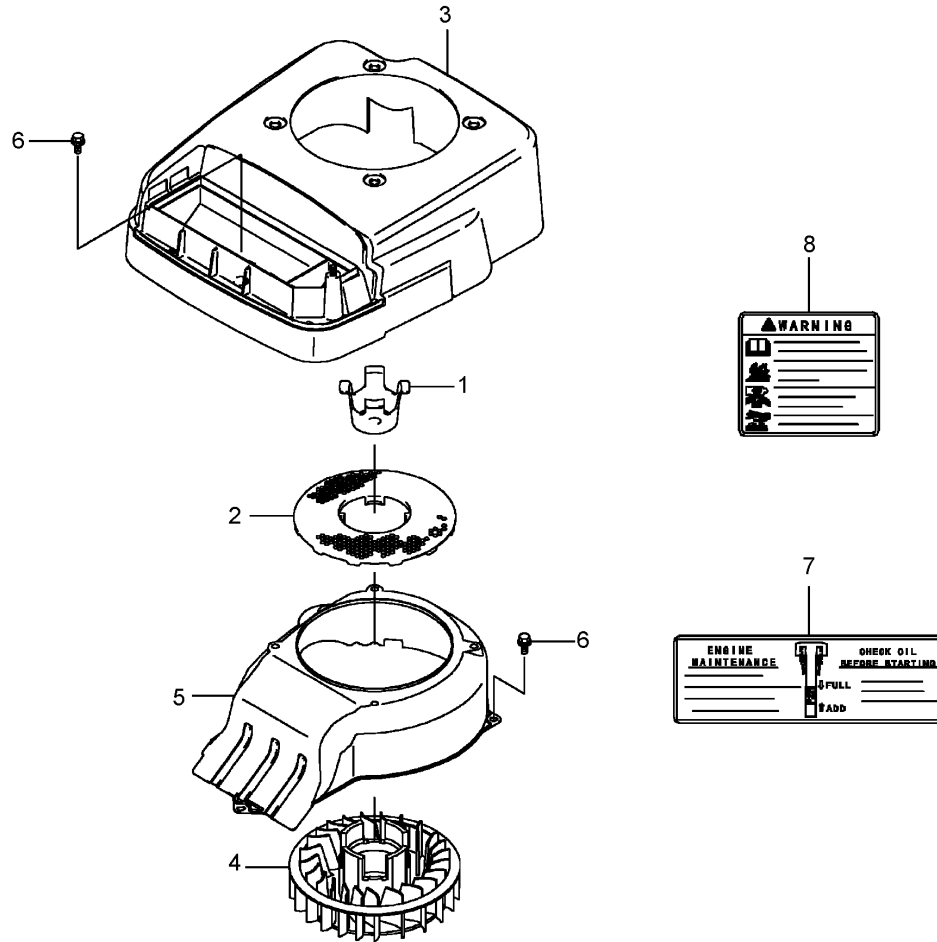

## Cooling Equipment Assembly

Ref	Part No.	Qty.	Description
1	108-2548	1	Bracket-Fan
2	108-2549	1	Screen
3	108-2550	1	Cover
4	108-2551	1	Fan
5	108-2552	1	Housing-Fan
6	100-2804	2	Bolt-Flanged
7	108-2624	1	Label-Manual
8	108-2625	1	Label-Warning

--	--	--	--

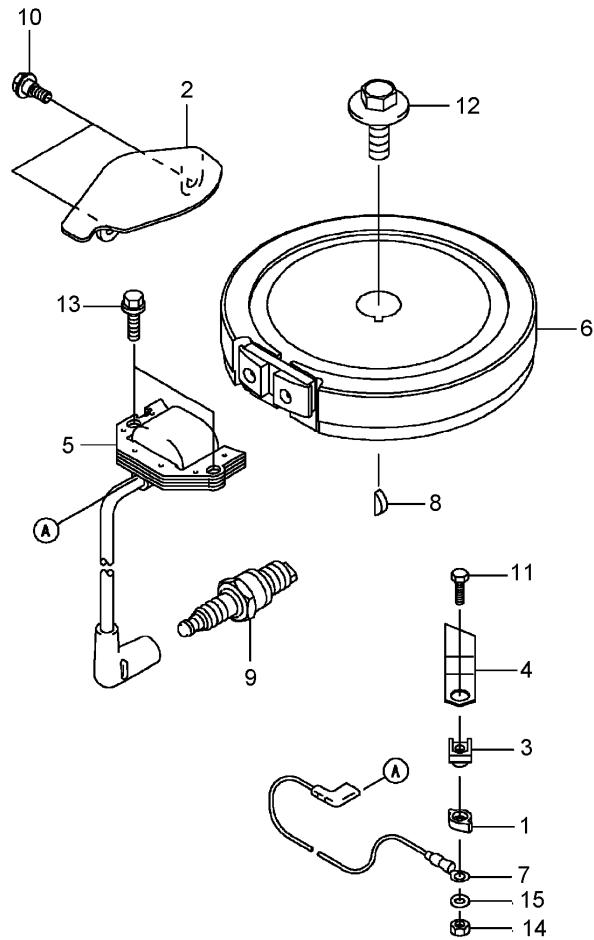

## Electrical Equipment Assembly

Ref	Part No.	Qty.	Description
1	100-2652	1	Cover
2	108-2553	1	Cover
3	100-2653	1	Insulator
4	100-2796	1	Terminal
5	108-2554	1	Coil Ignition ASM
6	108-2555	1	Flywheel
7	108-2556	1	Wire-Lead
8	93-8571	1	Key
9	KW10676	1	Spark Plug
10	108-2544	2	Bolt
11	108-2558	1	Bolt
12	108-2559	1	Bolt
13	95-9893	2	Bolt-Flanged
14	100-2668	1	Nut-Hex
15	100-2798	1	Washer-Plain

--	--	--	--





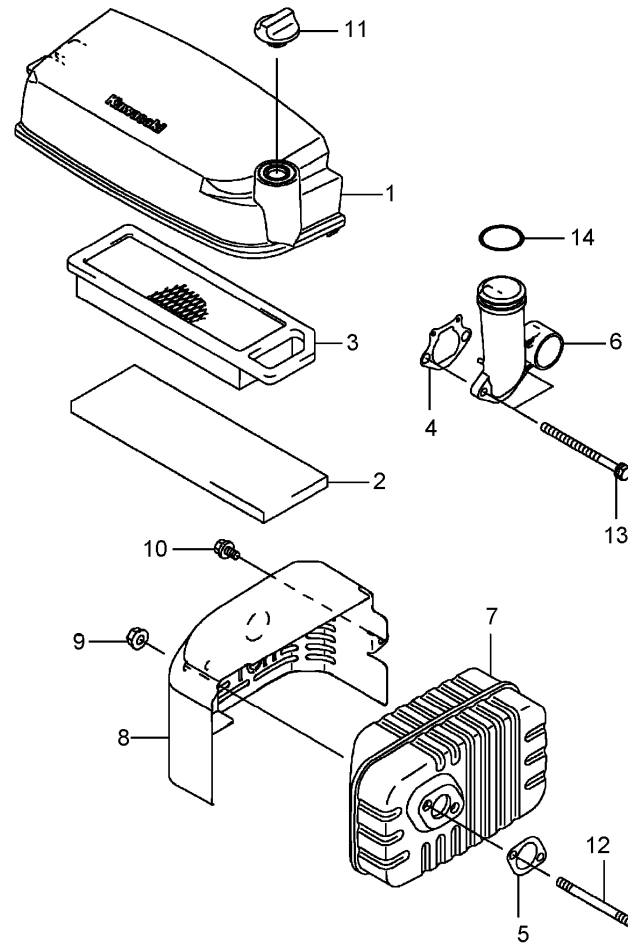

## Air Filter and Muffler Assembly

Ref	Part No.	Qty.	Description	
1	108-2602	1	Case-Filter, Air	
2	108-2603	1	Element-Filter, Air	
3	108-2604	1	Air Filter Element ASM	
4	108-2605	1	Gasket-Pipe, Intake	
5	108-2606	1	Gasket-Muffler	
6	108-2607	1	Pipe-Intake	
7	108-2608	1	Muffler	
8	108-2609	1	Cover-Muffler	
9	108-2610	2	Nut	
10	108-2611	1	Bolt	
11	108-2612	1	Nut	
12	100-2761	2	Bolt-Stud	
13	100-2762	2	Bolt	
14	108-2613	1	O-Ring	

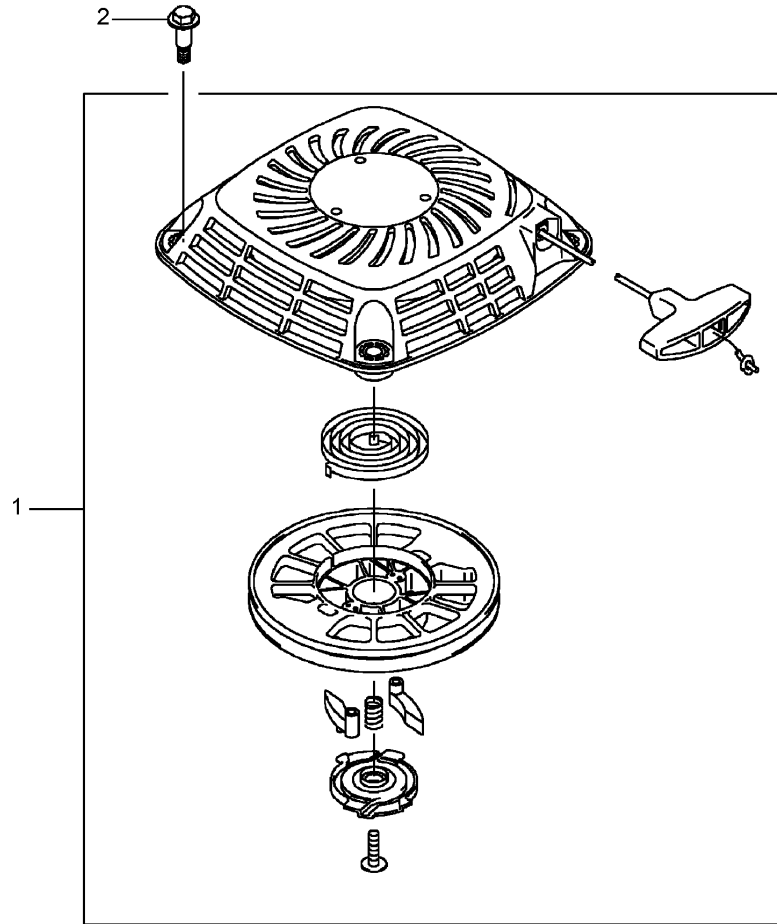

### Starter Assembly

Ref	Part No.	Qty.	Description				
1	108-2614	1	Starter-Recoil				
2	108-2615	4	Bolt				

## NOTES

## NOTES

## NOTES

