



21in Heavy-Duty Recycler[®]/Rear Bagger Lawnmower

Model No. 22176 - 250000001 and up.

Parts Catalog

Ordering Replacement Parts

To order replacement parts, please supply the part number, the quantity, and the description of each part desired.

Understanding Reference Numbers

Each Identified part in an illustration has a reference number. The reference number for a part also appears in the parts list, along with other information about the part.

This catalog uses two special reference number formats, one to indicate parts in a service assembly and another to indicate the quantity of a given part in an illustration.

Service Assembly Reference Numbers

Parts in service assemblies have reference numbers in the form a:b. The a represents the reference number of the entire service assembly and the b represents a sequential number unique to each part within the service assembly.

For example, a wheel assembly might be identified by reference number 6, the tire by 6:1, the valve by 6:2, and the wheel by 6:3. When you order the assembly identified by reference number 6, you receive all parts identified by reference numbers 6:1, 6:2, and 6:3. However, you may also order any part individually. Reference numbers of this type appear in illustrations and in part lists.

Reference Numbers Indicating Quantity

In an illustration, if a reference number indicates more than one part, the reference number has the form nX y. The n represents the quantity of the part, the X is the multiplication symbol, and the y represents the reference number.

For example, in an illustration, the reference number 2X 37 means that two of the parts identified by reference number 37 are indicated.

Contents

Description	Page	Description	Page
Deck, Chute and Wheel Assembly 3	Cylinder and Crankcase Assembly 13
Housing Assembly No. 98-7139 4	Piston and Crankshaft Assembly 14
Front Wheel and Tire Assembly 5	Valve and Camshaft Assembly 15
Wheel Assembly 6	Lubrication Equipment Assembly 16
Gear Case Assembly No. 74-1861 7	Cooling Equipment Assembly 17
Engine and Blade Assembly 8	Electrical Equipment Assembly 18
Handle Assembly 9	Control Equipment Assembly 19
Gearcase and Rear Wheel Assembly 10	Carburetor Assembly 20
Rear Wheel Assembly 11	Air Filter and Muffler Assembly 21
Grass Bag Assembly No. 106-0975 12	Starter Assembly 22
		Brake and Cover Assembly 23

Part Description Abbreviations

Part descriptions in this catalog may include the following abbreviations.

AR. as required	INC. incorporated
ASM. assembly	LH. left hand
CARR. carriage	NI. nylon insert
DEG. degrees	PPH. phillips pan head
FH. flat head	PTH. phillips truss head
GA. gauge	PTO. power take off
HF. hex flange	RH. right hand
HH. hex head	SFH. slotted fillister head
HHF. hex head flange	SHH. slotted hex head
HHFTF. hex head flange thread forming	SHWH. slotted hex washer head
HJ. hex jam	SPH. slotted pan head
HLH. hex lag head	SQH. square head
HOC. height-of-cut	SRH. slotted round head
HS. hex	STD. standard
HSBH. hex socket button head	TAP. self tapping
HSFH. hex socket flat head	TTH. torx truss head
HSH. hex socket head	WH. wing head
HWH. hex washer head	
HWHTF. hex washer head thread forming	
HYD. hydraulic	

Footnotes

- ❶ Not serviced separately

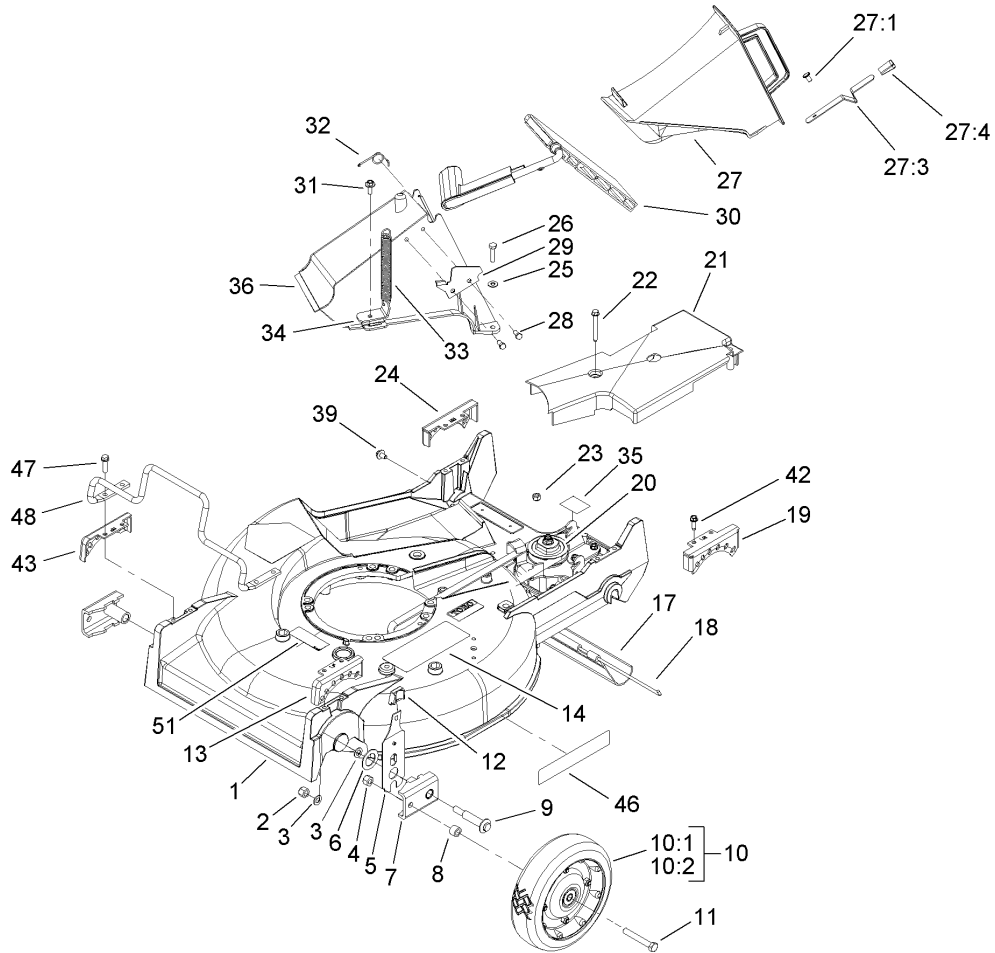

Deck, Chute and Wheel Assembly

Ref	Part No.	Qty.	Description
1	98-7139	1	Housing
2	3296-6	2	Nut-Lock
3	40-1940	4	Washer
4	32152-2	2	Nut-Lock, Cone
5	66-7560	2	Front Spring Arm ASM
6	257-3	2	Washer-Thrust
7	61-8300	2	Arm-Pivot, Front
8	52-2480	2	Spacer-Wheel
9	27-6232	2	Bolt-Wheel
10	100-2870	2	Wheel And Tire ASM
10:1	53-7740	1	Tire
10:2		1	Wheel ASM
11	323-12	2	Screw-HH
12	25-7740	2	Knob-Arm
13	49-8760	1	Quadrant-Front, LH
14	104-8589	1	Decal-Warning
17	44-0580	1	Shield-Trailing
18	33-3208	1	Rod-Shield
19	49-8740	1	Quadrant-Rear, LH
20	74-1861	1	Gear Case ASM
21	74-1770	1	Cover-Belt
22	37-7260	2	Screw-HH
23	3296-42	2	Nut-Lock, NI
24	49-8750	1	Quadrant-Rear, RH

Ref	Part No.	Qty.	Description
25	3256-22	2	Washer-Flat
26	321-7	2	Screw-HH
27	77-0500	1	Discharge Plug ASM
27:1	3295-35	1	Rivet-Head, Flat
27:3	76-4640	1	Latch-Plug, Discharge
27:4	76-4650	1	Grip-Latch
28	46-8090	2	Screw-Plastite
29	93-3154	1	Latch-Plate
30	93-7351	1	Discharge Door ASM
31	46-6811	1	Screw-HWH
32	80-3770	1	Retainer-Door
33	76-4660	1	Spring-Door
34	71-9350	1	Bracket-Spring
35	52-2620	1	Label-Grease
36	82-9152	1	Tunnel-Discharge
39	46-6810	1	Screw And Washer ASM
42	49-2040	4	Screw-Tapping
43	49-8770	1	Quadrant-Front, RH
46	106-0689	1	Decal
47	32144-86	4	Screw-Hwh, Thread Forming
48	99-6722	1	Guard-Engine
51	68-7410	1	Decal-Blade

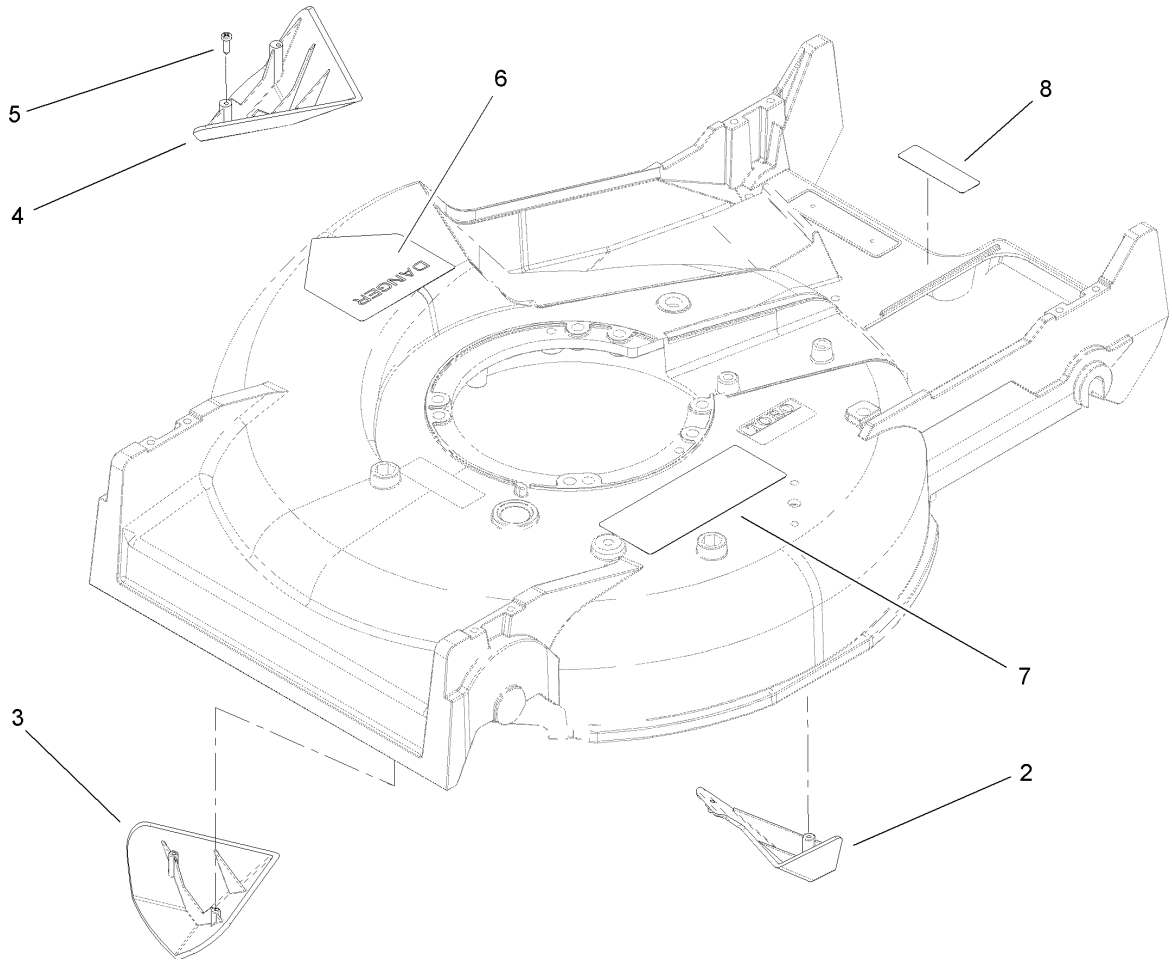

Housing Assembly No. 98-7139

Ref	Part No.	Qty.	Description				
2	92-1750	1	Kicker-Rear				
3	92-1720	1	Kicker-Front				
4	92-1730	1	Kicker-RH				
5	32144-111	6	Screw-PPH				
6	39-5770	1	Decal-Danger				
7	93-0248	1	Decal-Warning				
8	92-1779	1	Decal-Warning				

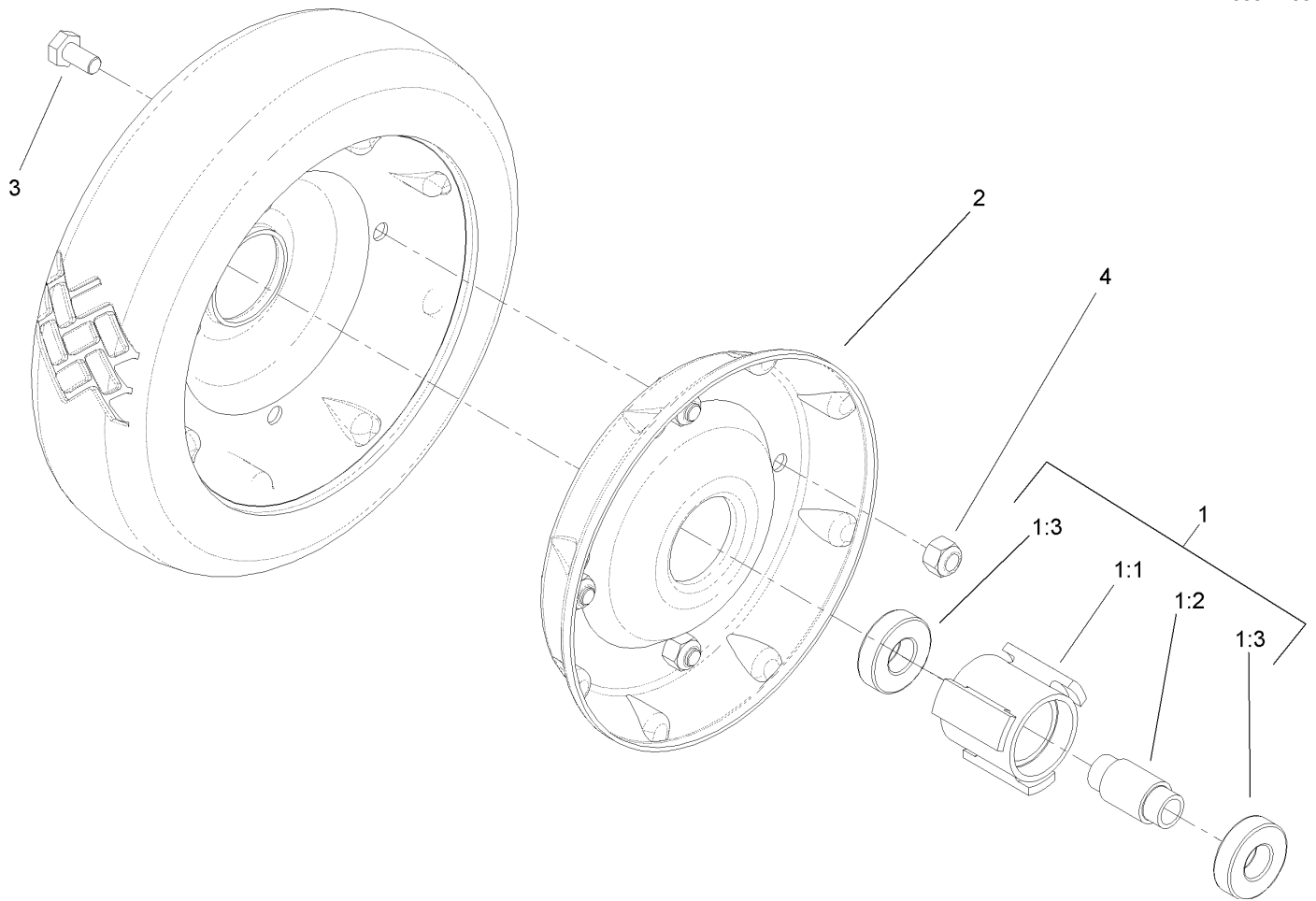

Front Wheel and Tire Assembly

Ref	Part No.	Qty.	Description
1		1	Hub And Bearing ASM
1:1	52-2410	1	Hub-Bearing
1:2	52-2440	1	Spacer-Bearing
1:3	52-2450	2	Bearing-Wheel
2	53-7780-06	2	Plate-Wheel, Half
3	321-2	4	Screw-HH
4	3296-42	4	Nut-Lock, NI

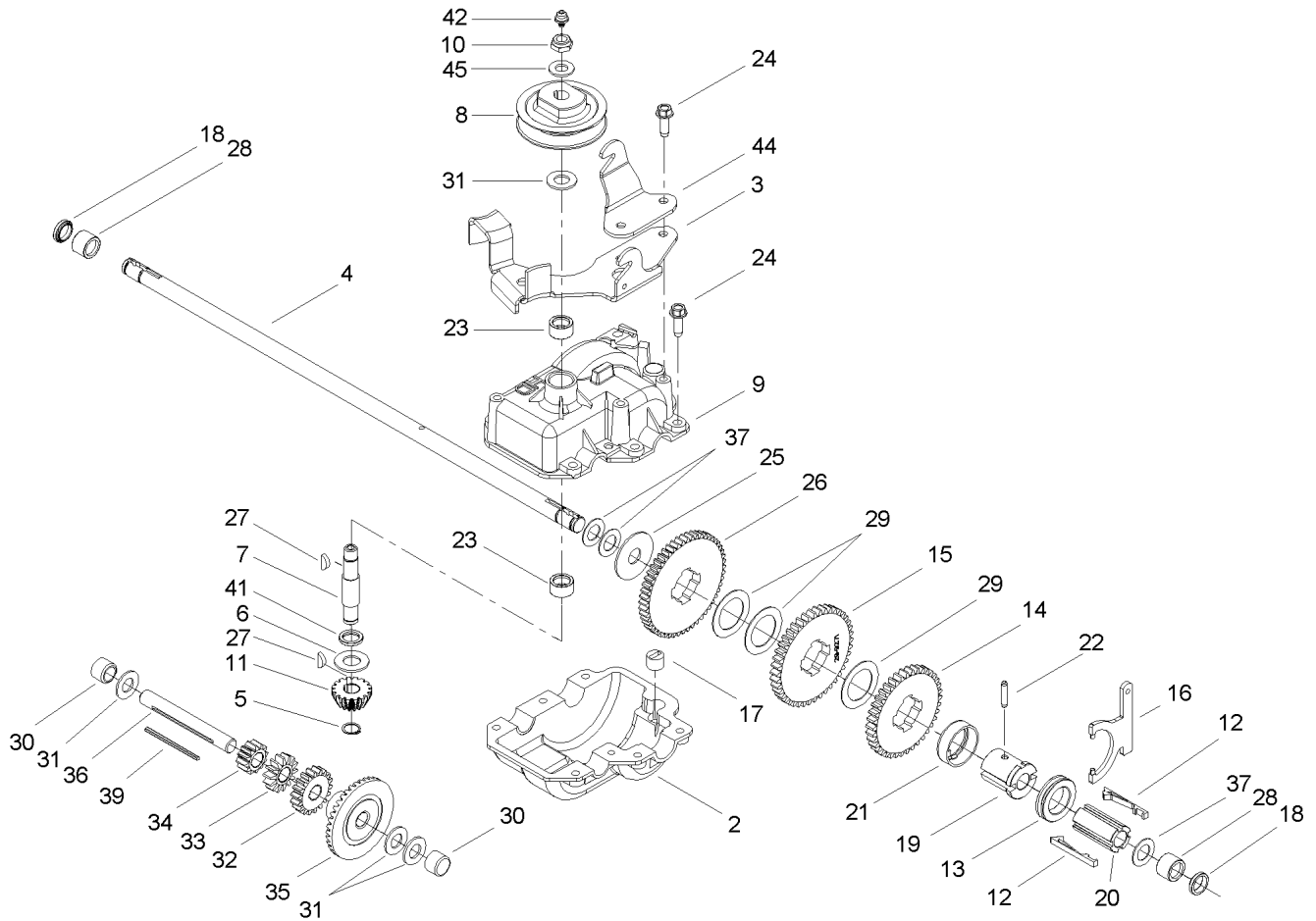

Gear Case Assembly No. 74-1861

Ref	Part No.	Qty.	Description
2	74-1920	1	Case-Gear, Lower
3	49-8461-03	1	Bracket-Guide, Belt
4	74-1890	1	Shaft-Output
5	32151-57	1	Ring-Retaining
6	47-2910	1	Washer-Thrust
7	68-8190	1	Shaft-Input
8	39-6740	1	Pulley
9	74-1880	1	Case-Gear, Upper
10	3296-5	1	Nut-Lock
11	39-6660	1	Pinion-Bevel
12	29-9330	2	Key-Shift
13	29-9340	1	Collar-Shift
14	42-4740	1	Gear-38 Tooth
15	29-9271	1	Gear-42 Tooth
16	60-8870	1	Yoke-Shift
17	29-9570	1	Bushing-Yoke
18	47-6730	2	Seal-Oil
19	55-8010	1	Sleeve-Gear
20	39-6720	1	Sleeve
21	55-8020	1	Retainer-Key
22	3285-19	1	Pin-Groove
23	47-7270	2	Bearing
24	49-2040	6	Screw-Tapping
25	29-9690	1	Washer

Ref	Part No.	Qty.	Description
26	46-3560	1	Gear
27	3257-1	2	Key-Woodruff
28	48-2060	2	Bearing-Roller
29	36-4770	3	Washer
30	252-103	2	Bearing-Closed
31	36-4792	4	Washer-Thrust
32	39-6650	1	Gear-18t
33	46-3550	1	Gear-14t
34	46-3540	1	Gear-12t
35	74-1760	1	Gear-Bevel
36	53-7950	1	Shaft-Intermediate
37	36-4780	3	Washer
39	39-7842	1	Key
41	47-7260	1	Seal
42	302-63	1	Zerk
44	74-1750-03	1	Bracket-Engage, Traction
45	3256-45	1	Washer-Flat

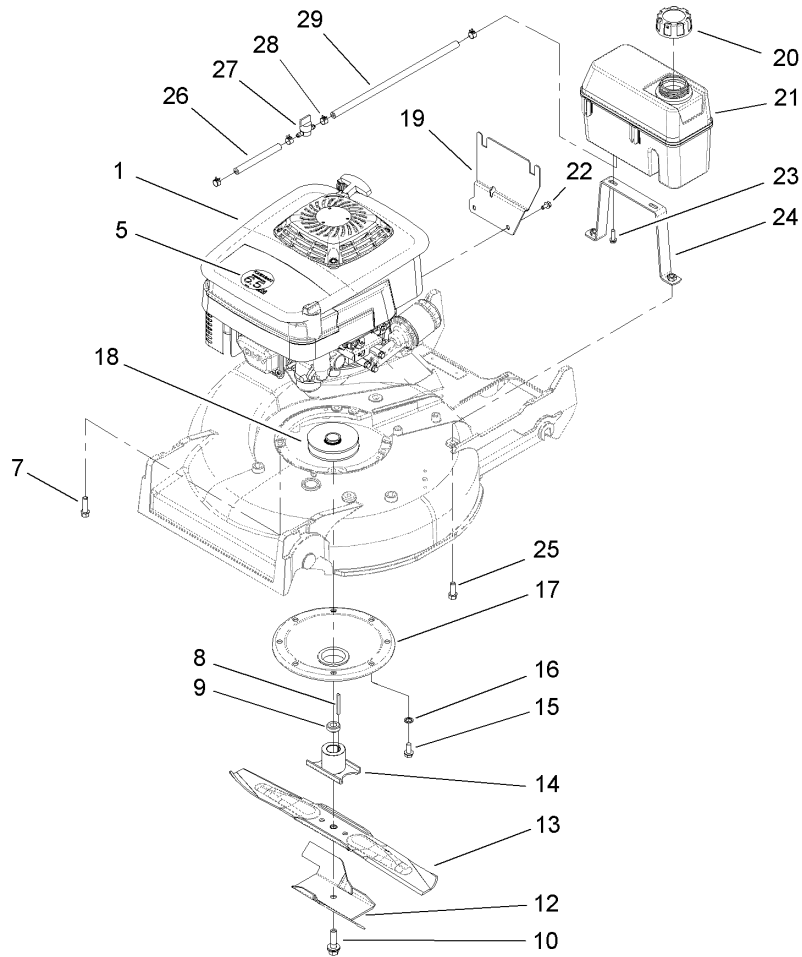

Engine and Blade Assembly

Ref	Part No.	Qty.	Description
1		1	Engine-Kawasaki, Fj180v-As10
5	107-4201	1	Decal - Recoil
7	95-1727	4	Screw-Taptite
8	5-1077	1	Key-Square
9	103-3795	1	Spacer-Retainer, Blade
10	105-8579	1	Bolt-Blade
12	92-1599-03	1	Stiffener-Blade
13	91-2256-03	1	Blade
14	52-2170	1	Retainer-Blade
15	32144-70	3	Screw-HH
16	3254-6	3	Washer-Lock, Internal
17	65-5860	1	Protector-Crankshaft
18	46-7910	1	Pulley-Driver
19	106-0908-03	1	Bracket-Tank
20	93-7198	1	Gas Cap ASM
21	106-0625	1	Tank-Fuel
22	104-2628	3	Screw-HWH
23	46-8091	2	Screw-HWH
24	107-4131-03	1	Tank Base
25	95-1726	2	Screw-Taptite
26	47-2983	1	Hose-Fuel
27	1-603770	1	Valve-Fuel
28	2412-98	4	Clamp
29	106-0999	1	Hose-Gas

--	--	--	--

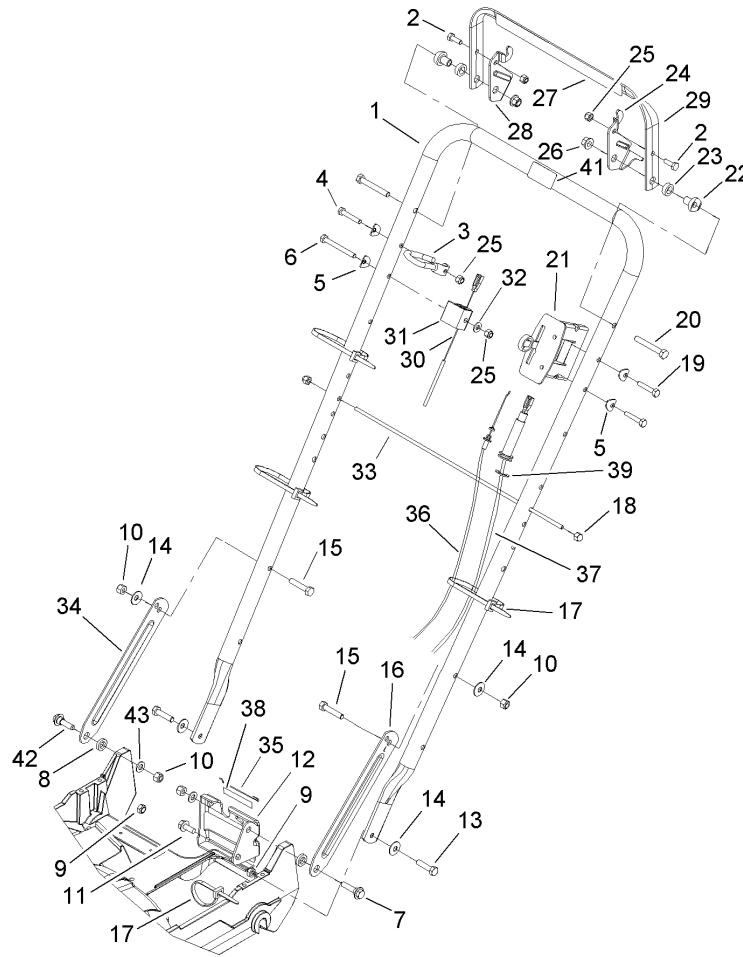

Handle Assembly

Ref	Part No.	Qty.	Description
1	98-2000-03	1	Handle
2	321-4	2	Screw-HH
3	46-8081	1	Guide-Rope
4	321-9	1	Screw-HH
5	3-7501	4	Washer
6	321-15	1	Screw-HH
7	27-7210	1	Screw-Shoulder
8	3-3287	2	Spacer-Latch, Handle
9	3296-47	2	Nut-Lock, NI
10	3296-29	4	Nut-Lock, NI
11	32144-70	1	Screw-HH
12	74-1741	1	Bracket-Adjustment, Traction
13	322-6	2	Screw-HH
14	3290-456	4	Washer-Belleville
15	322-7	2	Screw-HH
16	100-3298-03	1	Latch-Handle, LH
17	3290-378	5	Tie-Cable
18	32111-7	2	Nut-Cap
19	321-13	2	Screw-HH
20	322-11	2	Screw-HH
21	103-5296	1	Control-Throttle
22	49-1630	2	Spacer-Support
23	256-276	2	Spacer-Nylon
24	66-5350	1	Lever-Control

Ref	Part No.	Qty.	Description
25	3296-42	4	Nut-Lock, NI
26	3296-58	2	Nut-Lock NI
27	106-0690	1	Decal-Traction
28	77-5270	1	Lever-Control
29	61-8270-03	1	Bar-Control
30	103-2683	1	Cable-Brake
31	46-6980	1	Support-Cable
32	3256-22	1	Washer-Flat
33	48-2810	1	Rod-Support, Bag
34	100-3297-03	1	Latch-Handle, RH
35	46-7030	1	Retainer-Cable
36	74-1791	1	Cable-Traction
37	106-0888	1	Throttle Cable ASM
38	74-1970	1	Decal-Position, Gear
39	32151-86	2	E-Ring
41	98-4387	1	Decal-Protection, Ear
42	27-7211	1	Screw-Shoulder
43	3256-23	2	Washer-Flat

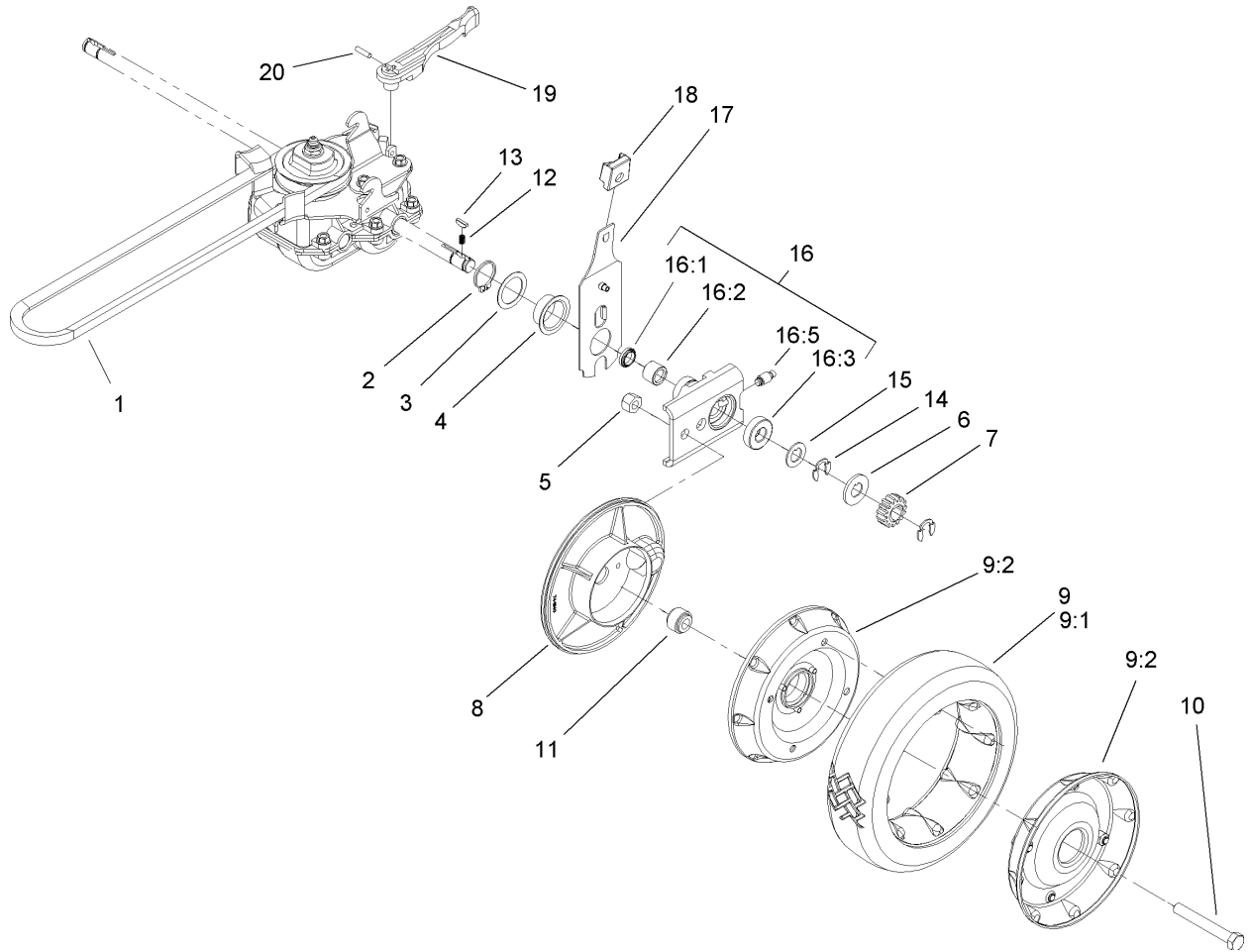

Gearcase and Rear Wheel Assembly

Ref	Part No.	Qty.	Description
1	36-8070	1	V-Belt
2	32151-36	2	Ring-Retaining
3	74-1810	2	Washer
4	48-2170	2	Cap-End
5	32152-2	2	Nut-Lock, Cone
6	62-3830	2	Washer-Thrust, Outer
7	39-9160	2	Gear-Pinion
8	74-1640	2	Cover-Wheel
9	100-2860	2	Wheel And Tire ASM
9:1	53-7740	1	Tire
9:2		1	Wheel ASM
10	323-13	2	Screw-HH
11	74-1650	2	Spacer-Cover, Wheel
12	39-9650	2	Spring-Compression
13	612066	2	Key
14	32151-68	4	Ring-Retaining
15	49-7700	2	Washer-Thrust, Outer
16	74-1851	2	Pivot Arm ASM
16:1	47-6730	1	Seal-Oil
16:2	48-2060	1	Bearing-Roller
16:3	52-2450	1	Bearing-Wheel
16:5	92-6316	1	Zerk
17	66-7561	2	Rear Spring Arm ASM
18	25-7740	2	Knob-Arm

Ref	Part No.	Qty.	Description
19	74-1960	1	Lever-Shift
20	32121-99	1	Pin-Coil
99	106-0975	1	Grass Bag ASM

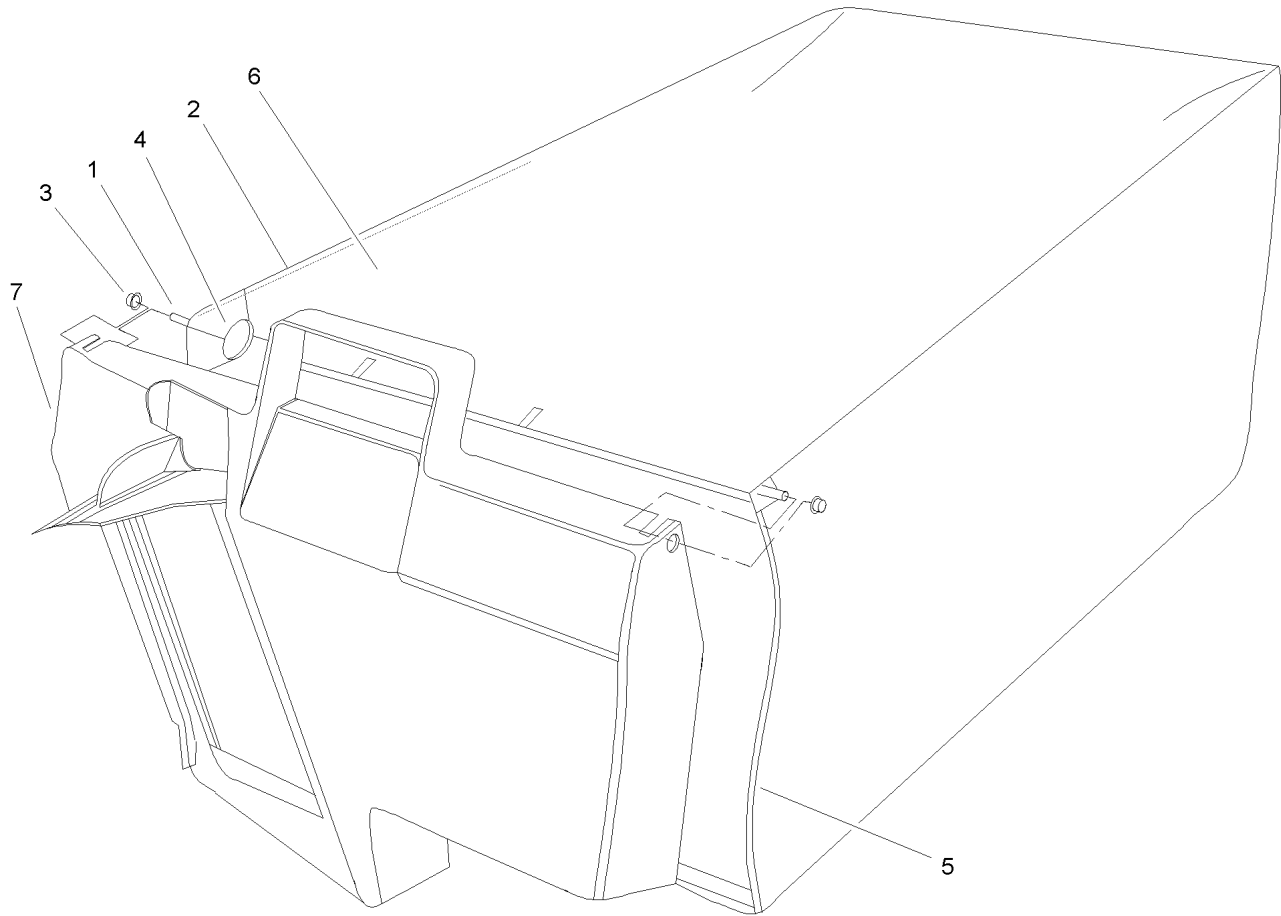

Grass Bag Assembly No. 106-0975

Ref	Part No.	Qty.	Description
1	33-4820	1	Hinge-Door, Bag
2	42-4030	1	Frame-Bag, Upper
3	3290-422	2	Nut-Push
4	36-6910	2	Spring
5	42-4020	1	Frame-Bag
6	106-0926	1	Bag-Grass
7	48-2840	1	Door-Bag, Grass

--	--	--	--

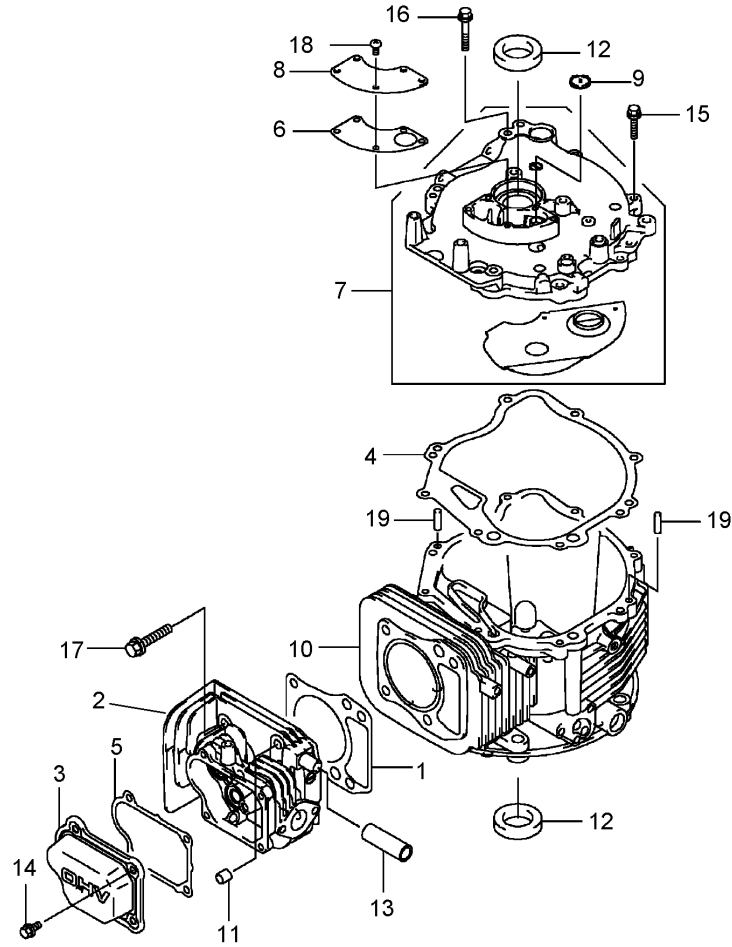

Cylinder and Crankcase Assembly

Ref	Part No.	Qty.	Description
1	108-2627	1	Gasket-Head
2	108-2501	1	Head-Cylinder
3	108-2502	1	Case-Rocker
4	108-2503	1	Gasket
5	108-2504	1	Gasket-Case, Rocker
6	108-2505	1	Gasket-Breather
7	108-2506	1	Cover-Comp
8	108-2507	1	Cover-Breather
9	108-2508	1	Valve-Breather
10	108-2509	1	Crankcase-Comp
11	108-2510	2	Pin
12	108-2511	2	Seal-Oil
13	108-2512	1	Tube
14	100-2804	4	Bolt-Flanged
15	100-2610	7	Bolt-Flanged
16	108-2513	1	Bolt-Flange
17	108-2514	4	Bolt-Flange
18	100-2763	5	Screw-Pan
19	108-2515	2	Pin-Dowel

--	--	--	--

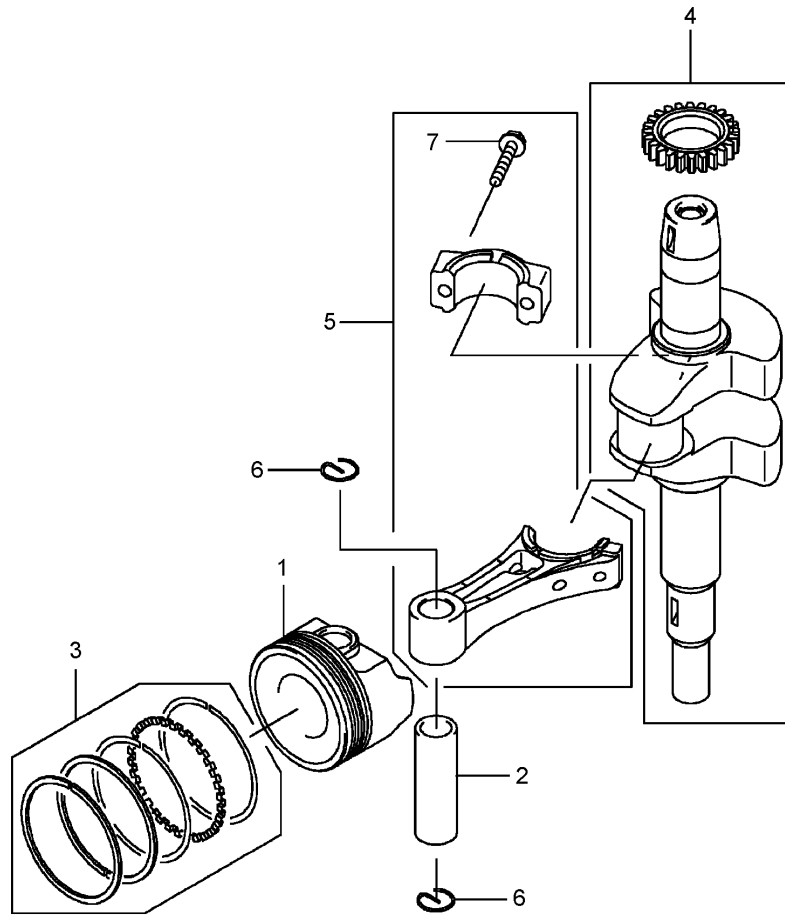

Piston and Crankshaft Assembly

Ref	Part No.	Qty.	Description	
1	108-2516	1	Piston-Engine	
2	108-2517	1	Pin-Piston	
3	108-2518	1	Ring-Set, Piston	
4	108-2519	1	Crankshaft	
5	108-2520	1	Connecting Rod ASM	
6	108-2521	2	Ring-Snap	
7	108-2522	2	Bolt-Flange	

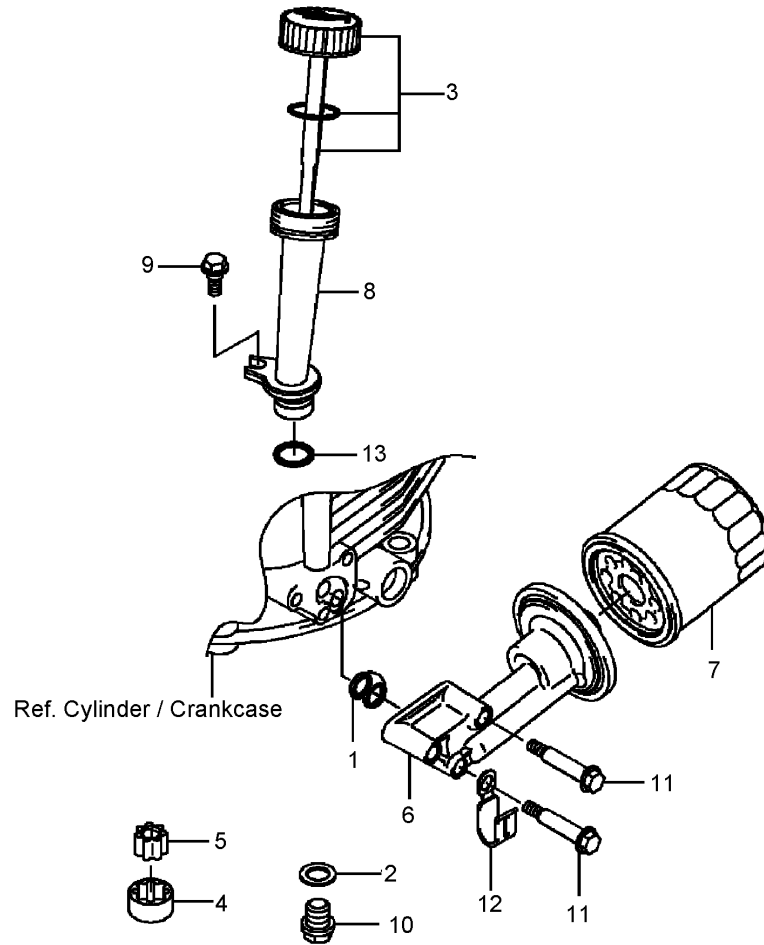

Lubrication Equipment Assembly

Ref	Part No.	Qty.	Description				
1	100-2644	1	Gasket				
2	108-2538	1	Gasket				
3	108-2539	1	Cap ASM				
4	108-2540	1	Rotor-Pump				
5	108-2541	1	Rotor-Pump				
6	108-2542	1	Pipe				
7	KW10761	1	Filter-Oil				
8	108-2543	1	Filler				
9	108-2544	1	Bolt				
10	108-2545	1	Bolt				
11	108-2546	3	Bolt				
12	108-2547	1	Clamp				
13	100-2690	1	O-Ring				

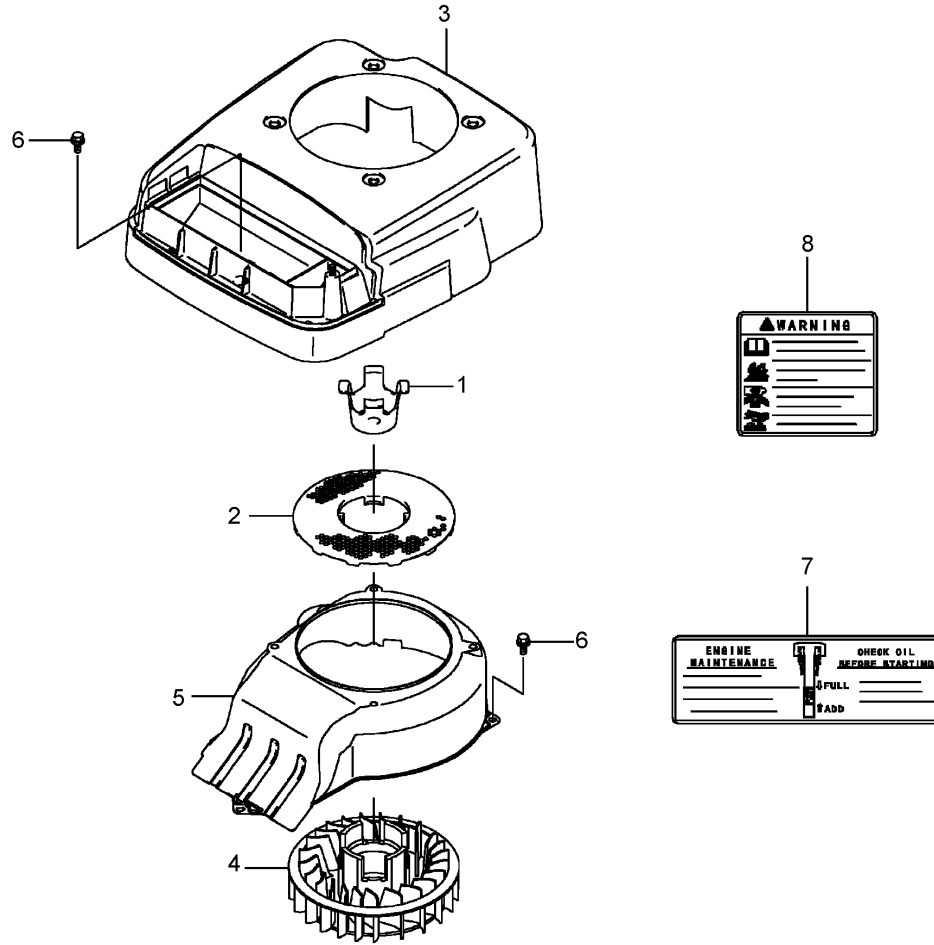

Cooling Equipment Assembly

Ref	Part No.	Qty.	Description	
1	108-2548	1	Bracket-Fan	
2	108-2549	1	Screen	
3	108-2550	1	Cover	
4	108-2551	1	Fan	
5	108-2552	1	Housing-Fan	
6	100-2804	2	Bolt-Flanged	
7	108-2624	1	Label-Manual	
8	108-2625	1	Label-Warning	

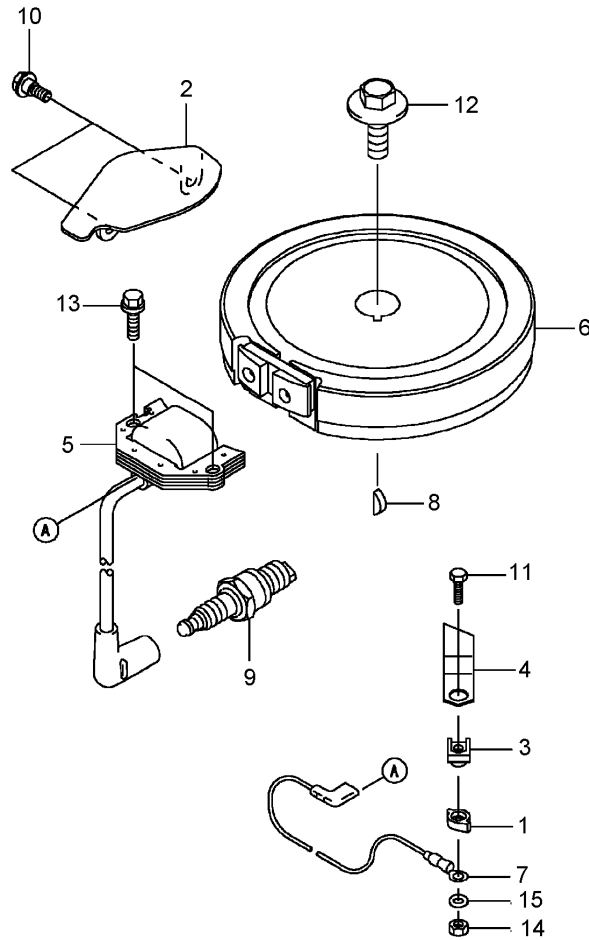

Electrical Equipment Assembly

Ref	Part No.	Qty.	Description				
1	100-2652	1	Cover				
2	108-2553	1	Cover				
3	100-2653	1	Insulator				
4	100-2796	1	Terminal				
5	108-2554	1	Coil Ignition ASM				
6	108-2555	1	Flywheel				
7	108-2556	1	Wire-Lead				
8	93-8571	1	Key				
9	KW10676	1	Spark Plug				
10	108-2544	2	Bolt				
11	108-2558	1	Bolt				
12	108-2559	1	Bolt				
13	95-9893	2	Bolt-Flanged				
14	100-2668	1	Nut-Hex				
15	100-2798	1	Washer-Plain				

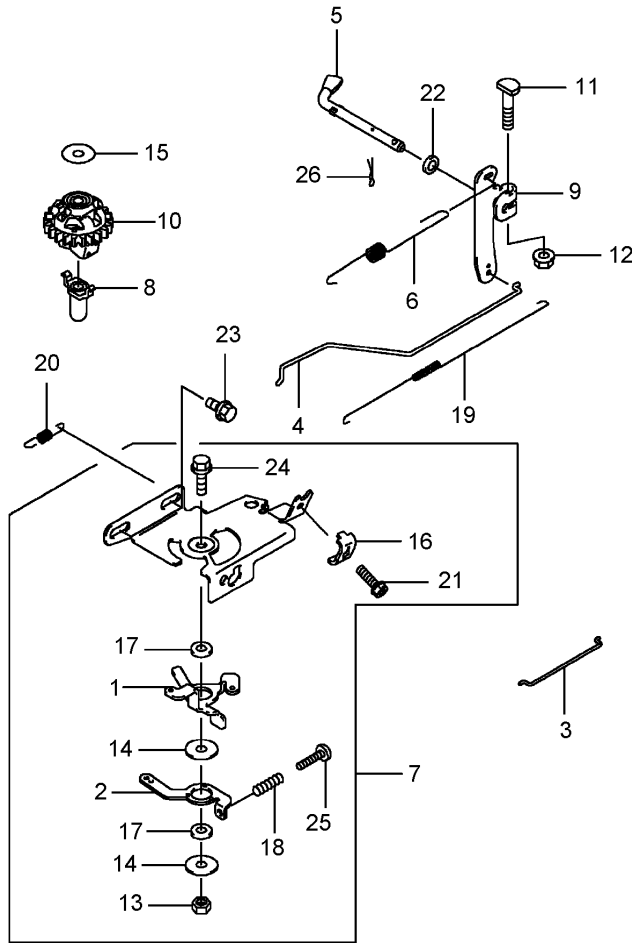

Control Equipment Assembly

Ref	Part No.	Qty.	Description
1	108-2560	1	Lever
2	108-2561	1	Lever
3	108-2562	1	Link-Choke
4	108-2563	1	Link-Throttle
5	108-2564	1	Arm-Pivot
6	108-2565	1	Spring-Govenor
7	108-2566	1	Control Panel ASM
8	108-2567	1	Sleeve
9	108-2568	1	Arm-Governor
10	108-2569	1	Governor ASM
11	108-2570	1	Bolt
12	108-2571	1	Nut
13	108-2572	1	Nut
14	100-2715	2	Washer
15	93-8612	1	Washer
16	95-9849	1	Clamp
17	100-2718	2	Collar
18	93-8588	1	Spring
19	108-2573	1	Spring-Throttle
20	108-2574	1	Spring
21	95-9853	1	Bolt
22	108-2575	1	Washer
23	100-2804	2	Bolt-Flanged
24	108-2576	1	Bolt-Flange

Ref	Part No.	Qty.	Description
25	108-2577	1	Screw-Pan
26	108-2578	1	Pin-Snap

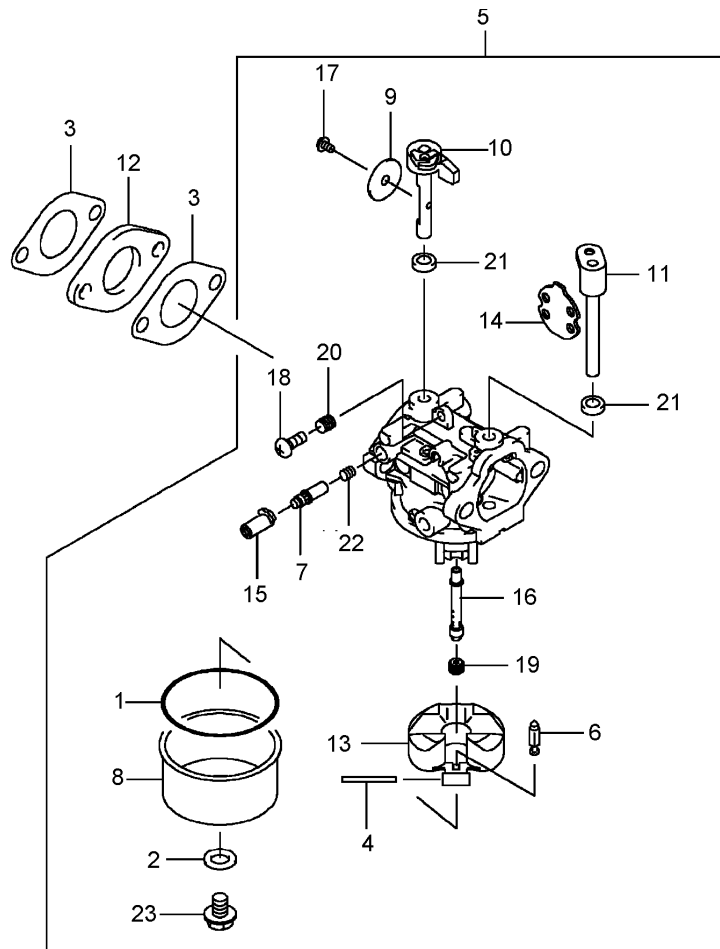

Carburetor Assembly

Ref	Part No.	Qty.	Description
1	108-2579	1	Gasket
2	108-2580	1	Gasket
3	108-2581	2	Gasket
4	108-2582	1	Shaft
5	108-2583	1	Carburetor ASM
6	108-2584	1	Needle-Jet
7	108-2585	1	Screw-Pilot,air
8	108-2586	1	Chamber-Float
9	108-2587	1	Valve-Throttle
10	108-2588	1	Shaft-Carburetor
11	108-2589	1	Shaft-Carburetor
12	108-2590	1	Insulator
13	108-2591	1	Float ASM
14	108-2592	1	Choke Valve ASM
15	108-2593	1	Limiter
16	108-2594	1	Nozzle-Main
17	108-2595	1	Screw
18	108-2596	1	Screw
19	108-2597	1	Jet-Main (#74)
20	108-2598	1	Spring
21	108-2599	2	Seal
22	108-2600	1	Spring
23	108-2601	1	Screw

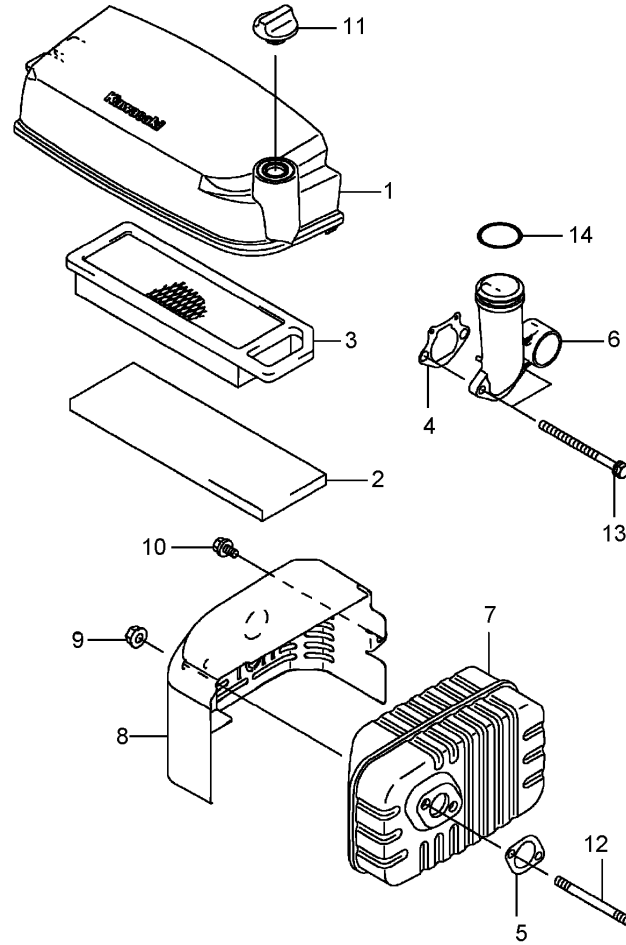

Air Filter and Muffler Assembly

Ref	Part No.	Qty.	Description	
1	108-2602	1	Case-Filter, Air	
2	108-2603	1	Element-Filter, Air	
3	108-2604	1	Air Filter Element ASM	
4	108-2605	1	Gasket-Pipe, Intake	
5	108-2606	1	Gasket-Muffler	
6	108-2607	1	Pipe-Intake	
7	108-2608	1	Muffler	
8	108-2609	1	Cover-Muffler	
9	108-2610	2	Nut	
10	108-2611	1	Bolt	
11	108-2612	1	Nut	
12	100-2761	2	Bolt-Stud	
13	100-2762	2	Bolt	
14	108-2613	1	O-Ring	

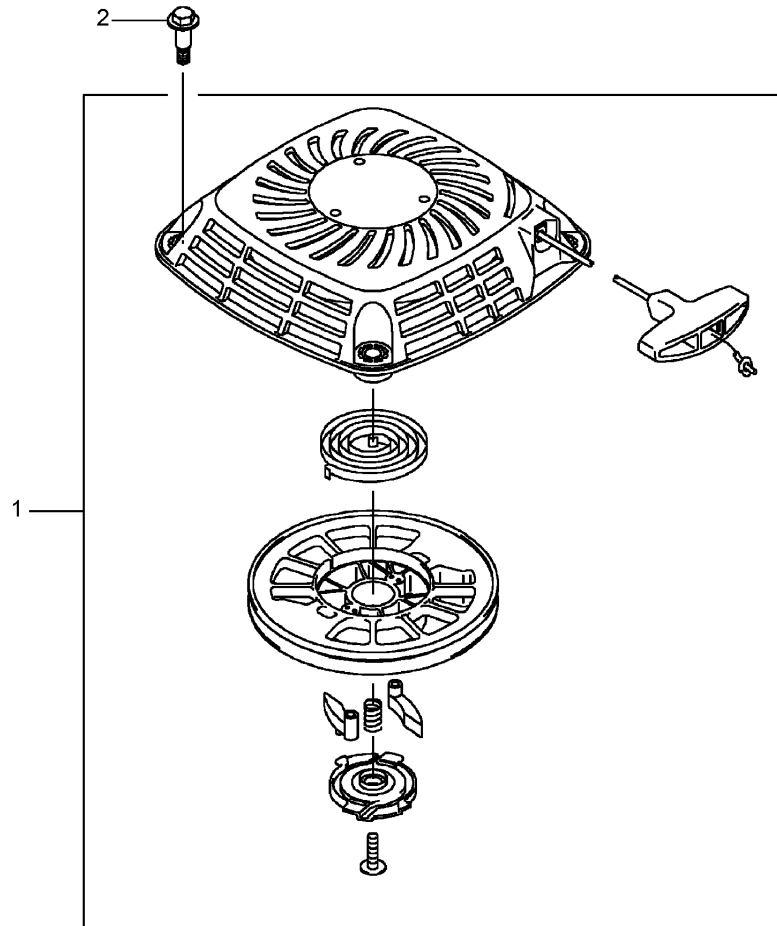

Starter Assembly

Ref	Part No.	Qty.	Description
1	108-2614	1	Starter-Recoil
2	108-2615	4	Bolt

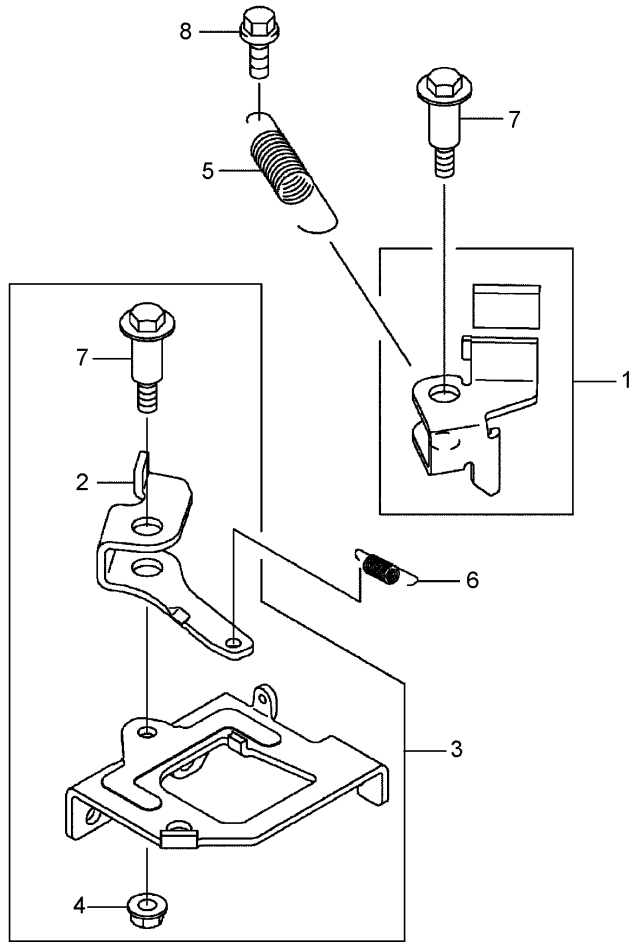

Brake and Cover Assembly

Ref	Part No.	Qty.	Description				
1	108-2616	1	Lever				
2	108-2617	1	Arm				
3	108-2618	1	Brake Panel ASM				
4	108-2619	1	Nut				
5	108-2620	1	Spring				
6	108-2621	1	Spring				
7	108-2622	2	Bolt				
8	108-2623	1	Bolt-Flange				

