



11-Blade DPA Reel Mower Greensmaster® 3000 Series

Model No. 04611 - 250000001 and up.

Parts Catalog

Ordering Replacement Parts

To order replacement parts, please supply the part number, the quantity, and the description of each part desired.

Understanding Reference Numbers

Each Identified part in an illustration has a reference number. The reference number for a part also appears in the parts list, along with other information about the part.

This catalog uses two special reference number formats, one to indicate parts in a service assembly and another to indicate the quantity of a given part in an illustration.

Service Assembly Reference Numbers

Parts in service assemblies have reference numbers in the form a:b. The a represents the reference number of the entire service assembly and the b represents a sequential number unique to each part within the service assembly.

For example, a wheel assembly might be identified by reference number 6, the tire by 6:1, the valve by 6:2, and the wheel by 6:3. When you order the assembly identified by reference number 6, you receive all parts identified by reference numbers 6:1, 6:2, and 6:3. However, you may also order any part individually. Reference numbers of this type appear in illustrations and in part lists.

Reference Numbers Indicating Quantity

In an illustration, if a reference number indicates more than one part, the reference number has the form nX y. The n represents the quantity of the part, the X is the multiplication symbol, and the y represents the reference number.

For example, in an illustration, the reference number 2X 37 means that two of the parts identified by reference number 37 are indicated.

Contents

Description	Page	Description	Page
Frame Assembly 3	Rear Roller Assembly 6
Replacement Seal Kit Assembly No. 106-6937 4	Replacement Seal Kit Assembly No. 107-1594 7
Shield, Bed Bar and Reel Assembly 5	Attachments and Accessories List 8

Part Description Abbreviations

Part descriptions in this catalog may include the following abbreviations.

AR. as required	HYD. hydraulic
ASM. assembly	INC. incorporated
CARR. carriage	LH. left hand
DEG. degrees	NI. nylon insert
FH. flat head	PPH. phillips pan head
GA. gauge	PTH. phillips truss head
HF. hex flange	PTO. power take off
HH. hex head	RH. right hand
HHF. hex head flange	SFH. slotted fillister head
HHFTF. hex head flange thread forming	SHH. slotted hex head
HJ. hex jam	SHWH. slotted hex washer head
HLH. hex lag head	SPH. slotted pan head
HOC. height-of-cut	SQH. square head
HS. hex	SRH. slotted round head
HSBH. hex socket button head	STD. standard
HSFH. hex socket flat head	TAP. self tapping
HS. hex socket head	TTH. torx truss head
HWH. hex washer head	WH. wing head
HWHTF. hex washer head thread forming	

Footnotes

❶ Not illustrated

❷ Not serviced separately

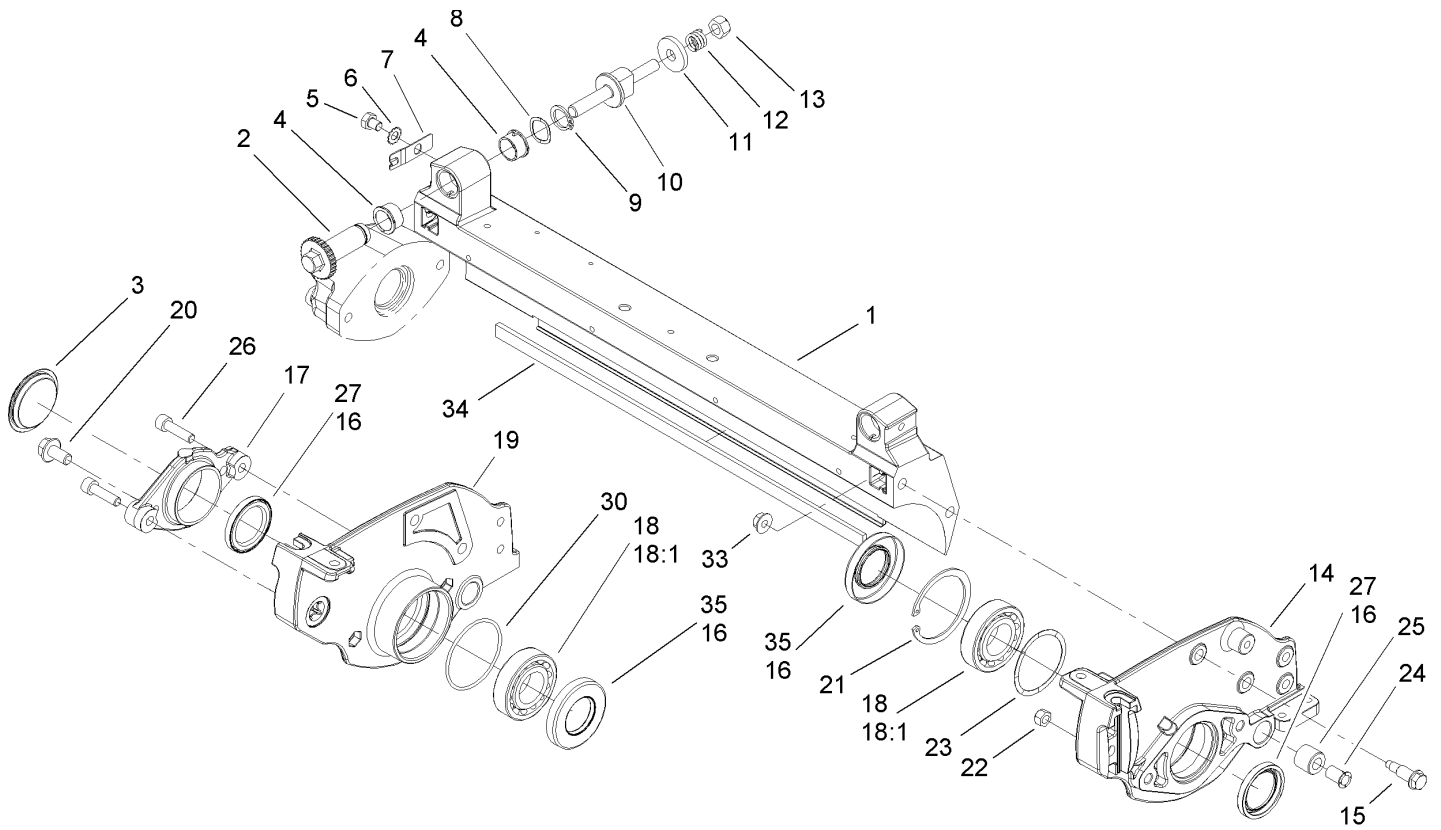

Frame Assembly

Ref	Part No.	Qty.	Description
1	105-5799	1	Frame
2	106-5363	2	Shaft-Adjuster
3	2410-30	1	Cap-Plastic
4	106-5344	4	Bushing-Flange, Keyed
5	33114-010	2	Screw-HH
6	3255-8	2	Washer-Lock
7	99-2097	2	Detent
8	106-5335	2	Washer-Wave
9	32120-93	2	Ring-Retaining
10	99-2096	2	Screw-Adjuster, Bedbar
11	99-2098	2	Washer
12	99-3755	2	Spring-Compression
13	33025-00	2	Nut-Lock
14	105-5795	1	Plate-Side, LH
15	105-5774	4	Bolt-Shoulder
16	106-6937	1	Seal Kit-Dpa Reel
17	104-9447	1	Adapter-Motor
18		2	Bearing-Packed, Grease
18:1	93-2489	1	Bearing
19	105-5797	1	Plate-Side, RH
20	106-2633	2	Screw-HHF
21	106-6914	1	Ring-Snap, Internal
22	33024-00	2	Nut-Lock
23	105-5700	1	Washer-Wave

Ref	Part No.	Qty.	Description
24	52-2890	2	Bushing-Nylon
25	63-9510	2	Bushing
26	94-3559	2	Screw-Sh
27	253-134	2	Seal-Grease
30	106-2607	1	O-Ring
33	98-0668	4	Nut
34	106-2619	1	Strip-Seal
35	106-6926	2	Seal-Grease

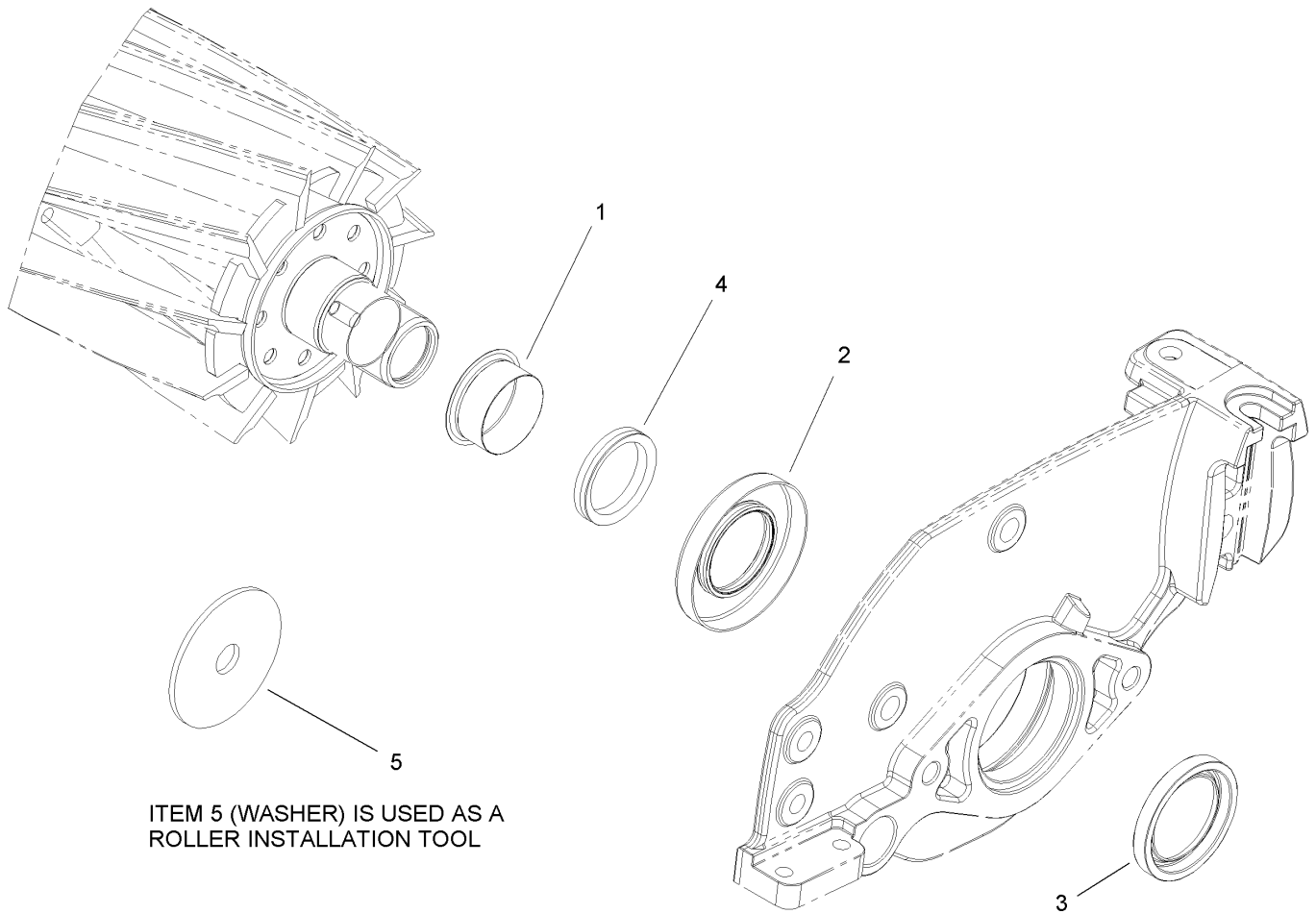

Replacement Seal Kit Assembly No. 106-6937

Ref	Part No.	Qty.	Description
1	106-6927	1	Sleeve-Speedi
2	106-6926	1	Seal-Grease
3	253-134	1	Seal-Grease
4	106-6929	1	V-Ring
5	104-0532	1	Washer-Pulley

--	--	--	--

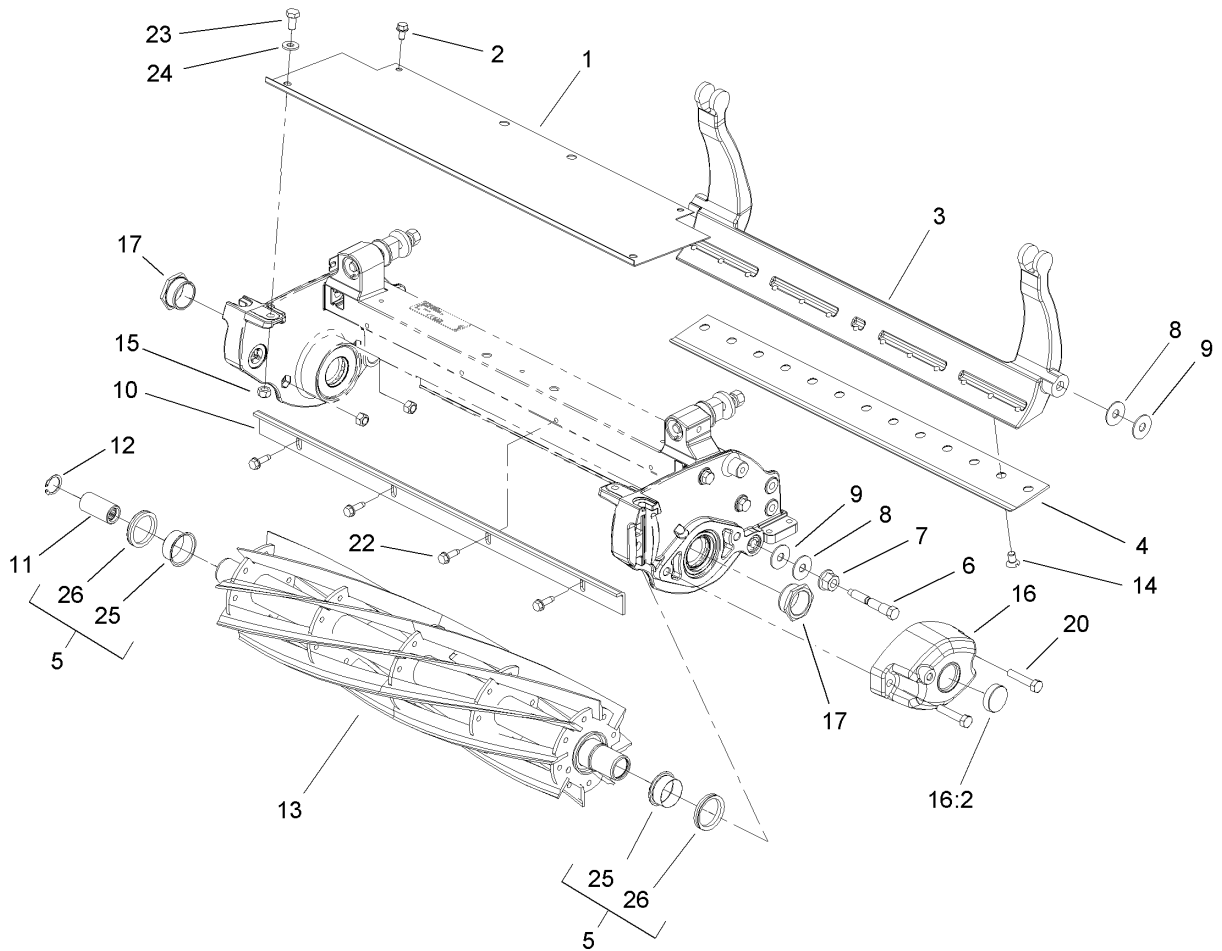

Shield, Bed Bar and Reel Assembly

Ref	Part No.	Qty.	Description
1	106-2600-01	1	Shield-Grass
2	104-2628	2	Screw-HWH
3	106-2648-01	1	Bedbar
④	93-4262	1	Bedknife-Microcut
4	93-4263	1	Bedknife-Tournament Cut
④	93-4264	1	Bedknife-Low Cut
5	106-6937	1	Seal Kit-Dpa Reel
6	65-6270	2	Bolt-Bedbar
7	32128-48	2	Nut-HHF
8	52-2860	4	Washer
9	52-2900	4	Washer-Plastic
10	106-6924-03	1	Bar-Cutoff
11	94-4507	1	Coupler-Splined
12	105-5775	1	Ring-Retaining
13	105-5792	1	11 Blade Reel ASM
14	57-4910	13	Screw-Special
15	33024-00	4	Nut-Lock
16	105-5709	1	Weight ASM
16:2	105-5708	1	Plug-Expansion
17	105-5706	2	Nut-Lock, Bearing
20	33114-040	2	Screw-HH
22	56-6380	4	Screw
23	33114-016	2	Screw-HH
24	3256-2	2	Washer-Flat

Ref	Part No.	Qty.	Description
25	106-6927	2	Sleeve-Speedi
26	106-6929	2	V-Ring

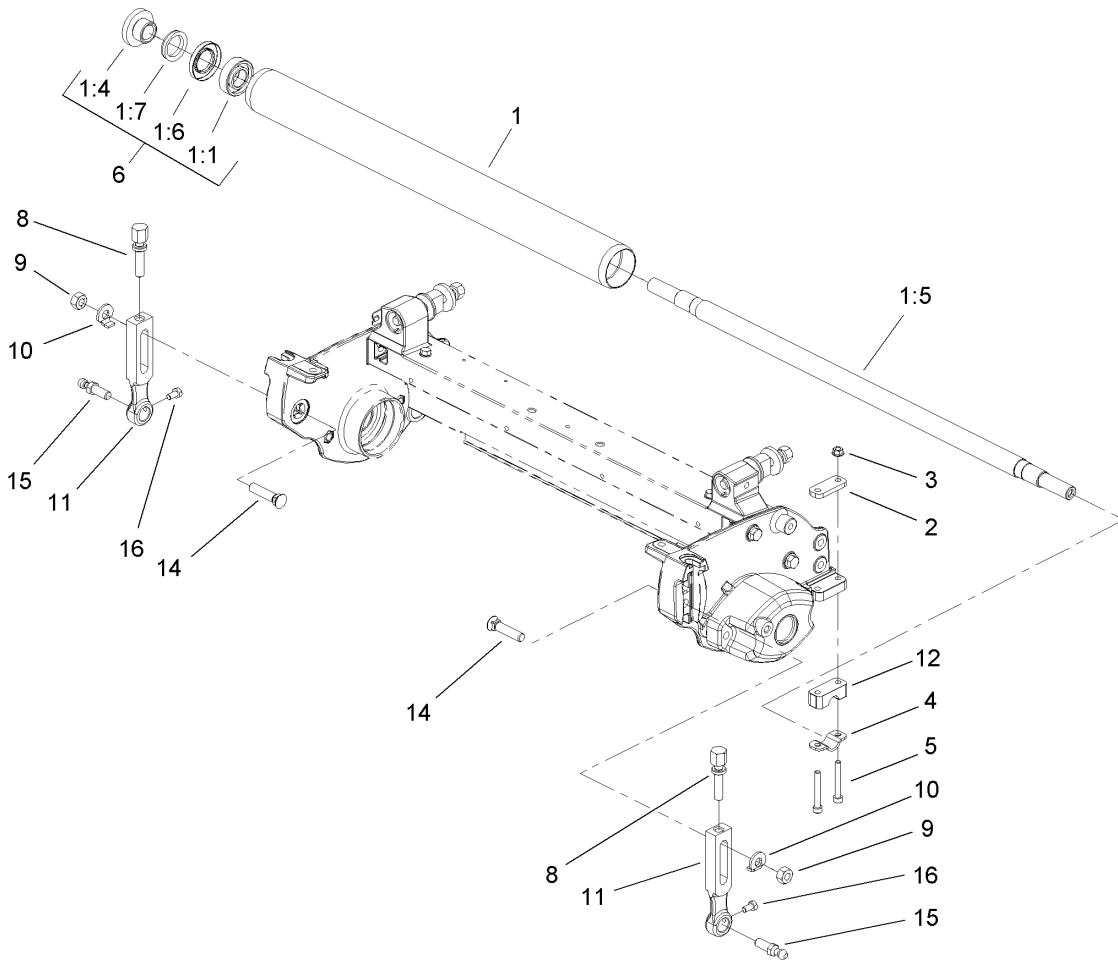

Rear Roller Assembly

Ref	Part No.	Qty.	Description
1	106-6945	1	Full Roller ASM
1:1	251-347	2	Bearing-Ball
1:4	108-3151	2	Nut-Lock, Bearing
1:5	106-6940	1	Shaft-Roller
1:6	106-6941	2	Seal
1:7	106-6942	2	V-Ring
2	105-5711	2	Shim-Roller
3	33003-00	4	Nut-HF
4	105-5712	2	Retainer-Shaft
5	106-2603	4	Screw-Sh
6	107-1594	1	Roller Rebuild Kit
8	106-2635	2	Screw-HOC
9	106-4668	2	Nut-Lock
10	104-2603	2	Washer-HOC
11	107-3502	2	Arm-HOC
12	105-5710	2	Spacer-Roller
14	105-5342	2	Bolt-Plow
15	94-2958	2	Stud-Ball
16	33113-012	2	Screw-HH

Attachments and Accessories

For 04611 - 11-Blade DPA Reel Mower, Greensmaster 3000 Series

Product Name	Model/Part
Wiehle Roller Kit	04424
Full Roller Kit	04625
Narrow Wiehle Roller Kit	04626
Wide Wiehle Roller Kit	04627
Steel Roller Kit	04628
DPA Reel Mower Groomer, Greensmaster 3150	04630
DPA Reel Mower Groomer, Greensmaster 3250-D	04631
DPA Reel Mower Rear Roller Brush, Greensmaster 3150-D and 3250-D	04640
DPA Reel Mower Rear Roller Brush, Greensmaster 3250-D	04641
DPA Reel Mower Rear Roller Scraper Kit	04646
Wiehle Roller Scraper Kit	106-4661
Wiehle Roller Scraper Kit	106-4662
Full Roller Scraper Kit	106-4663
Full Roller Scraper/Brush Kit	106-4664
High Height-of-Cut Kit, Greensmaster DPA and Flex 21 Reel Mowers	106-4699
Shim	106-6923
Replacement Seal Kit	106-6937
Extended Grass Shiled ASM	107-3503-01
Steel Roller ASM, Wiehle DPA	107-3510
Brush Kit	107-8125
Bedknife-Fairway	63-8600
Bedknife-Microcut	93-4262
Bedknife-Tournament Cut	93-4263
Bedknife-Low Cut	93-4264
Bedknife-Highcut	94-6392

NOTES

NOTES

NOTES

