



# Wheel Horse® XL 320 Lawn Tractor

Model No. 71209—Serial No. 250000001 and Up

**Operator's Manual**

This spark ignition system complies with Canadian ICES-002.

Ce système d'allumage par étincelle de véhicule est conforme à la norme NMB-002 du Canada.

# Contents

	<b>Page</b>
Introduction .....	2
Safety .....	3
Safe Operation Practices for Ride-on (Riding)	
Rotary Lawn Mowers .....	3
Toro Riding Mower Safety .....	5
Sound Pressure .....	5
Sound Power .....	5
Vibration .....	5
Slope Chart .....	7
Safety and Instruction Decals .....	9
Gasoline and Oil .....	12
Recommended Gasoline .....	12
Using Stabilizer/Conditioner .....	12
Filling the Fuel Tank .....	12
Checking the Engine Oil Level .....	12
Operation .....	13
Controls .....	13
Using the Parking Brake .....	13
Positioning the Seat .....	13
Using the Headlights .....	14
Using the Blade Control (PTO) .....	14
Setting the Height of Cut .....	14
Adjusting the Mower Wheels .....	14
Starting the Engine .....	14
Stopping the Engine .....	15
Using the Safety Interlock System .....	15
Testing the Safety Interlock System .....	16
Pushing the Tractor Manually .....	17
Driving Forward or Backward .....	17
Stopping the Tractor .....	17
Side Discharge or Mulch Grass .....	18
Installing the Discharge Cover .....	18
Operating Tips .....	19
Maintenance .....	20
Recommended Maintenance Schedule .....	20
Servicing the Engine Oil .....	21
Servicing the Battery .....	22
Servicing the Parking Brake .....	24
Greasing and Lubricating the Tractor .....	25
Servicing the Air Cleaner .....	25
Servicing the Spark Plug .....	26

	<b>Page</b>
Checking the Tire Pressure .....	27
Cleaning the Cooling System .....	27
Draining the Fuel Tank .....	27
Replacing the Fuel Filter .....	27
Servicing the Transaxle Fluid .....	28
Servicing the Fuse .....	28
Servicing the Headlights .....	28
Servicing the Blades .....	29
Removing the Mower .....	30
Installing the Mower .....	32
Replacing the Blade Drive Belt .....	33
Leveling the Mower from Side-to-Side .....	34
Adjusting the Front-to-Rear Blade Slope .....	34
Washing the Underside of the Mower .....	35
Cleaning and Storage .....	36
Wiring Diagram .....	38
Troubleshooting .....	39

# Introduction

Read this manual carefully to learn how to operate and maintain your product properly. The information in this manual can help you and others avoid injury and product damage. Although Toro designs and produces safe products, you are responsible for operating the product properly and safely.

You may contact Toro directly at [www.Toro.com](http://www.Toro.com) for product and accessory information, help finding a dealer, or to register your product.

Whenever you need service, genuine Toro parts, or additional information, contact an Authorized Service Dealer or Toro Customer Service and have the model and serial numbers of your product ready. Figure 1 illustrates the location of the model and serial numbers on the product.

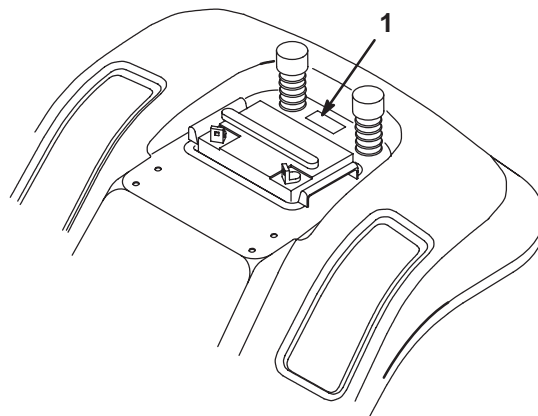

m-1856

**Figure 1**

1. Location of the model and serial numbers

Write the product model and serial numbers in the space below:

<b>Model No.</b> _____
<b>Serial No.</b> _____

This manual identifies potential hazards and has special safety messages that help you and others avoid personal injury and even death. **Danger**, **Warning**, and **Caution** are signal words used to identify the level of hazard. However, regardless of the hazard, be extremely careful.

**Danger** signals an extreme hazard that **will** cause serious injury or death if you do not follow the recommended precautions.

**Warning** signals a hazard that **may** cause serious injury or death if you do not follow the recommended precautions.

**Caution** signals a hazard that may cause minor or moderate injury if you do not follow the recommended precautions.

This manual uses 2 other words to highlight information.

**Important** calls attention to special mechanical information and **Note**: emphasizes general information worthy of special attention.

# Safety

## Safe Operation Practices for Ride-on (Riding) Rotary Lawn Mowers

**Read and understand the contents of this manual before operating the tractor.**

**▲ This is the safety alert symbol. It is used to alert you to potential personal injury hazards. Obey all safety messages that follow this symbol to avoid possible injury or death.**

The following instructions are from the CEN standard EN 836:1997.

This product is capable of amputating hands and feet and of throwing objects. Always follow all safety instructions to avoid serious injury or death.

### Training

- Read the instructions carefully. Be familiar with the controls and the proper use of the equipment.
- Never allow children or people unfamiliar with these instructions to use the lawnmower. Local regulations can restrict the age of the operator.

- Never mow while people, especially children, or pets are nearby.
- Keep in mind that the operator or user is responsible for accidents or hazards occurring to other people or their property.
- Do not carry passengers.
- All drivers should seek and obtain professional and practical instruction. Such instruction should emphasize:
  - the need for care and concentration when working with ride-on machines;
  - control of a ride-on machine sliding on a slope will not be regained by the application of the brake. The main reasons for loss of control are:
    - insufficient wheel grip;
    - being driven too fast;
    - inadequate braking;
    - the type of machine is unsuitable for its task;
    - lack of awareness of the effect of ground conditions, especially slopes;
    - incorrect hitching and load distribution.

### Preparation

- While mowing, always wear substantial footwear and long trousers. Do not operate the equipment when barefoot or wearing open sandals.
- Thoroughly inspect the area where the equipment is to be used and remove all objects which may be thrown by the machine.
- **Warning**—Fuel is highly flammable.
  - Store fuel in containers specifically designed for this purpose.
  - Refuel outdoors only and do not smoke while refuelling.
  - Add fuel before starting the engine. Never remove the cap of the fuel tank or add fuel while the engine is running or when the engine is hot.
  - If fuel is spilled, do not attempt to start the engine but move the machine away from the area of spillage and avoid creating any source of ignition until fuel vapors have dissipated.
  - Replace all fuel tanks and container caps securely.
- Replace faulty silencers.
- Before using, always visually inspect to see that the blades, blade bolts and cutter assembly are not worn or damaged. Replace worn or damaged blades and bolts in sets to preserve balance.

- On multi-bladed machines, take care as rotating one blade can cause other blades to rotate.

## Operation

- Do not operate the engine in a confined space where dangerous carbon monoxide fumes can collect.
- Mow only in daylight or in good artificial light.
- Before attempting to start the engine, disengage all blade attachment clutches and shift into neutral.
- Do not use on slopes of more than
  - 5° when mowing on side hills;
  - 10° when mowing uphill;
  - 15° when mowing downhill.
- Remember there is no such thing as a safe slope. Travel on grass slopes requires particular care. To guard against overturning:
  - do not stop or start suddenly when going up or downhill;
  - engage clutch slowly, always keep machine in gear, especially when travelling downhill;
  - machine speeds should be kept low on slopes and during tight turns;
  - stay alert for humps and hollows and other hidden hazards;
  - never mow across the face of the slope, unless the lawnmower is designed for this purpose.
- Use care when pulling loads or using heavy equipment.
  - Use only approved drawbar hitch points.
  - Limit loads to those you can safely control.
  - Do not turn sharply. Use care when reversing.
  - Use counterweight(s) or wheel weights when suggested in the instruction handbook.
- Watch out for traffic when crossing or near roadways.
- Stop the blades rotating before crossing surfaces other than grass.
- When using any attachments, never direct discharge of material toward bystanders nor allow anyone near the machine while in operation.
- Never operate the machine with damaged guards or without safety protective devices in place.
- Do not change the engine governor settings or overspeed the engine. Operating the engine at excessive speed can increase the hazard of personal injury.
- Before leaving the operator's position:

- disengage the power take-off and lower the attachments;
- change into neutral and set the parking brake;
- stop the engine and remove the key.

- Disengage drive to attachments, stop the engine, and disconnect the spark plug wire(s) or remove the ignition key
  - before clearing blockages or unclogging chute;
  - before checking, cleaning or working on the lawnmower;
  - after striking a foreign object. Inspect the lawnmower for damage and make repairs before restarting and operating the equipment;
  - if the machine starts to vibrate abnormally (check immediately).
- Disengage drive to attachments when transporting or not in use.
- Stop the engine and disengage drive to attachment
  - before refuelling;
  - before removing the grass catcher;
  - before making height adjustment unless adjustment can be made from the operator's position.
- Reduce the throttle setting during engine run-out and, if the engine is provided with a shut-off valve, turn the fuel off at the conclusion of mowing.

## Maintenance and Storage

- Keep all nuts, bolts and screws tight to be sure the equipment is in safe working condition.
- Never store the equipment with fuel in the tank inside a building where fumes can reach an open flame or spark.
- Allow the engine to cool before storing in any enclosure.
- To reduce the fire hazard, keep the engine, silencer, battery compartment and fuel storage area free of grass, leaves, or excessive grease.
- Check the grass catcher frequently for wear or deterioration.
- Replace worn or damaged parts for safety.
- If the fuel tank has to be drained, this should be done outdoors.
- On multi-bladed machines, take care as rotating one blade can cause other blades to rotate.
- When machine is to be parked, stored or left unattended, lower the cutting means unless a positive mechanical lock is used.

# Toro Riding Mower Safety

The following paragraph contains safety information specific to Toro products that is not included in the CEN standard.

Use only Toro-approved attachments. The warranty may be voided if you use the tractor with unapproved attachments.

## Sound Pressure

This unit has a maximum sound pressure level at the operator's ear of 86 dBA, based on measurements of identical machines per Directive 98/37/EC.

## Sound Power

This unit has a guaranteed sound power level of 100 dBA, based on measurements of identical machines per Directive 2000/14/EC.

## Vibration

This unit does not exceed a hand/arm vibration level of  $5.39 \text{ m/s}^2$ , based on measurements of identical machines per Directive 98/37/EC.

This unit does not exceed a whole body vibration level of  $0.27 \text{ m/s}^2$ , based on measurements of identical machines per Directive 98/37/EC.



# Slope Chart

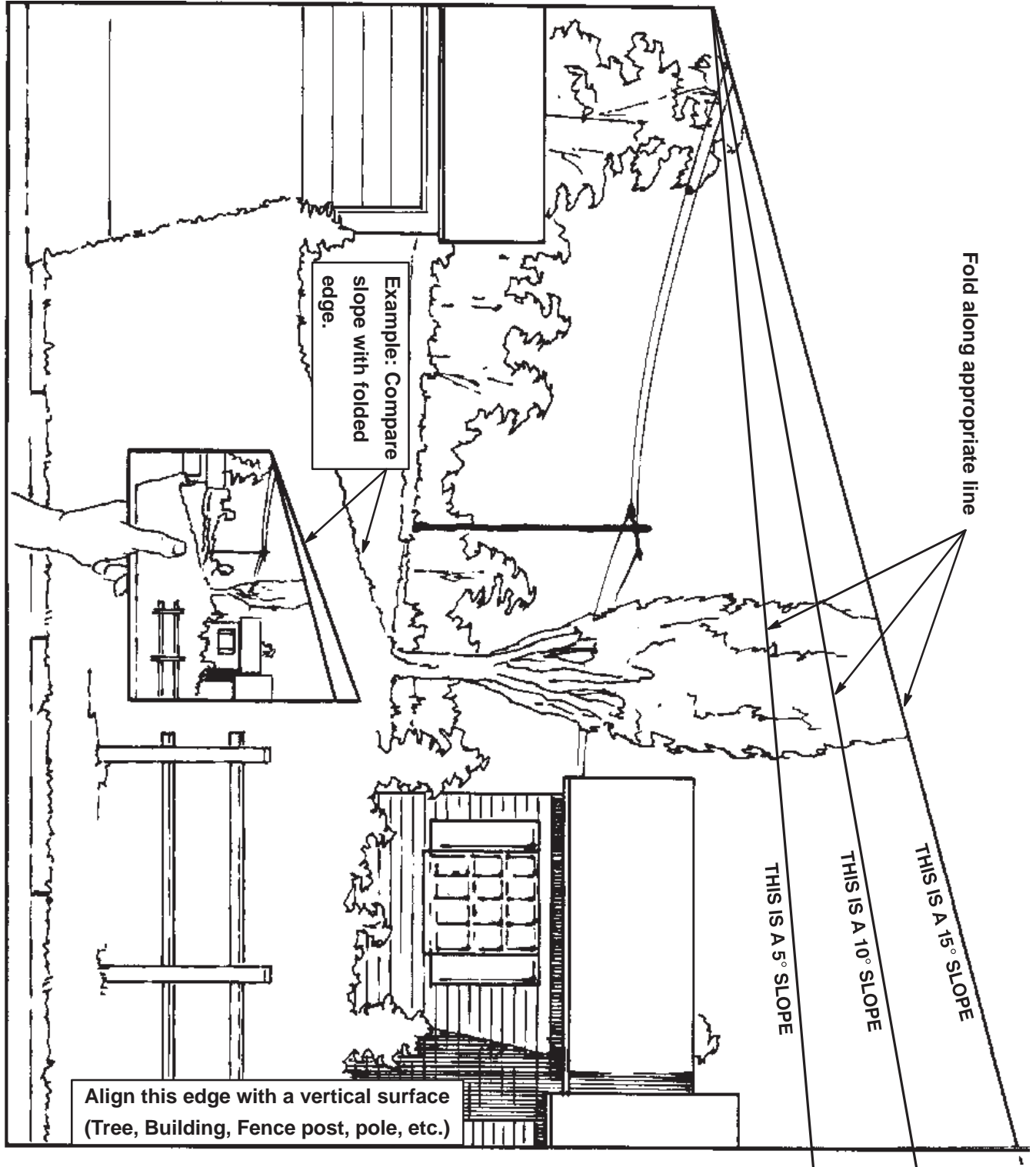



# Safety and Instruction Decals



Safety decals and instructions are easily visible to the operator and are located near any area of potential danger. Replace any decal that is damaged or lost.

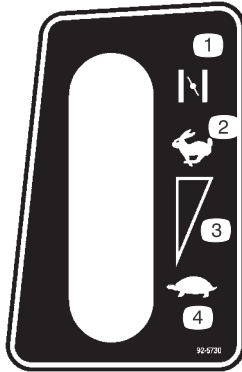

92-5730

- 1. Choke
- 2. Fast
- 3. Continuous variable setting
- 4. Slow

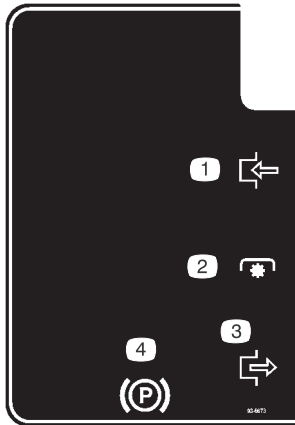

93-6673

- 1. Engage
- 2. Power take-off (PTO)
- 3. Disengage
- 4. Parking brake



93-6674

- 1. Crushing hazard, hand—read the instructions before servicing or performing maintenance.



93-6675

- 1. Parking brake—to engage, press the brake/clutch pedal and lift the parking brake lever; to disengage press and release the brake/clutch pedal.
- 2. Brake and clutch—to engage, press the brake/clutch pedal.
- 3. Fast
- 4. Continuous variable setting
- 5. Slow
- 6. Warning—read the *Operator's Manual*.
- 7. Warning—to avoid tipping the tractor, do not drive across slopes greater than 5 degrees, up slopes greater than 10 degrees, or down slopes greater than 15 degrees.
- 8. Thrown object hazard—keep bystanders a safe distance from the machine.
- 9. Thrown object hazard, mower—keep the deflector in place.
- 10. Cutting/dismemberment hazard of hand or foot, mower blade—stay away from moving parts.
- 11. Crushing/dismemberment of a bystander—keep bystanders a safe distance from the machine.



**93-7009**

1. Warning—do not operate the mower with the deflector up or removed; keep the deflector in place.
2. Cutting/dismemberment hazard of hand or foot, mower blade—stay away from moving parts.



**93-7010**

1. Thrown object hazard—stay a safe distance from the machine.
2. Thrown object hazard, mower—keep the deflector in place.
3. Cutting/dismemberment of hand or foot—stay away from moving parts.



**99-2986**

1. Crushing/dismemberment hazard of bystanders—do not turn the key while children are present; keep children a safe distance from the machine.



**99-5340**

1. KeyChoice—turn to enable reverse mowing.

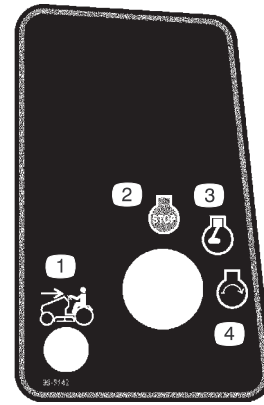

**99-8142**

- |                              |                 |
|------------------------------|-----------------|
| 1. Mowing in reverse enabled | 3. Engine—run   |
| 2. Engine—stop               | 4. Engine—start |

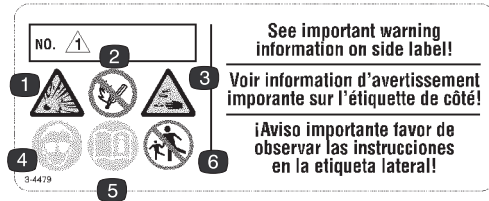

**104-4163**

- |  |  |
|--|--|
| 1. Explosion hazard                    | 4. Wear eye protection                               |
| 2. No fire, open flames, or smoking.   | 5. Read the <i>Operator's Manual</i> .               |
| 3. Caustic liquid/chemical burn hazard | 6. Keep bystanders a safe distance from the battery. |

**MAINTENANCE FREE • SANS ENTRETIEN • LIBRE DE MANTENIMIENTO**

NIVEAU MAXIMUM      MAXIMUM FILL      CAPACIDAD MAXIMA  
 NIVEAU MINIMUM      MINIMUM FILL      CAPACIDAD MINIMA

7      8

---

**! DANGER/POISON ¡PELIGRO/VENENO!**



1. Contains lead, —do not throw the battery in the garbage.

2. Recycle

<p>3. <b>SHIELD EYES. EXPLOSIVE GASES CAN CAUSE BLINDNESS OR INJURY.</b></p> <p><b>PROTÉGER LES YEUX. GAZ EXPLOSIFS PEUVENT RENDRE AVEUGLE OU PROVOQUER DES LÉSIONS.</b></p> <p><b>PROTEJA LOS OJOS. GASES EXPLOSIVOS PUEDEN CAUSAR CEGUERA O DAÑO.</b></p>	<p>4. <b>NO</b></p> <ul style="list-style-type: none"> <li>• SPARKS</li> <li>• FLAMES</li> <li>• SMOKING</li> </ul> <p><b>ÉLOIGNER</b></p> <ul style="list-style-type: none"> <li>• ÉTINCELLES</li> <li>• FLAMMES</li> <li>• CIGARETTES</li> </ul> <p><b>NO</b></p> <ul style="list-style-type: none"> <li>• CHISPAS</li> <li>• FLAMAS</li> <li>• FUMAR</li> </ul>	<p>5. <b>SULFURIC ACID CAN CAUSE BLINDNESS OR SEVERE BURNS.</b></p> <p><b>ACIDE SULFURIQUE PEUT RENDRE AVEUGLE OU PROVOQUER DES BRULURES GRAVES.</b></p> <p><b>ACIDO SULFURICO PUEDE CAUSAR CEGUERA O QUEMADURAS SEVERAS.</b></p>	<p>6. <b>FLUSH EYES IMMEDIATELY WITH WATER. GET MEDICAL HELP FAST.</b></p> <p><b>RINCER IMMEDIATEMENT LES YEUX A GRANDE EAU. CONTACTER RAPIDEMENT UN MEMBRE DE LA PROFESSION MEDICALE.</b></p> <p><b>LAVE LOS OJOS DE INMEDIATO. CONSIGA AYUDA MEDICA RAPIDO.</b></p>
---	--	---	---

**KEEP OUT OF THE REACH OF CHILDREN. DO NOT TIP. DO NOT OPEN BATTERY!**

**MAINTENIR HORS DE LA PORTÉE DES ENFANTS. NE RENVÉRSEZ PAS. N'OUVREZ PAS LA BATTERIE!**

**MANTENGASE FUERA DEL ALCANCE DE LOS NIÑOS. NO INCLINE. NO ABRA LA BATERIA!**

**HOW TO ACTIVATE DRY CHARGED BATTERIES**

1. Use only battery electrolyte (1.265 Sp. Gr.) to fill battery initially.
2. Do not overfill. Let stand for 15 minutes.
3. Charge battery at 4-5 amps until specific gravity is 1.250 or higher and temperature is at least 60°F. — all cells gassing freely.
4. After battery has been activated, add only water to replace normal loss.

3-4806    Dist. by:/por:/par: The Toro Company, Bloomington, MN 55420    MADE IN U.S.A. • FABRIQUE AUX É.U.A. • HECHO EN E.U.A.

104-4164

- |  |   |  |   |
|--|---|--|---|
| <ol style="list-style-type: none"> <li>1. Contains lead,—do not throw the battery in the garbage.</li> <li>2. Recycle</li> </ol> | <ol style="list-style-type: none"> <li>3. Wear eye protection—explosive gases can cause blindness and other injuries.</li> <li>4. No sparks, flame, or smoking</li> </ol> | <ol style="list-style-type: none"> <li>5. Sulfuric acid can cause blindness or severe burns.</li> <li>6. Flush eyes immediately with water and get medical help fast.</li> </ol> | <ol style="list-style-type: none"> <li>7. Maximum fill line</li> <li>8. Minimum fill line</li> <li>9. Instructions for activating the battery.</li> </ol> |
|--|---|--|---|

# Gasoline and Oil

## Recommended Gasoline

Use unleaded regular gasoline suitable for automotive use (85 pump octane minimum). You may use leaded regular gasoline if unleaded regular is not available.

**Important** Never use methanol, gasoline containing methanol, or gasohol containing more than 10% ethanol because the fuel system could be damaged. Do not mix oil with gasoline.



### Danger



In certain conditions, gasoline is extremely flammable and highly explosive. A fire or explosion from gasoline can burn you and others and can damage property.

- Fill the fuel tank outdoors in an open area when the engine is cold. Wipe up any gasoline that spills.
- Do not fill the fuel tank completely full. Add gasoline to the fuel tank until the level is 1/4 to 1/2 in. (6 to 13 mm) below the bottom of the filler neck. This empty space in the tank allows the gasoline to expand.
- Never smoke when handling gasoline, and stay away from an open flame or where a spark may ignite the gasoline fumes.
- Store gasoline in an approved container and keep it out of the reach of children.
- Never buy more than a 30-day supply of gasoline.
- Always place gasoline containers on the ground away from your vehicle before filling.
- Do not fill gasoline containers inside a vehicle or on a truck or trailer bed because interior carpets or plastic truck bed liners may insulate the container and slow the loss of any static charge.
- When practical, remove gas-powered equipment from the truck or trailer and refuel the equipment with its wheels on the ground.
- If this is not possible, refuel such equipment on a truck or trailer from a portable container, not from a gasoline dispenser nozzle.
- If you must use a gasoline dispenser, keep the nozzle in contact with the rim of the fuel tank or container opening at all times until fueling is complete.

## Using Stabilizer/Conditioner

Use a fuel stabilizer/conditioner in the tractor to provide the following benefits:

- It keeps gasoline fresh during storage for up to 90 days. For longer storage, drain the fuel tank.
- It cleans the engine while it runs.
- It eliminates gum-like varnish buildup in the fuel system, which causes hard starting.

**Important** Do not use fuel additives containing methanol or ethanol.

Add the correct amount of fuel stabilizer/conditioner to the gasoline.

**Note:** A fuel stabilizer/conditioner is most effective when it is mixed with fresh gasoline. To minimize the chance of varnish deposits in the fuel system, use a fuel stabilizer/conditioner at all times.

## Filling the Fuel Tank

1. Stop the engine and wait for all moving parts to stop.
2. Set the parking brake.
3. Clean around the fuel tank cap and remove the cap.
4. Add unleaded regular gasoline to the fuel tank until the level is 1/4 to 1/2 in. (6 to 13 mm) below the bottom of the filler neck. **Do not fill the fuel tank completely full.**  
**Note:** This space in the tank allows gasoline to expand.
5. Install the fuel tank cap securely.
6. Wipe up any gasoline that spills.

## Checking the Engine Oil Level

Before you start the engine and use the tractor, check the oil level in the engine crankcase; refer to Checking the Oil Level on page 21.

# Operation

**Note:** Determine the left and right sides of the tractor from the normal operating position.

## Controls

Become familiar with the controls (Fig. 2) before you start the engine and operate the tractor.

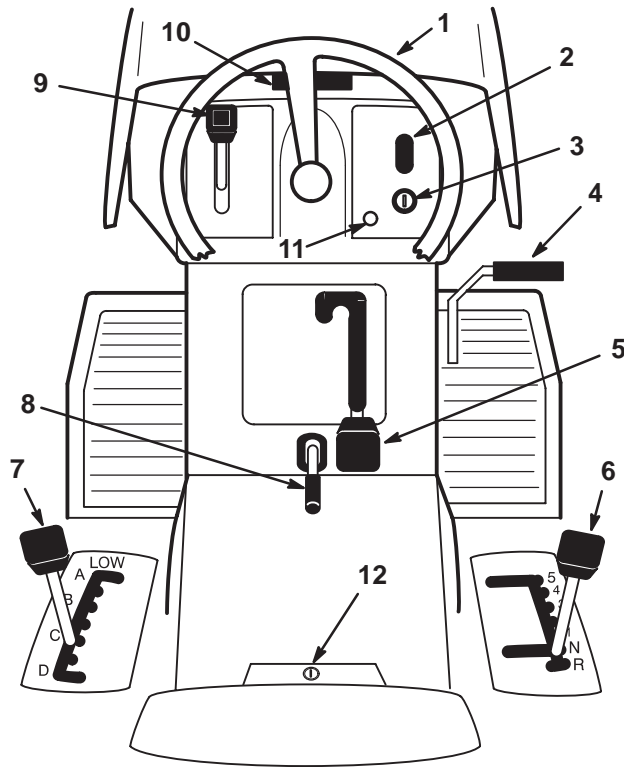

**Figure 2**

- |                                   |                                |
|-----------------------------------|--------------------------------|
| 1. Steering wheel                 | 7. Height-of-cut lever         |
| 2. Light switch—on/off (optional) | 8. Parking brake lever         |
| 3. Ignition switch                | 9. Throttle lever              |
| 4. Clutch/brake pedal             | 10. Hood opening               |
| 5. Blade control (PTO) lever      | 11. Operating-in-reverse light |
| 6. Ground speed lever             | 12. KeyChoice® switch          |

## Using the Parking Brake

Always set the parking brake whenever you stop the tractor or leave it unattended.

### Setting the Parking Brake

1. Push the clutch/brake pedal (Fig. 3) down and hold it.

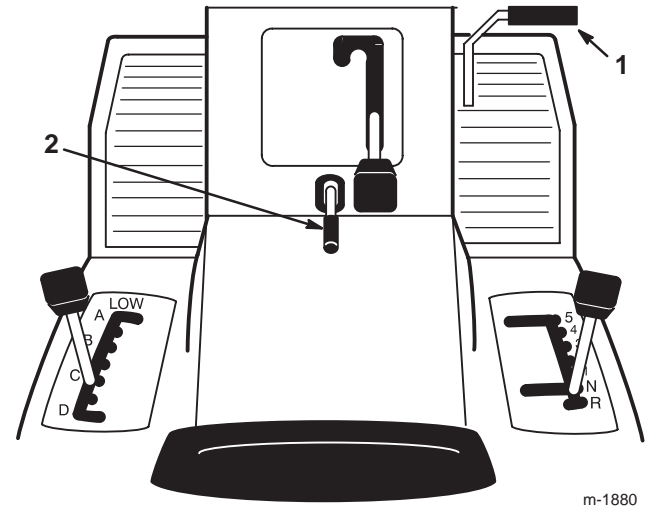

**Figure 3**

1. Clutch/brake pedal
2. Parking brake lever

2. Lift the parking brake lever (Fig. 3) up and gradually take your foot off of the clutch/brake pedal.

**Note:** The clutch/brake pedal should stay in the depressed (locked) position.

### Releasing the Parking Brake

1. Push down on the clutch/brake pedal (Fig. 3).  
**Note:** The parking brake lever should release.
2. Gradually release the clutch/brake pedal.

## Positioning the Seat

The seat can move forward and backward. Position the seat where you have the best control of the tractor and are most comfortable.

1. Raise the seat and loosen the adjustment knobs (Fig. 4).

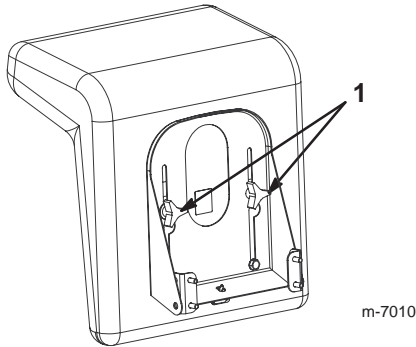

Figure 4

1. Adjustment knobs

2. Move the seat to the desired position and tighten the knobs.

## Using the Blade Control (PTO)

The blade control (PTO) lever engages and disengages power to the blade.

### Engaging the Blade

1. Depress the clutch/brake pedal to stop the tractor.
2. Shift the blade control (PTO) lever to Engage (Fig. 5).

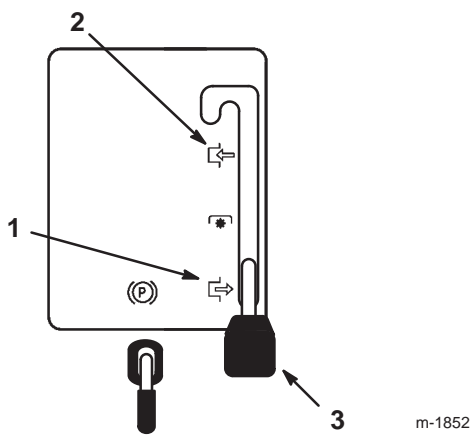

Figure 5

1. Disengage
2. Engage
3. Blade control (PTO) lever

### Disengaging the Blade

1. Depress the clutch/brake pedal to stop the tractor.
2. Shift the blade control (PTO) lever to Disengage (Fig. 5).

## Setting the Height of Cut

Use the height-of-cut lever to raise and lower the mower to the desired cutting height. You can set the cutting height to 7 different positions from approximately 1 to 4 in. (25 to 102 mm).

Pull on the height-of-cut lever and shift it into the desired position (Fig. 6).

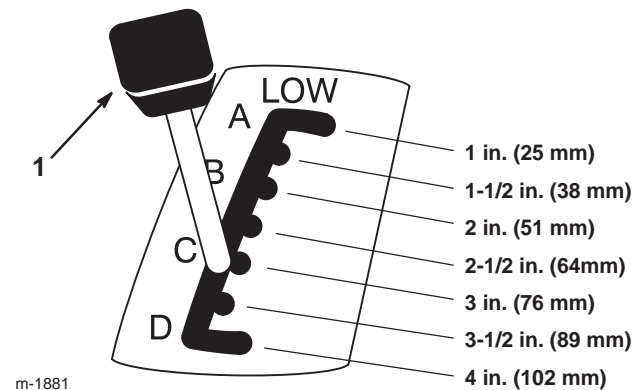

Figure 6

1. Height-of-cut lever

## Starting the Engine

1. Sit down on the seat.
2. Set the parking brake; refer to Setting the Parking Brake on page 13.

**Note:** The engine does not start unless you set the parking brake or fully depress the clutch/brake pedal.

3. Shift the ground speed lever into Neutral (Fig. 7).

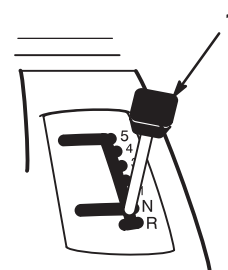
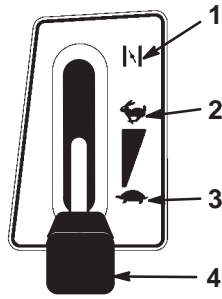

Figure 7

1. Ground speed lever

4. Shift the blade control (PTO) lever to Disengage (Fig. 5).
5. Shift the throttle lever to Choke (Fig. 8).



**Figure 8**

m-1859

- |          |                   |
|----------|-------------------|
| 1. Choke | 3. Slow           |
| 2. Fast  | 4. Throttle lever |

**Note:** An engine that has been running and is warm may not require step 5.

6. Turn the ignition key clockwise and hold it in the Start position (Fig. 9). When the engine starts, release the key.

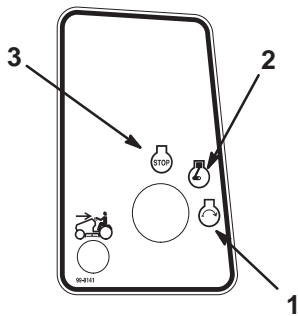

**Figure 9**

- |          |        |
|----------|--------|
| 1. Start | 3. Off |
| 2. On    |        |

**Important** If the engine does not start after 30 seconds of continuous cranking, turn the ignition key to Off and let the starter motor cool; refer to Troubleshooting on page 39.

7. After the engine starts, slowly shift the throttle lever to Fast (Fig. 8). If the engine stalls or hesitates, shift the throttle lever back to Choke for a few seconds and then shift the throttle lever to Fast. Repeat this step as required.

## Stopping the Engine

1. Shift the throttle lever to Slow (Fig. 8).
2. Turn the ignition key to Off (Fig. 9).
3. Remove the ignition key.

## Using the Safety Interlock System

⚠
Caution
⚠

If the safety interlock switches are disconnected or damaged, the tractor could operate unexpectedly, causing personal injury.

- Do not tamper with the interlock switches.
- Check the operation of the interlock switches daily and replace any damaged switches before operating the tractor.
- Replace switches every 2 years regardless of whether they are operating properly or not.

## Understanding the Safety Interlock System

The safety interlock system is designed to prevent the engine from starting unless:

- The clutch/brake pedal is depressed.
- The blade control (PTO) lever is in the Disengage position.

The safety interlock system stops the engine if you rise from the seat when you release the clutch/brake pedal or engage the blade.

## Setting the KeyChoice® Switch to Operate in Reverse

The interlock feature on the tractor prevents the power take-off (PTO) from operating when you back up the tractor. If you shift the ground speed lever into Reverse with the PTO engaged (i.e., with the mower blades or other attachment running), the engine will stop. **Do not mow in reverse unless it is absolutely necessary.**

If you need to use the PTO while backing up, turn off the interlock feature using the KeyChoice switch located near the seat bracket (Fig. 10).

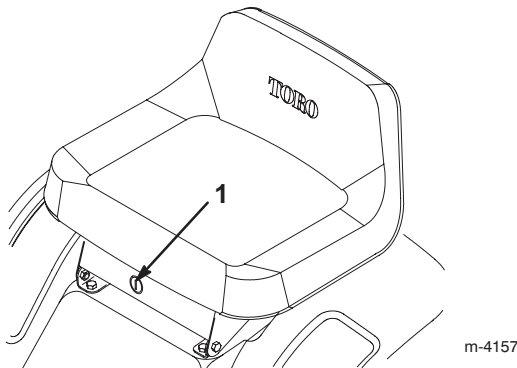

Figure 10

1. KeyChoice switch

3. Turn the KeyChoice key.

A red light on the front console (Fig. 11) turns on, indicating that the interlock is disabled.

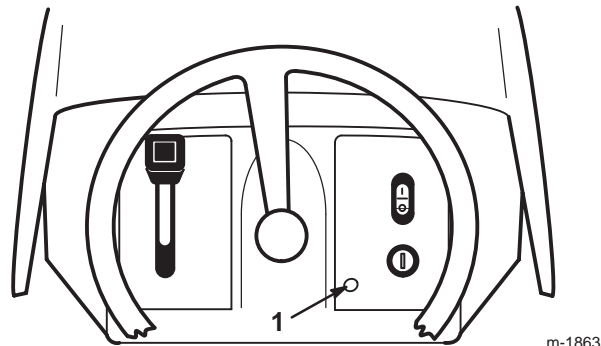

Figure 11

1. Operating-in-reverse light

4. Shift the ground speed lever into Reverse and complete your task.
5. Disengage the blade (PTO) to activate the interlock.
6. Remove the KeyChoice key and put it in a safe place out of the reach of children.

## Testing the Safety Interlock System

### **Danger**

You could back over a child or bystander while the mower blade or other attachment is engaged and cause serious injury or death.

- Do not mow in reverse unless it is absolutely necessary.
- Do not insert the KeyChoice key unless it is absolutely necessary.
- Always look backward and down before backing up the tractor.
- Use the KeyChoice switch only if you are certain that no children or other bystanders will enter the mowing area.
- Be very observant after deactivating the interlock because the sound of the engine may prevent you from noticing that a child or bystander has entered the work area.
- Always remove both the ignition and KeyChoice keys and put them in a safe place out of the reach of children or unauthorized users when you leave the tractor unattended.

1. Engage the blade (PTO).
2. Insert the KeyChoice key into the switch (Fig. 10).

### **Caution**

If the safety interlock switches are disconnected or damaged, the tractor could operate unexpectedly, causing personal injury.

- Do not tamper with the interlock switches.
- Check the operation of the interlock switches daily and replace any damaged switches before operating the tractor.

Test the safety interlock system before you use the tractor each time. If the safety interlock system does not operate as described below, have an Authorized Service Dealer repair the safety interlock system immediately. While sitting in the seat, perform the following checks:

1. Shift the ground speed lever into Neutral, set the parking brake, shift the blade control (PTO) lever to Engage, and turn the ignition key to Start: The engine should not crank.
2. With the ground speed lever in Neutral, shift the blade control (PTO) lever to the Disengage position, release the parking brake, and turn the ignition key to Start: The engine should not crank.

3. With the ground speed lever in Neutral, set the parking brake, shift the blade control (PTO) lever to Disengage, and start the engine. While the engine is running, release the parking brake and rise slightly from the seat: The engine should stop.
4. Shift the blade control (PTO) lever into the Disengage position, shift the ground speed lever in Neutral, set the parking brake, and start the engine. While the engine is running, shift the blade control (PTO) lever into the Engage position, push in the clutch, and shift the ground speed lever in Reverse: The engine should stop.
5. Shift the blade control (PTO) lever into the Disengage position, shift the ground speed lever in Neutral, and set the parking brake. Start the engine, shift the blade control (PTO) lever into the Engage position, and turn the KeyChoice key and release it: The operating-in-reverse warning light should illuminate.
6. Shift the blade control (PTO) lever to the Disengage position: The operating-in-reverse warning light should turn off.

## Driving the Tractor Forward or Backward

The throttle control regulates the engine speed as measured in RPM (revolutions per minute).

To go forward or backward:

1. Depress the clutch/brake pedal.
2. Shift the ground speed lever to the desired forward speed or to Reverse.

**Note:** As you slowly release the pedal, the tractor will begin to move.

3. Steer the tractor with the steering wheel.

**Note:** To operate the tractor in reverse with the blade (PTO) engaged, you must deactivate the operating-in-reverse interlock using the KeyChoice switch located in front of and below the seat.



### Caution



**Suddenly releasing the clutch pedal could cause you to lose control and suddenly put the tractor in motion.**

**Always release the clutch pedal slowly when starting the tractor in motion.**

## Selecting the Ground Speed

**Important** To avoid transmission damage, always depress the clutch/brake pedal before shifting into or out of Reverse.

Always start the tractor in motion by depressing the clutch/brake pedal and shifting into the desired speed. Once the tractor is in motion, you can shift into any forward speed without depressing the clutch/brake pedal. In most conditions, the tractor is powerful enough to move out in any speed. If it will not move out in a higher speed because of a heavy load, shift to a lower speed.

**Important** Do not shift on slopes. Choose a slow speed so that you will not have to stop or shift while on the slope.

## Stopping the Tractor

1. Depress the clutch/brake pedal.
2. Shift the ground speed lever into Neutral.
3. Disengage the blade (PTO).
4. Turn the ignition key to Off.
5. Set the parking brake if you leave the tractor unattended; refer to Setting the Parking Brake on page 13.

**Note:** Remove the keys from the ignition and KeyChoice switches.



## Caution



Children or bystanders may be injured if they move or attempt to operate the tractor while it is unattended.

Always remove the ignition and KeyChoice keys and set the parking brake when leaving the tractor unattended, even if just for a few minutes.

**Important** To prevent excessive wear, do not “ride the brakes.” Shift the ground speed lever to a lower speed so that you will not have to stop or shift while you are on the slope.

## Side Discharging or Mulching the Grass



## Danger



Without the grass deflector, discharge cover, or complete grass catcher assembly mounted in place, you and others are exposed to blade contact and thrown debris. Contact with a rotating mower blade and thrown debris will cause injury or death.

- Never remove the grass deflector from the mower because the grass deflector routes material down toward the turf. If the grass deflector is ever damaged, replace it immediately.
- Never put your hands or feet under the mower.
- Never try to clear discharge area or mower blades unless you disengage the blade (PTO) and rotate the ignition key to Off. Also, remove the key and disconnect the wire from the spark plug.

The mower has a hinged grass deflector that disperses clippings to the side and down toward the turf.

To mulch the grass clippings, you must install the discharge cover into the opening in the side of the mower; refer to Installing the Discharge Cover on page 18.

## Installing the Discharge Cover

To convert from a side discharge to a mulching mower, install the discharge cover into the opening at the side of the mower.

1. Stop the engine and wait for all moving parts to stop.
2. Remove the ignition key.
3. Lift the grass deflector and place the discharge cover over the opening onto the lower lip of the mower and slide it into the front hinge (Fig. 12).

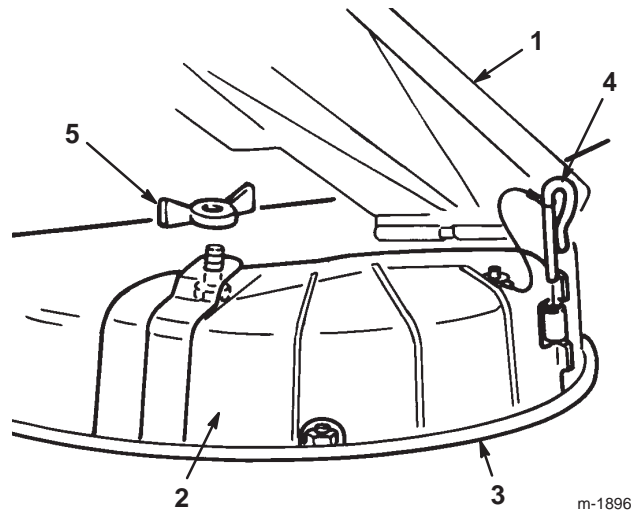

m-1896

Figure 12

- |                    |              |
|--------------------|--------------|
| 1. Grass deflector | 4. Hinge pin |
| 2. Discharge cover | 5. Wing nut  |
| 3. Lower lip       |              |
4. Slide the hinge pin through the hinge (Fig. 12).
  5. Secure the discharge cover to the mower with the wing nut (Fig. 12).
  6. To convert back to a side discharge mower, remove the discharge cover and lower the grass deflector over the discharge opening.

## Operating Tips

- For the best performance, operate the engine at the maximum speed. The mower requires air to thoroughly cut grass clippings, so do not set the height-of-cut too low or completely surround the mower in uncut grass. Always leave one side of the mower free from uncut grass to allow the air to be drawn into the mower.
- Cut the grass slightly longer than normal to ensure that the cutting height of the mower does not scalp any uneven ground. When cutting grass longer than 6 in. (15 cm) tall, cut the lawn twice to ensure an acceptable appearance.
- It is best to cut only about 1/3 of the grass blade. Do not cut more than that unless the grass is sparse or it is late fall when grass grows more slowly.
- Alternate the mowing direction to keep the grass standing straight. This also helps disperse clippings and enhances decomposition and fertilization.
- Grass grows at different rates at different times of the season. To maintain the same cutting height, which is a good practice, mow more often in early spring. As the grass growth rate slows in mid summer, mow less frequently.
- If the grass is longer than normal, or if it contains a high degree of moisture, raise the cutting height higher than usual, cut the grass at that setting, and then cut the grass again at the lower, normal setting.
- If you must stop the tractor while mowing, you may leave a clump of grass clippings on your lawn. To avoid this, do the following:
  - Engage the blade and move to a previously cut area.
  - Disperse the clippings evenly by raising the mower 1 or 2 height-of-cut settings while driving forward with the blade engaged.
- Use the washout port to clean clippings and dirt from the underside of the mower after each use. If grass and dirt build up inside the mower, the cutting quality will eventually become unsatisfactory.
- Maintain a sharp blade throughout the season. A sharp blade cuts grass cleanly without tearing or shredding the grass blades. Tearing and shredding the grass turns it brown at the edges, which slows its growth and increases the chance of disease. Every 30 days, check the blade for sharpness and file down any nicks.

# Maintenance

**Note:** Determine the left and right sides of the tractor from the normal operating position.

## Recommended Maintenance Schedule

Maintenance Service Interval	Maintenance Procedure
Each use	<ul style="list-style-type: none"> <li>• Check the engine oil level.</li> <li>• Check the safety interlock system.</li> <li>• Clean the mower housing.</li> </ul>
Every 5 hours	<ul style="list-style-type: none"> <li>• Check the brakes.</li> <li>• Check the cutting blade.</li> </ul>
Every 25 hours	<ul style="list-style-type: none"> <li>• Grease the chassis.<sup>1</sup></li> <li>• Service the foam air cleaner.<sup>1</sup></li> <li>• Check the spark plug.</li> <li>• Check the tire pressure.</li> </ul>
Every 50 hours	<ul style="list-style-type: none"> <li>• Change the engine oil.<sup>2</sup></li> <li>• Check the battery electrolyte.</li> </ul>
Every 100 hours	<ul style="list-style-type: none"> <li>• Service the paper air cleaner.<sup>1</sup></li> <li>• Replace the spark plug.</li> <li>• Replace the fuel filter.</li> <li>• Clean the cooling system.<sup>1</sup></li> </ul>
Before storage	<ul style="list-style-type: none"> <li>• Perform all of the maintenance procedures listed above.</li> <li>• Check the belts for wear/cracks.</li> <li>• Drain the fuel tank.</li> <li>• Paint chipped surfaces.</li> <li>• Charge the battery and disconnect the cables.</li> </ul>
After storage	<ul style="list-style-type: none"> <li>• Check the safety interlock system.</li> <li>• Check the brakes.</li> <li>• Check the spark plug.</li> <li>• Check the battery electrolyte.</li> <li>• Check the tire pressure.</li> </ul>

<sup>1</sup>Grease the chassis more often in dusty, dirty conditions.

<sup>2</sup>Change the engine oil after the first 5 operating hours; change it more often than recommended when operating the engine under a heavy load or in high temperatures.

**Important** Refer to your engine operator's manual for additional maintenance procedures.

Caution

**If you leave the key in the ignition switch, someone could accidentally start the engine and seriously injure you or other bystanders.**

**Remove the key from the ignition and disconnect the wire from the spark plug before you do any maintenance. Set the wire aside so that it does not accidentally contact the spark plug.**

# Servicing the Engine Oil

Check the oil level daily or after every 8 hours.

Change the oil after the first 5 operating hours and every 50 operating hours thereafter.

**Note:** Change the oil more frequently when operating conditions are extremely dusty or sandy.

Oil Type: Detergent oil (API service SF, SG, SH, SJ, or higher)

Crankcase Capacity: 48 oz. or 1-1/2 qt. (1400 cc or 1.4 l)

Viscosity: See the table below.

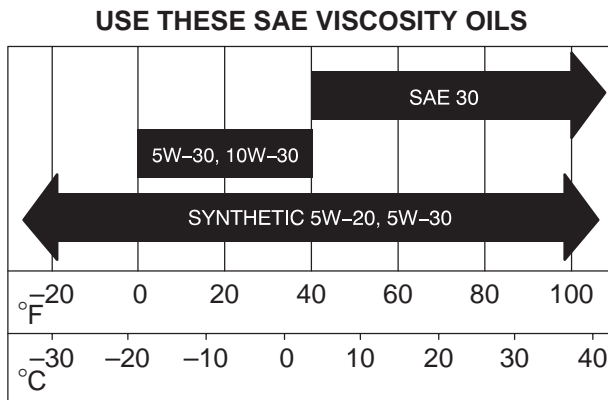

## Checking the Oil Level

1. Park the tractor on a level surface.
2. Disengage the blade (PTO).
3. Shift the ground speed lever into Neutral.
4. Set the parking brake.
5. Stop the engine and wait for all moving parts to stop.
6. Remove the ignition key.
7. Open the hood.
8. Clean around the oil dipstick (Fig. 13) so that dirt cannot fall into the fill hole and damage the engine.

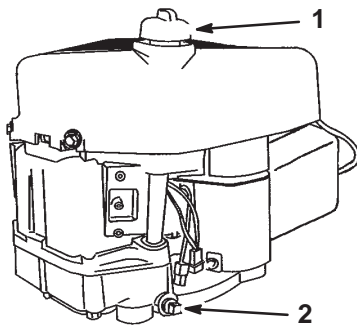

**Figure 13**

1. Oil dipstick/fill hole
2. Oil drain plug

9. Unscrew the oil dipstick and wipe the metal end clean (Fig. 13).

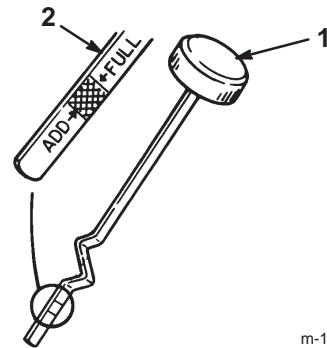

m-1868

**Figure 14**

1. Oil dipstick
2. Metal end

10. Screw the oil dipstick fully onto the fill hole (Fig. 13).

11. Unscrew the dipstick again and look at the metal end. If the oil level is low, slowly pour only enough oil into the fill hole to raise the level to the Full mark on the dipstick.

**Important** Do not overfill the crankcase with oil and run the engine; engine damage may result.

## Changing the Oil

1. Start the engine and let it run for 5 minutes.
  - Note:** This warms the oil so that it drains better.
2. Park the tractor so that the right front side is slightly lower than the left side to ensure that the oil drains completely.
3. Disengage the blade (PTO).
4. Shift the ground speed lever into Neutral.
5. Set the parking brake.
6. Stop the engine and wait for all moving parts to stop.
7. Remove the ignition key.
8. Open the hood.

- Place a drain pan below the oil dipstick/fill hole and remove the drain plug (Fig. 15).

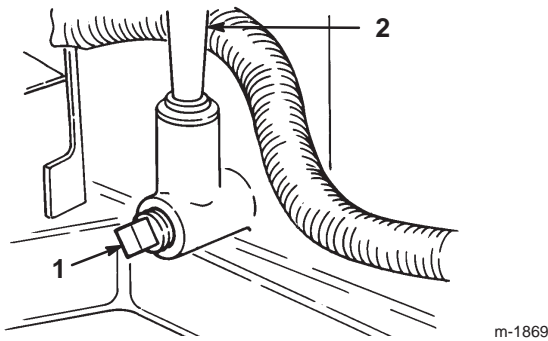

**Figure 15**

- Oil drain plug
- Oil dipstick/fill hole

- When the oil has drained completely, install the oil drain plug.

**Note:** Dispose of the used oil at a certified recycling center.

- Slowly pour about 80% of the specified amount of oil into the fill hole (Fig. 13). Check the oil level; refer to steps 4 and 5 of Checking the Oil Level on page 21.

## Servicing the Battery

Always keep the battery clean and fully charged. Use a paper towel to clean the battery and battery box. If the battery terminals are corroded, clean them with a solution of 4 parts water and 1 part baking soda. Apply a light coating of grease to the battery terminals to prevent them from corroding.

Battery voltage and amperage: 12 volts, 155 cold-cranking amps

### Removing the Battery



#### Warning



**Battery terminals or metal tools could short against metal tractor components, causing sparks. Sparks can cause the battery gasses to explode, resulting in personal injury.**

- **When removing or installing the battery, do not allow the battery terminals to touch any metal parts of the tractor.**
- **Do not allow metal tools to short between the battery terminals and metal parts of the tractor.**

- Disengage the blade (PTO).
- Shift the ground speed lever into Neutral.
- Set the parking brake.

- Stop the engine and wait for all moving parts to stop.
- Remove the ignition key.
- Tip the seat forward to see the battery.
- Disconnect the negative (black) ground cable from the battery post (Fig. 16).

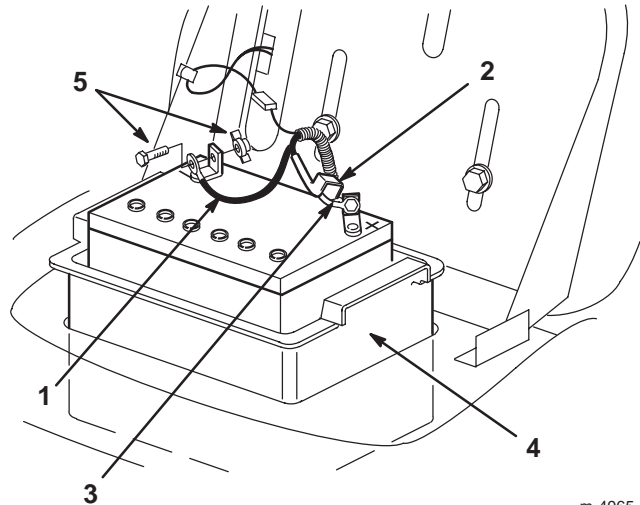

**Figure 16**

- Negative cable (black)
- Rubber cover
- Positive cable (red)
- Battery box
- Bolt and wing nut



#### Warning



**Incorrect battery cable routing could damage the tractor and cables, causing sparks. Sparks can cause the battery gasses to explode, resulting in personal injury.**

- **Always *disconnect* the negative (black) battery cable before disconnecting the positive (red) cable.**
- **Always *connect* the positive (red) battery cable before connecting the negative (black) cable.**

- Slide the rubber cover up the positive (red) cable.
- Disconnect the positive (red) cable from the battery post (Fig. 16).
- Remove the battery box and battery from the chassis (Fig. 16).

## Installing the Battery

1. Put the battery into the battery box and install it into the chassis (Fig. 16).
2. Using the bolt and the wing nut, connect the positive (red) cable to the positive (+) battery post (Fig. 16).
3. Slide the rubber cover over the battery post.
4. Using the bolt and wing nut, connect the negative (black) cable to the negative (-) battery post (Fig. 16).

## Checking the Electrolyte Level

1. Tip the seat forward to see the battery.
2. Look at the side of the battery. The electrolyte must be up to the Upper line (Fig. 17).

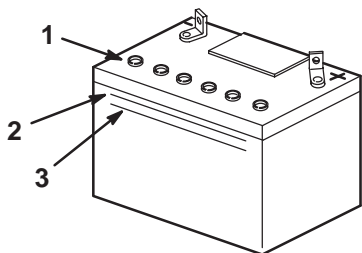

m-5004

Figure 17

1. Vent caps
2. Upper line
3. Lower line

**Note:** Do not allow the electrolyte to fall below the Lower line (Fig. 17).

3. If the electrolyte is low, add distilled water; refer to Adding Water to the Battery on page 23.



### Danger



**Battery electrolyte contains sulfuric acid, a deadly poison that can severely burn you and others.**

- **Do not drink electrolyte and avoid contact with skin, eyes, or clothing. Wear safety glasses to shield your eyes and rubber gloves to protect your hands.**
- **Fill the battery where clean water is always available for flushing the skin.**

## Adding Water to the Battery

The best time to add distilled water to the battery is just before you operate the tractor. This lets the water mix thoroughly with the electrolyte solution.

1. Remove the battery from the tractor; refer to Removing the Battery on page 22.
2. Clean the top of the battery with a paper towel.

**Important** Never fill the battery with distilled water while the battery is installed in the tractor. You could spill electrolyte on other parts and cause corrosion.

3. Remove the vent caps from the battery (Fig. 17).
4. Slowly pour distilled water into each battery cell until the electrolyte level is up to the Upper line (Fig. 17) on the battery case.

**Important** Do not overfill the battery because electrolyte (sulfuric acid) can cause severe corrosion and damage to the chassis.

5. Wait 5 to 10 minutes after filling the battery cells. Add distilled water, if necessary, until the electrolyte level is up to the Upper line (Fig. 17) on the battery case.
6. Install the battery vent caps.

## Charging the Battery



### Warning



**Charging the battery produces gasses that can explode.**

**Never smoke near the battery. Keep sparks and flames away from the battery.**

**Important** Always keep the battery fully charged (1.260 specific gravity), especially when the temperature is below 32°F (0°C) to prevent battery damage.

1. Remove the battery from the chassis; refer to Removing the Battery on page 22.
2. Check the electrolyte level; refer to Checking the Electrolyte Level on page 23.
3. Make sure that the vent caps are installed in the battery and charge it for 1 hour at 25 to 30 amps or 6 hours at 4 to 6 amps. **Do not overcharge the battery.**
4. When the battery is fully charged, unplug the charger from the electrical outlet.

5. Disconnect the charger leads from the battery posts (Fig. 18).

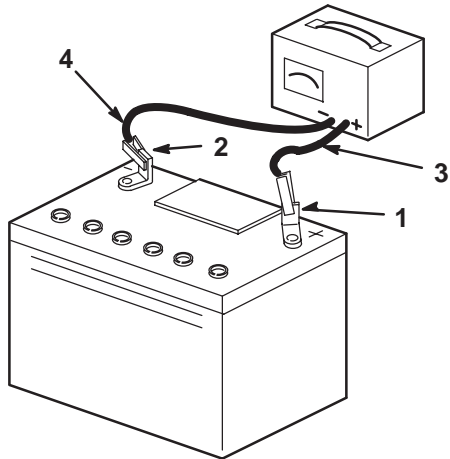

**Figure 18**

m-4970

- |                          |                           |
|--------------------------|---------------------------|
| 1. Positive battery post | 3. Red (+) charger lead   |
| 2. Negative battery post | 4. Black (-) charger lead |

6. Install the battery in the tractor and connect the battery cables; refer to Installing the Battery on page 23.

**Note:** Do not run the tractor with the battery disconnected; electrical damage may occur.

## Servicing the Parking Brake

The brake is on the right side of the rear axle, inside the rear tire (Fig. 19). If the parking brake does not hold securely or has insufficient stopping power, adjust it.

### Checking the Parking Brake

1. Park the tractor on a level surface.
2. Disengage the blade (PTO).
3. Shift the ground speed lever into Neutral.
4. Set the parking brake.
5. Stop the engine and wait for all moving parts to stop.
6. Remove the ignition key.
7. If the rear wheels lock and skid when you push the tractor forward, you do not need to adjust the parking brake. Adjust the parking brake if the wheels turn and do not lock; refer to Adjusting the Parking Brake on page 24.

### Adjusting the Parking Brake

1. Check the parking brake before you adjust it; refer to Checking the Parking Brake on page 24.

2. To increase the braking resistance, tighten the brake adjusting nut (Fig. 19) 1/8 turn clockwise.

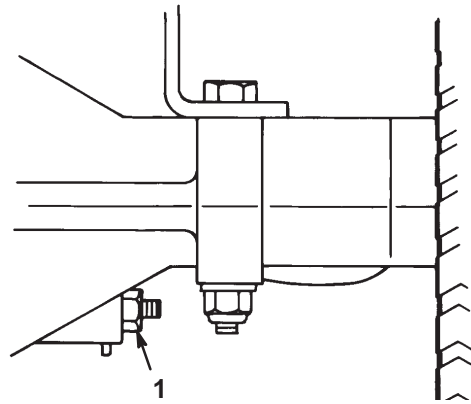

m-1895

**Figure 19**

1. Brake adjusting nut

3. Check the parking brake again.
4. Repeat steps 2 and 3 until the parking brake is set properly.
5. Push down on the clutch/brake pedal to release the parking brake.

**Important** With the parking brake released, the rear wheels must rotate freely when you push the tractor. If the brake drags, loosen the adjusting nut slightly until the wheels rotate freely. If you are unable to properly adjust the parking brake, contact an Authorized Service Dealer immediately.

# Greasing and Lubricating the Tractor

Grease the tractor with a general-purpose grease after every 25 operating hours or once a year, whichever occurs first. Grease the tractor more frequently when the operating conditions are extremely dusty or sandy.

## How to Grease the Tractor

1. Disengage the blade (PTO).
2. Shift the ground speed lever into Neutral.
3. Set the parking brake.
4. Stop the engine and wait for all moving parts to stop.
5. Remove the ignition key.
6. Clean the grease fittings with a rag. Make sure to scrape any paint off the front of the fittings.
7. Connect a grease gun to each fitting and pump grease into it.
8. Wipe up any excess grease.

## Where to Add Grease

Lubricate the front wheels and the steering spindles until the grease begins to ooze out of the bearings (Fig. 20).

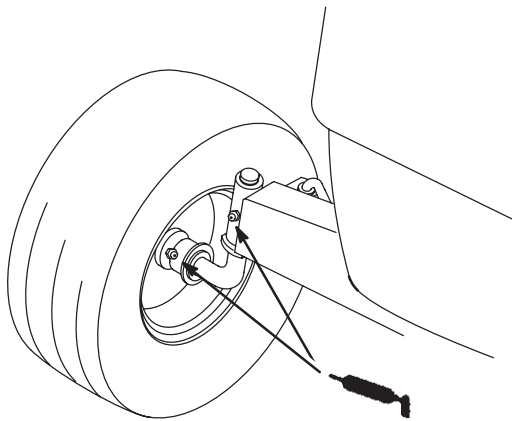

Figure 20

m-2346

## Servicing the Air Cleaner

Foam Element: Clean after every 25 operating hours, or yearly, whichever occurs first.

Paper Element: Replace after every 100 operating hours or yearly, whichever occurs first.

**Note:** Service the air cleaner more frequently (every few hours) if operating conditions are extremely dusty or sandy.

## Removing the Foam and Paper Elements

1. Disengage the PTO, set the parking brake, stop the engine, and remove the ignition key.
2. Open the hood.
3. Clean around the air cleaner to prevent dirt from getting into the engine and causing damage. Pull up on the air cleaner cover handle and rotate it toward the engine (Fig. 21). Remove the air cleaner cover.

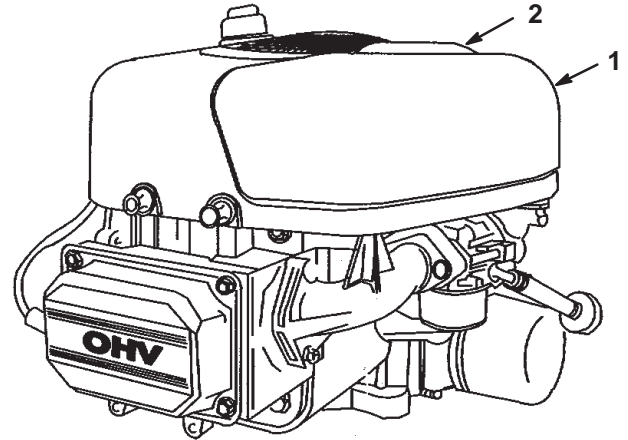

Figure 21

1. Air cleaner cover
2. Air cleaner cover handle

4. Carefully slide the paper element and foam element from the blower housing (Fig. 22).

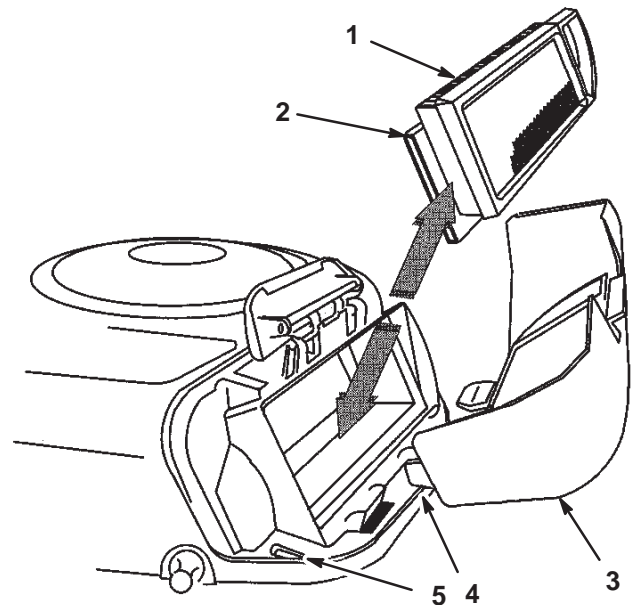

Figure 22

1. Paper element
2. Foam element
3. Air cleaner cover
4. Tab
5. Slot

## Cleaning the Foam and Paper Elements

Foam Element:

1. Wash the foam element in liquid soap and warm water. When the element is clean, rinse it thoroughly.
2. Dry the element by squeezing it in a clean cloth. Do **not** oil the element.

**Important** Replace the foam element if it is torn or worn.

Paper Element:

1. Lightly tap the element on a flat surface to remove dust and dirt.
2. Carefully clean the rubber seal on the paper element to prevent debris from entering the engine.
3. Inspect the element for tears, an oily film, and damage to the rubber seal.

**Important** Never clean the paper element with pressurized air or liquids, such as solvent, gas, or kerosene. Replace the paper element if it is damaged or cannot be cleaned thoroughly.

## Installing the Foam and Paper Elements

**Important** To prevent engine damage, always operate the engine with the complete foam and paper air cleaner assembly installed.

1. Place the foam element and paper element into the blower housing.

**Note:** Make sure that the rubber seal is flat against the air cleaner base.

2. Align the tabs on the air cleaner cover with the slots of the blower housing (Fig. 22). Hook the handle onto the cover and press down on the handle to lock the cover in place.
3. Close the hood.

## Servicing the Spark Plug

Check the spark plug after every 25 operating hours. Install a new **Champion QC12YC or equivalent** spark plug after every 100 operating hours. Make sure that the air gap between the center and side electrodes is 0.030 in. (0.76 mm) before installing the spark plug. Use a spark plug wrench for removing and installing the spark plug and a gapping tool or feeler gauge to check and adjust the air gap.

## Removing the Spark Plug

1. Disengage the blade (PTO).
2. Shift the ground speed into Neutral.
3. Set the parking brake.
4. Stop the engine and wait for all moving parts to stop.
5. Remove the ignition key.
6. Open the hood.
7. Disconnect the wire from the spark plug (Fig. 23).

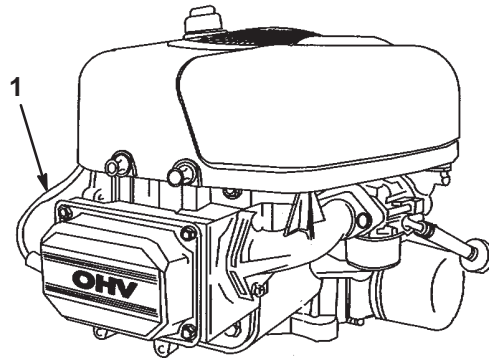

**Figure 23**

1. Spark plug wire
8. Clean around the spark plug to prevent dirt from falling into the engine and potentially causing damage.
9. Remove the spark plug and metal washer.

## Checking the Spark Plug

1. Look at the center of the spark plug (Fig. 24). If you see light brown or gray on the insulator, the engine is operating properly. A black coating on the insulator usually means that the air cleaner is dirty.

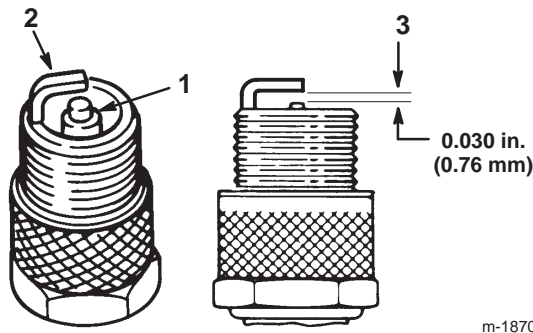

Figure 24

1. Center electrode insulator
2. Side electrode
3. Air gap (not to scale)

**Important** Do not clean the spark plug. Always replace the spark plug when it has a black coating, worn electrodes, an oily film, or cracks.

2. Check the gap between the center and side electrodes (Fig. 24) and bend the side electrode if the gap is not correct.

## Installing the Spark Plug

1. Install the spark plug and metal washer.  
**Note:** Make sure that the air gap is set correctly.
2. Tighten the spark plug to 15 ft-lb (20 N·m).
3. Connect the wire to the spark plug (Fig. 23).
4. Close the hood.

## Checking the Tire Pressure

Maintain the air pressure in the front and rear tires at 20 psi (138 kPa). Check the pressure at the valve stem (Fig. 25) after every 25 operating hours or yearly, whichever occurs first. Check the tires when they are cold to get the most accurate pressure reading.

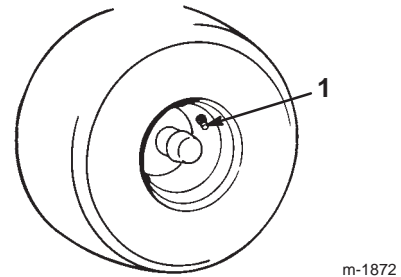

Figure 25

1. Valve stem

## Draining the Fuel Tank



**Danger**



In certain conditions, gasoline is extremely flammable and highly explosive. A fire or explosion from gasoline can burn you and others and can damage property.

- Drain gasoline from the fuel tank when the engine is cold. Do this outdoors in an open area. Wipe up any gasoline that spills.
- Never smoke when draining gasoline, and stay away from an open flame or where a spark may ignite the gasoline fumes.

1. Park the tractor so that the left front side is slightly lower than the right side to ensure that the fuel tank drains completely.
2. Disengage the blade (PTO).
3. Shift the ground speed lever into Neutral.
4. Set the parking brake.
5. Stop the engine and wait for all moving parts to stop.
6. Remove the ignition key.
7. Open the hood.

- Squeeze the ends of the hose clamp together and slide it up the fuel line toward the fuel tank (Fig. 26).

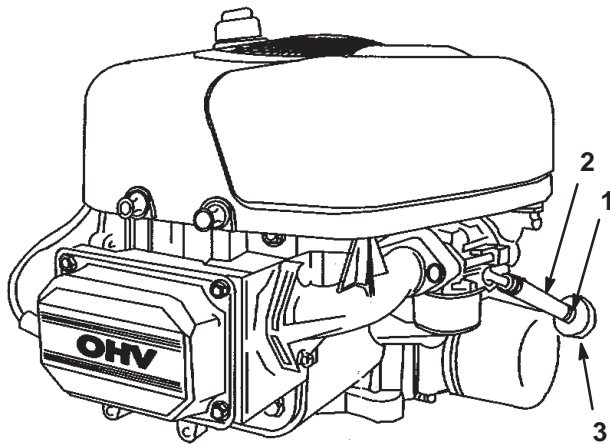

**Figure 26**

- |               |           |
|---------------|-----------|
| 1. Hose clamp | 3. Filter |
| 2. Fuel line  |           |

- Pull the fuel line off the fuel filter (Fig. 26) and allow gasoline to drain into a fuel container or a drain pan.

**Note:** Now is the best time to install a new fuel filter because the fuel tank is empty.

- Install the fuel line onto the fuel filter.

- Slide the hose clamp close to the fuel filter to secure both the fuel line and the fuel filter.

## Replacing the Fuel Filter

Replace the fuel filter after every 100 operating hours or yearly, whichever occurs first. The best time to replace the fuel filter (Fig. 26) is when the fuel tank is empty. Never install a dirty fuel filter after it has been removed from the fuel line.

- Disengage the blade (PTO).
- Shift the ground speed lever into Neutral.
- Set the parking brake.
- Stop the engine and wait for all moving parts to stop.
- Remove the ignition key.
- Open the hood.
- Squeeze the ends of the hose clamps together and slide them away from the old fuel filter (Fig. 26).
- Remove the old fuel filter from the fuel line.
- Install a new fuel filter and move the hose clamps close to it.
- Close the hood.

## Servicing the Fuse

The electrical system is protected by 10 amp, blade-type fuses.

- Pull up on the fuse (Fig. 27) to remove it from the socket.

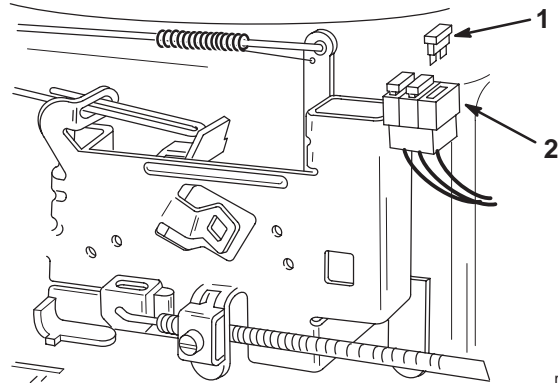

**Figure 27**

- |         |           |
|---------|-----------|
| 1. Fuse | 2. Socket |
|---------|-----------|

- Insert the fuse into socket and push down on the fuse to install it.

## Servicing the Blade

To ensure a superior quality of cut, keep the blade sharp. For convenient sharpening and replacement, keep an extra blade.

**Danger**

**A worn or damaged blade can break and a piece of the blade could be thrown into the operator's or bystander's area, resulting in serious personal injury or death.**

- Inspect the blade periodically for wear or damage.
- Replace a worn or damaged blade.

### Inspecting the Blade

1. Remove the mower; refer to Removing the Mower on page 30.
2. Inspect the cutting edges (Fig. 28). If the edges are not sharp or have nicks, remove the blade and sharpen them; refer to Sharpening the Blade on page 29.

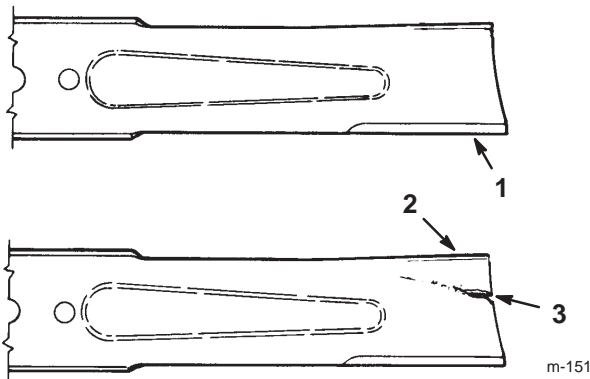

**Figure 28**

1. Cutting edge
2. Curved area
3. Wear/slot forming

3. Inspect the blade, especially the curved area (Fig. 28). If you notice any damage, wear, or a slot forming in this area (Fig. 28), immediately install a new blade.

### Removing the Blade

1. Remove the mower; refer to Removing the Mower on page 30.
2. Carefully tip the mower over.
3. Remove the bolt (5/8 in. wrench), curved washer, retainer, and blade (Fig. 29). Use a block of wood as a wedge between the blade and the mower to lock the blade when you are removing the bolt.

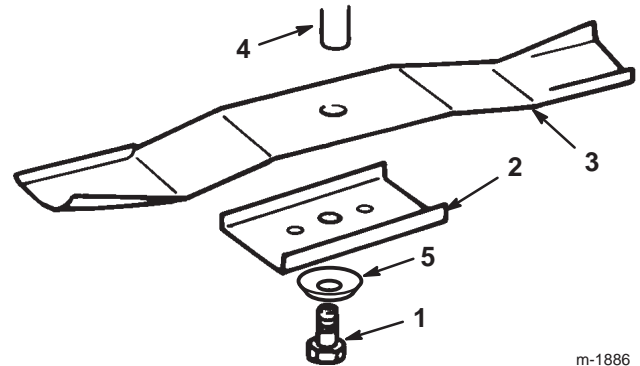

**Figure 29**

1. Bolt
2. Retainer
3. Blade
4. Spindle
5. Curved washer

4. Inspect all parts; replace any parts that are damaged.

### Sharpening the Blade

1. Use a file to sharpen the cutting edge at both ends of the blade (Fig. 30). Maintain the original angle. The blade retains its balance if you remove the same amount of material from both cutting edges.

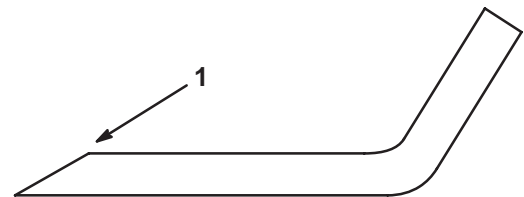

**Figure 30**

1. Sharpen at original angle

2. Check the balance of the blade by putting it on a blade balancer (Fig. 31). If the blade stays in a horizontal position, the blade is balanced and can be used. If the blade is not balanced, file some metal off of the back side of the blade. Repeat this step until the blade is balanced.



**Figure 31**

1. Blade
2. Balancer

## Installing the Blade

1. Install the blade, the blade retainer, the curved washer (cupped side toward blade), and the blade bolt (Fig. 29).

**Important** The curved part of the blade must be pointing upward toward the inside of the mower to ensure proper cutting.

2. Tighten the blade bolt to 45 to 60 ft-lb (61 to 81 N·m).

## Removing the Mower

1. Park the tractor on a level surface.
2. Disengage the blade (PTO).
3. Shift the ground speed lever into Neutral.
4. Set the parking brake.
5. Stop the engine and wait for all moving parts to stop.
6. Remove the ignition key.
7. Disconnect the wire from the spark plug.
8. Move the height-of-cut lever into the “D” notch.

9. Remove the height-of-cut lift assist spring from the retaining bolt (Fig. 32), using the spring tool provided with the tractor.

**Note:** The spring is between the frame and the right rear wheel.

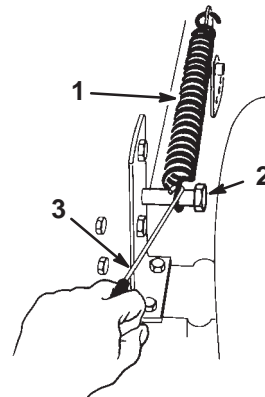

**Figure 32**

1. Spring
2. Bolt
3. Spring tool

**Caution**

When you remove the mower, the spring-tensioned height-of-cut lever could suddenly release and injure you or someone else.

Move the height-of-cut lever to the “D” position and remove the height-of-cut assist spring to release the spring tension.

10. Move the height-of-cut lever into the “A” notch.
11. Remove the hairpin cotter and washer from the blade control arm on the left side of the mower (Fig. 33).

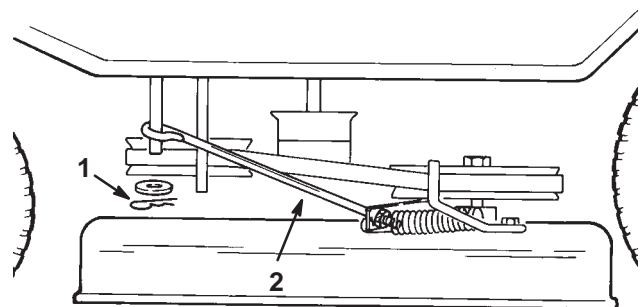
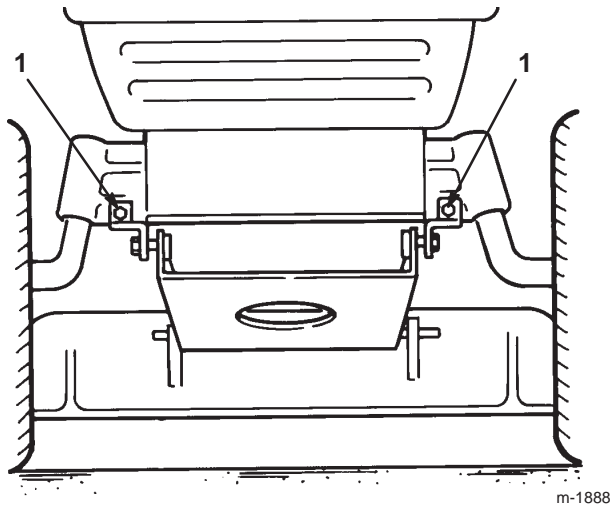

**Figure 33**

1. Hairpin cotter and washer
2. Rod

12. Slide the rod off of the arm.

13. Remove the bolts and locknuts.
14. Pull the 2 mower pivot mount brackets down from the front axle (Fig. 34).



**Figure 34**

1. Pivot mount brackets

15. Remove the hairpin cotter and washer at the top of the mower leveling bracket (Fig. 35).
16. Slide the bracket off the mounting pin. Repeat this step on the opposite side of the mower.

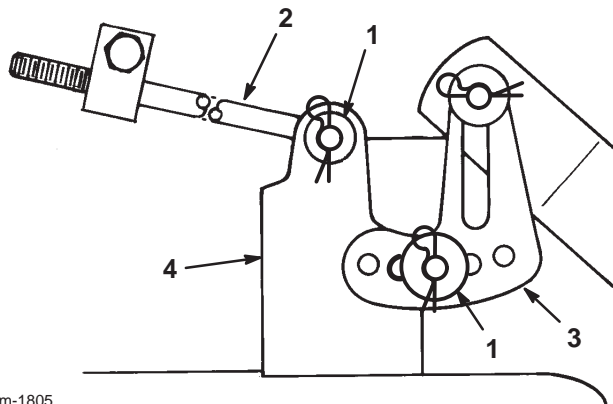

**Figure 35**

1. Hairpin cotter and washer
2. Long rod
3. Leveling bracket
4. Mower mount

17. Remove the hairpin cotter and washer from the end of the long rod (Fig. 35). Slide the rod out of the mower mount. Repeat this step on the opposite side of the mower.

**Important** Tape or tie the long rods against the chassis to protect them from damage when you remove the mower.

18. Remove the mower belt from the lower engine pulley (Fig. 36).

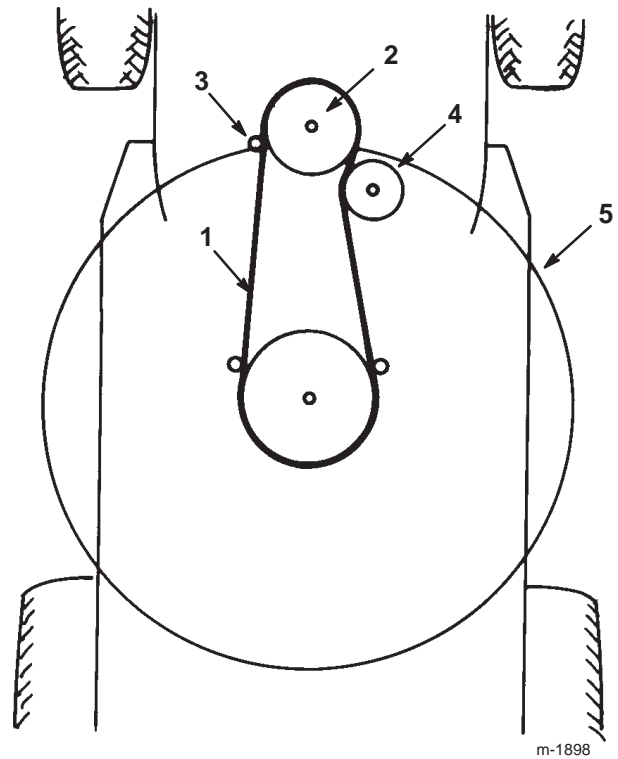

**Figure 36**

Top View

1. Mower belt
2. Engine pulley
3. Belt guide
4. Idler pulley
5. 32" mower

**Note:** You can carefully flex the belt guides just far enough away from the pulley to remove the belt. If it is too difficult to remove the belt, loosen the bolts and nuts that secure the belt guides.

**Important** Do not bend the belt guides away from the pulley because the belt will not operate properly when you install the mower.

19. Turn the front wheels fully to the left.
20. Slide the mower out to the right.

# Installing the Mower

1. Park the tractor on a level surface.
2. Disengage the blade (PTO).
3. Shift the ground speed lever into Neutral.
4. Set the parking brake.
5. Stop the engine and wait for all moving parts to stop.
6. Remove the ignition key.
7. Disconnect the wire from the spark plug.
8. Turn the front wheels fully to the left.
9. Slide the mower under the chassis from the right side.
10. Install the mower belt onto the lower engine pulley (Fig. 36).

**Note:** You can carefully flex the belt guides just far enough away from the pulley to install the belt. If it is too difficult to install the belt, loosen the bolts and nuts that secure the belt guides.

**Important** Do not bend the belt guides away from the pulley. There must be a maximum 1/8 in. (3 mm) between the belt guides and the edge of the pulley to keep the belt on the pulley during operation. If the space is more than 1/8 in. (3 mm), adjust the belt guides and tighten them securely. The belt guides must not contact the pulley.

11. Install the mower pivot mount brackets to the front axle with bolts and locknuts (Fig. 37).

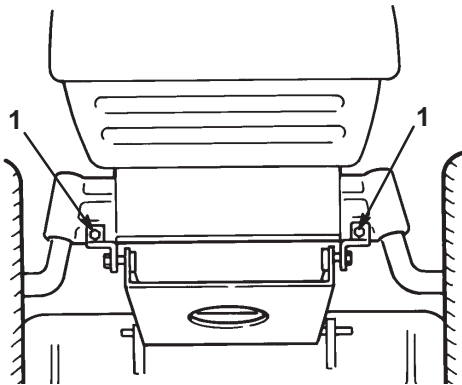
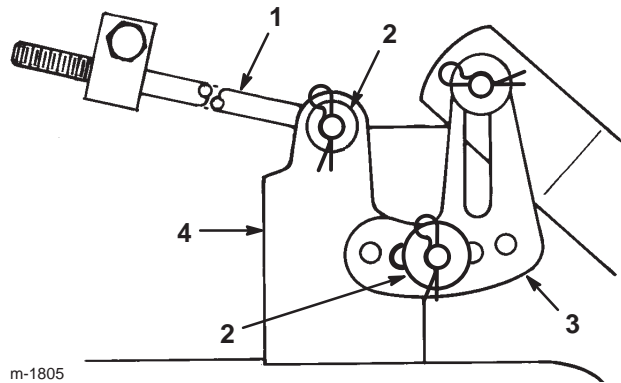

**Figure 37**

1. Pivot mount brackets

12. Move the height-of-cut lever into the “A” notch.

13. Slide the end of the long rod through the hole in the mower mount (Fig. 38).



**Figure 38**

1. Rod
2. Hairpin cotter and washer
3. Leveling bracket
4. Mower mount

14. Install the washer and hairpin cotter to secure the rod in place. Repeat this step on the opposite side of the mower.

15. Mount the slotted mower leveling bracket onto the pin on the height-of-cut arm (Fig. 38).

16. Install the washer and hairpin cotter to secure the mower. Repeat this step on the opposite side of the mower.

17. Install the blade control rod onto the blade control arm and secure it with the washer and hairpin cotter (Fig. 39).

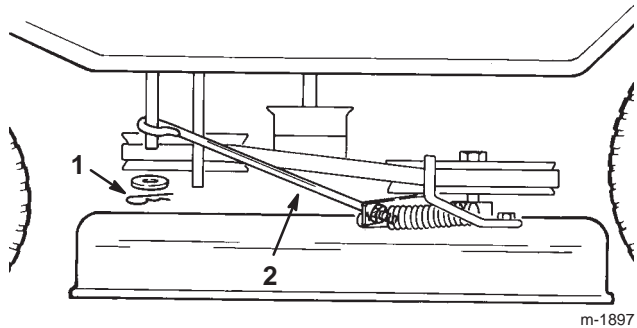
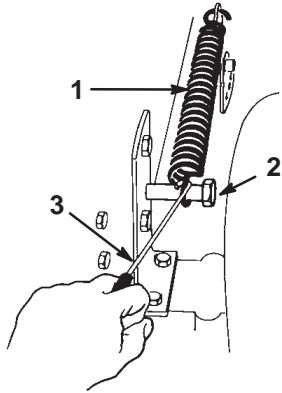

**Figure 39**

1. Hairpin cotter and washer
2. Rod

18. Move the height-of-cut lever into the “D” notch to make it easier to install the height-of-cut lift assist spring.

- Hook the height-of-cut lift assist spring onto the retaining bolt (Fig. 40) using the spring tool provided with the tractor.



m-1851

**Figure 40**

- Spring
- Bolt
- Spring tool

- Check the side-to-side blade level; refer to Leveling the Mower from Side to Side on page 33.

## Replacing the Blade Drive Belt

### Removing the Blade Drive Belt

- Remove the mower; refer to Removing the Mower on page 30.
- Loosen the belt guide mounting bolts and move the belt guides away from the pulley (Fig. 41).

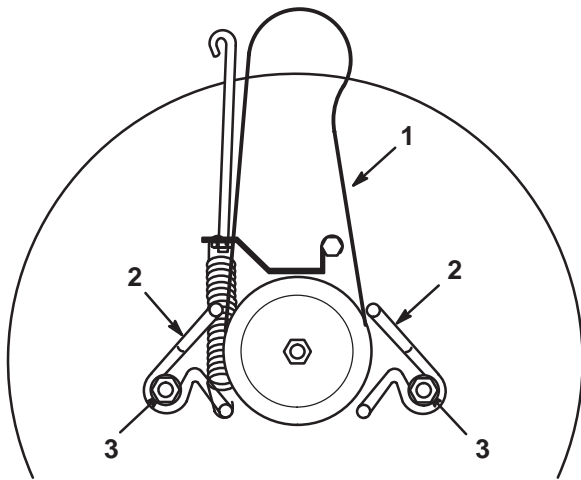

**Figure 41**

Top View

- Mower belt
- Belt guide
- Mounting bolt

- Remove the blade drive belt from the pulley.

## Installing the Blade Drive Belt

- Install the new blade drive belt around the blade pulley and inside both of the belt guides (Fig. 41).
- Adjust the belt guides so they are 1/8 in. (3 mm) away from the pulley. Tighten the mounting bolts (Fig. 41).

**Important** Make sure that the left side belt guide is very tight so that it does not move when the brake spring pulls against it.

- Install the mower; refer to Installing the Mower on page 32.

## Leveling the Mower from Side to Side

The mower blade must be level from side to side. Check the side-to-side level whenever you install the mower or look for an uneven cut on your lawn. Before you level the mower, set the air pressure in the tires to the recommended level; refer to Checking the Tire Pressure on page 27.

- Park the tractor on a level surface.
- Disengage the blade (PTO).
- Shift the ground speed lever into Neutral.
- Set the parking brake.
- Stop the engine and wait for all moving parts to stop.
- Remove the ignition key.
- Disconnect the wire from the spark plug.
- Move the height-of-cut lever into the "C" notch.
- Carefully rotate the blade side to side (Fig. 42).

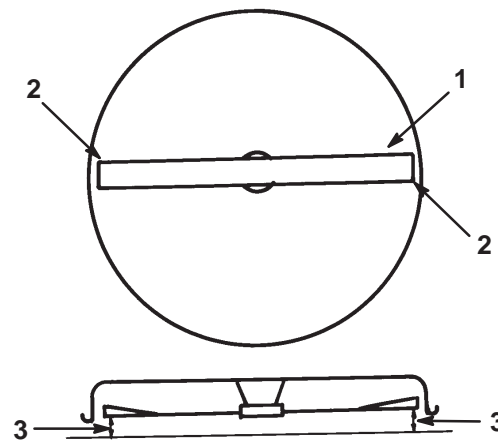

m-1900

**Figure 42**

- Blade side to side
- Outside cutting edges
- Measure here

10. Measure between the outside cutting edges and the flat surface (Fig. 42). If both measurements are not within 3/16 in. (5 mm), adjust it; refer to steps 11 through 14.
11. Remove the hairpin cotter and washer from the leveling bracket (Fig. 43).

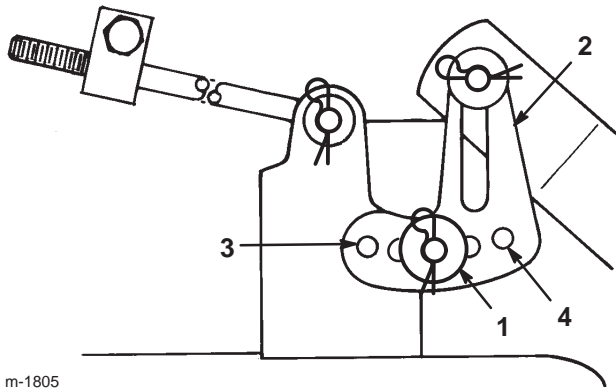

**Figure 43**

- |                              |               |
|------------------------------|---------------|
| 1. Hairpin cotter and washer | 3. Front hole |
| 2. Leveling bracket          | 4. Rear hole  |

12. Position the leveling bracket in a different hole and install the washer and hairpin cotter (Fig. 43).

**Note:** Positioning the leveling bracket toward the front hole lowers the blade height; positioning the leveling bracket toward the rear hole raises the blade height.

13. Repeat steps 11 and 12 on the opposite side of the mower.
14. Check the front-to-rear blade slope; refer to Adjusting the Front-to-Rear Blade Slope on page 34.

## Adjusting the Front-to-Rear Blade Slope

Check the front-to-rear blade slope whenever you install the mower. Before you check the slope, set the air pressure in the tires to the recommended level; refer to Checking the Tire Pressure on page 27. If the front of the mower is more than 5/8 in. (16 mm) lower than the rear of the mower, adjust the blade slope as follows:

1. Park the tractor on a level surface.
2. Disengage the blade (PTO).
3. Shift the ground speed lever into Neutral.
4. Set the parking brake.
5. Stop the engine and wait for all moving parts to stop.
6. Remove the ignition key.
7. Disconnect the wire from the spark plug.

8. Check and adjust the side-to-side blade level if you have not checked the setting; refer to Leveling the Mower from Side-to-Side on page 33.
9. Move the height-of-cut lever into the "C" notch.
10. Check the front-to-rear blade slope by measuring between the bottom of the mower (front center and rear center) and the flat surface (Fig. 44). If the front of the mower is more than 5/8 in. (16 mm) lower than the rear of the mower, adjust it; refer to steps 11 through 17.

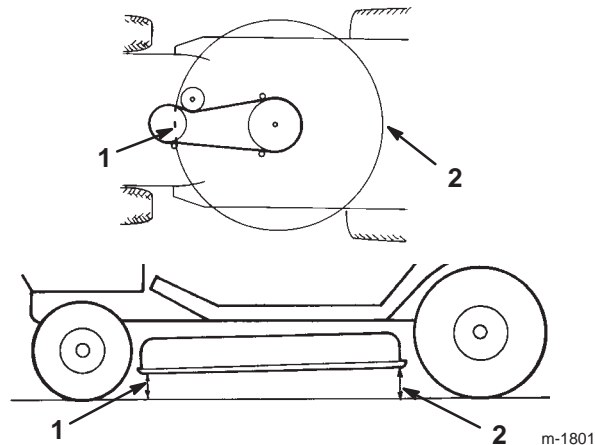

**Figure 44**

- |                         |                        |
|-------------------------|------------------------|
| 1. Measure front center | 2. Measure rear center |
|-------------------------|------------------------|

11. Measure the length of the rod extending out of the front of the adjusting block on the sides of the chassis (Fig. 45). If the rod length is not 3/4 in. (19 mm), remove the hairpin cotter and washer from the end of the rod (Fig. 45) and turn the rod until it extends out 3/4 in. (19 mm).

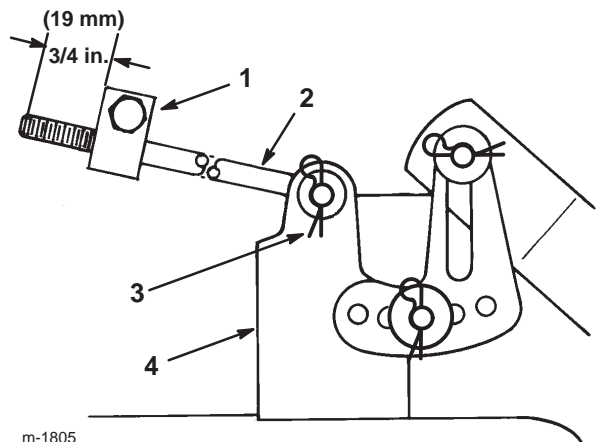

**Figure 45**

- |                    |                              |
|--------------------|------------------------------|
| 1. Adjusting block | 3. Hairpin cotter and washer |
| 2. Long rod        | 4. Mower mount               |

12. Install the end of the rod into the hole in the mower mount and secure it in place with the washer and hairpin cotter.
13. Repeat steps 11 and 12 on the opposite side of the mower.
14. Check the front-to-rear slope again. If the front of the mower is more than 5/8 in. (16 mm) lower than the rear of the mower, proceed to step 15. Otherwise, check the side-to-side level to ensure it did not change.
15. Adjust the front-to-rear slope by rotating the special slope adjusting nuts on both sides of the mower pivot mount (Fig. 46).

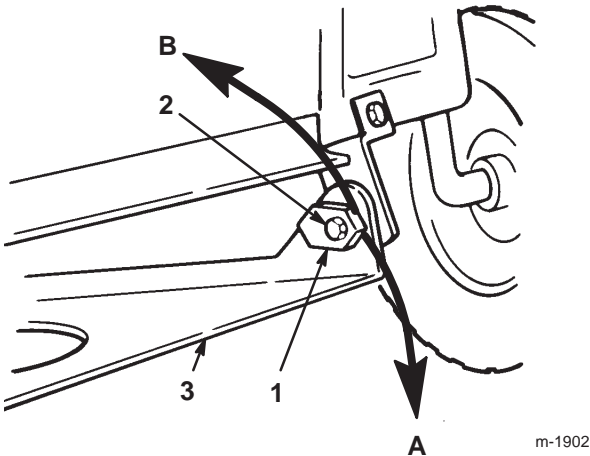

**Figure 46**

- |                               |                      |
|-------------------------------|----------------------|
| 1. Slope adjusting nut (left) | 2. Bolt and locknut  |
| A = Down to raise mower       | 3. Mower pivot mount |
| B = Up to lower mower         |                      |

16. Slowly rotate the left side slope adjusting nut down to raise the front of the mower; rotate the nut up to lower the front of the mower (Fig. 46). Rotate the slope adjusting nut until the front of the mower is 1/4 to 5/8 in. (6 to 16 mm) lower than the rear of the mower.
17. Slowly rotate the right side slope adjusting nut until both adjusting nuts are in the same position.

**Important** If the slope adjustment does not stay in position after you adjust it, tighten the center bolt and locknut and repeat step 16.

18. If you cannot get a 1/4 to 5/8 in. (6 to 16 mm) front slope by rotating the slope adjusting nut, move the mower pivot mount at the mower (Fig. 47).

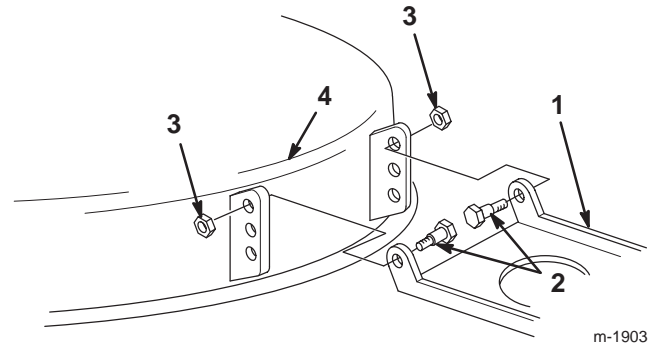

**Figure 47**

- |                   |             |
|-------------------|-------------|
| 1. Mower pivot    | 3. Locknuts |
| 2. Shoulder bolts | 4. Mower    |

19. Remove the shoulder bolts and locknuts from the mower (Fig. 47).
  20. Lower the mower pivot a hole and install the shoulder bolts and locknuts (Fig. 47).
- Note:** If your mower has only 1 hole, see an Authorized Service Dealer.
21. Repeat the front-to-rear blade slope adjustment; refer to steps 15 through 17.
  22. Check the front-to-rear slope again; refer to step 5.
  23. When the front-to-rear blade slope is correct, check the side-to-side level of the mower; refer to Leveling the Mower from Side to Side on page 33.
  24. Connect the wire to the spark plug.

## Washing the Underside of the Mower

After each use, wash the underside of the mower to prevent grass buildup for improved mulching action and clipping dispersal.

1. Park the tractor on a hard level surface.
2. Disengage the blade (PTO).
3. Stop the engine and wait for all moving parts to stop.
4. Remove the ignition key.

- Attach the coupling to the end of the mower washout fitting and turn the water on high (Fig. 48).

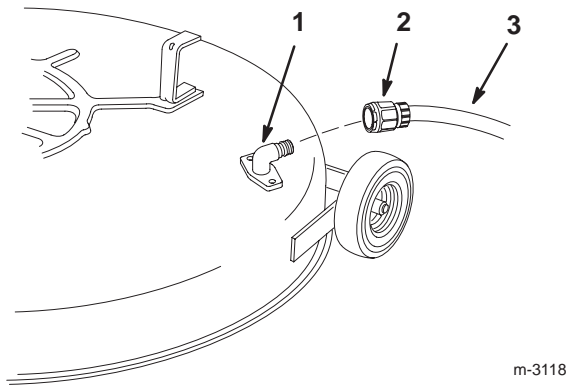

**Figure 48**

- Washout fitting
- Coupling (not supplied)
- Hose

**Note:** Spread petroleum jelly on the washout fitting o-ring to make the coupling slide on easier and to protect the o-ring.

- Lower the mower to the lowest height of cut.
- Sit on the seat and start the engine.
- Engage the blade (PTO) and let the mower run for 1 to 3 minutes.
- Disengage the blade (PTO).
- Stop the engine and wait for all moving parts to stop.
- Remove the ignition key.
- Turn off the water and remove the coupling from the washout fitting.

**Note:** If the mower is not clean after washing it, soak it and let it stand for 30 minutes. Then repeat the process.

- Run the mower again for 1 to 3 minutes to remove the excess water.



## Warning



A broken or missing washout fitting could expose you and others to thrown objects or to blade contact. Contact with the blade or thrown debris may cause injury or death.

- Replace broken or missing washout fitting immediately before using the mower again.
- Plug any holes in the mower with bolts and locknuts.
- Never put your hands or feet under the mower or through openings in the mower.

## Cleaning and Storing the Tractor

- Disengage the blade (PTO).
- Set the parking brake.
- Stop the engine and wait for all moving parts to stop.
- Remove the ignition key.
- Remove the grass clippings, dirt, and grime from the external parts of the entire tractor, especially the engine. Clean the dirt and chaff from the outside of the engine cylinder head fins and blower housing.

**Important** Wash the tractor with a mild detergent and water. **Do not use a pressure washer to wash the tractor.** Pressure washing may damage the electrical system or wash away necessary grease at the friction points. Avoid using water excessively, especially near the control panel, lights, engine, and battery.

- Check the parking brake; refer to Checking the Parking Brake on page 24.
- Service the air cleaner; refer to Servicing the Air Cleaner on page 25.
- Grease the chassis; refer to Greasing and Lubricating the Tractor on page 25.
- Change the engine oil; refer to Servicing the Engine Oil on page 21.
- Check the tire pressure; refer to Checking the Tire Pressure on page 27.
- When storing the tractor over 30 days, prepare it as follows:
  - Add a petroleum-based stabilizer/conditioner to the fuel in the tank according to the instructions from the stabilizer manufacturer. **Do not use an alcohol-based stabilizer (ethanol or methanol).**

**Note:** A fuel stabilizer/conditioner is most effective when mixed with fresh gasoline and used at all times.

- Run the engine for 5 minutes to distribute the conditioned fuel through the fuel system.
- Stop the engine, allow it to cool, and drain the fuel tank; refer to Draining the Fuel Tank on page 27.
- Start the engine and run it until it stops.
- Choke or prime the engine.
- Start and run the engine until it will not start again.
- Recycle the old fuel according to local codes.

**Important** Do not store stabilizer/conditioned gasoline over 90 days.

12. Remove and inspect the spark plug; refer to Servicing the Spark Plug on page 26. With the spark plug removed from the engine, pour 2 tablespoons of engine oil into the spark plug hole. Use the electric starter to crank the engine and distribute the oil inside the cylinder. Install the spark plug, but do not connect the wire to the spark plug.
13. Disconnect the negative battery cable. Clean the battery and battery terminals. Check the electrolyte level and charge it fully; refer to Servicing the Battery on page 22. Leave the negative battery cable disconnected from the battery during storage.

**Important** The battery must be fully charged to prevent it from freezing and being damaged at temperatures below 32°F (0°C). You can store a fully charged battery during the winter without recharging.

14. Check and tighten all bolts, nuts, and screws. Repair or replace any part that is worn or damaged.
15. Paint all scratched or bare metal surfaces with paint available from an Authorized Service Dealer.
16. Store the tractor in a clean, dry garage or storage area. Remove the ignition and KeyChoice keys from the mower and keep them in a memorable place. Cover the tractor to protect it and keep it clean.

# Wiring Diagram

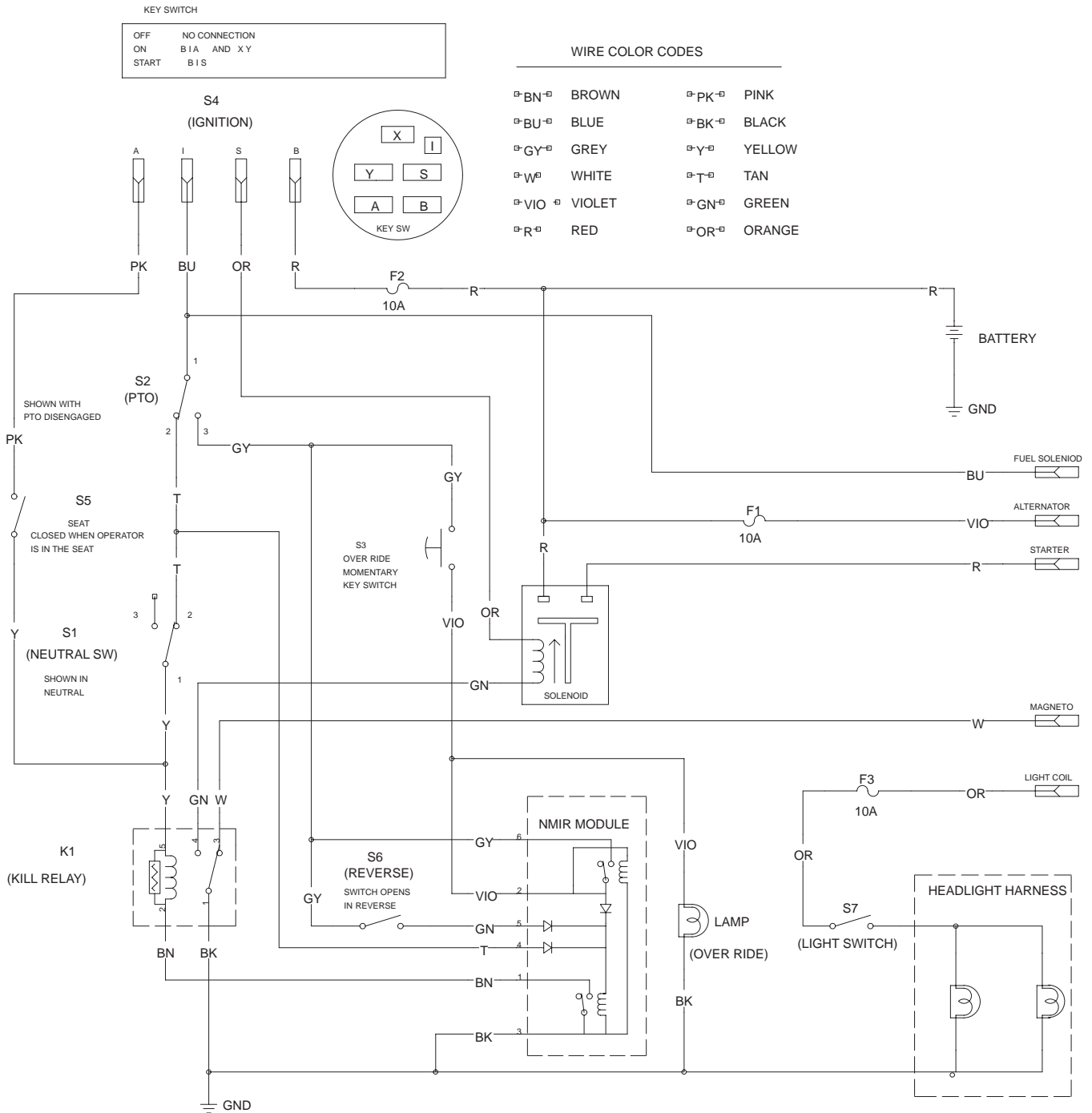

# Troubleshooting

Problem	Possible Causes	Corrective Action
The starter does not crank.	<ol style="list-style-type: none"> <li>1. The blade (PTO) is engaged.</li> <li>2. The parking brake is not on.</li> <li>3. The battery is dead.</li> <li>4. The electrical connections are corroded or loose.</li> <li>5. A fuse is blown.</li> <li>6. A relay or switch is damaged.</li> </ol>	<ol style="list-style-type: none"> <li>1. Disengage the blade control (PTO).</li> <li>2. Set the parking brake.</li> <li>3. Charge the battery.</li> <li>4. Check the electrical connections for good contact.</li> <li>5. Replace the fuse.</li> <li>6. Contact an Authorized Service Dealer.</li> </ol>
The engine will not start, starts hard, or fails to keep running.	<ol style="list-style-type: none"> <li>1. The operator is not seated.</li> <li>2. The fuel tank is empty.</li> <li>3. The air cleaner is dirty.</li> <li>4. The spark plug wire is loose or disconnected.</li> <li>5. The spark plug is pitted, fouled, or the gap is incorrect.</li> <li>6. The choke is not closing.</li> <li>7. There is dirt in the fuel filter.</li> <li>8. The idle speed is too low or the mixture is incorrect.</li> <li>9. Dirt, water, or stale fuel is in the fuel system.</li> </ol>	<ol style="list-style-type: none"> <li>1. Sit on the seat.</li> <li>2. Fill the fuel tank with gasoline.</li> <li>3. Clean or replace the air cleaner element.</li> <li>4. Connect the wire to the spark plug.</li> <li>5. Install a new, correctly-gapped spark plug.</li> <li>6. Adjust the throttle cable.</li> <li>7. Replace the fuel filter.</li> <li>8. Adjust the carburetor idle speed and idle mixture.</li> <li>9. Contact an Authorized Service Dealer.</li> </ol>
The engine loses power.	<ol style="list-style-type: none"> <li>1. The engine load is excessive.</li> <li>2. The air cleaner is dirty.</li> <li>3. The oil level in the crankcase is low.</li> <li>4. The cooling fins and air passages under the engine blower housing are plugged.</li> <li>5. The spark plug is pitted, fouled, or the gap is incorrect.</li> <li>6. The vent hole in the fuel cap is plugged.</li> <li>7. There is dirt in the fuel filter.</li> <li>8. Dirt, water, or stale fuel is in the fuel system.</li> </ol>	<ol style="list-style-type: none"> <li>1. Shift into a lower gear to reduce the ground speed.</li> <li>2. Clean the air cleaner element.</li> <li>3. Add oil to the crankcase.</li> <li>4. Remove the obstruction from the cooling fins and air passages.</li> <li>5. Install a new, correctly-gapped spark plug.</li> <li>6. Clean or replace the fuel cap.</li> <li>7. Replace the fuel filter.</li> <li>8. Contact an Authorized Service Dealer.</li> </ol>

<b>Problem</b>	<b>Possible Causes</b>	<b>Corrective Action</b>
The engine overheats.	<ol style="list-style-type: none"> <li>1. The engine load is excessive.</li> <li>2. The oil level in the crankcase is low.</li> <li>3. The cooling fins and air passages under the engine blower housing are plugged.</li> </ol>	<ol style="list-style-type: none"> <li>1. Shift into a lower gear to reduce the ground speed.</li> <li>2. Add oil to the crankcase.</li> <li>3. Remove the obstruction from the cooling fins and air passages.</li> </ol>
There is an abnormal vibration.	<ol style="list-style-type: none"> <li>1. The blade is bent or unbalanced.</li> <li>2. The blade mounting bolt is loose.</li> <li>3. The engine mounting bolts are loose.</li> <li>4. There is a loose engine pulley, idler pulley, or blade pulley.</li> <li>5. The engine pulley is damaged.</li> </ol>	<ol style="list-style-type: none"> <li>1. Install a new blade.</li> <li>2. Tighten the blade mounting bolt.</li> <li>3. Tighten the engine mounting bolts.</li> <li>4. Tighten the appropriate pulley.</li> <li>5. Contact an Authorized Service Dealer.</li> </ol>
The blade does not rotate.	<ol style="list-style-type: none"> <li>1. The blade drive belt is worn, loose, or broken.</li> <li>2. The blade drive belt is off of the pulley.</li> </ol>	<ol style="list-style-type: none"> <li>1. Install a new blade drive belt.</li> <li>2. Install the blade drive belt and check the idler pulley and belt guides for the correct position.</li> </ol>
The tractor does not drive.	<ol style="list-style-type: none"> <li>1. The traction belt is worn, loose, or broken.</li> <li>2. The traction belt is off the pulley.</li> <li>3. The transmission does not shift.</li> </ol>	<ol style="list-style-type: none"> <li>1. Contact an Authorized Service Dealer.</li> <li>2. Contact an Authorized Service Dealer.</li> <li>3. Contact an Authorized Service Dealer.</li> </ol>
The cutting height is uneven.	<ol style="list-style-type: none"> <li>1. The tire pressure is incorrect.</li> <li>2. The mower is not level.</li> <li>3. The underside of the mower is dirty.</li> </ol>	<ol style="list-style-type: none"> <li>1. Set the tire pressure.</li> <li>2. Level the mower from side to side and from front to rear.</li> <li>3. Clean the underside of the mower.</li> </ol>