



Workman[®] e2050 Utility Vehicle

Model No. 07280TC—Serial No. 230000001 and Up

Operator's Manual

Contents

	Page
Introduction	2
Safety	3
Safe Operating Practices	3
Before Operating	3
While Operating	4
Handling and Servicing Batteries	6
General Maintenance	7
Sound Pressure Level	7
Vibration Level	7
Slope Chart	9
Safety and Instruction Decals	11
Specifications	13
Optional Equipment	13
Setup	14
Loose Parts	14
Installing the Rear Wheels	15
Installing the Front Wheels	15
Installing the Steering Wheel	15
Installing the Bumper	15
Installing the Seats	16
Installing the Hitch	16
Installing the Batteries	16
Installing the Cargo Box	17
Checking the Tire Pressure	18
Setting the Charger Voltage	18
Operation	18
Think Safety First	18
Controls	18
Pre-Operating Checks	20
Operating the Vehicle	20
Stopping the Vehicle	20
Parking the Vehicle	20
Understanding and Using the Battery System	21
Operating the Cargo Box	22
Breaking-in a New Vehicle	23
Loading the Cargo Box	23
Transporting the Vehicle	24
Towing the Vehicle	24
Towing a Trailer	24
Maintenance	25
Recommended Maintenance Schedule	25
Heavy Duty Operation	27
Jacking the Vehicle	27
Maintaining the Batteries	28
Greasing the Vehicle	30

	Page
Servicing the Brakes	31
Inspecting the Tires	32
Adjusting the Front Suspension	32
Adjusting the Front Wheel Toe-In	33
Checking the Transaxle Oil Level	34
Replacing the Fuses	34
Replacing the Headlights	34
Washing the Vehicle	35
Electrical Schematic	36
Troubleshooting	37

Introduction

Read this manual carefully to learn how to operate and maintain your product properly. The information in this manual can help you and others avoid injury and product damage. Although Toro designs and produces safe products, you are responsible for operating the product properly and safely.

You may contact Toro directly at www.Toro.com for product and accessory information, help finding a dealer, or to register your product.

Whenever you need service, genuine Toro parts, or additional information, contact an Authorized Service Dealer or Toro Customer Service and have the model and serial numbers of your product ready. Figure 1 illustrates the location of the model and serial numbers on the product.

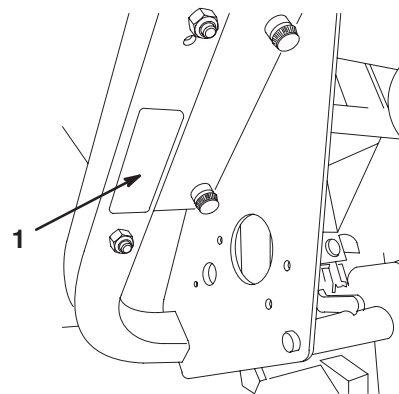

Figure 1

1. Location of the model and serial numbers

Write the product model and serial numbers in the space below:

Model No. _____
Serial No. _____

This manual identifies potential hazards and has special safety messages that help you and others avoid personal injury and even death. **Danger**, **Warning**, and **Caution** are signal words used to identify the level of hazard. However, regardless of the hazard, be extremely careful.

Danger signals an extreme hazard that *will* cause serious injury or death if you do not follow the recommended precautions.

Warning signals a hazard that *may* cause serious injury or death if you do not follow the recommended precautions.

Caution signals a hazard that may cause minor or moderate injury if you do not follow the recommended precautions.

This manual uses two other words to highlight information.

Important calls attention to special mechanical information and **Note**: emphasizes general information worthy of special attention.

Safety

Improper use or maintenance by the operator or owner can result in injury. To reduce the potential for injury, comply with these safety instructions and always pay attention to the safety alert  symbol, which means CAUTION, WARNING, or DANGER—“personal safety instruction.” Failure to comply with the instruction may result in personal injury or death.

Supervisors, operators, and service persons should be familiar with the following standards and publications: (The material may be obtained from the address shown).

- Flammable and Combustible Liquids Code:
ANSI/NFPA 30
- National Fire Protection Association:
ANSI/NFPA #505; Powered Industrial Trucks
National Fire Prevention Association
Barrymarch Park
Quincy, Massachusetts 02269 U.S.A.
- ANSI/ASME B56.8 Personal Burden Carriers
American National Standards Institute, Inc.
1430 Broadway
New York, New York 10018 U.S.A.
- SAE J2258 Light Utility Vehicle
SAE International
400 Commonwealth Drive
Warrendale, PA 15096-0001 U.S.A.
- ANSI/UL 583; Electric Battery-Powered Industrial Trucks
American National Standards Institute, Inc.
1430 Broadway
New York, New York 10018 U.S.A.
or
Underwriters Laboratories
333 Pfingsten Road
Northbrook, Illinois 60062 U.S.A.

Safe Operating Practices



Warning



The Workman is an off-highway vehicle only and is not designed, equipped, or manufactured for use on public streets, roads, or highways.

Supervisor's Responsibilities

- Make sure that operators are thoroughly trained and familiar with the Operator's Manual and all labels on the vehicle.
- Establish your own special procedures and work rules for unusual operating conditions (e.g. slopes too steep for vehicle operation).

Note: This vehicle has a supervisor speed limit switch to allow you to limit the maximum speed that the operator can drive the vehicle. Refer to Supervisor Speed Limit Switch, page 20.

Before Operating

- Operate the vehicle only after reading and understanding the contents of this manual.
- **Never** allow children to operate the vehicle. Anyone who operates the vehicle should have a motor vehicle license.
- **Never** allow other adults to operate the vehicle without first reading and understanding the Operator's Manual. Only trained and authorized persons should operate this vehicle. Make sure that all operators are physically and mentally capable of operating the vehicle.
- This vehicle is designed to carry **only you**, the operator, and **one passenger** in the seat provided by the manufacturer. **Never** carry any other passengers on the vehicle.
- **Never** operate the vehicle when under the influence of drugs or alcohol. Even prescription drugs and cold medicines can cause drowsiness.
- Do not drive the vehicle when you are tired. Be sure to take occasional breaks. It is very important that you stay alert at all times.
- Become familiar with the controls and know how to stop the vehicle quickly.
- Keep all shields, safety devices, and decals in place. If a shield, safety device, or decal is malfunctioning, illegible, or damaged, repair or replace it before operating the vehicle.

- Always wear substantial shoes. Do not operate the vehicle while wearing sandals, tennis shoes, or sneakers. Do not wear loose fitting clothing or jewelry which could get caught in moving parts and cause personal injury.
- Wearing safety glasses, safety shoes, long pants, and a helmet is advisable and required by some local safety and insurance regulations.
- Avoid driving when it is dark, especially in unfamiliar areas. If you must drive when it is dark, be sure to drive cautiously and use the headlights.
- Be extremely careful when operating around people. Be aware of bystanders.
- Before operating the vehicle, always check the designated areas of the vehicle that are stated in the Pre-operating section of this manual. If something is wrong, do **not** use the vehicle. Make sure that the problem is corrected before operating the vehicle or attachment.

While Operating

- The operator and passenger should remain seated whenever the vehicle is in motion. The operator should keep both hands on the steering wheel whenever possible, and the passenger should use the hand holds provided. Keep your arms and legs within the vehicle body at all times.
- Drive slower and turn less sharply when you are carrying a passenger. Remember your passenger may not be expecting you to brake or turn and may not be ready.
- Always watch out for and avoid low overhangs such as tree limbs, door jambs, and over-head walkways. Make sure there is enough room over head to easily clear the vehicle and your head.
- Failure to operate the vehicle safely may result in an accident, tip over of the vehicle, and serious injury or death. Drive carefully.
 - Use extreme caution, reduce speed, and maintain a safe distance around sand traps, ditches, creeks, ramps, unfamiliar areas, or any areas that have abrupt changes in ground conditions or elevation.
 - Watch for holes or other hidden hazards.
 - Use extra caution when operating the vehicle on wet surfaces, in adverse weather conditions, at higher speeds, or with a full load. Stopping time and distance will increase with a full load.
 - Avoid sudden stops and starts. Do not go from reverse to forward or forward to reverse without first coming to a complete stop.
- Slow down before turning. Do not attempt sharp turns or abrupt maneuvers or other unsafe driving actions that may cause a loss of vehicle control.
- When dumping, do not let anyone stand behind the vehicle and do not dump the load on anyone's feet. Release the tailgate latches from the side of the box, not from behind.
- Only operate the vehicle when the cargo box is down and latched.
- Before backing up, look to the rear and ensure that no one is behind you. Back up slowly.
- Watch out for traffic when you are near or crossing roads. Always yield the right of way to pedestrians and other vehicles. This vehicle is **not** designed for use on streets or highways. Always signal your turns or stop early enough so that other people know what you plan to do. Obey all traffic rules and regulations.
- The electrical system of the vehicle can produce sparks capable of igniting explosive materials. Never operate the vehicle in or near an area where there is dust or fumes in the air which are explosive.
- If you are ever unsure about safe operation, **stop work** and ask your supervisor.
- If the vehicle ever vibrates abnormally, stop immediately, wait for all motion to stop, and inspect the vehicle for damage. Repair all damage before commencing operation.
- Before getting off of the seat:
 - A. Stop the movement of the vehicle.
 - B. Set the parking brake.
 - C. Turn the key to Off.
 - D. Remove the key.

Note: If the vehicle is on an incline, block the wheels after getting off of the vehicle.

Braking

- Slow down before you approach an obstacle. This gives you extra time to stop or turn away. Hitting an obstacle can damage the vehicle and its contents. More important, it can injure you and your passenger.
- Gross Vehicle Weight (GVW) has a major impact on your ability to stop and/or turn. Heavy loads and attachments make a vehicle harder to stop or turn. The heavier the load, the longer it takes to stop.

- Decrease the vehicle speed if the cargo box has been removed and there is no attachment on the vehicle. The braking characteristics change and fast stops may cause the rear wheels to lock up, which may affect the control of the vehicle.
- Turf and pavement are slippery when they are wet. It can take 2 to 4 times as long to stop on wet surfaces as on dry surfaces. If you drive through standing water deep enough to get the brakes wet, they will not work well until they are dry. After driving through water, you should test the brakes to make sure they work properly. If they do not, drive slowly while putting light pressure on the brake pedal. This will dry the brakes out.

Operating on Hills

Warning

Operating the vehicle on a hill may cause tipping or rolling of the vehicle, or the engine may stall and you could lose headway on the hill. This could result in personal injury.

- **Do not accelerate quickly or slam on the brakes when backing down a hill, especially with a load.**
- **If the battery runs out or you lose headway on a hill, slowly back straight down the hill. Never attempt to turn the vehicle around.**
- **Never drive across a steep hill; always drive straight up or down or go around the hill.**
- **Avoid turning on a hill.**
- **Reduce your load and the speed of the vehicle.**
- **Avoid stopping on hills, especially with a load.**

These extra cautions need to be taken when operating the vehicle on a hill:

- Slow down before starting up or down a hill.
- If the batteries run low or you begin to lose headway while climbing a hill, gradually apply the brakes and slowly back straight down the hill.
- We strongly recommend installing the optional ROPS Kit when operating on hilly terrain.
- Turning while traveling up or down hills can be dangerous. If you have to turn while on a hill, do it slowly and cautiously. Never make sharp or fast turns.
- Heavy loads affect stability. Reduce the weight of the load and your speed when operating on hills or if the load has a high center of gravity. Secure the load to prevent it from shifting.
- Avoid stopping on hills, especially with a load. Stopping while going down a hill will take longer than stopping on level ground. If the vehicle must be stopped, avoid sudden speed changes, which may

initiate tipping or rolling of the vehicle. Do not slam on the brakes when rolling backward, as this may cause the vehicle to overturn.

- Travel straight up and down slopes whenever possible.

Operating on Rough Terrain

Reduce speed and load when operating on rough terrain, uneven ground, and near curbs, holes, and other sudden changes in terrain. Loads may shift, causing the vehicle to become unstable.

We strongly recommend installing the optional ROPS Kit when operating on rough terrain.

Warning

Sudden changes in terrain may cause abrupt steering wheel movement, possibly resulting in hand and arm injuries.



- **Reduce your speed when operating on rough terrain and near curbs.**
- **Grip the steering wheel loosely around the perimeter. Keep your hands clear of the steering wheel spokes.**

Loading and Dumping

The weight and position of the cargo and passenger can change the vehicle center of gravity and vehicle handling. To avoid loss of control and personal injury, follow these guidelines:

- Do **not** carry loads which **exceed** the load limits described on the vehicle weight label; refer to Specifications, page 13, for vehicle weight limits. The load rating is for **level surfaces only**.
- Reduce the weight of the load when operating on hills and rough terrain to avoid tipping or overturning of the vehicle.
- Reduce the weight of the load if the center of gravity is high. Items such as bricks, fertilizer, or landscape timbers stack higher in the box. The higher a load is stacked, the more likely the vehicle is to tip over. Distribute the load as low as possible, making sure that the load does not affect rear visibility.
- Position the weight of the load evenly from side to side. If you position the load toward one of the sides, the vehicle is more likely to tip over while turning.
- Position the weight of a load evenly from front to back. If you position the load behind the rear axle, it will reduce the weight on the front wheels. This may result in a loss of steering control or cause the vehicle to tip over on hills or bumpy terrain.

- Use extra caution if the load exceeds the dimensions of the box and when handling off-center loads that cannot be centered. Keep loads balanced and secure to prevent them from shifting.
- Always secure loads so that they do not shift. If a load is not secured, or you are transporting a liquid in a large container such as a sprayer, the load can shift. This shifting happens most often while turning, going up or down hills, suddenly changing speeds, or while driving over rough surfaces. Shifting loads can cause the vehicle to tip over.

Warning

The weight of the box may be heavy. Hands or other body parts could be crushed.

- **Keep hands and other body parts clear when lowering the box.**
- **Do not dump materials on bystanders.**

- Never dump a loaded cargo box while the vehicle is sideways on a hill. The change in weight distribution may cause the vehicle to overturn.
- When operating with a heavy load in the cargo box, reduce your speed and allow for sufficient braking distance. Do not suddenly apply the brakes. Use extra caution on slopes.
- Be aware that heavy loads increase your stopping distance and reduce your ability to turn quickly without tipping over.
- The rear cargo space is intended for load carrying purposes only, not for passengers.

Handling and Servicing Batteries

- To reduce the potential for fire, keep the batteries and motor area free of excessive grease, grass, leaves, and accumulation of dirt.
- Always *disconnect and remove* a battery cable before servicing any electrical components.
- Disconnecting any battery cable will inhibit operation of the electrical system.
- Battery electrolyte contains sulfuric acid. Sulfuric acid produces hydrogen gas which, in the right proportions is explosive.
 - Always service, store, and charge the vehicle in a well ventilated area.
 - Keep sparks and open flames away from the batteries.
 - Do not smoke near the batteries.

- Never use an open flame to check the level or leakage of battery electrolyte.
- Use caution when handling and working around electrolyte. The sulfuric acid in electrolyte can burn skin and damage clothing. Furthermore, it can be emitted as a gas that can damage your lungs.
 - Wear proper eye, hand, and face protection.
 - Do not lean over the batteries at any time.
 - Avoid breathing battery fumes.
 - Fill the batteries where clean water is always available for flushing the skin.
 - If you get electrolyte on your skin or eyes, flush the affected area for 20 minutes with clean water. Remove acid soaked clothing . Seek medical attention immediately.
 - Keep children and pets away from the batteries and electrolyte.
- Electrolyte is very poisonous.
 - Do not drink electrolyte.
 - If electrolyte is swallowed, do not induce vomiting; instead, drink large amounts of water or milk followed by milk of magnesia, beaten raw eggs, or vegetable oil. Get medical attention immediately.
 - Keep children and pets away from the batteries and electrolyte.
- When not filling the batteries, keep the battery vent caps tight on the batteries. Never operate the vehicle if any of the vent caps are missing or damaged.
- When removing or installing the batteries, do not allow the battery terminals to touch any metal parts of the vehicle.
- Do not allow metal tools to short between the battery terminals and metal parts of the vehicle. Remove all jewelry and watches before servicing the batteries.
- Do not check a battery charge by placing a metal object across the posts. This will cause sparks which can cause an explosion.
- Always keep the battery retainers in place to protect and secure the batteries.
- Read and understand the charging instructions before charging the batteries; refer to Charging the Batteries, page 28. Also, take the following precautions and actions when charging the batteries:
 - Turn the vehicle On/Off switch to Off before connecting the charger to a power source.
 - Use only the battery charger supplied with the vehicle to charge the batteries.
 - Do not charge a damaged or frozen battery.

- Always unplug the AC power cord from the power outlet before unplugging it from the vehicle charging receptacle to avoid sparks.
- If during charging a battery gets hot, begins emitting large amounts of gasses, or spews electrolyte, immediately disconnect the charger power cord from the power outlet. Have the vehicle serviced by an Authorized Service Dealer before using it again.

General Maintenance

- Only permit qualified personnel to maintain, repair, adjust, or inspect the vehicle.
- Before servicing or making adjustments to the vehicle, stop the vehicle, set the parking brake, and remove the key to prevent someone from accidentally starting it.
- To make sure that the entire vehicle is in good condition, keep all nuts, bolts, and screws properly tightened.
- Do not use open pans of flammable cleaning fluids for cleaning parts.
- If major repairs are ever needed or assistance is required, contact an Authorized Toro Distributor.
- To be sure of optimum performance and safety, always purchase genuine Toro replacement parts and accessories. Replacement parts and accessories made by other manufacturers could be dangerous. Altering this vehicle in any manner that may affect vehicle operation, performance, durability, or its use, may result in injury or death. Such use could void the product warranty.

Sound Pressure Level

This unit has an equivalent continuous A-weighted sound pressure level at the operator ear of 67 dBA based on measurements of identical machines per Directive 98/37/EC and amendments.

Vibration Level

This unit does not exceed a vibration level of 2.5 m/s^2 at the hands based on measurements of identical machines per ISO 5349 procedures.

This unit does not exceed a vibration level of 0.5 m/s^2 at the posterior based on measurements of identical machines per ISO 2631 procedures.

Slope Chart

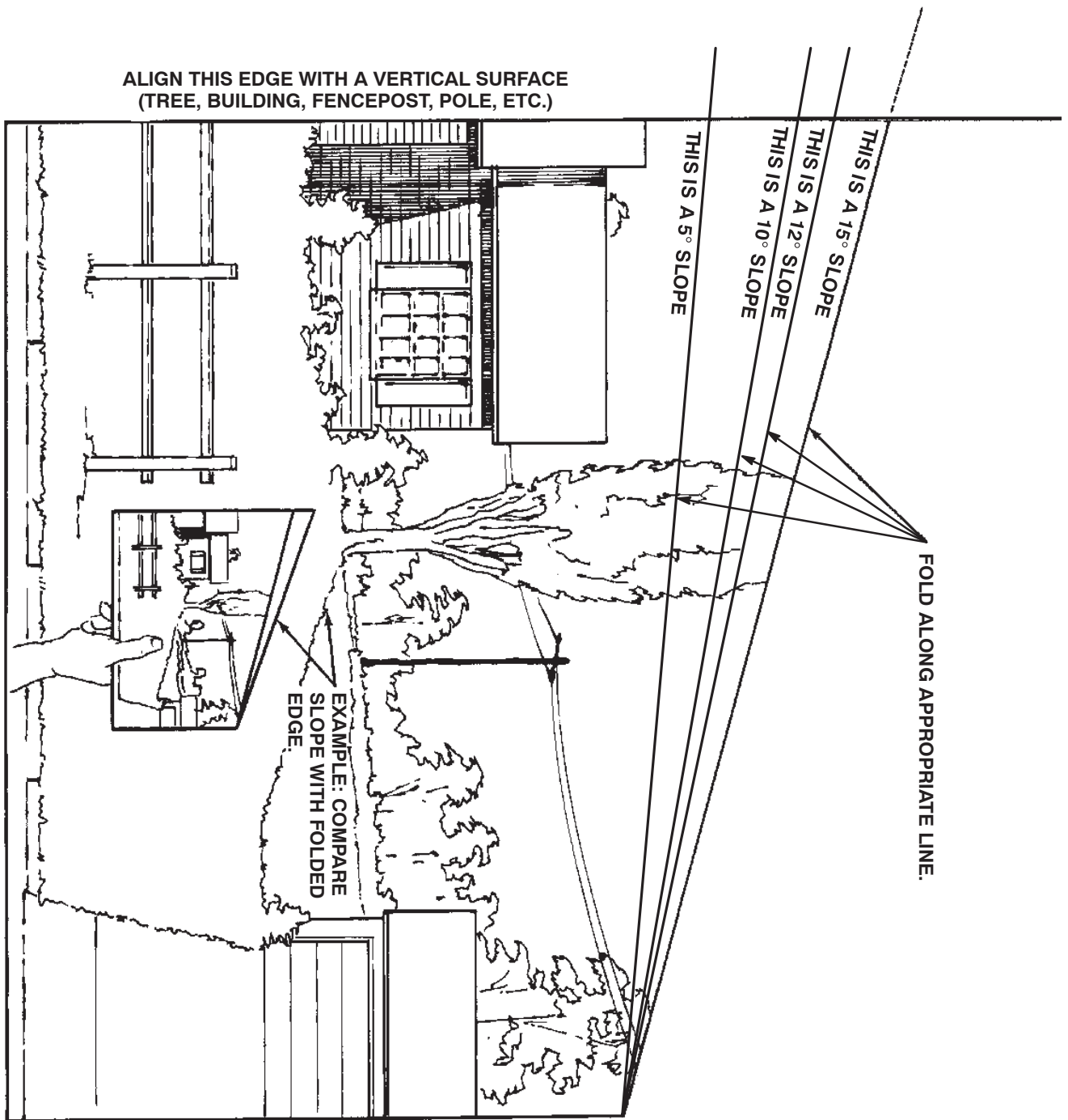

Safety and Instruction Decals



Safety decals and instructions are easily visible to the operator and are located near any area of potential danger. Replace any decal that is damaged or lost.

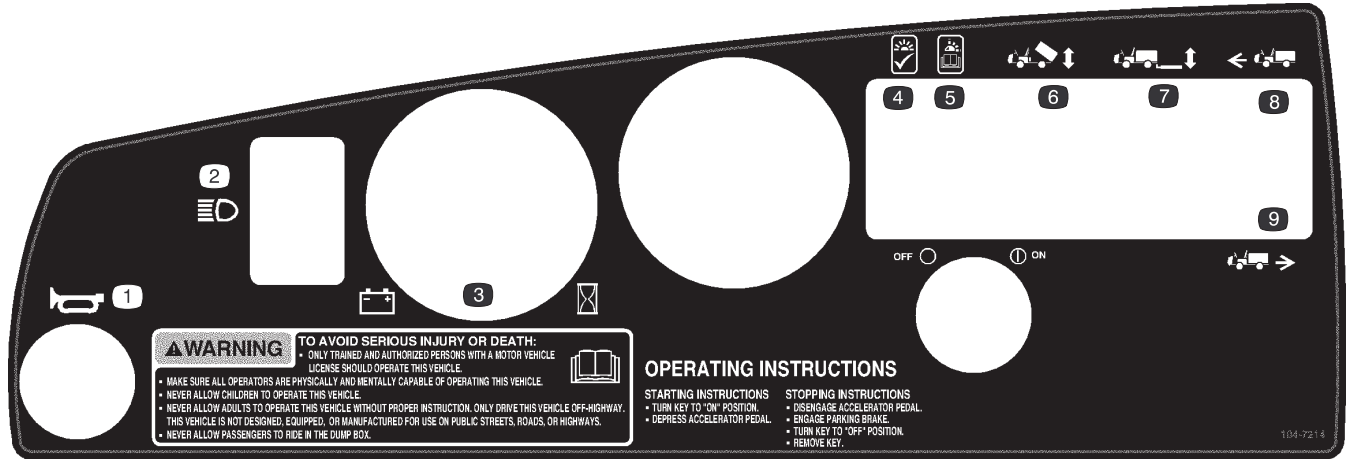

104-7214

- | | | | |
|---------------|-----------------------|--|--------------|
| 1. Horn | 3. Battery/hour meter | 5. Light blinking, read the <i>Operator's Manual</i> . | 7. Rear lift |
| 2. Headlights | 4. Light on, OK | 6. Cargo bed lift | 8. Forward |
| | | | 9. Reverse |

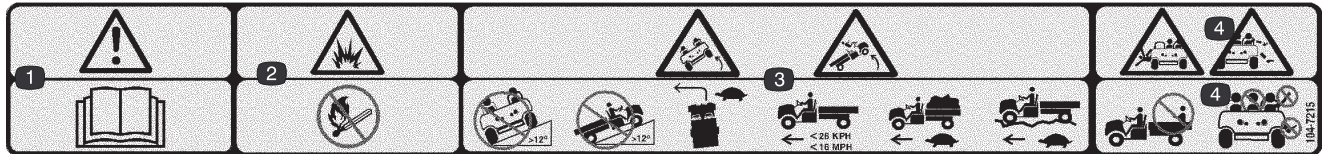

104-7215

- Warning—read the *Operator's Manual*.
- Explosion hazard—no fire, open flames, or smoking.
- Tipping hazard—do not drive the vehicle on a slope greater than 12 degrees; drive slowly when turning, when carrying a full or heavy load, and when driving on rough terrain; keep the vehicle speed under 16 mph (26 kph).
- Falling and arm/leg injury hazards—do not carry passengers in the cargo bed and keep arms and legs inside of the vehicle at all times.

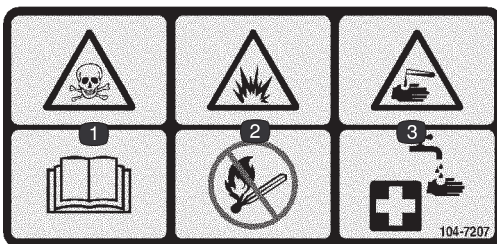

104-7207

- Poison hazard—read the *Operator's Manual*.
- Explosion hazard—no fire, open flames, or smoking.
- Caustic liquid/chemical burn hazard—to perform first aid, flush with water.

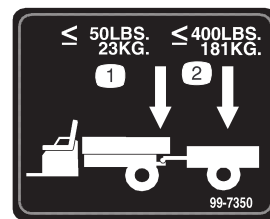

99-7350

- Maximum tongue weight is 50 lb (23 kg)
- Maximum trailer weight is 400 lb (181 kg)

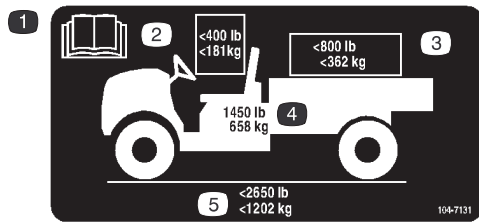

104-7131

1. Read the *Operator's Manual*.
2. The maximum combined operator and passenger weight is 400 lb (181 kg).
3. The maximum cargo weight is 800 lb (362 kg).
4. The base weight of the vehicle is 1450 lb (658 kg).
5. The maximum gross vehicle weight is 2650 lb (1202 kg).

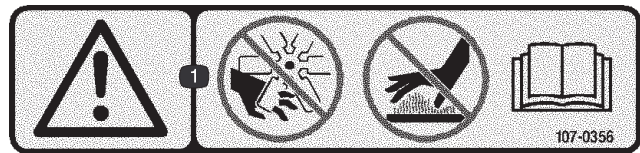

107-0356

1. Warning—Do not touch moving objects, fan; do not touch the hot surfaces; read the *Operator's Manual*.



99-7954

1. Warning—read the *Operator's Manual*.
2. Falling hazard—do not carry passengers in the cargo bed.
3. Explosion hazard, static discharge into fuel container—do not fill fuel containers in the cargo bed; place fuel containers on the ground before filling.

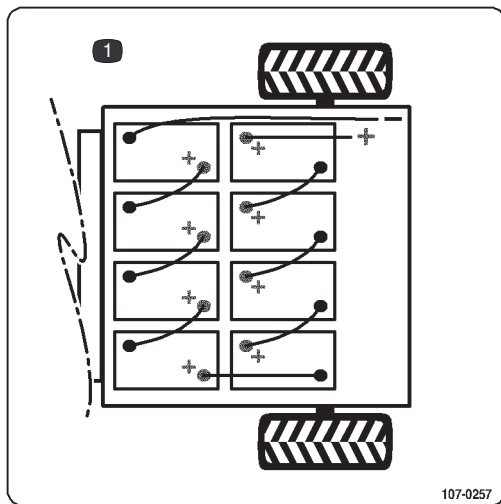

107-0257

1. Battery schematic



Battery Symbols

Some or all of these symbols are on your battery.

- | | |
|--|---|
| 1. Explosion hazard | 7. Keep bystanders a safe distance from the battery. |
| 2. No fire, open flames, or smoking. | 8. Battery acid can cause blindness or severe burns. |
| 3. Caustic liquid/chemical burn hazard | 9. Flush eyes immediately with water and get medical help fast. |
| 4. Wear eye protection; explosive gases can cause blindness and other injuries | 10. Contains lead; do not discard. |
| 5. Wear eye protection | |
| 6. Read the <i>Operator's Manual</i> . | |



107-0295

1. Warning—Read the *Operator's Manual* for more information on batteries; batteries contain lead, do not discard; disconnect the power cord from power source before driving vehicle.
2. Explosion hazard—No fire, open flames, or smoking; avoid sparks.

Specifications

Note: Specifications and design are subject to change without notice.

Base weight	Dry 1450 lb (658 kg)
Rated capacity (on level ground)	1200 lb (544.5 kg) total, including 200 lb (90.7 kg) operator and 200 lb (90.7 kg) passenger, load, trailer tongue weight, gross trailer weight, accessories, and attachments
Maximum gross vehicle weight (GVW) (on level ground)	2650 lb (1202 kg) total, including all of the weights listed above
Maximum cargo capacity (on level ground)	800 lb (362 kg) total, including trailer tongue weight and gross trailer weight
Tow capacity:	
Standard Hitch	Tongue weight 50 lb (23 kg) Maximum trailer weight 400 lb (182 kg)
Heavy Duty Hitch	Tongue weight 100 lb (45 kg) Maximum trailer weight 800 lb (363 kg)
Overall width	60 in (152.4 cm)
Overall length	119 in (302.3 cm)
Ground clearance	9-1/4 in (23.5 cm) at the front with no load or operator
Wheel base	81 in (205.7 cm)
Wheel tread (center line to center line)	49 in (124.5 cm) in the front 48-1/4 in (122.6 cm) in the rear
Cargo box length	46 in (116.8 cm) inside 51 in (129.5 cm) outside
Cargo box width	49 in (124.5 cm) inside 54 in (137.2 cm) outside
Cargo box height	10 in (25.4 cm) inside

Optional Equipment

The Toro Company has optional equipment and accessories that you can purchase separately and install on your vehicle. Contact your Authorized Service Dealer for a complete list of optional equipment that is currently available for your vehicle.

Setup

Note: Determine the left and right sides of the vehicle from the normal operating position.

Loose Parts

Note: Use the chart below to verify that all parts have been shipped.

Description	Qty.	Use
Wheel assembly	2	Installing the rear wheels
Wheel assembly	2	Installing the front wheels
Washer	2	
Dust cap	2	
Steering wheel	1	Installing the steering wheel
Bumper	1	Installing the bumper
Hitch	1	Installing the hitch
Seat	2	Installing the seats
Battery hold down	2	Installing the batteries
Battery hold down rod	2	
Battery cables	7	
Battery tray pads	4	
Battery pad	1	
Flange nut, 3/8 inch	2	
Battery terminal protector spray	1	
Cargo box	1	Installing the cargo box
Right-hand pivot bracket	1	
Left-hand pivot bracket	1	
Flange head screw, 3/8 x 1 inch	4	
Bolt, 5/16 x 3/4 inch	1	
Charger ¹	1	Setting the charger voltage.
Key	2	Use in the On/Off switch.
Supervisor Speed Limit Switch Key	2	Use in the supervisor speed limit switch.
Operator's Manual	1	Read before operating the vehicle.
Operator Video	1	Watch before operating the vehicle.
Parts Catalog	1	Use for ordering replacement parts.
Predelivery Inspection Form	1	Complete and file in your customer history portfolio.

¹Refer to the *Parts Manual* for the available power cords for the voltage used in the region or country where operating the charger. Contact your Authorized Toro Dealer to obtain the appropriate power cord.

Installing the Rear Wheels

1. Remove the fasteners securing the wheels.
2. Remove the shipping bracket secured to the wheel studs.
3. Mount the wheels with the previously removed fasteners (Fig. 2) and torque to 45–65 ft-lb (61–88 N·m).

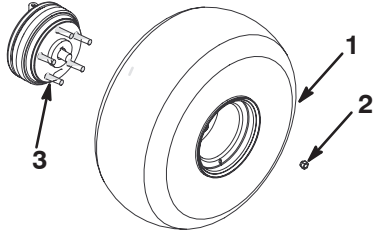

Figure 2

- | | |
|-------------------|---------------|
| 1. Wheel assembly | 3. Wheel stud |
| 2. Wheel nut | |

Installing the Front Wheels

1. Remove the fasteners securing the wheels.
2. Remove the shipping bracket from the spindles.
3. Apply Loctite (blue) to the screw threads.
4. Mount the wheels with the previously removed fasteners (Fig. 3) and torque the bolts to 135–165 ft-lb (183–224 N·m).

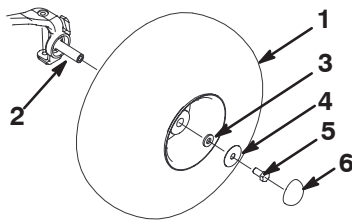

Figure 3

- | | |
|----------------------------|-----------------|
| 1. Tire and wheel assembly | 4. Large washer |
| 2. Spindle | 5. Screw |
| 3. Small washer | 6. Dust cap |

Installing the Steering Wheel

1. Remove the nut and lock washer from the steering shaft.
2. Slide the steering wheel and washer onto the shaft. Position the steering wheel on the shaft so that the cross beam is horizontal when the tires are pointed straight ahead and the thicker spoke of the steering wheel is downward.
3. Secure the steering wheel to the shaft with the nut (Fig. 4).

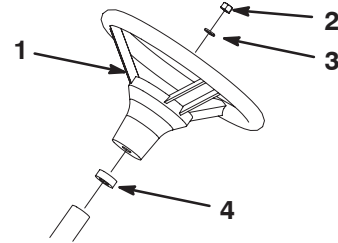

Figure 4

- | | |
|-------------------|--------------|
| 1. Steering wheel | 3. Washer |
| 2. Nut | 4. Foam seal |

Installing the Bumper

1. Remove the 2 bolts, washers, and nuts secured to the front of the frame.
2. Align the mounting holes and secure the bumper to the frame with the fasteners previously removed (Fig. 5).

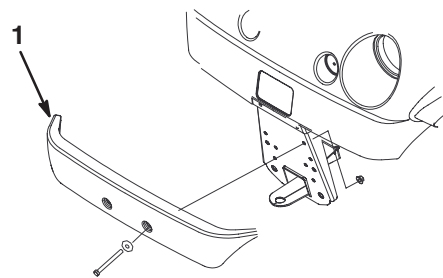

Figure 5

- | |
|-----------|
| 1. Bumper |
|-----------|

Installing the Seats

Insert the seat bracket into the seat base opening and pivot the seat downward (Fig. 6).

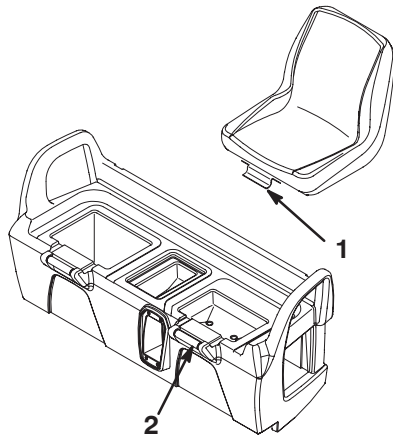

Figure 6

1. Seat bracket
2. Seat base

Installing the Hitch

1. Remove the 4 bolts and nuts from the inside rear of the frame.
2. Align the hitch with the mounting holes on the frame. Secure the hitch with the screws and nuts (Fig. 7).

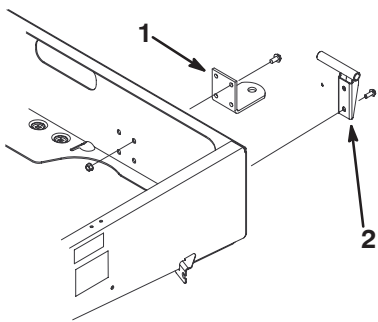

Figure 7

1. Hitch
2. Left pivot bracket

Installing the Batteries

Toro recommends the use of either Trojan T105 or T145, or US. Battery US2200 or US145.

Battery Specification: 6V 225AH @ 20hr rate
Dimensions: (LxWxH) (10-1/4 x 7-1/8 x 11-1/4 inches)

1. Turn the key switch to the Off position and remove the key.

2. Install the battery tray pads into the rear frame assembly as shown Figure 8.

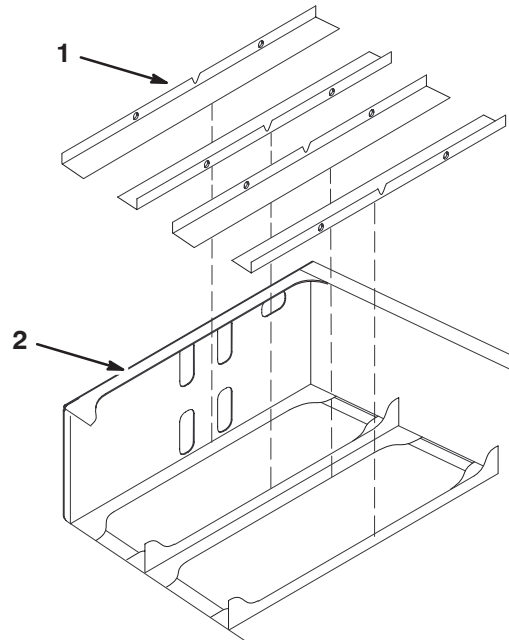

Figure 8

1. Battery tray pads
2. Rear frame assembly

m-7647

3. Remove the adhesive strip from the back of the battery pad and install it to the front inside face of the rear frame as shown in Figure 9.

Note: The pad should be approximately 1/4 inch below the bottom edge of the upper set of cut-out holes (Fig. 9).

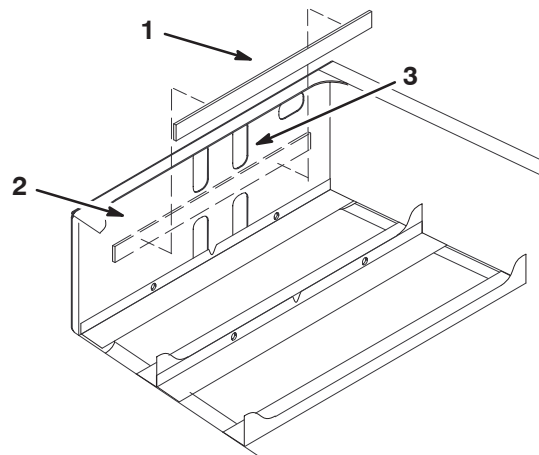

Figure 9

1. Battery pad
2. Front inside face
3. Upper cut-out holes

m-7646

4. Install the batteries as shown in Figure 10.

Note: Pay attention to the battery polarity when installing the new batteries (Fig. 10).

Warning

Incorrect battery cable routing could damage the vehicle and cables causing sparks. Sparks can cause the battery gasses to explode, resulting in personal injury.

- Always ensure the battery polarity when making connections.

Caution

Batteries can give you a powerful electrical shock.

- Use tools with plastic handles or wrap the handles of metal tools with electrical tape.
- Be careful not to contact both a positive terminal and a negative terminal at the same time.

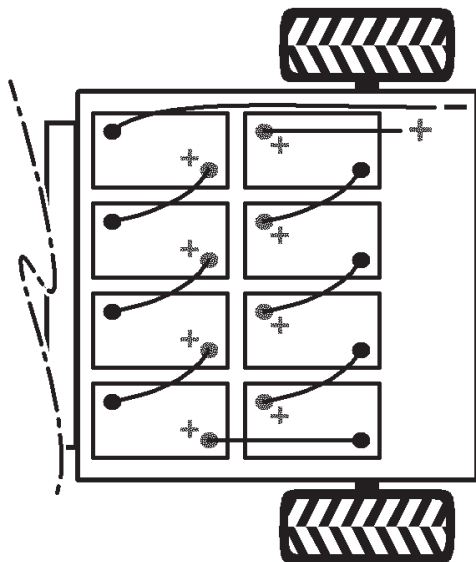

Figure 10

5. Install the battery retainers and torque the nuts to 150 to 200 in-lb (17 to 22 N·m).
6. Connect the batteries together with the battery cables included in loose parts, as illustrated in Figure 10. Ensure the cable routing does not allow cables to contact any sharp edges.

Important Check all high current battery connections to ensure they have been properly secured.

7. Connect the long, red, main positive lead between the bank of batteries and the vehicle (Fig. 10).
8. Connect the long, black, main negative lead between the bank of batteries and the vehicle (Fig. 10).

Warning

Loose or improperly secured battery connections could damage the vehicle and cables causing sparks. Sparks can cause the battery gasses to explode, resulting in personal injury.

- Always ensure the battery polarity when making connections.

9. Torque the nuts securing all battery cables to 120 to 180 inch-lb (13.5 to 21 N·m).
10. Coat the battery terminals with Toro battery terminal protector.
11. Ensure that the rubber boots on each battery cable are securely seated over the battery terminals.

Installing the Cargo Box

1. Position the cargo box onto the frame. The cargo box must lay flat and be centered.
2. Mount the left hand pivot bracket to the left rear corner of the frame with 2 flange head screws (3/8 x 1 inch). Torque the screws to 16 ft-lb (22 N·m). (Position the bracket as shown in Figure 7.
3. Slide the cargo box mounting hole onto the pivot bracket (Fig. 11).

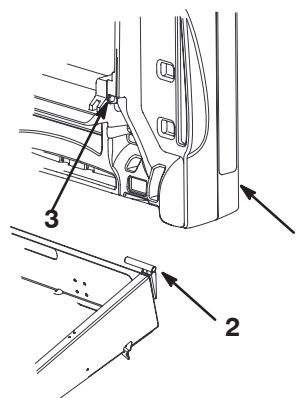

Figure 11

1. Cargo box
2. Pivot bracket
3. Cargo box mounting hole

4. Insert the right hand pivot bracket into the mounting hole in the cargo box and then mount it to the frame. Torque the screws to 16 ft-lb (22 N·m).
5. Have another person help to raise the cargo box.
6. Loosen the bolt securing the prop rod clip to the frame until you can slide the J-hook end of the prop rod under the clip (Fig. 12).

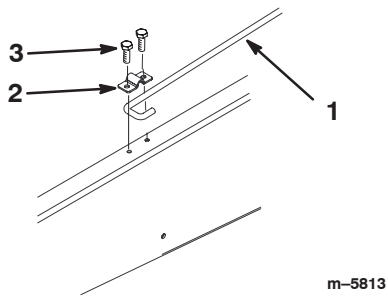

Figure 12

- 1. Prop rod
- 2. Prop rod clip
- 3. Bolt, 5/16 x 3/4 inch

- 7. Tighten the bolt and secure the other side of the clip with a new bolt (5/16 x 3/4 inch) (Fig. 12).
- 8. Lower the cargo box.

Checking the Tire Pressure

Check the tire pressure every 8 hours or daily to ensure proper levels.

The air pressure range in the front and rear tires is 8–22 psi (55–152 kPa).

The air pressure needed is determined by the payload carried. **Lower** air pressure will provide less compaction, a smoother ride, and fewer tire marks. Lower pressure should not be used for heavy payloads at high speeds.

Higher pressures should be used for heavier payloads at higher speeds. Do not exceed the maximum pressure.

Setting the Charger Voltage

Important The incorrect voltage setting on the battery charger can impair function and damage the charger. Always make sure the charger voltage setting matches the voltage used to power the charger.

- 1. Locate the voltage selector on the rear of the charger (Fig. 13).
- 2. Adjust the voltage setting by moving the switch on the voltage selector upward or downward to change the voltage setting (Fig. 13).

The setting is displayed in the window above the selector.

Note: Use the 100V setting for voltages ranging from 100V to 120V.

Always use the appropriate power cord for the power outlet of the country or region charging will occur. Contact your Authorized Toro Dealer to obtain the correct power cord if necessary.

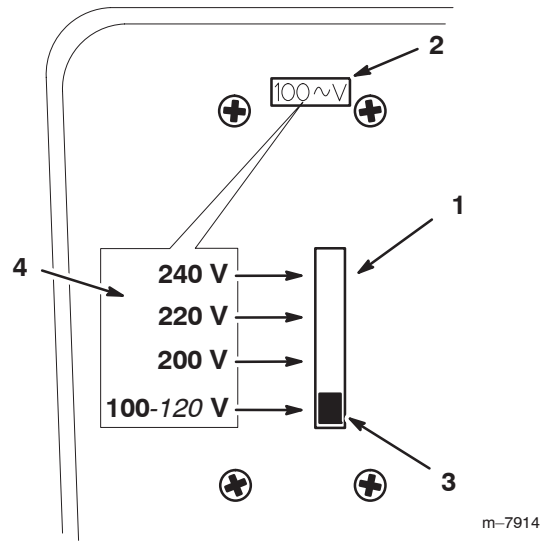

Figure 13

Rear of charger

- 1. Voltage selector
- 2. Voltage setting window
- 3. Switch
- 4. Voltages by switch position

Operation

Note: Determine the left and right sides of the vehicle from the normal operating position.

Think Safety First

Carefully read all of the safety instructions and decals in the safety section. Knowing this information could help you or bystanders avoid injury.

Controls

Accelerator Pedal

The accelerator pedal (Fig. 14) gives you the ability to vary ground speed of the vehicle. Pressing the pedal when the On/Off switch is on starts the motor. Pressing the pedal farther increases ground speed. Releasing the pedal will slow the vehicle and the motor will stop running.

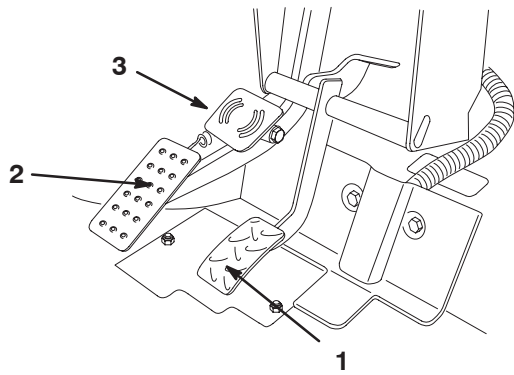

Figure 14

- 1. Accelerator pedal
- 2. Brake pedal
- 3. Parking brake

m-7966

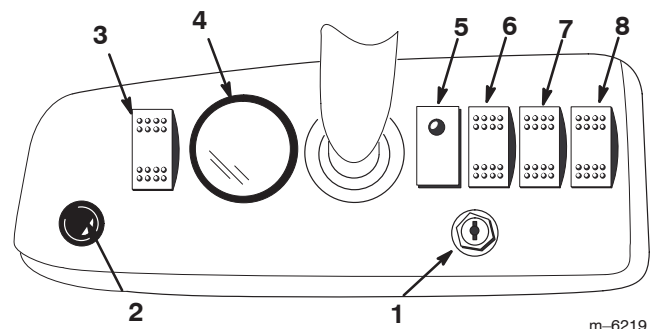

Figure 15

- 1. On/Off switch
- 2. Horn button
- 3. Light switch
- 4. Battery/hour meter
- 5. Vehicle status light
- 6. Power cargo bed switch (optional)
- 7. Rear lift switch (optional)
- 8. Vehicle direction switch

m-6219

Brake Pedal

Use the brake pedal to stop or slow the vehicle (Fig. 14).

⚠
Caution
⚠

Brakes can become worn or can be misadjusted resulting in personal injury.

If brake pedal travels to within 1 inch of the vehicle floor board, the brakes must be adjusted or repaired.

Parking Brake

The parking brake is a small plate at the top of the brake pedal (Fig. 14). Whenever you stop the vehicle, engage the parking brake to prevent accidental movement of the vehicle. To engage the parking brake, step on the brake pedal firmly and roll forward with the top of your foot. To disengage, press the accelerator or brake pedal. If the vehicle is parked on a steep grade, apply the parking brake and place blocks on the downhill side of the wheels.

On/Off Switch

The On/Off switch (Fig. 15), used to activate the electrical systems of the vehicle, has two positions: Off and On. Rotate the key clockwise to the On position to allow operation of the vehicle and accessories. After stopping the vehicle, rotate the key counterclockwise to the Off position. Remove the key before leaving the vehicle.

Horn Button

Press the horn button to activate the vehicle horn (Fig. 15).

Battery/Hour Meter

The battery/hour meter provides you with an indication of how much charge is contained in the batteries (Fig. 15 and 19) and the number of operating hours on the vehicle. The battery meter is located at the top of the LCD screen. When the vehicle batteries are fully charged, ten bars extend from the 0 to the 1 position. As the charge is used, bars disappear starting on the right side. For detailed information on the battery meter, refer to Understanding and Using the Battery System; page 21.

The hour meter is located at the bottom of the LCD screen. It logs operating hours whenever the key is in the On position and the vehicle is in motion.

Vehicle Direction Switch

Use this switch (Fig. 15) to toggle between forward and reverse operation.

Vehicle Status Light

This light communicates the status of the vehicle as determined by the on board computer. Always check this light when you turn the On/Off switch to the On position (Fig. 15). The light flashes at various intervals for different problems and events. When there are no problems and the vehicle is operational, the light is on. If the light blinks, refer to Troubleshooting, page 37, for a description of the flash codes.

Light Switch

Use this switch to turn the headlights on and off (Fig. 15).

Cargo Bed Lift Switch (Optional)

Use this switch to raise and lower the cargo bed (Fig. 15).

Rear Lift Switch (Optional)

Use this switch to raise and lower the rear lift (Fig. 15).

Supervisor Speed Limit Switch

The supervisor speed limit switch, located under the cup holder (Fig. 16), has two positions: Off and On. Rotate the key clockwise to the On position to limit the maximum vehicle speed to a factory setting of 12 mph (19 kph). Rotate the key counterclockwise to the Off position to restore the maximum speed of the vehicle.

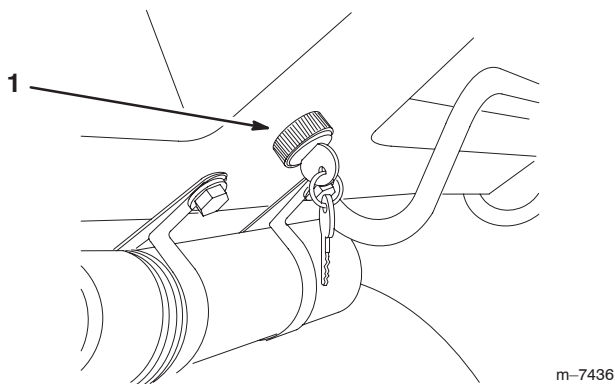

Figure 16

1. Supervisor speed limit switch

Passenger Hand Holds

The passenger hand holds are located on the right side of the dash panel and at the outside of each seat (Fig. 17).

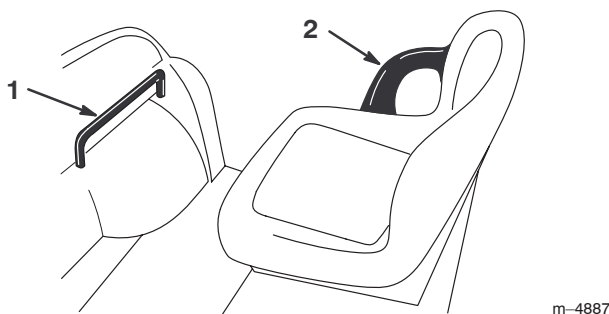

Figure 17

1. Passenger hand hold
2. Hip restraint

Pre-Operating Checks

Check the following items each time you begin using the vehicle for the day:

- Check the tire pressure.
- Check the brake pedal operation.
- Check to see that the lights are working.
- Turn the steering wheel to the left and right to check steering response.
- Check for loose parts and any other noticeable malfunctions. Make sure the vehicle is off and all moving parts have stopped before checking for loose parts and other malfunctions.

If any of the above items are not correct, notify your mechanic or check with your supervisor before taking the vehicle out for the day. Your supervisor may want you to check other items on a daily basis, so ask what your responsibilities are.

Operating the Vehicle

1. Disconnect the battery charger.
2. Sit in the operator's seat, insert the key into the On/Off switch, and rotate the key clockwise to the On position.
3. Move the vehicle direction switch button to the desired position.
4. Slowly step on the accelerator pedal to drive the vehicle.

Note: The parking brake will automatically disengage when you press the accelerator pedal.

Stopping the Vehicle

Important When stopping the vehicle on an incline, use the brake to stop the vehicle and the parking brake to hold it in place. Using the accelerator to stall the vehicle can damage the vehicle.

To stop the vehicle, remove your foot from the accelerator pedal and slowly press the brake pedal.

Note: Stopping distance may vary depending on the vehicle load and speed.

Parking the Vehicle

1. Engage the parking brake and rotate the On/Off key to Off.
2. Remove the key from the switch to prevent accidental starting.

Understanding and Using the Battery System

Understanding Deep Cycle Batteries

The vehicle contains 8 deep cycle, lead-acid batteries which supply power to the motor and accessories. A deep cycle battery is not the same as an automobile battery. An automobile battery is designed to provide a surge of power to start the vehicle and moderate power to run the lights and accessories when the engine is off or idling. The alternator then continuously recharges it as the automobile runs. As such, an automobile battery seldom drops below 90% of maximum charge level.

A deep cycle battery is designed to be a primary power source to provide a sustained output. Deep cycle batteries are typically discharged as low as 20% to 30% of the maximum charge level. A discharge this low is considered a deep discharge.

Lead acid batteries produce electricity through a chemical reaction between coated lead plates and sulfuric acid. Charging a battery reverses the chemical reaction, allowing the battery to once again produce electricity.

A battery is a perishable item that has a limited life time (Fig. 18). When a battery is new, it requires a break-in period to establish efficient electrical production. This break in period usually requires 20 to 50 discharge/charge cycles.

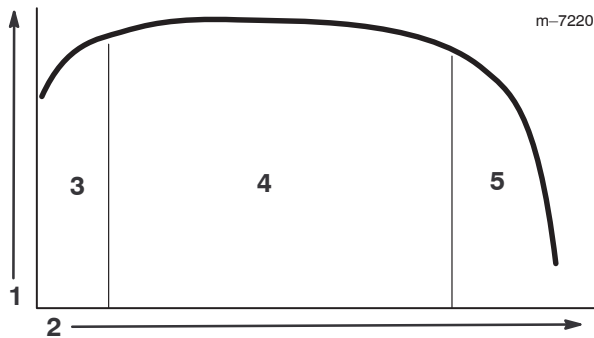

Figure 18

- | | |
|--------------------------------------|------------------------|
| 1. Battery capacity | 4. Prime battery life |
| 2. Discharge/charge cycles | 5. End of battery life |
| 3. Break-in period (20 to 50 cycles) | |

After the break-in period, the battery will maintain a high capacity for many cycles. The number of cycles a battery will perform is dependant on the following:

- Battery maintenance—improper maintenance will severely reduce the life of the batteries.
- Depth of discharge between charge cycles—**the deeper the batteries are discharged on a regular basis between charges, the less life they will have.**

- Recharge frequency—charge the batteries whenever they are not in use. **Fully discharging the batteries will damage them and reduce their life.**

At the end of the battery life, the coating on the lead plates begins to deteriorate, causing the batteries to rapidly lose electric capacity.

Using the Battery System

When your batteries are fully charged, the battery meter will have ten bars showing from left to right (Fig. 19).

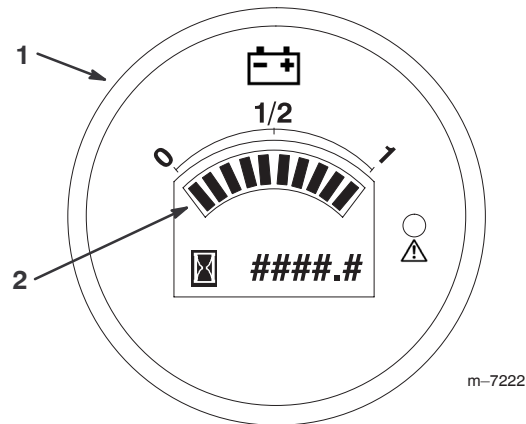

Figure 19

- | | |
|-----------------------|--------------------------|
| 1. Battery/hour meter | 2. Charge indicator bars |
|-----------------------|--------------------------|

As you use the vehicle, the bars will disappear as the electrical capacity of the batteries is used.

When only 2 bars are left, the red warning light on the meter will illuminate and the battery icon will begin flashing on the screen (Fig. 20). This indicates that the battery capacity is nearly drained and you should charge the batteries as soon as possible to prevent battery damage.

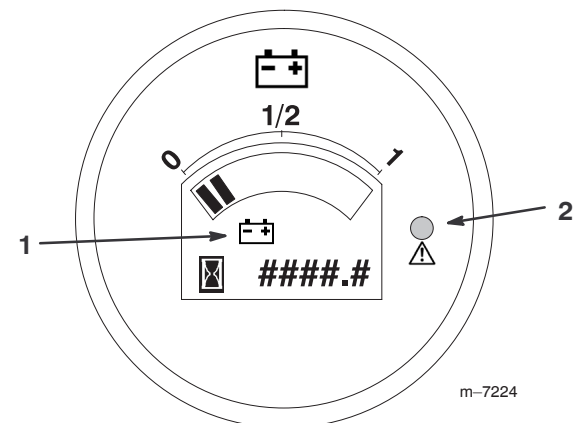

Figure 20

- | | |
|-----------------|---------------------|
| 1. Battery icon | 2. Warning light—on |
|-----------------|---------------------|

When only one bar is left, the warning light will begin flashing and the vehicle will go into an energy saving mode (Fig. 21). In this mode, the vehicle will only drive at 3 mph. Recharge the batteries immediately to prevent serious damage to them.

If the batteries become fully discharged, the vehicle will shut down. **Do not allow the batteries to become fully discharged.**

Important To obtain maximum battery life, always charge the batteries when there are 2 or more bars visible on the screen. Depleting the batteries lower than 2 bars, especially on a regular basis, will reduce the life of the batteries.

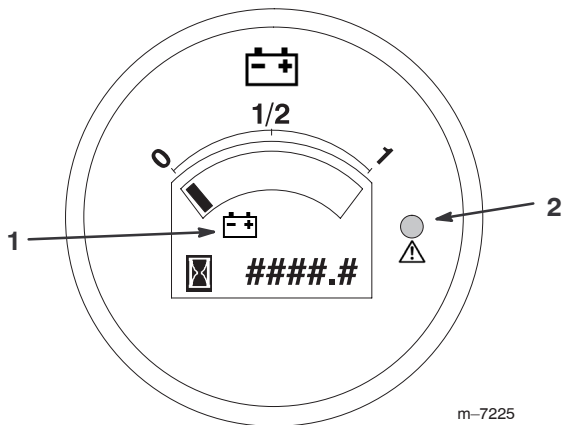

Figure 21

1. Battery icon
2. Warning light—flashing

Operating the Cargo Box

Raising the Box

! **Warning** !

Driving the vehicle with the cargo box raised may cause the vehicle to tip or roll easier. The box structure may become damaged if the box is raised for an extended period of time while operating the vehicle.

- Only operate the vehicle when the cargo box is down.
- After a load has been dumped, lower the cargo box.

1. Lift the lever on either side of the box and lift the box up (Fig. 22).

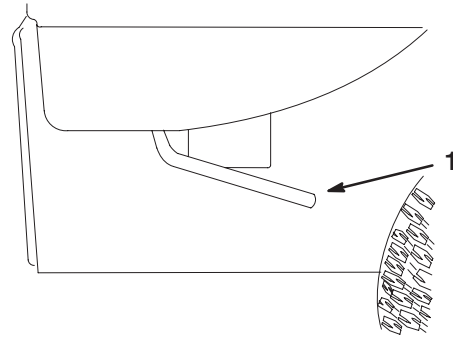

Figure 22

1. Lever
2. Pull the prop rod into the detent slot, securing the box (Fig. 23).

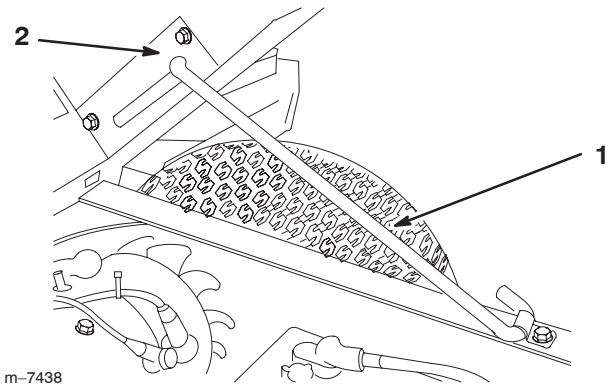

Figure 23

1. Prop rod
2. Detent slot

Lowering the Box

! **Warning** !

The weight of the box may be heavy. Hands or other body parts could be crushed.

Keep hands and other body parts clear when lowering the box.

Pull the prop rod out of the detent slot and lower the box until it latches in place.

Adjusting the Box Latches

If the box does not latch tightly, vibrating up and down as you drive the vehicle, you can adjust the latch posts to make the latches fit snugly.

1. Loosen the nut on the end to the latch post (Fig. 24).

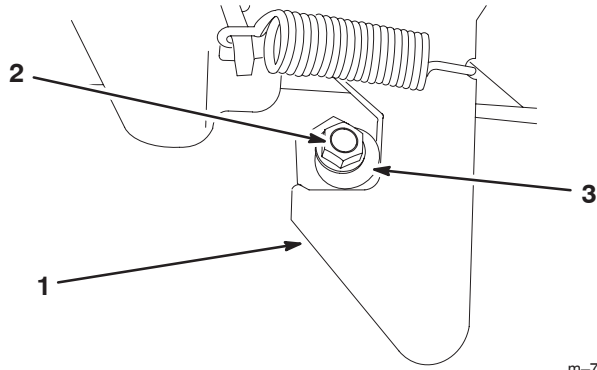

Figure 24

- | | |
|----------|---------------|
| 1. Latch | 3. Latch post |
| 2. Nut | |

2. Turn the latch post clockwise until it is snug against the latch and then tighten the nut (Fig. 24).
3. Repeat this procedure for the latch on the other side of the vehicle.

Opening and Closing the Tailgate Latches

1. To open the tailgate latches, lift the latch handles up (Fig. 25). The latches will spring out toward the center of the tailgate. Slowly lower the tailgate.

Note: You may need to push the end of the tailgate in (especially if there is a load against the tailgate) before the latches will spring toward the center of the tailgate and release.

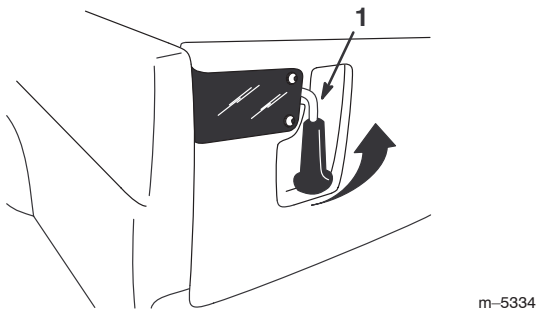

Figure 25

1. Tailgate latch

2. To close the tailgate latches, lift the handles upward and slide them toward the outside of the vehicle.
3. Push the latch handles downward to secure the latch and tailgate.

Breaking-in a New Vehicle

To provide proper performance and long vehicle life, follow these guidelines for the first 100 operating hours:

New deep-cycle batteries do not reach their maximum charge capacity until they have been cycled 20 to 50 times (i.e., charged and discharged). Therefore, you will notice that new batteries will not run as long as batteries that have been broken-in. This is normal and not a cause for concern.

- Avoid hard braking situations for the first several hours of new vehicle break-in operation. New brake linings may not be at optimum performance until several hours of use has caused the brakes to become burnished (broken-in).
- Refer to the Maintenance section for any special low hour checks.
- Check the front suspension positioning and adjust it if necessary; refer to Adjusting the Front Suspension, page 32.

Loading the Cargo Box

The capacity of the cargo box is 13 ft³ (0.37 m³). The amount (volume) of material that can be placed in the box without exceeding the vehicle load ratings can vary greatly depending on the density of the material. For example, a level box of wet sand weighs 1500 lb (680 kg), which greatly exceeds the load rating.

See the table below for load volume limits with various materials:

Material	Density (lb/ft ³)	Approximate max. cargo box capacity (on level ground)
Gravel		
Dry	95	1/2 full
Wet	120	1/3 full
Sand		
Dry	90	1/2 full
Wet	120	1/3 full
Wood	45	Full
Bark	<45	Full
Earth, packed	100	1/2 full

Transporting the Vehicle

For moving the vehicle long distances, a trailer should be used. Make sure that the vehicle is secured to the trailer. Refer to Figures 26 and 27 for the location of the tie down points.

Caution

Loose seats may fall off of the vehicle and trailer when transporting and land on another vehicle or become an obstruction on the road.

Remove the seats or make sure that the seats are securely fastened in the detents.

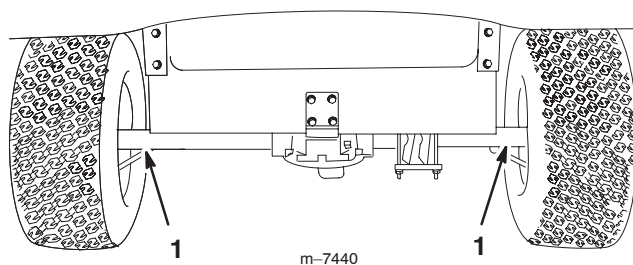

Figure 26

1. Tie down points

Towing the Vehicle

In case of an emergency, the vehicle can be towed at a slow speed for a short distance. However, we do not recommend this as a standard procedure.

Important Towing the vehicle more than 5 mph will damage the motor.

Warning

Towing at excessive speeds could cause a loss of steering control, resulting in personal injury.

Never tow the vehicle faster than 5 MPH.

Towing the vehicle is a two person job (one needs to drive the towing vehicle and one needs to steer this vehicle). If the vehicle must be moved a considerable distance, transport it on a truck or trailer; refer to Transporting the Vehicle, page 24.

1. Turn off the On/Off switch and remove the key.
2. Affix a tow line to the tongue on the front frame member (Fig. 27).
3. Release the parking brake.

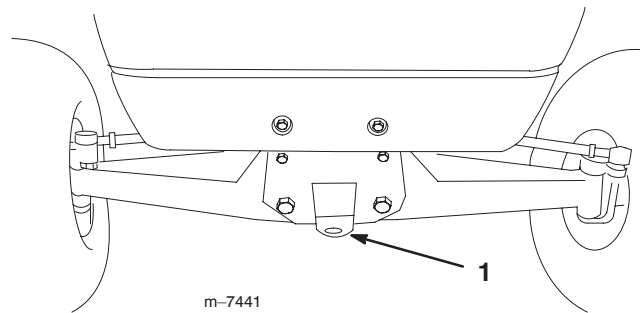

Figure 27

1. Towing tongue and tie down point

Towing a Trailer

The vehicle is capable of pulling trailers. Two types of tow hitches are available for the vehicle, depending on your application. Contact your Authorized Toro Distributor for details.

When hauling cargo or towing a trailer, do not overload your vehicle or trailer. Overloading can cause poor performance or damage to the brakes, axle, motor, transaxle, steering, suspension, body structure, or tires. Always load a single axle trailer with 60% of the cargo weight in the front of the trailer. This places approximately 10% of the Gross Trailer Weight (GTW) on the tow hitch of the vehicle.

The maximum cargo load shall not exceed 800 lb (362 kg), including the GTW and tongue weight. For example, if the GTW = 200 lb and tongue weight = 50 lb, then the maximum cargo load = 550 lb.

To provide adequate braking and traction, always load the cargo box when trailering. Do not exceed the GTW limits.

Avoid parking a vehicle with a trailer on a hill. If you must park on a hill, engage the parking brake and block the trailer tires.

Maintenance

Recommended Maintenance Schedule

Maintenance Service Interval	Maintenance Procedure
When not in use	<ul style="list-style-type: none">• Charge the batteries.
Every 8 hours	<ul style="list-style-type: none">• Check the tire pressure.
After first 20 hours	<ul style="list-style-type: none">• Check the front wheel toe-in at the proper ride height.
Every 25 hours	<ul style="list-style-type: none">• Check the battery electrolyte level.• Check the battery cable connections.• Clean the batteries.
Every 100 hours	<ul style="list-style-type: none">• Lubricate all grease fittings.• Inspect the brake and parking brake.• Inspect the condition and wear of the tires.• Torque the wheel lug nuts.• Check the front suspension toe-in and ride height.• Check the transaxle oil level.
Every 200 hours	<ul style="list-style-type: none">• Check the brake cable adjustments.

Duplicate this page for routine use.



Maintenance Check Item	For the week of:						
	Mon.	Tues.	Wed.	Thurs.	Fri.	Sat.	Sun.
Charge the batteries.							
Check the brake and parking brake operation.							
Check any unusual operating noises.							
Check the tire pressure.							
Check for fluid leaks.							
Check the instrument operation.							
Check the accelerator operation.							
Check ride height and toe-in.							
Lubricate all grease fittings. ¹							
Touch up any damaged paint.							

¹Immediately after **every** washing, regardless of the interval listed

Notation for Areas of Concern

Inspection performed by:		
Item	Date	Information
1		
2		
3		
4		
5		
6		
7		
8		
9		
10		
11		
12		
13		

Note: Determine the left and right sides of the vehicle from the normal operating position.

 Warning 
<p>The bed must be raised to perform some routine maintenance. The bed could fall and injure persons that are underneath it.</p> <p>Remove any load material from bed before working under raised bed.</p>



Caution



If you leave the key in the On/Off switch, someone could accidentally start the vehicle and seriously injure you or other bystanders.

Remove the key from the On/Off switch before you do any maintenance.

Heavy Duty Operation

Important If the vehicle is subjected to any of the conditions listed below, maintenance should be performed twice as frequently:

- Desert operation
- Cold climate operation (below 32 degrees F)
- Trailer towing
- Frequent operation on dusty roads
- Construction work
- After extended operation in mud, sand, water, or similar dirty conditions, have your brakes inspected and cleaned as soon as possible. This will prevent any abrasive material from causing excessive wear.
- Under frequent heavy duty operating conditions, lubricate all grease fittings.

Jacking the Vehicle

Whenever the motor is run for routine maintenance and/or diagnostics, the rear wheels of the vehicle should be 1 inch (25 mm) off of the ground with the rear axle supported on jack stands.



Danger



A vehicle on a jack may be unstable and slip off of the jack, injuring anyone beneath it.

- Do not start the vehicle while the vehicle is on a jack.
- Always remove the key from the switch before getting off of the vehicle.
- Block the tires when the vehicle is on a jack.

The jacking point at the front of the vehicle is on the front of the frame behind the towing tongue (Fig. 28). The jacking point at the rear of the vehicle is under the axle tubes (Fig. 29).

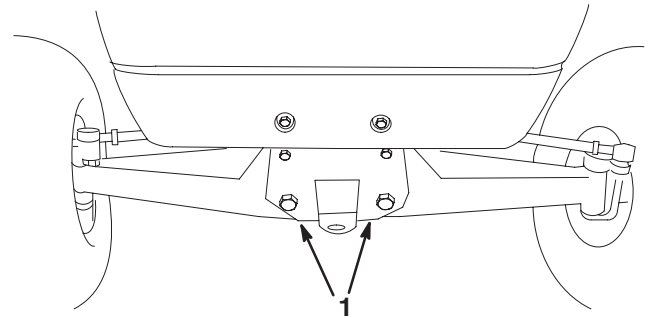

m-7442

Figure 28

1. Front jacking points

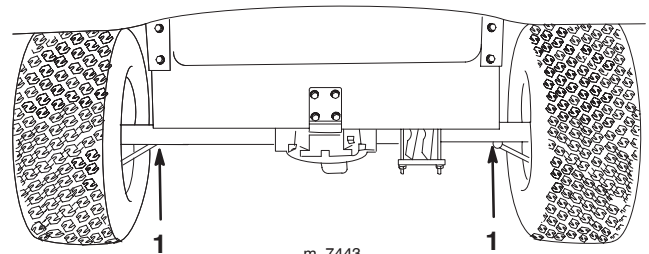

m-7443

Figure 29

1. Rear jacking points

Maintaining the Batteries

Warning

Battery terminals or metal tools could short against metal vehicle components causing sparks. Sparks can cause the battery gasses to explode, resulting in personal injury.

- When removing or installing the battery, do not allow the battery terminals to touch any metal parts of the vehicle.
- Do not allow metal tools to short between the battery terminals and metal parts of the vehicle.
- Always keep the battery retainers in place to protect and secure the batteries.

Warning

CALIFORNIA
Proposition 65 Warning

Battery posts, terminals, and related accessories contain lead and lead compounds, chemicals known to the State of California to cause cancer and reproductive harm. *Wash hands after handling.*

Cleaning the Batteries

Clean the batteries daily.

1. Ensure that all of the battery caps are tight.
2. Use a paper towel to clean the batteries.
3. If the battery terminals are corroded, clean them with a solution of four parts water and one part baking soda. Also, clean the posts and cable clamps with a post and clamp cleaner. The posts and clamps should have a bright metallic shine.
4. Apply a light coating of Toro battery terminal protector.

Setting the Charger Voltage

Important The incorrect voltage setting on the battery charger can impair function and damage the charger. Always make sure the charger voltage setting matches the voltage used to power the charger.

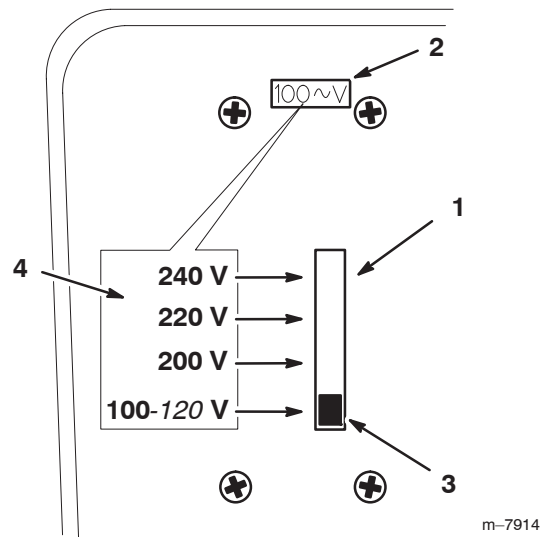

Figure 30

Rear of charger

1. Voltage selector
2. Voltage setting window
3. Switch
4. Voltages by switch position

Locate the voltage selector on the rear of the charger. Adjust the voltage setting by moving the switch on the voltage selector upward or downward to change the voltage setting (Fig. 30) The setting is displayed in the window above the selector.

Note: Use the 100V setting for voltages ranging from 100V to 120V.

Always use the appropriate power cord for the power outlet of the country or region charging will occur. Contact your Authorized Toro Dealer to obtain the correct power cord if necessary.

Charging the Batteries

Always keep the charger in a dry location. For maximum battery life, charge the batteries whenever you are not using the vehicle. Depending on how discharged the batteries are, it may take up to 16 hours to charge the batteries to full capacity.

Important Lead-acid batteries do not develop a charge memory and do not need to be fully discharged before charging them. **Fully discharging the batteries may damage them.** Charge the batteries whenever the vehicle gets low on power and any time it is not in use; refer to Using the battery System, page 21.

Warning

Charging the battery produces gasses that can explode.

Never smoke near the batteries and keep sparks and flames away from them.

1. Position the vehicle in a well ventilated area near a power outlet.
2. Connect the charger cord to the charging receptacle on the vehicle (located on the panel between the seats).
3. Plug the charger power cord into a outlet.
 - While the batteries are charging, the green light on the charger will blink on and off. When the batteries are fully charged, the green light stops blinking and stays on.
4. Disconnect the power cord from the power outlet.
5. Disconnect the charger from the vehicle.

Important Do not carry the charger on the vehicle. Excessive or prolonged jarring may damage it.

Adding Water to the Batteries

Check the electrolyte level and add water if needed every 25 operating hours or, if the vehicle is in storage, every 30 days. **Use only clean, distilled water to fill the batteries.**

Danger

Battery electrolyte contains sulfuric acid which is a deadly poison and causes severe burns.

- **Do not drink electrolyte and avoid contact with skin, eyes or clothing. Wear safety glasses to shield your eyes and rubber gloves to protect your hands.**
- **Fill the batteries where clean water is always available for flushing the skin.**
- **Never add acid to a battery.**

1. Raise the cargo bed, turn the key off, and remove it.
2. Remove the filler caps from each battery.
3. If the electrolyte is not over the top of the plates in each battery cell, add just enough distilled water to cover the plates.

4. Replace the filler caps on all batteries.
5. Charge the batteries for 16 hours; refer to Charging the Batteries, page 28.
6. Remove the filler caps from each battery.
7. Add just enough distilled water to bring the electrolyte level to 1/8 inch (3 mm) below the bottom of each fill well (Fig. 31).

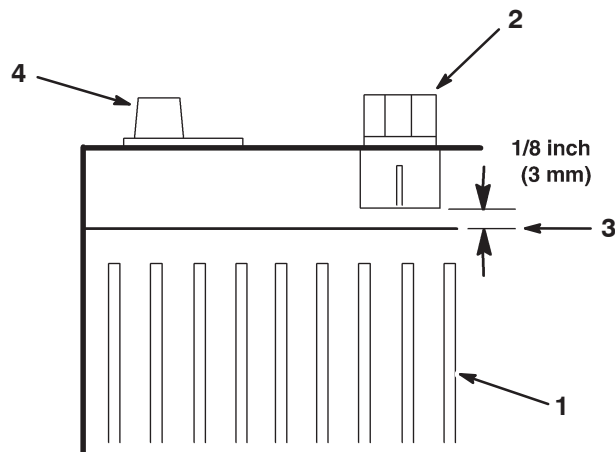

Figure 31

- | | |
|-------------------|----------------------|
| 1. Battery plates | 3. Electrolyte level |
| 2. Filler cap | 4. Battery terminal |

Important Do not overfill the battery. Electrolyte will overflow onto other parts of the vehicle and severe corrosion and deterioration may result. Also, overfilling the battery will reduce the life of the battery.

8. Replace the filler caps on all batteries.

Replacing Used Batteries

When the vehicle begins to show a loss of range or when the length of the discharge/charge cycle is significantly reduced, the batteries are probably getting old and losing their ability to hold a charge. Take the vehicle to an Authorized Service Dealer and have them test the batteries to determine whether the batteries need to be replaced. The Dealer can then replace the batteries for you. If you wish to replace the batteries yourself, use the following procedure:

1. Raise the cargo bed, turn the key off, and remove it.
2. Disconnect the long, black, main negative lead running from the bank of batteries to the vehicle from the battery post (Fig. 32).

Warning

Incorrect battery cable routing could damage the vehicle and cables causing sparks. Sparks can cause the battery gasses to explode, resulting in personal injury.

- Always ensure the battery polarity when making connections.

Caution

Batteries can give you a powerful electrical shock.

- Use tools with plastic handles or wrap the handles of metal tools with electrical tape.
- Be careful not to contact both a positive terminal and a negative terminal at the same time.

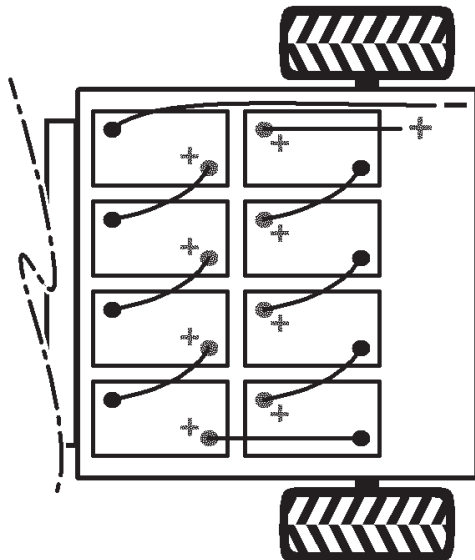

Figure 32

3. Remove the long, red, main positive lead running from the bank of batteries to the vehicle from the battery post (Fig. 32).
4. Disconnect all of the battery leads from the batteries.
5. Remove the battery retainers located between the batteries.

6. Remove all of the batteries and recycle them according to your local codes.
7. Install new batteries in the places vacated by the old batteries.

Note: Pay attention to the battery polarity when installing the new batteries (Fig. 32).
8. Install the battery retainers and torque the nuts to 150 to 200 in-lb (17 to 22 N·m).
9. Connect the batteries together with the battery cables removed previously, as illustrated in Figure 32.
10. Connect the long, red, main positive lead between the bank of batteries and the vehicle (Fig. 32).
11. Connect the long, black, main negative lead between the bank of batteries and the vehicle (Fig. 32).
12. Torque the nuts securing all battery cables to 120 to 180 inch-lb (13.5 to 21 N·m).
13. Coat the battery terminals with Toro battery terminal protector.
14. Ensure that the rubber boots on each battery cable are securely seated over the battery terminals.

Storing the Batteries

Charge the batteries fully before placing the vehicle into storage. Plug the charger into a wall outlet while the vehicle and batteries are in storage. Leave the charger plugged into a wall outlet and charging receptacle during storage to ensure that the batteries stay charged and do not freeze; otherwise, charge the batteries at least once every 3 months.

Greasing the Vehicle

Lubricate all bearings and bushings after every 100 hours or once a year, whichever occurs first. Grease them more frequently when using the vehicle for heavy-duty operations.

Grease Type: No. 2 General Purpose Lithium Base Grease

Where to Add Grease

The grease fitting locations are at the four tie rod ends (Fig. 33) and the two king pins (Fig. 34).

1. Wipe the grease fitting clean so that foreign matter cannot be forced into the bearing or bushing.
2. Pump grease into the bearing or bushing.

3. Wipe off excess grease.

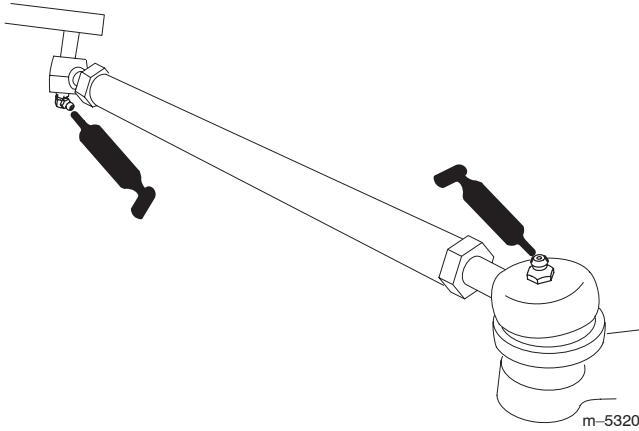

Figure 33

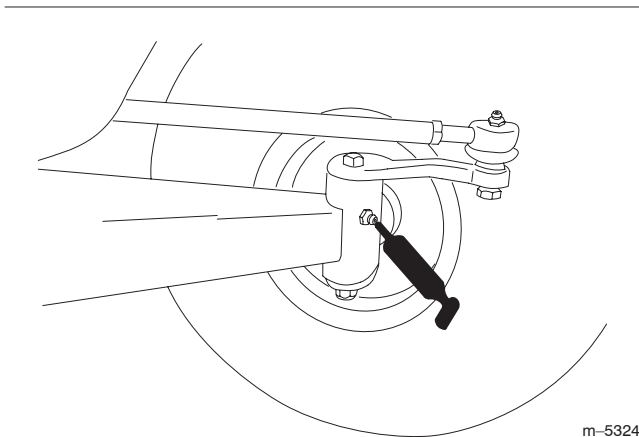

Figure 34

Servicing the Brakes

Inspecting the Brakes

Brakes are a critical safety component of the vehicle. As with all safety components, they should be closely inspected at regular intervals to ensure optimum performance and safety. The following inspections should be done every 100 hours:

- Inspect the brake shoes for wear or damage. If the lining (brake pad) thickness is less than 1/16 inch (1.6 mm), the brake shoes should be replaced.
- Inspect the backing plate and other components for signs of excessive wear or deformation. If any deformation is found, the appropriate components must be replaced.

Adjusting the Brake Pedal

Adjust the brake if the parking brake does not hold, the brake pedal travel is excessive, or braking power is not sufficient when the brake pedal is depressed. Check the adjustment every 200 hours.

1. Turn the ignition off and remove the key.
2. Check the brake cables at the brake equalizer (located under the dash) and determine approximately how far up the brake rod the equalizer needs to travel so that there is no slack in the cables (Fig. 35).

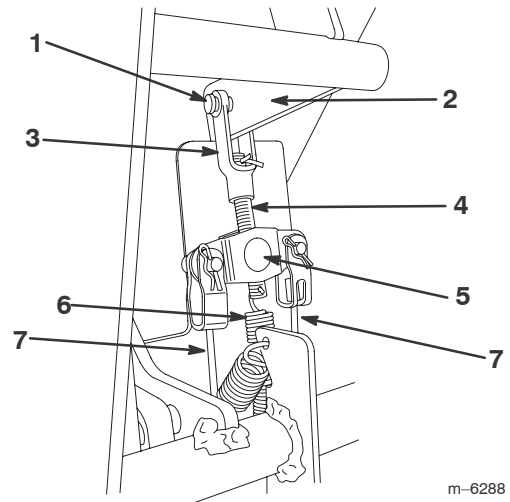

Figure 35

- | | |
|---------------------|--------------------|
| 1. Clevis pin | 5. Brake equalizer |
| 2. Brake lever | 6. Spring |
| 3. Brake rod clevis | 7. Brake cable |
| 4. Brake rod | |

3. Remove the hairpin cotter and clevis pins securing the brake rod clevis (Fig. 35).
4. Disconnect the spring from the end of the brake rod (Fig. 35).
5. Press the brake pedal down fully to raise the brake lever.
6. Thread the brake rod in or out of the brake equalizer as needed to remove the slack from the brake cables (Fig. 35). Do not overtighten the cables.
7. Install the spring into the hole in the brake rod (Fig. 35).
8. Connect the clevis on the brake rod to the brake lever using the clevis pin and hairpin cotter removed previously (Fig. 35).
9. Ensure that there is some free play in the brake pedal before the brake engages. If not, repeat this procedure until there is.

Inspecting the Tires

Check the tire condition at least every 100 hours of operation. Operating accidents, such as hitting curbs, can damage a tire or rim and also disrupt wheel alignment, so inspect tire condition after an accident.

Check the wheels to ensure that they are mounted securely. Torque the center bolts on the front wheels to 135–165 ft-lb (183–224 N·m) and the front and rear lug nuts to 45–65 ft-lb (61–88 N·m).

Adjusting the Front Suspension

The ride height of each side of the vehicle can be adjusted separately. The ride height should be 8-3/4 to 9-1/2 inch (22.2–24.1 cm) with the following parameters:

- The tire pressure should be at 12 psi (83 kPa).
- The vehicle should be driven back and forth a few times to relax the A-arms.
- Measure the ride height with the wheels facing straight ahead and a 175–225 lb (79–102 kg) operator in the driver's seat.

Note: The driver should drive up to the measurement area and stay seated in the vehicle while the measurement is being taken.

- Measure the ride height on a flat surface, from the bottom of the front tongue to the ground.
1. Jack the front end of the vehicle off of the ground; refer to Jacking the Vehicle, page 27.
 2. Remove the travel limiting bolt (Fig. 36).
 3. Loosen the centering bolts in the front A-arm (Fig. 36).
 4. Remove the ride height adjustment bolt (Fig. 36).

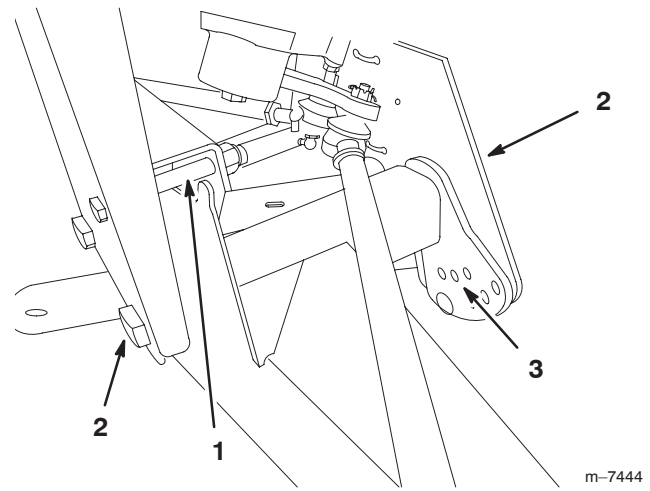

Figure 36

1. Travel limiting bolt
2. Centering bolt
3. Ride height adjustment bolt

5. Rotate the front A-arm to the desired position (refer to the note below) and replace the ride height adjustment bolt (Fig. 36).

Note: The A-arms are made with rubber and have different spring rates. Because of the different spring rates, the A-arms come adjusted from the factory based on that spring rate. Generally the adjustment bolts will be installed in hole number 2, 3, or 4 (Fig. 37) and it may be different from the left side (driver side) to the right side (passenger side). If the A-arms look like they are sagging, then they should be adjusted to the next higher number (Fig. 37). Each hole equals about 3/4 inch (19 mm) of adjustment at the wheel. You will also need to do this if you are adding heavy attachments or carrying heavy loads often.

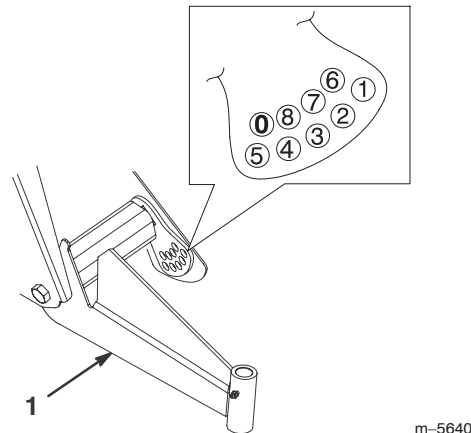

Figure 37

1. Left-hand A-arm

6. Torque the ride height adjustment bolt to 135–165 ft-lb (183–224 N·m).
7. Replace the travel limiting bolt (Fig. 36).

Note: The vehicle may need to be lowered to the ground on that side to install the bolt.

8. Tighten and torque the centering bolts to 240–290 ft-lb (325–393 N·m).
9. Check the ride height at the front tongue per the dimensions and parameters given at the beginning of this procedure.

Adjusting the Front Wheel Toe-In

Check the front wheel toe-in after every 100 operating hours, or annually, whichever occurs first.

The toe-in should be 1/8–5/8 inch (3–16 mm) with the following parameters:

- The tire pressure should be at 12 psi (83 kPa).
- The ride height should be correct before setting the toe-in; refer to Adjusting the Front Suspension, page 32.
- The vehicle should be driven back and forth a few times to relax the A-arms.
- Measure the toe-in with the wheels facing straight ahead and a 175–225 lb (79–102 kg) operator in the driver’s seat.

Note: The driver should drive up to the measurement area and stay seated in the vehicle while the measurement is being taken.

If the vehicle will be run with medium to heavy loads most of the time, set the toe-in on the high side of the recommended amount. If it is going to be run with a light load most of the time, set the toe-in on the low side of the recommended amount.

1. Ensure that the front suspension is adjusted properly; refer to Adjusting the Front Suspension, page 32. Adjust if necessary.
2. Measure the distance between both of the front tires at the axle height at both the front and rear of the front tires (Fig. 38). A fixture or alignment gauge is needed for the rear measurement of the front tires at axle

height. Use the same fixture or alignment gauge to accurately measure the front of the front tires at axle height (Fig. 38).

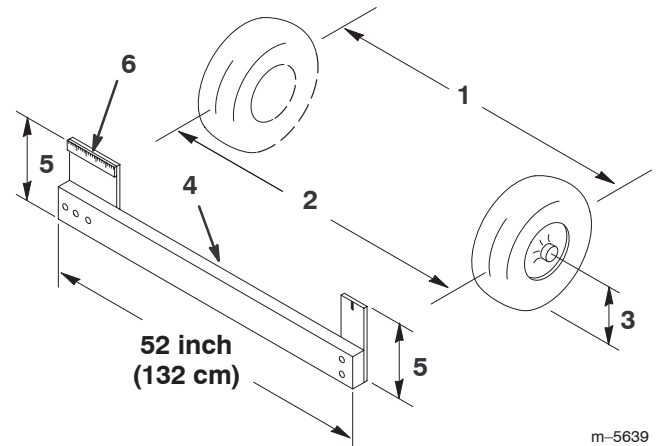

Figure 38

- | | |
|---------------------------|------------------------------|
| 1. Tire center line—back | 4. Fixture |
| 2. Tire center line—front | 5. Axle center line distance |
| 3. Axle center line | 6. 6 inch (15 cm) ruler |

3. If the measurement does not fall within the specified range (refer to the dimensions and parameters at the beginning of this procedure), loosen the jam nuts at both ends of the tie rods (Fig. 39).
4. Rotate both tie rods to move the front of the tire inward or outward.

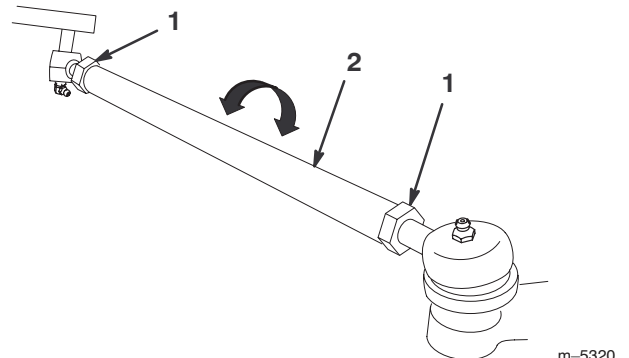

Figure 39

- | | |
|------------|------------|
| 1. Jam nut | 2. Tie rod |
|------------|------------|

5. Tighten the tie rod jam nuts when the adjustment is correct.
6. Ensure that there is full travel of the steering wheel in both directions.

Checking the Transaxle Oil Level

Check the oil level in the transaxle at the rear of the vehicle every 100 operating hours.

1. Park the vehicle on a level surface, set the parking brake, and turn off and remove the key.
2. Remove the check bolt on the transaxle (Fig. 40).

The oil level should be even with the bottom of the check hole.

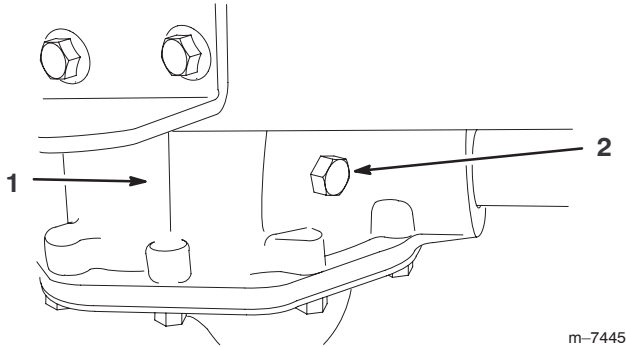

Figure 40

1. Transaxle
2. Check bolt

3. If the oil level is low, add 10w30 motor oil to the check hole until it runs out the hole.
4. Replace the check bolt and torque it to 15 to 20 ft-lb (20 to 27 N·m).

Replacing the Fuses

There are 2 fuses in the electrical system. They are located beneath the steering column (Fig. 41).

Vehicle	10 amp
Accessories	10 amp

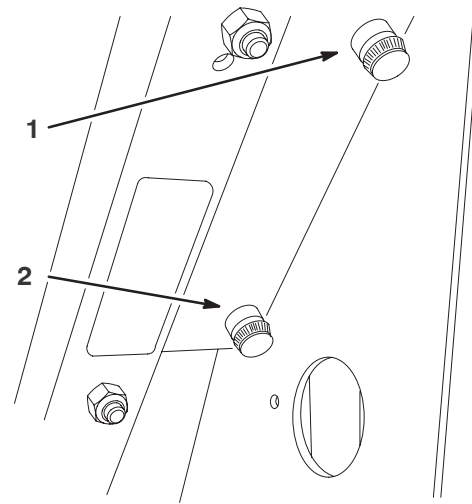

Figure 41

1. Vehicle Fuse
2. Accessories Fuse

Replacing the Headlights

Specification: Toro #104-7312, 28 volt

Note: The headlights are wired in series; therefore, when one headlight burns out, neither will illuminate. If possible, change both headlights at the same time.

1. Set the parking brake, turn the vehicle off, and remove the key.
2. Reach beneath the dash and push the headlight out of the hood.
3. Remove the screws attaching the wire harness to the headlight.
4. Remove the rubber seal from around the headlight (Fig. 42). Discard the headlight.
5. Align the notch on the inside of the seal with the notch on the new headlight (Fig. 42). Slide the seal onto the headlight until the seal is firmly in place.

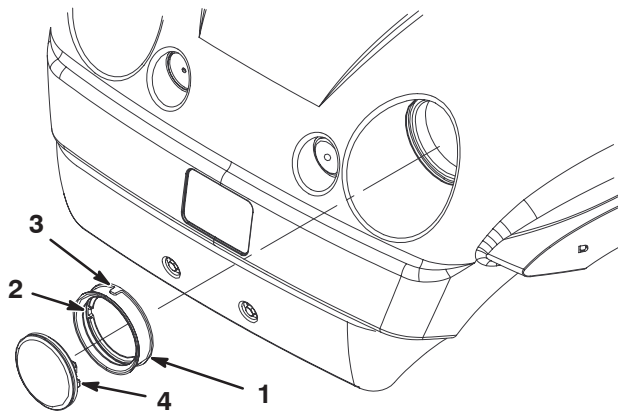

Figure 42

- | | |
|---|---|
| 1. Rubber seal | 3. Outside notch—align with notch in hood |
| 2. Inside notch—align with notch on headlight | 4. Headlight |

-
6. Attach the headlight to the wire harness using the previously removed screws.
 7. Align the notch on the outside of the seal with the notch in the hood. Push the headlight and seal into the hood until it is firmly in place.

Note: Applying soapy water to the outside of the seal may aid in sliding the seal into the hood.

Washing the Vehicle

The vehicle should be washed as needed. Use water alone or with a mild detergent. A rag may be used, however the hood will lose some of its luster.

Important Do not use high pressure water when washing the vehicle. It may damage the electrical system, loosen important decals, or wash away necessary grease at friction points. Avoid excessive use of water, especially near the control panel, motor, and batteries.

Troubleshooting

The vehicle contains a computer that monitors the state of the vehicle electrical systems. This computer communicates the status of the vehicle to you through the vehicle status light. When the vehicle is functioning properly, the light will be on. When there is a problem, the light flashes. The number of flashes changes depending on the problem. The following table lists the various flash patterns, the cause, and the steps you can take to resolve the problem.

Status Light Flash Pattern	Cause	Corrective Action
Always on	The system is functioning properly.	None
1 flash	The computer programming personality is out of range.	Turn the On/Off key to the Off position, wait a few seconds, and turn the On/Off key to the On position. If the condition continues, refer to your Authorized Service Dealer.
2 flashes	The accelerator pedal was pressed when the On/Off key was turned.	Turn the On/Off key to the Off position, release the accelerator pedal, and turn the On/Off key to the On position.
3 flashes	The power block has a short circuit (MOSFET S/C).	Turn the On/Off key to the Off position, wait a few seconds, and turn the On/Off key to the On position. Check all batteries and high current controller connections. If the condition continues, refer to your Authorized Service Dealer.
	A poor batter or power cable connection.	
4 flashes	The line contactor is not responding to commands.	Turn the On/Off key to the Off position, wait a few seconds, and turn the On/Off key to the On position. If the condition continues, refer to your Authorized Service Dealer.
5 flashes	The charger interlock switch is active.	Turn the On/Off key to the Off position, disconnect the charger, and turn the On/Off key to the On position.
6 flashes	Accelerator POT is out of adjustment.	Refer to your Authorized Service Dealer.
7 flashes	Battery voltage is out of range.	Refer to your Authorized Service Dealer to have the batteries tested and replaced if necessary.
8 flashes	The controller is overheated.	The vehicle will continue to run, but at reduced power until the controller cools down.
9 flashes	The motor is over heated or the battery is nearly discharged (the vehicle will go into the energy saving mode).	If the batter meter displays more than one bar, stop the vehicle and allow the motor to cool before operating it again. If the battery meter displays only one bar, charge the vehicle immediately.
Off	The controller has failed.	Refer to your Authorized Service Dealer.

