



Z449 Z Master[®]

With 52in TURBO FORCE Side Discharge Mower

Model No. 74415 - 250000001 and up.

Parts Catalog

Ordering Replacement Parts

To order replacement parts, please supply the part number, the quantity, and the description of each part desired.

Understanding Reference Numbers

Each Identified part in an illustration has a reference number. The reference number for a part also appears in the parts list, along with other information about the part.

This catalog uses two special reference number formats, one to indicate parts in a service assembly and another to indicate the quantity of a given part in an illustration.

Service Assembly Reference Numbers

Parts in service assemblies have reference numbers in the form a:b. The a represents the reference number of the entire service assembly and the b represents a sequential number unique to each part within the service assembly.

For example, a wheel assembly might be identified by reference number 6, the tire by 6:1, the valve by 6:2, and the wheel by 6:3. When you order the assembly identified by reference number 6, you receive all parts identified by reference numbers 6:1, 6:2, and 6:3. However, you may also order any part individually. Reference numbers of this type appear in illustrations and in part lists.

Reference Numbers Indicating Quantity

In an illustration, if a reference number indicates more than one part, the reference number has the form nX y. The n represents the quantity of the part, the X is the multiplication symbol, and the y represents the reference number.

For example, in an illustration, the reference number 2X 37 means that two of the parts identified by reference number 37 are indicated.

Contents

Description	Page	Description	Page
Front Frame Assembly 3	Roll-Over-Protection-System Assembly No. 107-8093 26
Caster Wheel Assembly No. 1-634662 4	Fuel Tank/Fuel Valve Assembly Kawasaki FH580V AS30 27
Height of Cut Assembly 5	Cylinder/Crankcase Assembly Kawasaki FH580V AS30 28
Main Frame Assembly 6	Piston/Crankshaft Assembly Kawasaki FH580V AS30 30
Fuel System Assembly 7	Valve/Camshaft Assembly Kawasaki FH580V AS30 32
Parking Brake Assembly 8	Lubrication Equipment Assembly Kawasaki FH580V AS30 34
Motion Control Assembly 9	Cooling Equipment Assembly Kawasaki FH580V AS30 36
Hydraulic System Assembly 10	Electric Equipment Assembly Kawasaki FH580V AS30 38
Hydraulic Pump Assembly No. 103-1942 12	Control Equipment Assembly Kawasaki FH580V AS30 40
Pump Idler and Belt Assembly 13	Carburetor Assembly Kawasaki FH580V AS30 42
Engine, Clutch and Muffler Assembly 14	Air-Filter/Muffler Assembly Kawasaki FH580V AS30 44
Deck Connection Assembly 15	Starter Assembly Kawasaki FH580V AS30 46
Deck Assembly No. 107-1670 16	Label Assembly Kawasaki FH580V AS30 48
Idler Assembly 18		
Spindle Assembly No. 107-8504 19		
Deck Decal Assembly No. 107-1669 20		
Rubber Deflector Assembly No. 108-4060 21		
Electrical System Assembly 22		
Seat and Bracket Assembly 23		
Seat Assembly No. 107-1867 24		
Roll-Over-Protection-System Assembly 25		

Part Description Abbreviations

Part descriptions in this catalog may include the following abbreviations.

AR. as required	INC. incorporated
ASM. assembly	LH. left hand
CARR. carriage	NI. nylon insert
DEG. degrees	PPH. phillips pan head
FH. flat head	PTH. phillips truss head
GA. gauge	PTO. power take off
HF. hex flange	RH. right hand
HH. hex head	SFH. slotted fillister head
HHF. hex head flange	SHH. slotted hex head
HHFTF. hex head flange thread forming	SHWH. slotted hex washer head
HJ. hex jam	SPH. slotted pan head
HLH. hex lag head	SQH. square head
HOC. height-of-cut	SRH. slotted round head
HS. hex	STD. standard
HSBH. hex socket button head	TAP. self tapping
HSFH. hex socket flat head	TTH. torx truss head
HSH. hex socket head	WH. wing head
HWH. hex washer head	
HWHTF. hex washer head thread forming	
HYD. hydraulic	

Footnotes

- ❶ Not illustrated
- ❷ Not serviced separately
- ❸ Obtain parts from your local Kawasaki dealer

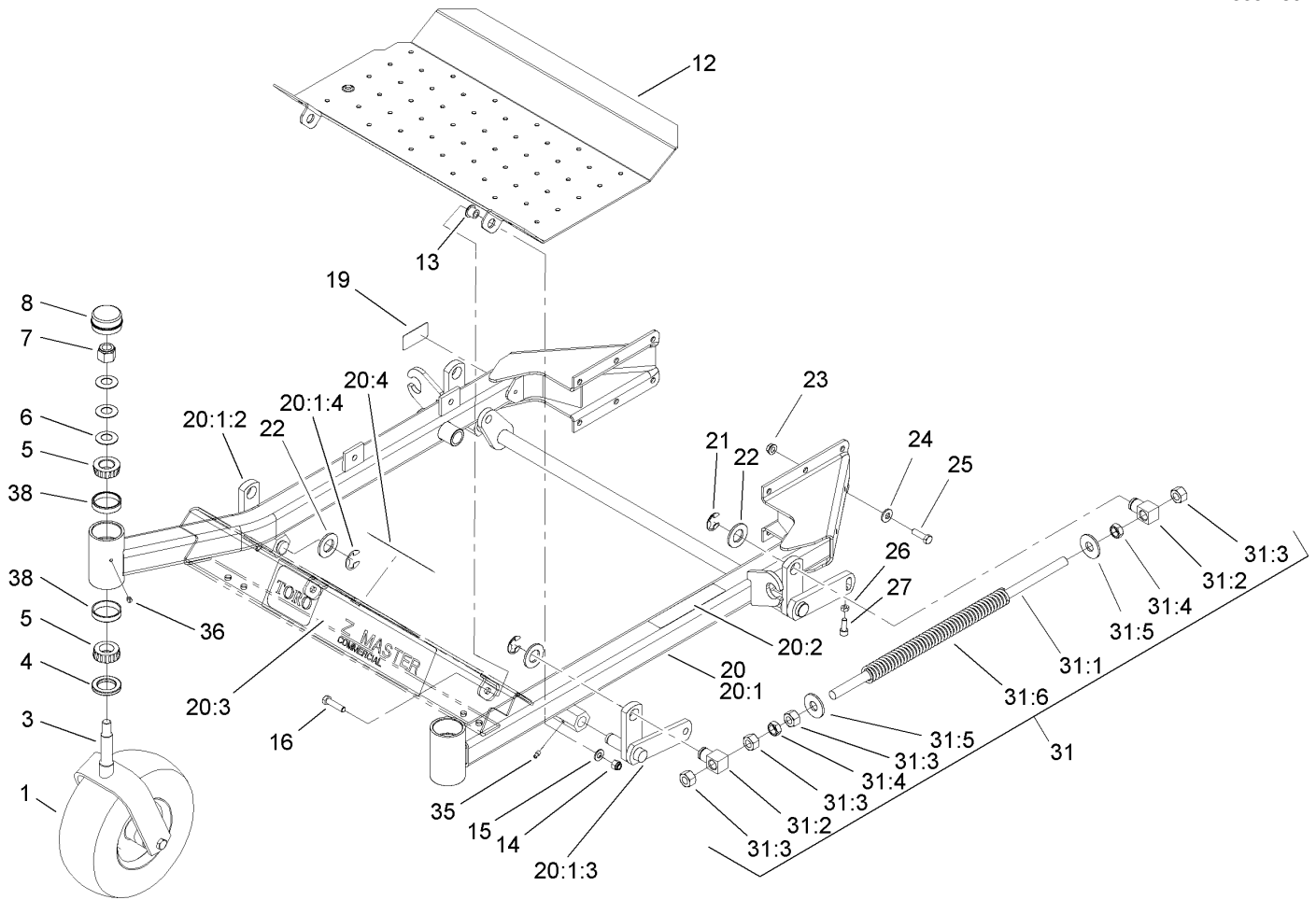

Front Frame Assembly

Ref	Part No.	Qty.	Description
1	1-634662	2	Caster Wheel ASM
3	1-632511-01	2	Caster
4	1-543511	2	Seal-Grease
5	254-94	4	Bearing-Cone, Tapered
6	1-633508	6	Washer-Bellville
7	3296-51	2	Nut-Lock, NI
8	1-543513	2	Cap-Grease
12	108-5007-03	1	Floor Pan
13	86-2180	2	Bushing-Flange
14	3296-39	2	Nut-Lock, NI
15	3256-24	2	Washer-Flat
16	323-8	2	Screw-HH
19	105-2625	1	Decal-Std, Safety
20	107-1650	1	Front Frame ASM
20:1		1	Frame-Front
20:1:2	99-3872-01	1	RH Lift Arm ASM
20:1:3	99-3871-01	1	LH Lift Arm ASM
20:1:4	32151-103	2	Ring-Snap
20:2	1-633818	1	Decal-Warning
20:3	106-7451	1	Decal
20:4	107-2112	1	Decal-Warning
21	32151-103	4	Ring-Snap
22	3256-29	6	Washer-Flat
23	3290-357	12	Nut-HHF

Ref	Part No.	Qty.	Description
24	98-5975	12	Washer-Belleville
25	323-7	12	Screw-HH
26	3218-2	2	Nut-Jam
27	3274-18	2	Screw-HSH
31	1-634439	2	Front Frame Spring ASM
31:1	1-633096	1	Rod-Lift, Deck
31:2	1-633441	2	Swivel-Deck Mount, Rear
31:3	3217-11	4	Nut-Hex
31:4	3218-6	2	Nut-Jam
31:5	3256-7	2	Washer-Flat
31:6	1-633064	1	Spring-Support, Deck
35	302-19	4	Fitting-Grease
36	1-811010	2	Plug
38	254-72	4	Bearing-Cup, Tapered

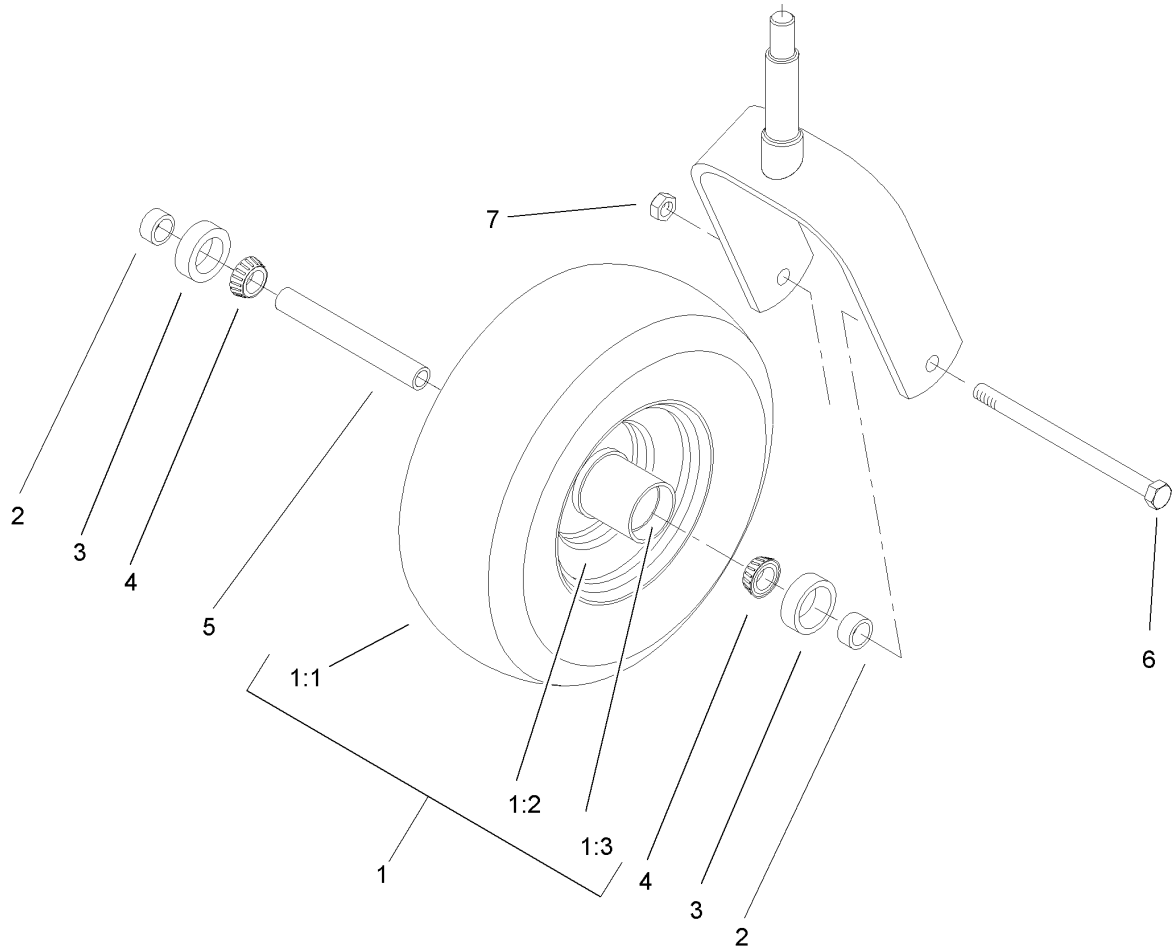

Caster Wheel Assembly No. 1-634662

Ref	Part No.	Qty.	Description	
1	1-633582	1	Wheel And Tire ASM	
1:1	1-633002	1	Tire	
1:2	1-633583	1	Wheel	
1:3	1-633584	2	Bearing-Cup	
2	1-633581	2	Spacer-Bearing	
3	1-633580	2	Seal-Bearing	
4	1-633585	2	Bearing-Cone, Taper	
5	1-633579	1	Spacer-Caster, Front	
6	325-36	1	Screw-HH	
7	3296-45	1	Nut-Lock, NI	

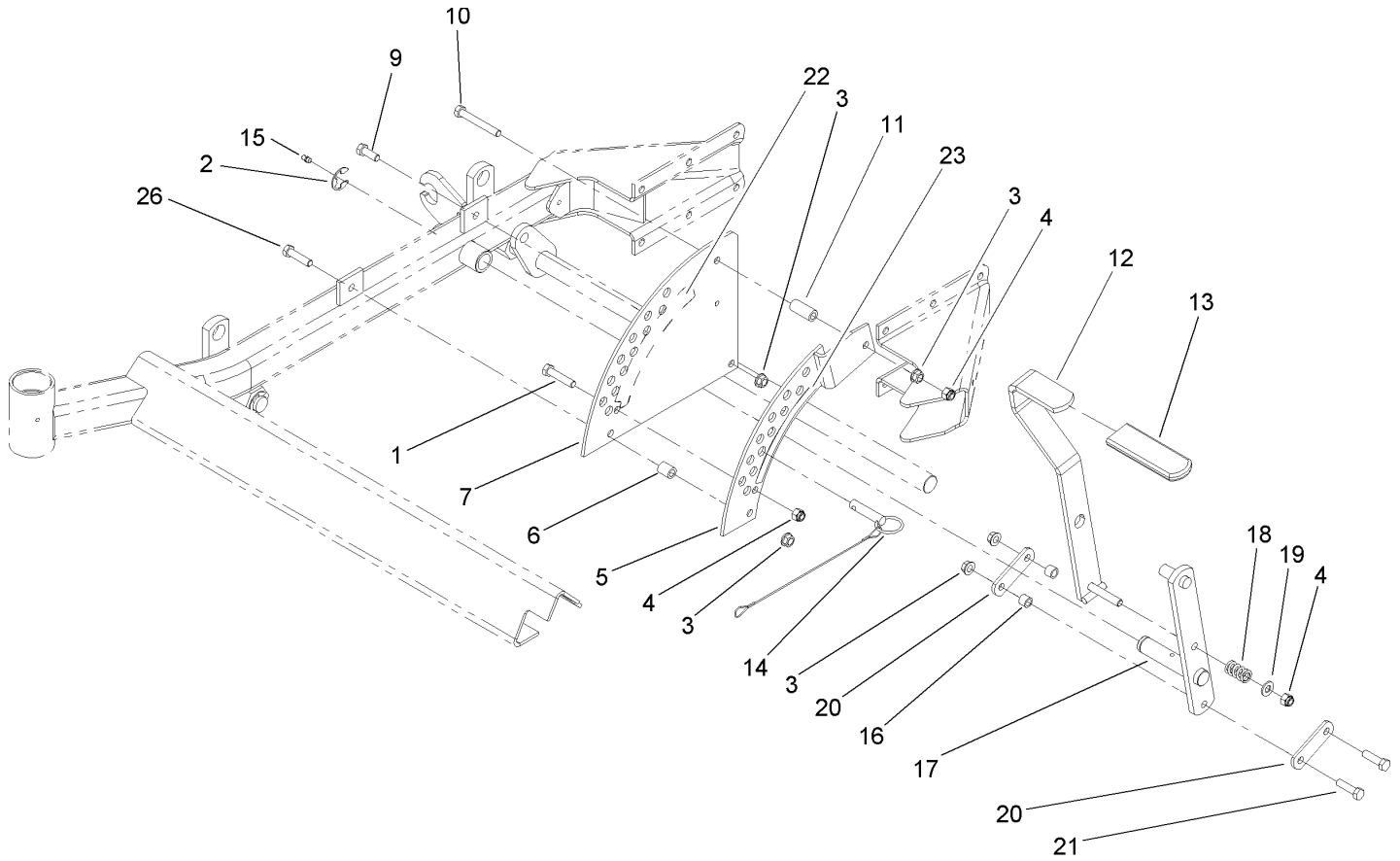

Height of Cut Assembly

Ref	Part No.	Qty.	Description
1	323-9	1	Screw-HH
2	32151-103	1	Ring-Snap
3	3290-357	5	Nut-HHF
4	3296-39	3	Nut-Lock, NI
5	1-652235-01	1	Plate-Lift, Deck
6	1-633080	1	Bushing-Lever, Lift
7	1-653230-01	1	Plate-Lift, Deck
9	323-6	1	Screw-HH
10	323-13	1	Screw-HH
11	1-633082	1	Bushing-Lever, Lift
12	103-2078-03	1	Handle-Lift
13	1-633295	1	Grip-Lever, Lift
14	106-9951	1	Hitch Pin ASM
15	302-19	1	Fitting-Grease
16	103-1918	2	Bushing
17	106-6598-03	1	Lift Arm ASM
18	1-633325	1	Spring-Compression
19	3256-24	1	Washer-Flat
20	1-633068	2	Arm-Lift, Deck
21	323-29	2	Screw-HH
22	108-1051	1	Decal-Deck Height, Outer
23	108-1050	1	Decal-Deck Height, Inner
26	323-8	1	Screw-HH

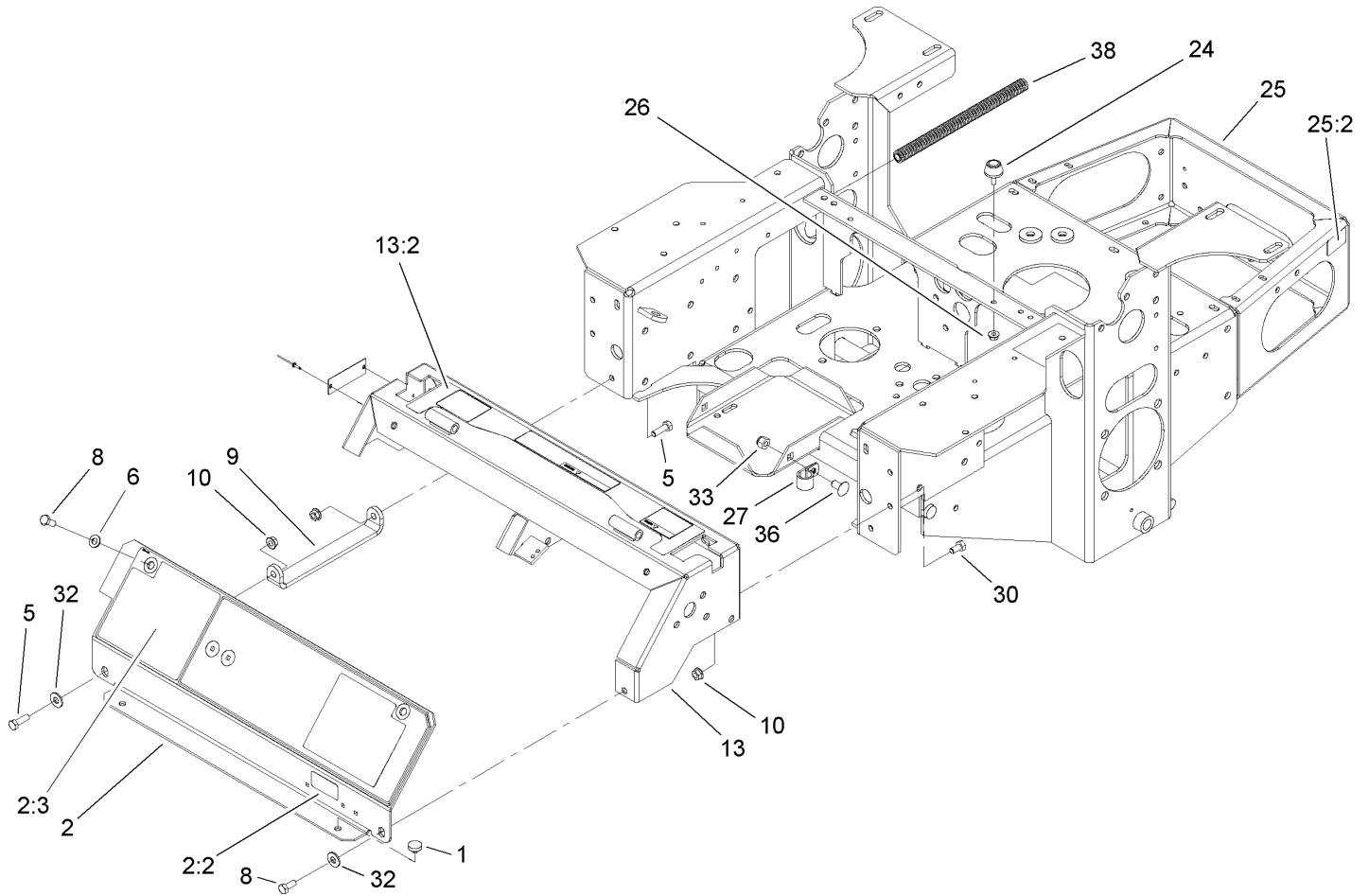

Main Frame Assembly

Ref	Part No.	Qty.	Description
1	1-513658	2	Bumper
2	108-1864	1	Panel ASM
2:2	98-4387	1	Decal-Protection, Ear
2:3	107-8445	1	Decal-Cover, Panel
5	322-5	2	Screw-HH
6	3256-23	2	Washer-Flat
8	322-3	3	Screw-HH
9	1-653089-03	1	Bracket
10	32128-20	6	Nut-HF
13	108-5997	1	Console Asm, Z400 (W/ Decals)
13:2	108-5995	1	Decal, Top Console Z400
24	1-523420	2	Bumper
25	108-2783	1	Main Frame ASM
25:2	65-2690	2	Decal-Surface, Hot
26	32128-33	2	Nut-HF
27	1-633396	1	Clip-Loom
30	322-2	4	Screw-HH
32	3256-3	2	Washer-Flat
33	3296-39	1	Nut-Lock, NI
36	3231-21	1	Screw-CARR
38	24-7922	2	Cover-Shaft, Drive

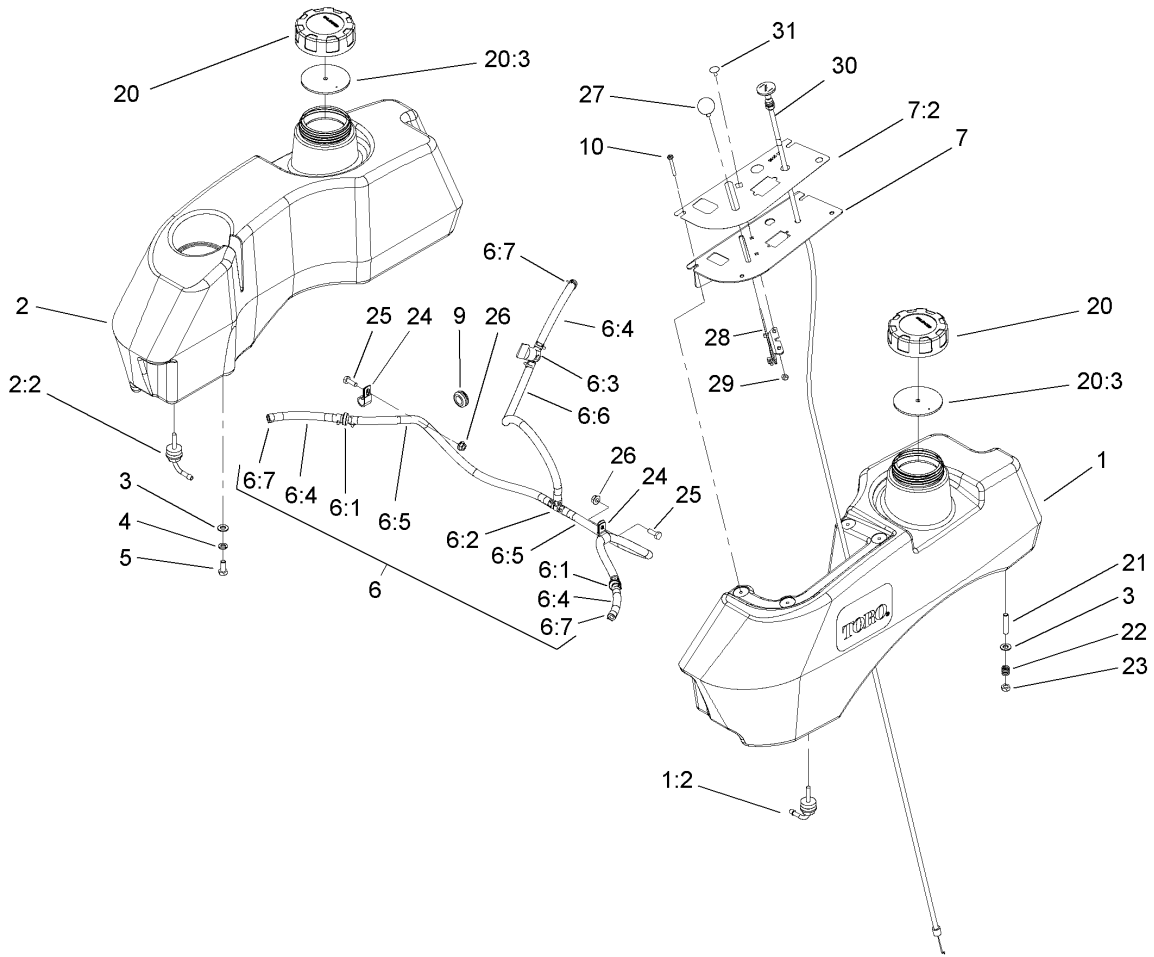

Fuel System Assembly

Ref	Part No.	Qty.	Description
1	107-2146	1	LH Fuel Tank ASM
1:2	103-2605	1	Fitting-Fuel, Bulkhead
2	106-9975	1	RH Fuel Tank ASM
2:2	103-2605	1	Fitting-Fuel, Bulkhead
3	3256-23	8	Washer-Flat
4	1-805005	4	Washer-Lock
5	322-3	4	Screw-HH
6		1	Fuel Line ASM
6:1	99-5000	2	Valve-Check, Fuel
6:2	99-5005	1	Fitting-Tee, Barbed
6:3	1-603770	1	Valve-Fuel
6:4	99-7190	3	Hose-Fuel
6:5	99-3185	2	Hose-Fuel
6:6	106-8720	1	Hose-Fuel
6:7	1-303077	12	Clamp
7	107-2149	1	Control Panel ASM
7:2	107-2148	1	Decal-Panel, Control
9	1-543296	2	Grommet
10	32122-30	4	Screw-Pth
20	88-3980	2	Gas Cap ASM
20:3	88-4010	1	Gasket-Cap, Gas
21	1-633023	4	Stud
22	1-633349	4	Spring-Tank, Fuel
23	3296-47	4	Nut-Lock, NI

Ref	Part No.	Qty.	Description
24	1-513762	2	Clip-Loom
25	321-4	2	Screw-HH
26	32128-33	2	Nut-HF
27	1-513592	1	Knob-Ball
28	1-633696	1	Throttle Cable ASM
29	3296-2	2	Nut-Lock
30	1-603336	1	Control-Choke
31	1-807513	2	Bolt-CARR

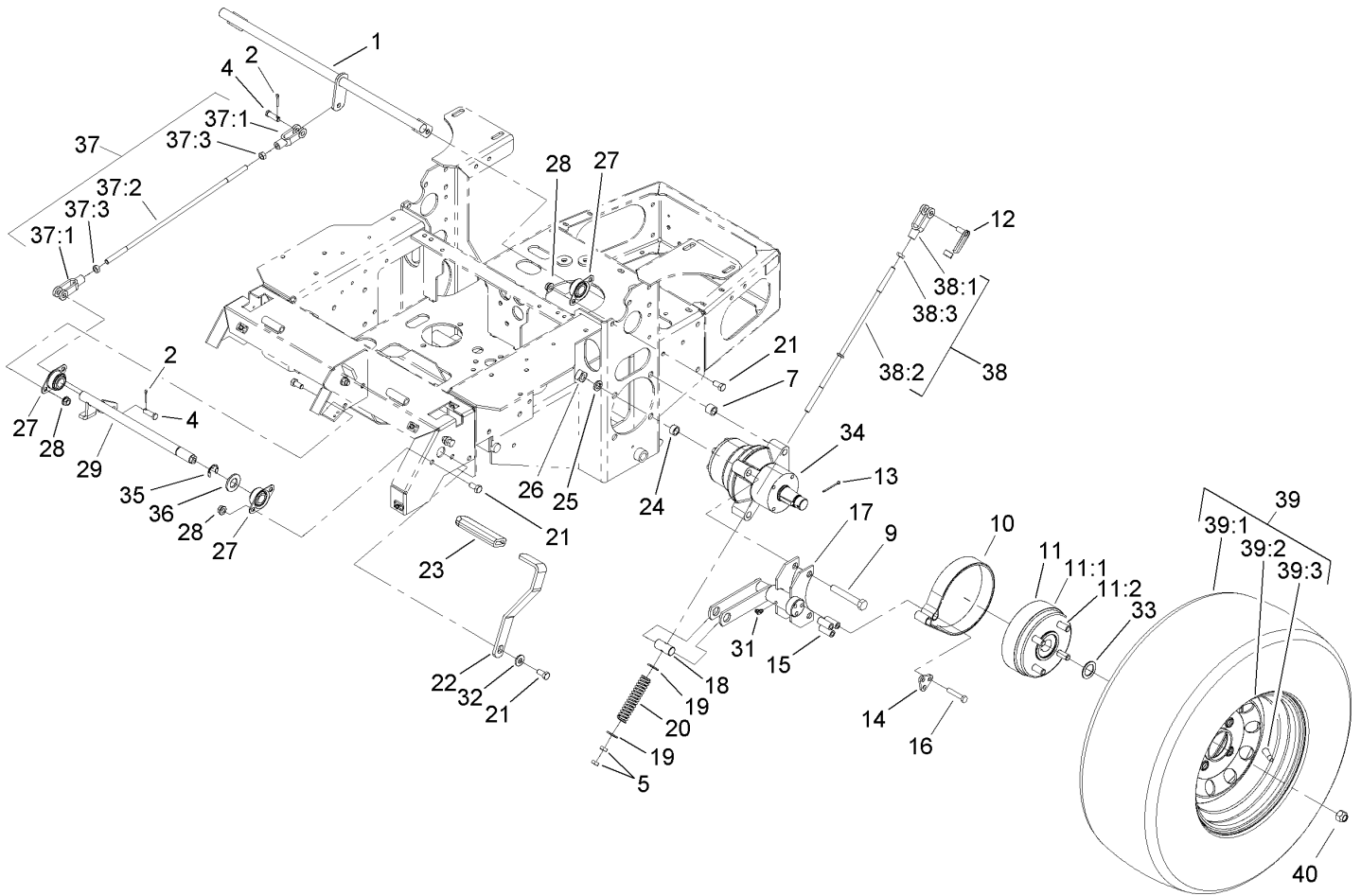

Parking Brake Assembly

Ref	Part No.	Qty.	Description
1	1-652073-03	1	Crank-Brake, Park
2	3272-10	2	Pin-Cotter
4	1-808285	2	Pin-Clevis
5	3219-3	4	Nut-Hex
7	1-653068	4	Spacer-Wheel
9	325-13	8	Screw-HH
10	103-0355	2	Band-Brake
11	103-0590	2	Hub And Wheel ASM
11:1	103-0589	1	Wheel Hub ASM
11:2	1-633926	4	Stud-Wheel
12	103-2399	2	Pin-Spring, Clevis
13	1-806800	2	Pin-Cotter
14	103-0374	2	Retainer-Band, Brake
15	103-0384	6	Spacer
16	322-9	6	Screw-HH
17	103-0352-03	2	Bracket-Brake
18	1-633144	2	Pin-Trunion
19	3256-4	4	Washer-Flat
20	1-633454	2	Spring-Brake
21	323-4	9	Screw-HH
22	1-653074-03	1	Handle-Brake, Park
23	1-633268	1	Grip-Lever, Brake
24	1-653069	4	Spacer-Wheel
25	3253-7	8	Washer-Lock

Ref	Part No.	Qty.	Description
26	103-0131	8	Nut-Square
27	1-633102	4	Bearing-Flange, Side
28	3290-357	8	Nut-HHF
29	103-3116	1	Shaft-Brake, Parking
31	1481	2	Fitting-Grease
32	98-5975	1	Washer-Belleville
33	1-523157	2	Washer-Spacer
34	103-5333	2	Motor-Wheel
35	32151-48	1	E-Ring
36	3256-28	1	Washer-Flat
37	103-4328	1	Brake Rod ASM
37:1	1-633131	2	Yoke-Linkage, Brake
37:2	1-653061	1	Linkage-Handle, Brake
37:3	3219-3	2	Nut-Hex
38	103-4329	2	Brake Rod ASM
38:1	1-633131	1	Yoke-Linkage, Brake
38:2	103-0356	1	Rod-Brake
38:3	3219-3	1	Nut-Hex
39	1-653159	2	Wheel And Tire ASM
39:1	1-653160	1	Tire
39:2	1-653161	1	Wheel
39:3	232-27	1	Stem-Valve
40	242-50	8	Nut-Lug

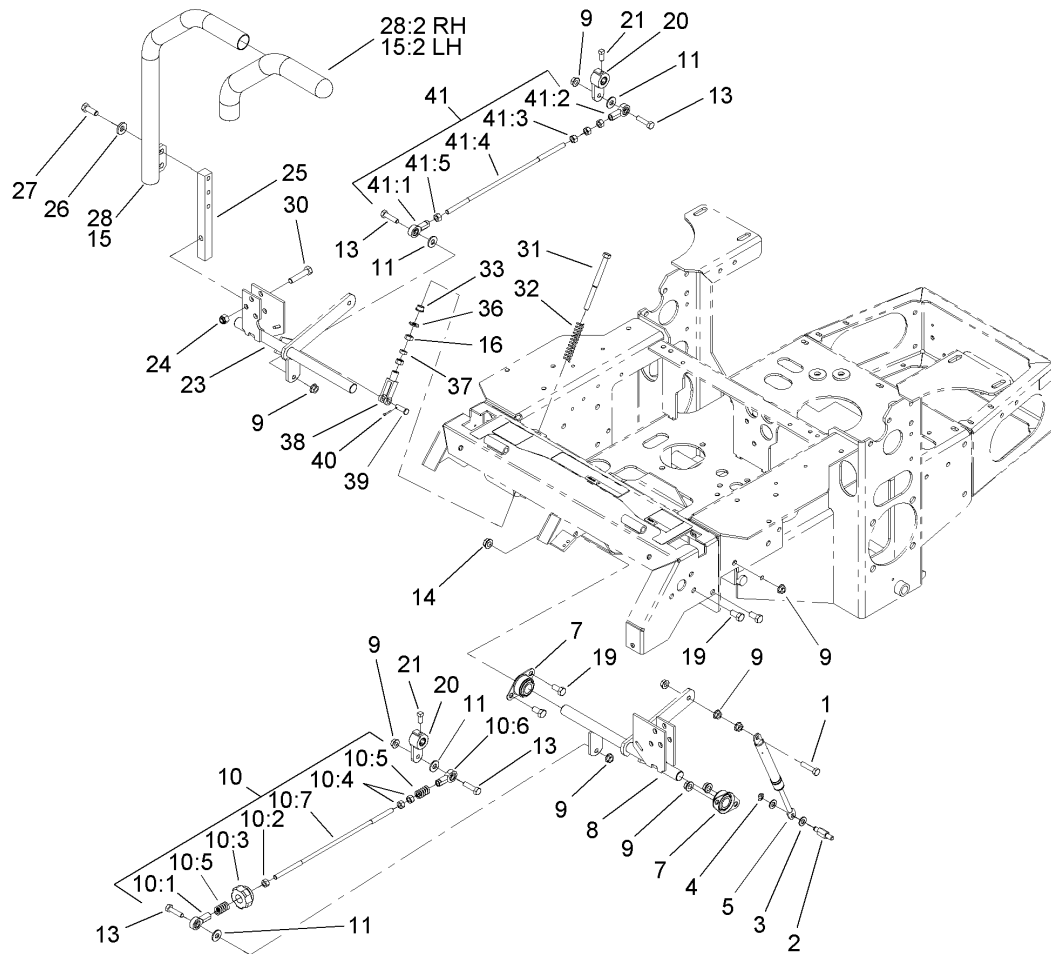

Motion Control Assembly

Ref	Part No.	Qty.	Description
1	1-403180	2	Screw-HH
2	103-4101	2	Pin-Damper
3	3256-23	4	Washer-Flat
4	32120-35	2	E-Ring
5	103-4079	2	Damper-Control, Motion
7	1-633102	4	Bearing-Flange, Side
8	103-4774	1	Control-Motion, LH
9	32128-20	12	Nut-HF
10	103-4326	1	Tracking Rod ASM
10:1	1-543017	1	Balljoint-RH
10:2	3219-2	1	Nut-Hex
10:3	103-3060	1	Knob-Tracking
10:4	1-804524	2	Nut
10:5	1-323245	2	Spring-Compression
10:6	1-633152	1	Balljoint-Thread, LH
10:7	103-3066	1	Link-Rod, Tracking
11	3256-3	4	Washer-Flat
13	322-6	4	Screw-HH
14	3290-357	6	Nut-HHF
15	106-9982	1	LH Lever ASM
15:2	106-9987	1	Grip-Control, Motion
16	3219-2	4	Nut-Hex
19	323-4	6	Screw-HH
20	103-3717	2	Arm-Control

Ref	Part No.	Qty.	Description
21	1-803022	2	Screw-Set
23	103-4773	1	Control-Motion, RH
24	3296-39	6	Nut-Lock, NI
25	103-0407	2	Arm-Shaft, Control
26	98-5975	4	Washer-Belleville
27	323-6	4	Screw-HH
28	106-9983	1	RH Lever ASM
28:2	106-9987	1	Grip-Control, Motion
30	323-9	6	Screw-HH
31	1-603737	2	Bolt-Return, Neutral
32	1-603807	2	Spring-Return, Neutral
33	1-603735	2	Bushing-Flanged
36	3256-2	2	Washer-Flat
37	3220-2	2	Nut-Jam
38	1-303105	2	Yoke-Adjustable
39	1-808280	2	Pin-Clevis
40	3272-5	2	Pin-Cotter
41	103-4327	1	Tracking ASM
41:1	1-543017	1	Balljoint-RH
41:2	1-633152	1	Balljoint-Thread, LH
41:3	1-804524	1	Nut
41:4	103-3066	1	Link-Rod, Tracking
41:5	3219-2	3	Nut-Hex

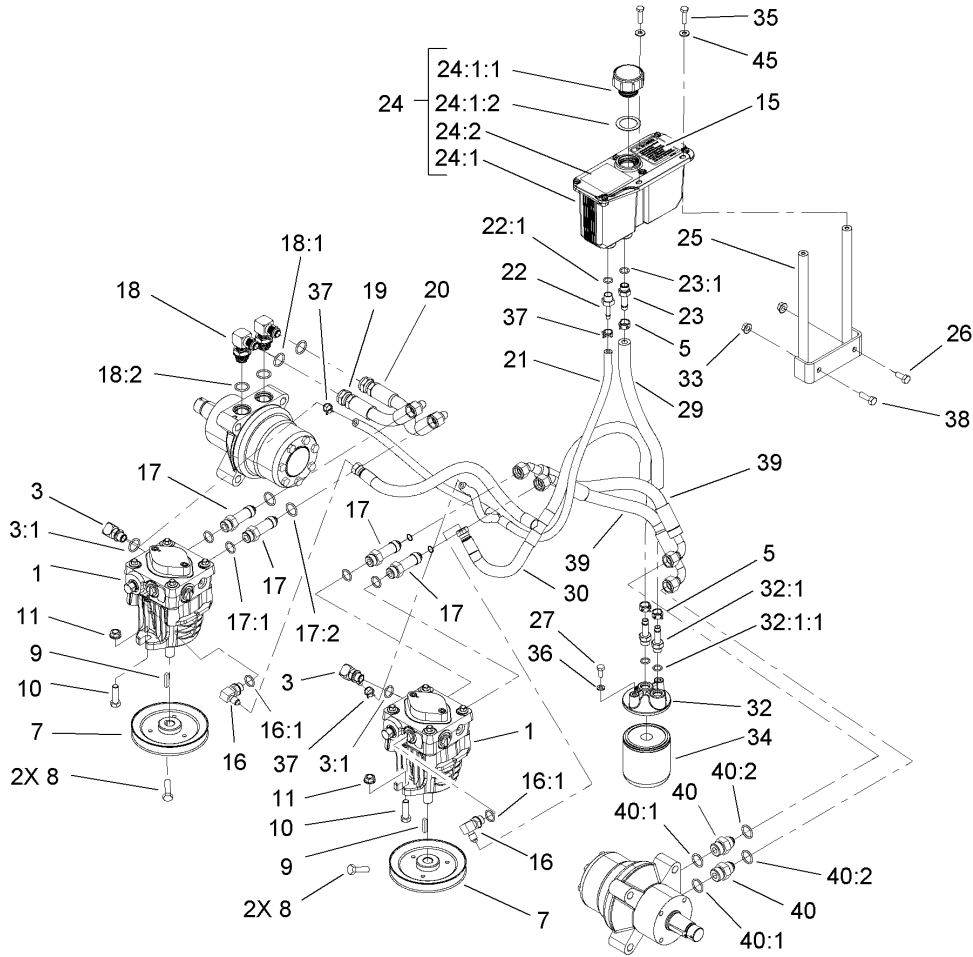

Hydraulic System Assembly

Ref	Part No.	Qty.	Description
1	103-1942	2	Pump-HYD
3	103-1799	2	Elbow-90 DEG
3:1	237-42	1	O-Ring
5	103-1988	3	Clamp-Hose
7	1-653156	2	Pulley
8	1-803050	4	Screw-Set
9	1-807272	2	Key
10	323-7	4	Screw-HH
11	3290-357	4	Nut-HHF
15	103-2644	1	Decal-Exhaust
16	103-1802	2	Fitting-Hyd, 90 DEG
16:1	1-603921	1	O-Ring
17	103-1940	4	Adapter-Hyd, Straight
17:1	237-79	1	O-Ring
17:2	1-603992	1	O-Ring
18	1-633605	2	Fitting-Hyd, 90 DEG
18:1	1-603992	1	O-Ring
18:2	237-80	1	O-Ring
19	1-653186	1	Hose-Front
20	1-653187	1	Hose-Rear, RH
21	103-2357	1	HYD Hose ASM
22	103-1801	1	Adapter-Straight
22:1	237-42	1	O-Ring
23	103-1912	1	Adapter-Straight

Ref	Part No.	Qty.	Description
23:1	237-42	1	O-Ring
24	103-1947	1	HYD Reservoir ASM
24:1		1	Reservoir-HYD
24:1:1	103-1948	1	Cap-Reservoir, HYD
24:1:2	103-1949	1	Gasket-Cap
24:2	1-523552	1	Decal-Tank, HYD
25	103-3071-03	1	Stand-Reservoir
26	322-3	1	Screw-HH
27	321-3	2	Screw-HH
29	103-3077	1	HYD Hose ASM
30	103-2930	1	HYD Hose ASM
32	103-2889	1	Filter Head ASM
32:1	103-1912	2	Adapter-Straight
32:1:1	237-42	1	O-Ring
33	32128-20	2	Nut-HF
34	1-633750	1	Filter-HYD
34	1-633752	1	Filter-Hyd, Winter
35	321-6	2	Screw-HH
36	1-805004	2	Washer-Lock
37	103-1716	3	Clamp-Hose
38	322-5	1	Screw-HH
39	103-3809	2	Hose-LH
40	1-603991	2	Fitting-Straight
40:1	237-80	1	O-Ring

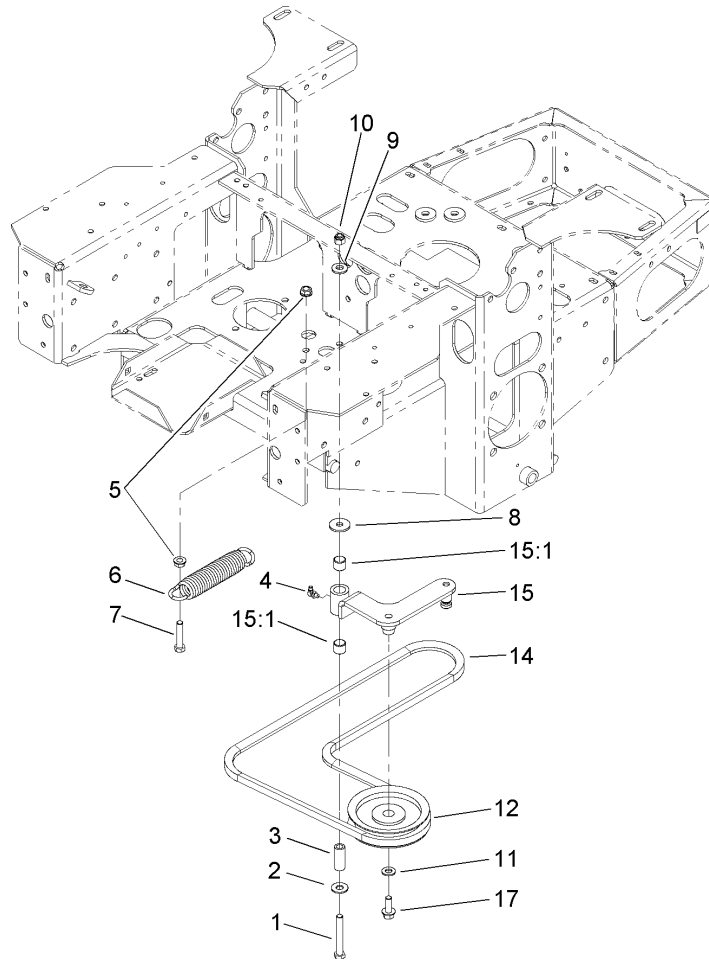

Pump Idler and Belt Assembly

Ref	Part No.	Qty.	Description				
1	323-13	1	Screw-HH				
2	3256-4	1	Washer-Flat				
3	1-603044	1	Bushing				
4	302-40	1	Fitting-Grease				
5	3290-357	2	Nut-HHF				
6	103-4480	1	Spring-Extension				
7	323-9	1	Screw-HH				
8	63-8410	1	Washer				
9	98-5975	1	Washer-Belleville				
10	3296-39	1	Nut-Lock, NI				
11	3256-24	1	Washer-Flat				
12	1-603843	1	Pulley-Idler				
14	107-3960	1	Belt				
15	103-4482	1	Idler Arm ASM				
15:1	103-4681	2	Sleeve-Bearing				
17	3234-11	1	Screw-HHF				

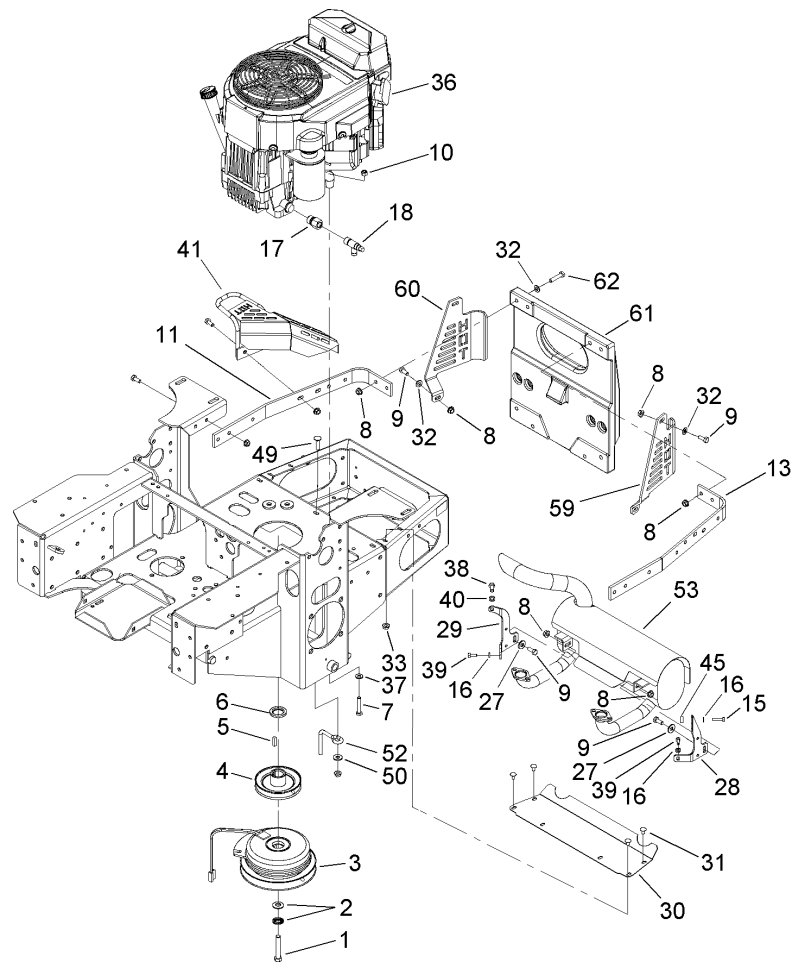

Engine, Clutch and Muffler Assembly

Ref	Part No.	Qty.	Description
1	3212-12	1	Screw-HH
2	1-603610	2	Washer-Spring
3	103-0690	1	Clutch
4	103-3913	1	Pulley
5	1-807259	1	Key
6	103-2308	1	Spacer-Crankshaft
7	322-9	4	Screw-HH
8	32128-20	33	Nut-HF
9	322-3	17	Screw-HH
10	3296-29	4	Nut-Lock, NI
11	103-3078-03	1	Strap-Guard, RH
13	103-3164-03	1	Strap-Guard, LH
15	33113-025	1	Screw-HH
16	1-805004	3	Washer-Lock
17	103-1966	1	Adapter
18	103-1965	1	Valve-Drain, Oil
27	3256-3	3	Washer-Flat
28	103-4477-03	1	Bracket-Muffler, LH
29	103-4478-03	1	Bracket-Muffler, RH
30	103-2740-03	1	Deflector-Short
31	3229-10	4	Screw-CARR
32	3256-23	12	Washer-Flat
33	32128-33	4	Nut-HF
36		1	Engine-Kawasaki, Fh580v-As30

Ref	Part No.	Qty.	Description
37	1-303334	4	Washer-Spring
38	33114-020	1	Screw-HH
39	33113-016	2	Screw-HH
40	1-805005	1	Washer-Lock
41	103-3218-03	1	Guard-Tailpipe
45	103-3096	1	Spacer
49	3230-3	1	Screw-CARR
50	3256-3	1	Washer-Flat
52	108-1058	1	Rod-Belt
53	103-4483	1	Muffler Kit
59	103-3287-03	1	Guard-Muffler, LH
60	103-3288-03	1	Guard-Muffler, RH
61	107-8421-03	1	Weight-Notched, 60 Lb
62	322-7	8	Screw-HH

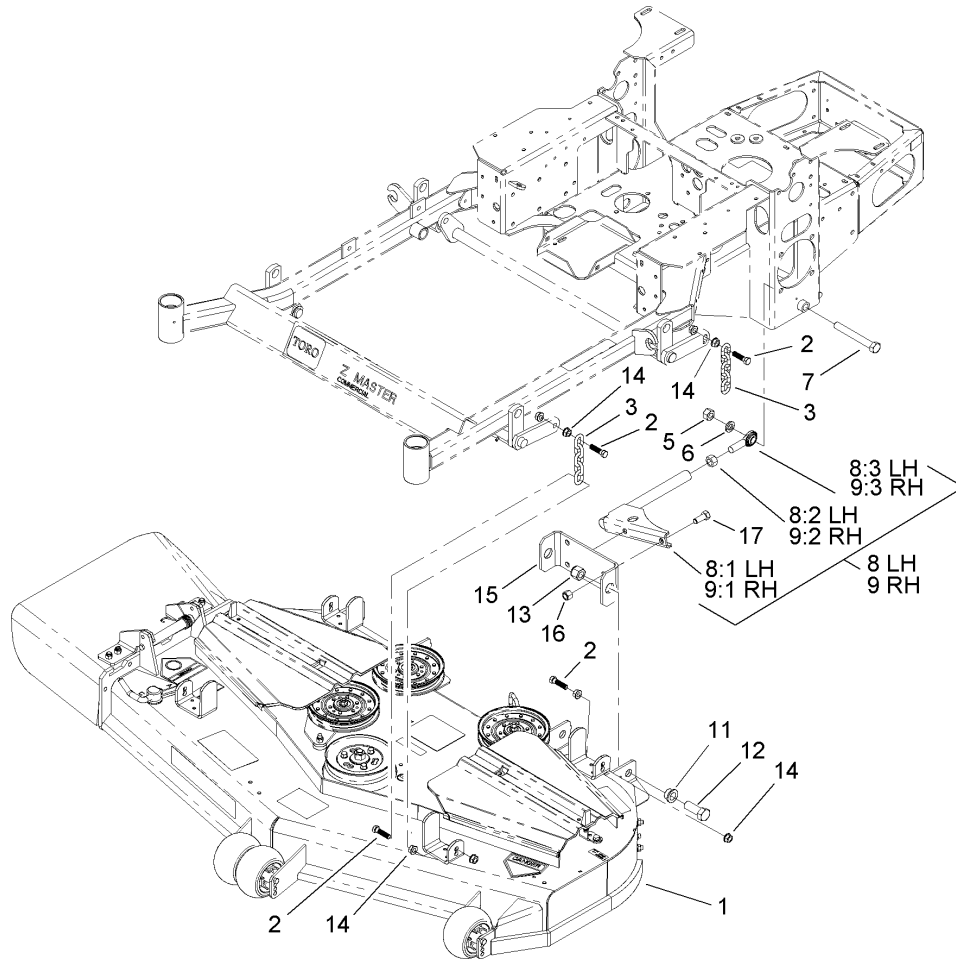

Deck Connection Assembly

Ref	Part No.	Qty.	Description
1	107-3190	1	Deck ASM
2	103-1898	8	Screw-HH
3	1-633447	4	Chain-Lift, Deck
5	3217-11	2	Nut-Hex
6	3253-8	2	Washer-Lock
7	1-800344	2	Screw-HH
8	107-3150	1	LH Strut ASM
8:1	107-3103-01	1	Strut-Compact
8:2	3219-6	1	Nut-Hex
8:3	1-633029	1	Balljoint-Spherical
9	107-1659	1	RH Strut ASM
9:1	107-3103-01	1	Strut-Compact
9:2	1-633029	1	Balljoint-Spherical
9:3	3219-6	1	Nut-Hex
11	93-2877	4	Bushing
12	328-24	4	Screw-HH
13	3296-51	4	Nut-Lock, NI
14	32128-37	16	Nut-HF
15	107-3100-01	2	Base-Strut
16	3296-23	4	Nut-Lock, NI
17	325-5	4	Screw-HH

--	--	--	--

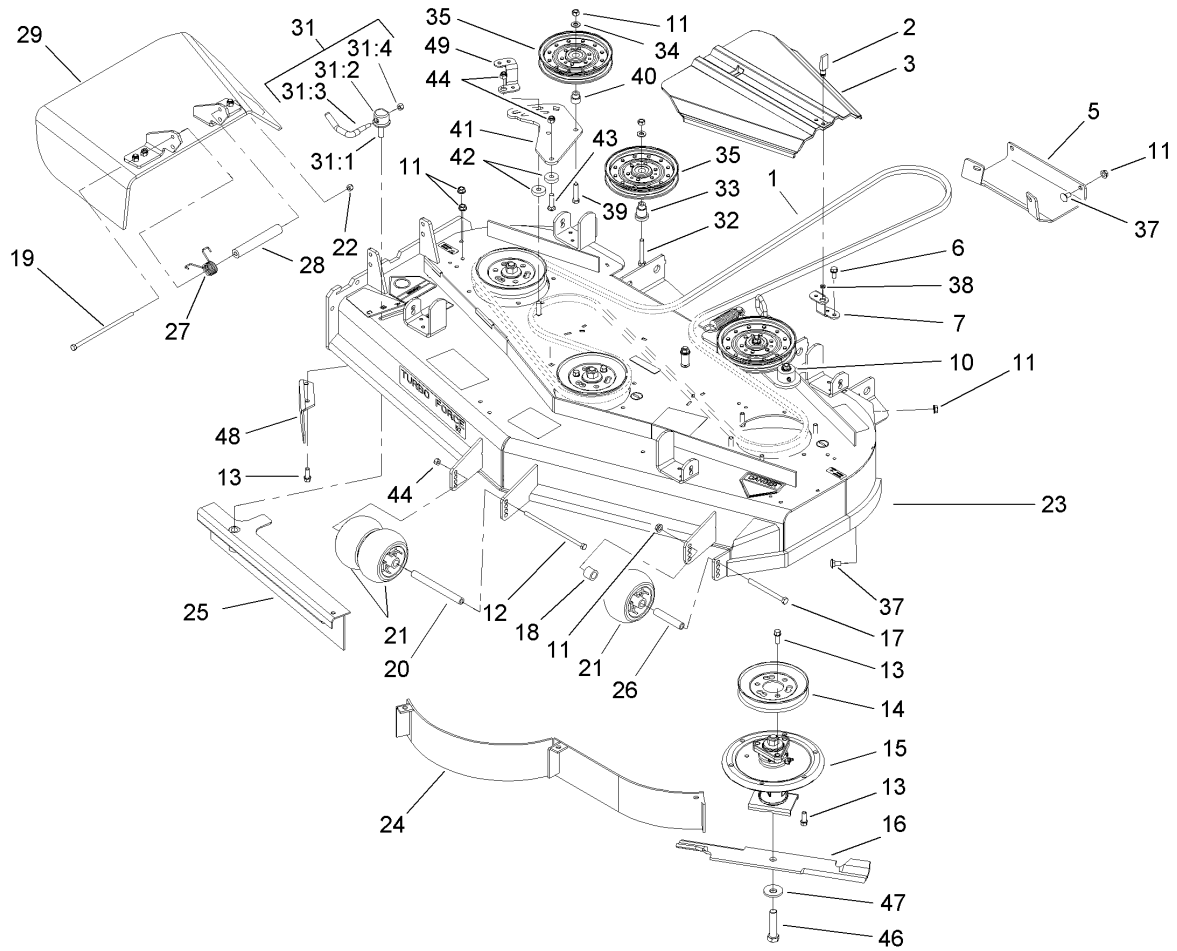

Deck Assembly No. 107-1670

Ref	Part No.	Qty.	Description
1	106-7369	1	Belt-V
2	74-5950	2	Latch-Swell
3	107-8536	2	Cover-Belt
5	106-7358-01	1	Plate-Skid
6	32144-70	3	Screw-HH
7	108-2177-01	3	Bracket-Cover, Tall
10		1	Idler ASM
11	3290-357	36	Nut-HHF
12	323-28	1	Screw-HH
13	92-1624	33	Screw
14	107-1683	3	Pulley
15	107-8504	3	Spindle ASM
16	105-7781-03	3	Blade-Hi Flow, 18in
17	323-23	1	Screw-HH
18	98-7913	1	Tube-Spacer
19	322-50	1	Screw-HH
20	98-5967	1	Spacer-Wheel
21	1-603299	3	Roller-Anti Scalp
22	3296-29	1	Nut-Lock, NI
23	107-1669	1	Deck Decal ASM
24	105-7754-01	1	Baffle ASM
25	105-7755-01	1	Baffle ASM
26	98-7912	1	Tube-Spanner
27	107-1663	1	Spring-Torsion

Ref	Part No.	Qty.	Description
28	105-4622	1	Spacer
29	108-4060	1	Rubber Deflector ASM
31	107-1664	1	Lever ASM
31:1	106-3239	1	Screw-Lock
31:2	107-1644	1	Cap-Lock
31:3	106-3241	1	Lever-Lock
31:4	3296-29	1	Nut-Lock, NI
32	323-12	1	Screw-HH
33	106-3214	1	Mount-Pulley
34	3256-24	3	Washer-Flat
35	1-633109	2	Idler-Flat
37	3231-1	10	Screw-CARR
38	99-3058	2	Washer
39	323-9	1	Screw-HH
40	1-603496	1	Bushing-Idler
41	107-8516-01	1	Plate-Idler
42	105-7788	2	Spacer
43	3231-4	2	Screw-CARR
44	3296-39	6	Nut-Lock, NI
46	103-0862	3	Screw-Cap
47	103-0865	3	Washer-Blade Bolt, Heavy
48	106-3216-01	1	Baffle-Discharge
49	108-2178-01	1	Bracket-Cover, Short
99	105-7779-03	3	Blade-Recycler

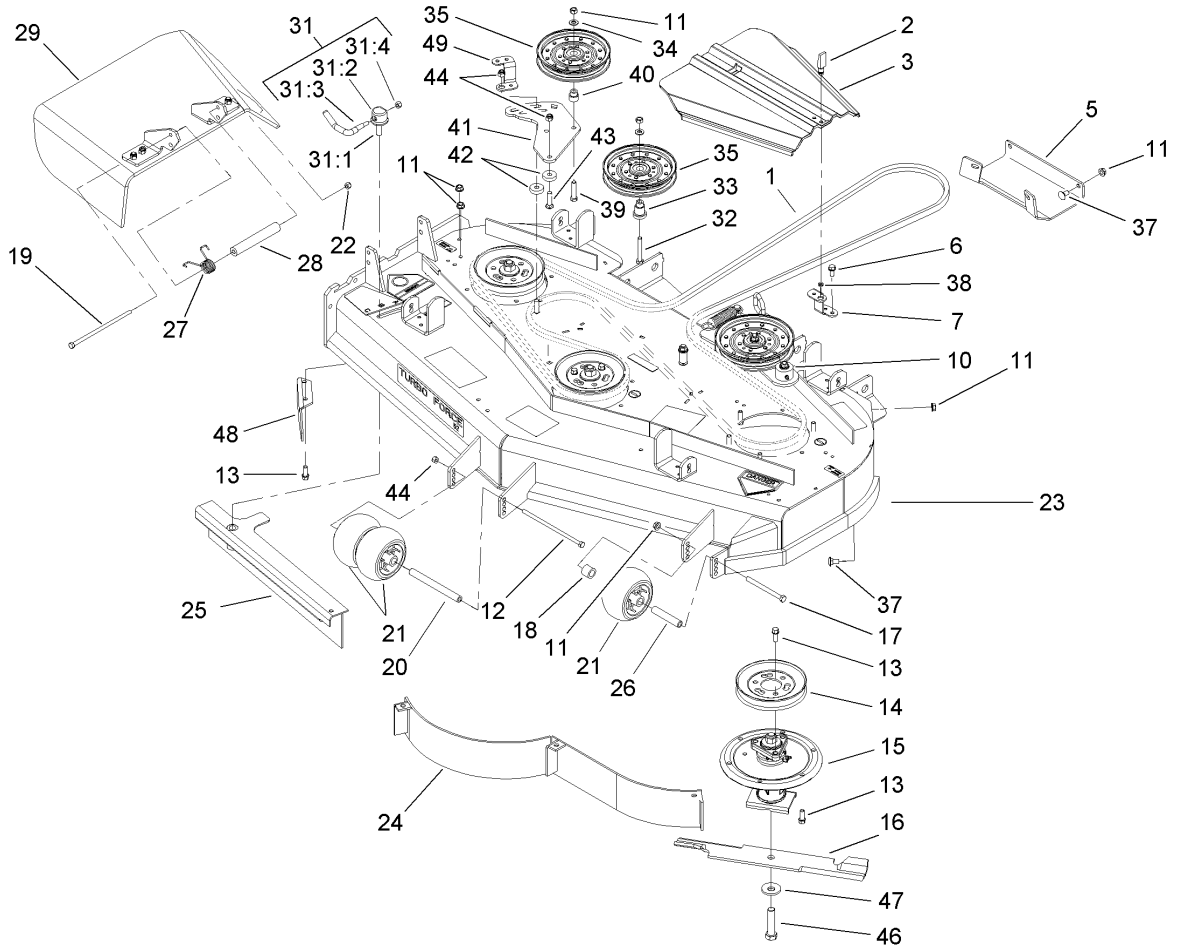

Deck Assembly No. 107-1670 (continued)

Ref	Part No.	Qty.	Description
●99	105-7794-03	3	Blade-Med Flow
●99	105-7795-03	3	Blade-Low Flow
●99	105-7796-03	3	Blade-Atomic

--	--	--	--

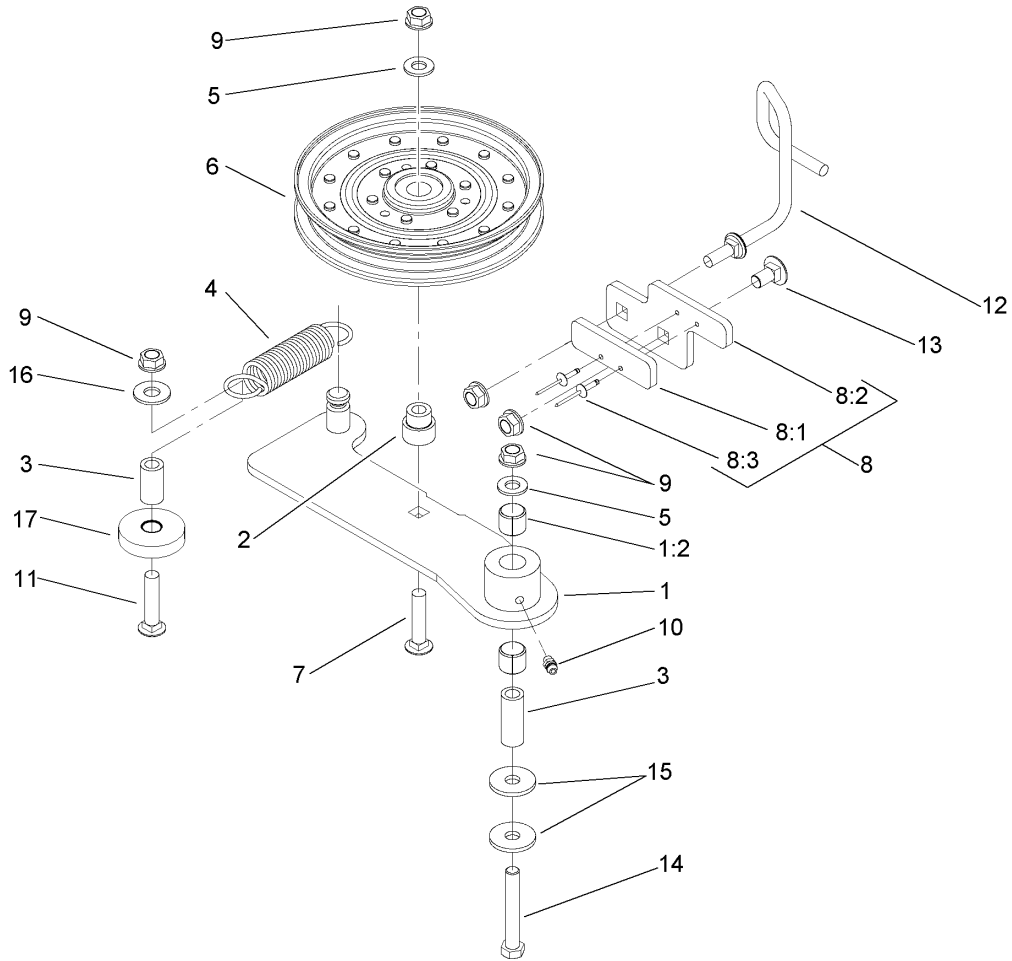

Idler Assembly

Ref	Part No.	Qty.	Description
1	108-4062	1	Idler Arm ASM
1:2	103-4681	2	Sleeve-Bearing
2	1-603496	1	Bushing-Idler
3	1-603044	2	Bushing
4	1-603402	1	Spring-Extension
5	3256-24	2	Washer-Flat
6	1-633109	1	Idler-Flat
7	3231-6	1	Screw-CARR
8		1	Stop Pad ASM
8:1	106-3229	1	Pad-Bumber
8:2	107-1697-01	1	Plate-Stop
8:3	3269-24	2	Rivet
9	3290-357	5	Nut-HHF
10	302-5	1	Fitting-Grease
11	3231-31	1	Screw-CARR
12	108-4072	1	Guide-Belt
13	3231-1	1	Screw-CARR
14	323-12	1	Screw-HH
15	2844	2	Washer
16	3256-4	1	Washer-Flat
17	108-2239	1	Stop-Plastic

--	--	--	--

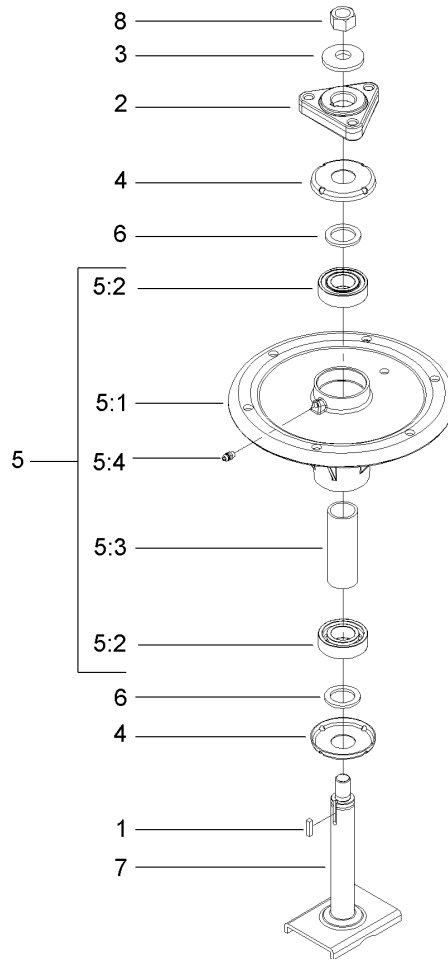

Spindle Assembly No. 107-8504

Ref	Part No.	Qty.	Description
1	10-8040	1	Key-Square
2	106-3277	1	Hub-Pulley
3	103-0865	1	Washer-Blade Bolt, Heavy
4	106-3204	2	Shield-Bearing
5		1	Spindle Bearing ASM
5:1	106-3211	1	Housing-Spindle
5:2	113514	2	Bearing-Ball
5:3	107-8502	1	Spacer-Bearing
5:4	302-5	1	Fitting-Grease
6	3-8514	2	Washer-Thrust
7	107-8501	1	Spindle ASM
8	3219-6	1	Nut-Hex

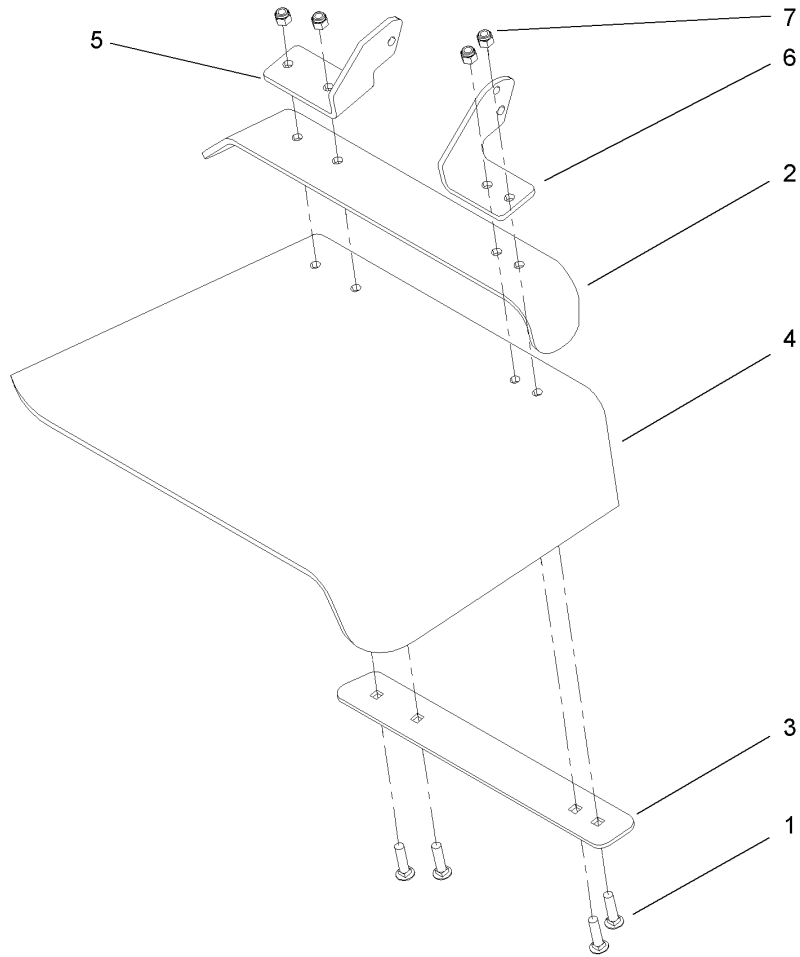

Rubber Deflector Assembly No. 108-4060

Ref	Part No.	Qty.	Description				
1	3231-4	4	Screw-CARR				
2	106-3246-01	1	Deflector				
3	106-3248-03	1	Strap-Discharge				
4	107-1617	1	Deflector-Rubber				
5	108-4059-01	1	Plate-Hinge, Rear				
6	108-4058-01	1	Plate-Hinge, Front				
7	3296-39	4	Nut-Lock, NI				

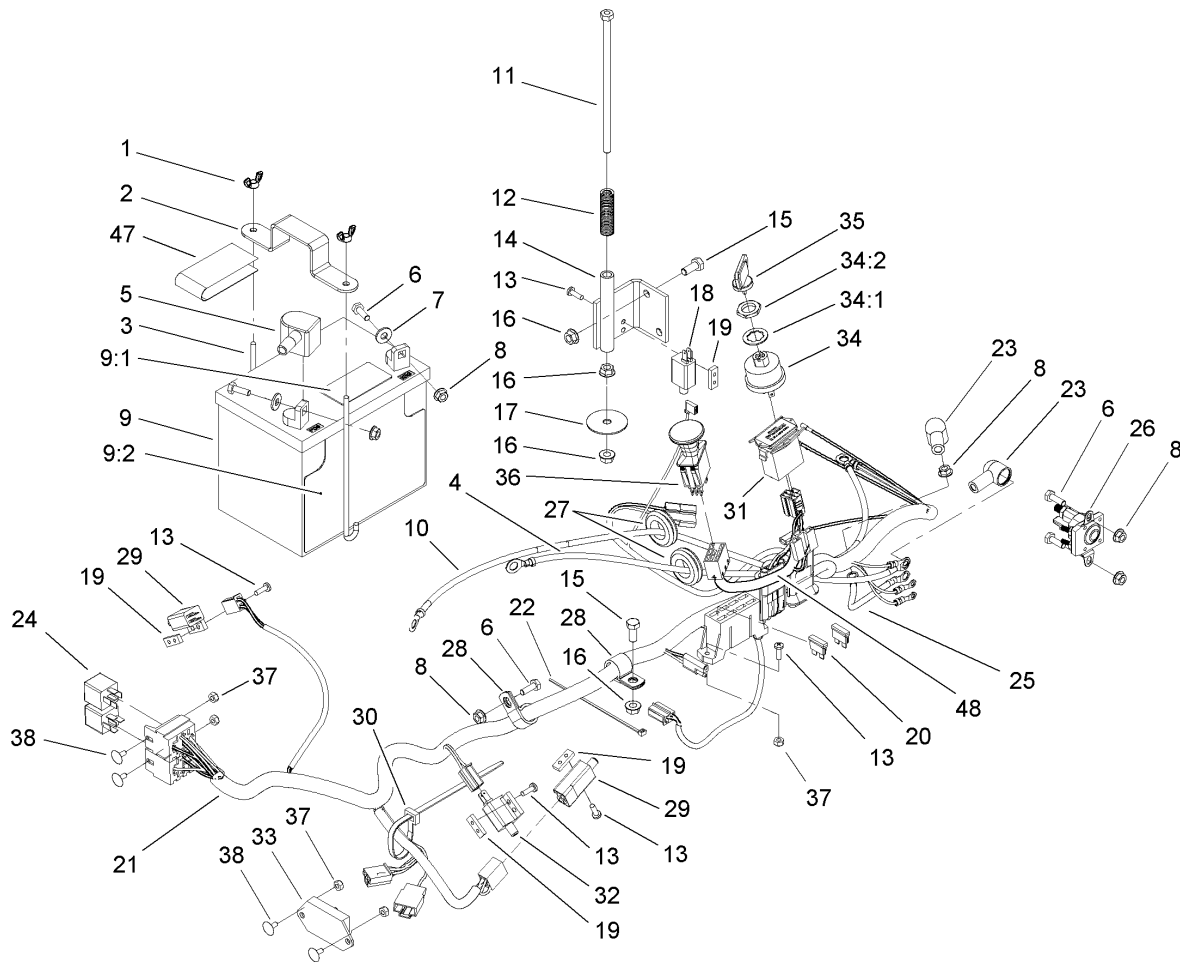

Electrical System Assembly

Ref	Part No.	Qty.	Description
1	1-543792	2	Wingnut
2	1-633652-03	1	Strap-Holddown
3	1-633651	2	Bolt-Holddown
4	103-0705	1	Cable-Ground, Negative
5	1-543391	1	Insulator-Battery
6	321-4	5	Screw-HH
7	3256-2	2	Washer-Flat
8	32128-33	6	Nut-HF
9	105-1692	1	Battery
9:1	104-4163	1	Decal-Battery
9:2	104-4164	1	Decal-Battery
10	103-0707	1	Cable-Battery, Positive
11	1-800282	1	Screw-HH
12	1-523415	1	Spring-Switch, Seat
13	1-803075	10	Screw-Head, Truss
14	1-652072-03	1	Bracket-Switch, Seat
15	322-3	3	Screw-HH
16	32128-20	5	Nut-HF
17	1-653036	1	Washer
18	1-513152	1	Switch-Closed, Normally
19	1-633181	4	Plate-Tapped
20	1-816001	2	Fuse-Blade Type, 20 Amp
21	107-8051	1	Harness-Electrical
22	1-303287	3	Tie-Plastic

Ref	Part No.	Qty.	Description
23	1-543393	3	Insulator-Solenoid
24	1-643275	2	Relay
25	1-633306	1	Wire-Starter
26	1-513075	1	Switch-Solenoid
27	1-543286	3	Grommet
28	1-633396	2	Clip-Loom
29	1-513051	2	Switch-Open, Normally
30	1-303335	4	Tie-Plastic
31	1-513374	1	Meter-Hour
32	1-633111	1	Switch
33	100-6186	1	Module-Delay, Seat
34	88-9830	1	Key Switch ASM
34:1	3254-5	1	Washer-Tooth
34:2	218-461	1	Nut-HH
35	63-8360	2	Key-Ignition
36	1-633673	1	Switch-Delta
37	3296-2	6	Nut-Lock
38	1-807513	4	Bolt-CARR
47	107-9309	1	Decal-Instructions, Charging
48	107-8054	1	Harness-Electrical, Control Panel

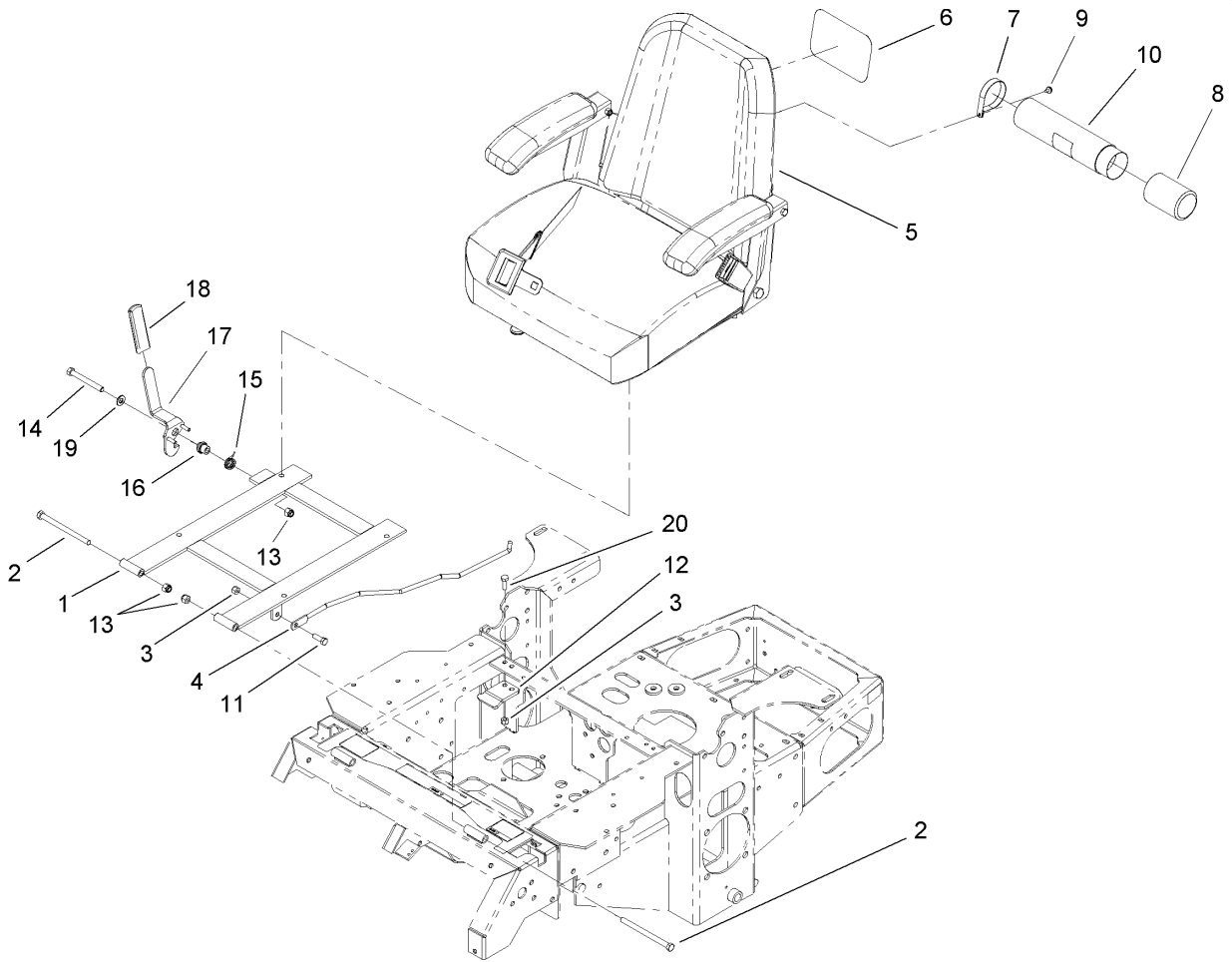

Seat and Bracket Assembly

Ref	Part No.	Qty.	Description				
1	107-3052-03	1	Seat Support Frame ASM				
2	323-39	2	Screw-HH				
3	3296-29	3	Nut-Lock, NI				
4	103-1731	1	Rod-Retainer, Seat				
5	107-1867	1	Seat ASM				
6	99-4693	1	Decal				
7	2412-120	2	R-Clamp				
8	104-7048	1	Cap-Housing				
9	32104-76	2	Screw				
10	104-7050	1	Housing-Manual				
11	322-5	1	Screw-HH				
12	103-5961	1	Catch-Latch, Seat				
13	3296-39	3	Nut-Lock, NI				
14	323-20	1	Screw-HH				
15	107-0076	1	Spring-Torsion				
16	107-0075	1	Bushing-Latch, Seat				
17	107-3083	1	Latch ASM				
18	62-9130	1	Grip-Handle				
19	3256-24	1	Washer-Flat				
20	322-4	2	Screw-HH				

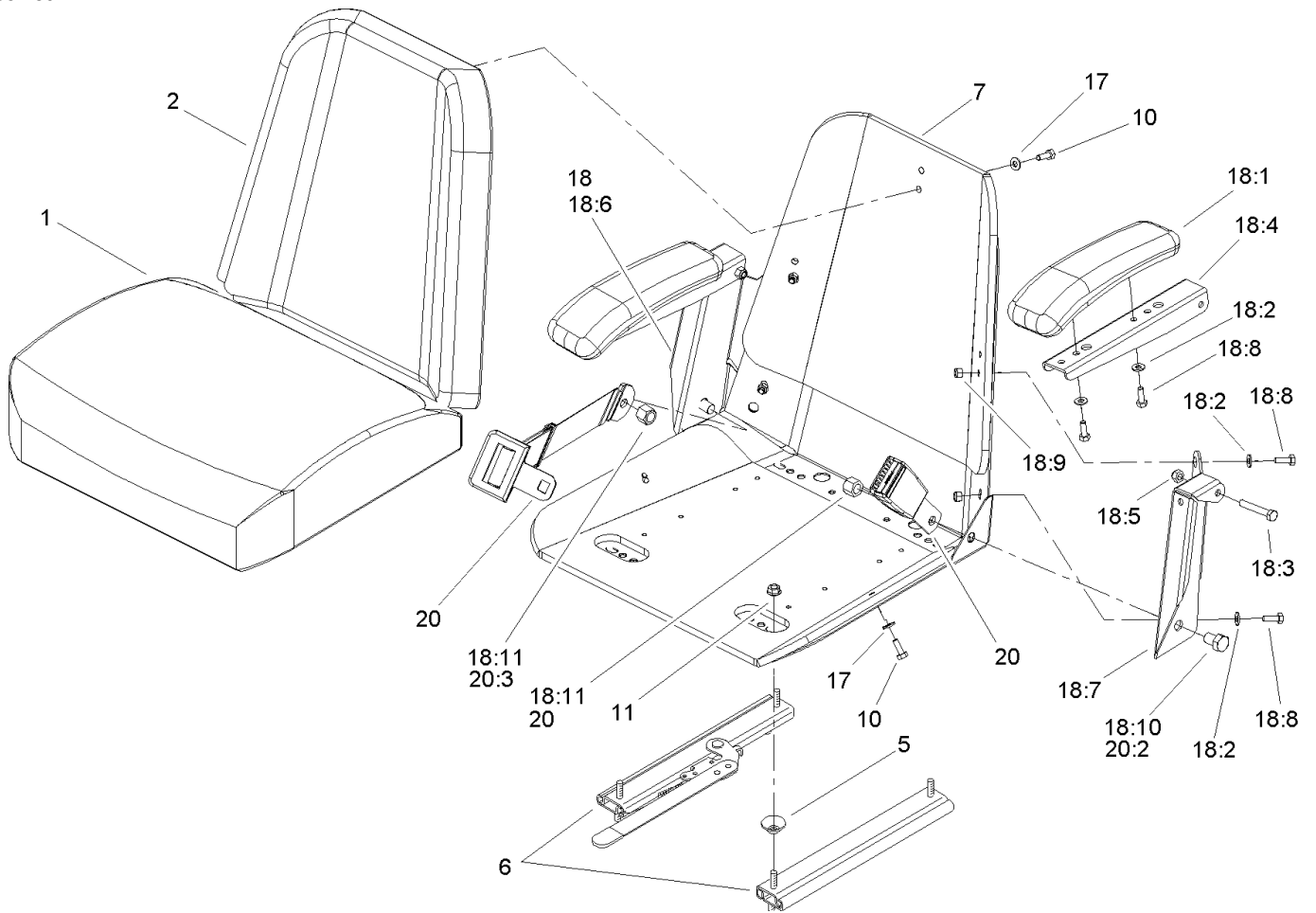

Seat Assembly No. 107-1867

Ref	Part No.	Qty.	Description
1	103-0290	1	Cushion-Seat, Bottom
2	104-7754	1	Cushion-Seat, Back
5	1-543401	4	Spacer-Track
6	1-643255	1	Track-Seat
7	1-633859	1	Frame-Seat
10	321-30	11	Screw-HH
11	32128-20	4	Nut-HF
17	3256-22	11	Washer-Flat
18	105-3620	1	Armrest Kit
18:1	1-633710	2	Cushion-Armrest
18:2	3256-22	4	Washer-Flat
18:3	322-10	2	Screw-HH
18:4	105-3623	2	Channel-Armrest
18:5	32153-3	2	Nut-Lock, Side
18:6	105-3621	1	Bracket-Armrest, RH
18:7	105-3622	1	Bracket-Armrest, LH
18:8	321-30	6	Screw-HH
18:9	3296-42	4	Nut-Lock, NI
18:10	325-2	2	Screw-HH
18:11	3296-23	2	Nut-Lock, NI
20	103-4469	1	Seatbelt Kit
20:2	3212-4	2	Screw-HH
20:3	3296-38	2	Nut-Lock NI

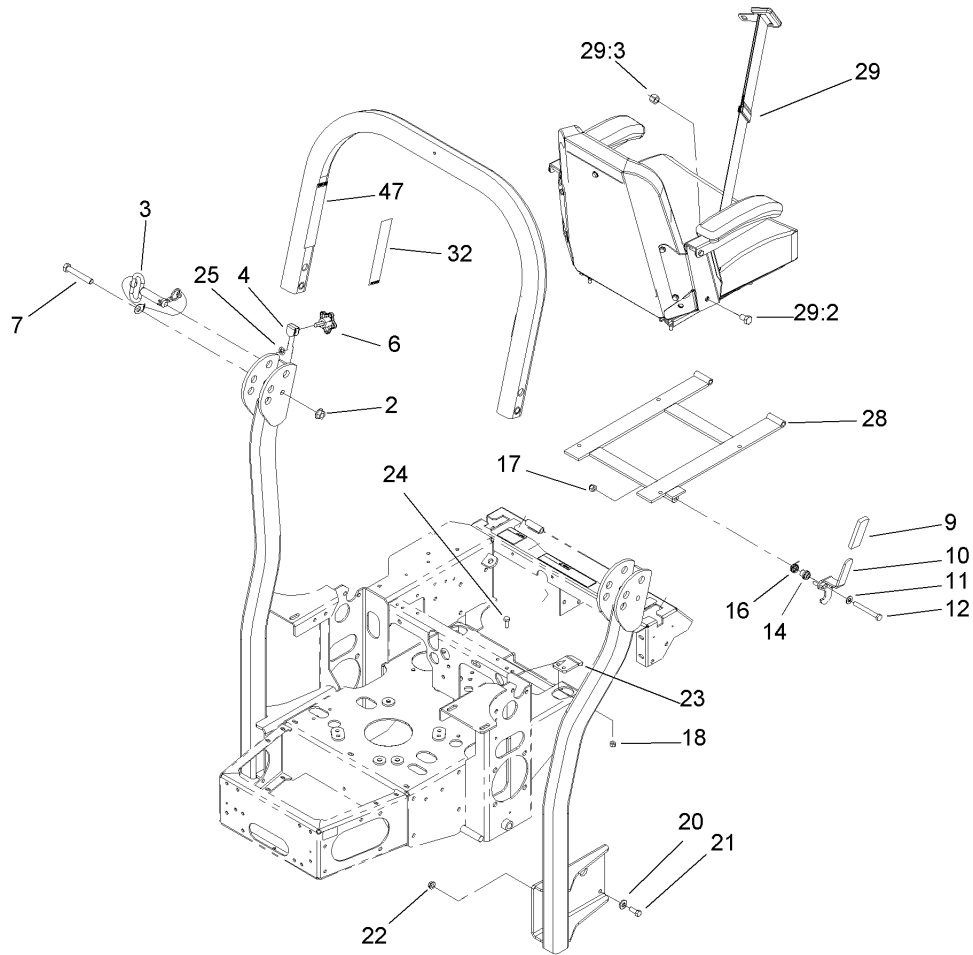

Roll-Over-Protection-System Assembly No. 107-8093

Ref	Part No.	Qty.	Description
2	32128-23	2	Nut-HF
3	103-4553	2	Rops Fold Pin ASM
4	107-3124	2	Clip
6	106-0887	2	Knob
7	325-13	2	Screw-HH
9	62-9130	1	Grip-Handle
10	107-3083	1	Latch ASM
11	3256-24	1	Washer-Flat
12	323-20	1	Screw-HH
14	107-0075	1	Bushing-Latch, Seat
16	107-0076	1	Spring-Torsion
17	3296-39	1	Nut-Lock, NI
18	3296-29	2	Nut-Lock, NI
20	98-5975	8	Washer-Belleveille
21	323-6	8	Screw-HH
22	3290-357	8	Nut-HHF
23	107-3059	1	Catch-Latch, Seat
24	322-4	2	Screw-HH
25	107-3154	2	Nut-Push
28	107-3052-03	1	Seat Support Frame ASM
29	103-4469	1	Seatbelt Kit
29:2	3212-4	2	Screw-HH
29:3	3296-38	2	Nut-Lock NI
32	107-3069	1	Decal-Warning, Folding Rops

Ref	Part No.	Qty.	Description
47	107-2102	1	Decal-Warning, Folding Rops

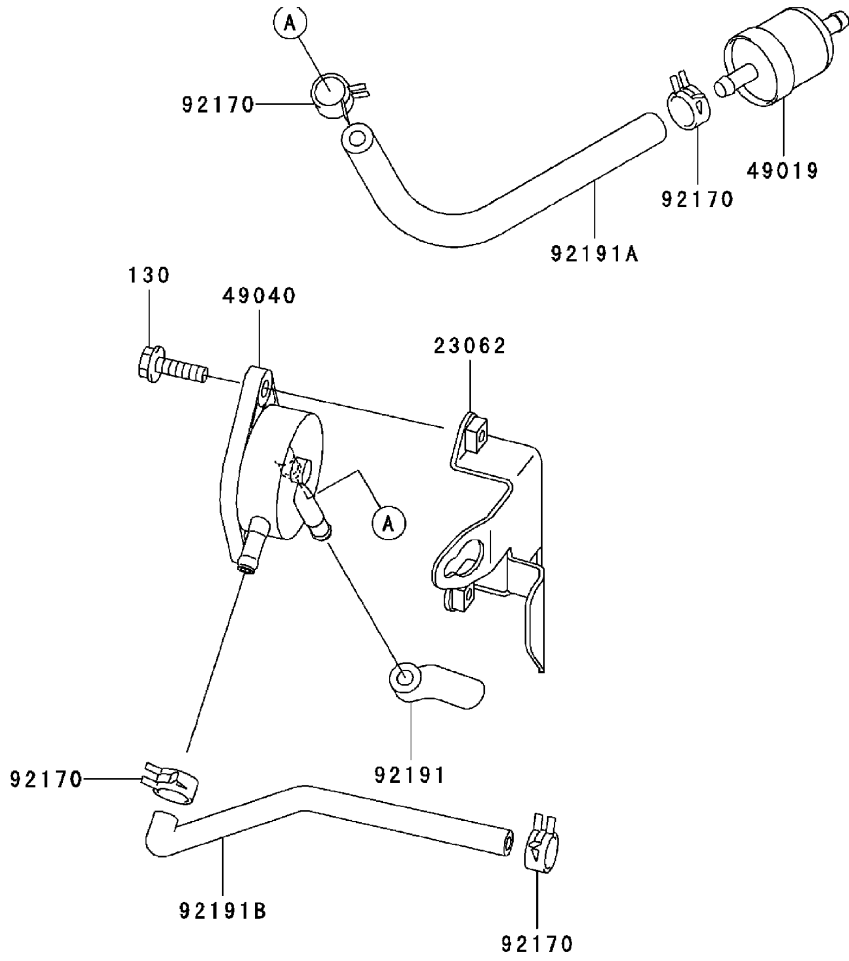

Fuel Tank/Fuel Valve Assembly Kawasaki FH580V AS30

Ref	Part No.	Qty.	Description				
③23062	23062-7004-9H	1	Bracket-Comp				
③49019	49019-7001	1	Filter-Fuel				
③49040	49040-7001	1	Pump-Fuel				
③92170	92170-2088	4	Clamp				
③92191	92191-7002	1	Tube				
③92191A	92191-7003	1	Tube (6.35x12.7x160)				
③92191B	92191-7004	1	Tube				
③130	130B0620	2	Bolt-Flanged				

Cylinder/Crankcase Assembly Kawasaki FH580V AS30

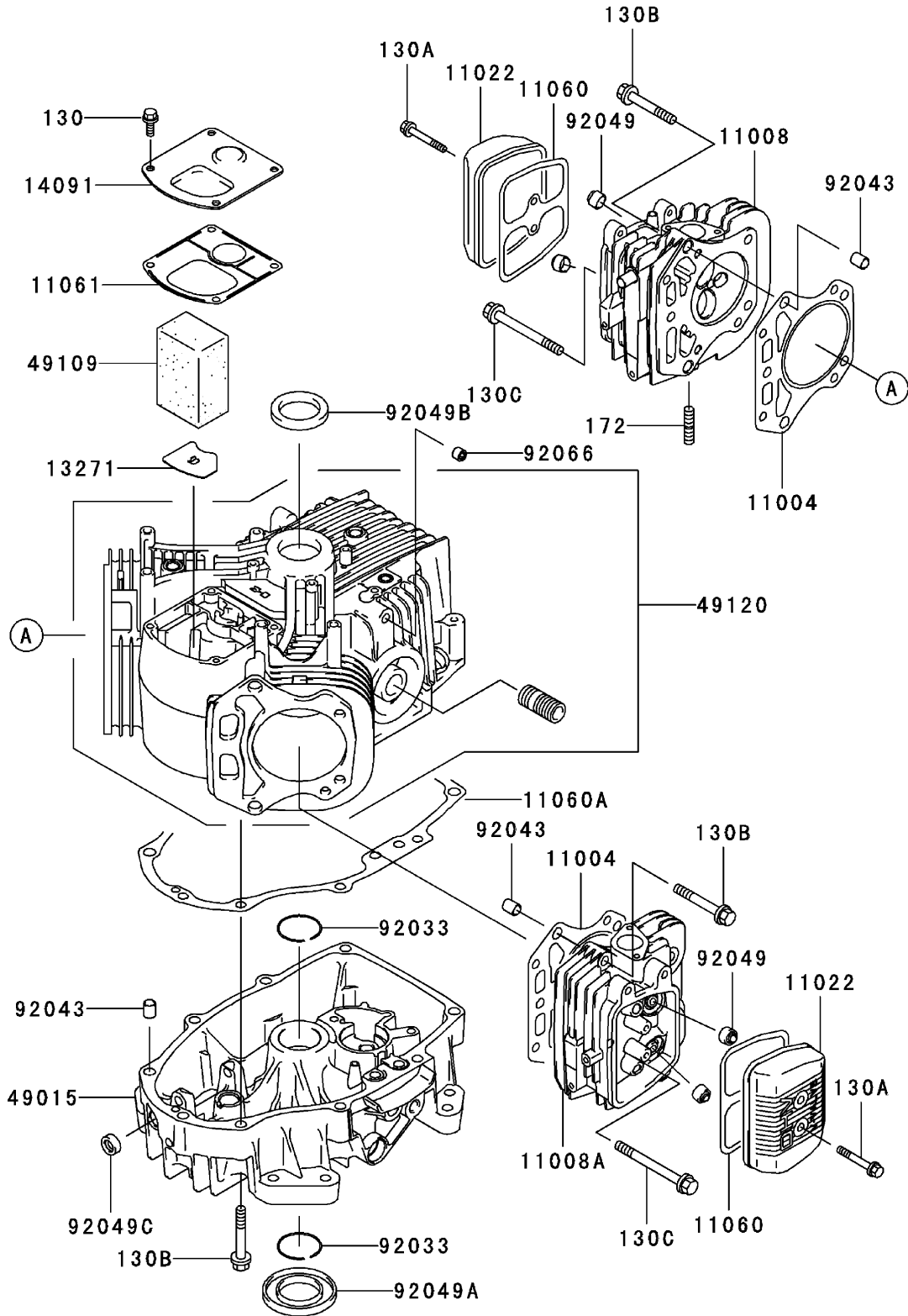

Cylinder/Crankcase Assembly Kawasaki FH580V AS30

Ref	Part No.	Qty.	Description				
⑤11004	11004-7016	2	Gasket-Head				
⑤11008	11008-6043	1	Head-Cylinder, No. 1				
⑤11008A	11008-7020	1	Head-Cylinder, No. 2				
⑤11022	11022-7003	2	Case-Rocker				
⑤11060	11060-7001	2	Gasket-Case, Rocker				
⑤11060A	11060-7008	1	Gasket-Cover, Crankcase				
⑤11061	11061-7001	1	Gasket-Breather				
⑤13271	13271-7016	1	Plate				
⑤14091	14091-7006	1	Cover				
⑤49015	49015-6253	1	Cover-Crankcase				
⑤49109	49109-7002	1	Element-Breather				
⑤49120	49120-7023	1	Crankcase-Comp				
⑤92033	92033-7003	2	Ring-Snap				
⑤92043	92043-7001	6	Pin				
⑤92049	92049-7001	4	Seal-Oil, Rvc2 (6x11x10.2)				
⑤92049A	92049-7015	1	Seal-Oil, Sd (35x62x8 L Hs)				
⑤92049B	92049-7016	1	Seal-Oil, Sd (35x48x8 R Hs)				
⑤92049C	92049-7019	1	Seal-Oil, So (8x14x5 Hs)				
⑤92066	92066-7002	1	Plug				
⑤130	130B0612	4	Bolt-Flanged				
⑤130A	130B0640	4	Bolt-Flanged				
⑤130B	130T0850	17	Bolt-Flanged				
⑤130C	130T0875	2	Bolt-Flanged				
⑤172	172G0818	4	Bolt-Stud				

Piston/Crankshaft Assembly Kawasaki FH580V AS30

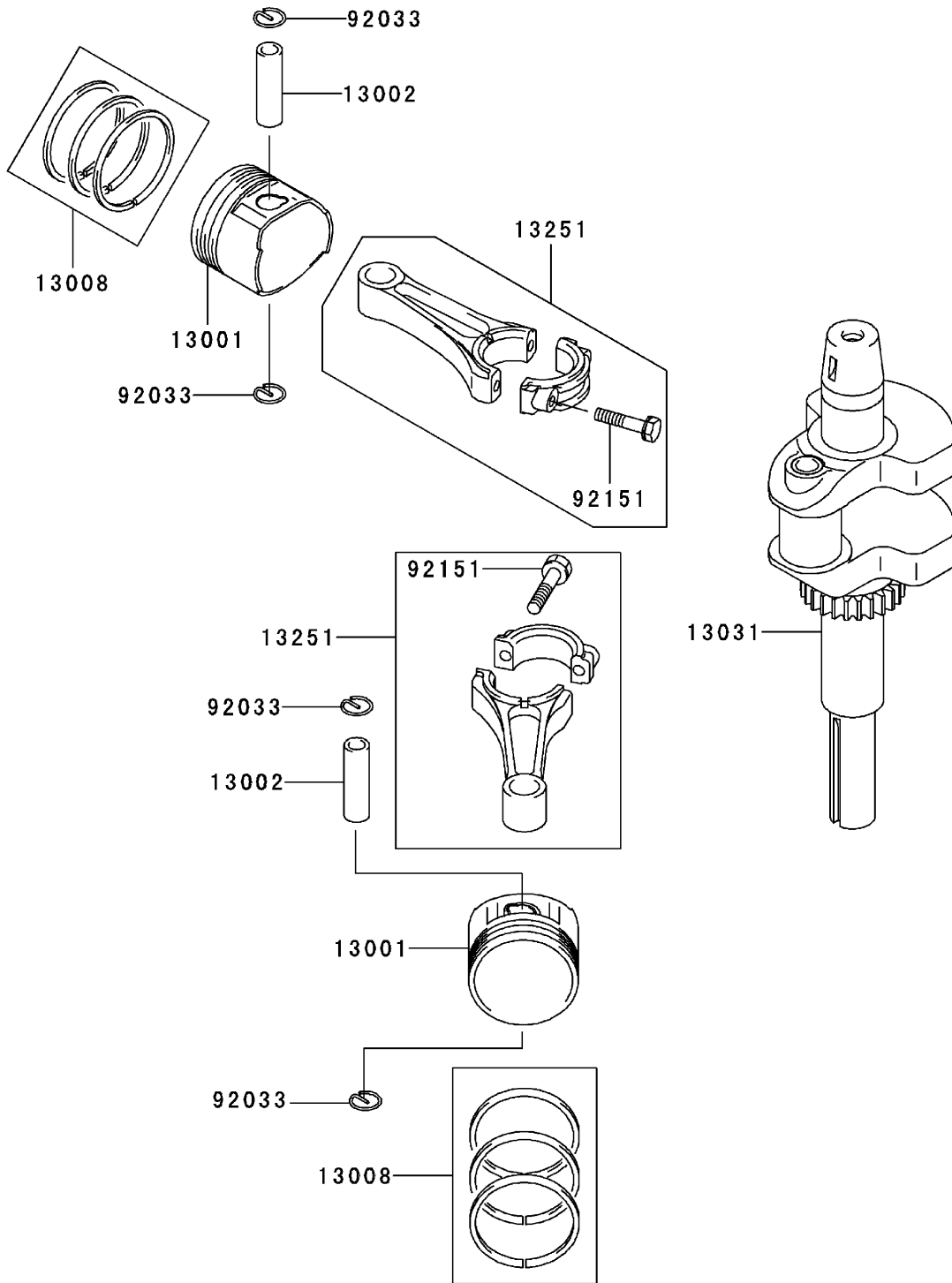

Piston/Crankshaft Assembly Kawasaki FH580V AS30

Ref	Part No.	Qty.	Description				
①13001	13001-7010	2	Piston-Engine				
①13002	13002-7001	2	Pin-Piston				
①13008	13008-6060	2	Piston Ring Set				
①13031	13031-7036	1	Crankshaft-Comp				
①13251	13251-7010	2	Connecting Rod ASM				
①92033	92033-7005	4	Ring-Snap				
①92151	92151-7017	4	Bolt (6x35)				

Valve/Camshaft Assembly Kawasaki FH580V AS30

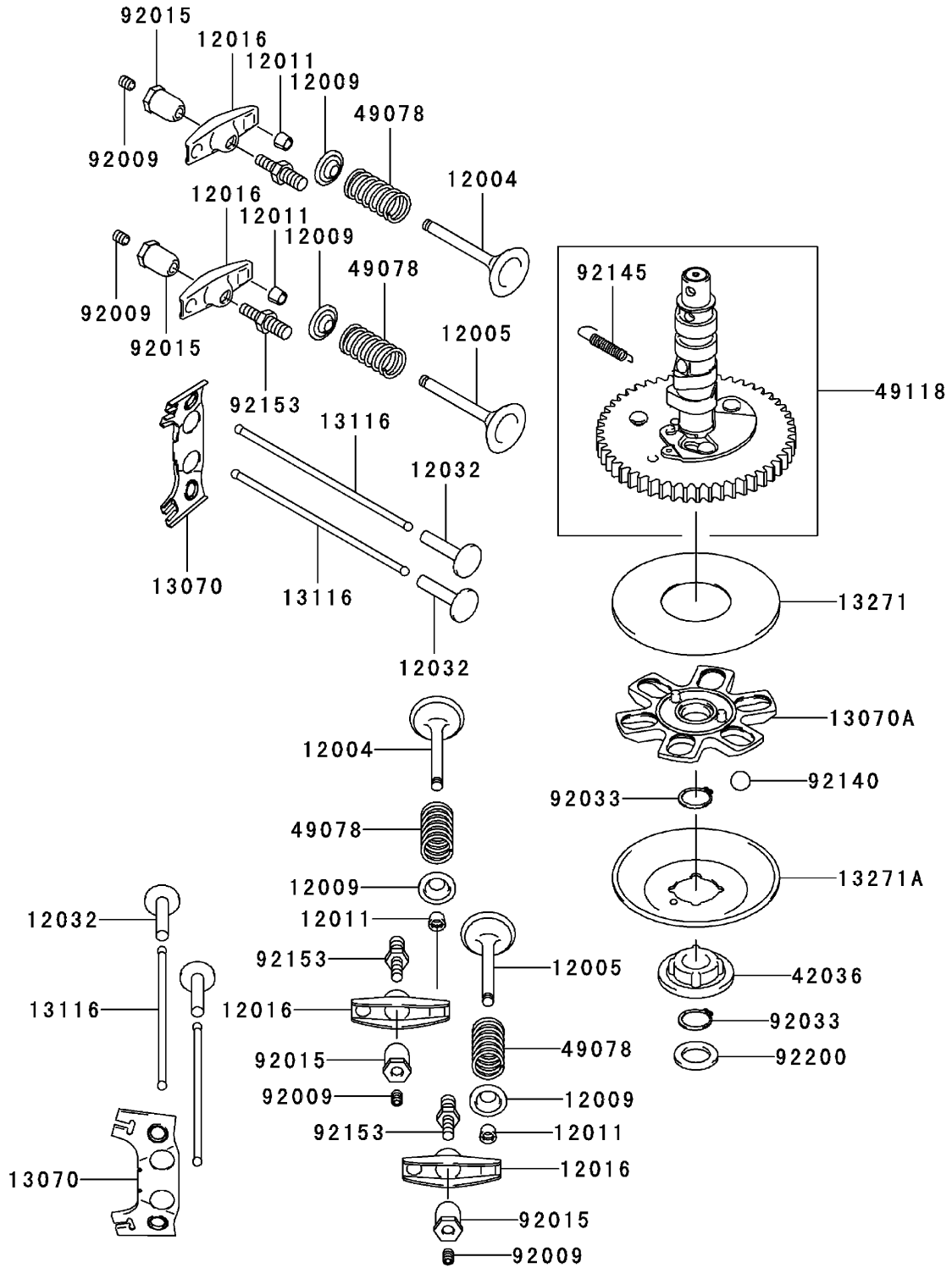

Valve/Camshaft Assembly Kawasaki FH580V AS30

Ref	Part No.	Qty.	Description				
⑤12004	12004-7003	2	Valve-Intake				
⑤12005	12005-7003	2	Valve-Exhaust				
⑤12009	12009-7001	4	Retainer-Spring, Valve				
⑤12011	12011-2056	8	Collet				
⑤12016	12016-7001	4	Arm-Rocker				
⑤12032	12032-7001	4	Tappet				
⑤13070	13070-7001	2	Guide				
⑤13070A	13070-7004	1	Guide				
⑤13116	13116-2057	4	Rod-Push				
⑤13271	13271-7007	1	Plate				
⑤13271A	13271-7021	1	Plate-Governor				
⑤42036	42036-7009	1	Sleeve				
⑤49078	49078-7001	4	Spring-Valve, Engine				
⑤49118	49118-7004	1	Camshaft-Comp				
⑤92009	92009-2341	4	Screw				
⑤92015	92015-2253	4	Nut				
⑤92033	92033-7001	2	Ring-Snap				
⑤92140	92140-7002	6	Ball				
⑤92145	92145-7001	1	Spring				
⑤92153	92153-7019	4	Bolt				
⑤92200	92200-7001	1	Washer				

Lubrication Equipment Assembly Kawasaki FH580V AS30

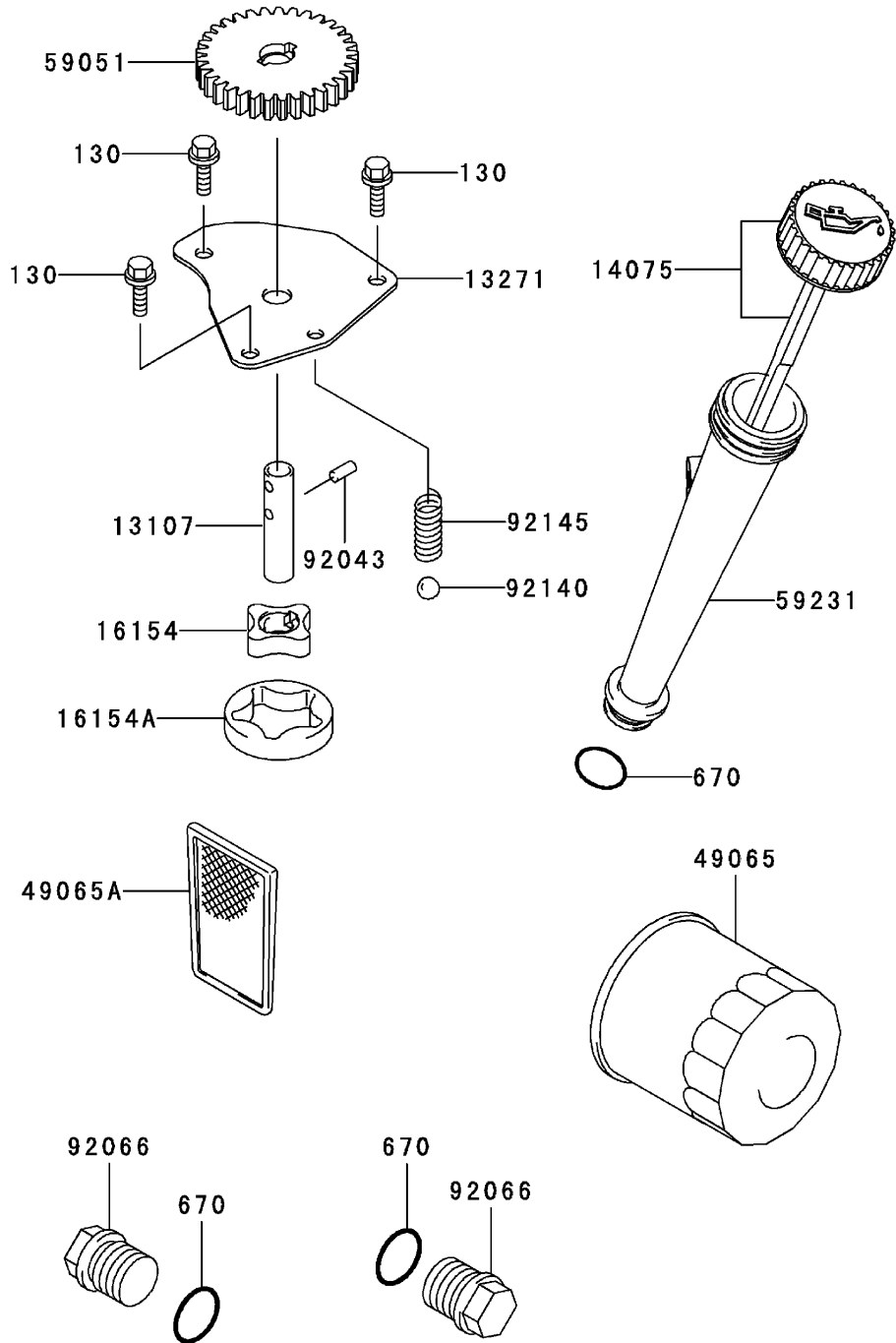

Lubrication Equipment Assembly Kawasaki FH580V AS30

Ref	Part No.	Qty.	Description				
⑤13107	13107-7009	1	Shaft				
⑤13271	13271-7017	1	Plate				
⑤14075	14075-7009	1	Cap ASM				
⑤16154	16154-2053	1	Rotor-Pump (In)				
⑤16154A	16154-2054	1	Rotor-Pump (Out)				
⑤49065	49065-2078	1	Filter-Oil				
⑤49065A	49065-7004	1	Filter-Oil				
⑤59051	59051-7011	1	Gear-Spur				
⑤59231	59231-7005	1	Filler				
⑤92043	92043-7003	2	Pin				
⑤92066	92066-7003	2	Plug				
⑤92140	92140-7003	1	Ball				
⑤92145	92145-7002	1	Spring				
⑤130	130B0612	3	Bolt-Flanged				
⑤670	670D2016	3	O-Ring (16mm)				

Cooling Equipment Assembly

Kawasaki FH580V AS30

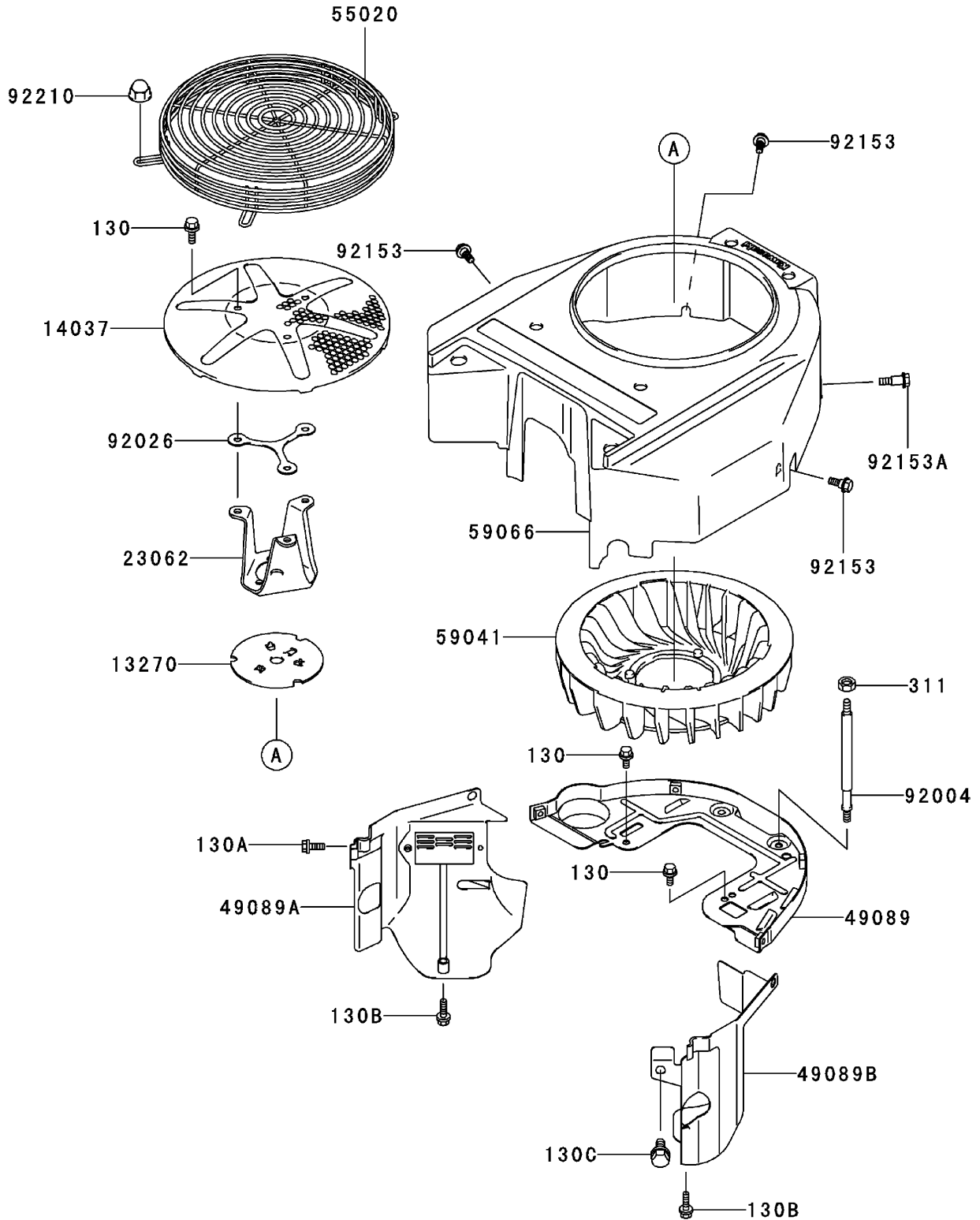

Cooling Equipment Assembly Kawasaki FH580V AS30

Ref	Part No.	Qty.	Description				
③13270	13270-7007	1	Plate				
③14037	14037-7020-9H	1	Screen				
③23062	23062-7010	1	Bracket-Comp				
③49089	49089-7032	1	Shroud-Engine				
③49089A	49089-7042	1	Shroud-Engine				
③49089B	49089-7043	1	Shroud-Engine				
③55020	55020-7004	1	Guard				
③59041	59041-7010	1	Fan				
③59066	59066-7024	1	Housing-Fan				
③92004	92004-7006	2	Stud				
③92026	92026-7007	1	Spacer				
③92153	92153-7007	3	Bolt				
③92153A	92153-7008	1	Bolt				
③92210	92210-0003	4	Nut				
③130	130B0612	5	Bolt-Flanged				
③130A	130B0616	2	Bolt-Flanged				
③130B	130B0625	2	Bolt-Flanged				
③130C	130B0816	1	Bolt-Flanged				
③311	311B0600	2	Nut-Hex				

Electric Equipment Assembly Kawasaki FH580V AS30

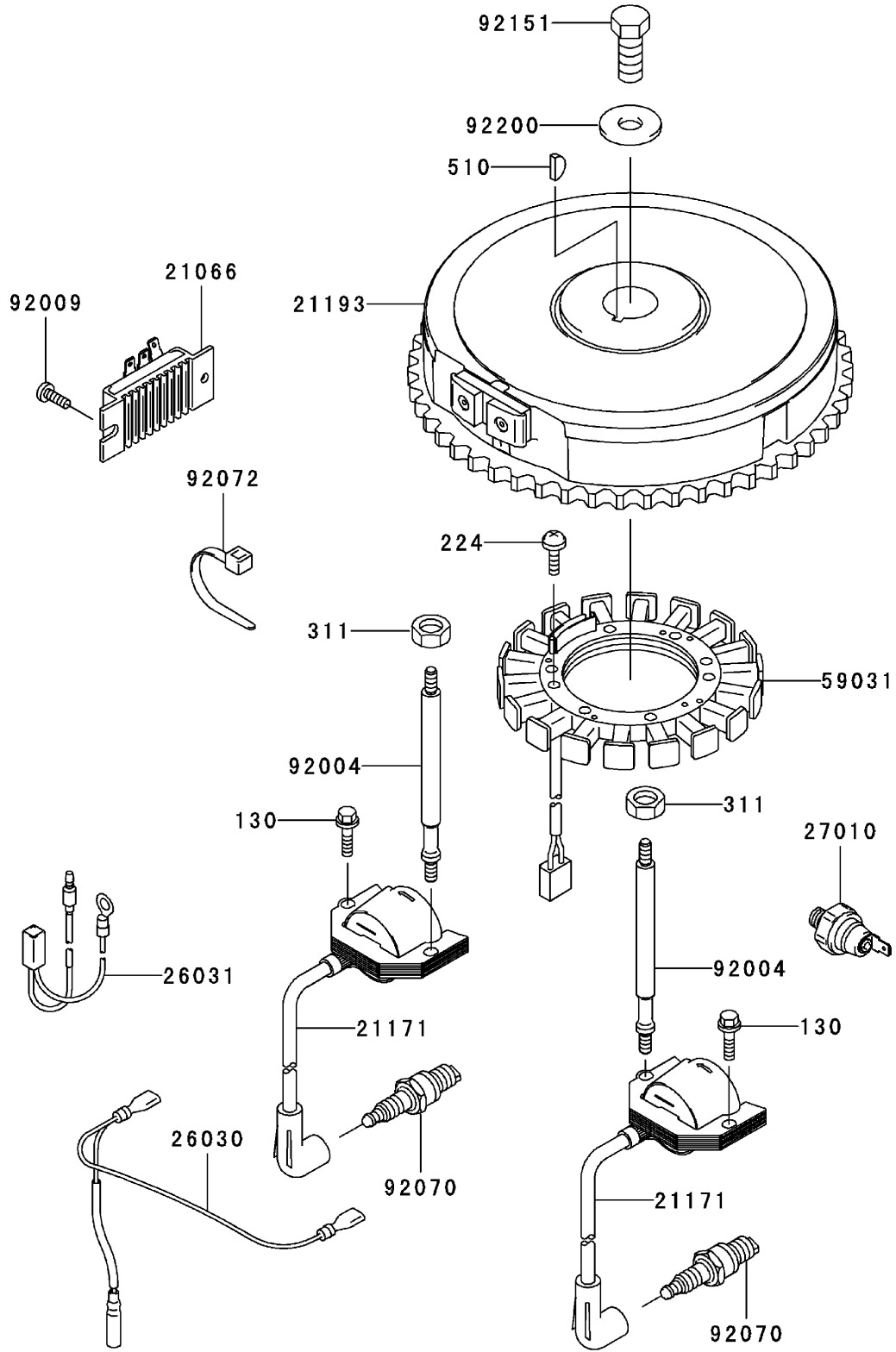

Electric Equipment Assembly Kawasaki FH580V AS30

Ref	Part No.	Qty.	Description				
②1066	21066-7011	1	Regulator-Voltage				
②1171	21171-7013	2	Ignition Coil ASM				
②1193	21193-7007	1	Flywheel ASM				
②6030	26030-7001	1	Harness				
②6031	26031-7002	1	Harness				
②7010	27010-7001	1	Switch				
⑤9031	59031-7001	1	Coil-Charging				
⑨2004	92004-7009	2	Stud				
⑨2009	92009-2308	1	Screw				
⑨2070	92070-7003	2	Plug-Spark (Rcj8y, Solid)				
⑨2072	92072-7003	2	Band				
⑨2151	92151-2097	1	Bolt (12x30)				
⑨2200	92200-7002	1	Washer				
⑨130	130B0620	2	Bolt-Flanged				
⑨224	224B0520	4	Screw-Pan				
⑨311	311B0600	2	Nut-Hex				
⑨510	510A5100	1	Key-Woodruff				

Control Equipment Assembly Kawasaki FH580V AS30

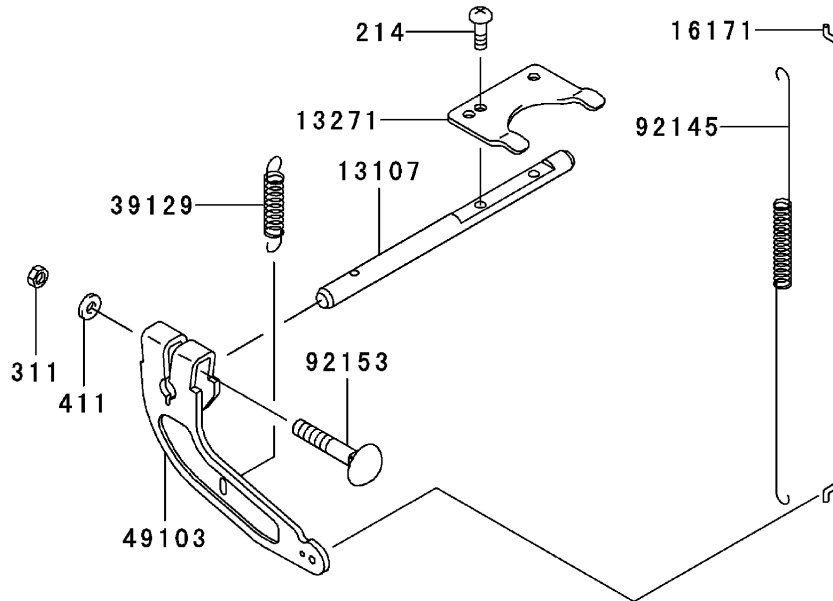
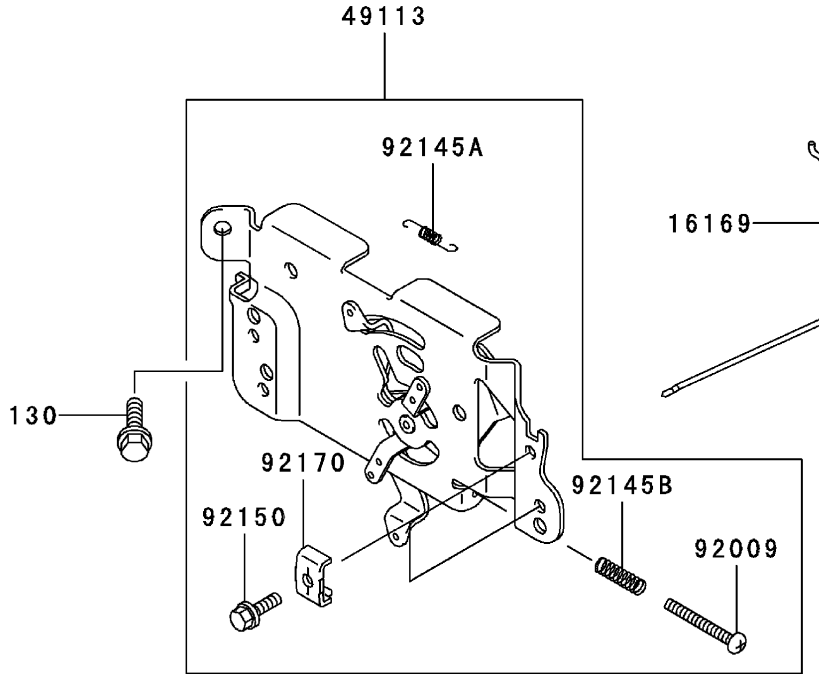

Control Equipment Assembly Kawasaki FH580V AS30

Ref	Part No.	Qty.	Description				
⑤13107	13107-7010	1	Shaft				
⑤13271	13271-7018	1	Plate				
⑤16169	16169-7010	1	Link-Choke				
⑤16171	16171-7001	1	Link				
⑤39129	39129-7003	1	Spring-Governor				
⑤49103	49103-7004	1	Arm-Governor				
⑤49113	49113-7011	1	Panel-Control				
⑤92009	92009-7007	1	Screw (4x35)				
⑤92145	92145-7003	1	Spring				
⑤92145A	92145-7004	1	Spring				
⑤92145B	92145-7005	1	Spring				
⑤92150	92150-2182	2	Bolt (5x18)				
⑤92153	92153-7033	1	Bolt (6x35)				
⑤92170	92170-7001	2	Clamp				
⑤130	130B0612	2	Bolt-Flanged				
⑤214	214B0408	2	Screw-Pan				
⑤311	311B0600	1	Nut-Hex				
⑤411	411b0600	1	Washer-Plain				

Carburetor Assembly Kawasaki FH580V AS30

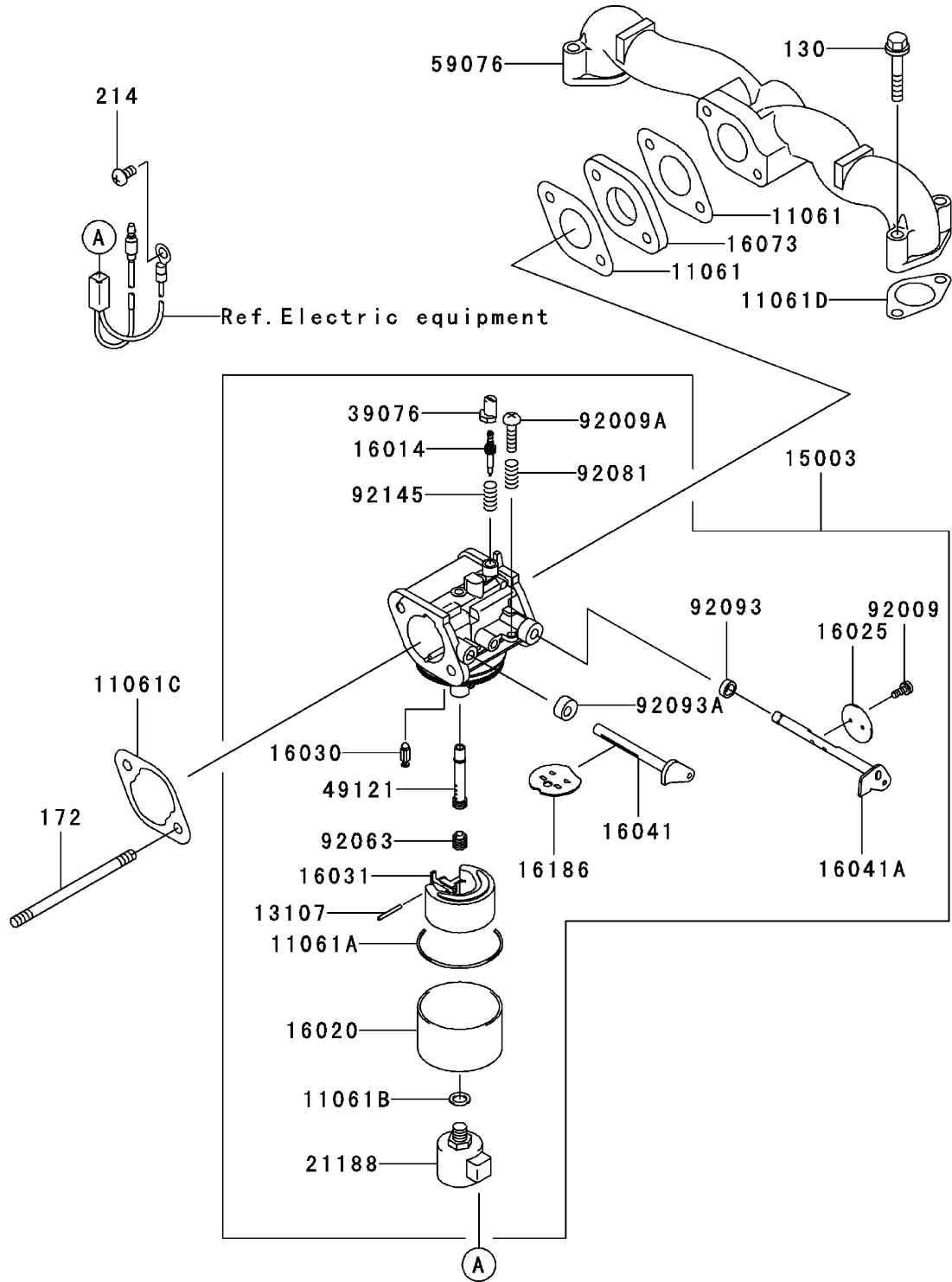

Carburetor Assembly Kawasaki FH580V AS30

Ref	Part No.	Qty.	Description				
⑨11061	11061-7004	2	Gasket-Insulator				
⑨11061A	11061-7009	1	Gasket-Chamber				
⑨11061B	11061-7010	1	Gasket-Screw				
⑨11061C	11061-7018	1	Gasket-Cleaner, Air				
⑨11061D	11061-7019	2	Gasket				
⑨13107	13107-7018	1	Shaft				
⑨15003	15003-7100	1	Carburetor ASM				
⑨16014	16014-7007	1	Screw-Air, Pilot				
⑨16020	16020-7003	1	Chamber-Float				
⑨16025	16025-7006	1	Valve-Throttle				
⑨16030	16030-7003	1	Valve-Float				
⑨16031	16031-7002	1	Float				
⑨16041	16041-7016	1	Shaft-Carburetor, Choke				
⑨16041A	16041-7018	1	Shaft-Carburetor, Throttle				
⑨16073	16073-7007	1	Insulator				
⑨16186	16186-7004	1	Choke Valve ASM				
⑨21188	21188-7002	1	Solenoid				
⑨39076	39076-7001	1	Limiter				
⑨49121	49121-7004	1	Nozzle-Main				
⑨59076	59076-7001	1	Manifold-Intake				
⑨92009	92009-2083	2	Screw				
⑨92009A	92009-2349	1	Screw				
⑨92063	92063-7062	1	Jet-Main, No. 110				
⑨92081	92081-2234	1	Spring				
⑨92093	92093-2100	1	Seal				
⑨92093A	92093-7003	1	Seal				
⑨92145	92145-7015	1	Spring				
⑨130	130B0635	4	Bolt-Flanged				
⑨172	172G0690	2	Bolt-Stud				
⑨214	214B0510	1	Screw-Pan				

Air-Filter/Muffler Assembly Kawasaki FH580V AS30

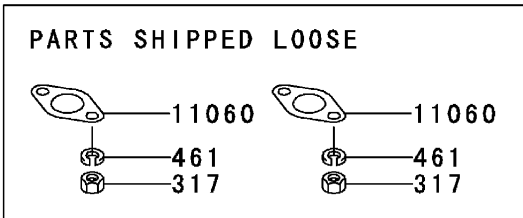
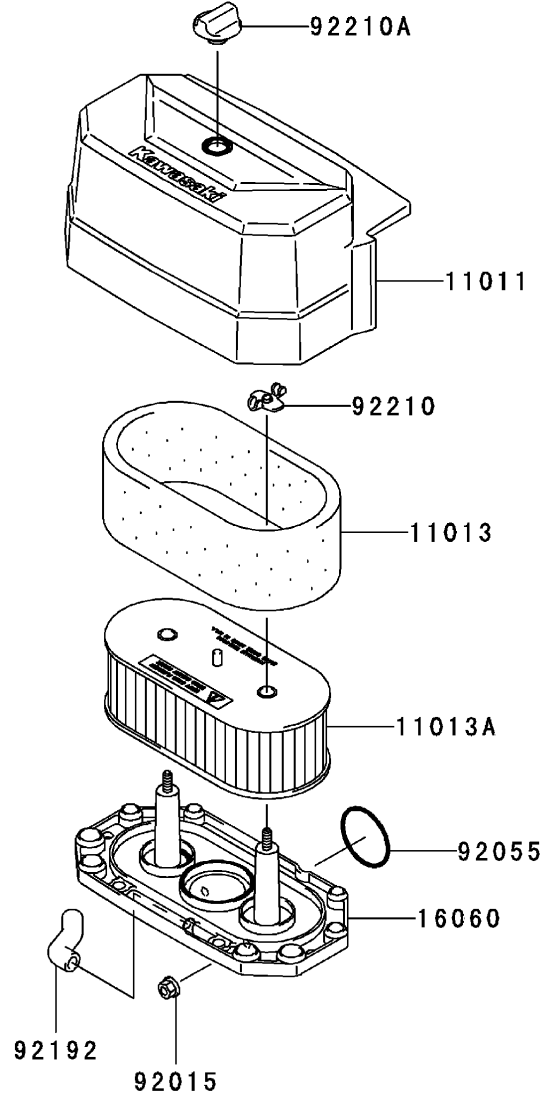

Air-Filter/Muffler Assembly Kawasaki FH580V AS30

Ref	Part No.	Qty.	Description				
①11011	11011-7036	1	Case-Filter, Air				
①11013	11013-7025	1	Element-Filter, Air				
①11013A	11013-7031	1	Element-Filter, Air				
①11060	11060-7021	2	Gasket-Muffler				
①16060	16060-7016	1	Pipe-Intake				
①92015	92015-1193	2	Nut				
①92055	92055-7015	1	O-Ring				
①92192	92192-7010	1	Tube				
①92210	92210-7004	2	Nut				
①92210A	92210-7019	1	Nut				
①317	317R0800	4	Nut-Hex, Small				
①461	461F0800	4	Washer-Spring				

Starter Assembly Kawasaki FH580V AS30

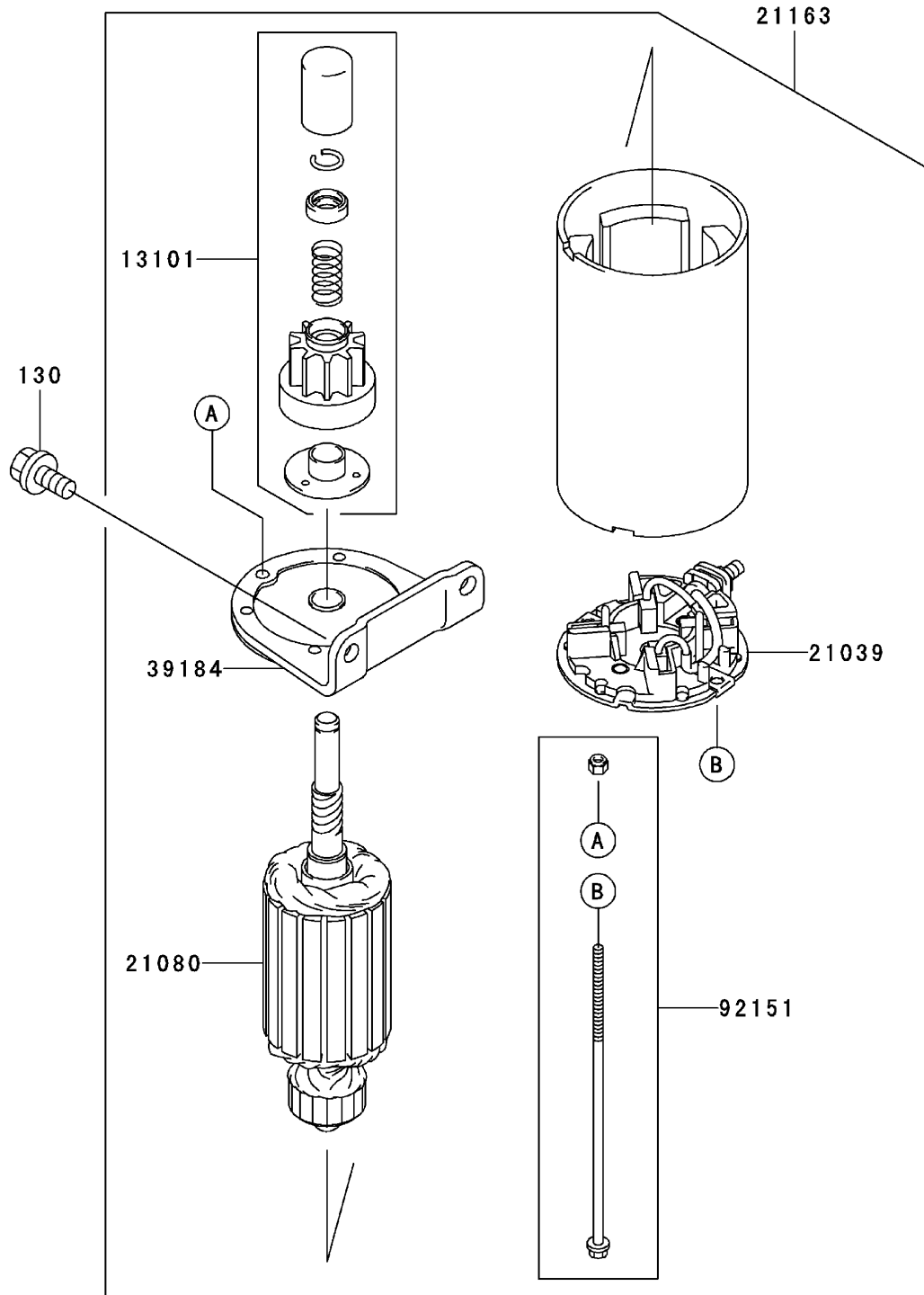

Starter Assembly Kawasaki FH580V AS30

Ref	Part No.	Qty.	Description				
①13101	13101-7003	1	Gear ASM				
①21039	21039-7004	1	Brush				
①21080	21080-7001	1	Armature				
①21163	21163-7010	1	Starter-Electric				
①39184	39184-7004	1	Bracket ASM				
①92151	92151-7013	1	Bolt				
①130	130B0816	2	Bolt-Flanged				

56033

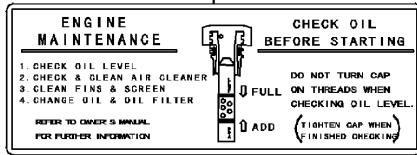

56070



56080

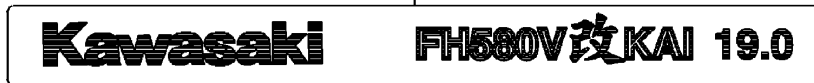

**Label Assembly
Kawasaki FH580V AS30**

Ref	Part No.	Qty.	Description
56033	56033-7002	1	Label-Manual
56070	56070-7001	1	Label-Warning
56080	56080-7022	1	Label-Brand

NOTES

NOTES

NOTES

