



Count on it.

Operator's Manual

420 and 430 Garden Tractor

Model No. 72211—Serial No. 250000001 and Up

Model No. 72212—Serial No. 250000001 and Up

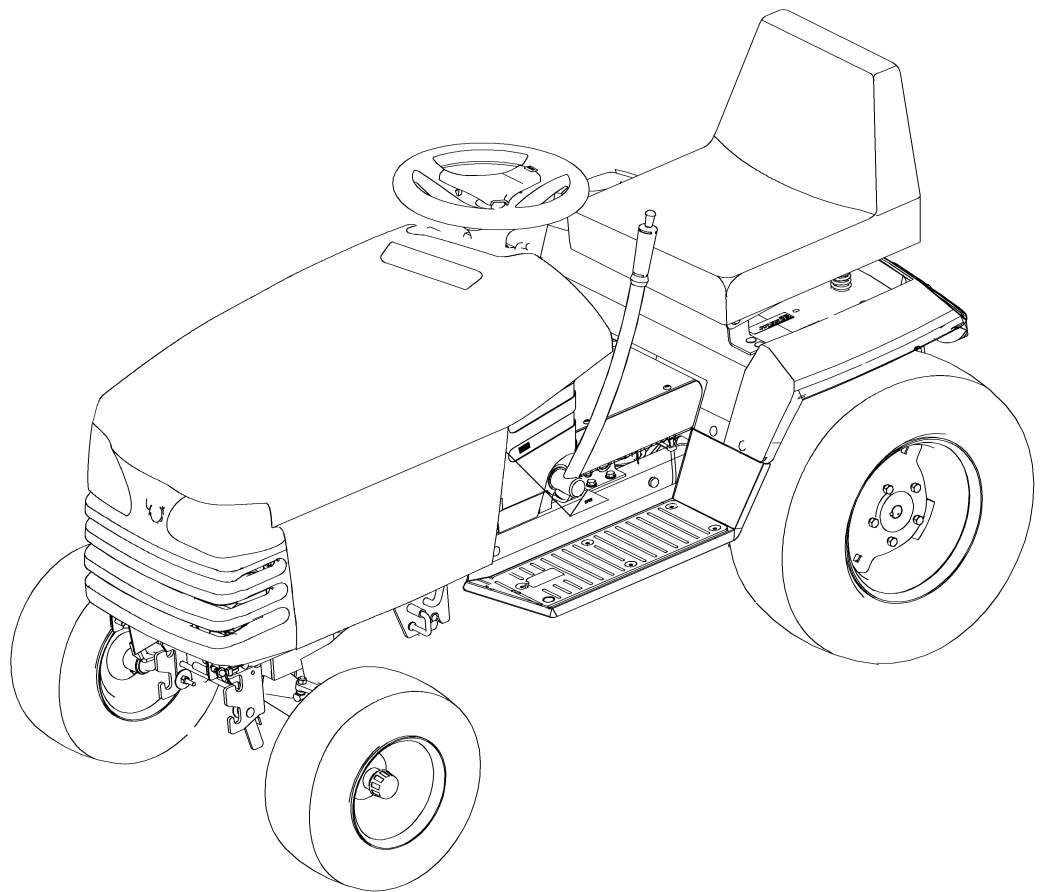

This spark ignition system complies with Canadian ICES-002

Contents

- Introduction 2
- Safety 4
 - Safe Operating Practices..... 4
 - Toro Riding Mower Safety 5
 - Slope Chart 6
 - Safety and Instructional Decals 7
- Setup 10
 - 1 Installing the Steering Wheel 11
 - 2 Installing the Seat..... 11
 - 3 Activating and Installing the Battery 12
 - 4 Installing the Front Tires..... 13
 - 5 Installing the Rear Wheels 13
 - 6 Checking the Tire Pressure and Tractor Lubrication..... 14
 - 7 Reading the Manual and Viewing the Safety Video 14
 - 8 Checking the Safety System 14
 - 9 Test Drive the Tractor 14
- Product Overview 16
 - Controls 17
- Operation 19
 - Recommended Gasoline 19
 - Check Engine Oil Level..... 20
 - Think Safety First..... 20
 - Operating the Parking Brake 20
 - Starting and Stopping the Engine..... 20
 - Operating the Power Take Off (PTO)..... 21
 - The Safety Interlock System..... 21
 - Driving Forward or Backward 23
 - Stopping the Machine 23
 - Operating the Attachment Lift Lever 24
 - Using the Attachment Power Lift..... 24
 - Positioning the Seat 24
 - Using the Headlights 25
 - Positioning the Tilt Steering Wheel 25
 - Pushing the Machine by Hand..... 25
 - Using the Cruise Control..... 26
- Maintenance 27
 - Recommended Maintenance Schedule(s) 27
 - Lubrication 27
 - Greasing and Lubrication 27
 - Engine Maintenance 28
 - Servicing the Engine Oil..... 28
 - Servicing the Air Cleaner 29

- Servicing the Spark Plug..... 30
- Fuel System Maintenance 31
 - Draining The Fuel Tank 31
 - Servicing the Fuel Filter 31
- Electrical System Maintenance 32
 - Servicing the Fuses..... 32
 - Servicing the Headlights..... 32
 - Servicing the Battery..... 33
- Drive System Maintenance 36
 - Checking the Tire Pressure 36
 - Servicing the Front Wheel Toe-In 36
 - Transaxle Fluid 36
- Cooling System Maintenance 37
 - Cleaning the Cooling System..... 37
- Brake Maintenance 37
 - Servicing the Brake..... 37
- Storage 38
 - Cleaning and Storage 38
- Troubleshooting 39
- Schematics 41

Introduction

Read this information carefully to learn how to operate and maintain your product properly and to avoid injury and product damage. You are responsible for operating the product properly and safely.

You may contact Toro directly at www.Toro.com for product and accessory information, help finding a dealer, or to register your product.

Whenever you need service, genuine Toro parts, or additional information, contact an Authorized Service Dealer or Toro Customer Service and have the model and serial numbers of your product ready. Figure 1 identifies the location of the model and serial numbers on the product. Write the numbers in the space provided.

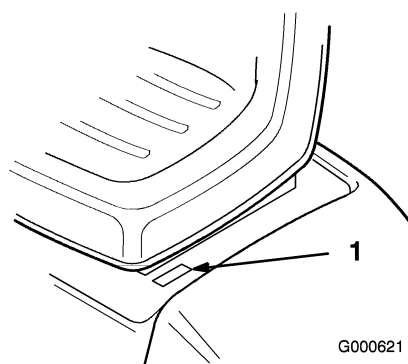

Figure 1

1. Model and serial number plate

Model No. _____

Serial No. _____

This manual identifies potential hazards and has safety messages identified by the safety alert symbol (Figure 2), which signals a hazard that may cause serious injury or death if you do not follow the recommended precautions.



Figure 2

1. Safety alert symbol.

This manual uses two other words to highlight information. **Important** calls attention to special mechanical information and **Note** emphasizes general information worthy of special attention.

Safety

This machine meets or exceeds the B71.1-1998 specifications of the American National Standards Institute, in effect at the time of production. However, improper use or maintenance by the operator or owner can result in injury. To reduce the potential for injury, comply with these safety instructions and always pay attention to the safety alert symbol, which means CAUTION, WARNING, or DANGER—"personal safety instruction." Failure to comply with the instruction may result in personal injury or death.

Safe Operating Practices

The following instructions are from ANSI standard B71.1-1998.

This product is capable of amputating hands and feet and throwing objects. Always follow all safety instructions to avoid serious injury or death.

General Operation

- Read, understand, and follow all instructions in the operator's manual and on the machine before starting.
- Allow only responsible adults who are familiar with the instructions to operate the machine.
- Clear the area of objects such as rocks, toys, wire, etc., which could be picked up and thrown by the blade.
- Be sure the area is clear of other people before mowing. Stop the machine if anyone enters the area.
- Never carry passengers.
- Do not mow in reverse unless absolutely necessary. Always look down and behind before and while backing.
- Be aware of the mower discharge direction and do not point it at anyone. Do not operate the mower without either the entire grass catcher or the guard in place.
- Slow down before turning.
- Never leave a running machine unattended. Always turn off blades, set parking brake, stop engine, and remove keys before dismounting.
- Turn off blades when not mowing.
- Stop the engine before removing the grass catcher or unclogging the chute.
- Mow only in daylight or good artificial light.
- Do not operate the machine while under the influence of alcohol or drugs.

- Watch for traffic when operating near or crossing roadways.
- Use extra care when loading or unloading the machine into a trailer or truck.
- Always wear safety goggles or safety glasses with side shields when operating mower.
- Data indicates that operators, age 60 years and above, are involved in a large percentage of riding mower-related injuries. These operators should evaluate their ability to operate the riding mower safely enough to protect themselves and others from serious injury.

Slope Operation

Slopes are a major factor related to loss-of-control and tip-over accidents, which can result in severe injury or death. All slopes require extra caution. If you cannot back up the slope or if you feel uneasy on it, do not mow it.

- Mow up and down slopes, not across.
- Remove obstacles such as rocks, tree limbs, etc.
- Watch for holes, ruts or bumps. Uneven terrain could overturn the machine. Tall grass can hide obstacles.
- Use slow speed. Choose a low gear so that you will not have to stop or shift while on the slope.
- Follow Toro's recommendations for wheel weight or counterweights to improve stability.
- Use extra care with grass catchers or other attachments. These can change the stability of the machine.
- Keep all movement on slopes slow and gradual. Do not make sudden changes in speed or direction.
- Avoid starting or stopping on a slope. If tires lose traction, disengage the blades and proceed slowly straight down the slope.
- Do not turn on slopes unless necessary, and then, turn slowly and gradually downhill, if possible.
- Do not mow near drop-offs, ditches, or embankments. The machine could suddenly turn over if a wheel goes over the edge of a cliff or ditch, or if an edge caves in.
- Do not mow on wet grass. Reduced traction could cause sliding.
- Do not try to stabilize the machine by putting your foot on the ground.
- Do not use a grass catcher on steep slopes.

Children

Tragic accidents can occur if the operator is not alert to the presence of children. Children are often attracted

to the machine and the mowing activity. Never assume that children will remain where you last saw them.

- Keep children out of the mowing area and under the watchful care of another responsible adult.
- Be alert and turn the machine off if children enter the area.
- Before and while backing, look behind and down for small children.
- Never carry children, even with the blades off. They may fall off and be seriously injured or interfere with safe machine operation.
- Never allow children to operate the machine.
- Use extra care when approaching blind corners, shrubs, trees, the end of a fence or other objects that may obscure vision.

Service

- Use extra care when handling gasoline and other fuels. They are flammable and vapors are explosive.
 - Use only an approved container.
 - Never remove the gas cap or add fuel when the engine is running. Allow the engine to cool before refueling. Do not smoke.
 - Never refuel the machine indoors.
 - Never store the machine or fuel container inside where there is an open flame, such as near a water heater or furnace.
- Never run a machine inside a closed area.
- Keep nuts and bolts tight, especially the blade attachment bolts. Keep equipment in good condition.
- Never tamper with safety devices. Check their proper operation regularly.
- Keep the machine free of grass, leaves, or other debris build-up. Clean up oil or fuel spillage. Allow the machine to cool before storing.
- Stop and inspect the equipment if you strike an object. Repair, if necessary, before restarting.
- Grass catcher components are subject to wear, damage and deterioration, which could expose moving parts or allow objects to be thrown. Frequently check components and replace with manufacturer's recommended parts, when necessary.
- Mower blades are sharp and can cut. Wrap the blade(s) or wear gloves, and use extra caution when servicing them.
- Use only genuine Toro replacement parts to ensure that original standards are maintained.

Toro Riding Mower Safety

The following list contains safety information specific to Toro products or other safety information that you must know that is not included in the ANSI standards.



Engine exhaust contains carbon monoxide, which is an odorless, deadly poison that can kill you. It is also known to the State of California to cause birth defects.

Do not run engine indoors or in an enclosed area.

- Stop the engine, disconnect spark plug wire(s) and remove key before performing any service, repairs, maintenance or adjustments.
- Slow down before turning. Sharp turns on any terrain may cause loss of control.
- Never leave a running machine unattended. Always turn off blades, set parking brake, stop engine, and remove the ignition and KeyChoice® keys before dismounting.
- Keep hands, feet, hair and loose clothing away from attachment discharge area, underside of mower and any moving parts while engine is running.
- Do not touch equipment or attachment parts which may be hot from operation. Allow to cool before attempting to maintain, adjust or service.
- Battery acid is poisonous and can cause burns. Avoid contact with skin, eyes and clothing. Protect your face, eyes and clothing when working with a battery.
- Battery gases can explode. Keep cigarettes, sparks and flames away from battery.
- Use only genuine replacement parts to ensure that original standards are maintained.
- Use only Toro approved attachments. Warranty may be voided if used with unapproved attachments.
- Do not mow across slopes greater than 5 degrees.
- Do not mow down slopes greater than 15 degrees.
- Do not mow up slopes greater than 10 degrees.
- If a steep slope must be ascended, back up the hill, and drive forward down the hill, keeping the machine in gear.
- Avoid turning on slopes. If you must turn, turn slowly and gradually downhill, if possible.
- Do not use a grass catcher on steep slopes. Heavy grass bags could cause loss of control or overturn the machine.

Slope Chart

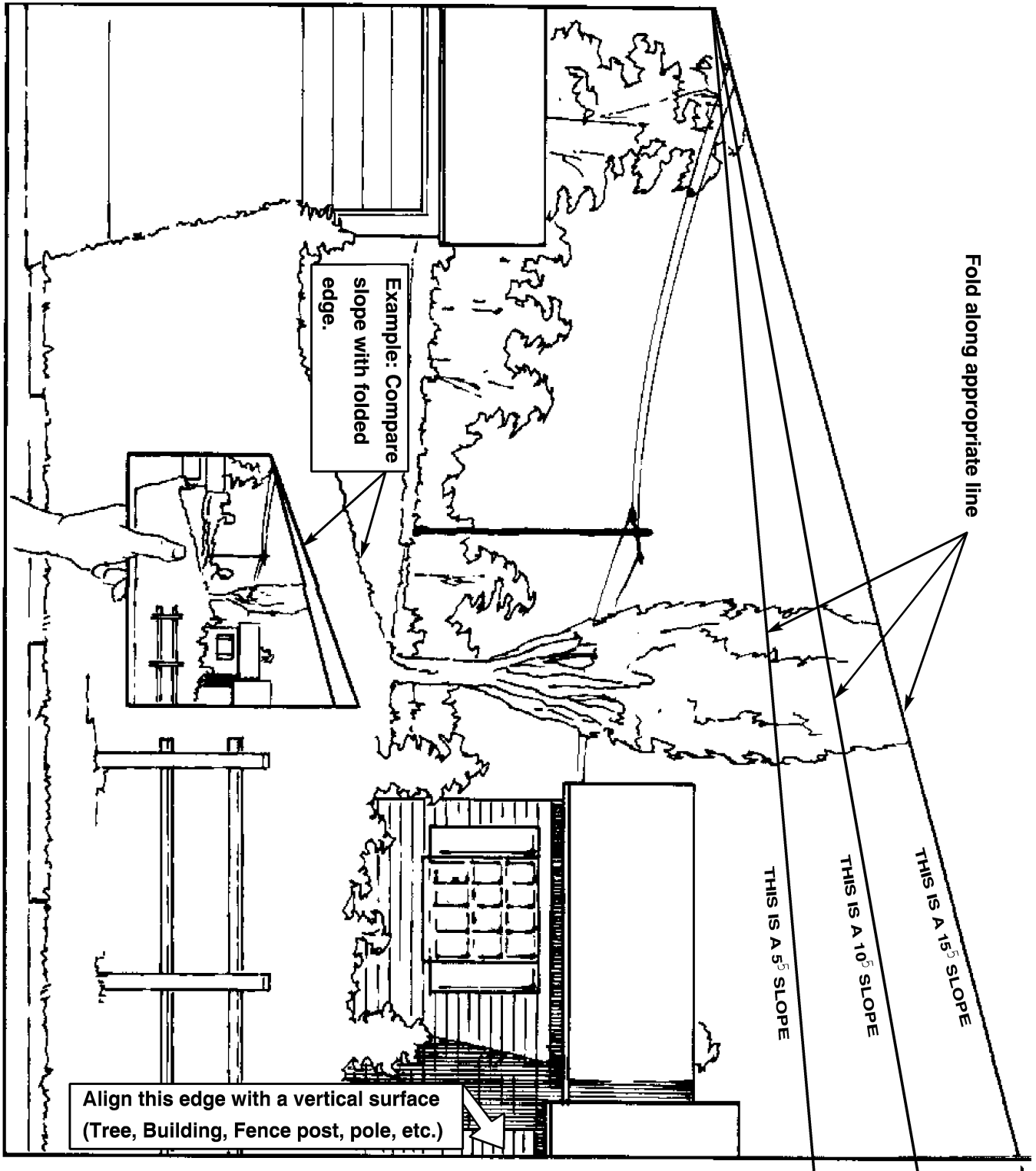

Safety and Instructional Decals



Safety decals and instructions are easily visible to the operator and are located near any area of potential danger. Replace any decal that is damaged or lost.

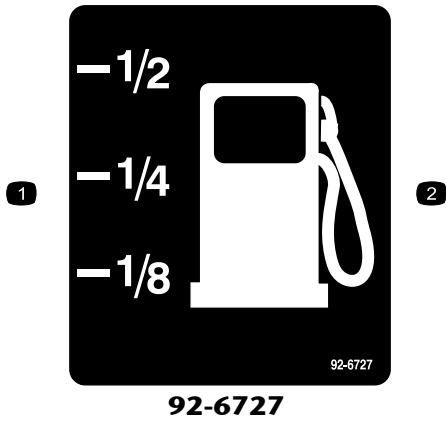

- 1. Fuel levels
- 2. Fuel



- 1. Push the lever in to ride on the machine.
- 2. Pull the lever out to push the machine.
- 3. Do not tow the machine the machine.

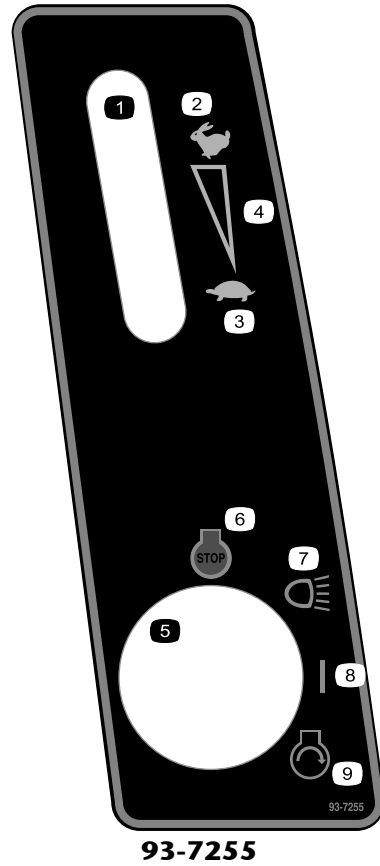

- 1. Throttle
- 2. Fast
- 3. Slow
- 4. Continuous variable setting
- 5. Ignition
- 6. Stop
- 7. Lights
- 8. Run
- 9. Start

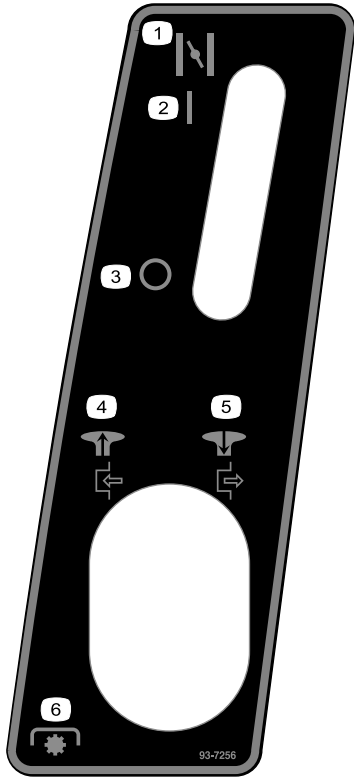

93-7256

- | | |
|----------|------------------------------------|
| 1. Choke | 4. Pull the knob out to start PTO. |
| 2. On | 5. Pull the knob out to stop PTO. |
| 3. Off | 6. PTO |

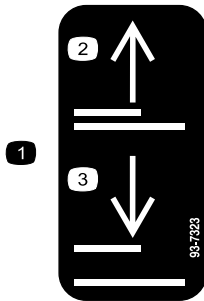

93-7323

- | | |
|---------|---------|
| 1. Lift | 3. Down |
| 2. Up | |

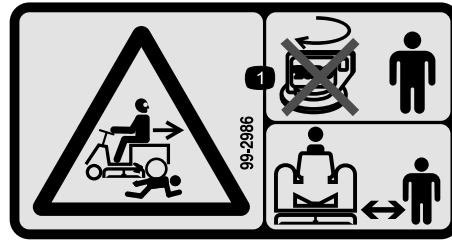

99-2986

1. Crushing/dismemberment hazard of bystanders—do not turn the key while children are present; keep children a safe distance from the machine.



99-5340

1. KeyChoice—turn to enable reverse moving.

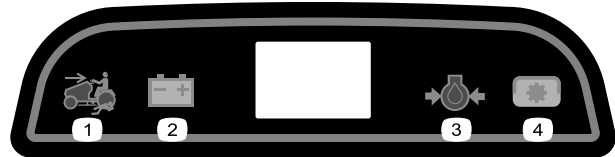

99-8036

Model 420

- | | |
|-------------------------------|-------------------------|
| 1. Mowing in reverse enabled. | 3. Engine oil pressure |
| 2. Battery | 4. Power Take-off (PTO) |

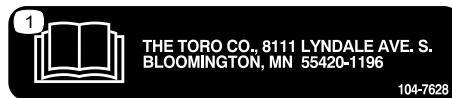

104-7628

1. Read the *Operator's Manual*.

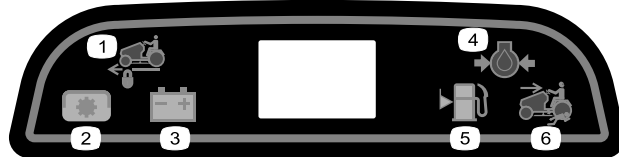

106-9871

Model 430

- | | |
|--------------------------------|-------------------------------|
| 1. Cruise control, locked | 4. Engine oil pressure |
| 2. Power Take-off (PTO) | 5. Fuel level |
| 3. Battery discharge indicator | 6. Mowing in reverse enabled. |



Battery Symbols

Some or all of these symbols are on your battery.

- | | |
|--|--|
| 1. Explosion hazard | 6. Keep bystanders a safe distance from the battery. |
| 2. No fire, open flame, or smoking. | 7. Wear eye protection; explosive gases can cause blindness and other injuries |
| 3. Caustic liquid/chemical burn hazard | 8. Battery acid can cause blindness or severe burns. |
| 4. Wear eye protection | 9. Flush eyes immediately with water and get medical help fast. |
| 5. Read the <i>Operator's Manual</i> . | 10. Contains lead; do not discard. |

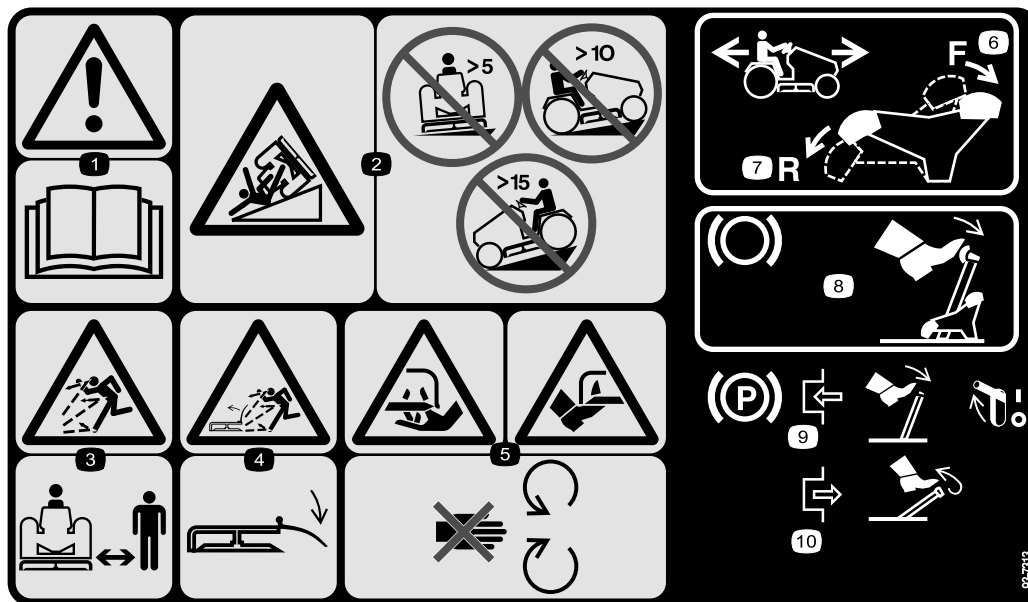

93-7313

- | | | |
|---|---|--|
| 1. Warning—read the <i>Operator's Manual</i> . | 5. Cutting/dismemberment hazard of hand or foot, mower blade—stay away from moving parts. | 9. To engage the parking brake, press the beaked pedal and move the parking brake lever to the On position. To disengage the parking brake, press and release the brake pedal. |
| 2. Tipping hazard—do not drive across slopes greater than 5 degrees, up slopes greater than 10 degrees, or down slopes greater than 15 degrees. | 6. To drive the machine forward, press the 10. ground speed selector forward. | |
| 3. Thrown objects hazard—keep bystanders a safe distance from the machine. | 7. To drive the machine in reverse, press the ground speed selector rearward. | |
| 4. Thrown objects hazard, mower—keep the deflector in place. | 8. To brake, press the brake pedal. | |

Setup

Loose Parts

Use the chart below to verify that all parts have been shipped.

| Step | Description | Qty. | Use |
|------|-------------------------------|------|--|
| 1 | Steering Wheel | 1 | Install the steering wheel. |
| | Lock Washer, 1/2 inch | 1 | |
| | Nut, 1/2 inch | 1 | |
| | Logo Cover | 1 | |
| 2 | Seat | 1 | Install the seat. |
| | Spacer, large inside diameter | 2 | |
| | Spacer, small inside diameter | 2 | |
| | Shoulder bolt | 2 | |
| | Knob | 2 | |
| | Flat washer, 11/32 inch | 2 | |
| 3 | Bolt, 1/4 x 3/4 inch | 2 | Activate and install the battery. |
| | Hex Nut, 1/4 inch | 2 | |
| 4 | Front tires | 2 | Install the front tires. |
| | Cotter pin | 2 | |
| | Shim washers | 4 | |
| | Washers, thick | 2 | |
| | Washers | 2 | |
| | Cap | 2 | |
| 5 | Rear tires | 2 | Install the rear tires. |
| | Lug nuts | 10 | |
| 6 | No parts required | – | Check the Tire Pressure and Tractor Lubrication. |
| 7 | Operator's Manual | 1 | Read the Operator's Manual and watch the video before operating the machine. |
| | Engine Operator's Manual | 1 | |
| | Parts Catalog | 1 | |
| | Safety Video | 1 | |
| | Registration Card | 1 | |
| | Oil drain hose | 1 | |
| 8 | No parts required | – | Check the safety system. |
| 9 | No parts required | – | Test drive the tractor. |

Note: Determine the left and right sides of the machine from the normal operating position.

Step 1

Installing the Steering Wheel

Parts needed for this step:

| | |
|---|-----------------------|
| 1 | Steering Wheel |
| 1 | Lock Washer, 1/2 inch |
| 1 | Nut, 1/2 inch |
| 1 | Logo Cover |

Procedure

1. Position the front wheels straight ahead.
2. Remove the logo cover by releasing the 3 latches from the back side with a screwdriver.
3. Line up the center spoke toward the seat and position the steering wheel onto the shaft spline (Figure 3).

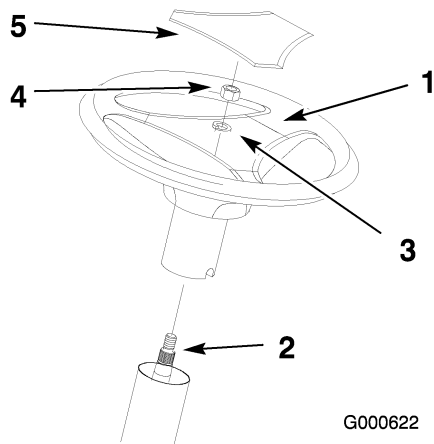

Figure 3

- | | |
|--------------------------|------------------|
| 1. Center spoke | 4. Nut, 1/2 inch |
| 2. Shaft spline | 5. Logo cover |
| 3. Lock washer, 1/2 inch | |

4. Secure the steering wheel with a lockwasher (1/2 inch) and nut (1/2 inch) (Figure 3).
5. Torque the steering wheel nut to 50 ft-lb (37 N.m).
6. Snap the logo cover into place (Figure 3).

Step 2

Installing the Seat

Parts needed for this step:

| | |
|---|-------------------------------|
| 1 | Seat |
| 2 | Spacer, large inside diameter |
| 2 | Spacer, small inside diameter |
| 2 | Shoulder bolt |
| 2 | Knob |
| 2 | Flat washer, 11/32 inch |

Procedure

1. Install the large inside diameter spacer and the 2 shoulder bolts into the rear holes of the seat (Figure 4).

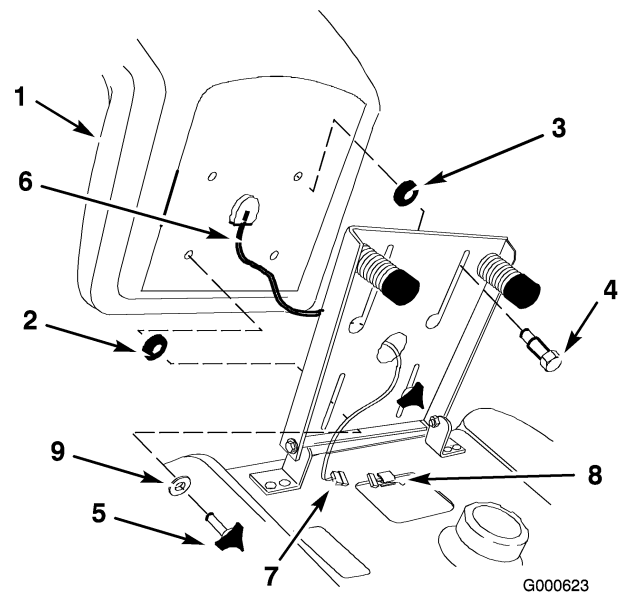

Figure 4

- | | |
|--------------------|----------------------------|
| 1. Seat | 6. Wire and connector |
| 2. Spacer-small ID | 7. Wire harness connector |
| 3. Spacer-large ID | 8. Wire clip |
| 4. Shoulder bolt | 9. Flat washer, 11/32 inch |
| 5. Knob | |

2. Position the seat onto the seat base by inserting the 2 shoulder bolts through the key hole openings at the end of both slots (Figure 4).
3. Locate the small inside diameter spacer between the seat and the seat base, thread the 2 knobs and 2 flat washers (11/32 inch) into the front holes in the seat (Figure 4). Adjust the seat and tighten the knobs.

- Route the seat switch wire and connector through the center opening in the seat base. Push the seat switch connector fully into the wire harness connector (Figure 4).
- Secure the seat switch wire cable to the fender opening (Figure 4).

Step
3

Activating and Installing the Battery

Parts needed for this step:

| | |
|---|----------------------|
| 2 | Bolt, 1/4 x 3/4 inch |
| 2 | Hex Nut, 1/4 inch |

Procedure

Bulk electrolyte with 1.265 specific gravity must be purchased from a local battery supply outlet.



Battery electrolyte contains sulfuric acid which is a deadly poison and causes severe burns.

- Do not drink electrolyte and avoid contact with skin, eyes or clothing. Wear safety glasses to shield your eyes and rubber gloves to protect your hands.
- Fill the battery where clean water is always available for flushing the skin.
- Follow all instructions and comply with all safety messages on the electrolyte container.

- Remove the battery from the tractor.
- Clean the top of the battery with a paper towel.
Note: Never fill the battery with electrolyte while the battery installed in the tractor. Electrolyte could be spilled on other parts and cause corrosion.
- Remove the vent caps from the battery (Figure 5).

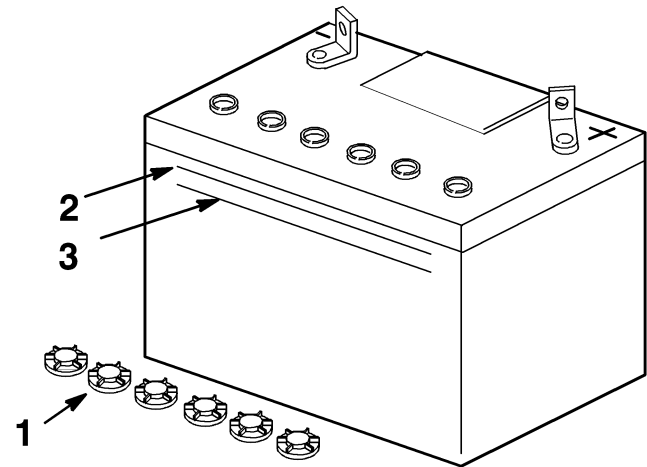

G000624

Figure 5

- Filler caps
- Upper line
- Lower line

- Slowly pour electrolyte into each battery cell until the level is up to the upper line on the battery case (Figure 5).

Important: Do not overfill the battery because electrolyte (sulfuric acid) can cause severe corrosion and damage to the chassis.

- Wait five to ten minutes after filling the battery cells. Add electrolyte, if necessary, until the electrolyte level is up to the upper line on the battery case (Figure 5).
- Install the battery filler caps.



Charging the battery produces gasses that can explode.

Never smoke near the battery and keep sparks and flames away from battery.

Note: Make sure the vent caps are installed in the battery.

- Charge the battery for 1 hour at 10 amps or 2 hours at 5 amps.
- When the battery is fully charged, unplug the charger from the electrical outlet, then disconnect the charger leads from the battery posts (Figure 6).

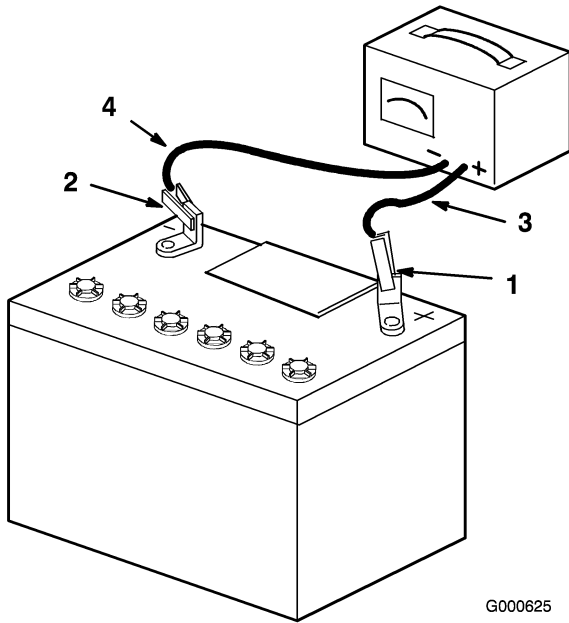

Figure 6

- | | |
|--------------------------|---------------------------|
| 1. Positive Battery Post | 3. Red (+) Charger Lead |
| 2. Negative Battery Post | 4. Black (-) Charger Lead |

9. Install the battery in the tractor and connect the battery cables. Refer to the Installing the Battery in Electrical System Maintenance, page 32 .

Note: Do not run the tractor with the battery disconnected, electrical damage may occur.

Step
4

Installing the Front Tires

Parts needed for this step:

| | |
|---|----------------|
| 2 | Front tires |
| 2 | Cotter pin |
| 4 | Shim washers |
| 2 | Washers, thick |
| 2 | Washers |
| 2 | Cap |

Procedure

1. Remove the tires from the crate (Figure 7).
2. Install a thin washer (3/4 inch) onto the axle (Figure 7).

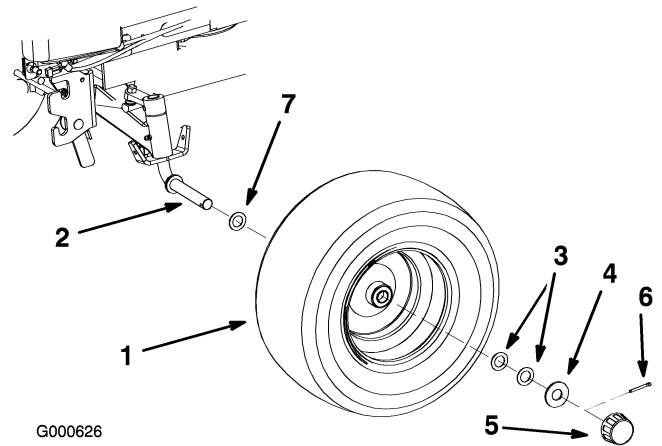

Figure 7

- | | |
|---------------------------|--------------------------|
| 1. Front wheel | 5. Cap |
| 2. Axle | 6. Cotterpin |
| 3. Shim washer | 7. Thin Washer, 3/4 inch |
| 4. Thick washer, 3/4 inch | |

3. Slide wheel onto axle with valve stem in (Figure 7).
4. Wheel end play should be 0 to 0.015 inch (0 to 0.4 mm). Install the shim washers (as required) and thick flat washer (3/4 inch) for spacing on the axle.
5. Insert cotter pin through the axle and bend the ends of the pin open (Figure 7).
6. Push the cap onto the end of the axle so it snaps over washer (Figure 7).
7. Repeat steps 2-6 on opposite side.
8. Grease the wheel bearings.

Step
5

Installing the Rear Wheels

Parts needed for this step:

| | |
|----|------------|
| 2 | Rear tires |
| 10 | Lug nuts |

Procedure

1. Install the rear wheel onto the wheel hub with the valve stem to the inside (Figure 8).
2. Torque the wheel bolts to 75-80 ft-lb (105-112 N m).

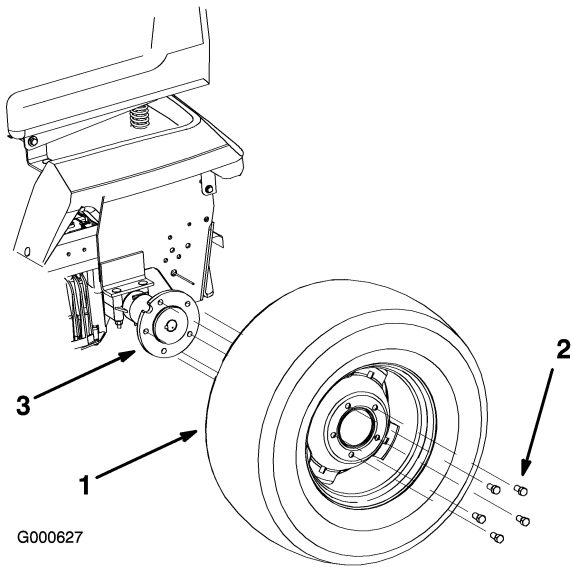

Figure 8

- 1. Rear wheel
- 2. Wheel bolts
- 3. Wheel hub

Refer to Checking the Safety Interlock System in Operation, page 19.

Step 6

Checking the Tire Pressure and Tractor Lubrication

No Parts Required

Procedure

Check the front and rear tire pressure. Refer to Checking the Tire Pressure in the Maintenance Section.

Important: The tractor is shipped from the factory with oil in the engine crank case.

Check the engine oil and add only enough oil to raise the level to the full mark on the dipstick. Refer to Checking the Engine Oil in the Maintenance Section.

Check the tractor to ensure it is lubricated. Refer to Greasing and Lubrication in the Maintenance Section.

Step 7

Reading the Manual and Viewing the Safety Video

Parts needed for this step:

| | |
|---|--------------------------|
| 1 | Operator's Manual |
| 1 | Engine Operator's Manual |
| 1 | Parts Catalog |
| 1 | Safety Video |
| 1 | Registration Card |
| 1 | Oil drain hose |

Procedure

- Read the Operator's Manual.
- Learn how to operate the tractor. Read the Operation section in this manual.
- View the safety video.
- Fill out the registration card.
- Use the oil drain hose when changing the engine oil.

Step 8

Checking the Safety System

No Parts Required

Procedure



If safety interlock switches are disconnected or damaged the machine could operate unexpectedly causing personal injury.

- Do not tamper with the interlock switches.
- Check the operation of the interlock switches daily and replace any damaged switches before operating the machine.

Step 9

Test Drive the Tractor

No Parts Required

Procedure

1. Fill the tank with unleaded regular gasoline; Gasoline and Oil in Operation, page 19. Open the fuel shutoff valve and check the fuel hose and fittings for leaks.
2. As applicable, check and test the operation of the following:
 - Engine, choke and throttle controls
 - Headlights
 - Indicator lights
 - PTO clutch and brake
 - Lift system
 - Parking brake
 - Steering
 - Tractor operation in forward and reverse

Product Overview

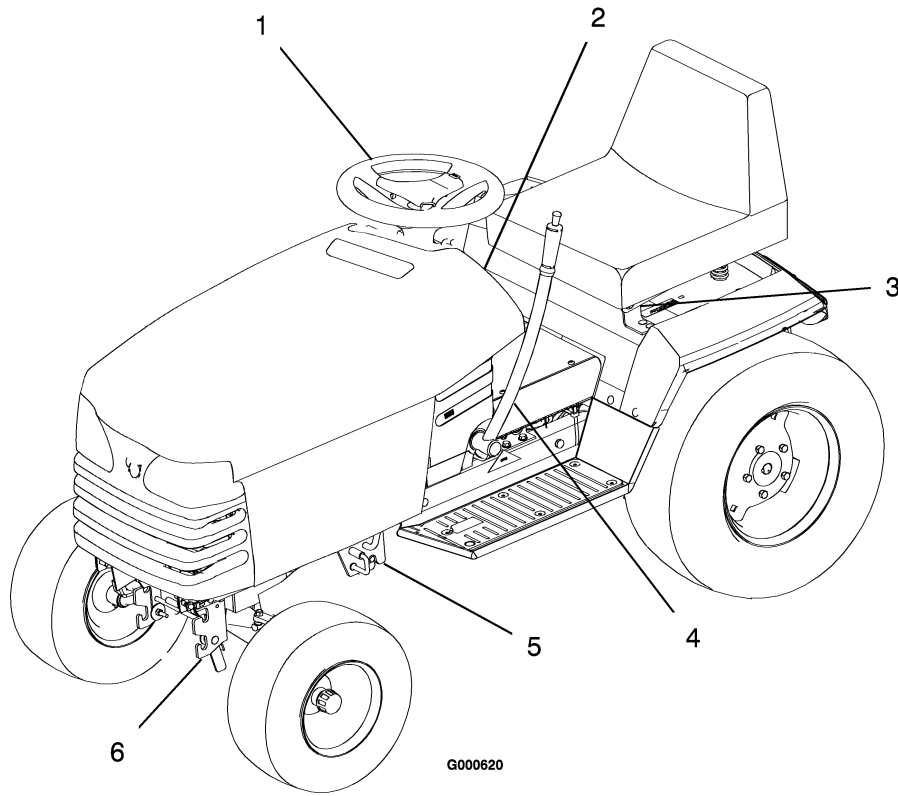

Figure 9

- | | | | |
|------------------------|--------------------------|---|---------------------|
| 1. Steering wheel | 5. Ground speed selector | 9. Cruise control switch | 13. Attachment lift |
| 2. Ignition switch | 6. Throttle lever | 10. Indicator control module/Hourmeter | |
| 3. Brake pedal | 7. Choke lever | 11. Tilt wheel lever | |
| 4. Parking brake lever | 8. Power take off (PTO) | 12. Hood opening | |

Controls

Become familiar with all the controls (Figure 10 for model 420 or Figure 11 for model 430) before you start the engine and operate the machine.

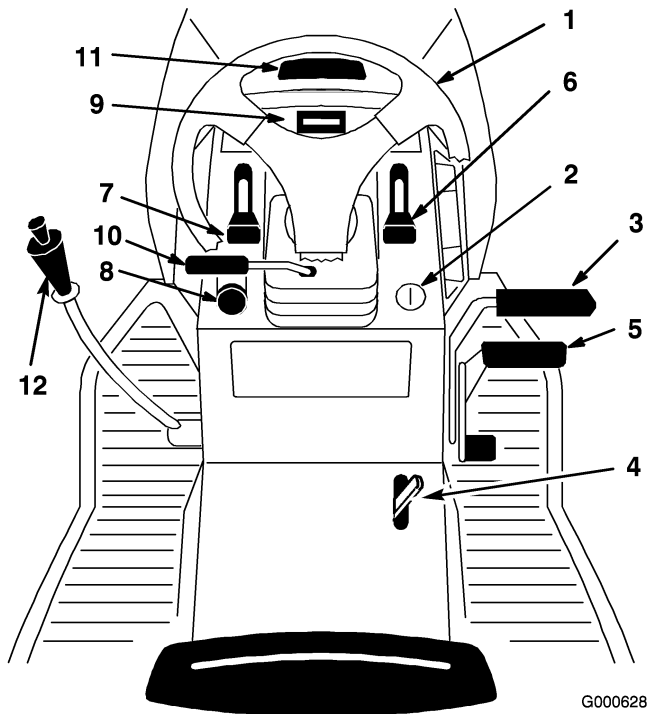

Figure 10
Model 420

- | | |
|--------------------------|--|
| 1. Steering wheel | 8. Power take off (PTO) |
| 2. Ignition switch | 9. Cruise control switch |
| 3. Brake pedal | 10. Indicator control module/Hourmeter |
| 4. Parking brake lever | 11. Tilt wheel lever |
| 5. Ground speed selector | 12. Hood opening |
| 6. Throttle lever | 13. Attachment lift |
| 7. Choke lever | |

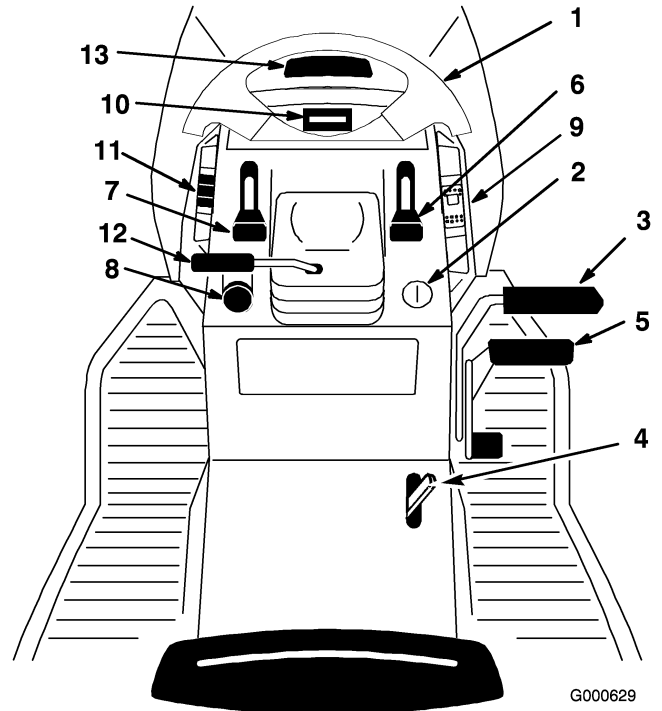

Figure 11
Model 430

- | | |
|--------------------------|--|
| 1. Steering wheel | 8. Power take off (PTO) |
| 2. Ignition switch | 9. Cruise control switch |
| 3. Brake pedal | 10. Indicator control module/Hourmeter |
| 4. Parking brake lever | 11. Attachment lift switch |
| 5. Ground speed selector | 12. Tilt wheel lever |
| 6. Throttle lever | 13. Hood opening |
| 7. Choke lever | |

Indicator Control Module

The indicator control module (Figure 12 and Figure 13) contains lights for:

- Operating in reverse
- Power take off (PTO)
- Battery
- Oil pressure
- Hourmeter (LED)
- Cruise control (Model 430 only)
- Fuel level (Model 430 only)

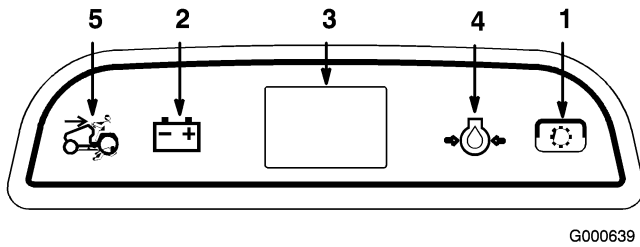

Figure 12

- | | |
|-------------------------|-------------------------|
| 1. Power take off (PTO) | 4. Oil pressure |
| 2. Battery | 5. Operating-in-Reverse |
| 3. Hourmeter | |

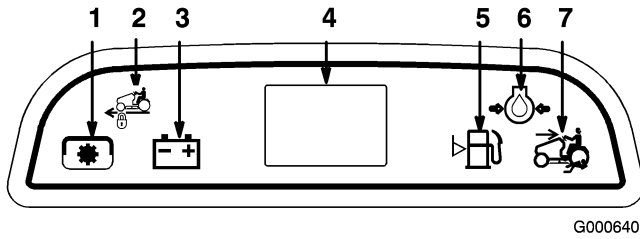

Figure 13

- | | |
|-------------------------|-------------------------|
| 1. Power take off (PTO) | 5. Fuel level |
| 2. Cruise control | 6. Oil Pressure |
| 3. Battery | 7. Operating-in-Reverse |
| 4. Hourmeter | |

Following are the conditions when indicator lights will be on. At other times the lights should be off.

- **Battery**

The battery light will be on when the ignition key is in the run or lights positions if the battery voltage is below 11.2 volts. When this light comes on it is important to have your battery and electrical system checked and the problem corrected.

- **Fuel Level**

The fuel level light will be on when the ignition key is in the run or lights positions and the fuel level is low, approximately one pint remaining.

- **Oil**

The oil light will be on when the ignition key is in the run or lights positions and the engine is not running, after the engine is started the light should go out. When the engine is running if the oil pressure drops below a safe operating level the light comes on. When the light comes on while the engine is running, Stop engine immediately and correct the cause of low oil pressure.

- **PTO (Power Take Off)**

The PTO (power take off) light will be on when the ignition key is in the run or lights positions and the PTO (power take off) is engaged on. When this

light is on it is a reminder; the starter will not crank and turn off the PTO before getting off.

- **Hourmeter**

The hourmeter records the number of hours the engine has operated. It is turned on when the ignition switch is in the run or lights positions. Use the times for scheduling regular maintenance.

Operation

Recommended Gasoline

Use UNLEADED Regular Gasoline suitable for automotive use (85 pump octane minimum). Leaded regular gasoline may be used if unleaded regular is not available.

Important: Never use methanol, gasoline containing methanol, or gasohol containing more than 10% ethanol because the fuel system could be damaged. Do not mix oil with gasoline.



Gasoline is harmful or fatal if swallowed. Long-term exposure to vapors can cause serious injury and illness.

- Avoid prolonged breathing of vapors.
- Keep face away from nozzle and gas tank or conditioner opening.
- Keep gas away from eyes and skin.



In certain conditions, gasoline is extremely flammable and highly explosive. A fire or explosion from gasoline can burn you and others and can damage property.

- Fill the fuel tank outdoors, in an open area, when the engine is cold. Wipe up any gasoline that spills.
- Never fill the fuel tank inside an enclosed trailer.
- Do not fill the fuel tank completely full. Add gasoline to the fuel tank until the level is 1/4 to 1/2 inch (6 to 13 mm) below the bottom of the filler neck. This empty space in the tank allows gasoline to expand.
- Never smoke when handling gasoline, and stay away from an open flame or where gasoline fumes may be ignited by a spark.
- Store gasoline in an approved container and keep it out of the reach of children. Never buy more than a 30 day supply of gasoline.
- Always place gasoline containers on the ground away from your vehicle before filling.
- Do not fill gasoline containers inside a vehicle or on a truck or trailer bed because interior carpets or plastic truck bed liners may insulate the container and slow the loss of any static charge.
- When practical, remove gas-powered equipment from the truck or trailer and refuel the equipment with its wheels on the ground.
- If this is not possible, then refuel such equipment on a truck or trailer from a portable container, rather than from a gasoline dispenser nozzle.
- If a gasoline dispenser nozzle must be used, keep the nozzle in contact with the rim of the fuel tank or container opening at all times until fueling is complete.

Using Stabilizer/Conditioner

Use a fuel stabilizer/conditioner in the machine to provide the following benefits:

- Keeps gasoline fresh during storage of 90 days or less. For longer storage it is recommended that the fuel tank be drained.

- Cleans the engine while it runs
- Eliminates gum-like varnish buildup in the fuel system, which causes hard starting

Important: Do not use fuel additives containing methanol or ethanol.

Add the correct amount of gas stabilizer/conditioner to the gas.

Note: A fuel stabilizer/conditioner is most effective when mixed with fresh gasoline. To minimize the chance of varnish deposits in the fuel system, use fuel stabilizer at all times.

Filling the Fuel Tank

1. Shut the engine off and set the parking brake.
2. Clean around fuel tank cap and remove the cap. Add unleaded regular gasoline to fuel tank, until the level is 1/4 to 1/2 inch (6 to 13 mm) below the bottom of the filler neck. This space in the tank allows gasoline to expand. Do not fill the fuel tank completely full.
3. Install fuel tank cap securely. Wipe up any gasoline that may have spilled.

Check Engine Oil Level

Before you start the engine and use the machine, check the oil level in the engine crankcase; refer to Checking the Engine Oil Level in Engine Maintenance, page 28 .

Think Safety First

Please carefully read all the safety instructions. Knowing this information could help you, your family, pets or bystanders avoid injury.

Operating the Parking Brake

Always set the parking brake when you stop the machine or leave it unattended.

Setting the Parking Brake

1. Push the brake pedal (Figure 14) down and hold it in the depressed position.

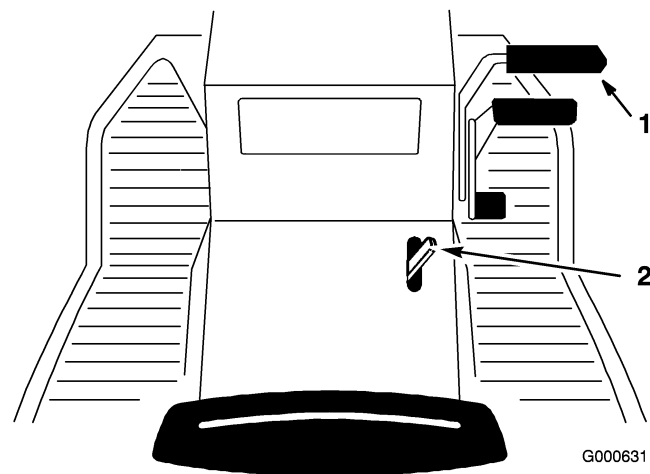

Figure 14

1. Brake pedal
2. Parking brake lever

2. Lift the parking brake lever (Figure 14) forward and gradually take your foot off the brake pedal. The brake pedal should stay in the depressed (locked) position.

Releasing the Parking Brake

1. Push down on the brake pedal (Figure 14). The parking brake lever should release.
2. Gradually release the brake pedal.

Starting and Stopping the Engine

Starting the Engine

1. Sit down on the seat.
2. Set the parking brake; refer to Setting the Parking Brake in Brake Maintenance, page 37.

Note: The engine will not start unless you set the parking brake or fully depress the brake pedal.

3. Push the PTO (power take off) to the off position (Figure 15).
4. Move the choke lever to the on position (Figure 15).

Note: An engine that has been running and is warm may not require step 4.

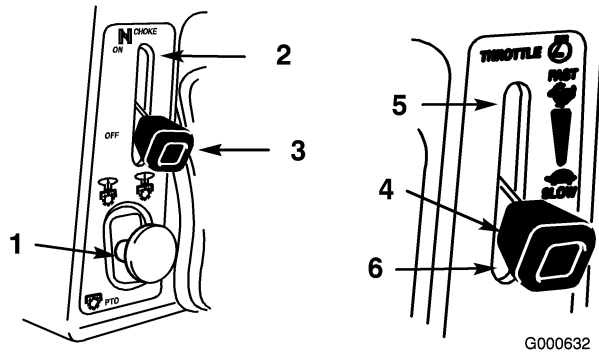

Figure 15

- | | |
|--------------|-------------------|
| 1. PTO-Off | 4. Throttle lever |
| 2. Choke-On | 5. Fast |
| 3. Choke-Off | 6. Slow |

5. Move throttle lever to the fast position (Figure 15).
6. Turn the ignition key and hold it in the start position (Figure 16). When the engine starts, release the key.

Important: If the engine does not start after 10 seconds of continuous cranking, turn the ignition key to off and let the starter motor cool for 60 seconds; refer to **Troubleshooting Troubleshooting**, page 39.

7. After the engine starts, move the choke lever to off (Figure 15). If the engine stalls or hesitates, move the choke lever back to on for a few seconds. Then move the throttle lever to desired setting. Repeat this as required.

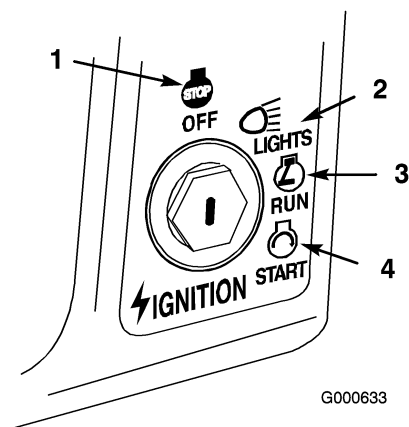

Figure 16

- | | |
|-----------|----------|
| 1. Off | 3. Run |
| 2. Lights | 4. Start |

Stopping the Engine

1. Push the PTO (power take off) to off (Figure 15).

2. Move the throttle lever between half and full throttle (Figure 15).
3. Turn the ignition key to off (Figure 16).

Operating the Power Take Off (PTO)

The power take off (PTO) engages and disengages power to the electric clutch.

While the ignition key is in run or lights position and the power take off (PTO) is engaged on, the PTO light, in the Indicator Module, will be on. When this light is on it is a reminder; the starter will not crank and to turn the off PTO before getting off.

Engaging the Power Take Off (PTO)

Pull the power take off (PTO) to on (Figure 17).

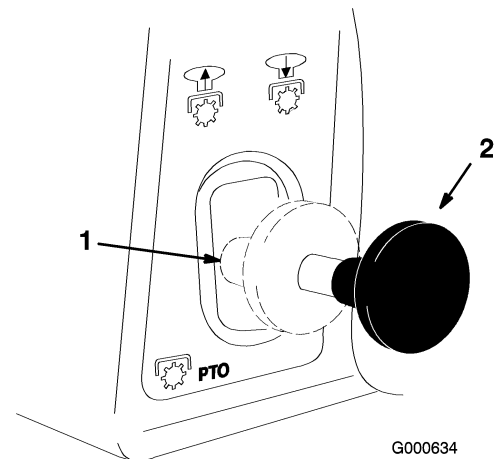

Figure 17

- | | |
|-------------------|---------------|
| 1. Off-disengaged | 2. On-engaged |
|-------------------|---------------|

Disengaging the Power Take Off (PTO)

Push the power take off (PTO) to off (Figure 17).

The Safety Interlock System



If safety interlock switches are disconnected or damaged the machine could operate unexpectedly causing personal injury.

- Do not tamper with the interlock switches.
- Check the operation of the interlock switches daily and replace any damaged switches before operating the machine.

Understanding the Safety Interlock System

The safety interlock system is designed to prevent the engine from starting unless:

- You are sitting on the seat.
- The brake pedal is depressed.
- The power take off (PTO) is off.
- The hydro control pedal is in the neutral position.

The safety interlock system is designed to stop the engine if:

- You rise from the seat when the brake pedal is released
- You rise from the seat when the power take off (PTO) is on.

The safety interlock system is designed to stop the power take off (PTO) if:

You shift into reverse with the power take off (PTO) engaged.

Testing the Safety Interlock System

Test the safety interlock system before you use the machine each time. If the safety system does not operate as described below, have an Authorized Service Dealer repair the safety system immediately.

1. Set the parking brake. Move the power take off (PTO) to the On position. Now turn the ignition key to start while sitting on the seat; the engine should not crank.
2. Push the power take off (PTO) to the off position and release the parking brake. Now turn the ignition key to the Start position while sitting on the seat; the engine should not crank.
3. Set the parking brake and move the power take off (PTO) to the Off position. Rise from the seat and turn the ignition key to the Start position; the engine should not crank.
4. Set the parking brake and move the power take off (PTO) to the Off position. While sitting in the seat, start the engine. While the engine is running, release the parking brake and rise slightly from the seat; the engine should stop.
5. Set the parking brake and move the power take off (PTO) to the Off position. While sitting in the seat, start the engine. While the engine is running, move the power take off (PTO) to the On position and rise slightly from the seat; the engine should stop.
6. With the parking brake released, turn the ignition key to the run position without starting the engine. Pull the PTO switch to on. You should hear an audible click indicating the PTO is activated and the PTO light will illuminate. Move the foot

pedal to reverse. You should hear an audible click indicating the PTO is deactivated and the PTO light should turn off.

7. With the parking brake released, turn the ignition switch to RUN without starting the engine. Pull the PTO switch to on. Turn the KeyChoice® key and release. The Operating-in-Reverse warning light should illuminate. Move the foot pedal to reverse. The PTO and PTO light on the dash should remain on. Push the PTO switch to off. The PTO light and the Operating-in-Reverse warning light should turn off.

Setting the KeyChoice® Switch to Operate in Reverse

An interlock feature on the tractor prevents the power take off (PTO) from operating when backing up. If you shift into reverse with the PTO engaged (i.e., with mower blades or other attachment running), the PTO will disengage. Do not mow in reverse unless absolutely necessary.

If you need to use the PTO while backing up, you can turn off this interlock feature using the KeyChoice® switch located near the seat bracket (Figure 18).



You could back over a child or bystander while the mower blade(s) or other attachment is engaged and cause serious injury or death.

- **Do not mow in reverse unless absolutely necessary.**
- **Do not insert the KeyChoice® key unless it is absolutely necessary.**
- **Always look backward and down before backing up.**
- **Use the KeyChoice® switch only if you are certain no children or other bystanders will enter the mowing area.**
- **Be very observant after deactivating the interlock because the sound of the engine may prevent you from noticing that a child or bystander has entered the work area.**
- **Always remove both the ignition and KeyChoice® keys and put them in a safe place out of the reach of children or unauthorized users when leaving the unit unattended.**

1. Engage the PTO.
2. Insert the KeyChoice® key into the switch (Figure 18).

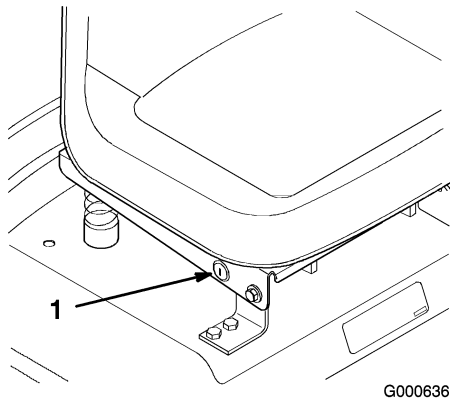

Figure 18

1. KeyChoice® switch

3. Turn the KeyChoice® key.

A red light on the front console (Figure 19 and Figure 20) turns on, indicating that the interlock is disabled.

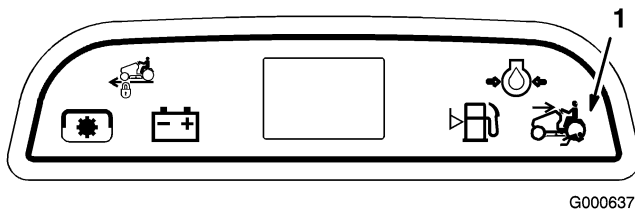

Figure 19

1. Operating-in-reverse light-Model 72202

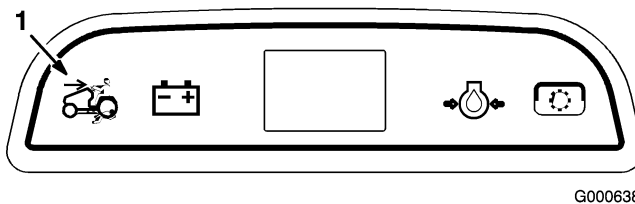

Figure 20

1. Operating-in-reverse light-Model 72201

4. Shift into reverse and complete your task.
5. Stop the PTO, which will turn off the red light on the console, to activate the interlock.
6. Remove the KeyChoice® key and put it in a safe place out of reach of children.

Driving Forward or Backward

The throttle control regulates the engine speed as measured in RPM (revolutions per minute). Place the throttle control in the fast position for best performance.

To go forward or backward, release the parking brake: refer to Releasing the Parking Brake in Brake Maintenance, page 37 . Place your foot on the traction control pedal and slowly press on the top of the traction control pedal to move forward or on the bottom of the traction control pedal to move backward (Figure 21) . The farther you move the traction control pedal in either direction, the faster the machine will move in that direction.

Note: For reverse motion, with the PTO engaged, the operating-in-reverse interlock must be deactivated by the KeyChoice® switch located on the seat bracket on the right hand side just below the seat.

To slow down, release the pressure on the traction control pedal.

Important: To avoid transmission damage, always release the parking brake before moving the traction control pedal.

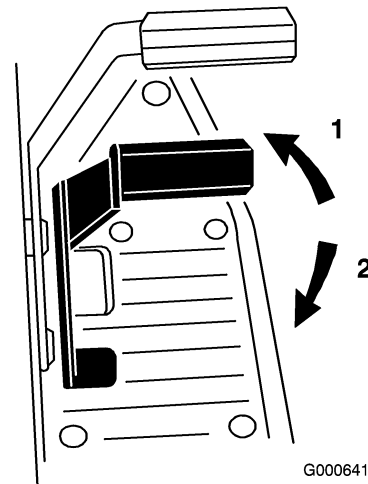

Figure 21

1. Forward
2. Backward

Stopping the Machine

To stop the machine, release the traction control pedal, disengage the power take off (PTO), and turn the ignition key to off. Also set the parking brake if you leave the machine unattended; refer to Setting the Parking Brake in Brake Maintenance, page 37 . Remember to remove the key from the ignition switch.



Children or bystanders may be injured if they move or attempt to operate the tractor while it is unattended.

Always remove the ignition and KeyChoice® keys and set the parking brake when leaving the machine unattended, even if just for a few minutes.

Operating the Attachment Lift Lever

The attachment lift lever (Figure 22) is used to raise and lower various attachments.

Raising an Attachment

Pull attachment lift lever rearward until latch locks. In this position the lift will hold the attachment in the up, or raised position.

Lowering an Attachment

Pull attachment lift lever rearward, to release lift pressure, and push the button on top to release the latch. Move lift lever forward to lower attachment.

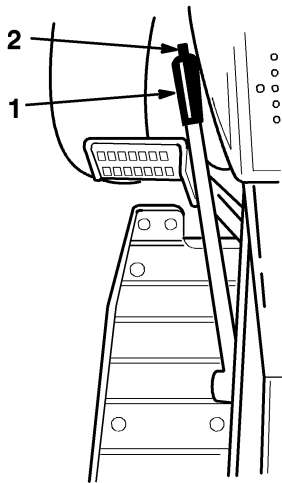

Figure 22

1. Lift lever 2. Button

Using the Attachment Power Lift

The attachment power lift (Figure 23) is used to raise and lower attachments.

Raising Attachments

1. Turn key to the on or run position (Figure 23).
2. Push the lift switch in the up direction to raise the attachment lift (Figure 23).

This will lift and hold the attachment in the up, or raised position.

Lowering Attachments

1. Turn key to the on or run position (Figure 23).
2. Push the lift switch in the down direction to lower the attachment lift (Figure 23).

This will lower the attachment lift.

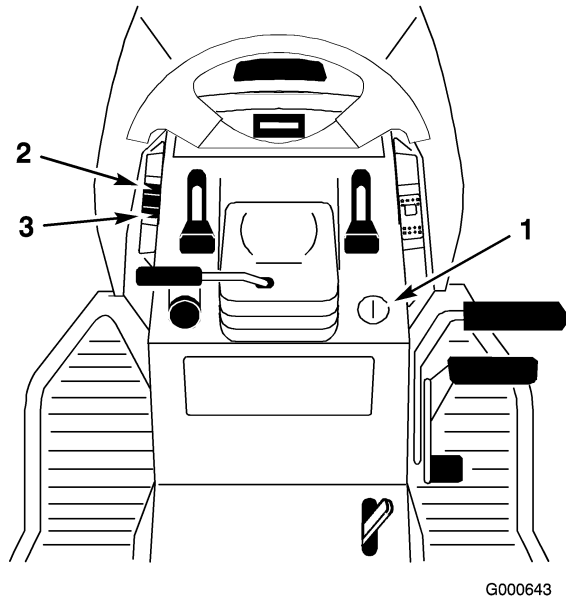

Figure 23

1. Key 3. Lift switch -down
2. Lift switch -up

Positioning the Seat

The seat can move forward and backward. Position the seat where you have the best control of the machine and are most comfortable.

1. Raise the seat and loosen the adjustment knobs (Figure 24).
2. Slide the seat to the desired position and tighten the knobs.

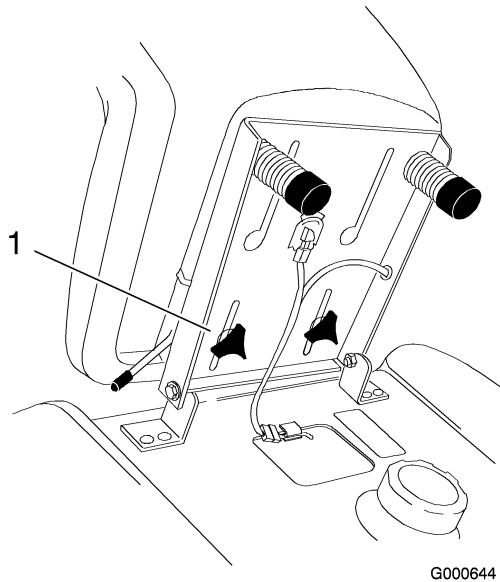

Figure 24

1. Adjustment knob

Using the Headlights

The headlights are turned on with a separate position, lights, of the ignition switch (Figure 25). The lights are on while the ignition switch is in the lights position even with the engine off. Remove the key when the machine is left unattended so lights can not be turned or discharging the battery.

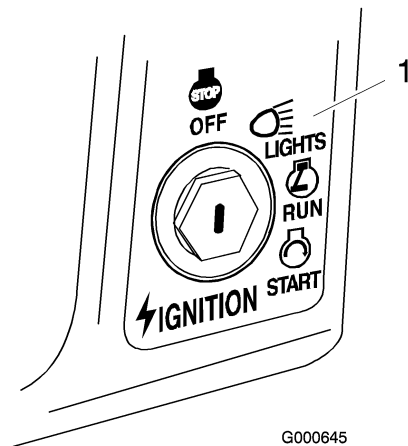

Figure 25

1. Lights

Positioning the Tilt Steering Wheel

The steering wheel has four tilt locations. Position the steering wheel where you have the best control of the machine and are most comfortable.

1. Lift the tilt lever to release the lock (Figure 26).
2. Move the steering wheel to a comfortable position; then release the lever to lock.

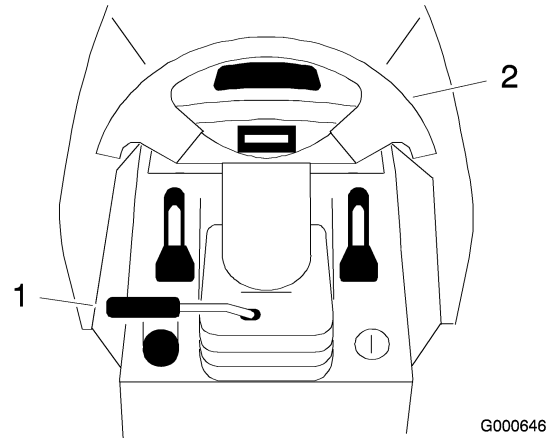

Figure 26

1. Tilt lever
2. Steering wheel

Pushing the Machine by Hand

Important: Always push the machine by hand. Never tow the machine because transaxle damage may occur.

To Push the Machine

1. Disengage the power take off (PTO) and turn the ignition key to off.
2. Move the drive control rod to the push position. This disengages the drive system and allows the wheels to turn freely (Figure 27).

To Operate the Machine

Move the drive control rod to the operate position (Figure 27).

Note: The machine will not drive unless the drive control rod is in the operate position.

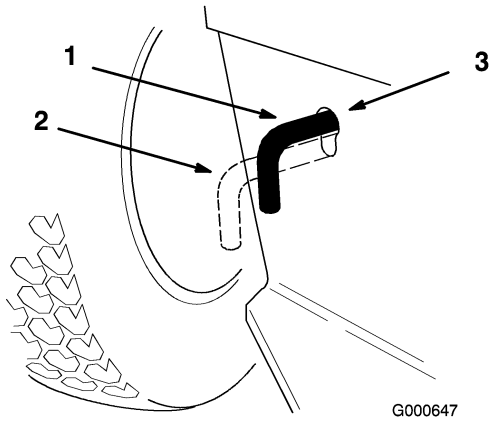

Figure 27

1. Operate position
2. Push position
3. Drive control rod

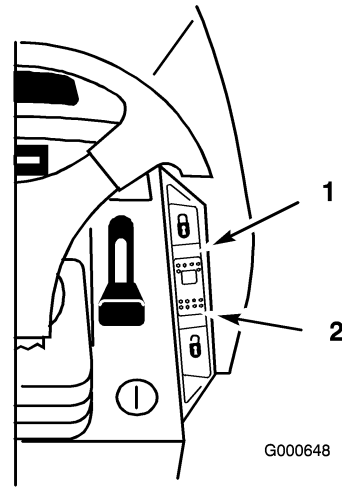

Figure 28

1. Lock-Set
2. Unlock-Off

Using the Cruise Control

A three position switch, located on the dash (Figure 28), with the functions of: Lock-Set (spring loaded), On and Unlock-Off controls the engagement. Cruise control maintains the traction control position without foot pressure. Cruise control is intended for operation in the forward direction only. Do not use cruise control in reverse.

Engaging the Cruise Control

1. Begin driving tractor: Refer to Driving Forward or Backward in Operation Operation, page 19 . While holding your foot steady on the traction control, push the cruise control switch (Figure 28) to the lock-set position.

2. This locks the traction control in position and your foot can then be removed from the traction control. A constant ground speed will be maintained.

Disengaging the Cruise Control

1. While holding your foot steady on the traction control, move the cruise control switch (Figure 28) to the unlock-off position.
2. This unlocks the traction control and your foot then operates the traction control.
3. For quick stops, just press on the brake pedal. This automatically disengages the cruise control and applies the brake at the same time.

Maintenance

Recommended Maintenance Schedule(s)

| Maintenance Service Interval | Maintenance Procedure |
|------------------------------|--|
| After the first use | <ul style="list-style-type: none"> • Change the engine oil. |
| Before each use or daily | <ul style="list-style-type: none"> • Check the safety interlock system. • Check the engine oil level. • Check the battery electrolyte. • Clean the air intake screen. • Check the brake. |
| Every 25 hours | <ul style="list-style-type: none"> • Clean the foam air cleaner element (more often in dusty dirty conditions). • Check the tire pressure. |
| Every 50 hours | <ul style="list-style-type: none"> • Grease the front wheels and spindles (more often in dirty or dusty conditions). • Clean the paper air cleaner element. |
| Every 100 hours | <ul style="list-style-type: none"> • Change the engine oil (more often in dirty or dusty conditions). • Check the spark plug(s). • Replace the fuel filter. • Clean the cooling fins and engine shrouds. |
| Every 200 hours | <ul style="list-style-type: none"> • Change the oil filter (more often in dirty or dusty conditions). • Replace the paper air cleaner element. |
| Before storage | <ul style="list-style-type: none"> • Drain the fuel. • Charge the battery and disconnect the cables. • Check the toe-in. • Perform all maintenance procedures listed above before storage. |

Important: Refer to your engine operator's manual for additional maintenance procedures.



If you leave the key in the ignition switch, someone could accidentally start the engine and seriously injure you or other bystanders.

Remove the key from the ignition and disconnect the wire from the spark plug before you do any maintenance. Set the wire aside so that it does not accidentally contact the spark plug.

Lubrication

Greasing and Lubrication

Grease the machine after every 50 operating hours or yearly, whichever occurs first. Grease more frequently when operating conditions are extremely dusty or sandy.

Grease Type: General-purpose grease.

How to Grease

1. Disengage the power take off (PTO), set the parking brake, and turn the ignition key to off. Remove the ignition key.
2. Clean the grease fittings with a rag. Make sure to scrape any paint off the front of the fitting(s).
3. Connect a grease gun to the fitting. Pump grease into the fittings until grease begins to ooze out of the bearings.
4. Wipe up any excess grease.

Where to Add Grease

1. Lubricate the front wheels and spindles until grease begins to ooze out of the bearings (Figure 29).
2. Lubricate the front axle pivot (Figure 29).

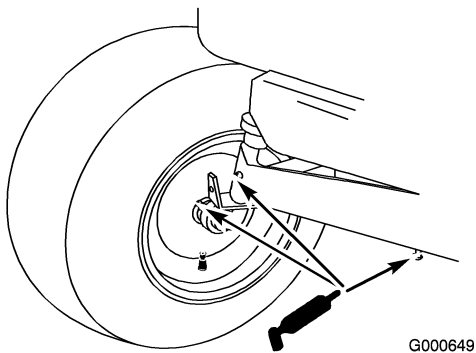

Figure 29

Engine Maintenance

Servicing the Engine Oil

Change the oil after the first 8 operating hours and every 100 operating hours thereafter.

Oil Type: Detergent oil (API service SF, SG, SH or SJ)

Crankcase Capacity:

- when the oil filter is not removed, 51 ounces (1.5 l)
- when the oil filter is removed, 58 ounces (1.7 l)

Viscosity: See the table below.

USE THESE SAE VISCOSITY OILS

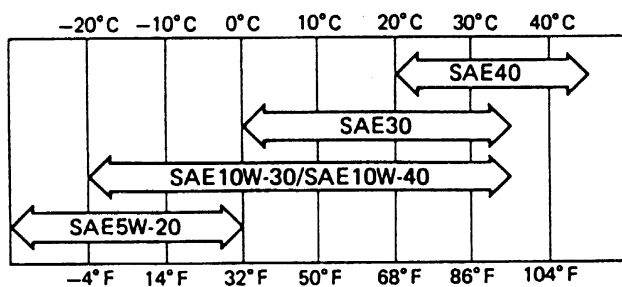

Figure 30

Checking the Engine Oil Level

1. Park the machine on a level surface, disengage the PTO, stop the engine, and remove the key.

2. Clean around the oil dipstick (Figure 31) so that dirt cannot fall into the filler hole and damage the engine.
3. Unscrew the oil dipstick and wipe the metal end clean (Figure 31).
4. Slide the oil dipstick fully into the filler tube, but do not thread it onto the tube (Figure 31). Pull the dipstick out and look at the metal end. If the oil level is low, slowly pour only enough oil into the filler tube to raise the level to the full mark on the dipstick.

Important: Do not overfill the crankcase with oil because the engine may be damaged.

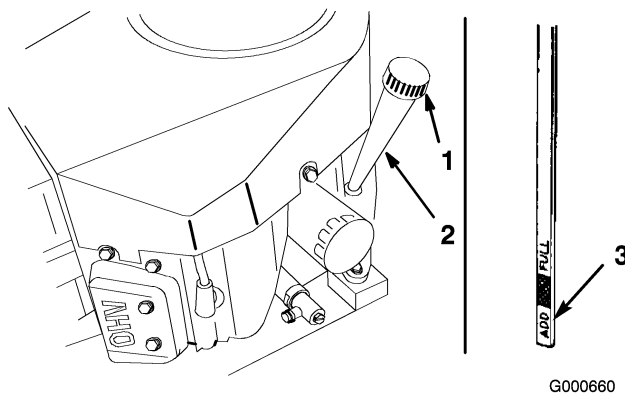

Figure 31

1. Oil dipstick
2. Filler tube
3. Dipstick end

Changing and Draining the Oil

1. Start the engine and let it run for five minutes. This warms the oil so that it drains better.
2. Park the machine so that the drain side is slightly lower than the opposite side to ensure that the oil drains completely. Then disengage the PTO, set the parking brake, stop the engine, and remove the key.
3. Place a pan below the oil drain. Use either a flat screw driver, 3/8 inch (10 mm) wrench to open valve (Figure 32).
4. Rotate valve end counterclockwise to open valve (Figure 32).
5. When oil has drained completely, rotate valve end clockwise to close the valve (Figure 32).

Note: Dispose of the used oil at a certified recycling center.

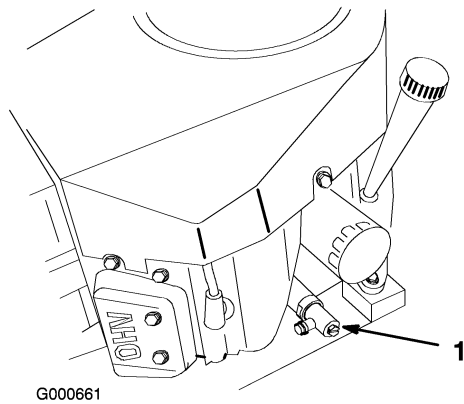

Figure 32

1. Oil drain

6. Clean around the oil dipstick and unscrew the cap (Figure 31).
7. Slowly pour approximately 80% of the specified oil into the filler cap (Figure 31). Refer to Servicing the Engine Oil in Engine Maintenance, page 28.
8. Check the oil level; refer to Checking the Engine Oil Level in Engine Maintenance, page 28.
9. Slowly add additional oil to bring it to the full mark.

Changing the Oil Filter

Replace the oil filter every 200 hours or every other oil change.

Note: Change the oil filter more frequently when operating conditions are extremely dusty or sandy.

1. Drain the oil from the engine; refer to Changing and Draining the Engine Oil in Engine Maintenance, page 28.
2. Remove the old filter (Figure 33).
3. Apply a thin coat of new oil to the rubber gasket on the replacement filter.

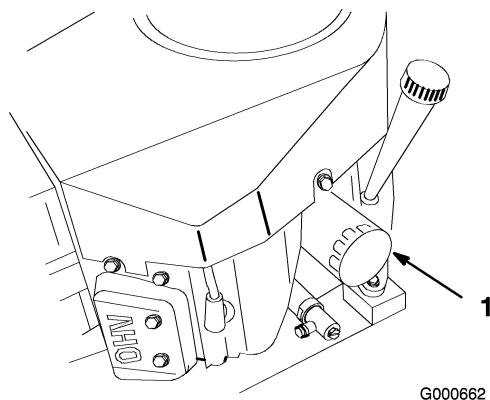

Figure 33

1. Oil filter

4. Install the replacement oil filter to the adapter. Turn the oil filter clockwise until the rubber gasket contacts the filter adapter, then tighten the filter an additional 3/4 turn (Figure 33).
5. Fill the crankcase with the proper type of new oil; refer to Changing and Draining the Engine Oil in Engine Maintenance, page 28.

Servicing the Air Cleaner

Foam Element: Clean and oil after every 25 operating hours.

Paper Element: Clean after every 50 operating hours. Replace after every 200 operating hours or yearly, whichever comes first.

Note: Service the air cleaner more frequently (every few hours) if operating conditions are extremely dusty or sandy.

Removing the Foam and Paper Elements

1. Disengage the PTO and set the parking brake.
2. Stop the engine, remove the key, and wait for all moving parts to stop before leaving the operating position.
3. Clean around the air cleaner to prevent dirt from getting into the engine and causing damage. Unlatch the two side latches and remove the air cleaner cover (Figure 34).

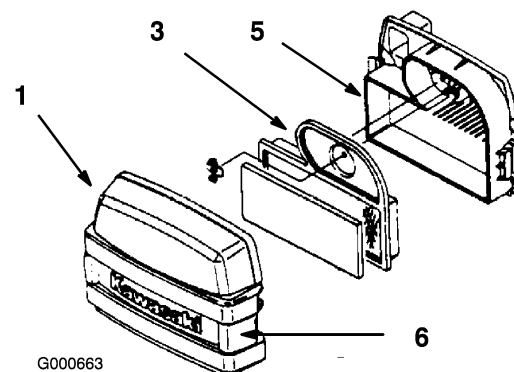

Figure 34

1. Cover
 2. Foam element
 3. Paper element
 4. Wing nut
 5. Air cleaner base
 6. Latches
4. Carefully remove the foam element from the paper element (Figure 34).
 5. Unscrew the wing nut and remove the paper element (Figure 34).

Cleaning the Foam Element

1. Wash the foam element in liquid soap and warm water (Figure 34). When the element is clean, rinse it thoroughly.
2. Dry the element by squeezing it in a clean cloth (do not wring). Allow the element to air dry.

Important: Replace the foam element if it is torn or worn.

Cleaning the Paper Element

1. Lightly tap the element on a flat surface to remove dust and dirt (Figure 35).
2. Inspect the element for tears, an oily film, and damage to the rubber seal.

Important: Never clean the paper element with pressurized air or liquids, such as solvent, gas, or kerosene. Replace the paper element if it is damaged or cannot be cleaned thoroughly.

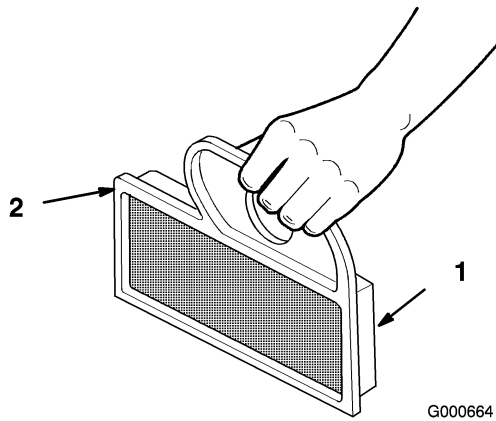

Figure 35

1. Paper element
2. Rubber seal

Installing the Foam and Paper Elements

Important: To prevent engine damage, always operate the engine with the complete foam and paper air cleaner assembly installed.

1. Carefully slide the foam element into the paper air cleaner element (Figure 34).
2. Place the air cleaner assembly onto the air cleaner base and install the wing nut (Figure 34).
3. Install the air cleaner cover and latch it (Figure 34).

Servicing the Spark Plug

Check the spark plug(s) after every 100 operating hours. Make sure the air gap between the center and

side electrodes is correct before installing the spark plug. Use a spark plug wrench for removing and installing the spark plug(s) and a gapping tool/feeler gauge to check and adjust the air gap. Install a new spark plug(s) if necessary.

Type: Champion RCJ8Y (or equivalent)

Air Gap: 0.030 inch (0.75 mm)

Removing the Spark Plug(s)

1. Disengage the PTO and set the parking brake.
2. Stop the engine, remove the key, and wait for all moving parts to stop before leaving the operating position.
3. Pull the wire(s) off of the spark plug(s) (Figure 36). Clean around the spark plug(s) to prevent dirt from falling into the engine and potentially causing damage.
4. Remove the spark plug(s) and metal washer.

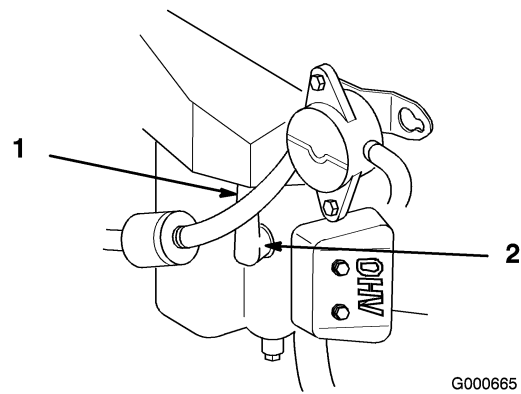

Figure 36

1. Spark plug wire installed
2. Spark plug

Checking the Spark Plug

1. Look at the center of the spark plug(s) (Figure 37). If you see light brown or gray on the insulator, the engine is operating properly. A black coating on the insulator usually means the air cleaner is dirty.

Important: Never clean the spark plug(s). Always replace the spark plug(s) when it has a black coating, worn electrodes, an oily film, or cracks.

2. Check the gap between the center and side electrodes (Figure 37). Bend the side electrode (Figure 37) if the gap is not correct.

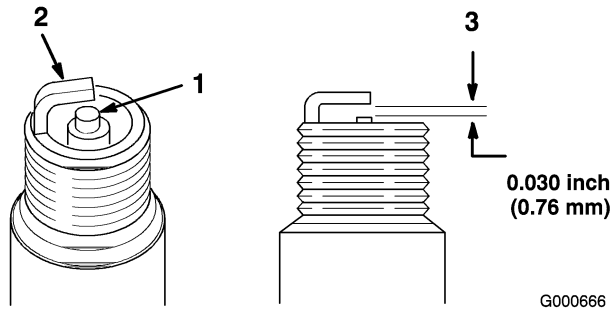

Figure 37

1. Center electrode insulator
2. Side electrode
3. Air gap (not to scale)

Installing the Spark Plug(s)

1. Install the spark plug(s). Make sure that the air gap is set correctly.
2. Tighten the spark plug(s) to 16 ft-lb (22 N m).
3. Push the wire(s) onto the spark plug(s) (Figure 36).

Fuel System Maintenance

Draining The Fuel Tank



In certain conditions, gasoline is extremely flammable and highly explosive. A fire or explosion from gasoline can burn you and others and can damage property.

- Drain gasoline from the fuel tank when the engine is cold. Do this outdoors in an open area. Wipe up any gasoline that spills.
- Never smoke when draining gasoline, and stay away from an open flame or where a spark may ignite the gasoline fumes.

1. Park the machine on a level surface, to ensure the fuel tank drains completely. Disengage the PTO and set the parking brake.
2. Stop the engine, remove the key, and wait for all moving parts to stop before leaving the operating position.
3. Close the fuel shut-off valve at the fuel tank (Figure 38).

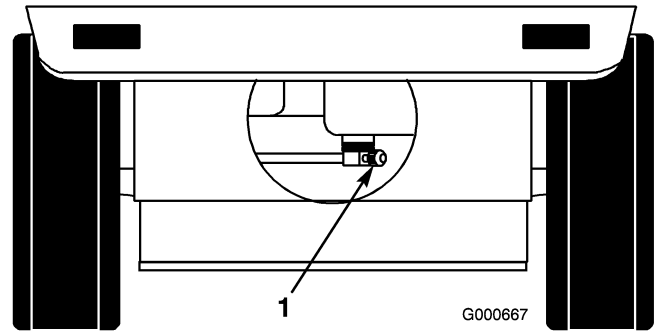

Figure 38

1. Fuel shut-off valve

4. Open the hood.
5. Squeeze the ends of the hose clamp together and slide it up the fuel line toward the fuel tank (Figure 39).

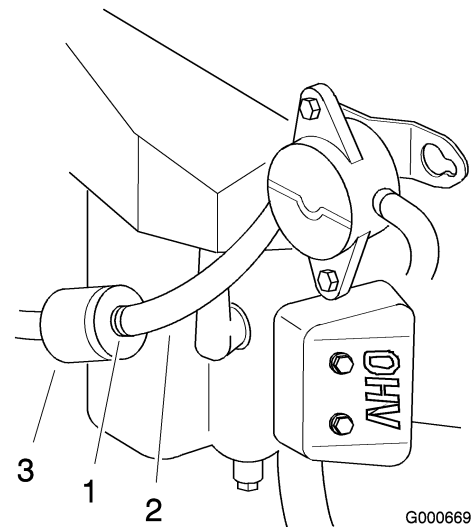

Figure 39

1. Hose clamp
2. Fuel line
3. Filter

6. Pull the fuel line off the filter (Figure 39). Open fuel shut-off valve and allow gasoline to drain into an approved gas can.

Note: Now is the best time to install a new fuel filter because the fuel tank is empty.

7. Install the fuel line onto the filter. Slide the hose clamp close to the filter to secure the fuel line and filter; Refer to Replacing the Fuel Filter in Fuel System Maintenance, page 31.

Servicing the Fuel Filter

Replace the fuel filter after every 100 operating hours or yearly, whichever occurs first.

Never install a dirty filter if it is removed from the fuel line.

1. Disengage the PTO and set the parking brake.
2. Stop the engine, remove the key, and wait for all moving parts to stop before leaving the operating position.
3. Close fuel shut-off valve at fuel tank (Figure 38).
4. Open the hood.
5. Squeeze the ends of the hose clamps together and slide them away from the filter (Figure 39).
6. Remove the filter from the fuel lines.
7. Install a new filter and move the hose clamps close to the filter.
8. Open fuel shut-off valve at fuel tank (Figure 38).
9. Close the hood.

Electrical System Maintenance

Servicing the Fuses

The electrical system is protected by fuses. It requires no maintenance, however, if a fuse blows check component/circuit for malfunction or short. To replace fuses pull up on the fuse (Figure 40) to remove or replace it.

Fuses:

- Main/Starter F1-30 amp, blade-type
- Alternator F2-25 amp, blade-type
- Dash/Hour meter F3-10 amp, blade-type
- Head lights F4-10 amp, blade-type
- Power attachment lift F5-25 amp, blade-type (Model 430 only)
-

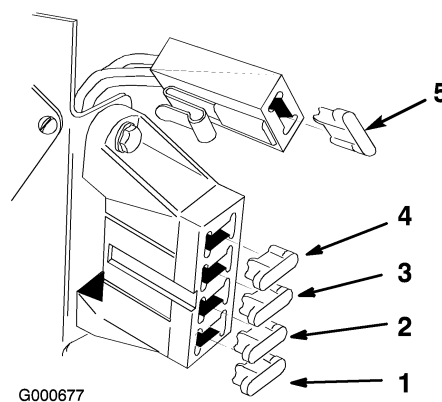

Figure 40

1. Main-30 amp
2. Alternator-25 amp
3. Dash/Hour meter-10 amp
4. Head lights-10 amp
5. Power attachment lift-25 amp (Model 72202 only)

Servicing the Headlights

Specification: Bulb #1156 Automotive Type

Removing the Bulb

1. Disengage the PTO and set the parking brake.
2. Stop the engine, remove the key, and wait for all moving parts to stop before leaving the operating position.
3. Open the hood. Pull wire connectors off both bulb holder terminals.
4. Rotate the bulb holder 1/4 turn counterclockwise and remove it from the reflector (Figure 41).
5. Push and rotate the bulb counterclockwise until it stops (approximately a 1/4 turn) and remove bulb from the bulb holder (Figure 41).

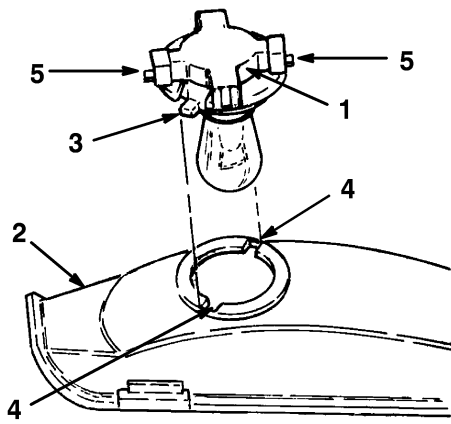

G000678

Figure 41

- | | |
|----------------|--------------|
| 1. Bulb holder | 4. Slots |
| 2. Reflector | 5. Terminals |
| 3. Tabs | |

Installing the Bulb

- The bulb has metal pins on the side of its base. Align the pins with the slots in the bulb holder and insert the base into the holder (Figure 42). Push and rotate the bulb clockwise until it stops.

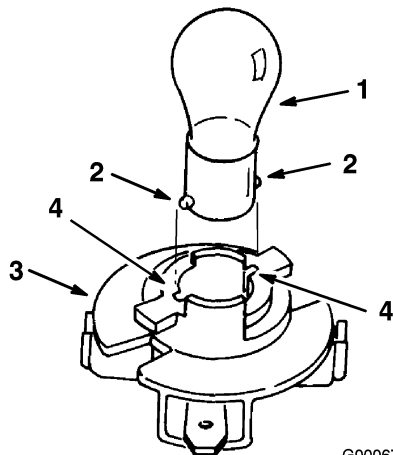

G000679

Figure 42

- | | |
|---------------|----------------|
| 1. Bulb | 3. Bulb holder |
| 2. Metal pins | 4. Slots |

- The bulb holder has two tabs (Figure 41). Align the tabs with the slots in the reflector, insert the bulb holder into the reflector and rotate it 1/4 turn clockwise until it stops.
- Push the wire connectors onto the terminals on the bulb holder.

Servicing the Battery

Warning

CALIFORNIA
Proposition 65 Warning

Battery posts, terminals, and related accessories contain lead and lead compounds, chemicals known to the State of California to cause cancer and reproductive harm. Wash hands after handling.

Always keep the battery clean and fully charged. Use a paper towel to clean the battery case. If the battery terminals are corroded, clean them with a solution of four parts water and one part baking soda. Apply a light coating of grease to the battery terminals to prevent corrosion.

Voltage: 12 v, 260 Cold Cranking Amps

Removing the Battery



Battery terminals or metal tools could short against metal tractor components causing sparks. Sparks can cause the battery gasses to explode, resulting in personal injury.

- When removing or installing the battery, do not allow the battery terminals to touch any metal parts of the tractor.
- Do not allow metal tools to short between the battery terminals and metal parts of the tractor.



Incorrect battery cable routing could damage the tractor and cables causing sparks. Sparks can cause the battery gasses to explode, resulting in personal injury.

- Always disconnect the negative (black) battery cable before disconnecting the positive (red) cable.
- Always reconnect the positive (red) battery cable before reconnecting the negative (black) cable.

- Disengage the PTO and set the parking brake.
- Stop the engine, remove the key, and wait for all moving parts to stop before leaving the operating position.
- Open the hood and locate the battery.

- Remove the right side panel for clearance when removing battery Figure 43).

Remove the screws and lift up the panel to clear the pin and slide panel tabs out from the steering tower.

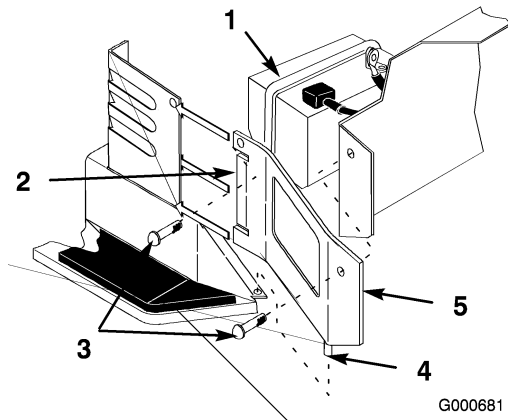

Figure 43

- | | |
|--------------------|---------------------|
| 1. Battery | 4. Pin |
| 2. Side panel tabs | 5. Right side panel |
| 3. Screw | |

- Disconnect the negative (black) ground cable from the battery post (Figure 44).

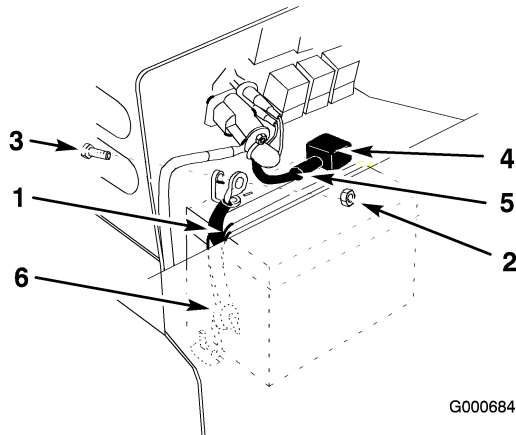

Figure 44

- | | |
|-------------------|----------------------------|
| 1. Negative cable | 4. Rubber cover (red) |
| 2. Nut | 5. Positive cable |
| 3. Bolt | 6. Battery hold down strap |

- Lift the red cover up from the positive cable. Disconnect the positive cable (red cover) from the battery post (Figure 44).
- Remove the battery hold down strap (Figure 44). Remove battery from the tractor.

Installing the Battery

- Install the battery into the tractor (Figure 43).
- Secure battery with hold down strap (Figure 44).

- Using the bolt and nut, connect the positive (red cover) cable to the positive (+) battery post (Figure 44). Slide the rubber cover over the battery post.
- Using the bolt and nut, connect the negative (black) cable to the negative (-) battery post (Figure 44).
- Install the right side panel by sliding tabs into steering tower and inserting pin into flange of footrest. Secure with screws (Figure 43).

Checking the Electrolyte Level

- With the engine off, open the hood to locate the battery.
- Look at the side of the battery. The electrolyte must be up to the upper line. Do not allow the electrolyte to get below the lower line (Figure 45).

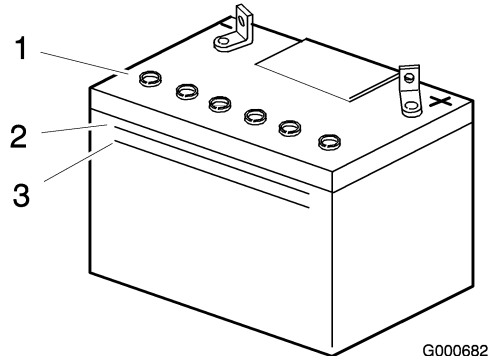

Figure 45

- | | |
|----------------|---------------|
| 1. Filler caps | 3. Lower line |
| 2. Upper line | |

- If the electrolyte is low, add the required amount of distilled water; refer to Adding Water to the Battery in .



Battery electrolyte contains sulfuric acid which is a deadly poison and causes severe burns.

- Do not drink electrolyte and avoid contact with skin, eyes or clothing. Wear safety glasses to shield your eyes and rubber gloves to protect your hands.
- Fill the battery where clean water is always available for flushing the skin.
- Follow all instructions and comply with all safety messages on the electrolyte container.

Adding Water to the Battery

The best time to add distilled water to the battery is just before you operate the machine. This lets the water mix thoroughly with the electrolyte solution.

1. Remove the battery from the tractor.
2. Clean the top of the battery with a paper towel.

Note: Never fill the battery with distilled water while the battery is installed in the tractor. Electrolyte could be spilled on other parts and cause corrosion.

3. Remove the vent caps from the battery (Figure 46).

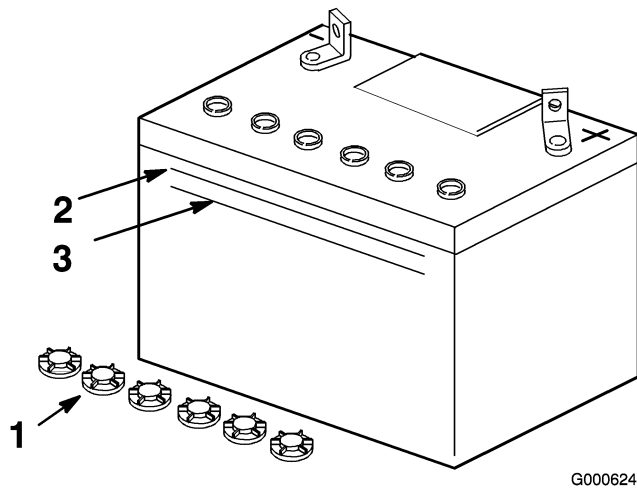

Figure 46

1. Filler caps
2. Upper line
3. Lower line

4. Slowly pour distilled water into each battery cell until the level is up to the upper line (Figure 46) on the battery case.

Important: Do not overfill the battery because electrolyte (sulfuric acid) can cause severe corrosion and damage to the chassis.

5. Wait five to ten minutes after filling the battery cells. Add distilled water, if necessary, until the electrolyte level is up to the upper line (Figure 46) on the battery case.
6. Reinstall battery vent caps.

Charging the Battery



Charging the battery produces gasses that can explode.

Never smoke near the battery and keep sparks and flames away from battery.

Important: Always keep the battery fully charged (1.265 specific gravity). This is especially important to prevent battery damage when the temperature is below 32°F (0°C).

1. Remove the battery from the chassis; refer to Removing the Battery.
2. Check the electrolyte level; refer to Checking Electrolyte Level.
3. Make sure the filler caps are installed in battery. Charge battery for a minimum of 6 to 10 amps for one hour. If the battery is in the fully discharged condition, then the charging requirement is 3 amps for 6 hours.

Important: Never over charge the battery. Excessive charging will shorten the battery life.

4. When the battery is fully charged, unplug the charger from the electrical outlet, then disconnect the charger leads from the battery posts (Figure 47).

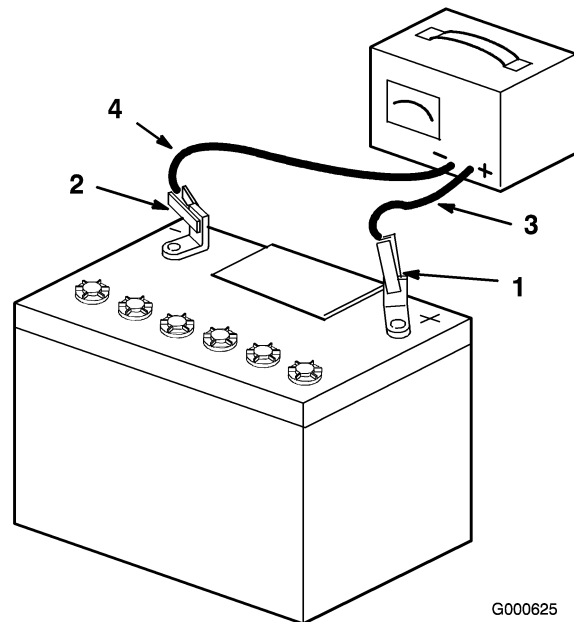

Figure 47

1. Positive Battery Post
2. Negative Battery Post
3. Red (+) Charger Lead
4. Black (-) Charger Lead

5. Install the battery in the tractor and connect the battery cables; refer to Installing the Battery.

Note: Do not run the tractor with the battery disconnected, electrical damage may occur.

Drive System Maintenance

Checking the Tire Pressure

Maintain the air pressure in the front and rear tires as specified. Check the pressure at the valve stem after every 25 operating hours or monthly, whichever occurs first (Figure 48). Check the tires when they are cold to get the most accurate pressure reading.

Pressure: 20 psi (138 kPa) front and rear tires

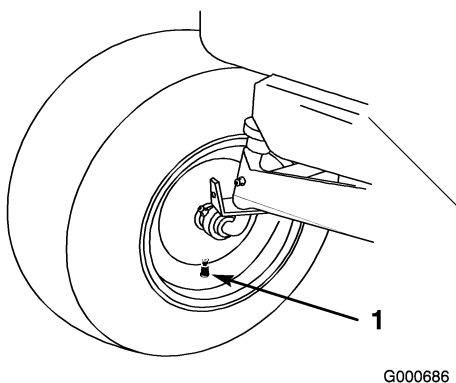

Figure 48

1. Valve stem

Servicing the Front Wheel Toe-In

Maintain toe-in of the front wheels as specified. If uneven tire wear, lawn scuffing or hard steering develop adjustment may be required. Check the toe-in every year before storage.

Specification: 1/8-1/4 inch (3-6 mm) toe-in on front wheels.

Measuring the Toe-in

1. Disengage the PTO and set the parking brake.
2. Stop the engine, remove the key, and wait for all moving parts to stop before leaving the operating position.
3. Push front tires out, at front, to remove normal looseness in the linkage.
4. Measure, between the rims, at spindle level, in the front and rear of the wheels (Figure 49).

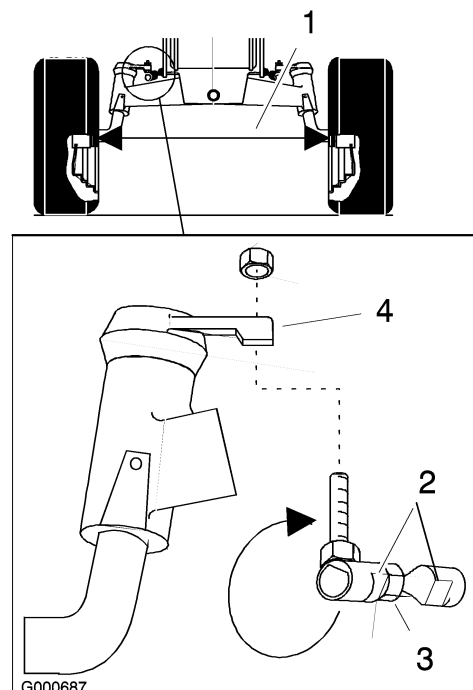

Figure 49

1. Measure here
2. Flats
3. Jam nut
4. Steering lever

5. The front measurement should be less than the rear, as specified.

Adjusting the Toe-In

1. Check the toe-in before you adjust it; refer to Measuring Toe-In.
2. Remove ball joint from one steering lever (Figure 49).
3. Loosen jam nut securing ball joint to steering rod. Rotate ball joint one turn, clockwise to increase or counter clockwise to decrease toe-in.
4. Hold flats on ball joint to align with flats on tie rod and tighten jam nut (Figure 49).
5. Install ball joint to steering lever and check the toe-in; refer to Measuring Toe-In.

Important: If more than one turn is required to meet specifications, alternate between left and right steering rods to maintain steering wheel alignment.

Transaxle Fluid

The transaxle is a sealed system and no checking or changing of the fluid is required.

Important: If any transaxle problems arise, contact your local Authorized Service Dealer for help and service.

Cooling System Maintenance

Cleaning the Cooling System

Clean the air intake screen from grass and debris before each use.

Clean the cooling fins and engine shrouds every 100 hours.

1. Disengage the PTO, set the parking brake, stop the engine, and remove the key.
2. Remove the air intake screen, cylinder covers, and fan housing (Figure 50).

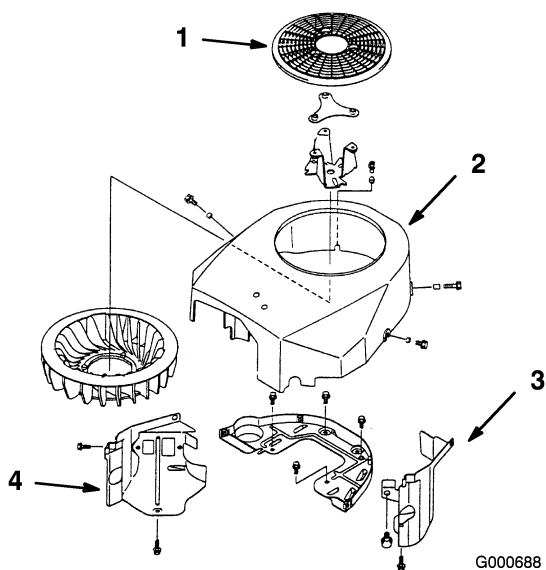

Figure 50

- | | |
|----------------------|-------------------|
| 1. Air intake screen | 3. Cylinder cover |
| 2. Fan housing | 4. Cylinder cover |

3. Clean debris and grass from the parts.
4. Install the air intake screen, cylinder covers, and fan housing.

Brake Maintenance

Servicing the Brake

Always set the parking brake when you stop the machine or leave it unattended. If the parking brake does not hold securely, an adjustment is required.

Checking the Brake

1. Park the machine on a level surface, disengage the PTO, and set the parking brake.

2. Stop the engine, remove the key, and wait for all moving parts to stop before leaving the operating position.
3. Rear wheels must lock and skid when you try to push the tractor forward. Adjustment is required if the wheels turn and do not lock; refer to Adjusting the Brake.
4. Release the brake and move the drive control rod to the push position; refer to Pushing the Machine by Hand in Operation, page 19. Wheels should rotate freely.
5. If both conditions are met no adjustment is required.

Adjusting the Brake

1. Check the brake before you adjust it; refer to Checking the Brake.
2. Release the parking brake; refer to Releasing the Parking Brake in Operation, page 19
3. To adjust the brake remove the cotter pin and loosen the brake adjusting nut slightly (Figure 51).

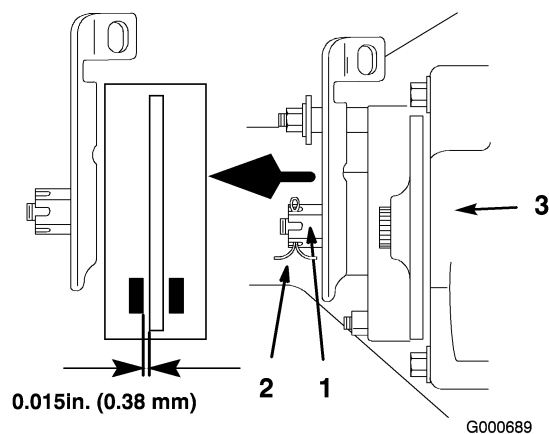

Figure 51

- | | |
|------------------------|-----------------------------|
| 1. Brake adjusting nut | 3. Right Front of Transaxle |
| 2. Cotter pin | |

4. Carefully insert a 0.015 inch (0.38 mm) feeler gauge between the outer brake pad and rotor disk (Figure 51).
5. Tighten the brake adjusting nut until slight resistance is felt on the feeler gauge when sliding it in and out. Install the cotter pin.
6. Check the brake operation again; refer to Checking the Brake.

Important: With the parking brake released, the rear wheels must rotate freely when you push the mower. If the 0.015 inch (0.38 mm) clearance and free wheel rotation cannot be achieved contact your service dealer immediately.

Storage

Cleaning and Storage

1. Disengage the power take off (PTO), set the parking brake, and turn the ignition key to off. Remove the ignition and KeyChoice® keys.
2. Remove grass clippings, dirt, and grime from the external parts of the entire machine, especially the engine. Clean dirt and chaff from the outside of the engine's cylinder head fins and blower housing.

Important: You can wash the machine with mild detergent and water. Do not pressure wash the machine. Avoid excessive use of water, especially near the control panel, lights, engine, and the battery.

3. Check the brake; refer to Servicing the Brake in Brake Maintenance, page 37
4. Service the air cleaner; refer to Servicing the Air Cleaner in Engine Maintenance, page 28.
5. Grease the chassis; refer to Greasing and Lubrication in Lubrication, page 27.
6. Change the crankcase oil and filter; refer to Servicing the Engine Oil in Engine Maintenance, page 28 .
7. Check the tire pressure; refer to Checking the Tire Pressure in Drive System Maintenance, page 36.
8. Prepare the machine for storage when non-use occurs over 30 days. Prepare machine for storage as follows.
 - A. Add a petroleum based stabilizer/conditioner to fuel in the tank. Follow mixing instructions from stabilizer manufacture. Do not use an alcohol based stabilizer (ethanol or methanol).

Note: A fuel stabilizer/conditioner is most effective when mixed with fresh gasoline and used at all times.
 - B. Run engine to distribute conditioned fuel through the fuel system (5 minutes).
 - C. Stop engine, allow to cool and drain the fuel tank; refer to Servicing the Fuel Tank in Fuel System Maintenance, page 31.
 - D. Restart engine and run it until it stops.
 - E. Choke or prime the engine. Start and run engine until it will not start. Operate primer, if equipped on machine, several times to ensure fuel remains in primer system.
 - F. Dispose of fuel properly. Recycle as per local codes.

Important: Do not store stabilizer/conditioned gasoline over 90 days.

9. Remove the spark plug(s) and check its condition; refer to Servicing the Spark Plug in Engine Maintenance, page 28 . With the spark plug(s) removed from the engine, pour two tablespoons of engine oil into the spark plug hole. Now use the electric starter to crank the engine and distribute the oil inside the cylinder. Install the spark plug(s) and tighten it to 30 ft-lb (40 N·m). Do not install the wire on the spark plug(s).
10. Disconnect the negative battery cable. Clean the battery and battery terminals. Check the electrolyte level and charge it fully; refer to Servicing the Battery in Electrical System Maintenance, page 32 . Leave the negative battery cable disconnected from the battery during storage.

Important: The battery must be fully charged to prevent it from freezing and being damaged at temperatures below 32°F (0°C). A fully charged battery can be stored one winter season without recharging.

11. Check and tighten all bolts, nuts, and screws. Repair or replace any part that is damaged.
12. Paint all scratched or bare metal surfaces. Paint is available from your Authorized Service Dealer.
13. Store the machine in a clean, dry garage or storage area. Remove the keys from the ignition and KeyChoice® switches and keep it in a memorable place. Cover the machine to protect it and keep it clean.

Troubleshooting

| Problem | Possible Cause | Corrective Action |
|---|--|---|
| Starter does not crank | <ol style="list-style-type: none"> 1. Blade control (PTO) is engaged. 2. Parking brake is not on. 3. Operator is not seated. 4. Battery is dead. 5. Electrical connections are corroded or loose. 6. Fuse is blown. 7. Relay or switch is defective. | <ol style="list-style-type: none"> 1. Move the blade control (PTO) to disengaged. 2. Set the parking brake. 3. Sit on the seat. 4. Charge the battery. 5. Check the electrical connections for good contact. 6. Replace the fuse. 7. Contact an Authorized Service Dealer. |
| Engine will not start, starts hard, or fails to keep running. | <ol style="list-style-type: none"> 1. Fuel tank is empty. 2. Choke is not on. 3. Air cleaner is dirty. 4. Spark plug wire is loose or disconnected. 5. Spark plug is pitted, fouled, or the gap is incorrect. 6. Dirt in the fuel filter. 7. Dirt, water, or stale fuel is in the fuel system. | <ol style="list-style-type: none"> 1. Fill fuel tank with gasoline. 2. Move the throttle lever to choke position. 3. Clean or replace the air cleaner element. 4. Install wire on spark plug. 5. Install a new, correctly gapped spark plug. 6. Replace the fuel filter. 7. Contact an Authorized Service Dealer. |
| Engine loses power. | <ol style="list-style-type: none"> 1. Engine load is excessive. 2. Air cleaner is dirty. 3. Oil level in the crankcase is low. 4. Cooling fins and air passages under the engine blower housing are plugged. 5. Spark plug is pitted, fouled, or the gap is incorrect. 6. Vent hole in the fuel cap is plugged. 7. Dirt in the fuel filter. 8. Dirt, water, or stale fuel is in the fuel system. | <ol style="list-style-type: none"> 1. Reduce the ground speed. 2. Clean the air cleaner element. 3. Add oil to the crankcase. 4. Remove the obstruction from the cooling fins and air passages. 5. Install a new, correctly gapped spark plug. 6. Clean or replace the fuel cap. 7. Replace the fuel filter. 8. Contact an Authorized Service Dealer. |

| Problem | Possible Cause | Corrective Action |
|-------------------------|--|---|
| Engine overheats. | <ol style="list-style-type: none"> 1. Engine load is excessive. 2. Oil level in the crankcase is low. 3. Cooling fins and air passages under the engine blower housing are plugged. | <ol style="list-style-type: none"> 1. Reduce the ground speed. 2. Add oil to the crankcase. 3. Remove the obstruction from the cooling fins and air passages. |
| Abnormal vibration. | <ol style="list-style-type: none"> 1. Engine mounting bolts are loose. 2. Loose engine pulley, idler pulley, or blade pulley. 3. Engine pulley is damaged. | <ol style="list-style-type: none"> 1. Tighten the engine mounting bolts. 2. Tighten the appropriate pulley. 3. Contact an Authorized Service Dealer. |
| Machine does not drive. | <ol style="list-style-type: none"> 1. Drive control is in the push position. 2. Traction belt is worn, loose or broken. 3. Traction belt is off the pulley. | <ol style="list-style-type: none"> 1. Move the drive control to the operate position. 2. Contact and Authorized Service Dealer. 3. Contact an Authorized Service Dealer. |

Schematics

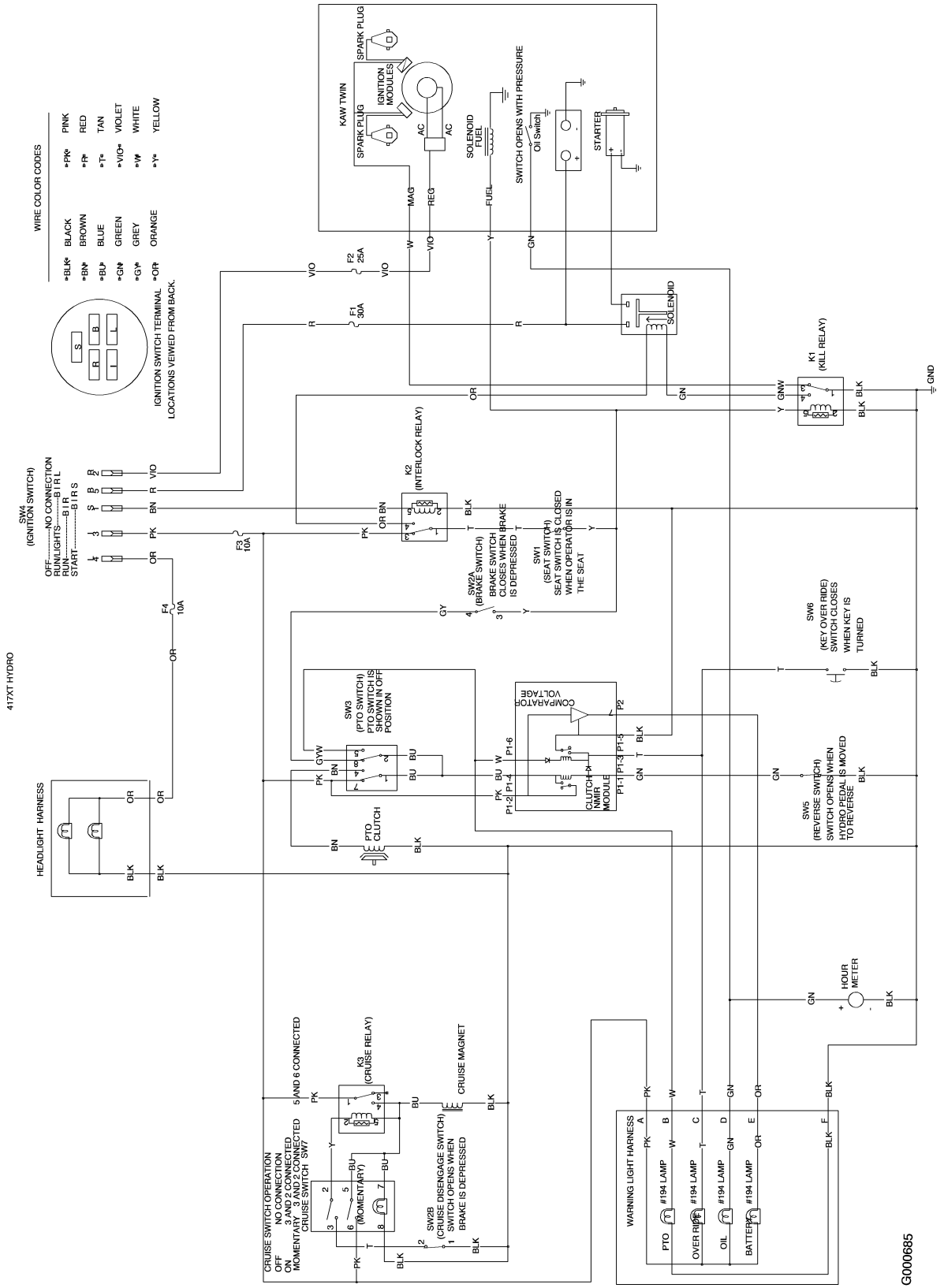

G000685

Wiring Schematic (Model 420) (Rev. A)

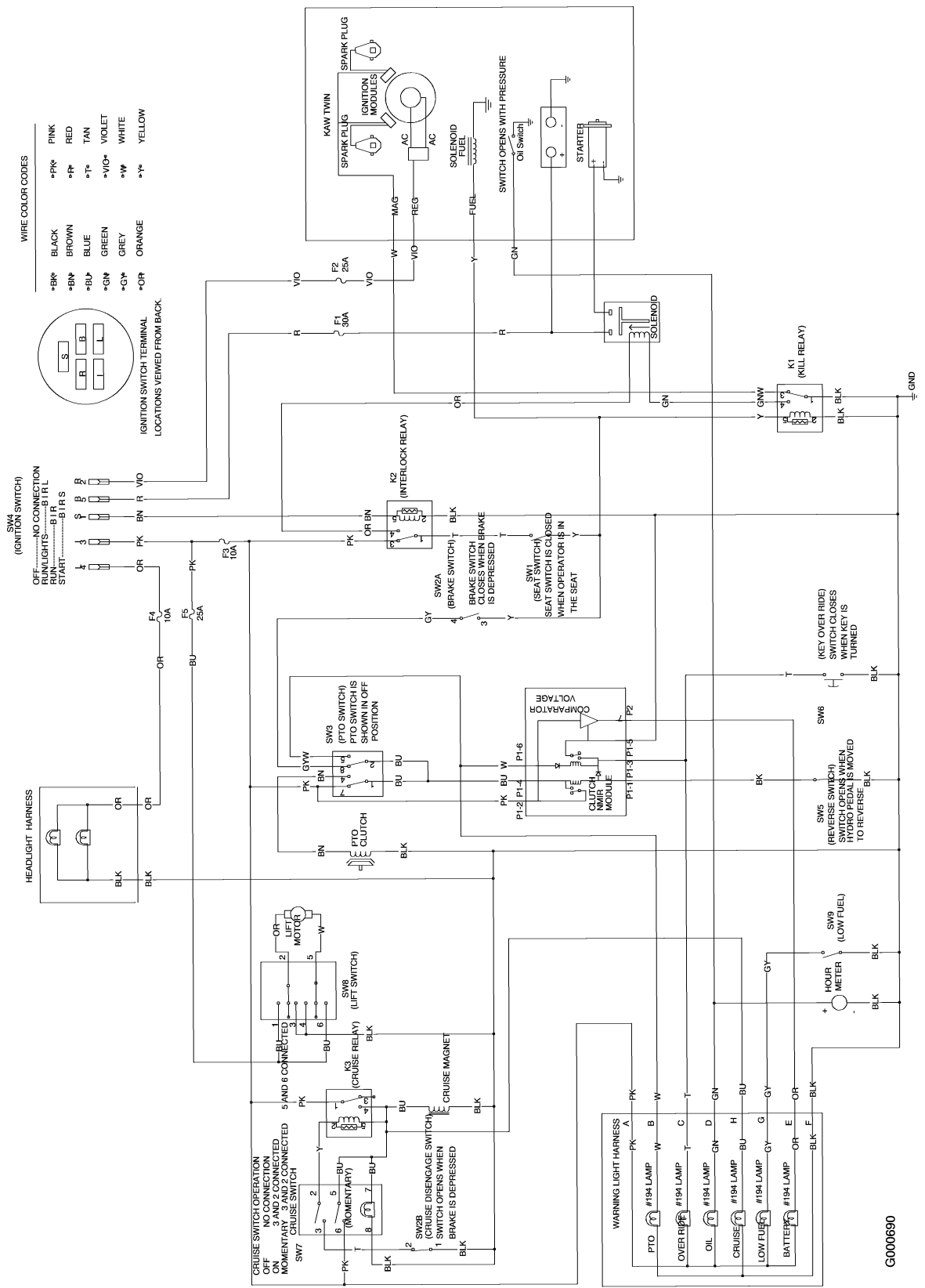

Wiring Schematic (Model 430) (Rev. A)

G000690



Count on it.