



## Foam Marker Kit

### Multi-Pro<sup>®</sup> 1200, 1250, 5600 and 5700 Turf Sprayers and Workman<sup>®</sup> 200 Spray Systems

Model No. 41228 - 250000001 and up.

## Parts Catalog

### Ordering Replacement Parts

To order replacement parts, please supply the part number, the quantity, and the description of each part desired.

### Understanding Reference Numbers

Each Identified part in an illustration has a reference number. The reference number for a part also appears in the parts list, along with other information about the part.

This catalog uses two special reference number formats, one to indicate parts in a service assembly and another to indicate the quantity of a given part in an illustration.

### Service Assembly Reference Numbers

Parts in service assemblies have reference numbers in the form a:b. The a represents the reference number of the entire service assembly and the b represents a sequential number unique to each part within the service assembly.

For example, a wheel assembly might be identified by reference number 6, the tire by 6:1, the valve by 6:2, and the wheel by 6:3. When you order the assembly identified by reference number 6, you receive all parts identified by reference numbers 6:1, 6:2, and 6:3. However, you may also order any part individually. Reference numbers of this type appear in illustrations and in part lists.

### Reference Numbers Indicating Quantity

In an illustration, if a reference number indicates more than one part, the reference number has the form nX y. The n represents the quantity of the part, the X is the multiplication symbol, and the y represents the reference number.

For example, in an illustration, the reference number 2X 37 means that two of the parts identified by reference number 37 are indicated.

# Contents

Description	Page	Description	Page
Sprayer Tank Assembly	..... 3	Solenoid Valve Assembly	..... 5
Valve Assembly	..... 4	Frame and Compressor Assembly	..... 6
		Electrical Component Assembly	..... 7

## Part Description Abbreviations

Part descriptions in this catalog may include the following abbreviations.

AR. .... as required	HYD. .... hydraulic
ASM. .... assembly	INC. .... incorporated
CARR. .... carriage	LH. .... left hand
DEG. .... degrees	NI. .... nylon insert
EXT. .... external	NPTF. .... national pipe thread fine
FH. .... flat head	PPH. .... phillips pan head
GA. .... gauge	PRH. .... phillips round head
HF. .... hex flange	PTH. .... phillips truss head
HH. .... hex head	PTO. .... power take off
HHF. .... hex head flange	RH. .... right hand
HHFTF. .... hex head flange thread forming	ROPS. .... roll over protection system
HJ. .... hex jam	SFH. .... slotted fillister head
HLH. .... hex lag head	SHH. .... slotted hex head
HOC. .... height-of-cut	SHWH. .... slotted hex washer head
HS. .... hex	SPH. .... slotted pan head
HSBH. .... hex socket button head	SQH. .... square head
HSFH. .... hex socket flat head	SRH. .... slotted round head
HSH. .... hex socket head	STD. .... standard
HWH. .... hex washer head	TAP. .... self tapping
HWHTF. .... hex washer head thread forming	TTH. .... torx truss head

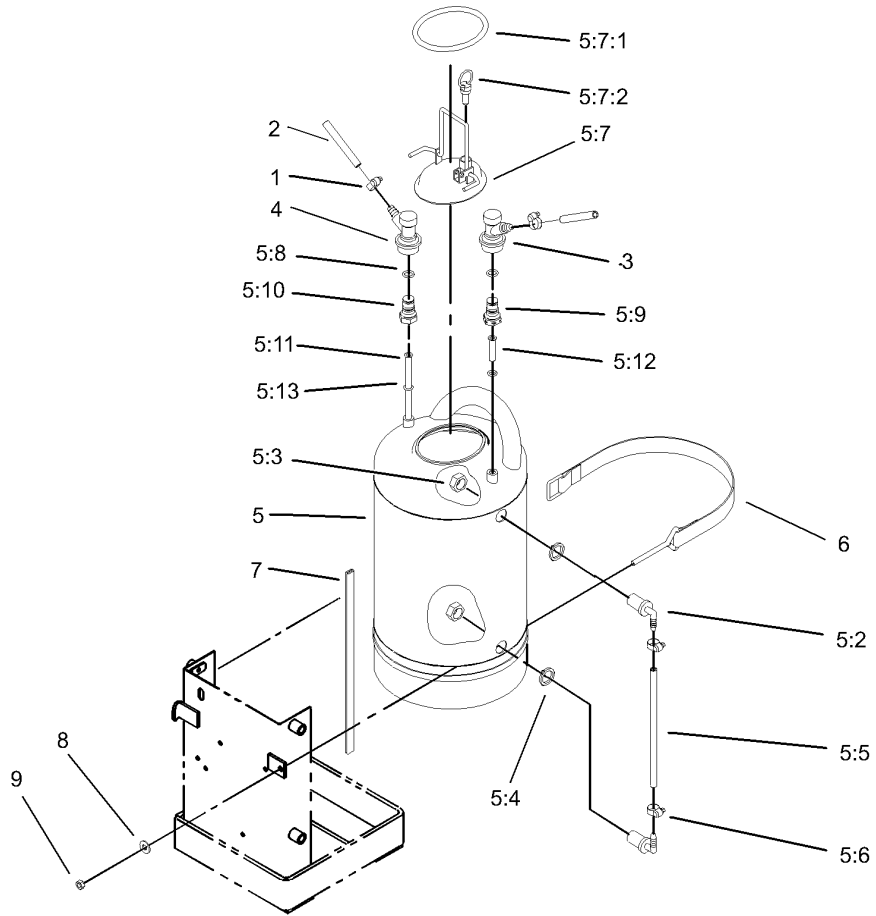

## Sprayer Tank Assembly

Ref	Part No.	Qty.	Description
1	2412-108	2	Clamp-Worm
2	94-7258	2	Hose-Vinyl, Clear
3	94-7193	1	Connector-Quick
4	94-7194	1	Connector-Quick
5	94-7253	1	Tank ASM
5:2	94-7254	2	Barb-Hose
5:3	94-7255	2	Nut-Fitting
5:4	94-7256	2	Washer
5:5	94-7257	1	Hose-Vinyl, Clear
5:6	2412-108	2	Clamp-Worm
5:7	94-8545	1	Lid ASM
5:7:1	94-8544	1	Gasket-Lid
5:7:2	94-8546	1	Valve
5:8	94-8547	2	O-Ring
5:9	94-8548	1	Plug ASM
5:10	94-8549	1	Plug ASM
5:11	94-8550	1	Tube-Inlet
5:12	94-8551	1	Tube-Dip
5:13	94-8552	1	O-Ring
6	762035	1	Strap ASM
7	94-7259	2	Trim
8	3256-2	1	Washer-Flat
9	3296-56	1	Nut-Lock, NI

--	--	--	--

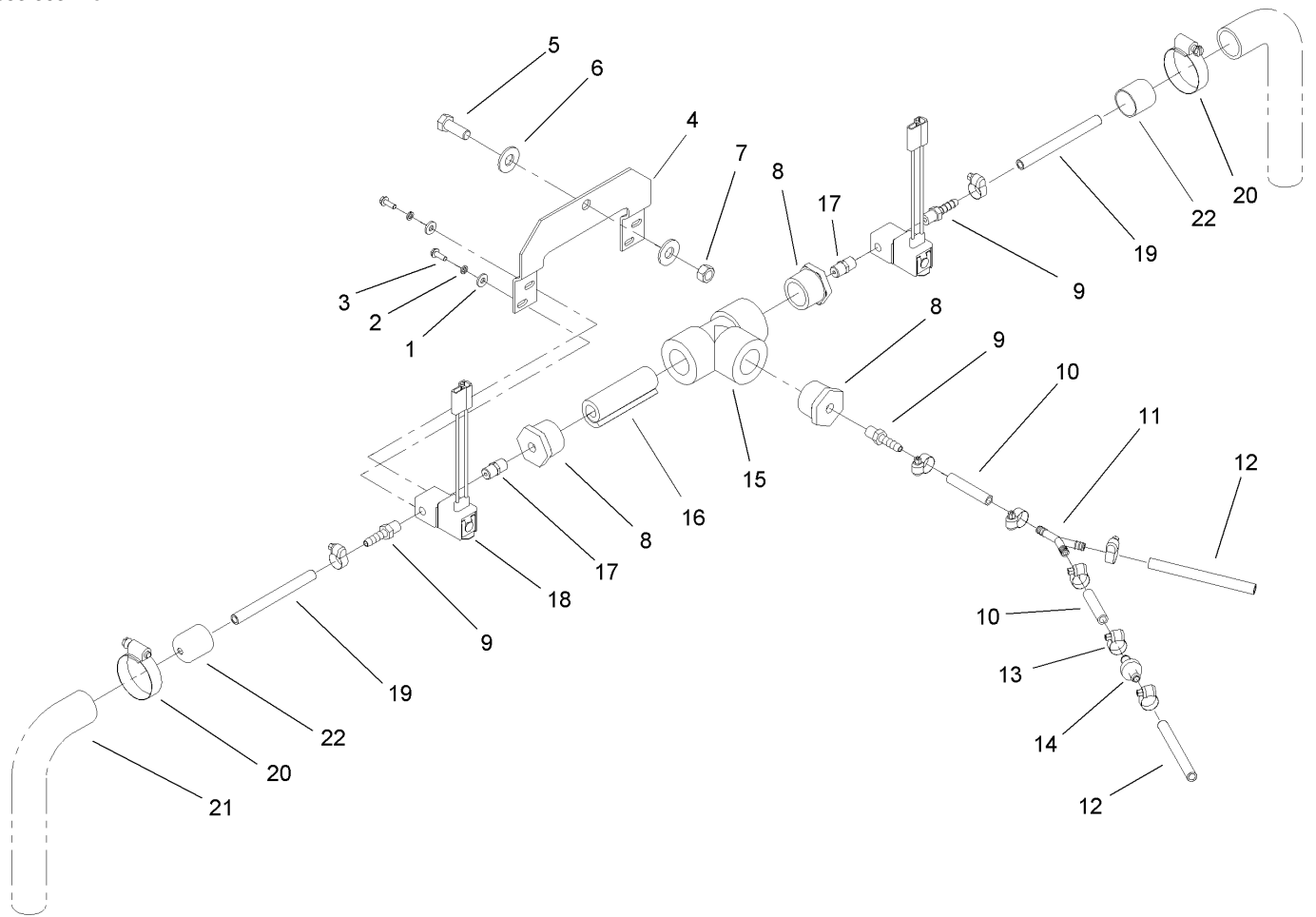

## Valve Assembly

Ref	Part No.	Qty.	Description
1	3256-14	4	Washer-Flat
2	3253-17	4	Washer-Lock / Sp
3	32144-87	4	Screw-Forming, Thread
4	94-7251	1	Bracket-Mixer
5	323-6	1	Screw-HH
6	3256-4	2	Washer-Flat
7	32153-2	1	Nut-Lock, Side
8	94-7225	3	Plug
9	94-7220	3	Hose-Barb
10	94-7250	2	Hose-Vinyl, Clear
11	94-7223	1	Hose-Barb
12	94-7247	2	Hose-Vinyl, Clear
13	2412-108	8	Clamp-Worm
14	94-7196	1	Valve
15	41305	1	Tee
16	94-7227	1	Filter
17	94-7224	2	Nipple
18	94-7191	2	Solenoid Valve ASM
19	94-7248	2	Hose-Vinyl, Clear
20	2412-111	2	Clamp
21	93-0611	2	Extension-Hose
22	94-7195	2	Cap

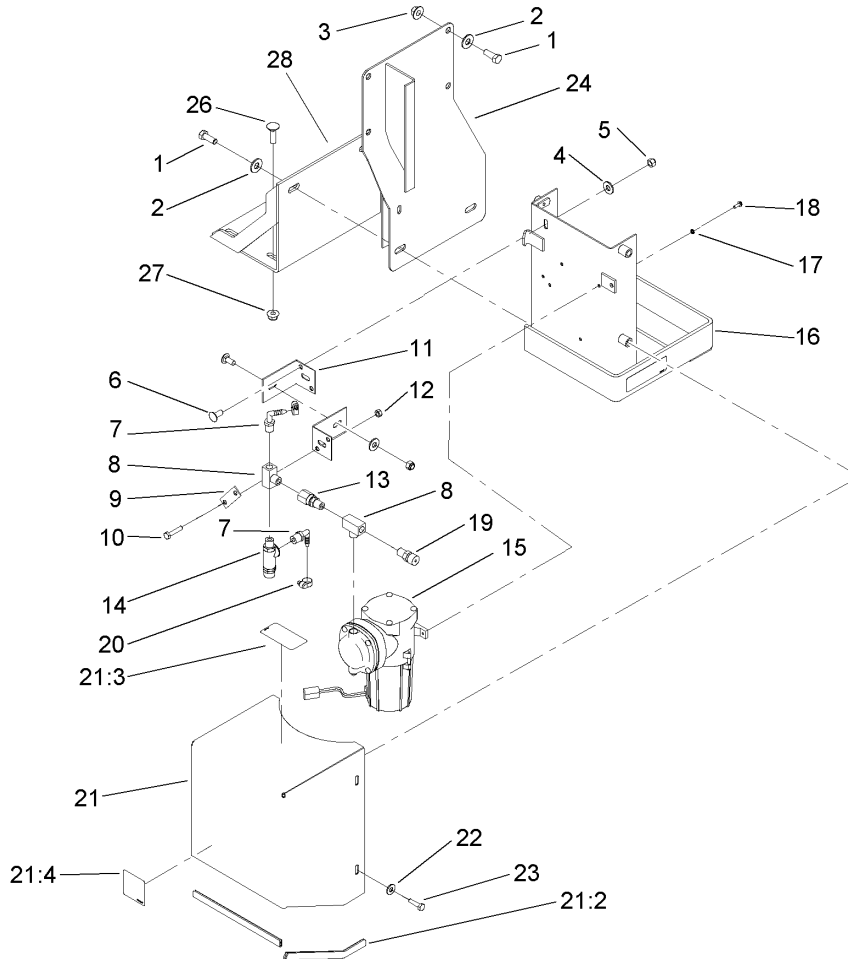

## Frame and Compressor Assembly

Ref	Part No.	Qty.	Description
1	323-6	4	Screw-HH
2	3256-4	4	Washer-Flat
3	32128-43	2	Nut-Flange
4	3256-3	2	Washer-Flat
5	3296-29	2	Nut-Lock, NI
6	3230-23	2	Screw-CARR
7	94-7221	2	Barb-Hose
8	94-7219	2	Fitting-Tee
9	94-7268	1	Strap-Support
10	321-8	2	Screw-HH
11	94-7267-03	2	Bracket-Support
12	3296-56	2	Nut-Lock, NI
13	94-7199	1	Valve-Check, Inline
14	94-7198	1	Valve-Relief, Side Outlet
15	94-7200	1	Compressor ASM
16	94-7260-03	1	Tank Bracket ASM
17	3253-17	3	Washer-Lock / Sp
18	32144-87	3	Screw-Forming, Thread
19	94-7197	1	Valve-Relief
20	2412-108	2	Clamp-Worm
21	106-1044	1	Cover ASM
21:2	106-1043	3	Trim-Strip
21:3	94-7275	1	Decal-Valve, Relief
21:4	94-7287	1	Decal-Valve, Adjustment

Ref	Part No.	Qty.	Description
22	3256-2	4	Washer-Flat
23	321-6	4	Screw-HH
24	106-1296-03	1	Foam Marker Bracket ASM
26	3231-25	4	Screw-CARR
27	104-8301	4	Nut-Flange, NI
28	108-3561-03	1	Bracket ASM



