



**Pro Control™ Spray System**  
**For the Multi-Pro® 5600 & 5700-D Turf Sprayer**  
Model No. 41086—Serial No. 23000001 and Up

**Operator's Manual**

# Contents

Introduction .....	2
Safety .....	2
Setup .....	3
Installing the Console Computer .....	3
Mounting the Flowmeter .....	3
Closing the Boom Valves .....	4
Operation .....	4
Controls .....	5
The Console Keys .....	5
Keypad Reference Table .....	6
Initially Programming the Console Computer .....	7
Programming the Console Computer .....	7
Self-Testing the Console Computer .....	10
Activating the Data Lock .....	10
Changing the Data Lock .....	10
Entering the Mode Sequence with the Data Lock Activated .....	10
Setting the Power Down Delay Time .....	10
Using the Console Computer Alarm .....	10
Setting the Low Limit Flow Set Point and Low Limit Alarm .....	10
Setting Up the System .....	11
Initially Field-testing the System .....	11
Maintenance .....	12
Cleaning the Flowmeter .....	12
Calibrating the Flowmeter .....	12
Troubleshooting .....	13
Testing the Flowmeter Cable .....	15

## Introduction

Read this manual carefully to learn how to operate and maintain your product properly. The information in this manual can help you and others avoid injury and product damage. Although Toro designs and produces safe products, you are responsible for operating the product properly and safely.

Whenever you need service, genuine Toro parts, or additional information, contact an Authorized Distributor or Toro Customer Service and have the model and serial numbers of your product ready. The model and serial numbers are on the back of the product.

Write the product model and serial numbers in the space below:

<b>Model No.</b> _____ <b>Serial No.</b> _____
---

This manual identifies potential hazards and has special safety messages that help you and others avoid personal injury and even death. **Danger**, **Warning**, and **Caution** are signal words used to identify the level of hazard. However, regardless of the hazard, be extremely careful.

**Danger** signals an extreme hazard that **will** cause serious injury or death if you do not follow the recommended precautions.

**Warning** signals a hazard that **may** cause serious injury or death if you do not follow the recommended precautions.

**Caution** signals a hazard that may cause minor or moderate injury if you do not follow the recommended precautions.

This manual uses 2 other words to highlight information.

**Important** calls attention to special mechanical information and **Note**: emphasizes general information worthy of special attention.

## Safety

**Read and understand the contents of this manual before operating the console computer.**

**▲ This is the safety alert symbol. It is used to alert you to potential personal injury hazards. Obey all safety messages that follow this symbol to avoid possible injury or death.**

- Keep this Operator's Manual with the *Operator's Manual* for the Multi Pro® 5600 or 5700-D Turf Sprayer.
- It is very important that all who operate this equipment have ready access to these instructions at all times.
- Read these instructions and the instructions in the *Operator's Manual* for the Multi Pro® 5600 or 5700-D Turf Sprayer carefully. Be familiar with the controls and the proper use of the equipment.
- Never allow children or people unfamiliar with these instructions to use the controls.
- Never spray while people, especially children, or pets are nearby.
- Chemicals can injure people, animals, plants, soils, or other property. To avoid personal injury and environmental damage:
  - Select the proper chemicals for the job.

- Follow the manufacturer's instructions on the chemical container labels. Apply and handle chemicals as recommended.
  - Handle and apply the chemicals with care.
  - Wear all necessary protective equipment.
  - Handle chemicals in well-ventilated areas.
  - Never smoke when handling chemicals.
  - Properly dispose of unused chemicals and containers.
- Keep in mind that the operator or user is responsible for accidents or hazards occurring to other people or for damage to property.

# Setup

## Installing the Console Computer

1. Remove the knockout plug in the dashboard and insert the large grommet (Fig. 1).

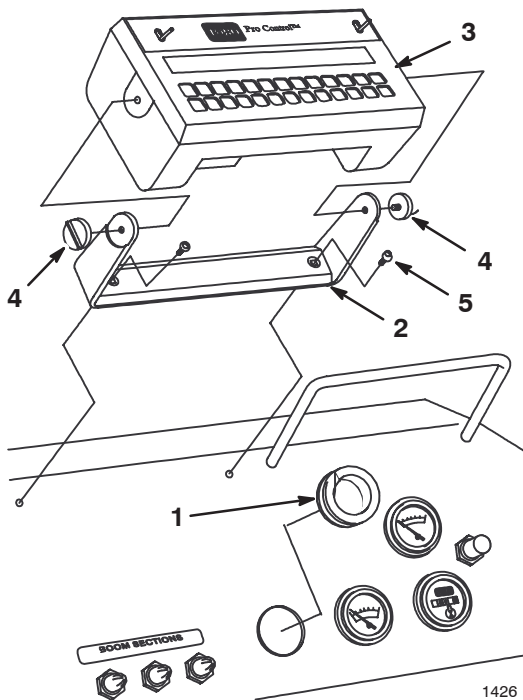

**Figure 1**

- |                     |                          |
|---------------------|--------------------------|
| 1. Large grommet    | 4. Mounting knobs        |
| 2. Mounting bracket | 5. Flange head screw (2) |
| 3. Console computer |                          |

2. Remove the mounting bracket from the console computer and secure the mounting bracket to the dashboard with 2 flange head screws (Fig. 1).

3. Cut the plastic tie that secures the console computer wiring harness under the dashboard.
4. Remove the 2 protective caps from the cable ends.
5. Insert the console control cable and speed sensor cable from under the dashboard through the hole with the large grommet.
6. Plug the cables into their proper receptacles in the rear of the console computer.
7. Secure the cables to the console computer by rotating the locking rings.
8. Attach the console computer to the mounting bracket and secure it with the 2 mounting knobs (Fig. 1).

## Mounting the Flowmeter

1. Disconnect the boom supply hose fitting from the boom valve assembly (Fig. 2).

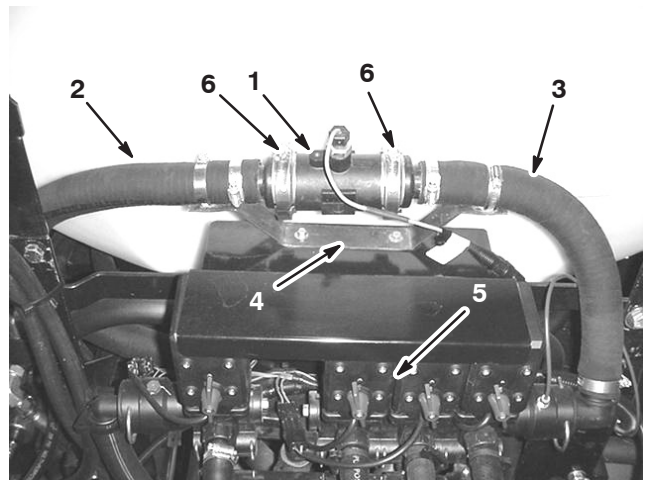

**Figure 2**

- |                                       |                               |
|---------------------------------------|-------------------------------|
| 1. Flowmeter                          | 4. Flowmeter mounting bracket |
| 2. Boom supply hose (longer section)  | 5. Boom valve assembly        |
| 3. Boom supply hose (shorter section) | 6. Worm gear screw clamp      |

2. Disconnect the boom supply hose fitting from the tee located behind the boom valve assembly.

3. Measure, mark, and cut the supply hose as shown in Figure 3.

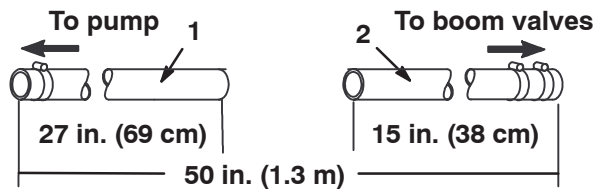

Figure 3

1. Longer supply hose section
2. Shorter supply hose section

! **Caution** !

**Many chemicals are hazardous and can cause personal injury or environmental damage if you apply them improperly.**

**Ensure that sprayer hose connections are secure before operating the sprayer system.**

4. Install a barbed fitting into the end of the longer supply hose section and secure it with a hose clamp next to the fitting body.

**Important** Apply liquid soap to the barbed fitting to lubricate it. You must install the hose all the way onto the barb. Do not use petroleum-based lubricants such as grease or oil because they can damage the hose and contaminate the system.

5. Attach the fitting on the end of the longer supply hose section to the tee.
6. Attach the fitting on the end of the shorter supply hose section to the boom valve assembly.
7. Attach the flowmeter bracket to the rear of the boom valve mounting bracket using 2 flange head screws (1/4 in.) and flange nuts.
8. Assemble the gaskets and barbed fittings on the hoses to the flowmeter using 2 worm screw clamps (Fig. 2).

**Important** Note the direction of the flow on the side of the flowmeter and ensure that the flowmeter is installed properly (Fig. 2).

9. Secure the flowmeter to the hoses with 2-inch worm screw clamps.
10. Secure the supply hoses to the flowmeter mounting bracket with 2 hose clamps (Fig. 2).
11. Install a barbed fitting into the end of the shorter supply hose section and secure it with a hose clamp next to the fitting body.
12. Connect the plug from the flowmeter to its mate plug in the wiring harness.

## Closing the Boom Valves

This system is designed to work with a diaphragm pump and must operate with the boom bypass valves closed.

**Important** Before operating the spray system with the console computer, close all bypasses on your boom valves by turning in the red adjustment knob at the bottom of the boom valves clockwise as far as possible.

## Operation

The console computer automatically controls the spray application rate for varying vehicle speeds. You set the target volume per unit area to spray and the console computer automatically maintains the flow within the proper range of the vehicle speed and continually displays the actual volume of material per area sprayed. The console computer also monitors the area sprayed, the speed of the vehicle, and the total volume of material sprayed.

**Important** A manual override switch allows the operator to manually control the flow for the system check out and spot spraying.

**Note:** If the console computer malfunctions, you can spray manually by unplugging the cables from the rear of the console computer. You can then control the spray application rate using the center console controls.

**Note:** In this section, the procedure will use the following naming convention:

- The labels on the console computer keys are enclosed in brackets. For example: Press the [Enter] key.
- The data you enter is in boldface type preceded by the word **Press**. For example: Press **123**.
- The data shown in the display is in normal type, with letters in all caps.

## Controls

The Pro-Control™ System consists of a computer-based control console, a speed sensor, and a turbine-type flowmeter.

Become familiar with the controls (Fig. 4) before you start the engine and operate the sprayer.

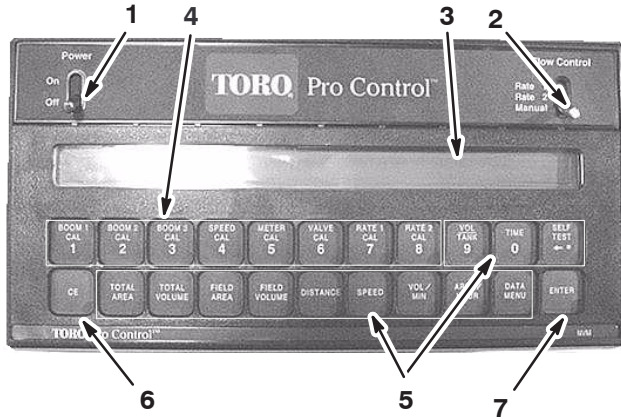

Figure 4

- |                        |                  |
|------------------------|------------------|
| 1. Power switch        | 5. Function keys |
| 2. Flow control switch | 6. CE key        |
| 3. Display             | 7. Enter key     |
| 4. Calibration keys    |                  |

### Power switch

This switch turns the console power on and off. Turning off the console computer does not affect the data stored in the computer.

### Flow control switch

This switch allows you to automatically or manually control the spray system. There are 2 automatic positions and 1 manual position.

## The Console Keys

The keypad for the console computer is shown in Figure 5.

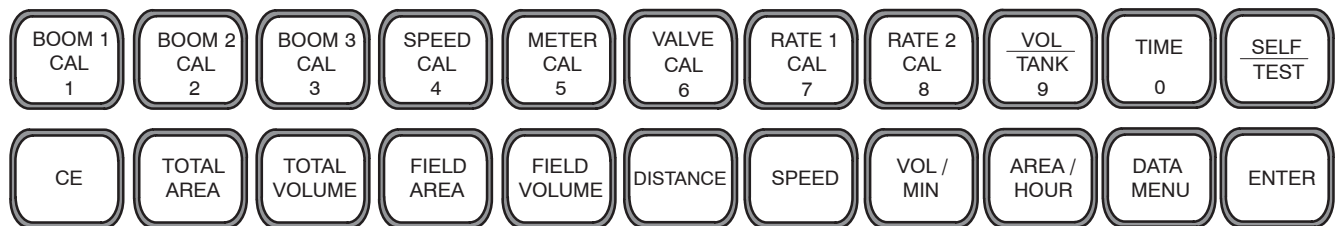

Figure 5

## Display

The display shows the function and calibration data.

### Calibration keys

These keys allow the operator to enter data into the console computer to calibrate the spray system.

### Function keys

These keys display needed data, such as the total area sprayed, the total volume of material sprayed, the vehicle speed, and the volume of material remaining in the tank.

### Enter key

This key allows you to enter data into the console computer.

### CE key

This key clears the data shown in the display; it also enables you to toggle through the options found in certain function keys.

**Important** The console computer allows the following parameters:

- Area: US (acres); SI (hectares) or TU (1000 ft<sup>2</sup>)
- Speed sensor type: SP1 (wheel drive, etc.), SP2 (radar), or SP3. This system uses the SP3 gear tooth sensor. Refer to Initially Programming the Console Computer on page 7.

## Keypad Reference Table

Key	Description	Value	Function <sup>1</sup>
BOOM 1 CAL	Length of boom 1	1	It calculates the length of the boom by multiplying the number of nozzles by the spacing between them in inches (cm) of the left boom. Enter <b>80</b> inches ( <b>204</b> cm) as the default.
BOOM 2 CAL	Length of boom 2	2	It calculates the length of the boom by multiplying the number of nozzles by the spacing between them in inches (cm) of the center boom. Enter <b>60</b> inches ( <b>152</b> cm) as a default.
BOOM 3 CAL	Length of boom 3	3	It calculates the length of the boom by multiplying the number of nozzles by the spacing between them in inches (cm) of the right boom. Enter <b>80</b> inches ( <b>204</b> cm) as a default.
SPEED CAL	Speed calibration number	4	It enables you to verify that the vehicle distance readout is accurate. Enter <b>148</b> as a starting point for all Toro sprayers.
METER CAL	Flowmeter calibration number	5	Enter the number found on the flowmeter label or the tag on the flowmeter cable.
VALVE CAL	Control valve response time	6	It sets the system response. Enter <b>023</b> as a starting point. Note: <b>0</b> does not display but you must enter it.
RATE 1 CAL	Target application rate 1	7	It is the first application rate.
RATE 2 CAL	Target application rate 2	8	It is the second application rate. If there is only one application rate, use the Rate 1 value again.
VOL / TANK	Volume of material remaining in the tank	9	It displays the volume of material in the sprayer tank. Reset the volume when you refill the tank.
TIME	24-hour clock	0	It is a 24 hour clock or an elapsed timer. You reset it when you turn off the console computer.
SELF TEST	Simulation of vehicle speed	Back space	It simulates the vehicle speed to allow the operator to check and calibrate the system operation.
CE	Clear entry		It clears a wrong entry; enables you to toggle between settings during initial programming; and enables you to select functions and settings.
TOTAL AREA	Total area sprayed		It monitors the total area until you clear it to zero.
TOTAL VOLUME	Total volume of material sprayed		It monitors the volume of material sprayed until you clear it to zero.
FIELD AREA	Field area sprayed		It monitors the total area covered until you clear it to zero.
FIELD VOLUME	Volume of material sprayed onto a field or specific area		It monitors the volume of material applied until you clear it to zero.
DISTANCE	Distance of vehicle travel		It measures the distance the vehicle travels until you clear it to zero.
SPEED	Vehicle speed		It displays the vehicle speed.

Key	Description	Value	Function <sup>1</sup>
VOL / MIN	Volume of material sprayed per minute at vehicle speed		It displays the volume/minute that the system is currently using.
AREA / HOUR	Area sprayed per hour at vehicle speed		It displays acres, 1000 sq. ft., or hectares covered per hour at the vehicle speed driven.
DATA / MENU	Adjusting the agitation and monitoring the hose reel and other options		It allows you to adjust the agitation. Note: When the number increases, the agitation pressure increases. The number is <b>not</b> the agitation pressure. It also allows you to use additional devices, such as a data loggers and global positioning systems (GPS).
ENTER	Enter data		It allows you to enter data into the console computer.

<sup>1</sup>The calibration numbers listed are **for reference only**. Before spraying, check your sprayer to ensure the numbers you are using are correct.

## Initially Programming the Console Computer

You must first program the console computer before you can use it to operate the spray system. You need to perform this operation only when you turn on the console computer for the first time.

Turn the power switch to the On position.

**Note:** The console screen shows the message CAL in the display.

### Selecting US, SI, or TU

To select the units for US (volume per acre), SI (volume per hectare), or TU (volume per 1,000 sq. ft.):

1. Press the [CE] key until you see your desired code (US, SI, TU) in the display.
2. Press the [Enter] key.

The display now shows SP1.

**Note:** If you make a data entry error, reset the console computer by turning the power switch to the Off position and, while pressing and holding the [CE] key, turning the power switch to the On position.

### Selecting SP3

1. Press the [CE] key until you see SP3.

**Note:** SP1 is for wheel drive and SP2 is for radar speed drive and are not used. For your console computer, the SP3 (gear tooth drive) is the proper setting.

2. Press the [Enter] key.

**Note:** The display shows 0.

3. To program the computer console, refer to Programming the Console Computer on page 7.

**Note:** All the data is retained when you turn the power switch to the Off position.

## Programming the Console Computer

**Important** Ensure that the boom bypass valves are closed.

Move the power switch on the console computer to the On position.

**Note:** Turning the power switch to the Off position or disconnecting the console cables does not erase the data stored in the console computer memory.

**Important** The calibration figures given are guidelines only; you should perform calculations for your particular machine and spraying application situation and conditions.

**Note:** Refer to Figure 5 and the Keypad Reference Table on page 6 for the description and function of the keys on the console computer.

### Calculating the Boom Cal Data

Calculate the Boom Cal by multiplying the number of spray tips by the tip spacing.

**Note:** Boom 1 is the left boom (from the operating position), Boom 2 is the center boom, and Boom 3 is the right boom.

1. Press the [Boom 1 Cal] key.

2. Press the [Enter] key.
3. Enter **80**.
4. Press the [Enter] key.
5. Press the [Boom 2 Cal] key.
6. Press the [Enter] key.
7. Enter **60**.
8. Press the [Enter] key.
9. Press the [Boom 3 Cal] key.
10. Press the [Enter] key.
11. Enter **80**.
12. Press the [Enter] key.

## Entering the SPEED Cal Number

The SPEED Cal number is critical to the performance of the spray system. Ensure that the tires are properly inflated and that the tank is half full before performing this procedure.

1. Press the [Speed Cal] key.
2. Press the [Enter] key.
3. Enter **148**.
4. Press the [Enter] key.
5. Measure 500 feet on a flat ground surface.
6. Set the distance readout to **0**.
7. Press the [Distance] key.
8. Press the [Enter] key.
9. Enter **0**.
10. Press the [Enter] key.
11. Drive the vehicle 500 feet.
12. Ensure that the distance readout on the console computer reads between 490 and 510 feet.
13. If the readout is not between 490 and 510 feet, calibrate the SPEED Cal using the following equation:  
New SPEED Cal number =  $148 \times 500 / \text{Distance readout}$
14. Enter the new Speed Cal number using steps 1 through 4.

## Entering the Meter Cal Number

Use the gallon calibration number for U.S. gallons per acre or U.S. gallons per 1000 sq. ft. or a liter calibration number for liters per hectare.

1. Press the [Meter Cal] key.
2. Press the [Enter] key.
3. Enter the Meter Cal calibration number.

**Note:** The Meter Cal (or flowmeter) calibration number is stamped on the tag attached to the flowmeter or meter cable.

4. Press the [Enter] key.

## Entering the Valve Cal Number

The Valve Cal number controls the response of the hydraulic control valve to change the vehicle speed. This number consists of three digits: the valve speed digit, the brake point digit percent, and the dead=band digit. For example, for the Valve Cal number of 023, the valve speed digit is 0, the brake point digit percent is 2, and the dead=band digit is 3.

- Valve speed digit

This digit controls the response time of the control valve motor.

**Important** Running the control valve too fast (a number greater than zero) will cause the system to oscillate.

Range: 0 (slow) to 9 (fast)

### Brake point digit percent

This digit sets the point at which the control valve motor begins to brake to prevent the system from overshooting the application rate. The digit is the percent away from the target rate.

Range: 0 (0%) to 9 (90%); each value represents a multiple of 10%

### Dead=Band digit

Range: 0 (0%) to 9 (9%)

This digit is the difference between the target and the actual application rate, where the rate correction is not performed.

To enter the Valve Cal number:

1. Press the [Valve Cal] key.
2. Press the [Enter] key.
3. Enter the Valve Cal calibration number.

**Note:** The initial valve calibration number for Valve Cal is **023**. We recommend that you use this number for most spray applications; **063** may be helpful for small application rates.

4. Press the [Enter] key.

## Entering Rate 1 and Rate 2 Data

Enter the spray application rate (with decimal) in Rate 1 and Rate 2. Enter the rates in U.S. gallons per acre (US mode), U.S. gallons per 1,000 square feet (TU mode), or liters per hectare (SI mode) depending on the base measurement you select.

1. Press the [Rate 1 Cal] key.
2. Press the [Enter] key.
3. Enter the target application rate (in gal. per acre, liters per hectare, or U.S. gallons per 1,000 sq. feet) that you want to spray.
4. Press the [Enter] key.
5. Press the [Rate 2 Cal] key.
6. Press the [Enter] key.
7. Enter a second target application rate (in U.S. gallons per acre, liters per hectare, or U.S. gallons per 1,000 sq. ft.) that you want to spray, if you desire.

**Note:** Rate 2 should not differ more than 20% from Rate 1. If you do not use a second rate, enter the same rate for Rate 1 and Rate 2.

8. Press the [Enter] key.

**Note:** You have now completed programming the console computer. The flashing CAL in the display should stop. If not, repeat the procedures for programming the console computer.

## Entering Optional Calibration Values

You may also want to enter the following data, but it is not required for operating the spray system.

### Volume Tank

This number represents the volume of material in the tank and must be entered each time you refill the tank. The function monitors the tank volume while you are spraying based on the total amount applied.

1. Press the [Vol/Tank] key.
2. Press the [Enter] key.
3. Enter the amount of material in the tank.
4. Press the [Enter] key.

### Time

Enter the time of day based on a 24-hour day. For example, 1:30 p.m. is 13:30. You can also enter 0 to measure elapsed time.

To set the date, do the following:

1. Press the [Time] key.

The display shows MONTH.

2. Press the [Enter] key to change the month.
3. Press the [Time] key.  
The display shows DAY.
4. Press the [Enter] key to change the day.
5. Press the [Time] key.  
The display shows YEAR.
6. Press the [Enter] key to change the year.
7. Press the [Time] key.  
The display shows POWER DOWN DAY.

## Displaying Data

To display the following data, do the following:

### Total Area

Press the [Total Area] key.

### Total Volume

Press the [Total Volume] key.

**Note:** To change the total volume to 0, enter 0.

### Field Area

Press the [Field Area] key.

### Field Volume

Press the [Field Volume] key.

**Note:** To change the total volume to 0, enter 0.

### Distance

Press the [Distance] key.

**Note:** The distance is displayed in meters. To change the total volume to 0, enter 0.

### Speed

Press the [Speed] key.

### Vol/Min

Press the [Vol/Min] key.

### Area/Hour

Press the [Area/Hr] key.

### US, TI, TU, SP1, SP2, or SP3

Press and hold the [Self Test] key.

**Note:** These parameters will alternately appear on the display.

## Data Menu

You use this key when you attach additional devices such as a data logger or a GPS. Refer to the operating manuals for these devices for how to program them.

**Note:** Do not change the other values for the PWM (pulse width modulation); they are preset for the system.

## Self-Testing the Console Computer

The self test allows you to simulate the speed for testing the system when the vehicle is not moving.

1. Press the [Self Test] key.
2. Enter the speed in mph or km/h.
3. Press the [Enter] key.
4. Press the [Speed] key to verify the speed.

The speed shows in the display.

**Note:** The self test speed will clear itself when the speed sensor detects that the vehicle is moving.

## Activating the Data Lock

This is an optional feature that prohibits users from entering data without first entering the data lock code.

1. Press [Data Menu] several times until you see PRESS ENTER FOR DATA LOCK on the display.
2. Enter a 4-digit code and press the [Enter] key within 15 seconds.

## Changing the Data Lock

1. Press the [Data Menu] key several times until you see the PRESS ENTER FOR DATA LOCK in the display.
2. Press the [Enter] key.  
**Note:** The display shows OLD CODE E.
3. Enter a 4-digit code and press the [Enter] key within 15 seconds.
4. Press the [Enter] key.

## Entering the Mode Sequence with the Data Lock Activated

1. Press the key in which you wish to enter day.
2. Press the [Enter] key.

The display shows CODE.

3. Enter your data lock code.

If the code is correct, the display will show an E.

4. Enter your data as you normally do.

**Note:** You may clear the data lock code by entering a code of 0 by resetting the console. Set the power switch to the Off position and hold the [CE] key down while you set the power switch to the On position.

## Setting the Power Down Delay Time

To conserve the 12-volt battery on the vehicle, set the power down delay. In this power down mode, all the data is retained but the time of day clock does not operate. The power down day is initially set to 10 days.

1. Press the [Time] key 5 times.

The display shows POWER DOWN DAY.

2. Press the [Enter] key.
3. Change the power down day setting.
4. Press the [Enter] key.

## Using the Console Computer Alarm

This is an optional feature.

The console alarm sounds if the application rate is 30% or more away from the target application rate for 5 seconds.

1. Press the [Data Menu] key several times.

The display shows ALARM ON. The alarm is enabled.

2. Press the [CE] key.

The display shows ALARM OFF. The alarm is disabled.

## Setting the Low Limit Flow Set Point and Low Limit Alarm

This is an optional feature.

If the actual volume per minute falls below this limit, the control valve stops closing, the alarm sounds, and the display flashes –LL–. Determine the low limit value with all the booms on. This value is automatically proportional to the percentage of booms that are on. For example, if the entered low limit is 4 gal./min. and half of the total boom length is shut off, the console automatically reduces the low limit to 2 gal./min.

## Setting Up the System

Before operating the spray system, perform this procedure.

1. Attach the supply hose to the anti-siphon tube and fill the tank half full of clean water.

**Important** Inspect and clean all system components before spraying, including the tank, strainer, pump, valves, and nozzles.

2. Start the engine; refer to the *Operator's Manual* for the Multi-Pro® 5600 or 5700-D Turf Sprayer.
3. Move the throttle lever to the maximum setting to simulate the desired spraying speed.
4. Turn the Boom On/Off switches to the Off position.
5. Turn the Man/Rate switch to Man.
6. Turn the Power On/Off switch to the On position.
7. Turn the Spray Pump Control switch to the On position.
8. Ensure that you have entered the proper values for the correct boom width and calibrations for Speed Cal, Meter Cal, Valve Cal, Rate 1, and Rate 2.
9. Use the self-test feature as described in the *Operator's Manual* for the Multi-Pro™ 5600 or 5700-D Turf Sprayer for testing the spray system while the vehicle is not moving.

**Note:** You must enter a value for the speed in order for the pump to run with the controller in any mode (Rate 1, Rate 2, or Manual).

10. Turn the Boom switches to the On position.

**Note:** If the switch lights don't light, the foot switch is off. Turn the foot switch to the On position.

11. Use the Pressure Adjust switch to increase the pressure to 20 psi, then decrease it back to 0 psi.

12. Turn the Man/Rate switch to Rate 1.

**Note:** The pump should increase the pressure until it reaches the desired rate.

13. Turn the Master Boom Control (foot) switch to the Off position.

**Note:** The system stops the pump.

14. Turn the Agitation switch to the On position.

**Note:** The system starts the pump and increases the pump speed until the pump reaches the preset agitation pressure. The system goes to this pressure when the booms are off and the pump and agitation are on.

15. Turn the Agitation switch, and the Pump switch to the Off position.

## Initially Field-testing the System

Before operating the spray system, perform this procedure.

1. Drive the vehicle at the desired spraying speed with the sprayer booms off.
2. Press the [Speed] key to verify the speed readout.
3. Turn the Spray pump control switch to Rate 1.
4. Turn the Power switch to the On position.
5. Turn the Foot switch to the On position.

**Note:** Use the Foot switch when all the booms are to be turned on.

6. Ensure that the Boom 1, Boom 2, and Boom 3 switches are in the On position.
7. Set the Man/Rate switch to Rate 1.
8. Increase or decrease the vehicle speed by 1 mph (2 km/h).

**Note:** The system should automatically correct the target application rate. If the system is not correcting the application rate, review the Initial System Setup; then refer to Troubleshooting.

9. After spraying a swath, switch the foot switch to the Off position to shut off the spray flow to all booms.

**Note:** This also shuts off the acreage totalizer.

10. Verify the area covered and the volume of material sprayed.

# Maintenance

## Cleaning the Flowmeter

Once every season, flush out and clean the flowmeter. Flush out and clean it more often if you are spraying wettable powders.

1. Thoroughly rinse and drain the entire spraying system.
2. Remove the flowmeter from the sprayer and flush it with clean water.
3. Remove the retainer ring on the upstream side (Fig. 6).

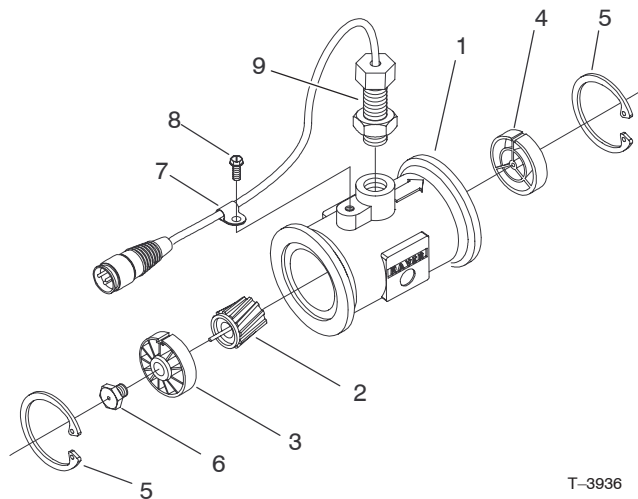

**Figure 6**

- |                                  |                          |
|----------------------------------|--------------------------|
| 1. Modified flanged body         | 6. Turbine stud assembly |
| 2. Rotor/ magnet assembly        | 7. Cable clamp           |
| 3. Hub/ bearing assembly         | 8. Thread screw          |
| 4. Hub assembly (with keyway up) | 9. Sensor assembly       |
| 5. Retaining ring                | 10. Flow-reducing sleeve |

4. Clean the turbine and the turbine hub to remove metal filings and any wettable powders.

5. Inspect the turbine blades for wear.

**Note:** Hold the turbine in your hand and spin it. It should spin freely with very little drag. If it does not, replace it.

6. Assemble the flowmeter.

7. Use a low pressure (5 psi or 50 kPa) air jet to ensure that the turbine spins freely. If it does not, loosen the hex stud on the bottom of the turbine hub by 1/16 of a turn until the turbine spins freely.

## Calibrating the Flowmeter

1. Press the [Meter Cal] key.
2. Enter the Meter Cal number.

**Note:** The Meter Cal (or flowmeter) calibration number is stamped on the tag attached to the flowmeter or meter cable.

3. Press the [Enter] key.
4. Press the [Total Volume] key.
5. Press the [Enter] key.
6. Enter 0.
7. Press the [Enter] key.
8. Fill the tank with a predetermined amount of water.

**Note:** For best results, measure the water using an independent method. For the best accuracy, determine the amount of water ahead of time so that the applicator tank is full.

9. Empty the tank by boom spraying under normal conditions.

**Note:** The vehicle does not need to be in motion to perform this step.

10. After emptying the water from the tank, check the Total Volume number. This number should equal the predetermined amount of water. If it is not, calculate the Meter Cal number using the formula that follows. Under normal conditions, the Meter Cal number should be within +/- 3% of the number stamped on the tag of the flowmeter.

See the example below:

Meter Cal (from tag) = 1660

Total Volume = 103

Amount of water = 100

$$\begin{aligned} \text{Corrected} \\ \text{Meter Cal} &= \frac{\text{Meter Cal} \times \text{Total Volume}}{\text{Amount of water}} \\ &= \frac{1660 \times 103}{100} = 1710 \end{aligned}$$

Corrected Meter Cal = 1710.

**Note:** Repeat this procedure several times to confirm that the corrected Meter Cal number is accurate.

# Troubleshooting

**Note:** If the console computer malfunctions or needs repair, you can resume spraying in manual mode by unplugging the cables from the rear of the console computer. You can then control the system using the center console controls.

<b>Problem</b>	<b>Possible Causes</b>	<b>Corrective Action</b>
No display lights with the power on	<ol style="list-style-type: none"> <li>1. The fuse on the back of the console computer is blown.</li> <li>2. The battery connections are loose.</li> <li>3. The power switch is not operating properly.</li> <li>4. There is a problem with the processor board assembly.</li> </ol>	<ol style="list-style-type: none"> <li>1. Replace the fuse.</li> <li>2. Secure the battery connections.</li> <li>3. Repair or replace the power switch.</li> <li>4. Have an Authorized Distributor replace the processor board assembly.</li> </ol>
All keyboard lights are on at the same time	<ol style="list-style-type: none"> <li>1. There is a problem with the face plate sub assembly.</li> </ol>	<ol style="list-style-type: none"> <li>1. Have an Authorized Distributor replace the face plate sub assembly.</li> </ol>
You cannot enter a digit using the keyboard	<ol style="list-style-type: none"> <li>1. There is a problem with the face plate sub assembly.</li> </ol>	<ol style="list-style-type: none"> <li>1. Have an Authorized Distributor replace the face plate sub assembly.</li> </ol>
An indicator on a key does not illuminate	<ol style="list-style-type: none"> <li>1. There is a problem with the face plate sub assembly.</li> </ol>	<ol style="list-style-type: none"> <li>1. Have an Authorized Distributor replace the face plate sub assembly.</li> </ol>
The console computer displays a flashing Cal whenever you start the engine	<ol style="list-style-type: none"> <li>1. The battery connections are loose.</li> <li>2. The battery is not providing sufficient voltage.</li> </ol>	<ol style="list-style-type: none"> <li>1. Secure the battery connections.</li> <li>2. Check the battery voltage.</li> </ol>
The console computer displays a flashing Cal whenever you turn the master switch to the On or Off position	<ol style="list-style-type: none"> <li>1. The battery connections are loose.</li> <li>2. The battery is not providing sufficient voltage.</li> </ol>	<ol style="list-style-type: none"> <li>1. Secure the battery connections.</li> <li>2. Check the battery voltage.</li> </ol>
The console computer displays a flashing Cal whenever you change the speed	<ol style="list-style-type: none"> <li>1. The battery connections are loose.</li> <li>2. The battery is not providing sufficient voltage.</li> </ol>	<ol style="list-style-type: none"> <li>1. Secure the battery connections.</li> <li>2. Check the battery voltage.</li> </ol>
One display digit has one or more missing segments	<ol style="list-style-type: none"> <li>1. There is a problem with the LCD display board assembly.</li> </ol>	<ol style="list-style-type: none"> <li>1. Have an Authorized Distributor replace the LCD display board assembly.</li> </ol>
The speed display reads 0	<ol style="list-style-type: none"> <li>1. The pins on the speed sensor cable connector and the plug on the back of the console computer are loose.</li> <li>2. The pins and the sockets on the speed sensor cable are dirty.</li> <li>3. There is a problem with the speed sensor switch assembly.</li> </ol>	<ol style="list-style-type: none"> <li>1. Have an Authorized Distributor repair or replace the connector or the plug on the back of the console computer.</li> <li>2. Clean the pins and sockets on the speed sensor cable connectors.</li> <li>3. Have an Authorized Distributor replace the speed sensor switch assembly.</li> </ol>

<b>Problem</b>	<b>Possible Causes</b>	<b>Corrective Action</b>
The speed is inaccurate or unstable	<ol style="list-style-type: none"> <li>1. The wheel drive setting is not set to SP3.</li> <li>2. The Speed Cal number is incorrect.</li> </ol>	<ol style="list-style-type: none"> <li>1. Set the wheel drive setting to SP3.</li> <li>2. Enter the correct Speed Cal number.</li> </ol>
The rate reads 0000	<ol style="list-style-type: none"> <li>1. The Speed Cal is zero.</li> <li>2. The wheel drive setting is not set to SP3.</li> <li>3. The Total Volume is not registering the flow.</li> </ol>	<ol style="list-style-type: none"> <li>1. Enter the correct Speed Cal number.</li> <li>2. Set the wheel drive setting to SP3.</li> <li>3. Ensure that the flowmeter is pointing in the direction of flow and is operating properly.</li> </ol>
The rate is inaccurate or unstable	<ol style="list-style-type: none"> <li>1. You incorrectly entered a number in the console computer.</li> <li>2. The wheel drive setting is not set to SP3.</li> <li>3. The Speed Cal number is incorrect.</li> <li>4. The Rate 1 or Rate 2 display is not constant when the speed is constant.</li> <li>5. The pressure cannot be adjusted in manual mode with the agitation on and the booms off in the high end of the pressure range.</li> <li>6. The Valve Cal number is not properly set.</li> <li>7. There is a problem with the processor board assembly.</li> </ol>	<ol style="list-style-type: none"> <li>1. Verify that all the numbers entered in the console computer are correct.</li> <li>2. Set the wheel drive setting to SP3.</li> <li>3. Enter the correct Speed Cal number.</li> <li>4. Ensure that the flowmeter is pointing in the direction of flow and the nozzles are appropriate for the rate setting.</li> <li>5. Verify that there is voltage at the valve connector by placing the Master switch to Man with the booms in the Off position and the power switch to the On position. Manually operate the Incr/Decr switch to verify the voltage.</li> <li>6. Enter proper the Valve Cal number.</li> <li>7. Have an Authorized Distributor replace the processor board assembly.</li> </ol>
You cannot vary the rate in manual or automatic mode	<ol style="list-style-type: none"> <li>1. There are breaks in the cable leading to the hydraulic control valve.</li> <li>2. The connections in the cable line are dirty.</li> <li>3. There is no voltage at the valve connector.</li> </ol>	<ol style="list-style-type: none"> <li>1. Replace the cable.</li> <li>2. Clean or replace the cable line.</li> <li>3. Verify that there is voltage at the valve connector by placing the Master switch to the Man position with the booms in the Off position and the power switch to the On position. Manually operate the Incr/Decr switch to verify the voltage.</li> </ol>

Problem	Possible Causes	Corrective Action
	4. The Rate Inc/Dec switch is faulty.	4. Replace the Rate Inc/Dec switch.
The sprayer pressure is correct but the rate is low	1. The nozzle check valves are plugged. 2. The bypass valves are open. 3. The nozzles are not the proper type or of the proper orifice size.	1. Clean or replace the nozzle check valves. 2. Close the bypass valves. 3. Replace the improper nozzles with proper ones.
The total volume does not register	1. There are breaks or shorts in the flowmeter cable. 2. The inside of the flowmeter is dirty or not properly adjusted. 3. The flowmeter transducer is not operating properly.	1. Test the flowmeter cable and repair or replace it if necessary. Refer to Testing the Flowmeter Cable on page 15. 2. Clean and make any necessary adjustments inside the flowmeter. 3. Replace the flowmeter transducer.
The total volume registers flow inaccurately	1. The flowmeter is not pointing in the direction of the flow. 2. The flowmeter is faulty.	1. Install the flowmeter in the direction of the flow. 2. Test the flowmeter cable and repair or replace it if necessary. Refer to Testing the Flowmeter Cable on page 15.

## Testing the Flowmeter Cable

1. Disconnect the console control cable from the flowmeter cable.
2. Hold the cable so that the keyway is in the 12 o'clock position (Fig. 7).

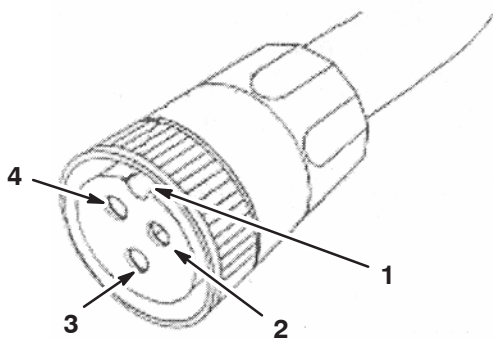

**Figure 7**

- |                                |                                |
|--------------------------------|--------------------------------|
| 1. Keyway                      | 3. Signal (6 o'clock position) |
| 2. Ground (2 o'clock position) | 4. Power (10 o'clock position) |

4. Press the [Total Volume] key.
5. Turn the Pump, Foot, and Boom switches to the On position.
6. Use a small jumper wire or a paper clip to create a short between the 2 o'clock and 6 o'clock sockets.  
**Note:** Each time you make contact, the Total Volume should increase by 1 or more counts.
7. If the Total Volume number does not increase, replace the defective cable.
8. Perform the voltage checks: 2 o'clock to 6 o'clock (+5 VDC); and 2 o'clock to 10 o'clock (+5 VDC).
9. If all the cables are good, replace the flow sensor.

**Note:** After testing the flowmeter cables, enter the correct Meter Cal number before spraying.

3. Enter a Meter Cal number. Refer to Entering the Meter Cal Number on page 8.

