



## 21in Heavy-Duty Recycler<sup>®</sup> Rear Bagger Lawnmower

Model No. 22168 - 250000001 and up.

### Parts Catalog

---

#### Ordering Replacement Parts

To order replacement parts, please supply the part number, the quantity, and the description of each part desired.

#### Understanding Reference Numbers

Each Identified part in an illustration has a reference number. The reference number for a part also appears in the parts list, along with other information about the part.

This catalog uses two special reference number formats, one to indicate parts in a service assembly and another to indicate the quantity of a given part in an illustration.

#### Service Assembly Reference Numbers

Parts in service assemblies have reference numbers in the form a:b. The a represents the reference number of the entire service assembly and the b represents a sequential number unique to each part within the service assembly.

For example, a wheel assembly might be identified by reference number 6, the tire by 6:1, the valve by 6:2, and the wheel by 6:3. When you order the assembly identified by reference number 6, you receive all parts identified by reference numbers 6:1, 6:2, and 6:3. However, you may also order any part individually. Reference numbers of this type appear in illustrations and in part lists.

#### Reference Numbers Indicating Quantity

In an illustration, if a reference number indicates more than one part, the reference number has the form nX y. The n represents the quantity of the part, the X is the multiplication symbol, and the y represents the reference number.

For example, in an illustration, the reference number 2X 37 means that two of the parts identified by reference number 37 are indicated.

# Contents

Description	Page	Description	Page
Deck, Chute and Wheel Assembly	..... 3	Cylinder Barrel Assembly Honda GXV160A1 T1AH	..... 16
Housing Assembly No. 98-7146	..... 5	Crankshaft and Piston Assembly Honda GXV160A1 T1AH	..... 17
Front Wheel and Tire Assembly	..... 6	Camshaft Assembly Honda GXV160A1 T1AH	..... 18
Gear Case Assembly No. 74-1861	..... 7	Recoil Starter Assembly Honda GXV160A1 T1AH	..... 19
Engine, Belt and Blade Assembly	..... 8	Fan Cover Assembly Honda GXV160A1 T1AH	..... 20
Lower Handle Assembly	..... 10	Carburetor Assembly Honda GXV160A1 T1AH	..... 21
Control Panel Assembly	..... 11	Air Cleaner Assembly Honda GXV160A1 T1AH	..... 22
Gearcase and Rear Wheel Assembly	..... 12	Muffler Assembly Honda GXV160A1 T1AH	..... 23
Rear Wheel Assembly	..... 13	Flywheel Assembly Honda GXV160A1 T1AH	..... 24
Grass Bag Assembly No. 106-0975	..... 14	Control Assembly Honda GXV160A1 T1AH	..... 25
Cylinder Head Assembly Honda GXV160A1 T1AH	..... 15	Label Assembly Honda GXV160A1 T1AH	..... 26

## Part Description Abbreviations

Part descriptions in this catalog may include the following abbreviations.

AR. .... as required	HYD. .... hydraulic
ASM. .... assembly	INC. .... incorporated
CARR. .... carriage	LH. .... left hand
DEG. .... degrees	NI. .... nylon insert
EXT. .... external	NPTF. .... national pipe thread fine
FH. .... flat head	PPH. .... phillips pan head
GA. .... gauge	PPHTF. .... phillips pan head thread forming
HF. .... hex flange	PRH. .... phillips round head
HH. .... hex head	PTH. .... phillips truss head
HHF. .... hex head flange	PTO. .... power take off
HHFTF. .... hex head flange thread forming	RH. .... right hand
HJ. .... hex jam	ROPS. .... roll over protection system
HLH. .... hex lag head	SFH. .... slotted fillister head
HOC. .... height-of-cut	SHH. .... slotted hex head
HS. .... hex	SHWH. .... slotted hex washer head
HSBH. .... hex socket button head	SPH. .... slotted pan head
HSFH. .... hex socket flat head	SQH. .... square head
HSH. .... hex socket head	SRH. .... slotted round head
HWH. .... hex washer head	STD. .... standard
HWHTF. .... hex washer head thread forming	TAP. .... self tapping

## Footnotes

❶ Not serviced separately

❷ Obtain parts from your local Honda dealer

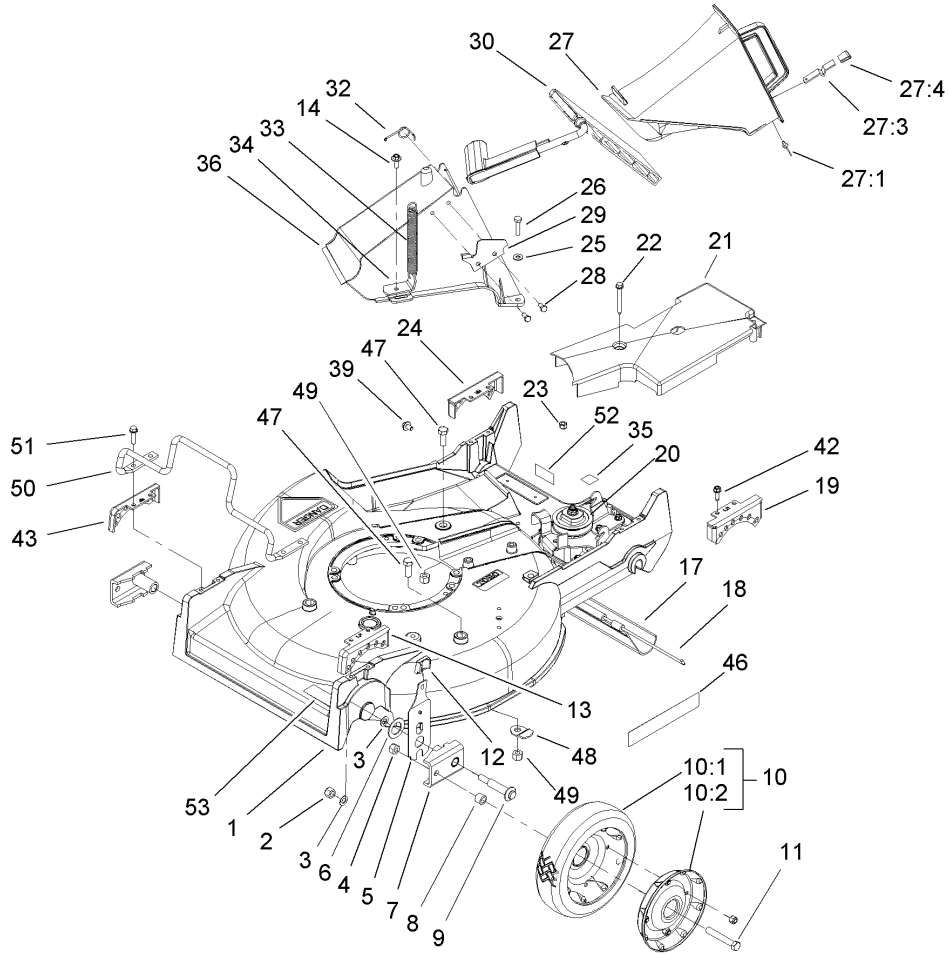

## Deck, Chute and Wheel Assembly

Ref	Part No.	Qty.	Description
1	98-7146	1	Housing
2	3296-6	2	Nut-Lock
3	40-1940	4	Washer
4	32152-2	2	Nut-Lock, Cone
5	66-7560	2	Front Spring Arm ASM
6	257-3	2	Washer-Thrust
7	61-8300	2	Arm-Pivot, Front
8	52-2480	2	Spacer-Wheel
9	27-6232	2	Bolt-Wheel
10	100-2870	2	Wheel And Tire ASM
10:1	53-7740	1	Tire
10:2		1	Wheel ASM
11	323-12	2	Screw-HH
12	25-7740	2	Knob-Arm
13	49-8760	1	Quadrant-Front, LH
14	46-6811	1	Screw-HWH
17	44-0580	1	Shield-Trailing
18	33-3208	1	Rod-Shield
19	49-8740	1	Quadrant-Rear, LH
20	74-1861	1	Gear Case ASM
21	74-1770	1	Cover-Belt
22	37-7260	2	Screw-HH
23	3296-42	2	Nut-Lock, NI
24	49-8750	1	Quadrant-Rear, RH

Ref	Part No.	Qty.	Description
25	3256-22	2	Washer-Flat
26	321-7	2	Screw-HH
27	77-0500	1	Discharge Plug ASM
27:1	3295-35	1	Rivet-Head, Flat
27:3	76-4640	1	Latch-Plug, Discharge
27:4	76-4650	1	Grip-Latch
28	46-8090	2	Screw-Plastite
29	93-3154	1	Latch-Plate
30	93-7351	1	Discharge Door ASM
32	80-3770	1	Retainer-Door
33	76-4660	1	Spring-Door
34	71-9350	1	Bracket-Spring
35	52-2620	1	Label-Grease
36	82-9152	1	Tunnel-Discharge
39	46-6810	1	Screw And Washer ASM
42	49-2040	4	Screw-Tapping
43	49-8770	1	Quadrant-Front, RH
46	106-0689	1	Decal
47	323-6	3	Screw-HH
48	84-8930	2	Shield-Retainer
49	3296-39	3	Nut-Lock, NI
50	99-6722	1	Guard-Engine
51	32144-86	4	Screw-HWHTF
52	92-1779	1	Decal-Warning



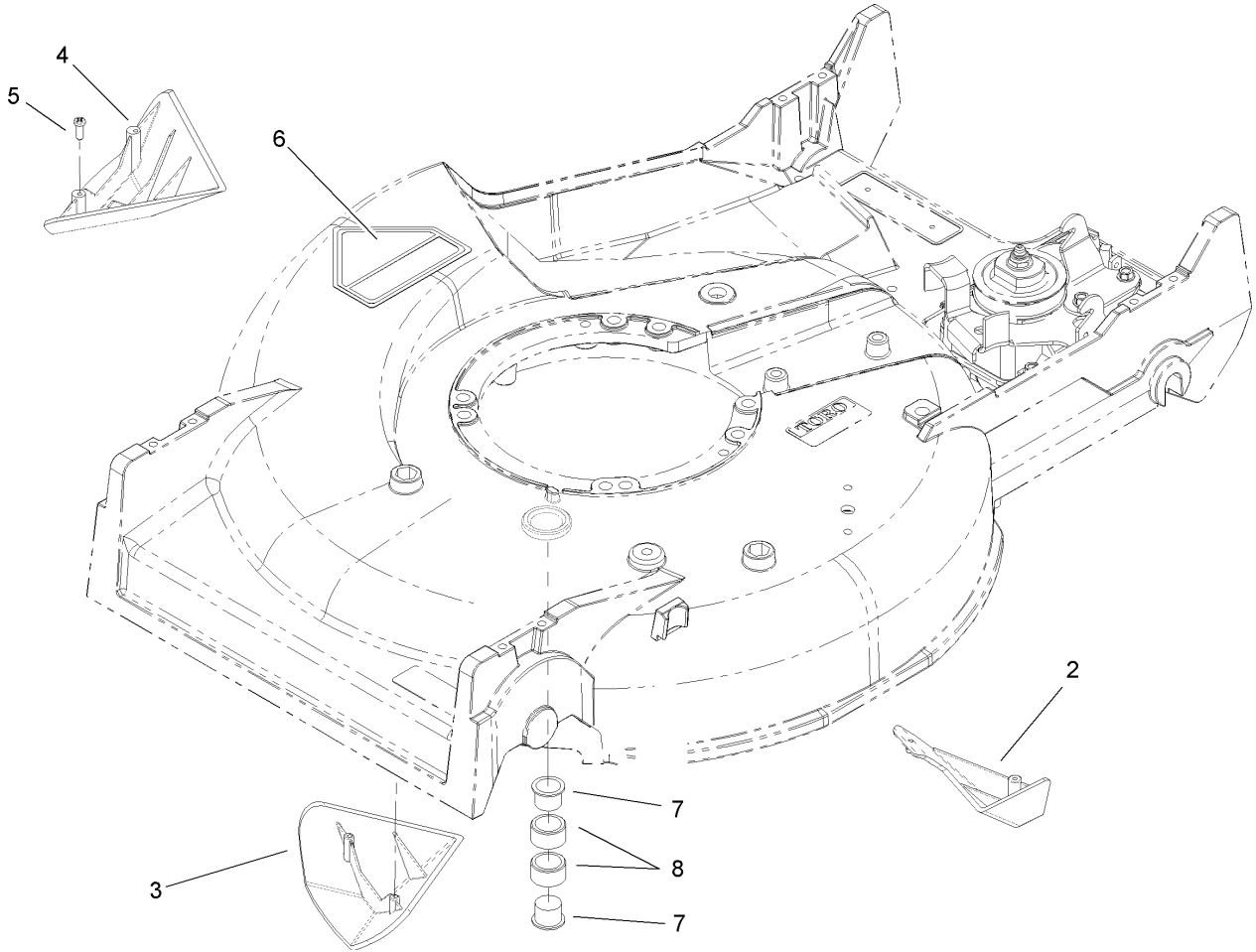

### Housing Assembly No. 98-7146

Ref	Part No.	Qty.	Description				
2	92-1750	1	Kicker-Rear				
3	92-1720	1	Kicker-Front				
4	92-1730	1	Kicker-RH				
5	32144-111	6	Screw-PPH				
6	43-8480	1	Decal-Danger				
7	2410-72	2	Caplug				
8	68-9780	2	Bearing				

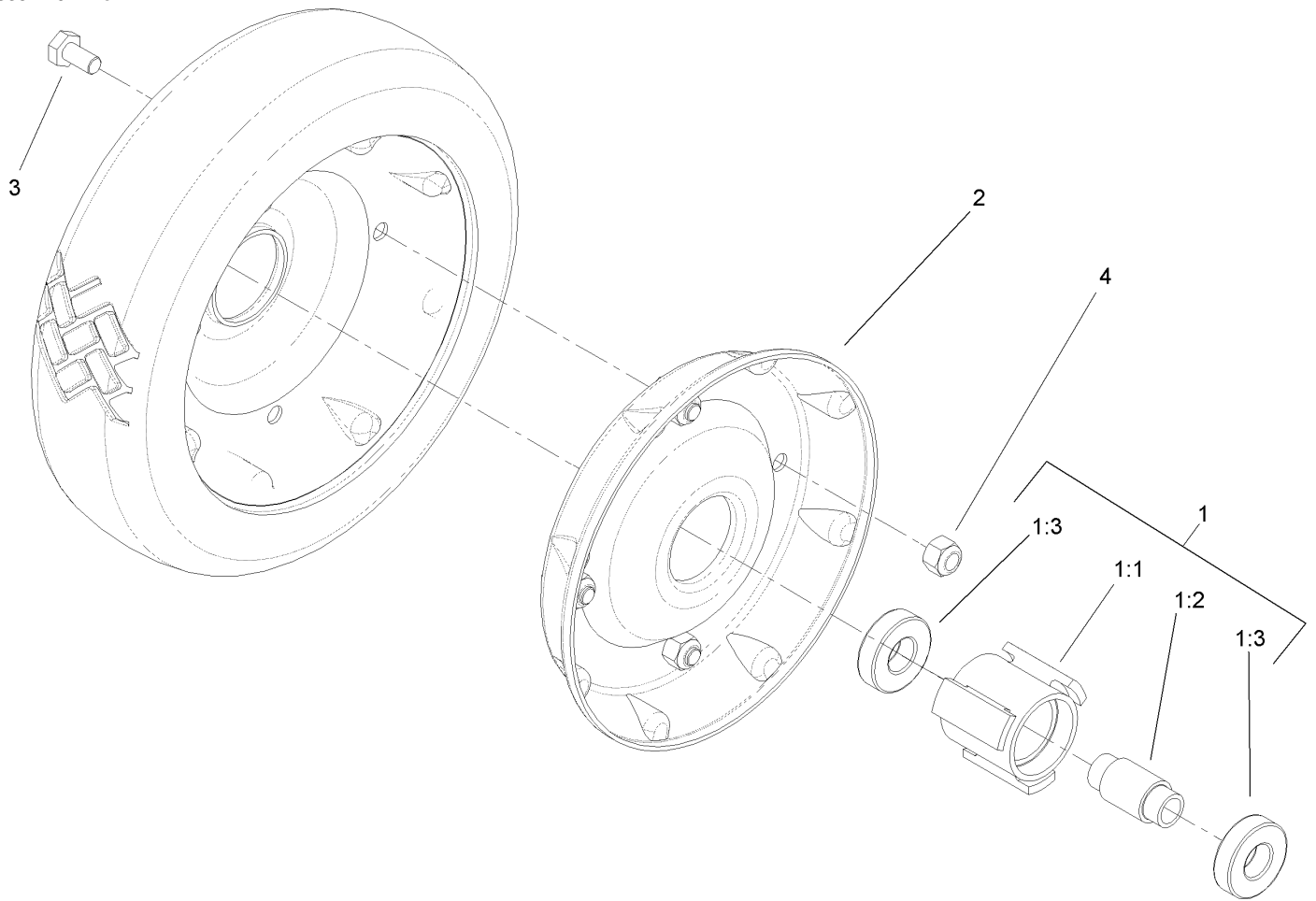

## Front Wheel and Tire Assembly

Ref	Part No.	Qty.	Description
1		1	Hub And Bearing ASM
1:1	52-2410	1	Hub-Bearing
1:2	52-2440	1	Spacer-Bearing
1:3	52-2450	2	Bearing-Wheel
2	53-7780-06	2	Plate-Wheel, Half
3	321-2	4	Screw-HH
4	3296-42	4	Nut-Lock, NI

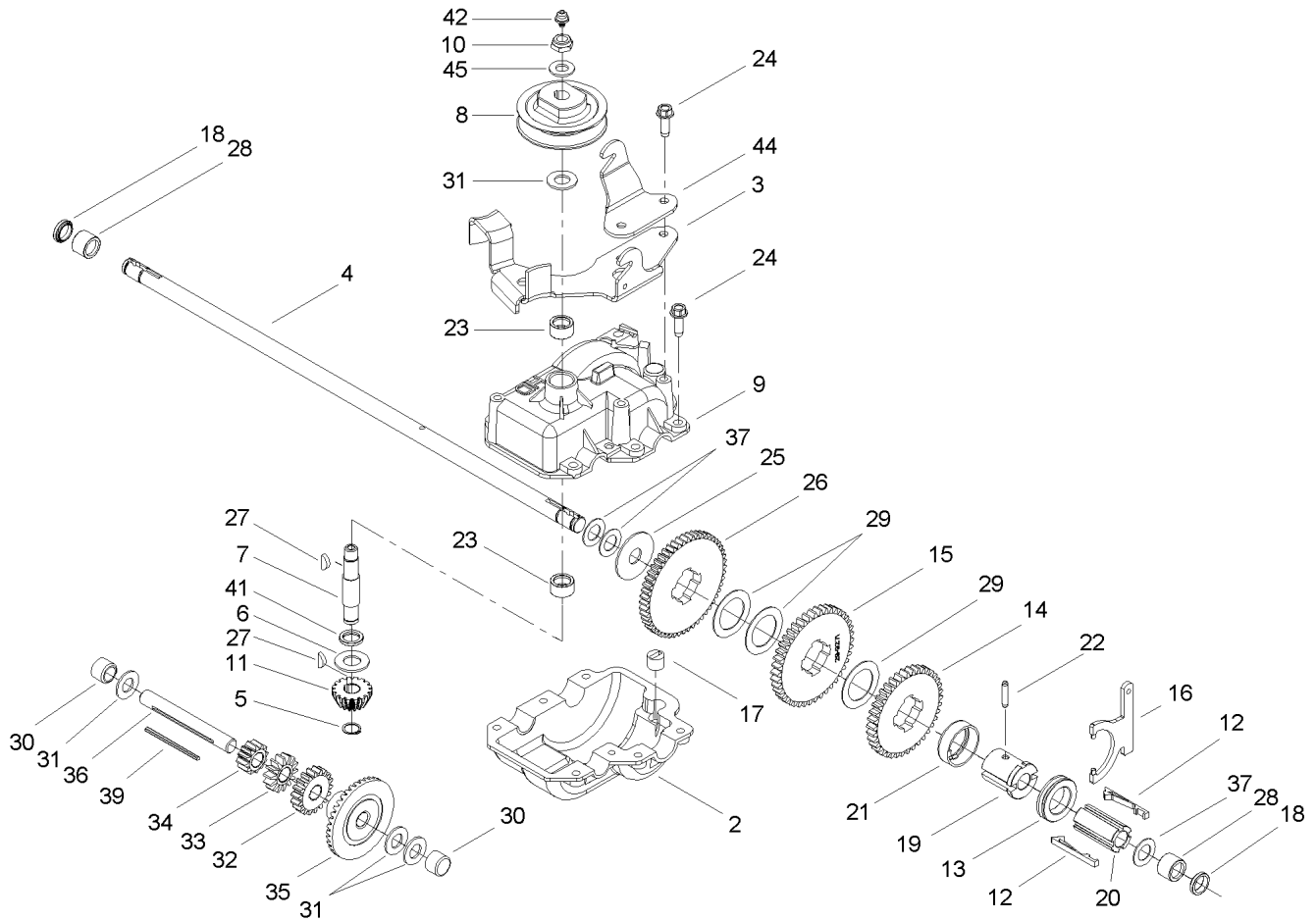
## Gear Case Assembly No. 74-1861

Ref	Part No.	Qty.	Description
2	74-1920	1	Case-Gear, Lower
3	49-8461-03	1	Bracket-Guide, Belt
4	74-1890	1	Shaft-Output
5	32151-57	1	Ring-Retaining
6	47-2910	1	Washer-Thrust
7	68-8190	1	Shaft-Input
8	39-6740	1	Pulley
9	74-1880	1	Case-Gear, Upper
10	3296-5	1	Nut-Lock
11	39-6660	1	Pinion-Bevel
12	29-9330	2	Key-Shift
13	29-9340	1	Collar-Shift
14	42-4740	1	Gear-38 Tooth
15	29-9271	1	Gear-42 Tooth
16	60-8870	1	Yoke-Shift
17	29-9570	1	Bushing-Yoke
18	47-6730	2	Seal-Oil
19	55-8010	1	Sleeve-Gear
20	39-6720	1	Sleeve
21	55-8020	1	Retainer-Key
22	3285-19	1	Pin-Groove
23	47-7270	2	Bearing
24	49-2040	6	Screw-Tapping
25	29-9690	1	Washer

Ref	Part No.	Qty.	Description
26	46-3560	1	Gear
27	3257-1	2	Key-Woodruff
28	48-2060	2	Bearing-Roller
29	36-4770	3	Washer
30	252-103	2	Bearing-Closed
31	36-4792	4	Washer-Thrust
32	39-6650	1	Gear-18T
33	46-3550	1	Gear-14T
34	46-3540	1	Gear-12T
35	74-1760	1	Gear-Bevel
36	53-7950	1	Shaft-Intermediate
37	36-4780	3	Washer
39	39-7842	1	Key
41	47-7260	1	Seal
42	302-63	1	Zerk
44	74-1750-03	1	Bracket-Engage, Traction
45	3256-45	1	Washer-Flat

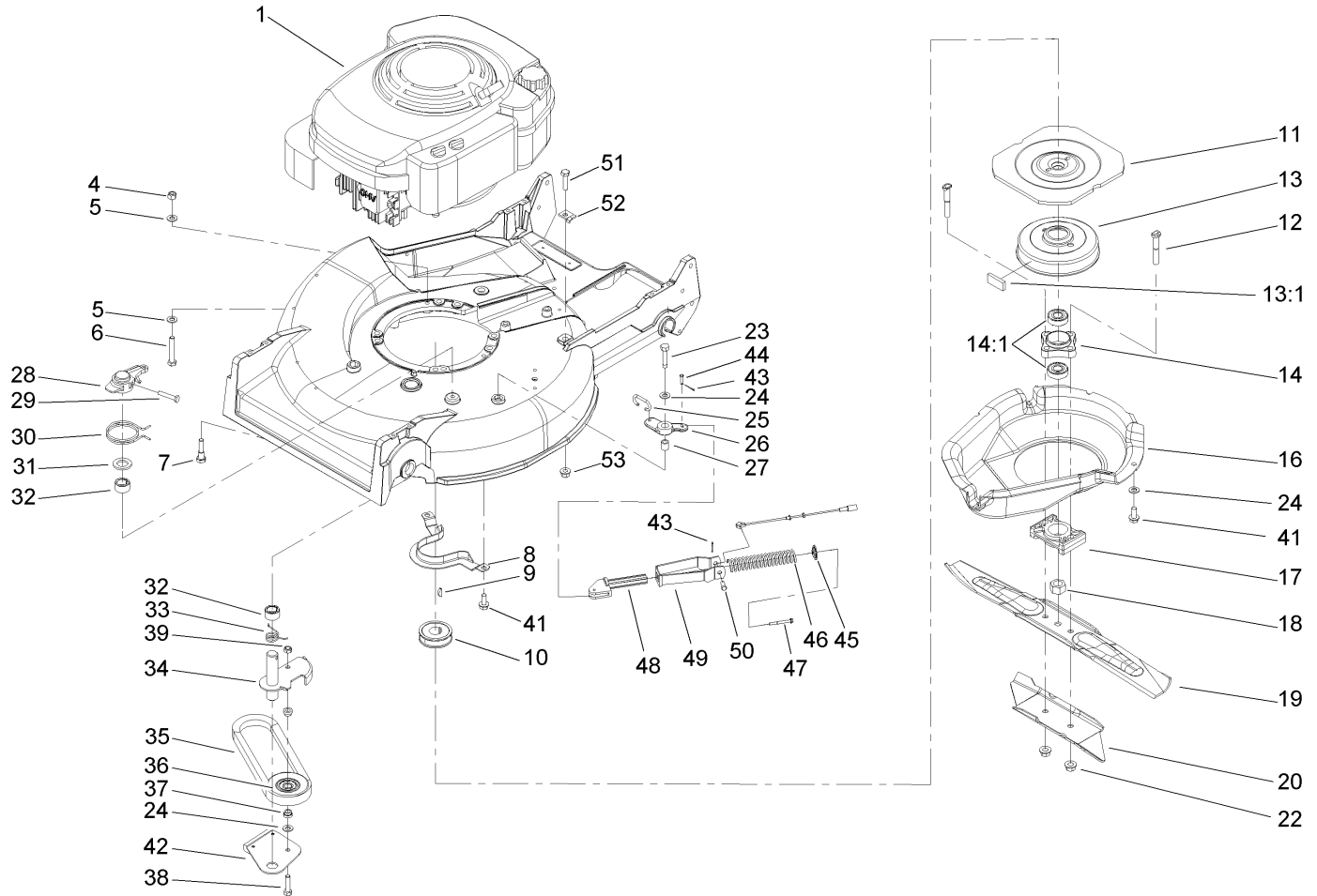

## Engine, Belt and Blade Assembly

Ref	Part No.	Qty.	Description
1		1	Engine-Honda, Gxv160A1-T1Ah
4	3296-29	1	Nut-Lock, NI
5	3256-23	2	Washer-Flat
6	322-10	1	Screw-HH
7	103-2678	3	Screw-Shoulder
8	66-0570-03	1	Bracket-Guide, Belt
9	3257-17	1	Key-Woodruff
10	56-6180	1	Pulley-Driver
11	56-6160-03	1	Flywheel-Bbc
12	42-3190	2	Bolt-Blade
13	94-9431	1	Brake Drum ASM
13:1	52-3480	2	Dampner-Vibration
14	42-6890	1	Hub ASM
14:1	100-1048	2	Bearing-Ball
16	46-5693	1	Shield
17	62-4280	1	Spacer-Blade
18	603164	1	Nut-Blade
19	14-9419	1	Blade
20	91-2255-03	1	Stiffener-Blade
22	54-9190	2	Nut-Lock
23	32104-107	1	Screw-HH
24	3256-23	3	Washer-Flat
25	49-2810	1	Link-Control
26	49-7960	1	Bellcrank

Ref	Part No.	Qty.	Description
27	49-7950	1	Sleeve-Bellcrank
28	49-2820	1	Lever
29	32104-96	1	Screw-HH
30	49-7970	1	Spring-Torsion
31	70-1160	1	Washer
32	68-9780	2	Bearing
33	85-6880	1	Spring-Torsion
34	84-9130	1	Arm-Idler
35	42-0884	1	V-Belt
36	46-5650	1	Pulley-Idler
37	46-5631	2	Hub-Pulley, Idler
38	322-6	1	Screw-HH
39	3296-47	1	Nut-Lock, NI
41	32144-70	3	Screw-HH
42	84-9180	1	Brake Plate ASM
43	3272-1	2	Pin-Cotter
44	84-9050	1	Pin-Spring
45	65-5280	1	Retainer-Spring
46	84-9100	1	Spring
47	46-7040	1	Screw-HWHTF
48	106-0842	1	Guide-Spring
49	107-4087-03	1	Bracket-Spring
50	84-9040	1	Pin-Cable
51	322-6	1	Screw-HH

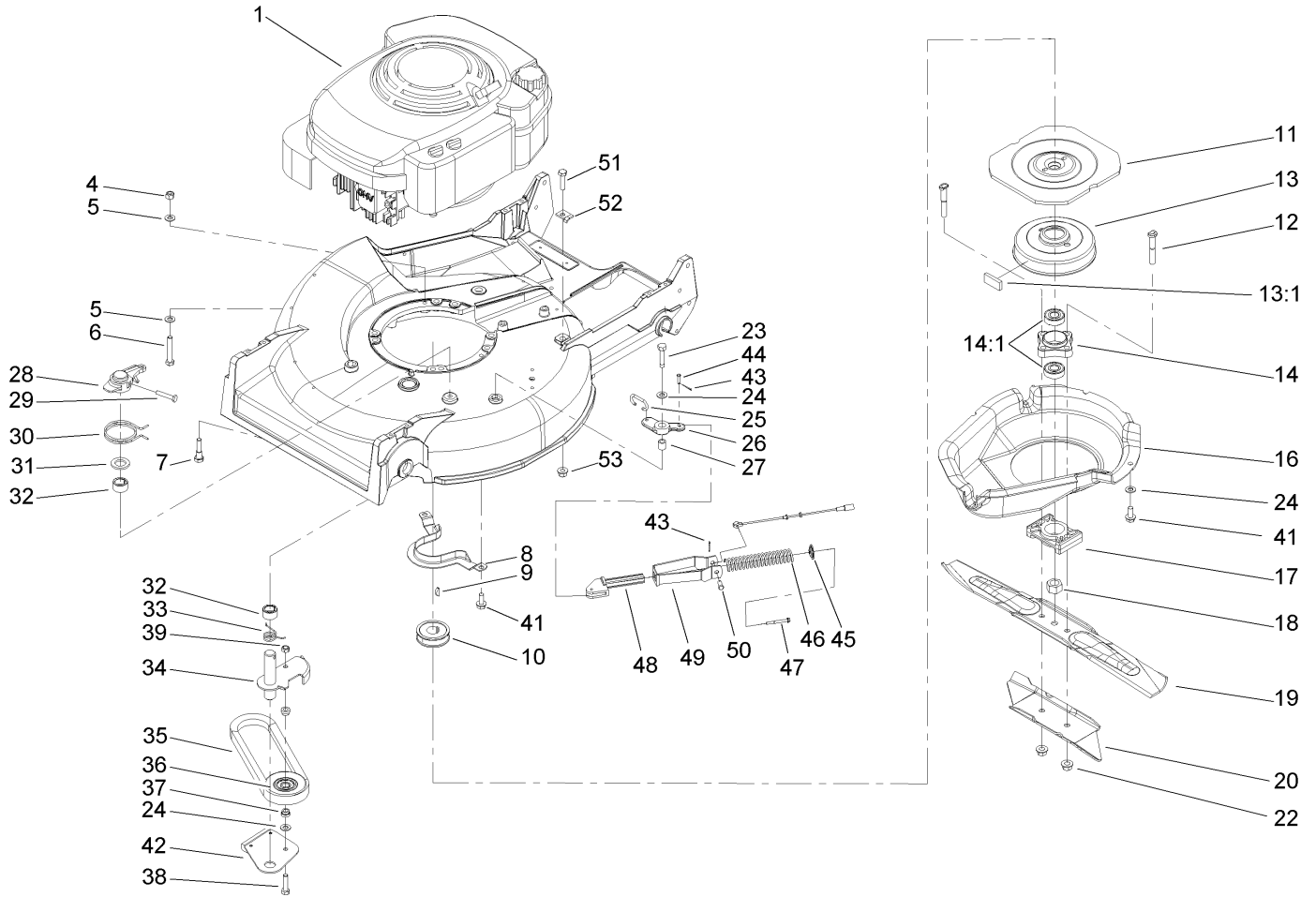

### Engine, Belt and Blade Assembly (continued)

Ref	Part No.	Qty.	Description
52	62-3720	1	Clamp-Cable
53	3296-58	1	Nut-Lock NI

--	--	--	--

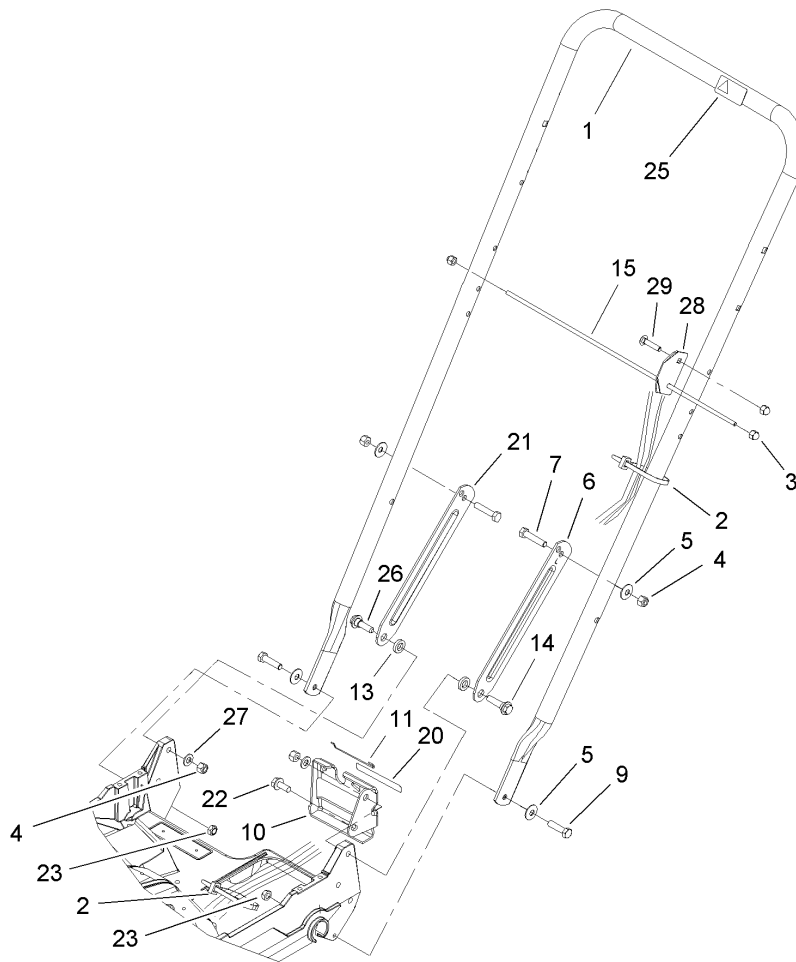

## Lower Handle Assembly

Ref	Part No.	Qty.	Description
1	98-2385-03	1	Handle
2	3290-378	3	Tie-Cable
3	32111-7	3	Nut-Cap
4	3296-29	4	Nut-Lock, NI
5	3290-456	4	Washer-Belleville
6	100-3298-03	1	Latch-Handle, LH
7	322-7	2	Screw-HH
9	322-6	2	Screw-HH
10	74-1741	1	Bracket-Adjustment, Traction
11	46-7030	1	Retainer-Cable
13	3-3287	2	Spacer-Latch, Handle
14	27-7210	1	Screw-Shoulder
15	48-2810	1	Rod-Support, Bag
20	74-1970	1	Decal-Position, Gear
21	100-3297-03	1	Latch-Handle, RH
22	32144-70	1	Screw-HH
23	3296-47	2	Nut-Lock, NI
25	98-4387	1	Decal-Protection, Ear
26	27-7211	1	Screw-Shoulder
27	3256-23	2	Washer-Flat
28	104-1326	1	Plate-Aligning, Bag
29	3229-3	1	Screw-CARR

--	--	--	--

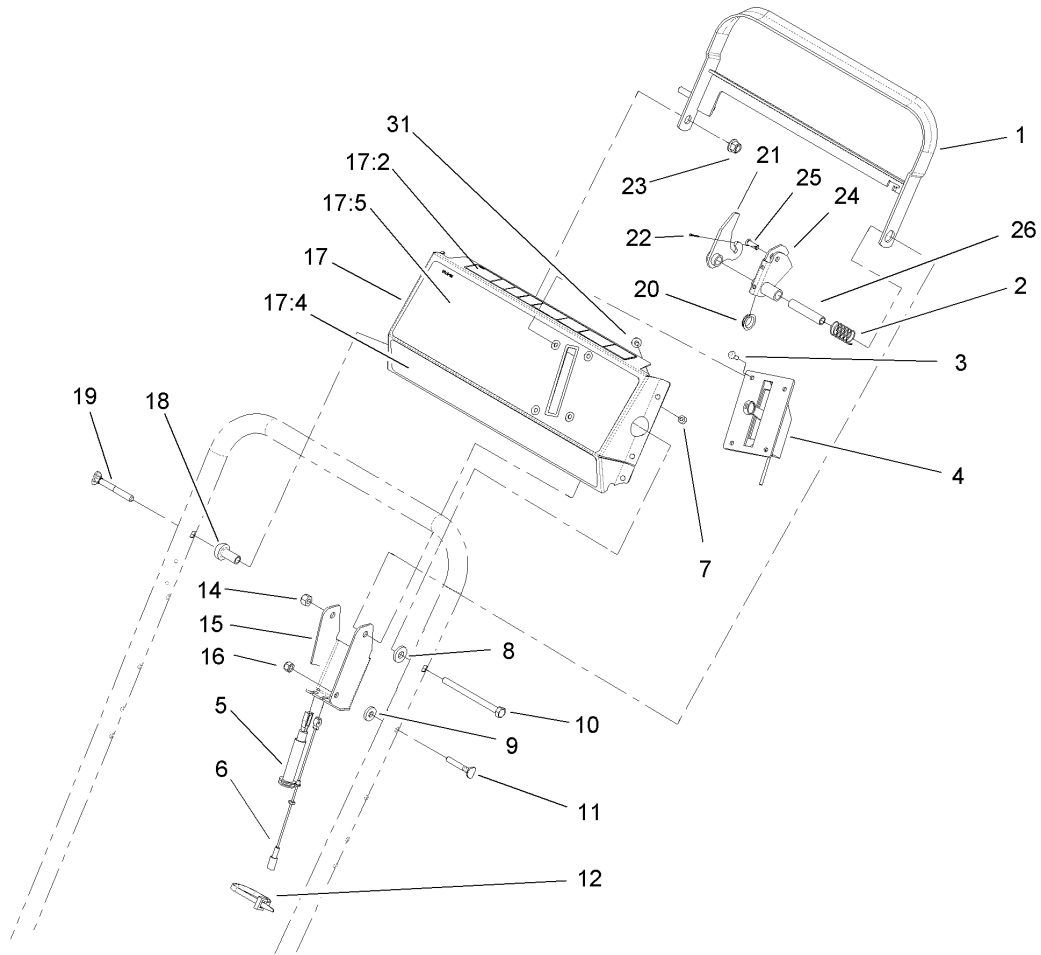

## Control Panel Assembly

Ref	Part No.	Qty.	Description
1	84-8940-03	1	Bar-Control
2	85-6750	1	Spring-Control
3	3250-12	4	Screw-PPH
4	106-0857	1	Control-Throttle
5	84-9120	1	Cable-Traction
6	84-9110	1	Cable-Clutch
7	3296-2	4	Nut-Lock
8	71-9310	1	Spacer
9	71-9320	1	Spacer
10	322-19	1	Screw-HH
11	46-6430	1	Screw-Handle
12	3290-378	1	Tie-Cable
14	3296-29	1	Nut-Lock, NI
15	92-1778-03	1	Bracket-Control
16	3296-42	1	Nut-Lock, NI
17	14-7709	1	Panel ASM
17:2	104-8582	1	Decal-Panel, Danger
17:4	106-0771	1	Decal-Panel
17:5	107-4098	1	Decal-Panel, Proline
18	49-1631	1	Spacer-Support
19	17-9427	1	Screw
20	86-9320	1	Bushing-Flange
21	84-9000	1	Lever-Traction
22	3272-1	1	Pin-Cotter

Ref	Part No.	Qty.	Description
23	3296-58	1	Nut-Lock NI
24	84-8990	1	Lever-Bbc
25	84-9040	1	Pin-Cable
26	84-9030	1	Spacer-Bracket, Control
31	32104-76	6	Screw

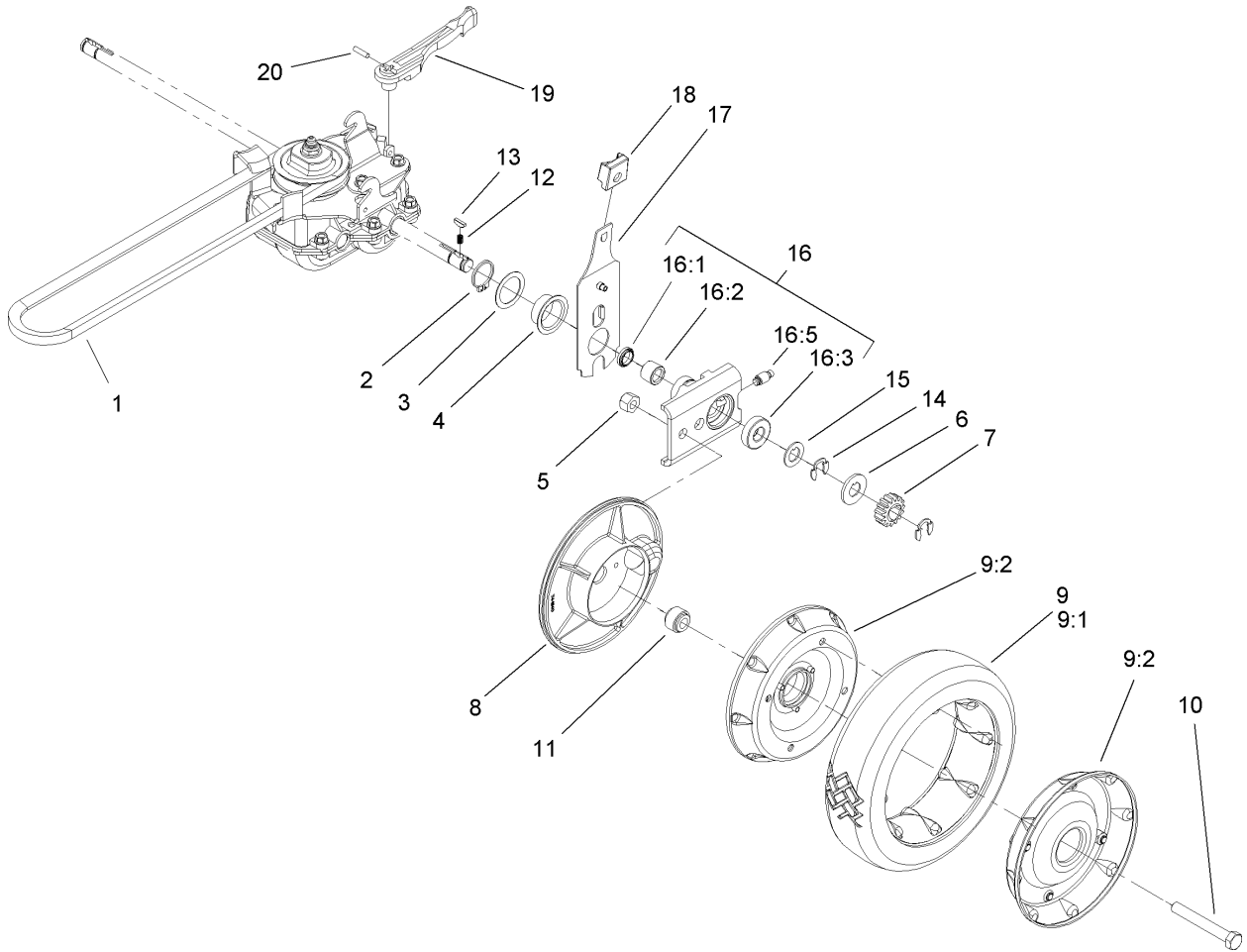

## Gearcase and Rear Wheel Assembly

Ref	Part No.	Qty.	Description
1	36-8070	1	V-Belt
2	32151-36	2	Ring-Retaining
3	74-1810	2	Washer
4	48-2170	2	Cap-End
5	32152-2	2	Nut-Lock, Cone
6	62-3830	2	Washer-Thrust, Outer
7	39-9160	2	Gear-Pinion
8	74-1640	2	Cover-Wheel
9	100-2860	2	Wheel And Tire ASM
9:1	53-7740	1	Tire
9:2		1	Wheel ASM
10	323-13	2	Screw-HH
11	74-1650	2	Spacer-Cover, Wheel
12	39-9650	2	Spring-Compression
13	612066	2	Key
14	32151-68	4	Ring-Retaining
15	49-7700	2	Washer-Thrust, Outer
16	74-1851	2	Pivot Arm ASM
16:1	47-6730	1	Seal-Oil
16:2	48-2060	1	Bearing-Roller
16:3	52-2450	1	Bearing-Wheel
16:5	92-6316	1	Zerk
17	66-7561	2	Rear Spring Arm ASM
18	25-7740	2	Knob-Arm

Ref	Part No.	Qty.	Description
19	74-1960	1	Lever-Shift
20	32121-99	1	Pin-Coil
99	106-0975	1	Grass Bag ASM





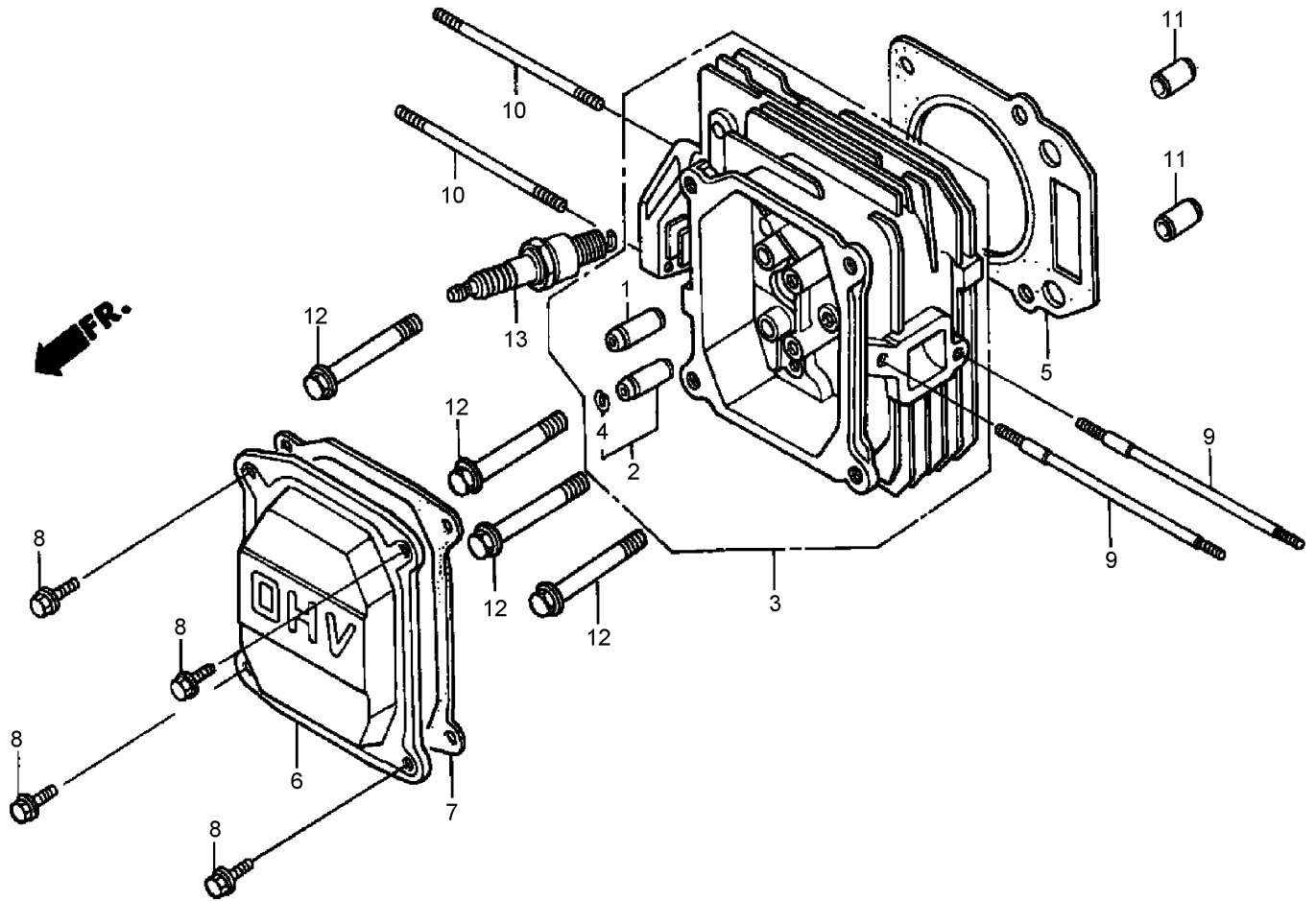

## Cylinder Head Assembly Honda GXV160A1 T1AH

Ref	Part No.	Qty.	Description
1	12204-ZE1-306	1	Guide-Valve (Os)
2	12205-ZE1-315	1	Guide-Valve, Exhaust (Os)
3	12210-Z1V-000	1	Head-Cylinder
4	12216-ZE5-300	1	Clip-Guide, Valve
5	12251-ZE7-000	1	Gasket-Head, Cylinder
6	12311-ZG9-800	1	Cover-Head
7	12391-ZE7-T00	1	Gasket-Cover, Cylinder Head
8	90013-883-000	4	Bolt-Flange (6X12)
9	90043-ZE6-000	2	Bolt-Stud (6X109)
10	90048-ZC3-000	2	Bolt-Stud (6X85)
11	94301-10160	2	Pin-Dowel (10X16)
12	95701-08050-00	4	Bolt-Flange (8X50)
13	98079-54846	1	Plug-Spark (Bpr4Es)
13	98079-54855	1	Plug-Spark (W14Epr-U)
13	98079-55846	1	Plug-Spark (Bpr5Es)

Ref	Part No.	Qty.	Description
13	98079-55855	1	Plug-Spark (W16Epr-U)
13	98079-56846	1	Plug-Spark (Bpr6Es)
13	98079-56855	1	Plug-Spark (W20Epr-U)

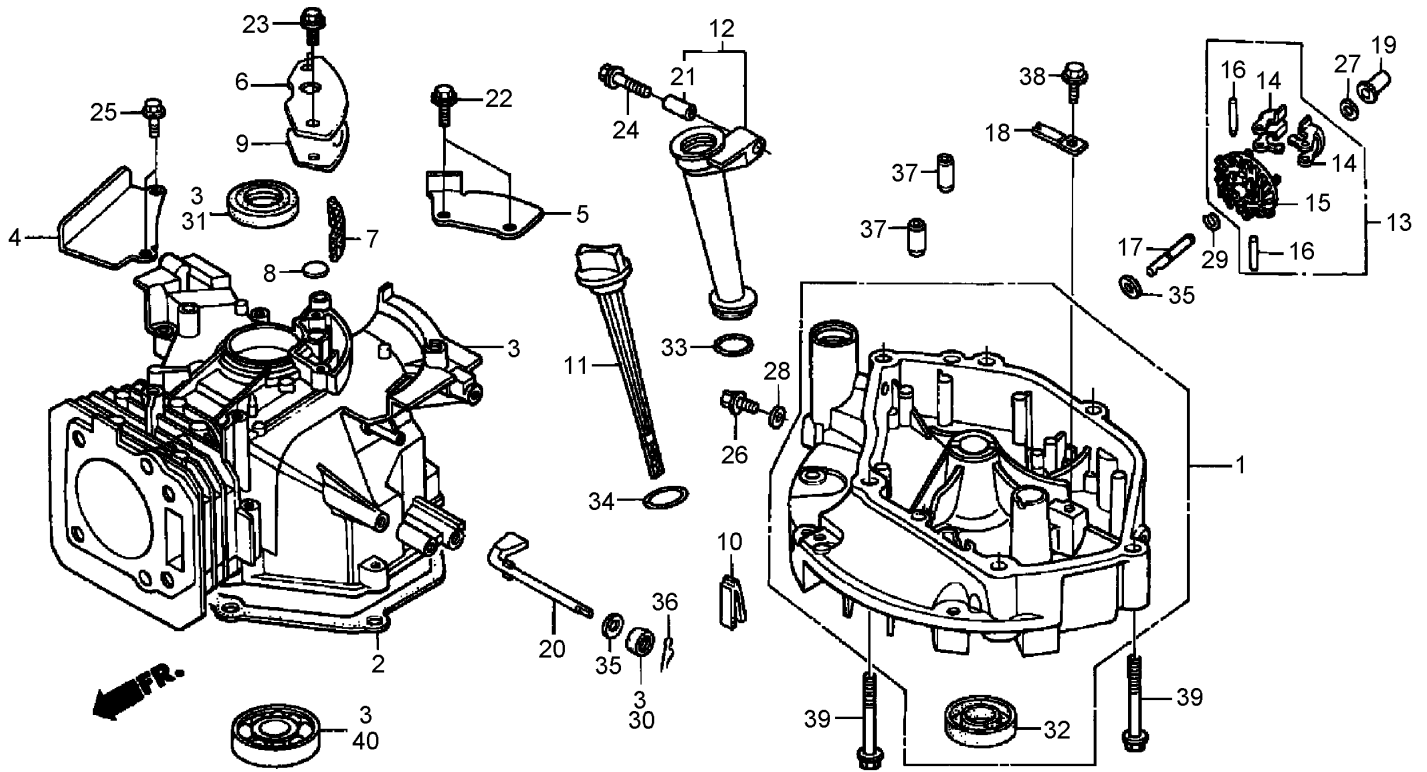

## Cylinder Barrel Assembly Honda GXV160A1 T1AH

Ref	Part No.	Qty.	Description
①	11300-Z1V-000	1	Oil Pan ASM
②	11381-ZE7-M10	1	Gasket-Pan, Oil
③	12000-Z2J-000	1	Cylinder ASM
④	12125-ZE7-000	1	Plate-Guide
⑤	12126-ZE7-W00	1	Plate A-Guide
⑥	12355-Z1V-000	1	Cover-Breather
⑦	12367-883-003	1	Filter-Breather
⑧	12372-ZE7-000	1	Valve-Breather
⑨	12373-ZE7-000	1	Gasket-Cover, Breather
⑩	15335-ZE7-000	1	Rubber-Return, Oil
⑪	15620-ZE6-810	1	Dipstick-Oil
⑫	15630-ZE6-810	1	Extension-Filler, Oil (106Mm)
⑬	16510-ZE6-000	1	Governor ASM

Ref	Part No.	Qty.	Description
⑭	16511-ZE1-000	2	Weight-Governor
⑮	16512-ZE6-000	1	Holder-Weight, Governor
⑯	16513-ZE1-000	2	Pin-Weight, Governor
⑰	16515-ZE6-010	1	Shaft-Holder, Governor
⑱	16525-ZE6-010	1	Plate-Holder, Governor Shaft
⑲	16531-Z1T-000	1	Slider-Governor
⑳	16541-ZE7-000	1	Shaft-Arm, Governor
㉑	17240-ZE6-000	1	Collar-Extension
㉒	90013-883-000	2	Bolt-Flange (6X12)
㉓	90014-952-000	2	Bolt-Flange (6X14)
㉔	90017-883-000	1	Bolt-Flange (6X32)
㉕	90022-888-010	2	Bolt-Flange (6X20)
㉖	90131-ZE1-000	1	Bolt-Plug, Drain

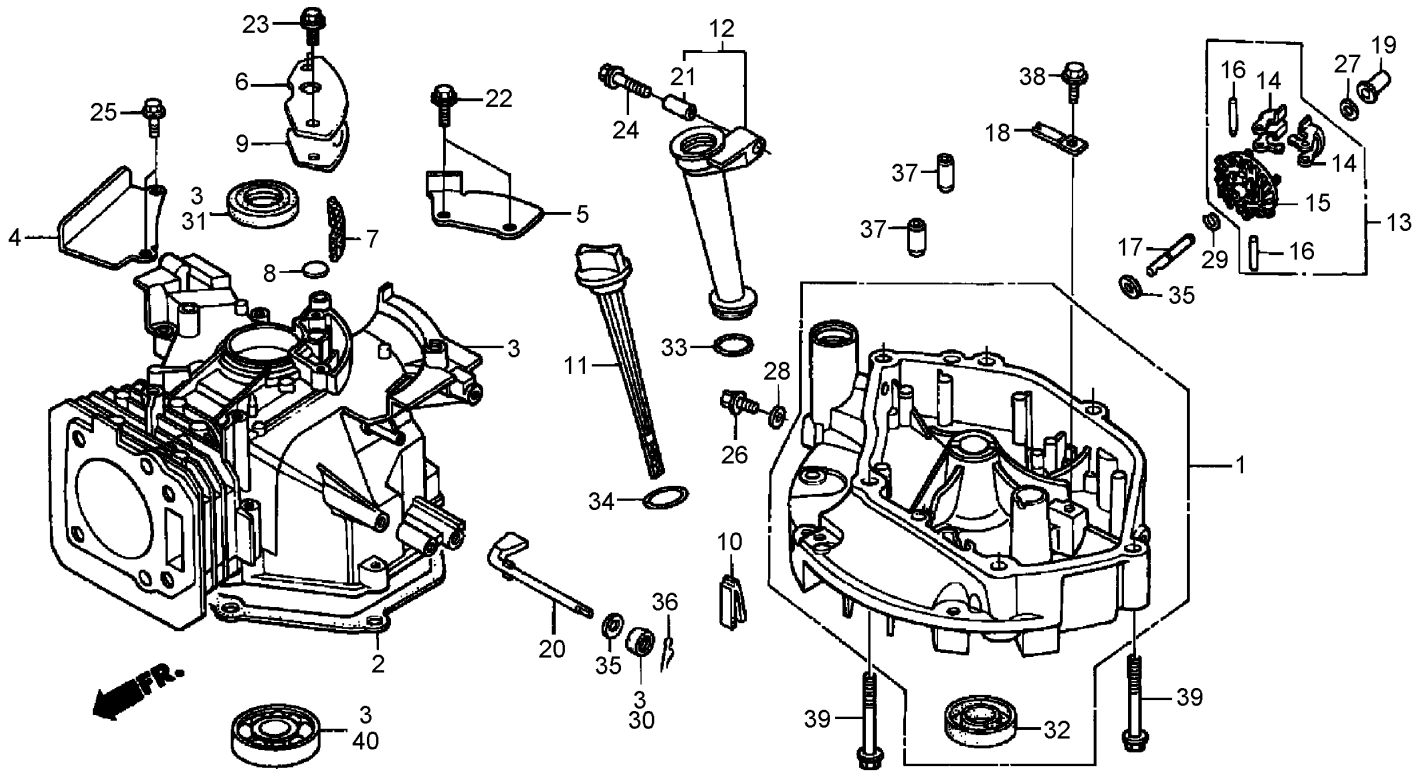

## Cylinder Barrel Assembly Honda GXV160A1 T1AH (continued)

Ref	Part No.	Qty.	Description
27	90451-Z1T-000	1	Washer-Thrust(6Mm)
28	90601-ZE1-000	1	Washer-Plug, Drain (10.2Mm)
29	90602-ZE1-000	1	Clip-Holder, Governor
30	91231-Z1V-003	1	Seal-Oil (6X11X4)
31	91251-Z1V-003	1	Seal-Oil (25X38X7)
32	91252-Z1V-003	1	Seal-Oil (25.4X40X7)
33	91301-ZE9-003	1	O-Ring (22.5X2.2)
34	91301-805-000	1	O-Ring (26X2.7)
35	94101-06800	2	Washer-Plain (6Mm)
36	94251-08000	1	Pin-Lock (8Mm)
37	94301-08140	2	Pin-Dowel (8X14)
38	95701-06012-08	1	Bolt-Flange (6X12)
39	95701-08050-00	6	Bolt-Flange (8X50)
40	96100-62050-00	1	Bearing-Ball, Radial

--	--	--	--

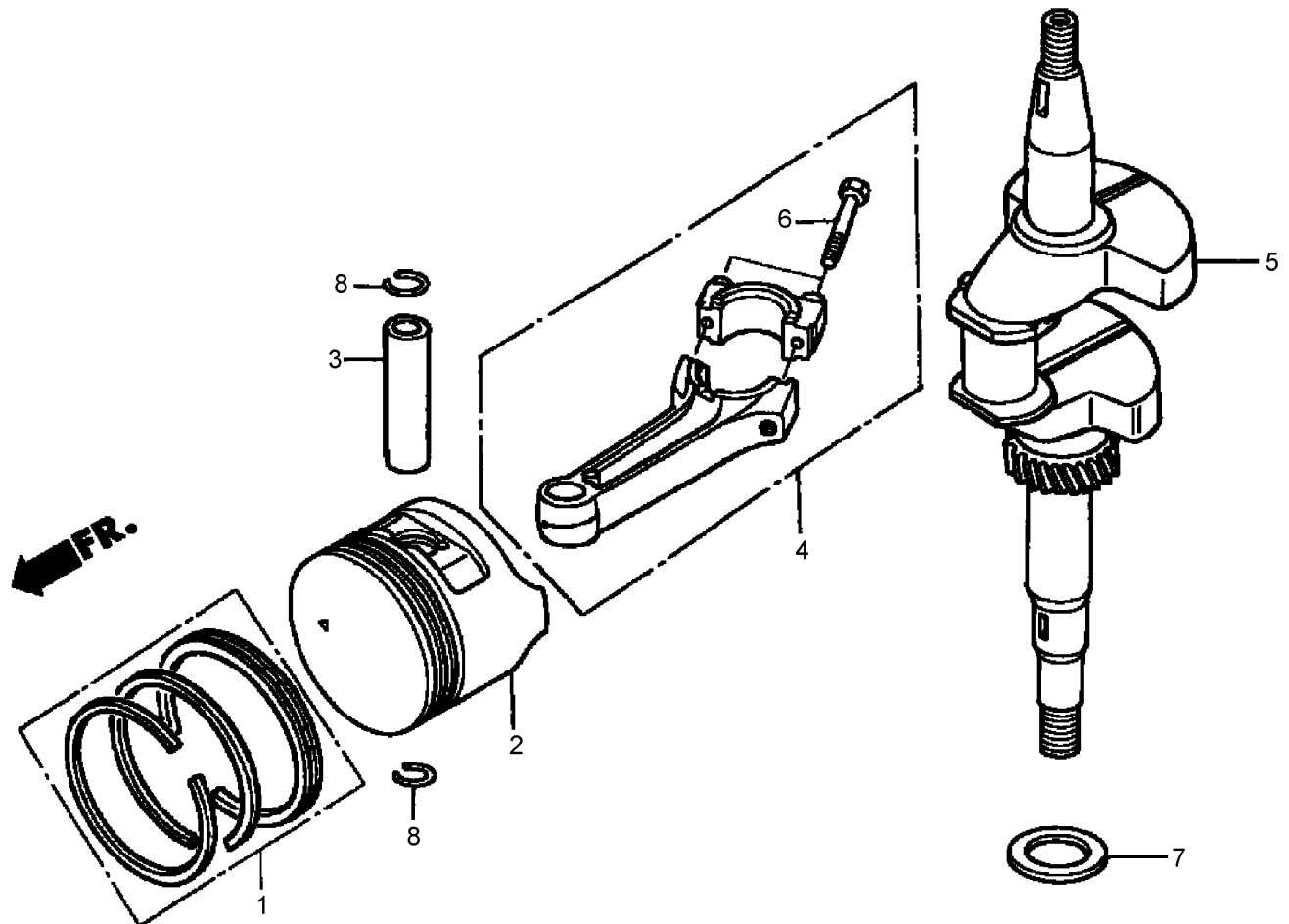

## Crankshaft and Piston Assembly Honda GXV160A1 T1AH

Ref	Part No.	Qty.	Description
①	13010-ZL0-003	1	Ring Set-Piston (STD)
①	13010-ZL0-004	1	Ring Set-Piston (STD) (Nippon)
①	13011-ZL0-003	1	Ring Set-Piston (Os0.25)
①	13011-ZL0-004	1	Ring Set-Piston (Os0.25)(Nippon)
①	13012-ZL0-003	1	Ring Set-Piston (Os0.50)
①	13012-ZL0-004	1	Ring Set-Piston (Os0.50) (Nippon)
①	13013-ZL0-003	1	Ring Set-Piston (0.75)
①	13013-ZL0-004	1	Ring Set-Piston (0.75)(Nippon)
②	13101-ZH8-010	1	Piston (STD)
②	13101-Z1T-000	1	Piston (STD)
②	13102-ZE7-020	1	Piston (Os 0.25)
②	13103-ZE7-020	1	Piston (Os 0.50)
②	13104-ZE7-020	1	Piston (0.75)

Ref	Part No.	Qty.	Description
③	13111-Z1T-000	1	Pin-Piston
④	13200-Z1V-000	1	Connecting Rod ASM
⑤	13310-ZE7-V20	1	Crankshaft
⑥	90001-ZE1-000	2	Bolt-Rod, Connecting
⑦	90401-ZE7-W00	1	Washer-Thrust (25.6Mm)
⑧	90551-ZE1-000	2	Clip-Pin, Piston (18Mm)

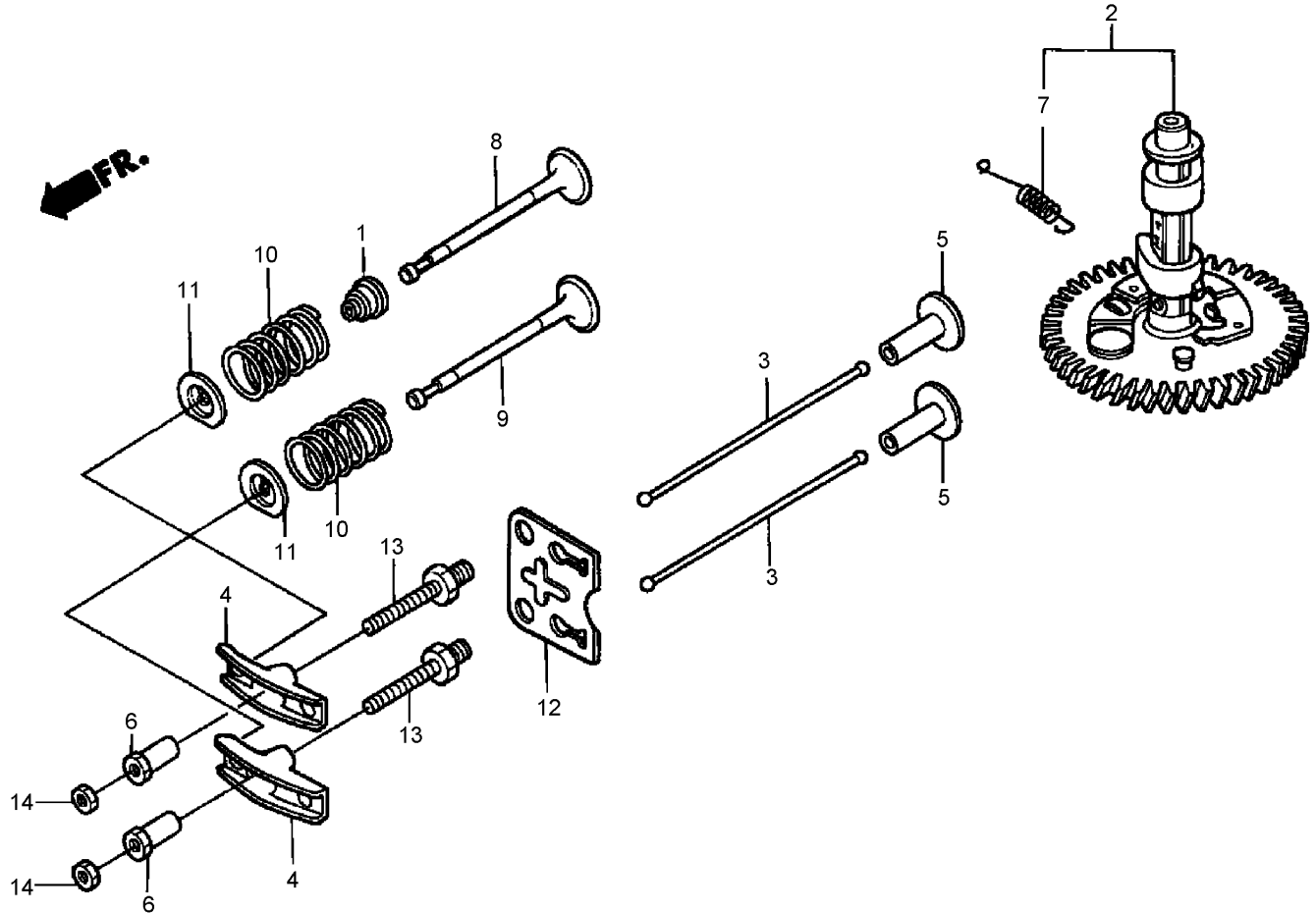

## Camshaft Assembly Honda GXV160A1 T1AH

Ref	Part No.	Qty.	Description
①	12209-ZE6-003	1	Seal-Stem, Valve
②	14100-ZE7-000	1	Camshaft ASM
③	14410-ZE1-010	2	Rod-Push
④	14431-ZE1-000	2	Arm-Rocker, Valve
⑤	14441-ZE1-010	2	Lifter-Valve
⑥	14451-ZE1-013	2	Pivot-Arm, Rocker
⑦	14568-ZE1-000	1	Spring-Return, Weight
⑧	14711-ZF1-000	1	Valve-Intake
⑨	14721-ZE7-000	1	Valve-Exhaust
⑩	14751-ZE1-000	2	Spring-Valve
⑪	14771-ZE1-000	2	Retainer-Valve Spring, Intake
⑫	14791-ZE1-010	1	Plate-Guide, Push Rod
⑬	90012-ZE0-010	2	Bolt-Pivot (8Mm)

Ref	Part No.	Qty.	Description
⑭	90206-ZE1-000	2	Nut-Adj., Pivot

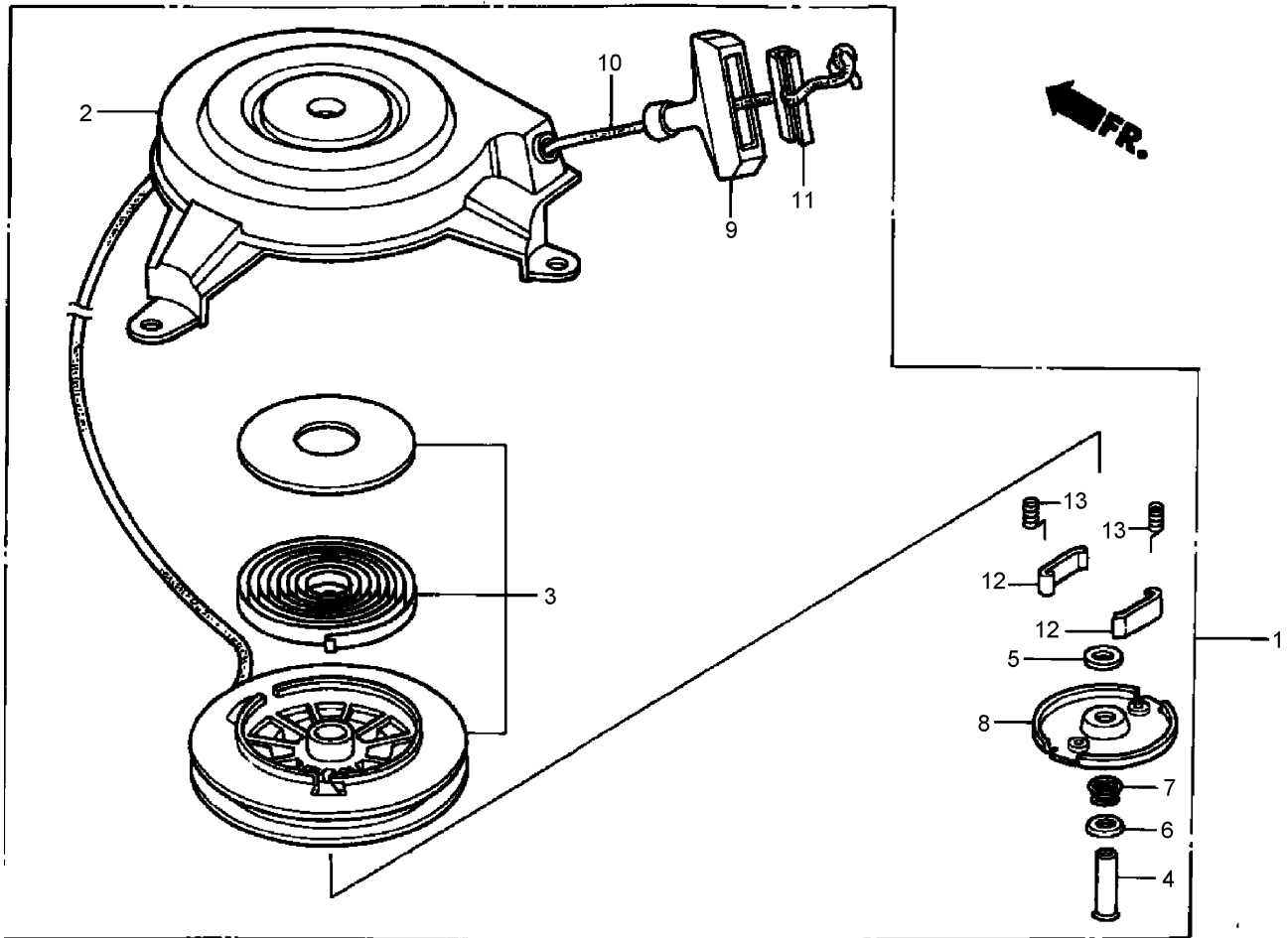

## Recoil Starter Assembly Honda GXV160A1 T1AH

Ref	Part No.	Qty.	Description
①	28400-ZG9-803	1	Recoil Starter ASM
②	28402-ZG9-802	1	Housing ASM
③	28415-ZG9-802	1	Pulley And Spring ASM
④	28419-ZG9-802	1	Pin-Center
⑤	28431-ZG9-802	1	Plate A-Friction
⑥	28432-ZG9-802	1	Plate B-Friction
⑦	28441-ZG9-802	1	Spring-Friction
⑧	28444-ZG9-802	1	Retainer
⑨	28461-ZE6-T02	1	Handle
⑩	28462-ZG9-802	1	Rope-Starter, Recoil
⑪	28463-ZE6-T02	1	Handle-Reinforcement
⑫	28485-ZE6-T02	2	Ratchet-Starter
⑬	28486-ZE6-T02	2	Spring-Dog

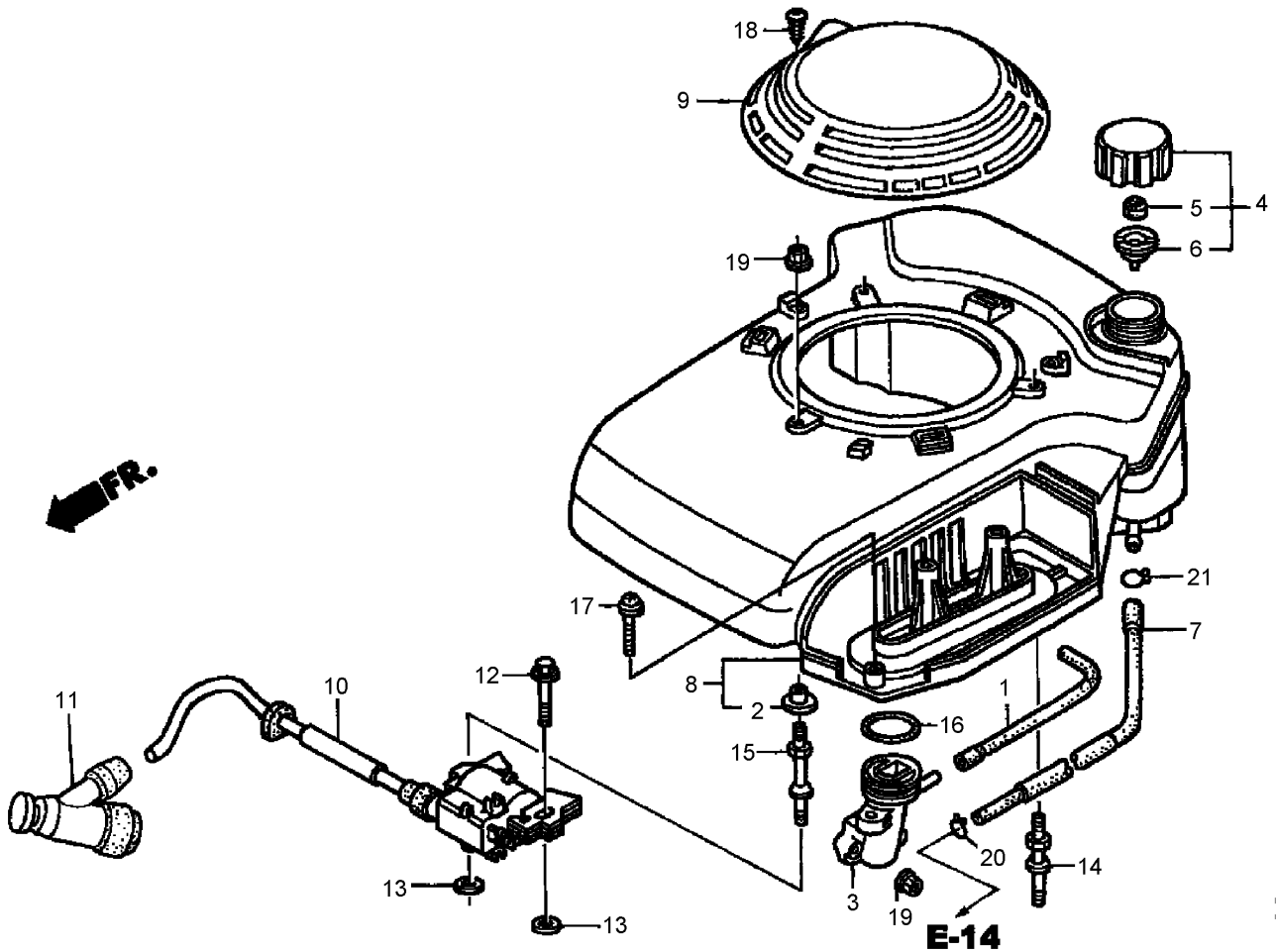
## Fan Cover Assembly Honda GXV160A1 T1AH

Ref	Part No.	Qty.	Description
①	15721-ZE7-000	1	Tube-Breather
②	17216-PE2-003	3	Collar-Cleaner, Air
③	17410-ZE7-W00	1	Elbow-Cleaner, Air
④	17620-ZE7-000	1	Fuel Tank Cap ASM
⑤	17622-888-010	1	Sponge-Breather, Fuel Cap
⑥	17624-ZE7-000	1	Gasket-Cap, Fuel
⑦	17700-ZE7-W00	1	Fuel Tank Tube ASM
⑧	19610-ZE7-W01ZA	1	Cover-Fan
⑨	19615-ZG9-801ZA	1	Hood-Cover, Fan
⑩	30500-ZE7-043	1	Ignition Coil ASM
⑪	30700-ZE6-023	1	Noise Suppressor Cap ASM
⑫	90015-883-000	1	Bolt-Flange (6X28)
⑬	90581-GB5-610	2	Washer-Plain (6Mm)

Ref	Part No.	Qty.	Description
⑭	90041-ZE7-W00	2	Bolt A-Stud
⑮	90042-ZE7-W00	1	Bolt-Stud
⑯	91301-ZG9-800	1	O-Ring (33.3X3.5)
⑰	93891-06035-10	1	Screw-Washer (6X35)
⑱	93913-24580	1	Screw-Tapping (4X20)
⑲	94050-06000	5	Nut-Flange (6Mm)
⑳	95002-02080	1	Clip-Tube (B8)
㉑	95002-50000	1	Clip-Tube (C9)

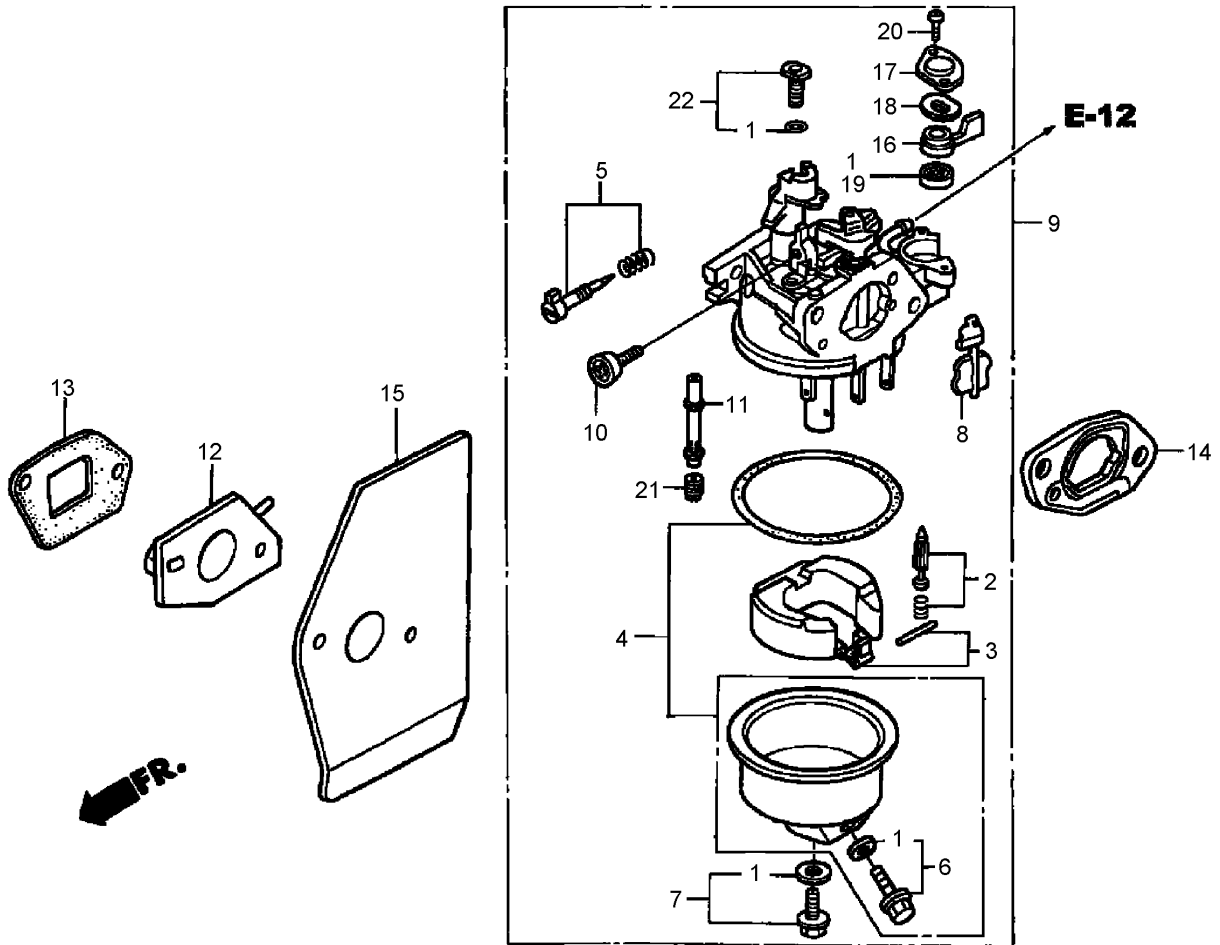

## Carburetor Assembly Honda GXV160A1 T1AH

Ref	Part No.	Qty.	Description
①	10060-ZE0-025	1	Gasket Set
②	16011-ZE0-005	1	Valve Set-Float
③	16013-ZE0-005	1	Float Set
④	16015-ZE0-831	1	Chamber Set-Float
⑤	16016-ZH7-W01	1	Screw Set
⑥	16024-ZE1-811	1	Screw Set-Drain
⑦	16028-ZE0-005	1	Screw-Set
⑧	16045-ZE7-005	1	Choke Set
⑨	16100-ZE7-W21	1	Carburetor ASM
⑩	16124-ZE0-005	1	Screw-Stop, Throttle
⑪	16166-ZE7-W10	1	Nozzle-Main
⑫	16211-ZE7-000	1	Insulator-Carburetor
⑬	16212-ZE7-M10	1	Gasket-Insulator

Ref	Part No.	Qty.	Description
⑭	16220-ZE6-010	1	Spacer-Carburetor
⑮	16221-ZE7-M11	1	Gasket-Carburetor
⑯	16953-ZE1-812	1	Lever-Valve
⑰	16954-ZE1-812	1	Plate-Setting, Lever
⑱	16956-ZE1-811	1	Spring-Lever, Valve
⑲	16957-ZE1-812	1	Gasket-Valve
⑳	93500-03006-0H	2	Screw-Pan (3X6)
㉑	99101-ZH8-0600	1	Jet-Main (No. 60)
㉑	99101-ZH8-0620	1	Jet-Main (No. 62)
㉑	99101-ZH8-0650	1	Jet-Main (No. 65)
㉒	99204-ZE0-0350	1	Jet Set-Pilot (No. 35)



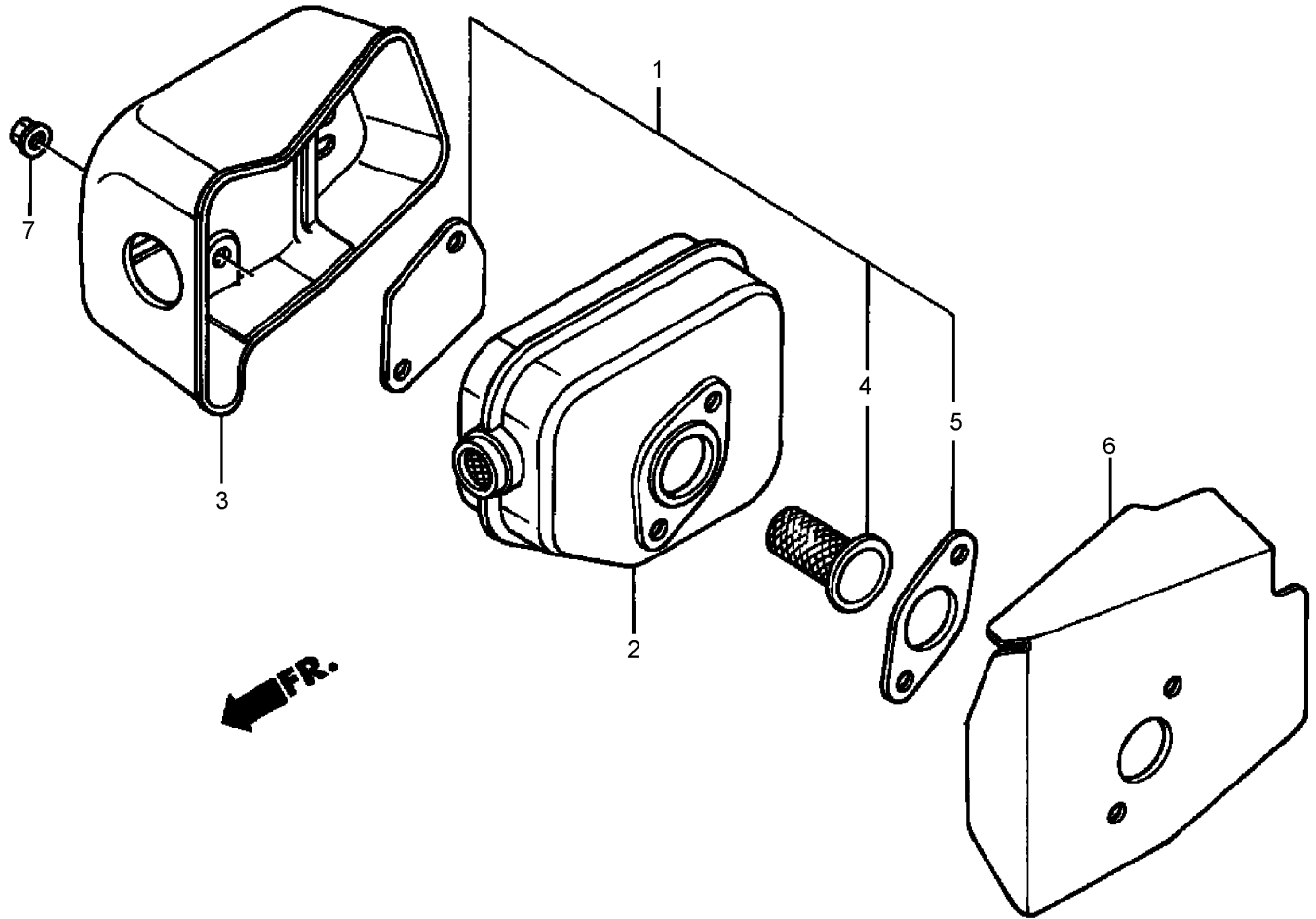

## Muffler Assembly Honda GXV160A1 T1AH

Ref	Part No.	Qty.	Description				
①	06180-ZE6-820	1	Spark Arrester Kit				
②	18310-ZG9-J01	1	Muffler				
③	18320-ZG9-M01	1	Protector-Muffler				
④	06180-888-505	1	Spark Arrester Kit				
④	06180-888-810	1	Spark Arrester Kit				
⑤	18381-ZE6-820	1	Gasket-Muffler				
⑥	18381-ZG9-M00	1	Gasket-Muffler				
⑦	90343-ZE6-000	2	Nut-Self Lock (6Mm)				

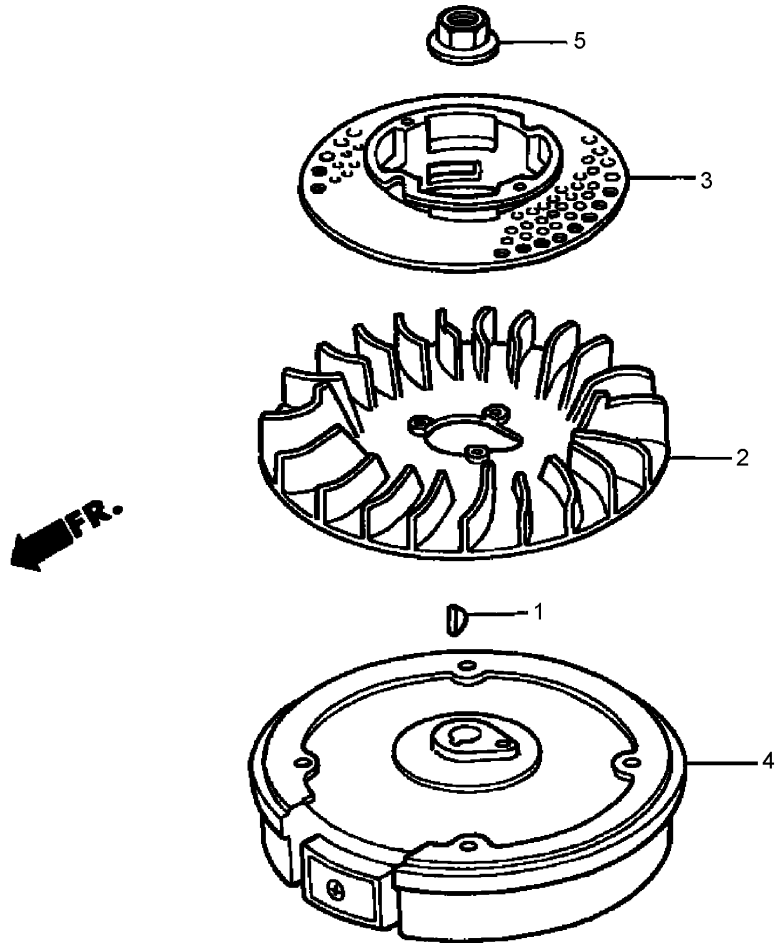

## Flywheel Assembly Honda GXV160A1 T1AH

Ref	Part No.	Qty.	Description				
①	13331-357-000	1	Key-Woodruff (25X18)				
②	19511-ZE1-000	1	Fan-Cooling				
③	28451-ZE7-W00	1	Pulley-Starter				
④	31100-ZE7-010	1	Flywheel (STD)				
⑤	90201-878-003	1	Nut (14Mm)				

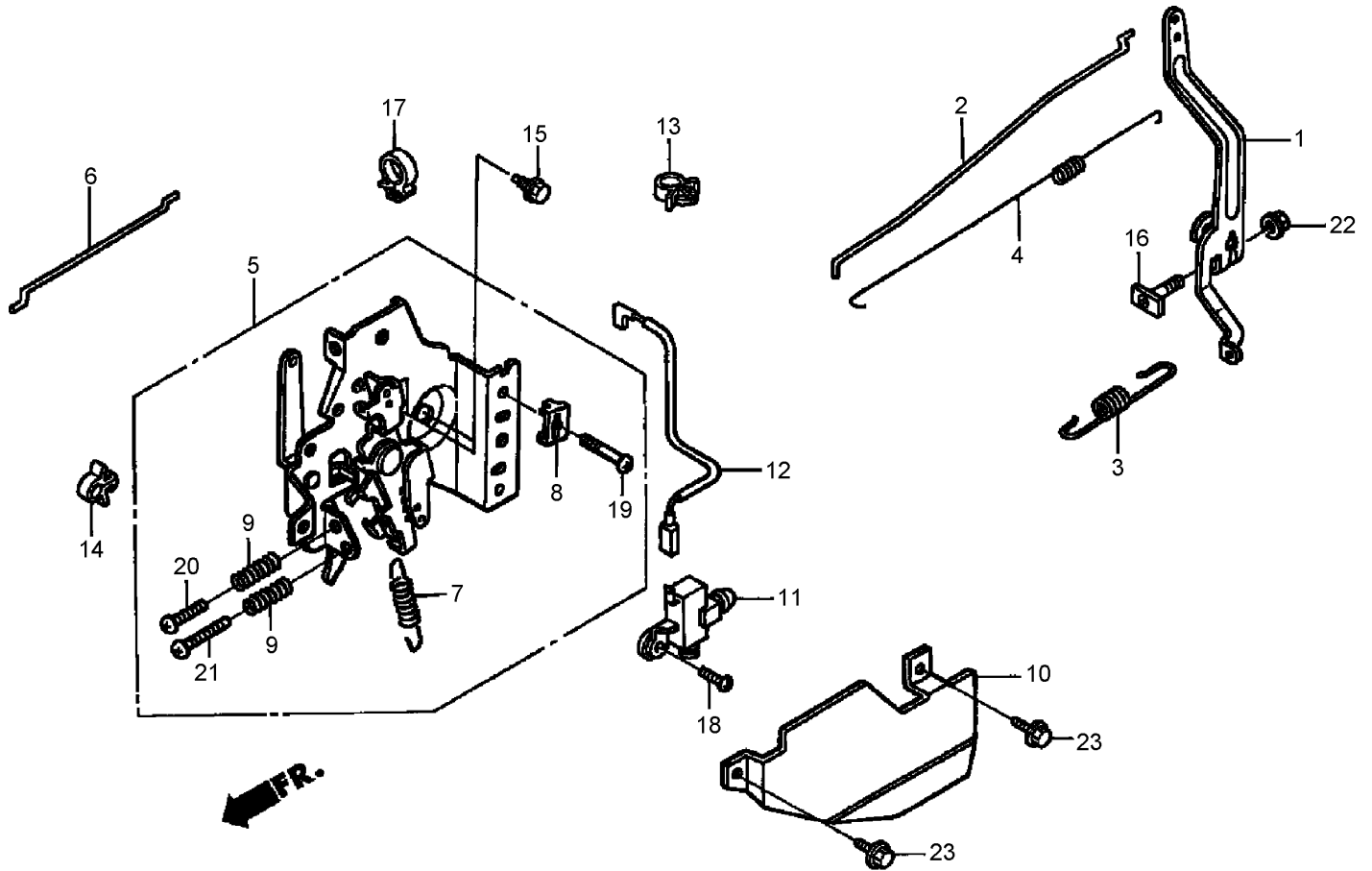

## Control Assembly Honda GXV160A1 T1AH

Ref	Part No.	Qty.	Description
①	16551-ZE7-000	1	Arm-Governor
②	16555-ZE7-000	1	Rod-Governor
③	16561-ZE7-020	1	Spring-Governor (STD)
④	16562-ZE6-000	1	Spring-Return, Throttle
⑤	16570-ZE7-020	1	Control ASM
⑥	16573-ZE7-000	1	Rod-Choke
⑦	16576-ZE7-300	1	Spring-Lever
⑧	16576-891-000	1	Holder-Cable
⑨	16584-883-300	2	Spring-Adjusting, Control
⑩	16585-ZE7-000	1	Protector-Control
⑪	36100-ZE7-013	1	Engine Stop Switch ASM
⑫	36101-ZE7-020	1	Wire-Switch, Stop
⑬	46392-SC2-003	1	Clamp-Pipe, Brake

Ref	Part No.	Qty.	Description
⑭	36103-ZE1-000	1	Holder-Wire, Stop Switch
⑮	90013-883-000	2	Bolt-Flange (6X12)
⑯	90015-ZE5-010	1	Bolt-Arm, Governor
⑰	90659-680-013	1	Clip-Harness, Wire
⑱	93500-04008-0A	1	Screw-Pan (4X8)
⑲	93500-05016-0A	1	Screw-Pan (5X16)
⑳	93500-05020-0A	1	Screw-Pan (5X20)
㉑	93500-05028-0A	1	Screw-Pan (5X28)
㉒	94050-06000	1	Nut-Flange (6Mm)
㉓	95701-06010-00	2	Bolt-Flange (6X10)

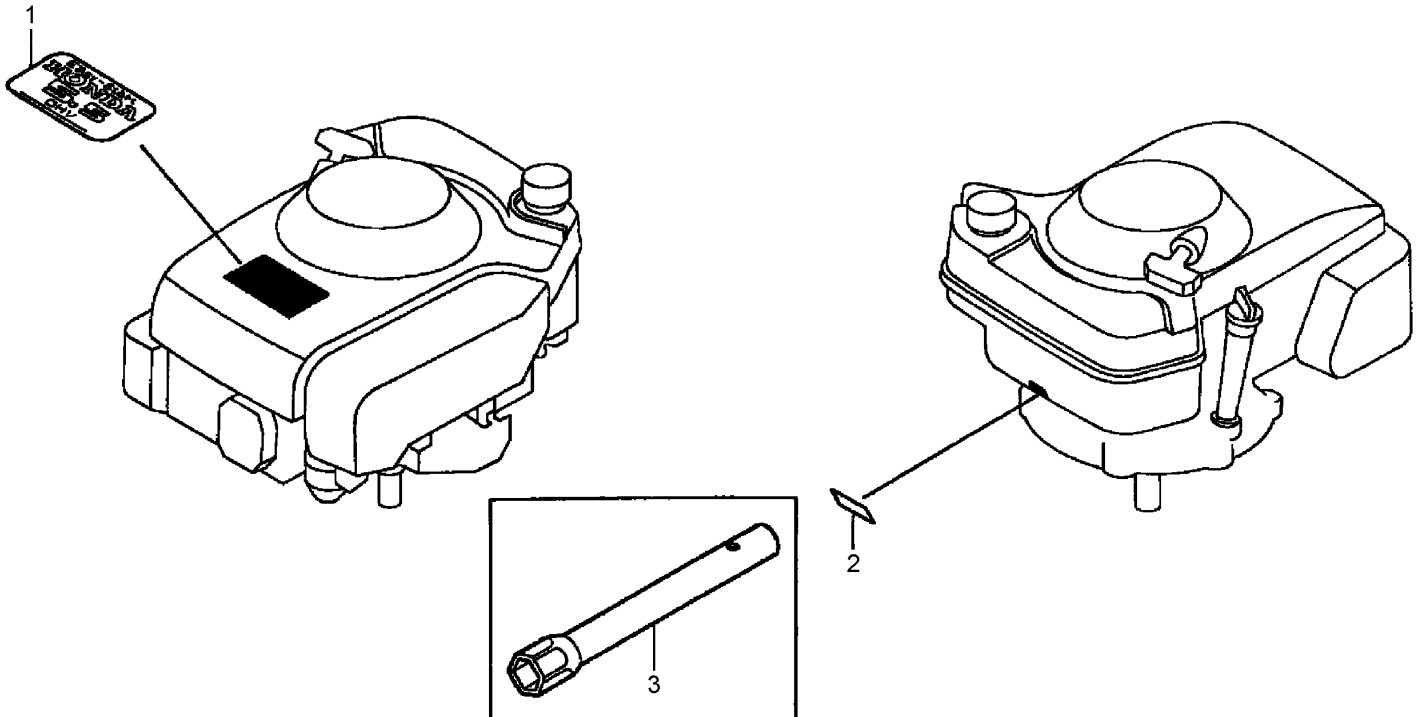

## Label Assembly Honda GXV160A1 T1AH

Ref	Part No.	Qty.	Description
①	87101-ZE7-W31	1	Emblem (5.5)
②	87601-ZE7-V20	1	Mark-Type (T1Ah)
③	99004-21003	1	Wrench-Box (P21)

--	--	--	--

