



Z400 Z Master[®] With 52in 7-Gauge Side Discharge Mower

Model No. 74410 - 250007001 and up.

Parts Catalog

Ordering Replacement Parts

To order replacement parts, please supply the part number, the quantity, and the description of each part desired.

Understanding Reference Numbers

Each Identified part in an illustration has a reference number. The reference number for a part also appears in the parts list, along with other information about the part.

This catalog uses two special reference number formats, one to indicate parts in a service assembly and another to indicate the quantity of a given part in an illustration.

Service Assembly Reference Numbers

Parts in service assemblies have reference numbers in the form a:b. The a represents the reference number of the entire service assembly and the b represents a sequential number unique to each part within the service assembly.

For example, a wheel assembly might be identified by reference number 6, the tire by 6:1, the valve by 6:2, and the wheel by 6:3. When you order the assembly identified by reference number 6, you receive all parts identified by reference numbers 6:1, 6:2, and 6:3. However, you may also order any part individually. Reference numbers of this type appear in illustrations and in part lists.

Reference Numbers Indicating Quantity

In an illustration, if a reference number indicates more than one part, the reference number has the form nX y. The n represents the quantity of the part, the X is the multiplication symbol, and the y represents the reference number.

For example, in an illustration, the reference number 2X 37 means that two of the parts identified by reference number 37 are indicated.

Contents

Description	Page	Description	Page
Front Frame Assembly 3	Cylinder and Crankcase Assembly Kawasaki FH580V-AS14 24
Height-of-Cut Assembly 4	Piston/Crankshaft Assembly Kawasaki FH580V-AS14 25
Main Frame Assembly 5	Valve and Camshaft Assembly Kawasaki FH580V-AS14 26
Fuel System Assembly 6	Lubrication Equipment Assembly Kawasaki FH580V-AS14 27
Parking Brake Assembly 7	Cooling Equipment Assembly Kawasaki FH580V-AS14 28
Motion Control Assembly 8	Electrical Equipment Assembly Kawasaki FH580V-AS14 29
Hydraulic System Assembly 9	Control Equipment Assembly Kawasaki FH580V-AS14 30
Pump Idler and Belt Assembly 11	Carburetor Assembly Kawasaki FH580V-AS14 31
Engine, Clutch and Muffler Assembly 12	Air Filter and Muffler Assembly Kawasaki FH580V-AS14 32
Deck Mounting Assembly 13	Fuel Tank and Valve Assembly Kawasaki FH580V-AS14 33
Deck Assembly No. 107-1694 14	Starter Assembly Kawasaki FH580V-AS14 34
Idler Assembly 15	Decal Assembly Kawasaki FH580V-AS14 35
Spindle Assembly No. 107-8504 16	Attachments and Accessories List 36
Deck Decal Assembly No. 107-1693 17		
Rubber Deflector Assembly No. 108-2792 18		
Electrical Assembly 19		
Seat and Bracket Assembly 20		
Seat Assembly No. 107-2116 21		
Roll-Over-Protection-System Assembly 22		
Roll-Over-Protection-System Assembly No. 107-8093 23		

Part Description Abbreviations

Part descriptions in this catalog may include the following abbreviations.

AR. as required	HWHTF. hex washer head thread forming
ASM. assembly	HYD. hydraulic
BBC. blade brake clutch	INC. incorporated
CARR. carriage	LH. left hand
DEG. degrees	NI. nylon insert
EXT. external	NPTF. national pipe thread fine
FH. flat head	PFH. phillips flat head
GA. gauge	PPH. phillips pan head
HF. hex flange	PPHTF. phillips pan head thread forming
HH. hex head	PRH. phillips round head
HHF. hex head flange	PTH. phillips truss head
HHFTF. hex head flange thread forming	PTO. power-take-off
HJ. hex jam	RH. right hand
HLH. hex lag head	ROPS. roll-over-protection-system
HOC. height-of-cut	SFH. slotted fillister head
HSBH. hex socket button head	SHH. slotted hex head
HSFH. hex socket flat head	SHWH. slotted hex washer head
HSH. hex socket head	SPH. slotted pan head
HWH. hex washer head	

Footnotes

❶ Not illustrated

❷ Obtain from your local Kawasaki dealer

❸ Not serviced separately

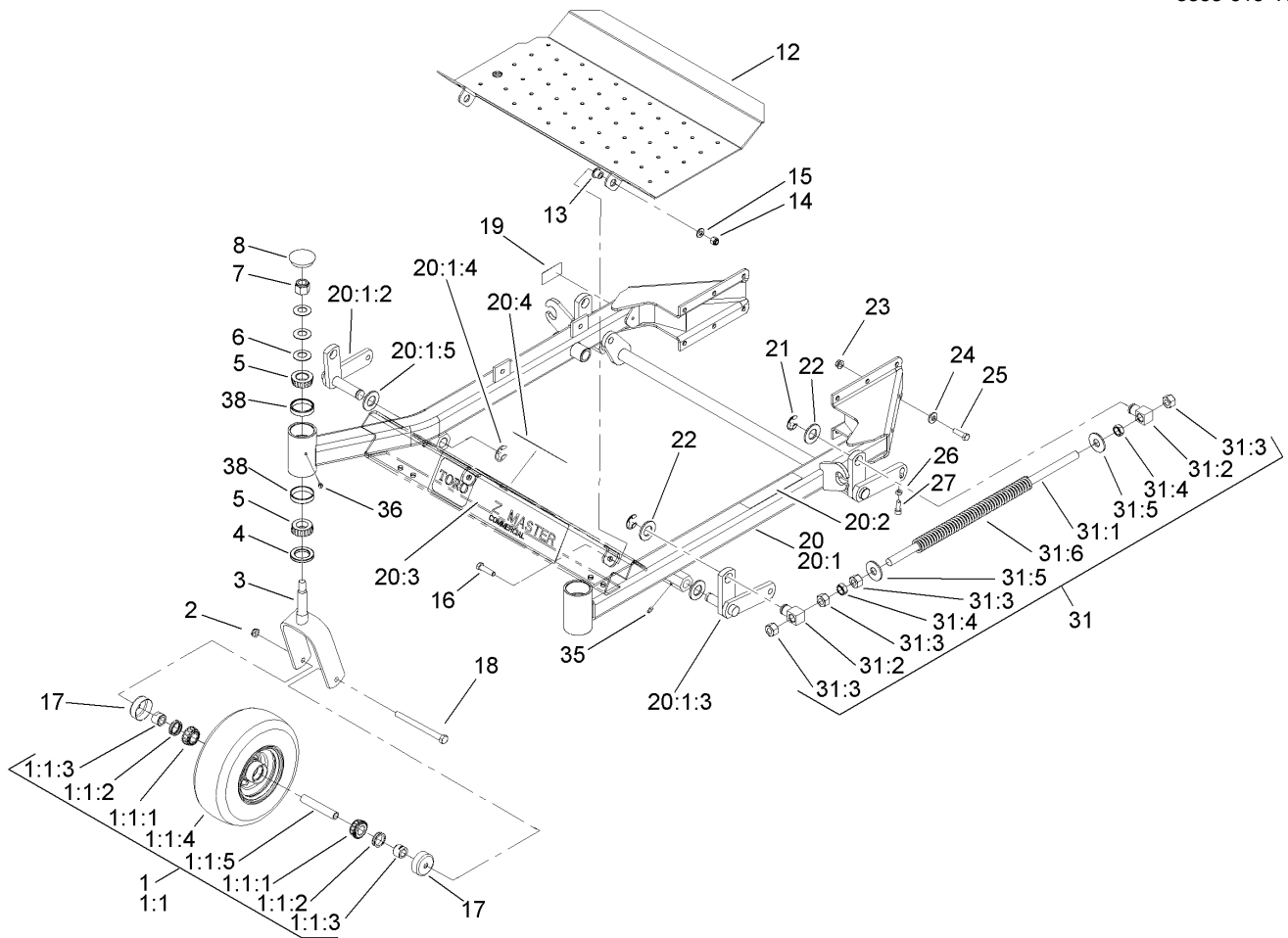

Front Frame Assembly

Ref	Part No.	Qty.	Description
1	103-3800	2	Wheel And Tire ASM
② 1:1		1	Wheel And Bearing ASM
1:1:1	1-633585	2	Bearing-Cone, Taper
1:1:2	103-0063	2	Seal-Caster
1:1:3	103-3051	2	Spacer-Nut
1:1:4	103-3151	1	Wheel And Tire ASM
1:1:5	103-3157	1	Axle-Caster
2	3296-45	2	Nut-Lock, NI
3	108-7724-01	2	Caster Fork ASM
4	1-543511	2	Seal-Grease
5	254-94	4	Bearing-Cone, Tapered
6	1-633508	6	Washer-Bellville
7	3296-51	2	Nut-Lock, NI
8	103-4882	2	Cap-Grease
12	108-5007-03	1	Floor Pan
13	86-2180	2	Bushing-Flange
14	3296-39	2	Nut-Lock, NI
15	3256-24	2	Washer-Flat
16	323-8	2	Screw-HH
17	103-2768	4	Guard-Seal
18	325-20	2	Screw-HH
19	105-2625	1	Decal-STD, Safety
20	108-7744	1	Front Frame ASM
② 20:1		1	Frame-Front

Ref	Part No.	Qty.	Description
20:1:2	99-3872-01	1	RH Lift Arm ASM
20:1:3	99-3871-01	1	LH Lift Arm ASM
20:1:4	32151-103	2	Ring-Snap
20:1:5	3256-29	2	Washer-Flat
20:2	1-633818	1	Decal-Warning
20:3	106-9730	1	Decal
20:4	107-2112	1	Decal-Warning
21	32151-103	4	Ring-Snap
22	3256-29	4	Washer-Flat
23	3290-357	12	Nut-HHF
24	98-5975	12	Washer-Bellville
25	323-7	12	Screw-HH
26	3218-2	2	Nut-Jam
27	3274-18	2	Screw-HSH
31	1-634439	2	Front Frame Spring ASM
31:1	1-633096	1	Rod-Lift, Deck
31:2	1-633441	2	Swivel-Deck Mount, Rear
31:3	3217-11	4	Nut-Hex
31:4	3218-6	2	Nut-Jam
31:5	3256-7	2	Washer-Flat
31:6	1-633064	1	Spring-Support, Deck
35	302-19	4	Fitting-Grease
36	302-5	2	Fitting-Grease
38	254-72	4	Bearing-Cup, Tapered

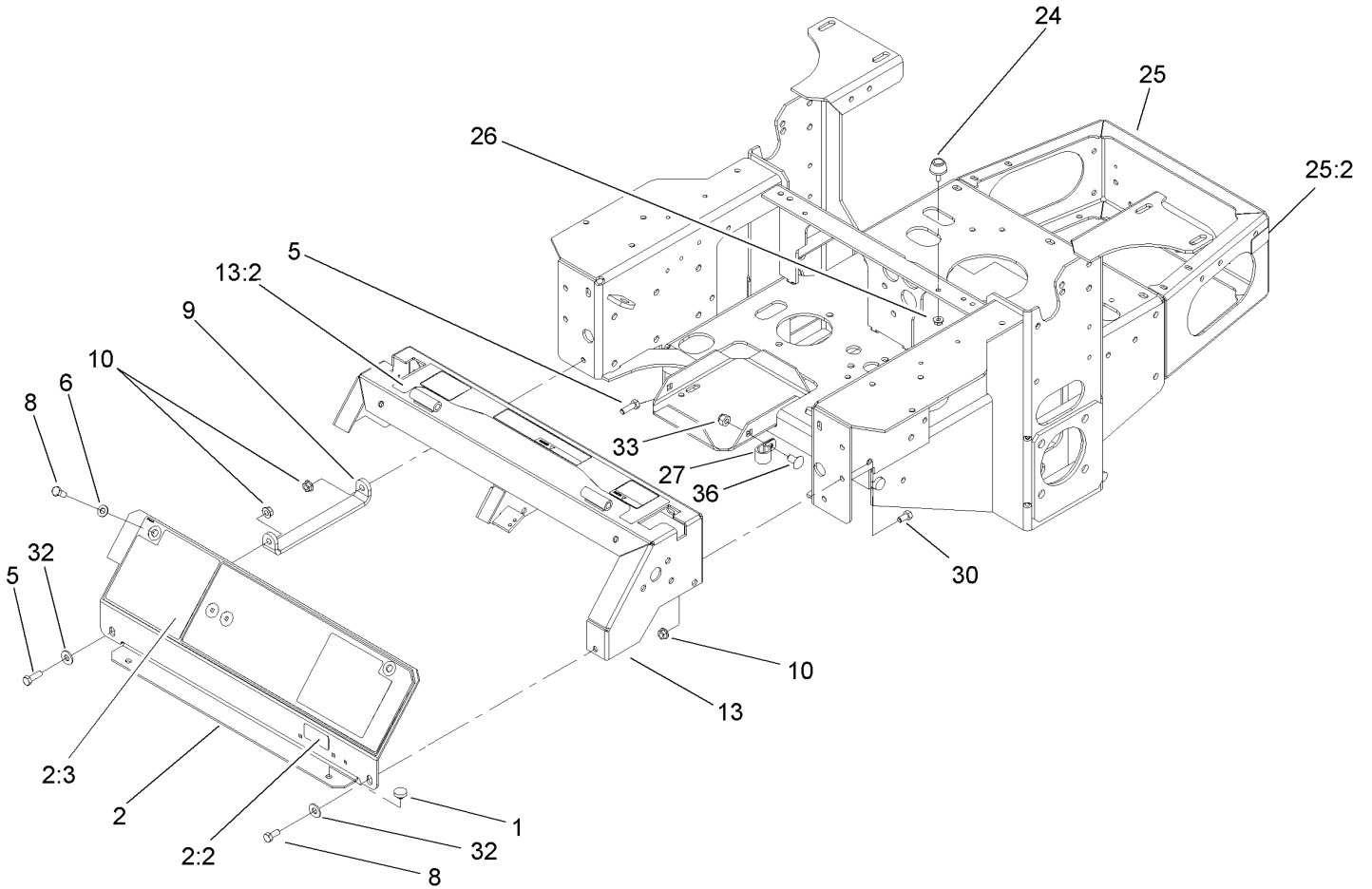

Main Frame Assembly

Ref	Part No.	Qty.	Description
1	1-513658	2	Bumper
2	108-1864	1	Panel ASM
2:2	98-4387	1	Decal-Protection, Ear
2:3	107-8445	1	Decal-Cover, Panel
5	322-5	2	Screw-HH
6	3256-23	2	Washer-Flat
8	322-3	3	Screw-HH
9	1-653089-03	1	Bracket
10	32128-20	6	Nut-HF
13	108-5997	1	Console ASM
13:2	108-5995	1	Decal-Warning
24	1-523420	2	Bumper
25	108-2782	1	Main Frame ASM
25:2	65-2690	1	Decal-Surface, Hot
26	32128-33	2	Nut-HF
27	1-633396	1	Clip-Loom
30	322-2	4	Screw-HH
32	3256-3	2	Washer-Flat
33	3296-39	1	Nut-Lock, NI
36	3231-21	1	Screw-CARR

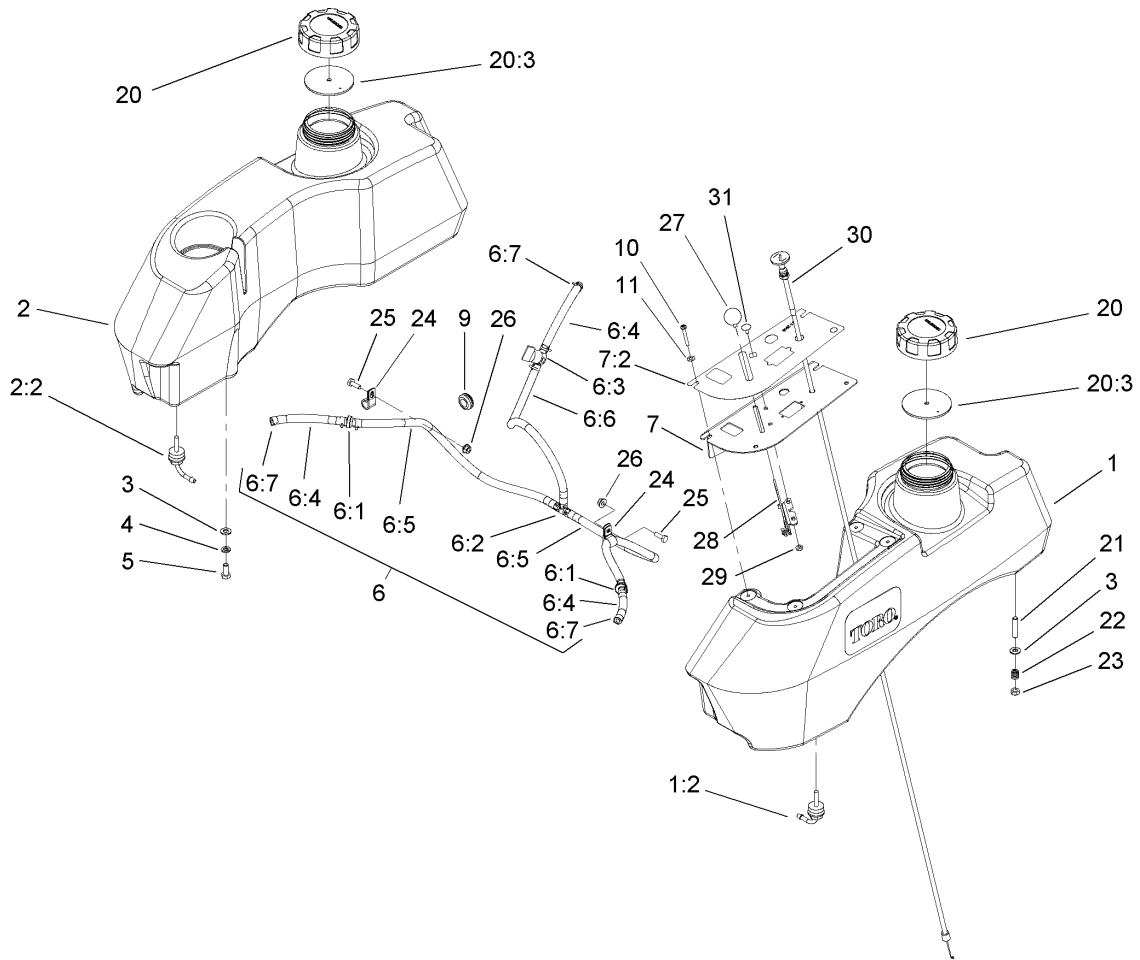

Fuel System Assembly

Ref	Part No.	Qty.	Description
1	107-2146	1	LH Fuel Tank ASM
1:2	103-2605	1	Fitting-Fuel, Bulkhead
2	106-9975	1	RH Fuel Tank ASM
2:2	103-2605	1	Fitting-Fuel, Bulkhead
3	3256-23	8	Washer-Flat
4	1-805005	4	Washer-Lock
5	322-3	4	Screw-HH
6		1	Fuel Line ASM
6:1	99-5000	2	Valve-Check, Fuel
6:2	99-5005	1	Fitting-Tee, Barbed
6:3	1-603770	1	Valve-Fuel
6:4	99-7190	3	Hose-Fuel
6:5	99-3185	2	Hose-Fuel
6:6	106-8720	1	Hose-Fuel
6:7	1-303077	12	Clamp
7	107-2149	1	Control Panel ASM
7:2	107-2148	1	Decal-Panel, Control
9	1-543296	2	Grommet
10	32122-30	4	Screw-PTH
11	1-303435	4	Washer-Spring
20	88-3980	2	Gas Cap ASM
20:3	88-4010	1	Gasket-Cap, Gas
21	1-633023	4	Stud
22	1-633349	4	Spring-Tank, Fuel

Ref	Part No.	Qty.	Description
23	3296-47	4	Nut-Lock, NI
24	1-513762	4	Clip-Loom
25	321-4	2	Screw-HH
26	32128-33	2	Nut-HF
27	1-513592	1	Knob-Ball
28	1-633696	1	Throttle Cable ASM
29	3296-2	2	Nut-Lock
30	1-603336	1	Control-Choke
31	1-807513	2	Bolt-CARR

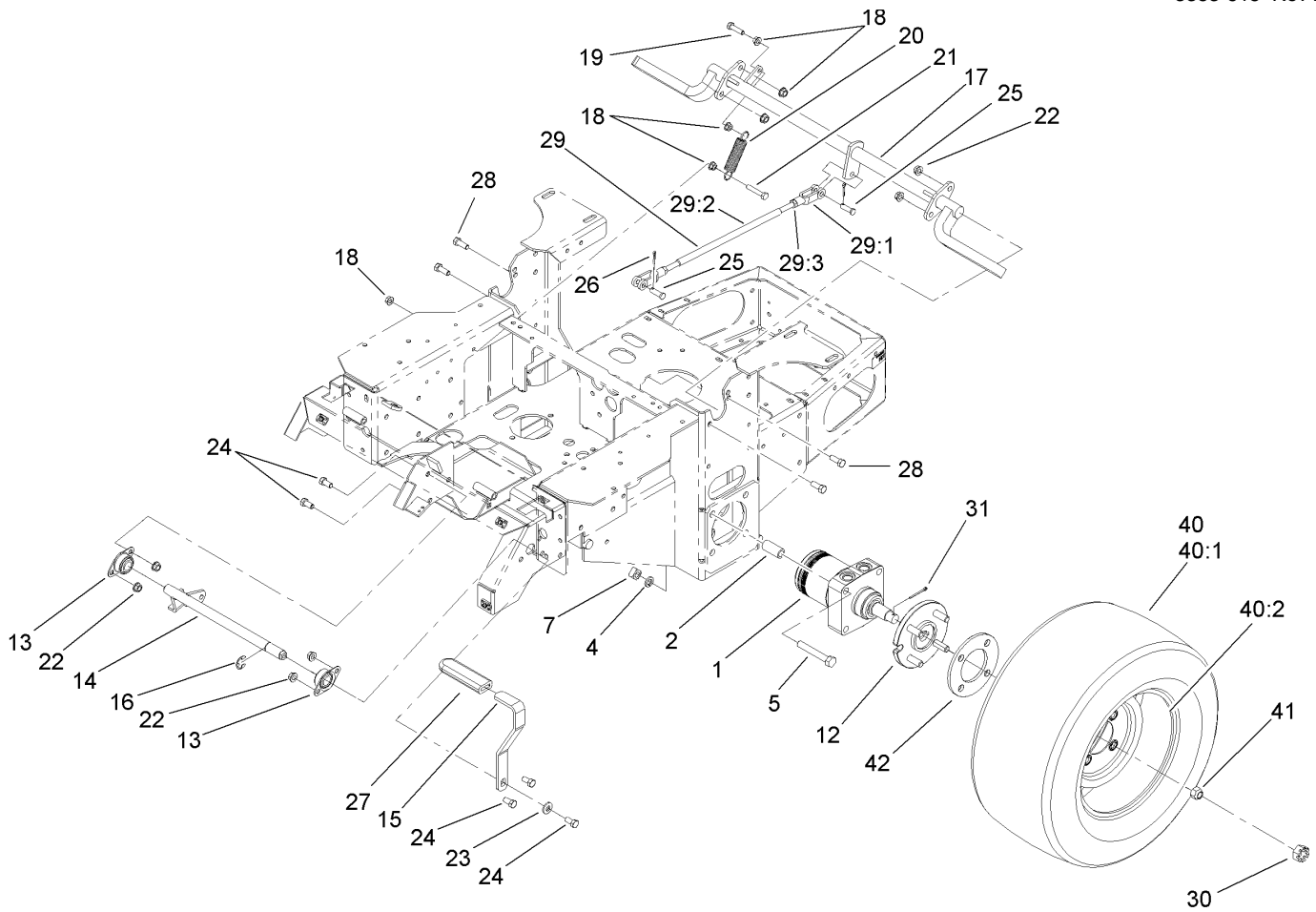

Parking Brake Assembly

Ref	Part No.	Qty.	Description
1	103-4695	2	Motor-Wheel
❶:1	1-000119	1	Seal Kit
❶:2	1-000138	1	Bearing Kit
2	103-4042	8	Spacer-Motor, Wheel
4	3253-7	8	Washer-Lock
5	325-18	8	Screw-HH
7	103-0131	8	Nut-Square
12	1-602997	2	Hub W/Studs
13	1-633102	2	Bearing-Flange, Side
14	103-3116	1	Shaft-Brake, Parking
15	1-653074-03	1	Handle-Brake, Park
16	32151-48	1	E-Ring
17	103-3960-03	1	Brake
18	32128-20	4	Nut-HF
19	322-6	1	Screw-HH
20	1-323161	1	Spring-Idler
21	322-9	1	Screw-HH
22	3290-357	8	Nut-HHF
23	98-5975	1	Washer-Belleville
24	323-4	5	Screw-HH
25	1-808285	2	Pin-Clevis
26	3272-10	2	Pin-Cotter
27	1-633268	1	Grip-Lever, Brake
28	323-6	4	Screw-HH

Ref	Part No.	Qty.	Description
29	103-4335	1	Brake Rod ASM
29:1	1-633131	2	Yoke-Linkage, Brake
29:2	103-3907	1	Linkage-Handle, Brake
29:3	3219-3	2	Nut-Hex
30	32136-5	2	Nut-Hex, Slotted
31	1-806800	2	Pin-Cotter
40	1-543396	2	Wheel And Tire ASM
40:1	1-543680	1	Tire
40:2	1-513042	1	Wheel
41	242-50	8	Nut-Lug
42	103-6595	2	Spacer-Wheel

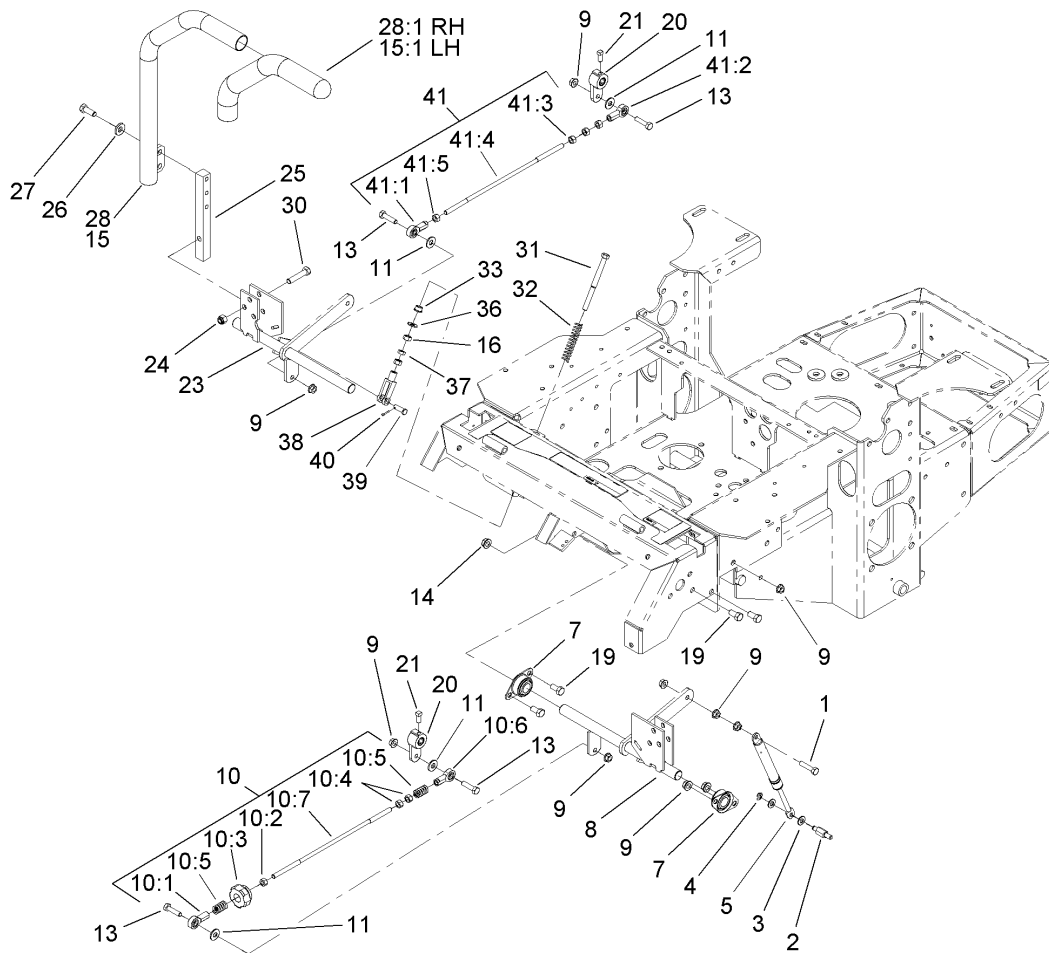

Motion Control Assembly

Ref	Part No.	Qty.	Description
1	1-403180	2	Screw-HH
2	103-4101	2	Pin-Damper
3	3256-23	4	Washer-Flat
4	32120-35	2	E-Ring
5	103-4079	2	Damper-Control, Motion
7	1-633102	4	Bearing-Flange, Side
8	103-4774	1	Control-Motion, LH
9	32128-20	12	Nut-HF
10	103-4326	1	Tracking Rod ASM
10:1	1-543017	1	Balljoint-RH
10:2	3219-2	1	Nut-Hex
10:3	103-3060	1	Knob-Tracking
10:4	1-804524	2	Nut
10:5	1-323245	2	Spring-Compression
10:6	1-633152	1	Balljoint-Thread, LH
10:7	103-3066	1	Link-Rod, Tracking
11	3256-3	4	Washer-Flat
13	322-6	4	Screw-HH
14	3290-357	6	Nut-HHF
15	103-0631	1	LH Lever ASM
15:1	1-633257	1	Grip-Control, Motion
16	3219-2	4	Nut-Hex
19	323-4	6	Screw-HH
20	103-3717	2	Arm-Control

Ref	Part No.	Qty.	Description
21	1-803022	2	Screw-Set
23	103-4773	1	Control-Motion, RH
24	3296-39	6	Nut-Lock, NI
25	103-0407	2	Arm-Shaft, Control
26	98-5975	4	Washer-Belleville
27	323-6	4	Screw-HH
28	103-0632	1	RH Lever ASM
28:1	1-633257	1	Grip-Control, Motion
30	323-9	6	Screw-HH
31	1-603737	2	Bolt-Return, Neutral
32	1-603807	2	Spring-Return, Neutral
33	1-603735	2	Bushing-Flanged
36	3256-2	2	Washer-Flat
37	3220-2	2	Nut-Jam
38	1-303105	2	Yoke-Adjustable
39	1-808280	2	Pin-Clevis
40	3272-5	2	Pin-Cotter
41	103-4327	1	Tracking ASM
41:1	1-543017	1	Balljoint-RH
41:2	1-633152	1	Balljoint-Thread, LH
41:3	1-804524	1	Nut
41:4	103-3066	1	Link-Rod, Tracking
41:5	3219-2	3	Nut-Hex

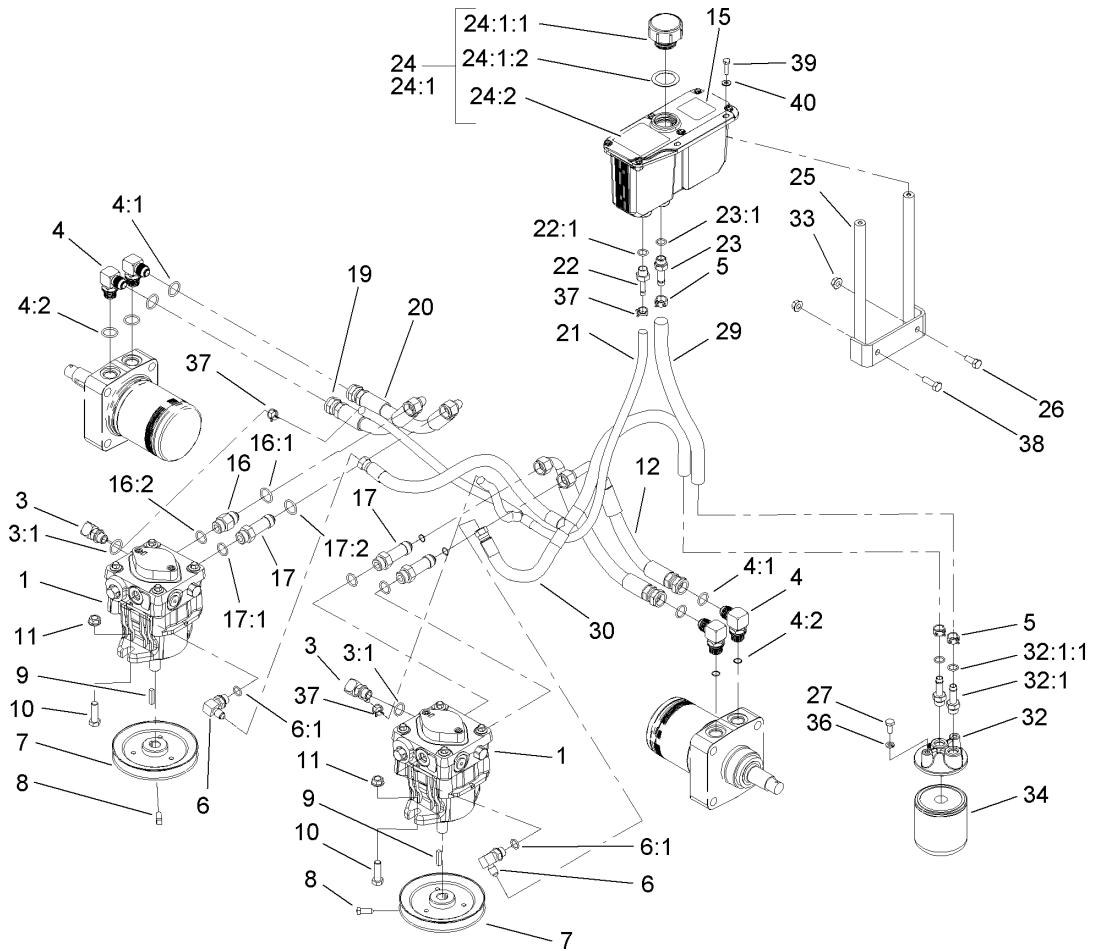

Hydraulic System Assembly

Ref	Part No.	Qty.	Description
1	103-4040	2	Pump-HYD
3	103-1799	2	Elbow-90 DEG
3:1	237-42	1	O-Ring
4	103-2153	4	Fitting-90 DEG
4:1	1-603920	1	O-Ring
4:2	1-603992	1	O-Ring
5	103-1988	3	Clamp-Hose
6	103-1802	2	Fitting-HYD, 90 DEG
6:1	1-603921	1	O-Ring
7	1-653156	2	Pulley
8	1-803050	2	Screw-Set
9	1-807272	2	Key
10	323-7	4	Screw-HH
11	3290-357	5	Nut-HHF
12	103-4022	1	Hose-Rear, LH
15	103-2644	1	Decal-Exhaust
16	103-4020	1	Adapter-Straight
16:1	1-603920	1	O-Ring
16:2	1-603992	1	O-Ring
17	103-1940	3	Adapter-HYD, Straight
17:1	237-79	1	O-Ring
17:2	1-603992	1	O-Ring
19	103-4021	1	Hose-Rear, RH
20	1-653187	2	Hose-Rear, RH

Ref	Part No.	Qty.	Description
21	103-2357	1	HYD Hose ASM
22	103-1801	1	Adapter-Straight
22:1	237-42	1	O-Ring
23	103-1912	1	Adapter-Straight
23:1	237-42	1	O-Ring
24	103-1947	1	HYD Reservoir ASM
24:1		1	Reservoir-HYD
24:1:1	103-1948	1	Cap-Reservoir, HYD
24:1:2	103-1949	1	Gasket-Cap
24:2	1-523552	1	Decal-Tank, HYD
25	103-3071-03	1	Stand-Reservoir
26	322-3	1	Screw-HH
27	321-3	2	Screw-HH
29	103-3077	1	HYD Hose ASM
30	103-2930	1	HYD Hose ASM
32	103-2889	1	Filter Head ASM
32:1	103-1912	2	Adapter-Straight
32:1:1	237-42	1	O-Ring
33	32128-20	2	Nut-HF
34	1-633752	1	Filter-HYD, Winter
34	1-633750	1	Filter-HYD
36	1-805004	2	Washer-Lock
37	103-1716	3	Clamp-Hose
38	322-5	1	Screw-HH

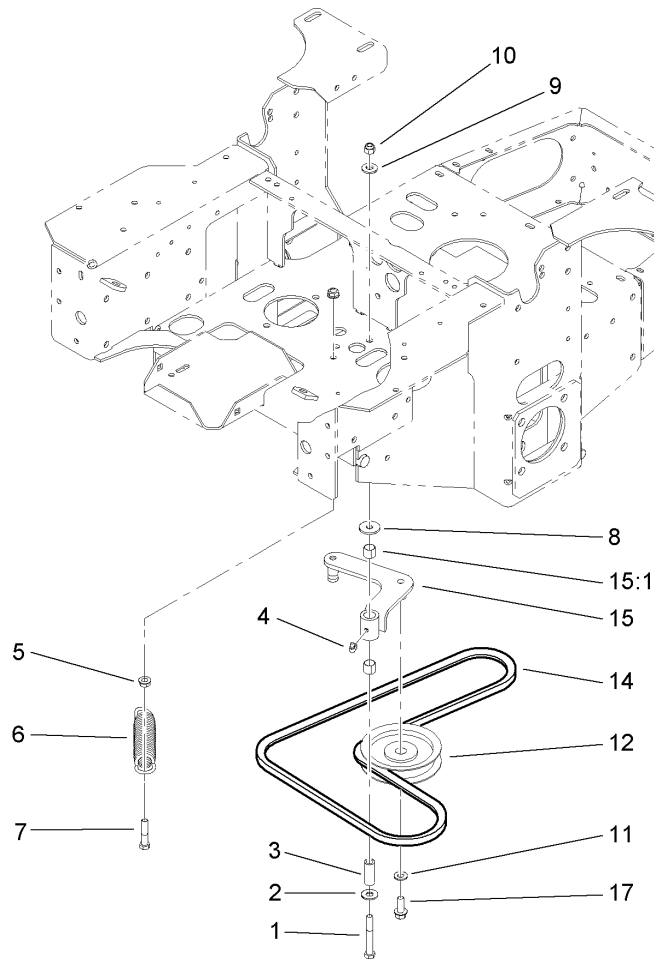

Pump Idler and Belt Assembly

Ref	Part No.	Qty.	Description
1	323-13	1	Screw-HH
2	3256-4	1	Washer-Flat
3	1-603044	1	Bushing
4	302-40	1	Fitting-Grease
5	3290-357	2	Nut-HHF
6	103-4480	1	Spring-Extension
7	323-9	1	Screw-HH
8	63-8410	1	Washer
9	98-5975	1	Washer-Belleville
10	3296-39	1	Nut-Lock, NI
11	3256-24	1	Washer-Flat
12	1-603843	1	Pulley-Idler
14	107-3959	1	Belt-Cog
15	103-4482	1	Idler Arm ASM
15:1	103-4681	2	Sleeve-Bearing
17	3234-11	1	Screw-HHF

--	--	--	--

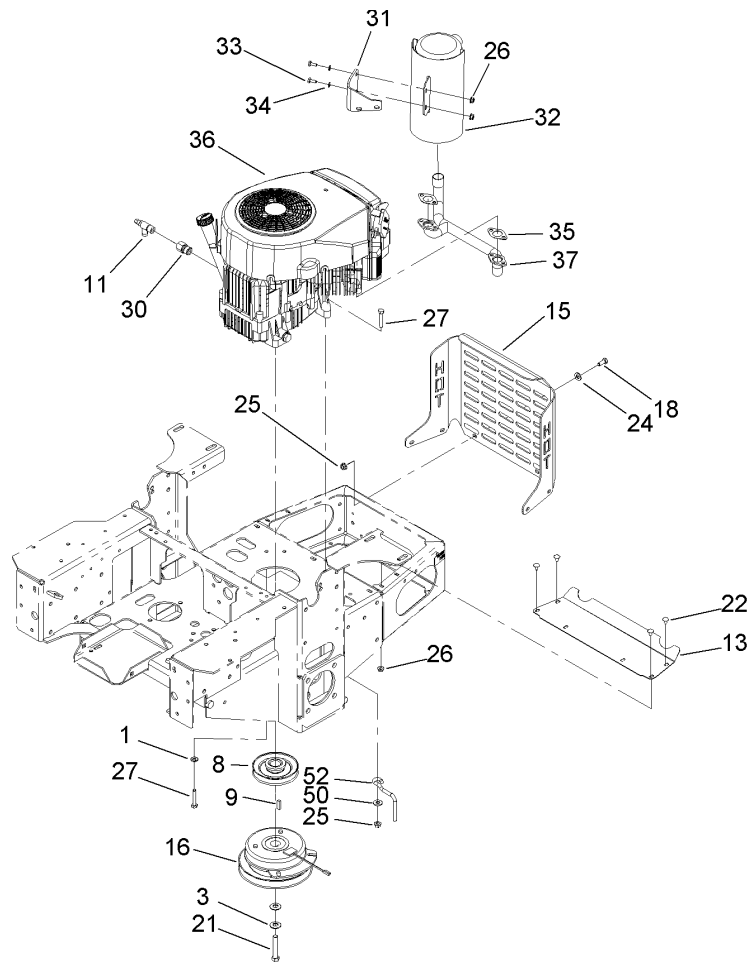

Engine, Clutch and Muffler Assembly

Ref	Part No.	Qty.	Description
1	1-303334	4	Washer-Spring
3	1-603610	2	Washer-Spring
8	1-653035	1	Pulley
9	1-807259	1	Key
11	103-1965	1	Valve-Drain, Oil
13	103-2740-03	1	Deflector-Short
15	103-4048-03	1	Bumper-Rear
16	104-3624	1	Clutch
18	322-3	6	Screw-HH
21	3212-10	1	Screw-HH
22	3229-10	4	Screw-CARR
24	3256-24	6	Washer-Flat
25	32128-20	11	Nut-HF
26	32128-33	6	Nut-HF
27	322-9	5	Screw-HH
30	103-1966	1	Adapter
31	103-4578-03	1	Bracket-Muffler
32	103-5298	1	Muffler
33	321-3	2	Screw-HH
34	1-303435	2	Washer-Spring
35	1-653290	2	Gasket
36		1	Engine-Kawasaki, FH580V-As14
37	103-4577	1	Manifold-Exhaust
50	3256-3	1	Washer-Flat

Ref	Part No.	Qty.	Description
52	108-1058	1	Rod-Belt

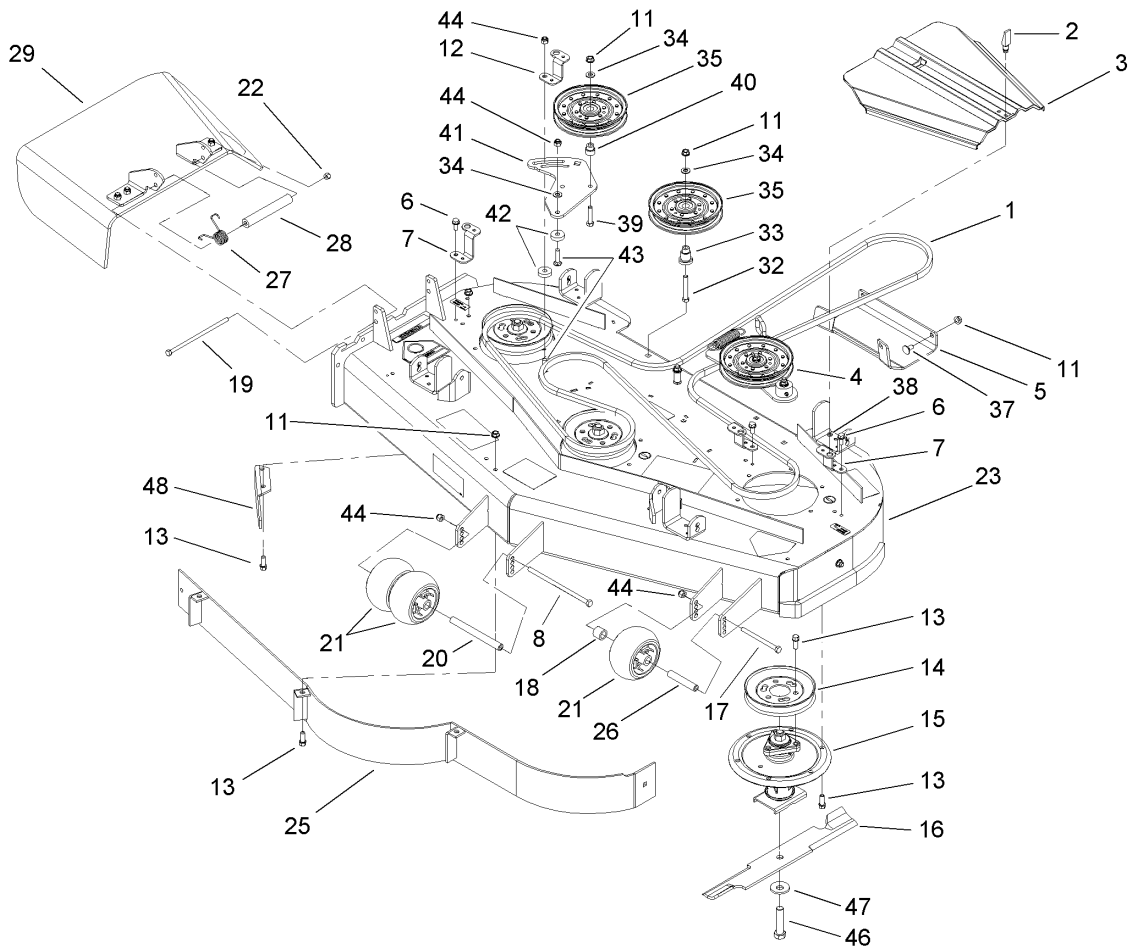

Deck Assembly No. 107-1694

Ref	Part No.	Qty.	Description
1	106-7369	1	Belt-V
2	74-5950	2	Latch-Swell
3	107-8536	2	Cover-Belt
4		1	Spring Idler ASM
5	106-7358-01	1	Plate-Skid
6	32144-70	3	Screw-HH
7	108-2177-01	4	Bracket-Cover, Tall
8	323-28	1	Screw-HH
11	3290-357	36	Nut-HHF
12	108-2178-01	1	Bracket-Cover, Short
13	92-1624	32	Screw
14	107-1683	3	Pulley
15	107-8504	3	Spindle ASM
16	105-7781-03	3	Blade-Hi Flow
17	323-23	1	Screw-HH
18	98-7913	1	Tube-Spacer
19	322-50	1	Screw-HH
20	98-5967	1	Spacer-Wheel
21	1-603299	3	Roller-Scalp, Anti
22	3296-29	1	Nut-Lock, NI
23	107-1693	1	Deck Decal ASM
25	108-2185-01	1	Baffle ASM
26	98-7912	1	Tube-Spanner
27	108-4052	1	Spring-Torsion

Ref	Part No.	Qty.	Description
28	105-4622	1	Spacer
29	108-2792	1	Rubber Deflector ASM
32	323-12	1	Screw-HH
33	106-3214	1	Mount-Pulley
34	3256-24	3	Washer-Flat
35	1-633109	2	Idler-Flat
37	3231-1	11	Screw-CARR
38	99-3058	2	Washer
39	323-9	1	Screw-HH
40	1-603496	1	Bushing-Idler
41	107-8516-01	1	Plate-Idler
42	105-7788	2	Spacer
43	3231-4	2	Screw-CARR
44	3296-39	4	Nut-Lock, NI
46	103-0862	3	Screw-Cap
47	103-0865	3	Washer-Blade Bolt, Heavy
48	106-3216-01	1	Baffle-Discharge

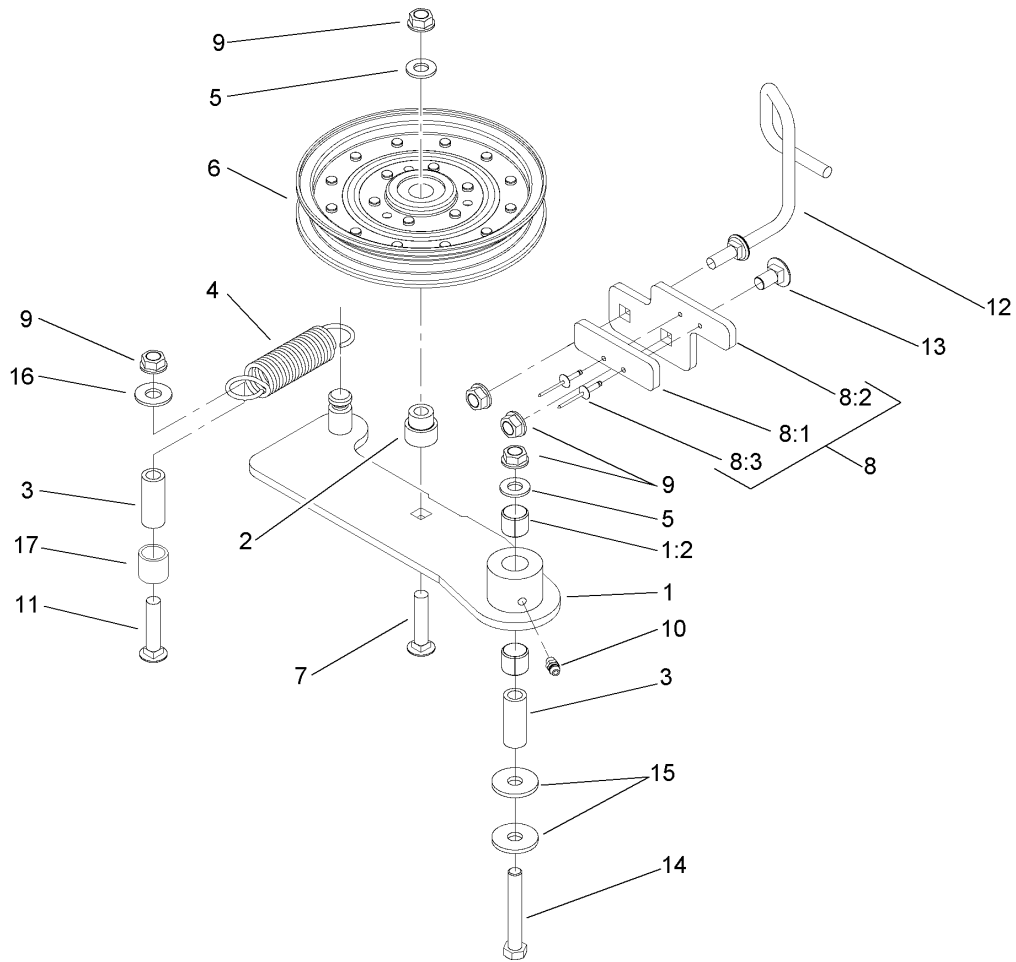

Idler Assembly

Ref	Part No.	Qty.	Description
1	108-4062	1	Idler Arm ASM
1:2	103-4681	2	Sleeve-Bearing
2	1-603496	1	Bushing-Idler
3	1-603044	2	Bushing
4	108-4056	1	Spring-Extension
5	3256-24	2	Washer-Flat
6	1-633109	1	Idler-Flat
7	3231-6	1	Screw-CARR
8		1	Stop Pad ASM
8:1	106-3229	1	Pad-Bumper
8:2	107-1697-01	1	Plate-Stop
8:3	3269-24	2	Rivet
9	3290-357	5	Nut-HHF
10	302-5	1	Fitting-Grease
11	3231-31	1	Screw-CARR
12	108-4072	1	Guide-Belt
13	3231-1	1	Screw-CARR
14	323-12	1	Screw-HH
15	2844	2	Washer
16	3256-4	1	Washer-Flat
17	108-4063	1	Spacer-Rubber

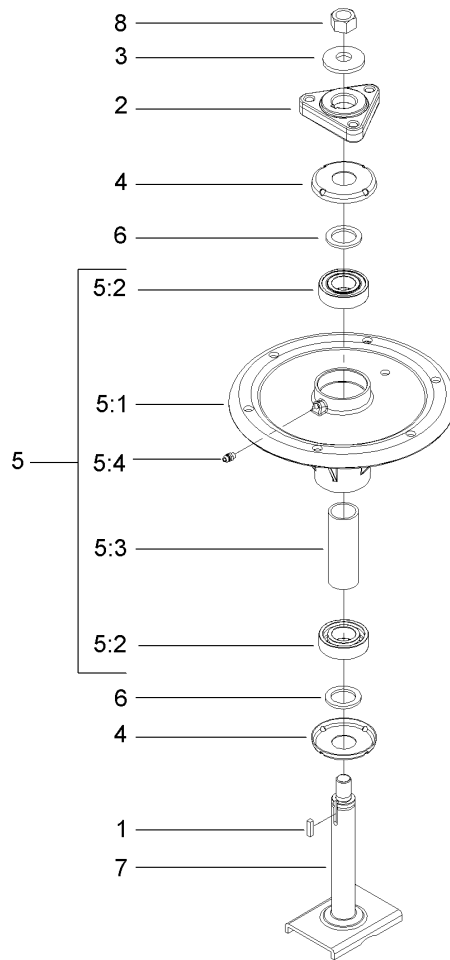

Spindle Assembly No. 107-8504

Ref	Part No.	Qty.	Description
1	10-8040	1	Key-Square
2	106-3277	1	Hub-Pulley
3	103-0865	1	Washer-Blade Bolt, Heavy
4	106-3204	2	Shield-Bearing
5		1	Spindle Bearing ASM
5:1	106-3211	1	Housing-Spindle
5:2	113514	2	Bearing-Ball
5:3	107-8502	1	Spacer-Bearing
5:4	302-5	1	Fitting-Grease
6	3-8514	2	Washer-Thrust
7	107-8501	1	Spindle ASM
8	3219-6	1	Nut-Hex

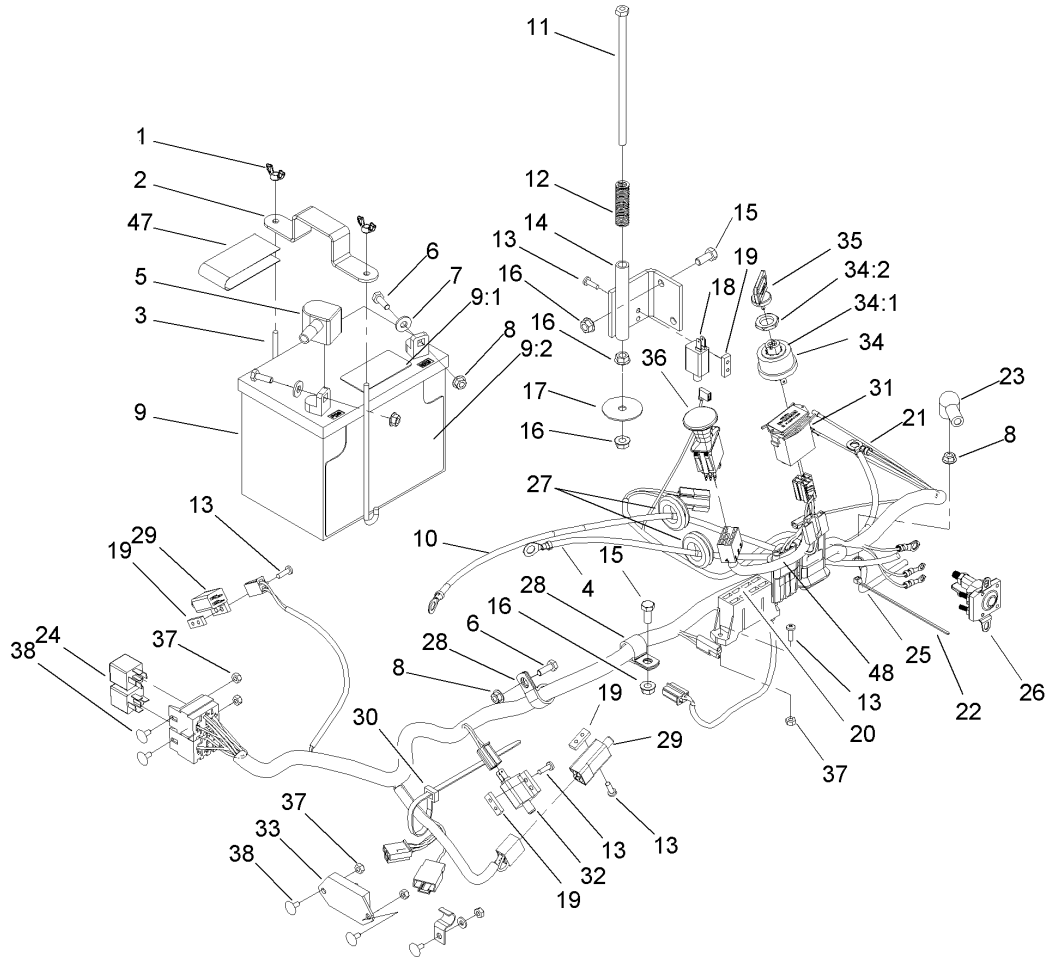

Electrical Assembly

Ref	Part No.	Qty.	Description
1	1-543792	2	Wingnut
2	1-633652-03	1	Strap-Holddown
3	1-633651	2	Bolt-Holddown
4	103-0705	1	Cable-Ground, Negative
5	1-543391	1	Insulator-Battery
6	321-4	5	Screw-HH
7	3256-2	2	Washer-Flat
8	32128-33	6	Nut-HF
9	105-1692	1	Battery
9:1	104-4163	1	Decal-Battery
9:2	104-4164	1	Decal-Battery
10	103-0707	1	Cable-Battery, Positive
11	1-800282	1	Screw-HH
12	1-523415	1	Spring-Switch, Seat
13	1-803075	10	Screw-Head, Truss
14	1-652072-03	1	Bracket-Switch, Seat
15	322-3	3	Screw-HH
16	32128-20	5	Nut-HF
17	1-653036	1	Washer
18	1-513152	1	Switch-Closed, Normally
19	1-633181	4	Plate-Tapped
20	1-816001	2	Fuse-Blade Type, 20 Amp
21	107-8051	1	Harness-Electrical
22	1-303287	4	Tie-Plastic

Ref	Part No.	Qty.	Description
23	1-543393	3	Insulator-Solenoid
24	1-643275	2	Relay
25	1-633306	1	Wire-Starter
26	1-513075	1	Switch-Solenoid
27	1-543286	3	Grommet
28	1-633396	2	Clip-Loom
29	1-513051	2	Switch-Open, Normally
30	1-303335	4	Tie-Plastic
31	1-513374	1	Meter-Hour
32	1-633111	1	Switch
33	100-6186	1	Module-Delay, Seat
34	88-9830	1	Key Switch ASM
34:1	3254-5	1	Washer-Tooth
34:2	218-461	1	Nut-HH
35	63-8360	2	Key-Ignition
36	1-633673	1	Switch-Delta
37	3296-2	6	Nut-Lock
38	1-807513	4	Bolt-CARR
47	107-9309	1	Decal-Instructions, Charging
48	107-8054	1	Harness-Electrical, Control Panel

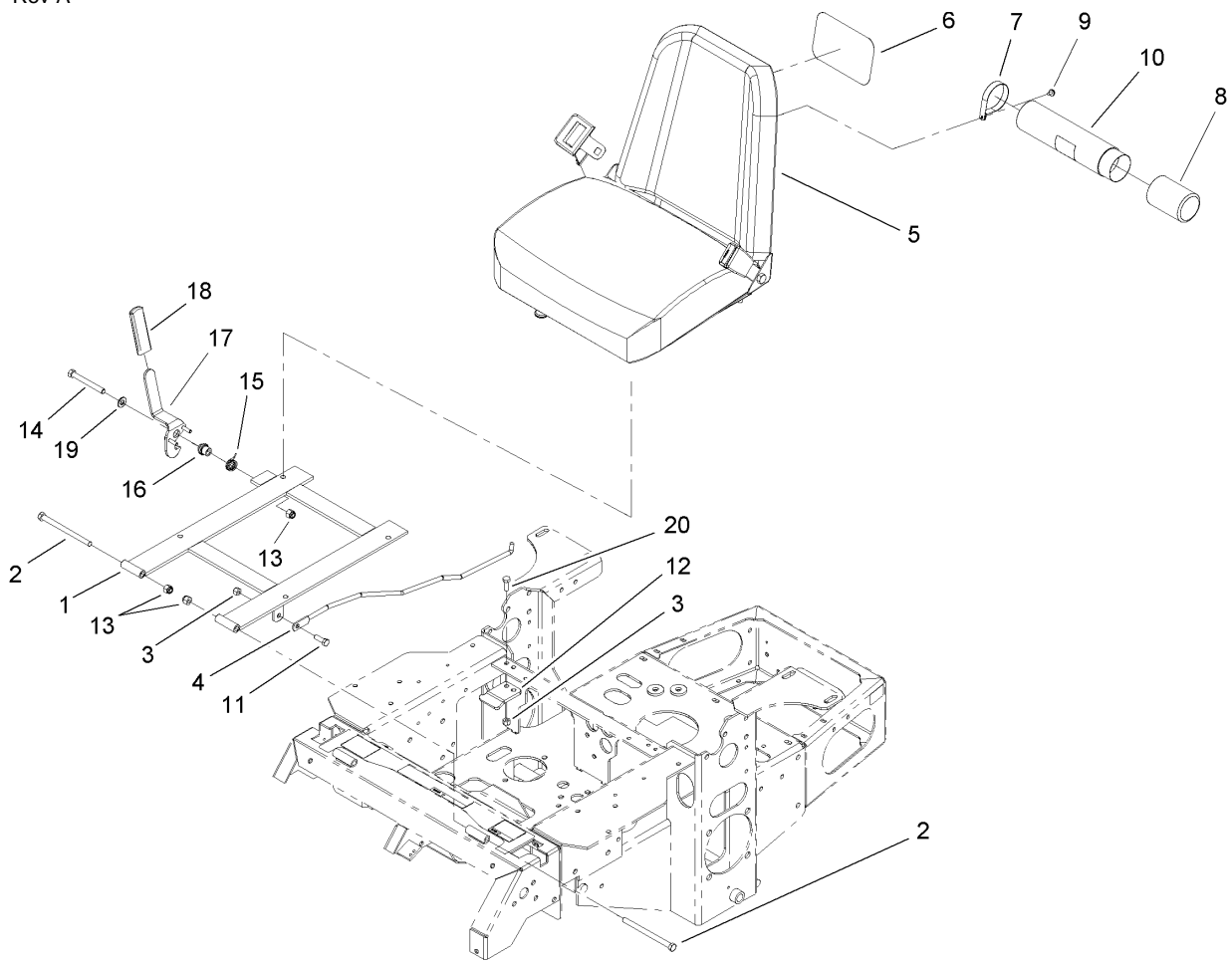

Seat and Bracket Assembly

Ref	Part No.	Qty.	Description
1	107-3052-03	1	Seat Support Frame ASM
2	323-39	2	Screw-HH
3	3296-29	3	Nut-Lock, NI
4	103-1731	1	Rod-Retainer, Seat
5	107-2116	1	Seat ASM
6	99-4693	1	Decal
7	2412-120	2	R-Clamp
8	104-7048	1	Cap-Housing
9	32104-76	2	Screw
10	104-7050	1	Housing-Manual
11	322-5	1	Screw-HH
12	103-5961	1	Catch-Latch, Seat
13	3296-39	3	Nut-Lock, NI
14	323-20	1	Screw-HH
15	107-0076	1	Spring-Torsion
16	107-0075	1	Bushing-Latch, Seat
17	107-3083	1	Latch ASM
18	103-4434	1	Grip-Lever
19	3256-24	1	Washer-Flat
20	322-4	2	Screw-HH

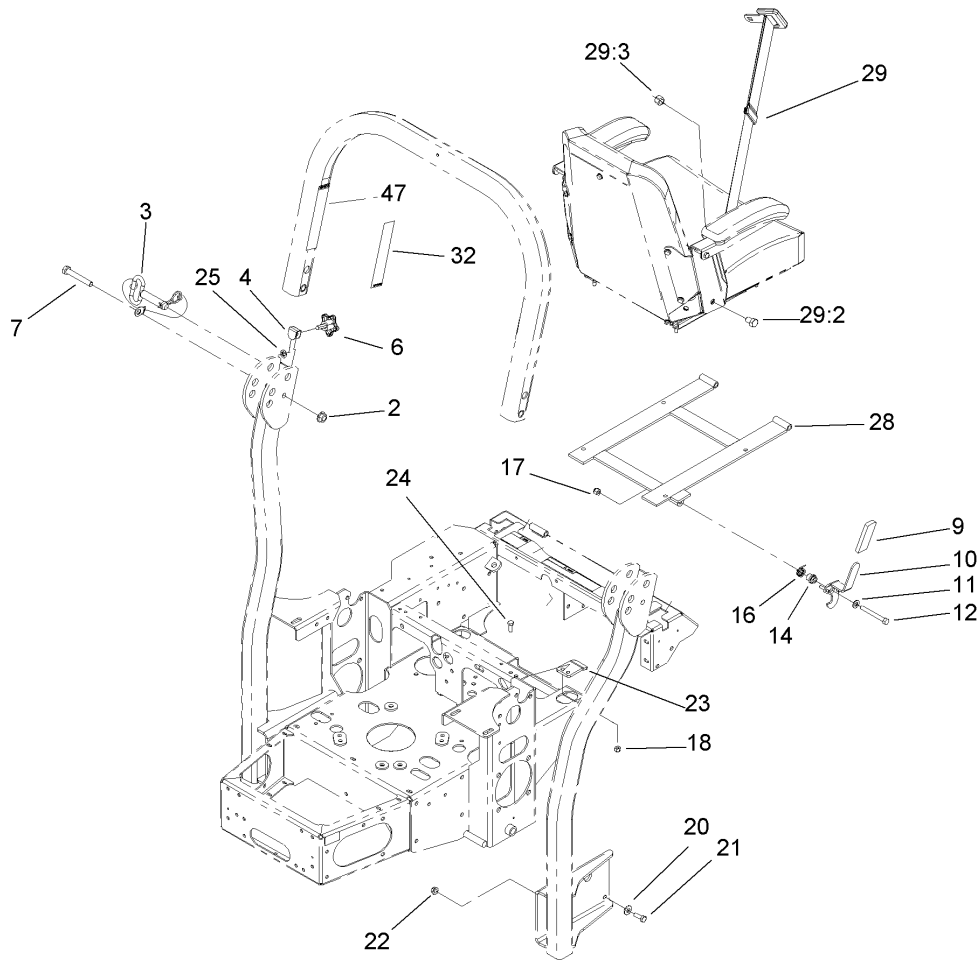

Roll-Over-Protection-System Assembly No. 107-8093

Ref	Part No.	Qty.	Description
2	32128-23	2	Nut-HF
3	103-4553	2	ROPS Fold Pin ASM
4	107-3124	2	Clip
6	106-0887	2	Knob
7	325-13	2	Screw-HH
9	62-9130	1	Grip-Handle
10	107-3083	1	Latch ASM
11	3256-24	1	Washer-Flat
12	323-20	1	Screw-HH
14	107-0075	1	Bushing-Latch, Seat
16	107-0076	1	Spring-Torsion
17	3296-39	1	Nut-Lock, NI
18	3296-29	2	Nut-Lock, NI
20	98-5975	8	Washer-Belleville
21	323-6	8	Screw-HH
22	3290-357	8	Nut-HHF
23	107-3059	1	Catch-Latch, Seat
24	322-4	2	Screw-HH
25	107-3154	2	Nut-Push
28	107-3052-03	1	Seat Support Frame ASM
29	103-4469	1	Seatbelt Kit
29:2	3212-4	2	Screw-HH
29:3	3296-38	2	Nut-Lock, NI
32	107-3069	1	Decal-Warning, Folding ROPS

Ref	Part No.	Qty.	Description
47	107-2102	1	Decal-Warning, Folding ROPS

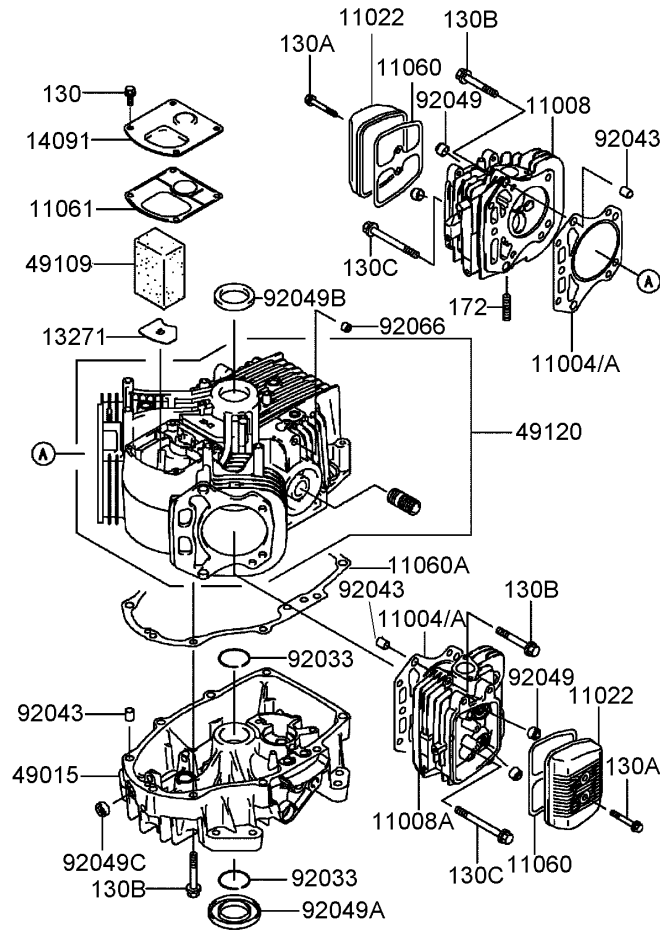

Cylinder and Crankcase Assembly Kawasaki FH580V-AS14

Ref	Part No.	Qty.	Description
①11004	11004-7010	1	Gasket-Head
①11004A	11004-7016	2	Gasket-Head
①11008	11008-6043	1	Head-Cylinder, No. 1
①11008A	11008-7020	1	Head-Cylinder, No. 2
①11022	11022-7003	2	Case-Rocker
①11060	11060-7001	2	Gasket-Case, Rocker
①11060A	11060-7008	1	Gasket-Cover, Crankcase
①11061	11061-7001	1	Gasket-Breather
①13271	13271-7016	1	Plate
①14091	14091-7006	1	Cover
①49015	49015-6253	1	Cover-Crankcase
①49109	49109-7002	1	Element-Breather
①49120	49120-7023	1	Crankcase
①92033	92033-7003	2	Ring-Snap
①92043	92043-7001	6	Pin
①92049	92049-7001	4	Seal-Oil, Rvc2 (6X11X10.2)
①92049A	92049-7015	1	Seal-Oil, Sd (35X62X8 L Hs)
①92049B	92049-7016	1	Seal-Oil, Sd (35X48X8 R Hs)
①92049C	92049-7019	1	Seal-Oil, So (8X14X5 Hs)
①92066	92066-7002	1	Plug
①130	130B0612	4	Bolt-Flanged
①130A	130B0640	4	Bolt-Flanged
①130B	130T0850	17	Bolt-Flanged
①130C	130T0875	2	Bolt-Flanged

Ref	Part No.	Qty.	Description
①172	172G0818	4	Bolt-Stud

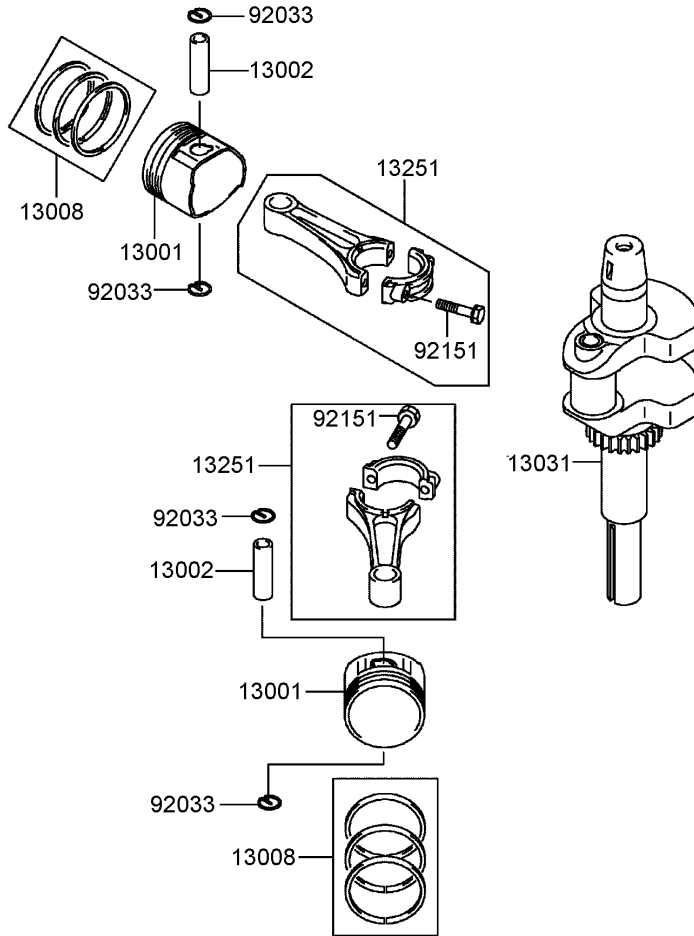

Piston/Crankshaft Assembly Kawasaki FH580V-AS14

Ref	Part No.	Qty.	Description				
⑤ 13001	13001-7010	2	Piston-Engine				
⑤ 13002	13002-7001	2	Pin-Piston				
⑤ 13008	13008-6060	2	Ring Set-Piston				
⑤ 13031	13031-7036	1	Crankshaft-Complete				
⑤ 13251	13251-7010	2	Connecting Rod ASM				
⑤ 92033	92033-7005	4	Ring-Snap				
⑤ 92151	92151-7017	4	Bolt (6X35)				

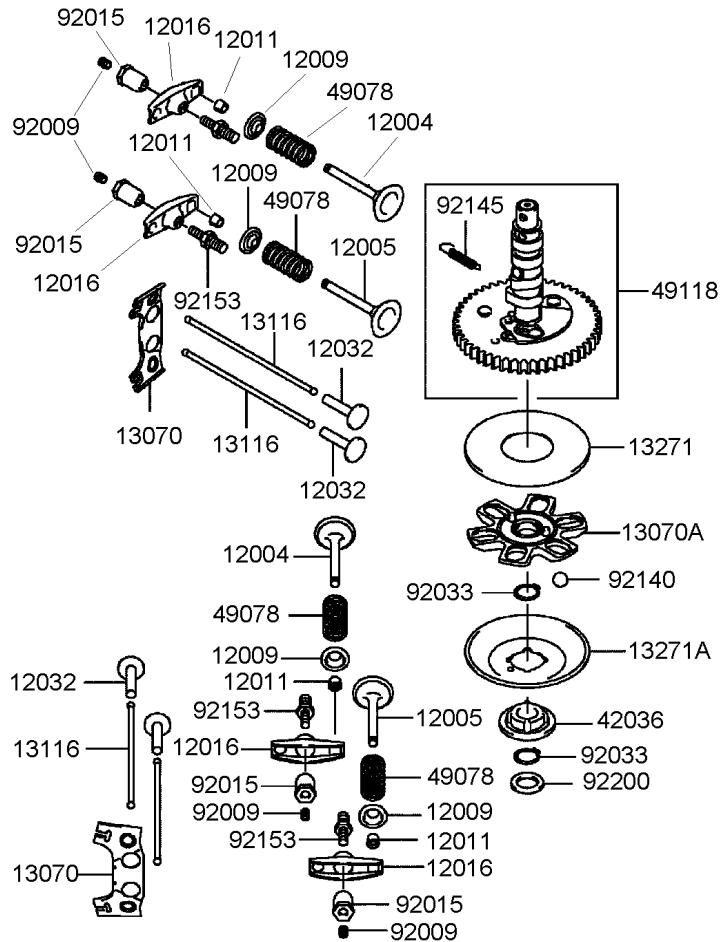

Valve and Camshaft Assembly Kawasaki FH580V-AS14

Ref	Part No.	Qty.	Description
③ 12004	12004-7003	2	Valve-Intake
③ 12005	12005-7003	2	Valve-Exhaust
③ 12009	12009-7001	4	Retainer-Spring, Valve
③ 12011	12011-2056	8	Collet
③ 12016	12016-7001	4	Arm-Rocker
③ 12032	12032-7001	4	Tappet
③ 13070	13070-7001	2	Guide
③ 13070A	13070-7004	1	Guide
③ 13116	13116-2057	4	Rod-Push
③ 13271	13271-7007	1	Plate
③ 13271A	13271-7021	1	Plate-Governor
③ 42036	42036-7009	1	Sleeve
③ 49078	49078-7001	4	Spring-Valve, Engine
③ 49118	49118-7004	1	Camshaft
③ 92009	92009-2341	4	Screw
③ 92015	92015-2253	4	Nut
③ 92033	92033-7001	2	Ring-Snap
③ 92140	92140-7002	6	Ball
③ 92145	92145-7001	1	Spring
③ 92153	92153-7019	4	Bolt
③ 92200	92200-7001	1	Washer

--	--	--	--

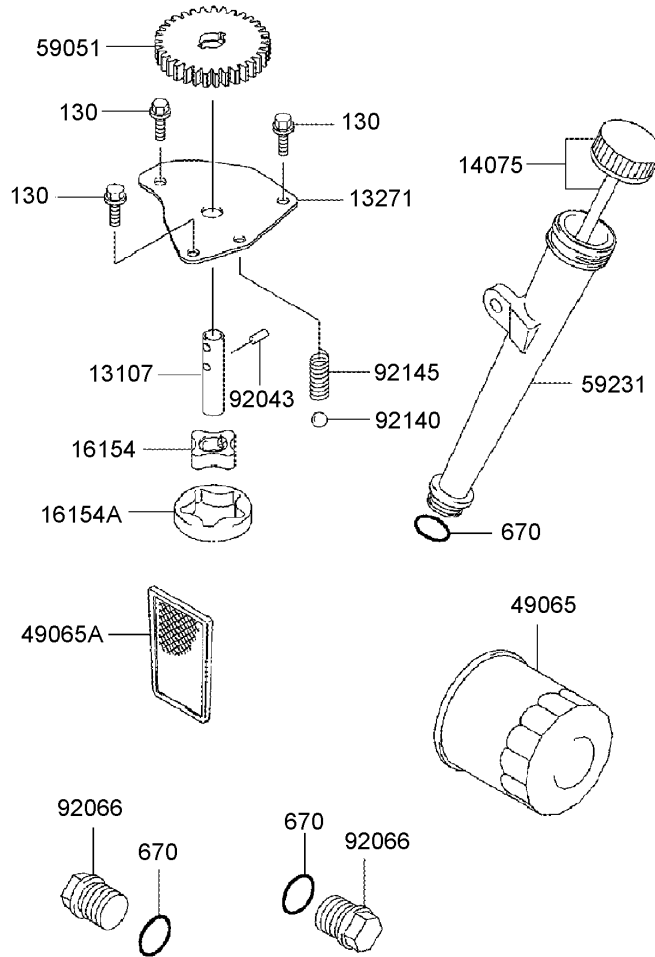

Lubrication Equipment Assembly Kawasaki FH580V-AS14

Ref	Part No.	Qty.	Description
⑤13107	13107-7009	1	Shaft
⑤13271	13271-7017	1	Plate
⑤14075	14075-7009	1	Cap ASM
⑤16154	16154-2053	1	Rotor-Pump (In)
⑤16154A	16154-2054	1	Rotor-Pump (Out)
⑤49065	49065-2078	1	Filter-Oil
⑤49065A	49065-7004	1	Filter-Oil
⑤59051	59051-7011	1	Gear-Spur
⑤59231	59231-7005	1	Filler
⑤92043	92043-7003	2	Pin
⑤92066	92066-7003	2	Plug
⑤92140	92140-7003	1	Ball
⑤92145	92145-7002	1	Spring
⑤130	130B0612	3	Bolt-Flanged
⑤670	670D2016	3	O-Ring (16Mm)

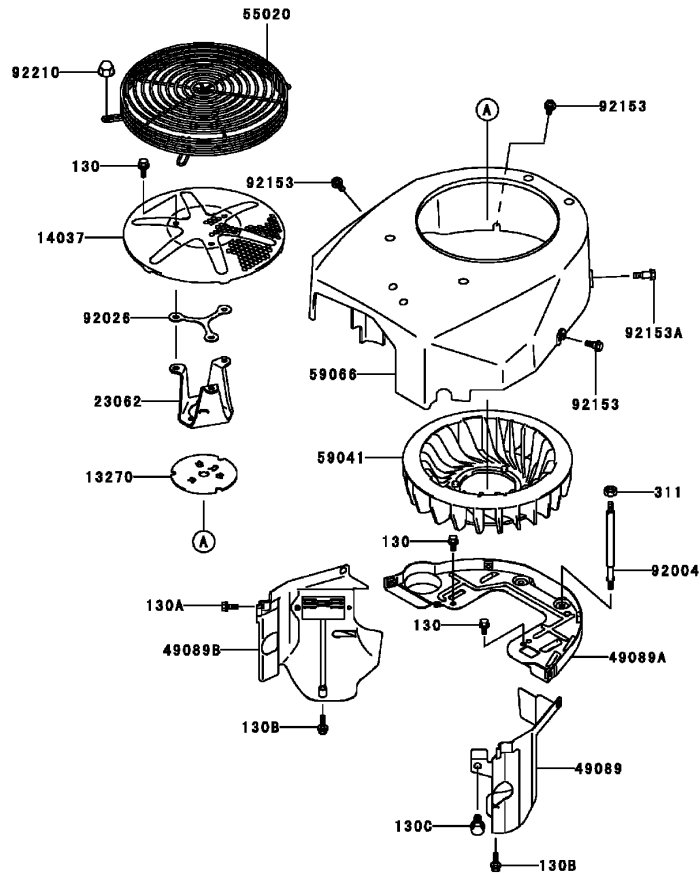

Cooling Equipment Assembly Kawasaki FH580V-AS14

Ref	Part No.	Qty.	Description
⑤ 13270	13270-7007	1	Plate
⑤ 14037	14037-7020-9H	1	Screen
⑤ 23062	23062-7010	1	Bracket
⑤ 49089	49089-7002	1	Shroud-Engine
⑤ 49089A	49089-7032	1	Shroud-Engine
⑤ 49089B	49089-7034	1	Shroud-Engine
⑤ 55020	55020-7004	1	Guard
⑤ 59041	59041-7010	1	Fan
⑤ 59066	59066-7002	1	Housing-Fan
⑤ 92004	92004-7006	2	Stud
⑤ 92026	92026-7007	1	Spacer
⑤ 92153	92153-7007	3	Bolt
⑤ 92153A	92153-7008	1	Bolt
⑤ 92210	92210-0003	4	Nut
⑤ 130	130B0612	5	Bolt-Flanged
⑤ 130A	130B0616	2	Bolt-Flanged
⑤ 130B	130B0625	2	Bolt-Flanged
⑤ 130C	130B0816	1	Bolt-Flanged
⑤ 311	311B0600	2	Nut-Hex

--	--	--	--

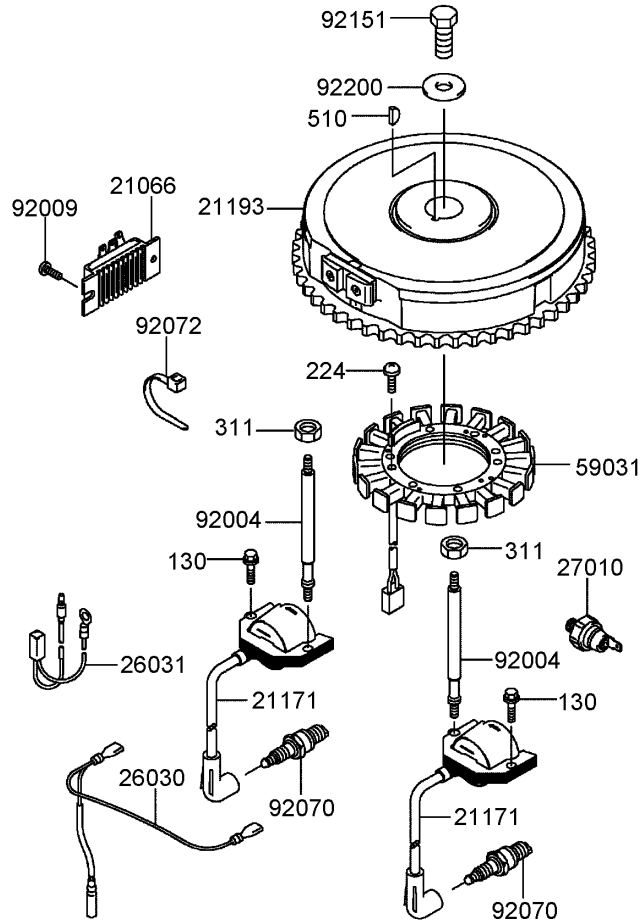

Electrical Equipment Assembly Kawasaki FH580V-AS14

Ref	Part No.	Qty.	Description
③21066	21066-7011	1	Regulator-Voltage
③21171	21171-7013	2	Ignition Coil ASM
③21193	21193-7007	1	Flywheel ASM
③26030	26030-7001	1	Harness
③26031	26031-7002	1	Harness
③27010	27010-7001	1	Switch
③59031	59031-7001	1	Coil-Charging
③92004	92004-7009	2	Stud
③92009	92009-2308	1	Screw
③92070	92070-7003	2	Plug-Spark (Rcj8Y, Solid)
③92072	92072-7003	2	Band
③92151	92151-2097	1	Bolt (12X30)
③92200	92200-7002	1	Washer
③130	130B0620	2	Bolt-Flanged
③224	224B0520	4	Screw-Pan
③311	311B0600	2	Nut-Hex
③510	510A5100	1	Key-Woodruff

--	--	--	--

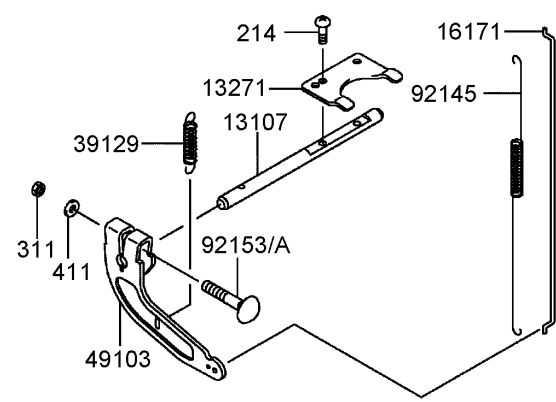
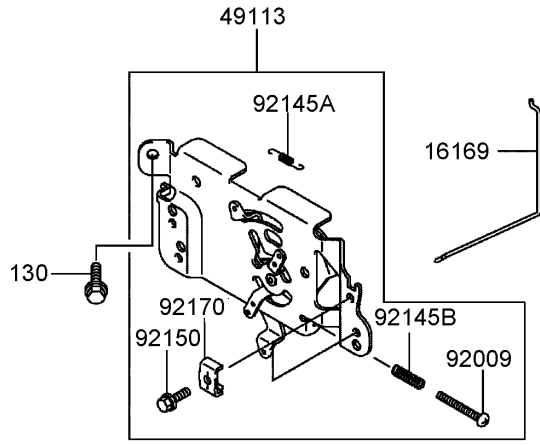

Control Equipment Assembly Kawasaki FH580V-AS14

Ref	Part No.	Qty.	Description				
③13107	13107-7010	1	Shaft				
③13271	13271-7018	1	Plate				
③16169	16169-7010	1	Link-Choke				
③16171	16171-7001	1	Link				
③39129	39129-7003	1	Spring-Governor				
③49103	49103-7004	1	Arm-Governor				
③49113	49113-7011	1	Panel-Control				
③92009	92009-7007	1	Screw (4X35)				
③92145	92145-7003	1	Spring				
③92145A	92145-7004	1	Spring				
③92145B	92145-7005	1	Spring				
③92150	92150-2182	2	Bolt (5X18)				
③92153	92153-7005	1	Bolt (6X35)				
③92153A	92153-7033	1	Bolt (6X35)				
③92170	92170-7001	2	Clamp				
③130	130B0612	2	Bolt-Flanged				
③214	214B0408	2	Screw-Pan				
③311	311B0600	1	Nut-Hex				
③411	411b0600	1	Washer-Plain				

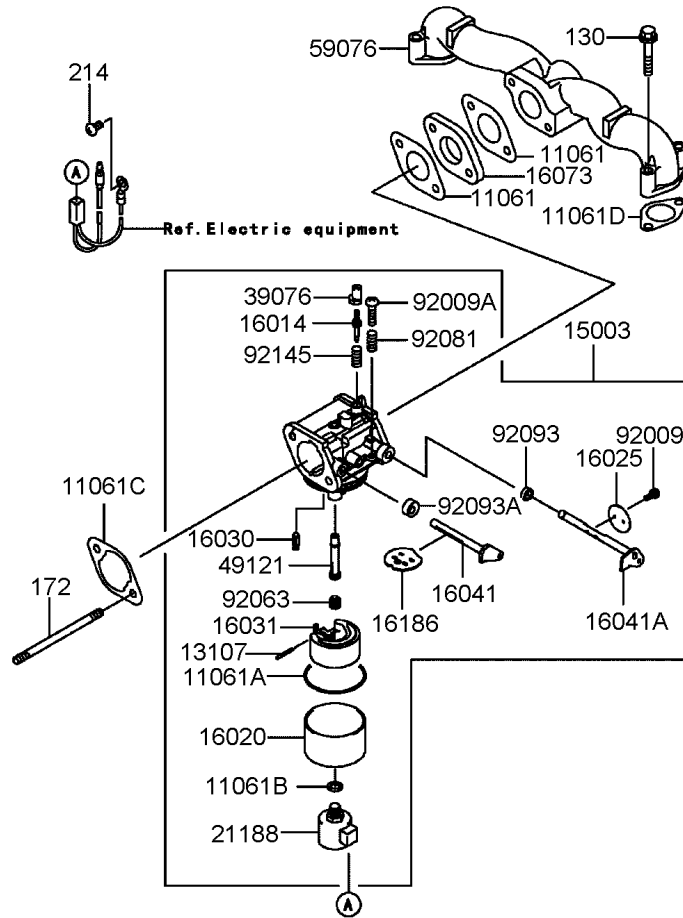

Carburetor Assembly Kawasaki FH580V-AS14

Ref	Part No.	Qty.	Description
● 11061	11061-7004	2	Gasket-Insulator
● 11061A	11061-7009	1	Gasket-Chamber
● 11061B	11061-7010	1	Gasket-Screw
● 11061C	11061-7018	1	Gasket-Cleaner, Air
● 11061D	11061-7019	2	Gasket
● 13107	13107-7018	1	Shaft
● 15003	15003-7081	1	Carburetor ASM
● 16014	16014-7004	1	Screw-Air, Pilot
● 16020	16020-7003	1	Chamber-Float
● 16025	16025-7006	1	Valve-Throttle
● 16030	16030-7003	1	Valve-Float
● 16031	16031-7002	1	Float
● 16041	16041-7016	1	Shaft-Choke, Carburetor
● 16041A	16041-7018	1	Shaft-Throttle, Carburetor
● 16073	16073-7007	1	Insulator
● 16186	16186-7004	1	Choke Valve ASM
● 21188	21188-7002	1	Solenoid
● 39076	39076-7001	1	Limiter
● 49121	49121-7004	1	Nozzle-Main
● 59076	59076-7001	1	Manifold-Intake
● 92009	92009-2083	2	Screw
● 92009A	92009-2349	1	Screw
● 92063	92063-7037	1	Jet-Main (No. 105)
● 92081	92081-2234	1	Spring

Ref	Part No.	Qty.	Description
● 92093	92093-2100	1	Seal
● 92093A	92093-7003	1	Seal
● 92145	92145-7015	1	Spring
● 130	130B0635	4	Bolt-Flanged
● 172	172G0685	2	Bolt-Stud
● 214	214B0510	1	Screw-Pan

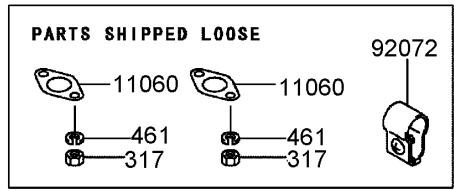
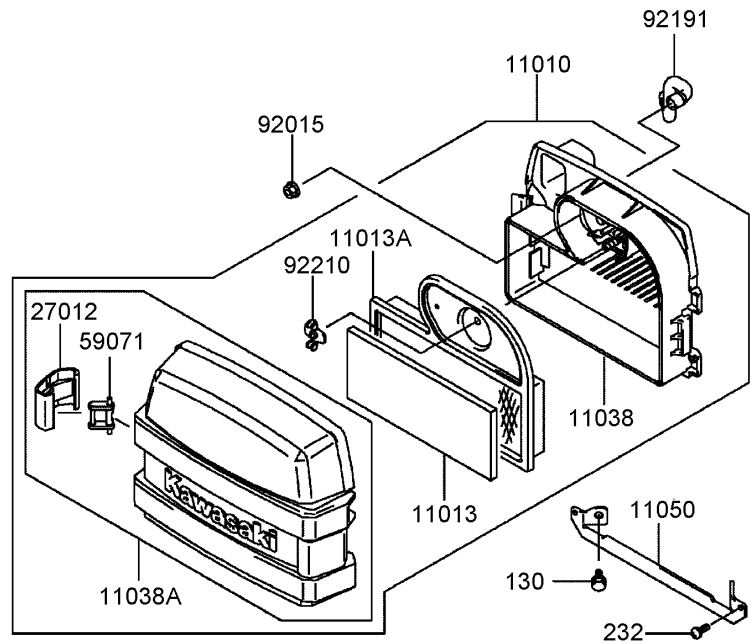

Air Filter and Muffler Assembly Kawasaki FH580V-AS14

Ref	Part No.	Qty.	Description
①	11010	1	Air Filter ASM
①	11013	1	Element-Filter, Air
①	11013A	1	Element-Filter, Air
①	11038	1	Air Filter Case ASM
①	11038A	1	Air Filter Case ASM
①	11050	1	Bracket
①	11060	2	Gasket-Muffler
①	27012	2	Hook-Filter, Air
①	59071	2	Joint
①	92015	2	Nut
①	92072	1	Band
①	92191	1	Tube
①	92210	1	Nut
①	130	2	Bolt-Flanged
①	232	2	Screw-Pan
①	317	4	Nut-Hex
①	461	4	Washer-Spring

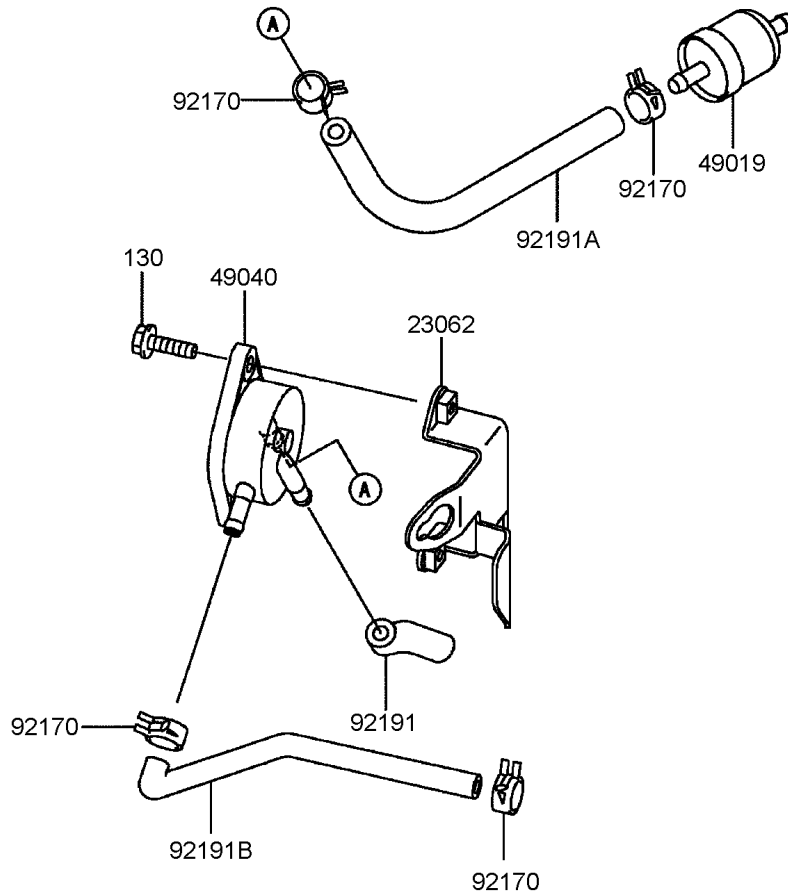

Fuel Tank and Valve Assembly Kawasaki FH580V-AS14

Ref	Part No.	Qty.	Description
②	23062-7004-9H	1	Bracket
②	49019-7001	1	Filter-Fuel
②	49040-7001	1	Pump-Fuel
②	92170-2088	4	Clamp
②	92191-7002	1	Tube
②	92191A-7003	1	Tube (6.35X12.7X160)
②	92191B-7004	1	Tube
②	130B0620	2	Bolt-Flanged

56033

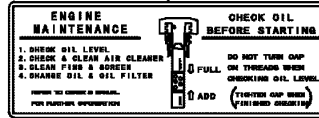

56070



56080



Decal Assembly Kawasaki FH580V-AS14

Ref	Part No.	Qty.	Description				
⑤56033	56033-7002	1	Label-Manual				
⑤56070	56070-7001	1	Label-Warning				
⑤56080	56080-7020	1	Label-Brand				

Attachments and Accessories

For 74410 - Z400 Z Master, With 52in 7-Gauge Side Discharge Mower

Product Name	Model/Part
Blade-Recycler	105-7779-03
Blade-Med Flow	105-7794-03
Blade-Low Flow	105-7795-03
Blade-Atomic	105-7796-03
Striping Kit	106-3370
Deck Lift Assist Kit	106-9749
Deluxe Suspension Seat	107-1891
Suspension Kit for Standard Seat	107-1892
Z Stand Kit	107-8599
Hitch Kit	99-8924

NOTES

NOTES

NOTES

