



**Count on it.**

**Operator's Manual**

# Reelmaster® 6500-D and 6700-D Traction Unit

Model No. 03806—Serial No. 250000001 and Up

Model No. 03807—Serial No. 250000001 and Up

Model No. 03808—Serial No. 250000001 and Up



G000836

## Warning

### CALIFORNIA Proposition 65 Warning

Diesel engine exhaust and some of its constituents are known to the State of California to cause cancer, birth defects, and other reproductive harm.

**Important:** This engine is not equipped with a spark arrester muffler. It is a violation of California Public Resource Code Section 4442 to use or operate the engine on any forest-covered, brush-covered, or grass-covered land. Other states or federal areas may have similar laws.

## Contents

Introduction .....	3	Recommended Maintenance	
Safety .....	4	Schedule(s) .....	29
Safe Operating Practices.....	4	Service Interval Chart .....	30
Toro Mower Safety.....	5	Daily Maintenance Checklist.....	31
Sound Pressure Level.....	6	Lubrication .....	31
Vibration Level.....	6	Greasing the Bearings and	
Safety and Instructional Decals .....	6	Bushings .....	31
Setup .....	12	Engine Maintenance .....	33
1 Checking Fluid Levels .....	12	Servicing the Air Cleaner.....	33
2 Installing the Cutting Units.....	12	Servicing the Engine Oil and Filter.....	35
3 Making Alternate Cutting Unit		Adjusting Throttle.....	35
Adjustments .....	14	Fuel System Maintenance .....	35
4 Adding Rear Ballast.....	14	Fuel Tank.....	35
5 Installing CE Decals.....	15	Fuel Lines and Connections.....	36
6 Reading the Manuals and Storing		Fuel Filter/Water Separator .....	36
Additional Parts .....	15	Replacing the Fuel Pre-Filter.....	36
Product Overview .....	16	Bleeding Air From Injectors .....	36
Controls .....	16	Electrical System Maintenance .....	37
Specifications .....	20	Battery Care .....	37
Operation .....	21	Fuses.....	38
Checking the Engine Oil .....	21	Optional Lighting.....	38
Checking the Cooling System.....	21	Drive System Maintenance .....	39
Filling the Fuel Tank.....	22	Checking the Torque of the Wheel Nuts	
Checking the Hydraulic Fluid.....	23	or Bolts .....	39
Checking the Tire Pressure .....	23	Checking the Planetary Gear Drive	
Checking the Reel to Bedknife		Oil.....	39
Contact.....	24	Changing the Planetary Gear Drive	
Starting and Stopping .....	24	Oil.....	39
Bleeding the Fuel System.....	24	Checking the Rear Axle Lubricant.....	40
Pushing or Towing the Machine.....	25	Changing the Rear Axle Lubricant.....	40
Checking the Interlock Switches.....	25	Rear Wheel Toe-In .....	41
Fault Memory and Retrieval.....	27	Adjusting the Traction Drive for	
Hydraulic Solenoid Valve		Neutral .....	41
Functions.....	27	Cooling System Maintenance .....	41
Operating Tips .....	28	Removing Debris .....	41
Maintenance .....	29	Maintaining the Cooling System .....	42
		Brake Maintenance .....	42
		Adjusting the Service Brakes .....	42
		Belt Maintenance .....	42
		Checking the Alternator Belt.....	42
		Hydraulic System Maintenance .....	43
		Changing the Hydraulic Fluid.....	43
		Replacing the Hydraulic Filter .....	43
		Checking the Hydraulic Lines and	
		Hoses .....	44
		Hydraulic System Test Ports.....	44
		Cutting Unit Maintenance.....	45
		Backlapping .....	45
		Adjust Turf Compensation Spring .....	46
		Adjusting the Cutting Unit Lowering	
		Rate .....	47
		Lifted Height of Outer Front Cutting	
		Units (Enable Position) .....	48
		Adjusting the Travel of the Front Three	
		Cutting Units .....	48
		Storage .....	50

Traction Unit.....	50
Engine.....	50
Schematics .....	51

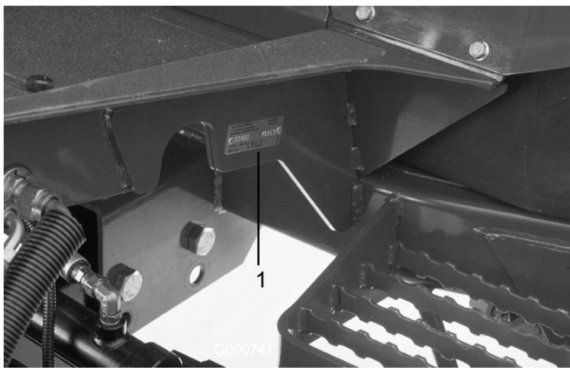
This manual uses two other words to highlight information. **Important** calls attention to special mechanical information and **Note** emphasizes general information worthy of special attention.

# Introduction

Read this information carefully to learn how to operate and maintain your product properly and to avoid injury and product damage. You are responsible for operating the product properly and safely.

You may contact Toro directly at [www.Toro.com](http://www.Toro.com) for product and accessory information, help finding a dealer, or to register your product.

Whenever you need service, genuine Toro parts, or additional information, contact an Authorized Service Dealer or Toro Customer Service and have the model and serial numbers of your product ready. Figure 1 identifies the location of the model and serial numbers on the product. Write the numbers in the space provided.



**Figure 1**

1. Location of the model and serial numbers

---

<b>Model No.</b> _____
<b>Serial No.</b> _____

This manual identifies potential hazards and has safety messages identified by the safety alert symbol (Figure 2), which signals a hazard that may cause serious injury or death if you do not follow the recommended precautions.




**Figure 2**

1. Safety alert symbol.
-

# Safety

This machine meets or exceeds CEN standard EN 836:1997, ISO standard 5395:1990, and ANSI B71.4-1999 specifications in effect at the time of production when, ballast is added; refer to **Adding Rear Ballast in Setup**, page 12.

**Note:** The addition of attachments made by other manufacturers that do not meet American National Standards Institute certification will cause noncompliance of this machine.

Improper use or maintenance by the operator or owner can result in injury. To reduce the potential for injury, comply with these safety instructions and always pay attention to the safety alert  symbol, which means CAUTION, WARNING, or DANGER-“personal safety instruction.” Failure to comply with the instruction may result in personal injury or death.

## Safe Operating Practices

The following instructions are from the CEN standard EN 836:1997, ISO standard 5395:1990, and ANSI B71.4-1999.

### Training

- Read the Operator’s Manual and other training material. If the operator(s) or mechanic(s) can not read English it is the owner’s responsibility to explain this material to them.
- Become familiar with the safe operation of the equipment, operator controls, and safety signs.
- All operators and mechanics should be trained. The owner is responsible for training the users.
- Never let children or untrained people operate or service the equipment. Local regulations may restrict the age of the operator.
- The owner/user can prevent and is responsible for accidents or injuries occurring to himself or herself, other people or property.

### Preparation

- Evaluate the terrain to determine what accessories and attachments are needed to properly and safely perform the job. Only use accessories and attachments approved by the manufacturer.
- Wear appropriate clothing including hard hat, safety glasses and ear protection. Long hair, loose clothing or jewelry may get tangled in moving parts.
- Inspect the area where the equipment is to be used and remove all objects such as rocks, toys and wire which can be thrown by the machine.

- Use extra care when handling diesel fuel. It is flammable and vapors are explosive.  
Use only an approved container.
- Never remove gas cap or add fuel with engine running. Allow engine to cool before refueling. Do not smoke.
- Never refuel or drain the machine indoors.
- Check that operator’s presence controls, safety switches and shields are attached and functioning properly. Do not operate unless they are functioning properly.

### Operation

- Never run an engine in an enclosed area.
- Only operate in good light, keeping away from holes and hidden hazards.
- Be sure all drives are in neutral and parking brake is engaged before starting engine. Only start engine from the operator’s position. Use seat belts if provided.
- Slow down and use extra care on hillsides. Be sure to travel in the recommended direction on hillsides. Turf conditions can affect the machine’s stability. Use caution while operating near drop-offs.
- Slow down and use caution when making turns and when changing directions on slopes.
- Never operate with guards not securely in place. Be sure all interlocks are attached, adjusted properly, and functioning property.
- Do not change the engine governor setting or overspeed the engine.
- Stop on level ground, raise the cutting units, disengage drives, engage parking brake (if provided), shut off engine before leaving the operator’s position for any reason including emptying the grass baskets.
- Stop equipment and inspect the machine after striking objects or if an abnormal vibration occurs. Make necessary repairs before resuming operations.
- Keep hands and feet away from the cutting units.
- Look behind and down before backing up to be sure of a clear path.
- Never carry passengers and keep pets and bystanders away.
- Slow down and use caution when making turns and crossing roads and sidewalks. Stop reels if not mowing.
- Do not operate the mower under the influence of alcohol or drugs.

- Use care when loading or unloading the machine into a trailer or truck.
- Use care when approaching blind corners, shrubs, trees, or other objects that may obscure vision.

## Maintenance and Storage

- Disengage drives, raise the cutting units, set parking brake, stop engine and remove key. Wait for all movement to stop before adjusting, cleaning or repairing.
- Clean grass and debris from cutting units, drives, mufflers, and engine to help prevent fires. Clean up oil or fuel spillage.
- Let engine cool before storing and do not store near flame.
- Shut off fuel while storing or transporting. Do not store fuel near flames or drain indoors.
- Park machine on level ground. Never allow untrained personnel to service machine.
- Use jack stands to support components when required.
- Carefully release pressure from components with stored energy.
- Disconnect battery and remove spark plug wire before making any repairs. Disconnect the negative terminal first and the positive last. Reconnect positive first and negative last.
- Use care when checking the reels. Wear gloves and use caution when servicing them.
- Keep hands and feet away from moving parts. If possible, do not make adjustments with the engine running.
- Charge batteries in an open well ventilated area, away from spark and flames. Unplug charger before connecting or disconnecting from battery. Wear protective clothing and use insulated tools.
- Keep all parts in good working condition and all hardware and hydraulic fittings tightened. Replace all worn or damaged decals.

## Toro Mower Safety

The following list contains safety information specific to Toro products or other safety information that you must know that is not included in the ANSI standards.

This product is capable of amputating hands and feet and throwing objects. Always follow all safety instructions to avoid serious injury or death.

Use of this product for purposes other than its intended use could prove dangerous to user and bystanders.

## Operation

- Sit on the seat when starting and operating the machine.
- Always wear substantial shoes. Do not operate the machine while wearing sandals, tennis shoes, or sneakers.
- Wearing safety shoes and long pants is advisable and required by some local ordinances and insurance regulations.
- Handle fuel carefully. Wipe up any spills.
- Check the safety interlock switches daily for proper operation. If a switch should fail, replace the switch before operating the machine. After every two years, replace all three interlock switches in the safety system, regardless if they are working properly or not.
- Using the machine demands attention. To prevent loss of control:  
Do not drive close to sand traps, ditches, creeks, or other hazards.
- Reduce speed when making sharp turns. Avoid sudden stops and starts.
- Do not touch the engine, muffler, or exhaust pipe while the engine is running or soon after it has stopped because these areas could be hot enough to cause burns.
- If a cutting unit strikes a solid object or vibrates abnormally, stop immediately, turn the engine off, wait for all motion to stop, and inspect the machine for damage. A damaged reel or bedknife must be repaired or replaced before operation is continued.
- Traverse slopes carefully. Do not start or stop suddenly when traveling uphill or downhill.
- The operator must be skilled and trained in how to drive on hillsides. Failure to use caution on slopes or hills may cause loss of control and cause the vehicle to tip or roll, possibly resulting in personal injury or death. On 4 wheel drive models, always use the seat belt and Roll Over Protection System (ROPS) together.
- If the engine stalls or loses headway and cannot make it to the top of a slope, do not turn the machine around. Always back slowly, straight down the slope.
- When a person or pet appears unexpectedly in or near the mowing area, stop mowing. Careless operation, combined with terrain angles, ricochets, or improperly positioned guards can lead to thrown object injuries. Do not resume mowing until the area is cleared.
- Do not park on slopes unless the wheels are chocked or blocked.

## Maintenance and Storage

- Make sure all hydraulic line connectors are tight and all hydraulic hoses and lines are in good condition before applying pressure to the system.
- Keep your body and hands away from pin hole leaks or nozzles that eject hydraulic fluid under high pressure. Use paper or cardboard, not your hands, to search for leaks. Hydraulic fluid escaping under pressure can have sufficient force to penetrate the skin and cause serious injury.
- Before disconnecting or performing any work on the hydraulic system, all pressure in the system must be relieved by stopping the engine and lowering the cutting units and attachments to the ground.
- If the engine must be running to perform a maintenance adjustment, keep hands, feet, clothing, and any parts of the body away from the cutting units, attachments and any moving parts. Keep everyone away.
- The engine must be shut off before checking the oil or adding oil to the crankcase.
- If major repairs are ever needed or if assistance is desired, contact an Authorized Toro Distributor.
- To make sure of optimum performance and continued safety certification of the machine,

use only genuine Toro replacement parts and accessories. Replacement parts and accessories made by other manufacturers could be dangerous, and such use could void the product warranty.

## Sound Pressure Level

This unit has an equivalent continuous A-weighted sound pressure at the operator ear of: 86 dB(A), based on measurements of identical machines per Directive 98/37/EC and amendments.

## Vibration Level

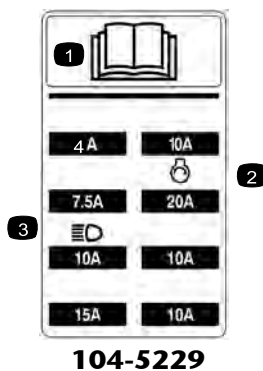
This unit does not exceed a vibration level of 2.5 m/s<sup>2</sup> at the hands based on measurements of identical machines per ISO 5349 procedures.

This unit does not exceed a vibration level of .5 m/s<sup>2</sup> at the posterior based on measurements of identical machines per ISO 2631 procedures.

## Safety and Instructional Decals

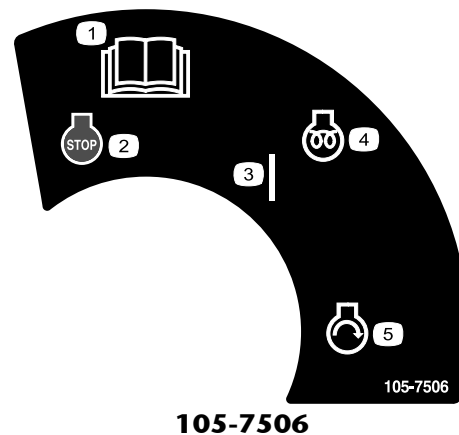


Safety decals and instructions are easily visible to the operator and are located near any area of potential danger. Replace any decal that is damaged or lost.



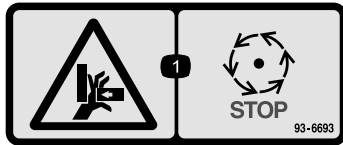
**104-5229**

1. Read the *Operator's Manual*.
2. Fuse for starter
3. Fuse for headlights (optional)



**105-7506**

1. Read the *Operator's Manual*.
2. Engine—stop
3. On
4. Engine—preheat
5. Engine—start



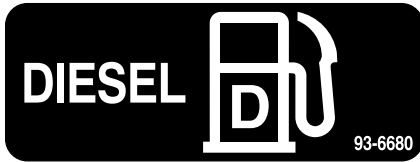
**93-6693**

1. Crushing hazard of hand—wait for moving parts to stop.



**93-6696**

1. Stored energy hazard—read the *Operator's Manual*.

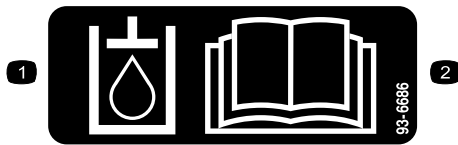


**93-6680**



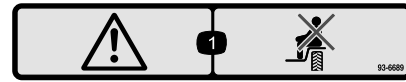
**93-6687**

1. Do not step here.



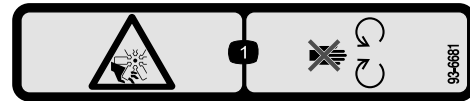
**93-6686**

1. Hydraulic oil
2. Read the *Operator's Manual*.



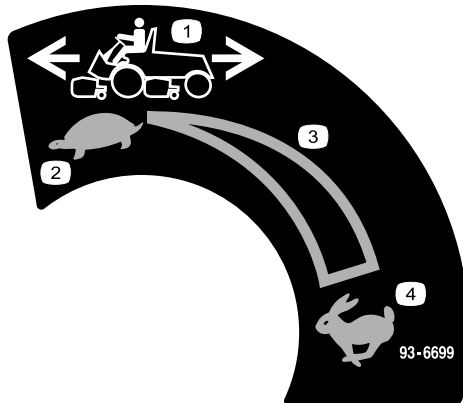
**93-6689**

1. Warning—do not carry passengers.



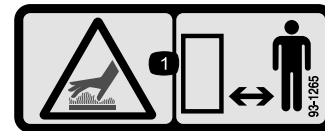
**93-6681**

1. Warning—do not carry passengers.



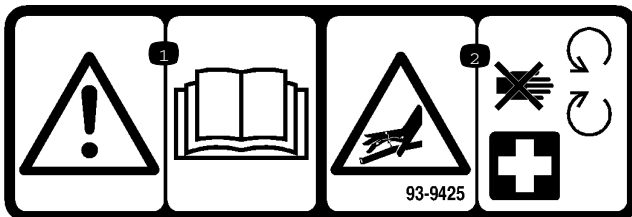
**93-6699**

- |                  |                                |
|------------------|--------------------------------|
| 1. Machine speed | 3. Continuous variable setting |
| 2. Slow          | 4. Fast                        |



**93-1265**

1. Hot surface/burn hazard—stay a safe distance from the hot surface.



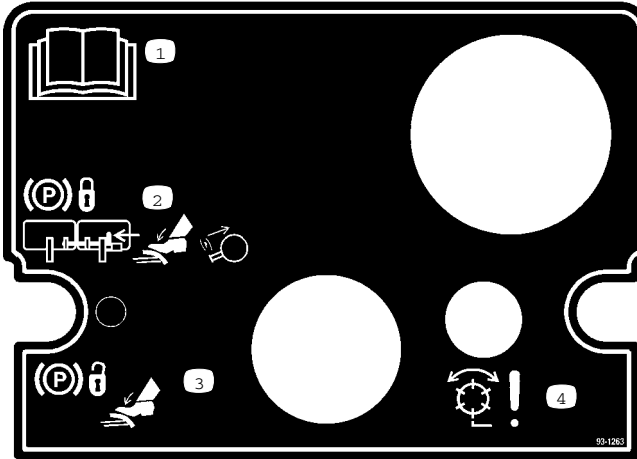
**93-9425**

1. Read the *Operator's Manual*.
2. Hydraulic hoses are under pressure—stay away from moving parts.



**104-9298**

1. Read the *Operator's Manual*.



**93-1263**

1. Read the *Operator's Manual*.
2. To engage the parking brake, connect the brake pedals with the locking pin, push down on both pedals, and pull the brake latch out.
3. To release the parking brake, press both pedals until the parking brake latch retracts.
4. Danger—reels enabled.

**REELMASTERS  
6500-D / 6700-D  
QUICK REFERENCE AID**

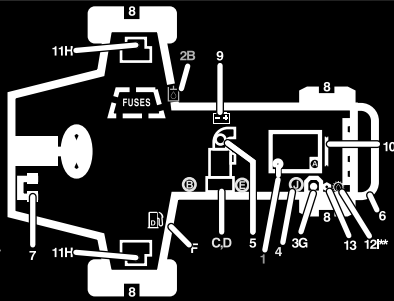


**CHECK/SERVICE (daily)**

1. OIL LEVEL, ENGINE
2. OIL LEVEL, HYDRAULIC TANK
3. COOLANT LEVEL, RADIATOR
4. FUEL /WATER SEPARATOR
5. AIR FILTER SERVICE INDICATOR
6. RADIATOR SCREEN
7. BRAKE FUNCTION
8. TIRE PRESSURE (15-20 PSI)

**CHECK/SERVICE  
SEE OPERATOR'S MANUAL**

9. BATTERY
10. BELTS (FAN, ALT.)
11. PLANETARY GEAR DRIVE
12. REAR AXLE OIL FILL\*\*
13. REAR AXLE OIL CHECK (2)\*\*



**FLUID SPECIFICATIONS/CHANGE INTERVALS**

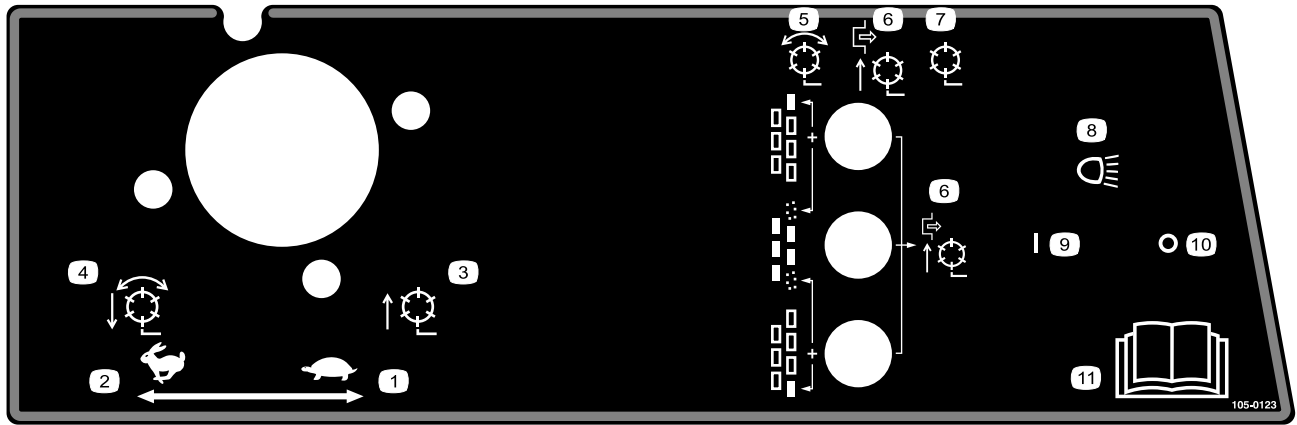
SEE OPERATOR'S MANUAL FOR INITIAL CHANGES.	FLUID TYPE	CAPACITY	CHANGE INTERVAL		FILTER PART NO.
			FLUID	FILTER	
A. ENGINE OIL	SAE 10W-30CD	7.5 QTS.	100 HRS.	100 HRS.	99-8384
B. HYD. CIRCUIT OIL	MOBIL DTE15M	9 GALS.*	800 HRS.	SEE SERVICE INDICATOR	94-2621
C. PRIMARY AIR FILTER	---	---	---	SEE SERVICE INDICATOR	93-9162
D. SAFETY AIR FILTER	---	---	---	SEE OPERATOR'S MANUAL	93-9163
E. FILTER, IN-LINE FUEL	---	---	---	400 HRS.	99-8358
F. FUEL TANK	NO, 2-Diesel	15 GALS.	Drain and flush, 2 yrs.		
G. COOLANT	50/50 ETHYLENE GLYCOL/WATER	2.5 GALS.	Drain and flush, 2 yrs.		
H. PLANETARY GEAR DRIVE	SAE85W-140	16 OZ.	800 HRS.	---	---
I. REAR AXLE OIL**	SAE85W-140	80 OZ.	800 HRS.	---	---
J. WATER SEPARATOR				400 HRS	98-9764

\* INCLUDES FILTER, CHECK DIP STICK, DO NOT OVER FILL.

\*\*4WD ONLY

105-0134

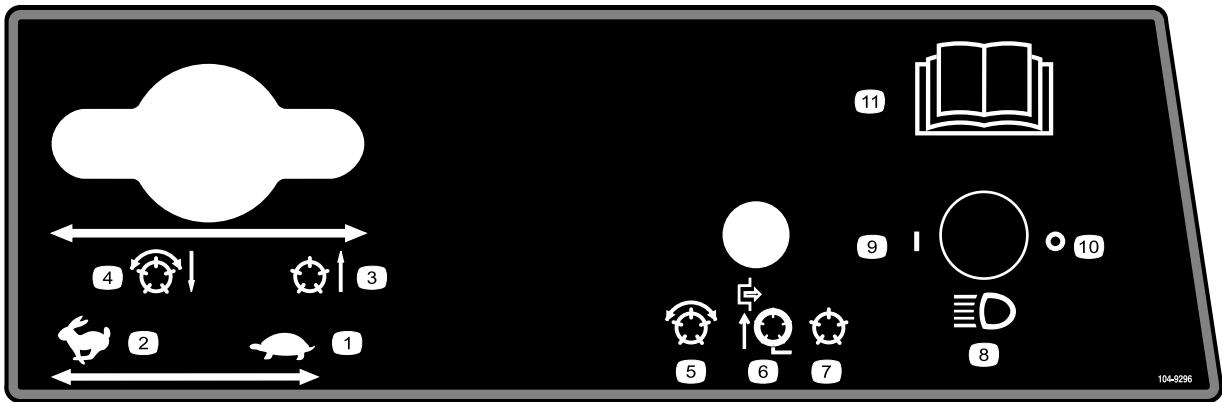
**105-0134**



**105-0123**

Model 03807

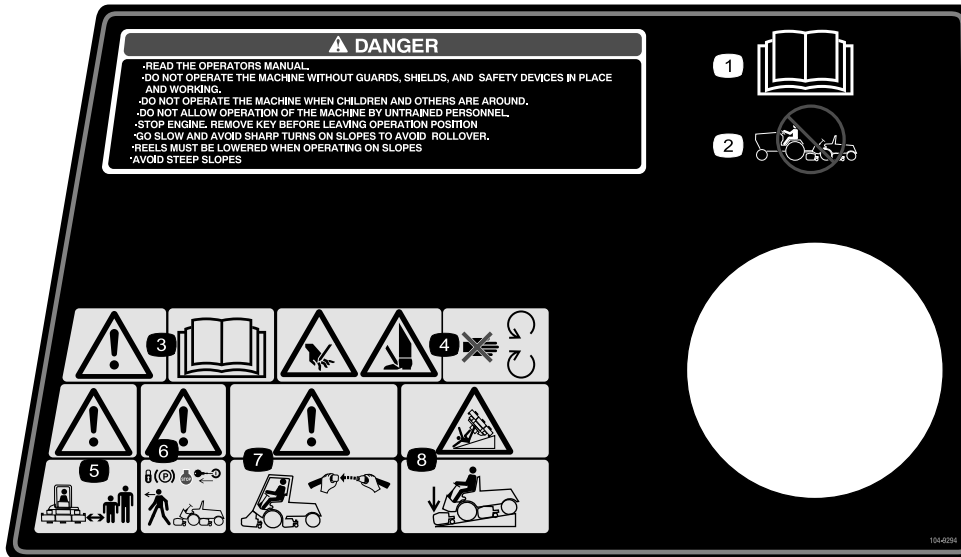
- |  |  |
|--|--|
| 1. Throttle—slow   | 7. Reels disabled—lift and lower       |
| 2. Throttle—fast   | 8. Headlights (optional)               |
| 3. Reels raised and off                                  | 9. Headlights—On                       |
| 4. Reels lowered and on when enabled—forward and backlap | 10. Headlights—Off                     |
| 5. Reels—enabled   | 11. Read the <i>Operators Manual</i> . |
| 6. Reels disabled—lift only                              |  |



**104-9296**

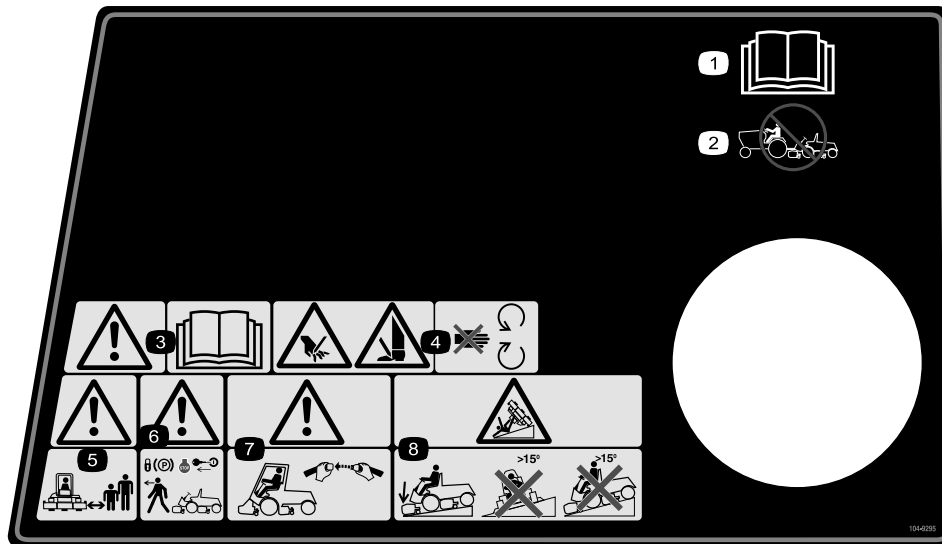
Models 03806 and 03807

- |                         |  |                                  |   |
|-------------------------|--|----------------------------------|---|
| 1. Throttle—slow        | 4. Reels lowered and on when enabled—forward and backlap | 7. Reels disabled—lift and lower | 10. Headlights—Off  |
| 2. Throttle—fast        | 5. Reels enabled   | 8. Headlights (optional)         | 11. Read the <i>Operator's Manual</i> for further instructions. |
| 3. Reels raised and off | 6. Reels disabled—lift only                              | 9. Headlights—On                 |   |



**104-9294**

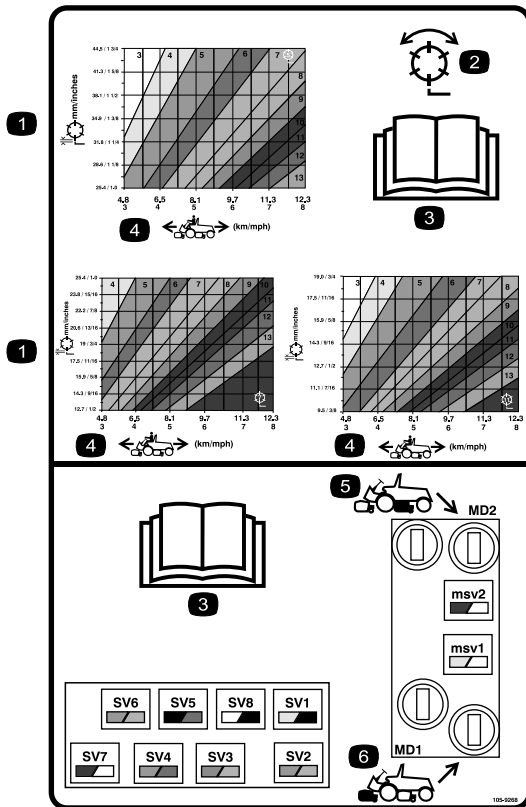
- |  |  |   |   |
|--|--|---|---|
| 1. Read the <i>Operator's Manual</i> . | 3. Warning—Read the <i>Operator's Manual</i> .                 | 5. Warning—keep bystanders a safe distance from the machine.  | 7. Warning—use a rollover protection system and wear the seat belt. |
| 2. Do not tow the machine.             | 4. Cutting hazard of hand or foot—stay away from moving parts. | 6. Warning—lock the parking brake, stop the engine, and remove the ignition key before leaving the machine. | 8. Tipping hazard—lower the cutting unit when driving down slopes.  |



**104-9295**

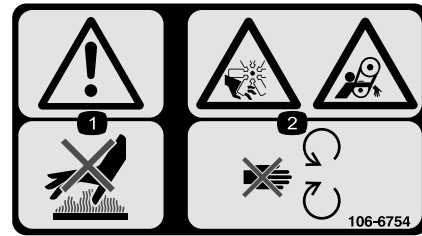
Replaces 104-9294 for CE

- |  |  |   |   |
|--|--|---|---|
| 1. Read the <i>Operator's Manual</i> . | 3. Warning—Read the <i>Operator's Manual</i> .                 | 5. Warning—keep bystanders a safe distance from the machine.  | 7. Warning—use a rollover protection system and wear the seat belt.   |
| 2. Do not tow the machine.             | 4. Cutting hazard of hand or foot—stay away from moving parts. | 6. Warning—lock the parking brake, stop the engine, and remove the ignition key before leaving the machine. | 8. Tipping hazard—lower the cutting unit when driving down slopes and do not drive across or down slopes greater than 15 degrees. |



**105-9268**

1. Reel—height of cut
2. Reel—mow and backlap
3. Read the *Operator's Manual*.
4. Machine speed
5. Rear reels circuit controls
6. Front reels circuit controls



**106-6754**

1. Warning—do not touch the hot surface.
2. Cutting/dismemberment hazard, fan and entanglement hazard, belt—stay away from moving parts.



**67-7960**



**Battery Symbols**

Some or all of these symbols are on your battery

1. Explosion hazard
2. No fire, open flame, or smoking.
3. Caustic liquid/chemical burn hazard
4. Wear eye protection
5. Read the *Operator's Manual*.
6. Keep bystanders a safe distance from the battery.
7. Wear eye protection; explosive gases can cause blindness and other injuries
8. Battery acid can cause blindness or severe burns.
9. Flush eyes immediately with water and get medical help fast.
10. Contains lead; do not discard.

# Setup

## Loose Parts

Use the chart below to verify that all parts have been shipped.

Step	Description	Qty.	Use
1	No parts required	–	Check fluid levels.
2	Large O-ring Counter weight Steering locking pin	14/10 7/5 7/5	Install the cutting units.
3	No parts required	–	Make cutting unit adjustments if needed.
4	Calcium chloride (obtain separately) Rear weight kit, part number 104–1478 (obtain separately)	100lb 1	Add rear ballast (if required).
5	CE decals CE certificate	4 2	Install the CE decals.
6	Operator's Manual Engine Operator's Manual Parts Catalog Diagnostic ACE display overlay Ignition keys on ring Hood lock key Gauge bar Screw Wing nut	1 1 1 1 1 1 1 2 2	Read the manuals and watch the video before operating the machine.

### Step 1

Refer to Checking the Hydraulic Oil in Operation, page 21.

- Rear axle lubricant

Refer to Checking the Rear Axle Lubricant in Drive System Maintenance, page 39.

## Checking Fluid Levels

### No Parts Required

#### Procedure

Before starting the engine for the first time, check the following fluid levels:

- Engine oil

Refer to Checking the Engine Oil in Operation, page 21.

- Engine coolant

Refer to Checking the Cooling System Operation, page 21.

- Hydraulic oil

# Step 2

## Installing the Cutting Units

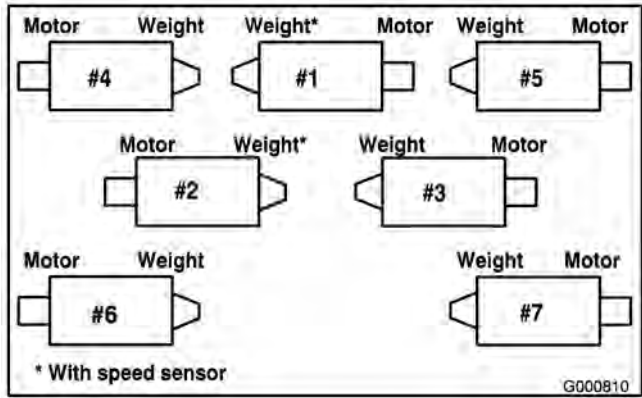
### Parts needed for this step:

14/10	Large O-ring
7/5	Counter weight
7/5	Steering locking pin

### Procedure

Cutting unit models 03860, 03861, and 03862 can be installed at any of the mounting locations on the traction unit. Figure 3 shows the orientation of the hydraulic drive motor for each of the locations. For any of the locations requiring the motor to be mounted on the right end of the cutting unit, install a counter weight on the left end of the cutting unit. For the locations requiring the motor to be mounted on the left end, install a counter weight on the right end of the cutting unit.

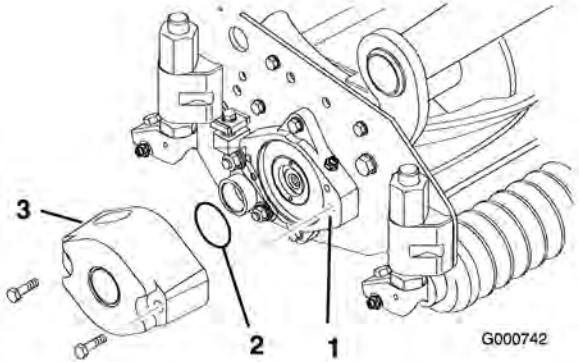
**Note:** Counterweight mounting capscrews are shipped installed on the right bearing housing of the cutting units. The capscrews on left bearing housing are to be used for securing the hydraulic motor.



**Figure 3**

1. Remove cutting units from cartons. Assemble and adjust per *Cutting Unit Operator's Manual*.
2. Remove protective plugs from each end of cutting unit.

3. Lubricate and install a large O-ring into bearing housing groove on each end of cutting unit (Figure 4 & Figure 7).

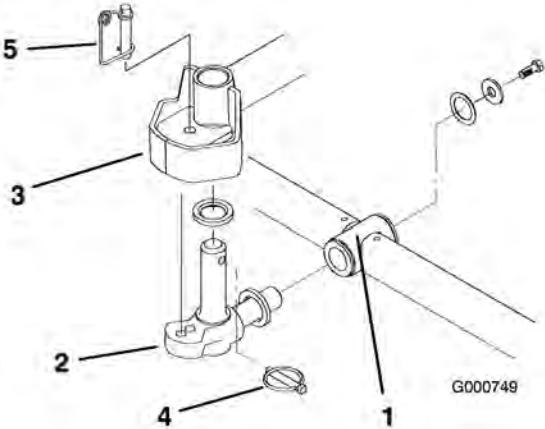


**Figure 4**

1. Bearing housing
2. Large o-ring
3. Counterweight

**Note:** Before installing cutting unit motors or counterweights, lubricate internal splines of cutting unit reel shafts with grease.

4. Install a counter weight onto appropriate end of each cutting unit with capscrews provided (Figure 4).
5. Thoroughly grease the cutting unit reel bearings prior to installation on the traction unit. Grease should be evident at the inboard reel seals; refer to *Cutting Unit Operator's Manual* for greasing procedure.
6. Insert a thrust washer onto horizontal shaft of pivot knuckle as shown in Figure 5.

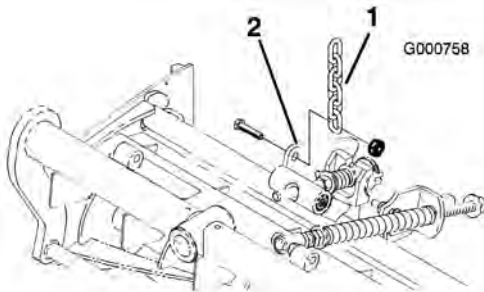


**Figure 5**

1. Carrier frame
2. Pivot knuckle
3. Lift arm steering plate
4. Lynch pin
5. Steering locking pin

7. Insert the horizontal shaft of the pivot knuckle into the mounting tube of the carrier frame (Figure 5).

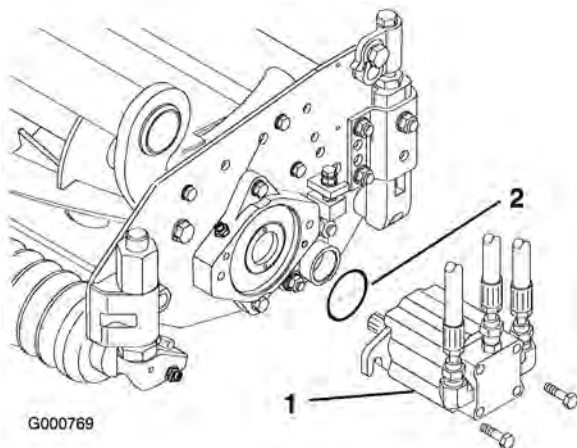
8. Secure pivot knuckle to carrier frame with a thrust washer, flat washer and a flange head capscrew (Figure 5).
9. Insert a thrust washer onto vertical shaft of pivot knuckle (Figure 5).
10. If removed, insert the vertical shaft of the pivot knuckle into lift arm pivot hub (Figure 5). Guide the pivot knuckle in place between the two rubber centering bumpers in the under side of the lift arm steering plate.
11. Insert the lynch pin into the cross hole on the pivot knuckle shaft (Figure 5).
12. Remove nut securing turf compensation spring mounting bracket to cutting unit stabilizer ear (Figure 6). Insert tipper chain onto capscrew and secure with nut removed.



**Figure 6**

1. Lift chain
2. Cutting unit stabilizer ear

13. Mount the motor to the drive end of the cutting unit and secure with two capscrews provided (Figure 7).



**Figure 7**

1. Motor
2. O-ring

**Note:** If fixed cutting unit position is required, insert steering locking pin into pivot knuckle mounting hole (Figure 5).

14. Hook spring wire around bottom of steering locking pin (Figure 5).

## Step

# 3

## Making Alternate Cutting Unit Adjustments

### No Parts Required

### Procedure

The factory sets the tractor appropriately for most fairway mowing applications. Several adjustments for fine-tuning the machine for particular applications are included in Cutting Unit Maintenance, page 45, as follows:

- Adjusting the turf compensation spring  
Adjusts the amount of fore and aft rotation available, the amount of ground clearance in transport, and transfers the weight from the front to rear roller, reducing bobbing (a wave pattern in the turf).
- Adjusting the cutting unit lowering rate  
Adjusts the speed at which the cutting units lower.
- Adjusting the lifted height of the outer front cutting units  
Adjusts the turnaround height of the outer front cutting units to provide greater clearance on contoured fairways.
- Adjusting the travel of the front three cutting units  
Adjusts the downward travel of the front three cutting units to allow for highly contoured fairways.

## Step **4**

### Adding Rear Ballast

#### Parts needed for this step:

100lb	Calcium chloride (obtain separately)
1	Rear weight kit, part number 104-1478 (obtain separately)

#### Procedure

To comply with CEN standard EN 836:1997, ISO standard 5395:1990, and the ANSI B71.4-1999 Standard, add 100 lb (45 kg) of calcium chloride ballast to the rear wheels and install the rear weight kit (Part Number 104-1478).

**Important:** If a puncture occurs in a tire with calcium chloride, remove unit from turf area as quickly as possible. To prevent possible damage to turf, immediately soak affected area with water.

## Step **5**

### Installing CE Decals

#### Parts needed for this step:

4	CE decals
2	CE certificate

#### Procedure

If you will be using the machine in a CE country, install the supplied CE decals over the corresponding ANSI decals on the product. Store the CE certificates in a safe location.

## Step **6**

### Reading the Manuals and Storing Additional Parts

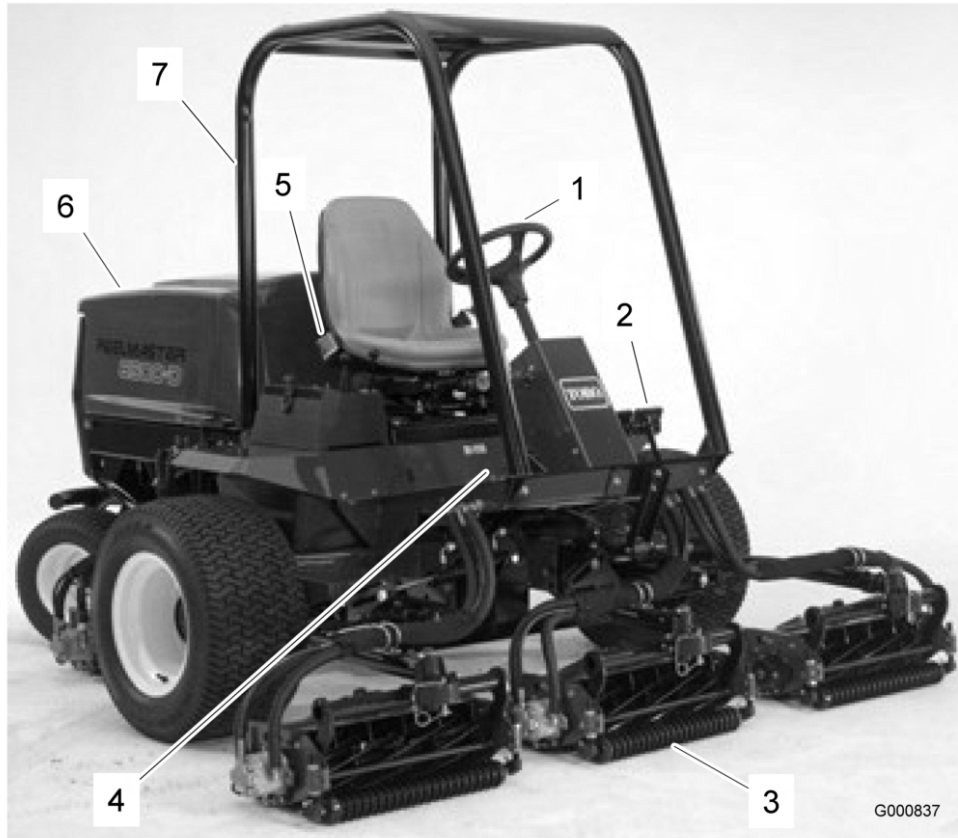
#### Parts needed for this step:

1	<i>Operator's Manual</i>
1	<i>Engine Operator's Manual</i>
1	<i>Parts Catalog</i>
1	Diagnostic ACE display overlay
1	Ignition keys on ring
1	Hood lock key
1	Gauge bar
2	Screw
2	Wing nut

#### Procedure

1. Read the manuals.
2. View the Operator video.
3. The diagnostic ACE display overlay is for diagnosing machine malfunctions. Store it in a safe location.
4. The gauge bar, screws, and wing nut are for use in setting the cutting units (refer to the cutting unit *Operator's Manual*). Store them in a safe location.

# Product Overview



**Figure 8**

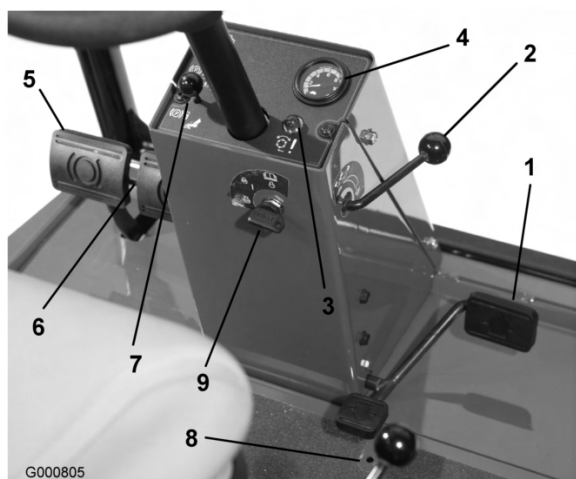
- |                   |                   |                |                                       |
|-------------------|-------------------|----------------|---------------------------------------|
| 1. Steering wheel | 3. Cutting unit   | 5. Manual tube | 7. Roll over protection system (ROPS) |
| 2. Brake pedals   | 4. Traction pedal | 6. Hood        |                                       |
- 

## Controls

### Traction Pedal

The traction pedal (Figure 9) controls forward and reverse operation. Depress top of pedal to move forward and bottom to move backward. Ground speed depends on how far pedal is depressed. For no load, maximum ground speed, fully depress pedal while throttle is in FAST.

To stop, reduce foot pressure on traction pedal and allow it to return to center position.



**Figure 9**

- |                          |                          |
|--------------------------|--------------------------|
| 1. Traction pedal        | 6. Parking brake latch   |
| 2. Forward speed limiter | 7. Locking pin           |
| 3. Red diagnostic light  | 8. Reverse speed limiter |
| 4. Speedometer           | 9. Key switch            |
| 5. Brake pedals          |                          |

---

## Forward Speed Limiter

Preset the forward speed limiter (Figure 9) to limit the amount the traction pedal can be depressed in the forward direction to maintain a constant mowing speed.

## Red Diagnostic Light

The red diagnostic light (Figure 9), located on steering tower, is used to convey several different messages. While starting the machine, the light will illuminate when the glow plugs are on.

If the light blinks during operation, it may indicate any of the following:

- The machine is being operated faster than the maximum speed value initially programmed into the ECU.
- An electrical malfunction has been detected (open or shorted output).
- A hydraulic leak has been detected (Only if Turfdefender leak detector is installed on machine)
- A communications error has been detected (Only if Turfdefender leak detector is installed on machine)

## Key Switch

The key switch (Figure 9) has three positions: OFF, ON/Preheat and START.

## Speedometer

The speedometer (Figure 9) indicates ground speed at which machine is traveling.

## Brake Pedals

Two brake pedals (Figure 9) operate individual wheel brakes for turning assistance, parking, and to aid in obtaining better sidehill traction. Locking pin connects the pedals for parking brake operation and transport.

## Parking Brake Latch

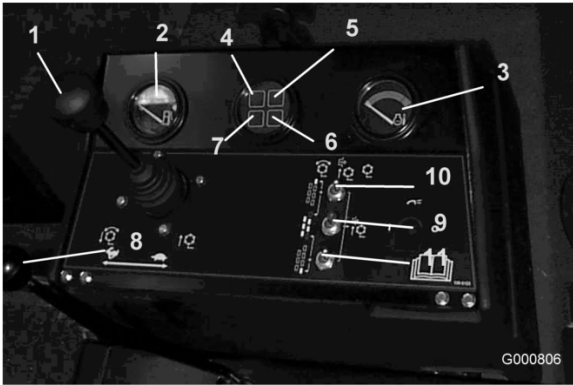
A knob on the left side of console actuates parking brake lock (Figure 9). To engage parking brake, connect pedals with locking pin, push down on both pedals and pull parking brake latch out. To release parking brake, depress both pedals until parking brake latch retracts.

## Reverse Speed Limiter

Adjust the screw (Figure 9) to limit the amount the traction pedal can be depressed in the rearward direction to limit speed.

## Lower Mow/Raise Control Lever (Joystick)

The lever (Figure 10 and Figure 11) raises and lowers the cutting units and also starts and stops the reels.



**Figure 10**  
Model 03808

- |   |   |
|---|---|
| 1. Lower mow/raise control lever            | 7. Charge indicator                       |
| 2. Fuel gauge                               | 8. Throttle control                       |
| 3. Engine coolant temperature gauge         | 9. Enable/disable switch (Master)         |
| 4. Engine oil pressure warning light        | 10. Enable/disable switch (#7) right rear |
| 5. Engine coolant temperature warning light | 11. Enable/disable switch (#6) left rear  |
| 6. Glow plug indicator light                |   |

## Fuel Gauge

The fuel gauge (Figure 10 and Figure 11) indicates level of fuel in tank.

## Engine Oil Pressure Warning Light

This light (Figure 10 and Figure 11) indicates dangerously low engine oil pressure.

## Throttle Control

Move the control (Figure 10 and Figure 11) forward to increase engine speed, rearward to decrease speed.

## Engine Coolant Temperature Warning Light

The light (Figure 10 and Figure 11) illuminates and the engine shuts down when the coolant reaches a dangerously high temperature.

## Glow Plug Indicator Light

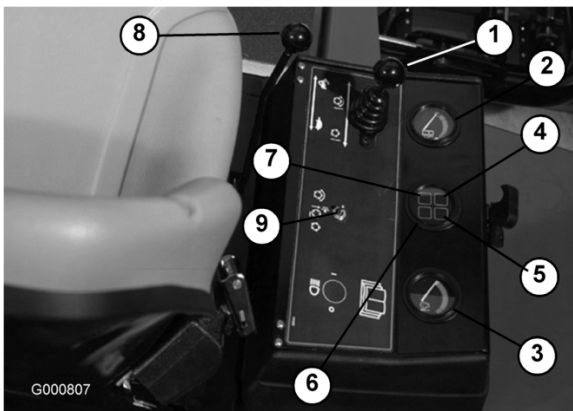
When the indicator light (Figure 10 and Figure 11) is lit, indicates glow plugs are on.

## Charge Indicator

The charge indicator (Figure 10 and Figure 11) illuminates when system charging circuit malfunctions.

## Enable/Disable Switches

The enable/disable switches (Figure 10 and Figure 11) are used in conjunction with the lower mow/raise control lever (Joystick) to operate reels. Reels can be raised but not lowered when in mid position.



**Figure 11**  
Models 03806 and 03807

- |   |                                   |
|---|-----------------------------------|
| 1. Lower mow/raise control lever            | 6. Glow plug indicator light      |
| 2. Fuel gauge                               | 7. Charge indicator               |
| 3. Engine coolant temperature gauge         | 8. Throttle control               |
| 4. Engine oil pressure warning light        | 9. Enable/disable switch (Master) |
| 5. Engine coolant temperature warning light |                                   |

## Hour Meter

The hour meter (Figure 12) shows total hours that machine has been operated.

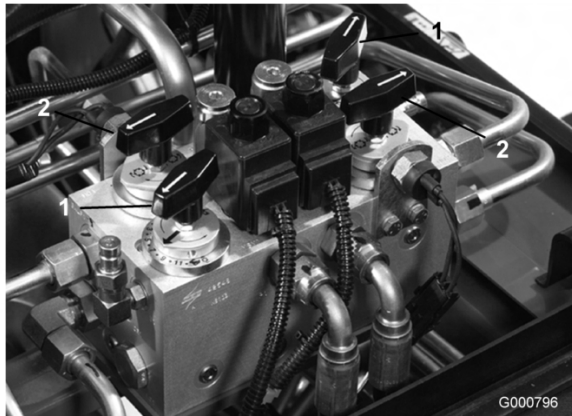


**Figure 12**

1. Hour meter

## Backlap Knobs

The backlap knobs (Figure 13) are used in conjunction with lower mow/raise control lever for backlapping operation. Refer to Backlapping in Cutting Unit Maintenance, page 45.



**Figure 13**

1. Reel control knobs
2. Backlap knobs

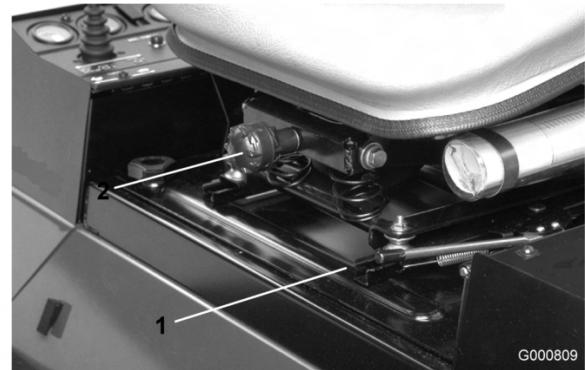
## Reel Speed Controls

Controls RPM of front and rear cutting units (Figure 13). #1 position is for backlapping. Remaining settings are for mowing operations. See decal under seat for proper settings.

## Seat

The seat adjusting lever (Figure 14) allows 4 inch fore and aft adjustment. The seat adjusting knob (Figure 14) adjusts seat for operators weight. To adjust seat fore

and aft, pull lever on left side of seat assembly outward. After moving seat to desired location, release lever to lock seat into position. To adjust for operators weight, turn spring tension knob; clockwise to increase tension, counterclockwise to decrease spring tension.

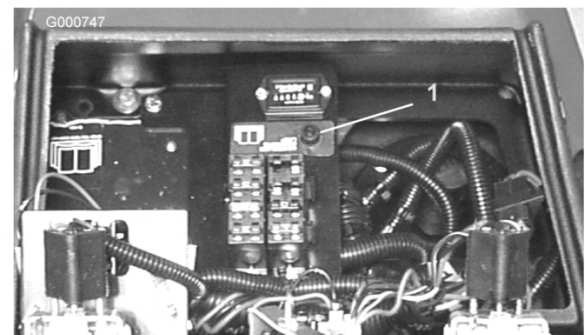


**Figure 14**

1. Seat adjusting lever
2. Seat adjusting knob

## Green Diagnostic Light

The machine is equipped with a diagnostic light which indicates if the electronic controller is functioning correctly. The green diagnostic light (Figure 15) is located under the control panel, next to the fuse block. When the electronic controller is functioning correctly and the key switch is moved to the ON position, the controller diagnostic light will be illuminated. The light will blink if the controller detects a malfunction in the electrical system. The light will stop blinking and automatically reset when the key switch is turned to the OFF position.



**Figure 15**

1. Green diagnostic light

When the controller diagnostic light blinks, one of the following problems has been detected by the controller:

- One of the outputs has been shorted.
- One of the outputs is open circuited.

Using the diagnostic display, determine which output is malfunctioning, refer to Checking Interlock Switches in Operation, page 21.

If the diagnostic light is not illuminated when the key switch is in the On position, this indicates that the electronic controller is not operating. Possible causes are:

- Loopback is not connected.
- The light is burned out.
- Fuses are blown.
- No battery power.

Check electrical connections, input fuses and diagnostic light bulb to determine malfunction. Make sure loopback connector is secured to wire harness connector.

## Diagnostic ACE Display (Optional)

The machine is equipped with an electronic controller which controls most machine functions. The controller determines what function is required for various input switches (i.e. seat switch, key switch, etc.) and turns on the outputs to actuate solenoids or relays for the requested machine function.

For the electronic controller to control the machine as desired, each of the input switches, output solenoids and relays must be connected and functioning properly.

The Diagnostic ACE display is a tool to help the user verify correct electrical functions of the machine.

## Specifications

**Note:** Specifications and design are subject to change without notice.

Width-of-cut, model 03806 and 03807	96 inches (244 cm)
Width-of-cut, model 03808	133 inches (338 cm)
Overall width, Transport	89 inches (226 cm)
Overall width, Operational	110 inches (279 cm)
Overall length	120 inches (305 cm)
Height With ROPS installed	84 inches (213 cm)
Weight*, model 03806	3200 lb (1451 kg)
Weight*, model 03807	3300 lb (1496 kg)
Weight*, model 03808	3950 lb (1792 kg)

\* With 5 blade cutting units and full fluid levels

## Attachments/Accessories

A selection of Toro approved attachments and accessories are available for use with the machine to enhance and expand its capabilities. Contact your Authorized Service Dealer or Distributor or go to [www.Toro.com](http://www.Toro.com) for a list of all approved attachments and accessories.

# Operation

**Note:** Determine the left and right sides of the machine from the normal operating position.

## Checking the Engine Oil

The engine is shipped with oil in the crankcase; however, the oil level must be checked before and after the engine is first started.

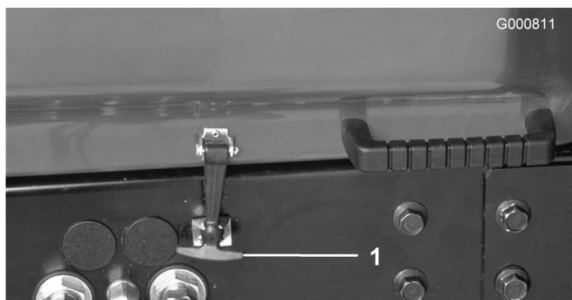
Crankcase capacity is approximately 7.5 qt. (7 l) with the filter.

Use high-quality engine oil that meets the following specifications:

- API Classification Level Required: CH-4, CI-4 or higher.
- Preferred oil: SAE 15W-40 (above 0°F)
- Alternate oil: SAE 10W-30 or 5W-30 (all temperatures)

**Note:** Toro Premium Engine oil is available from your distributor in either 15W-40 or 10W-30 viscosity. See the parts catalog for part numbers.

1. Park machine on a level surface. Release hood latch and open hood (Figure 16).

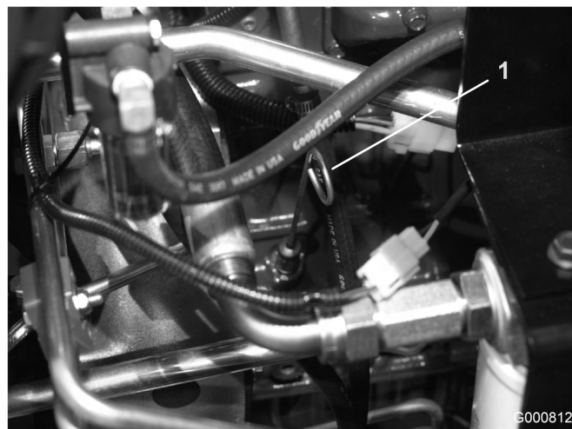


**Figure 16**

1. Hood latch

2. Remove dipstick (Figure 17), wipe clean and reinstall dipstick. Pull it out again and check oil

level on dipstick: Oil level should be up to FULL mark on dipstick.



**Figure 17**

1. Dipstick

3. If oil level is low, remove filler cap (Figure 18) and add oil until level reaches FULL mark on dipstick. Do not overfill.



**Figure 18**

1. Filler cap

4. Install filler cap.
5. Close hood and secure latch.

## Checking the Cooling System

Clean debris off screen, oil cooler and front of radiator daily, more often if conditions are extremely dusty and dirty; refer to Removing Debris in Cooling System Maintenance, page 41.

The cooling system is filled with a 50/50 solution of water and permanent ethylene glycol antifreeze. Check level of coolant in radiator and expansion tank at the beginning of each day before starting the engine. Capacity of cooling system is 10 quarts (9.4 l).

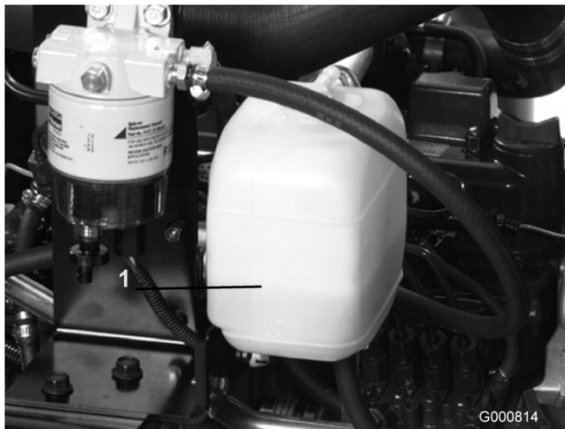


If the engine has been running, pressurized hot coolant can escape and cause burns if the radiator cap is removed.

Allow the engine to cool at least 15 minutes or until the radiator cap is cool enough to touch without burning hands.

1. Carefully remove radiator cap and expansion tank cap (Figure 19).
2. Check level of coolant in radiator and in expansion tank (Figure 19).

Radiator should be filled to the top of the filler neck and the expansion tank filled to the Full mark.



**Figure 19**

1. Expansion tank

3. Fill expansion tank to the Full mark and radiator to the top of the filler neck. **Do not overfill the expansion tank.**

**Note:** If air is trapped in system, remove vent plug (Figure 20), from top of radiator side tank,

to allow trapped air to escape. Reinstall vent plug using Teflon thread sealant.



**Figure 20**

1. Vent plug

4. Install radiator cap and expansion tank cap.
5. Close hood and secure latch.

## Filling the Fuel Tank

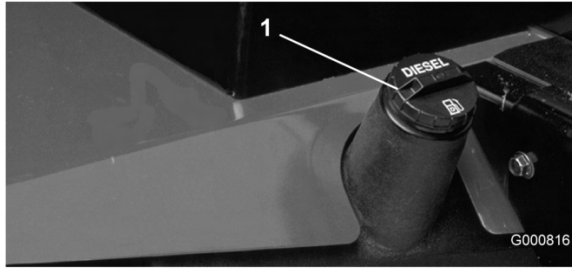


Under certain conditions, diesel fuel and fuel vapors are highly flammable and explosive. A fire or explosion from fuel can burn you and others and can cause property damage.

- Use a funnel and fill the fuel tank outdoors, in an open area, when the engine is off and is cold. Wipe up any fuel that spills.
- Do not fill the fuel tank completely full. Add fuel to the fuel tank until the level is 1 in. (25 mm) below the bottom of the filler neck. This empty space in the tank allows the fuel to expand.
- Never smoke when handling fuel, and stay away from an open flame or where fuel fumes may be ignited by a spark.
- Store fuel in a clean, safety-approved container and keep the cap in place.

Capacity of fuel tank is 15 gal (57 l).

1. Remove fuel tank cap (Figure 21).



**Figure 21**

1. Fuel tank cap

2. Fill tank to about one inch below top tank, not filler neck with No. 2 diesel fuel. Then install cap.

## Checking the Hydraulic Fluid

The machine's reservoir is filled at the factory with approximately 8.5 U.S. gallons (32 l) of high quality hydraulic fluid. Check the level of the hydraulic fluid before the engine is first started and daily thereafter. The recommended replacement fluid is as follows:

**Toro Premium All Season Hydraulic Fluid**  
(Available in 5 gallon pails or 55 gallon drums. See parts catalog or Toro distributor for part numbers.)

Alternate fluids: If the Toro fluid is not available, other fluids may be used provided they meet all the following material properties and industry specifications. We do not recommend the use of synthetic fluid. Consult with your lubricant distributor to identify a satisfactory product. Note: Toro will not assume responsibility for damage caused by improper substitutions, so use only products from reputable manufacturers who will stand behind their recommendation.

### High Viscosity Index/Low Pour Point Anti-wear Hydraulic Fluid, ISO VG 46

#### Material Properties:

Viscosity, ASTM D445	cSt @ 40°C 44 to 48 cSt @ 100°C 7.9 to 8.5
Viscosity Index ASTM D2270	140 to 160
Pour Point, ASTM D97	-34°F to -49°F

#### Industry Specifications:

Vickers I-286-S (Quality Level), Vickers M-2950-S (Quality Level), Denison HF-0

**Note:** Many hydraulic fluids are almost colorless, making it difficult to spot leaks. A red dye additive for the hydraulic system oil is available in 2/3 oz. (20 ml) bottles. One bottle is sufficient for 4-6 gal (15-22 l) of hydraulic oil. Order part no. 44-2500 from your authorized Toro distributor.

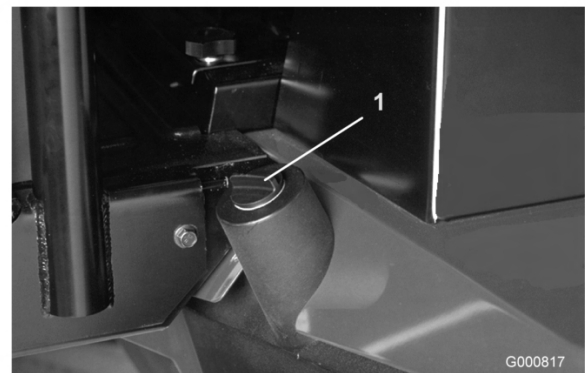
### Biodegradable Hydraulic Fluid - Mobil 224H

**Toro Biodegradable Hydraulic Fluid** (Available in 5 gallon pails or 55 gallon drums. See parts catalog or Toro distributor for part numbers.)

**Alternate fluid:** Mobil EAL 224H

**Note:** This is vegetable-oil based biodegradable oil tested and approved by Toro for this model. This fluid is not as resistant to high temperatures as standard fluid, so install an oil cooler if required by the operator manual and follow recommended fluid change intervals with this fluid. Contamination by mineral-based hydraulic fluids will change the biodegradability and toxicity of this oil. When changing from standard fluid to the biodegradable type, be certain to follow the approved flushing procedure. Contact your local Toro Distributor for details.

1. Position machine on a level surface, lower the cutting units and stop the engine.
2. Clean area around filler neck and cap of hydraulic tank (Figure 22). Remove cap from filler neck.



**Figure 22**

1. Hydraulic tank cap

3. Remove dipstick from filler neck and wipe it with a clean rag. Insert dipstick into filler neck; then remove it and check level of fluid. Fluid level should be within 1/4 inch of mark on dipstick.
4. If level is low, add appropriate fluid to raise level to full mark.
5. Install dipstick and cap onto filler neck.

## Checking the Tire Pressure

The tires are over-inflated for shipping. Therefore, release some of the air to reduce the pressure. Correct air pressure in the front and rear tires is 15-20 psi.

**Important:** Maintain even pressure in all tires to ensure a good quality-of-cut and proper machine performance. Do not under inflate.

## Checking the Reel to Bedknife Contact

Each day before operating, check reel to bedknife contact, regardless if quality of cut had previously been acceptable. There must be light contact across the full length of the reel and bedknife (refer to Adjusting Reel to Bedknife in Cutting Unit *Operator's Manual*).

## Starting and Stopping

1. Sit on the seat, keep foot off traction pedal. Ensure parking brake is engaged, traction pedal is in Neutral, throttle is in Slow position and the Enable/Disable switch is in the Disable position.
2. Turn ignition switch to On/Preheat position. An automatic timer will control preheat for approximately 6 seconds. After preheat, turn key to Start position. Crank the engine for no longer than 15 seconds. Release key when engine starts. If additional preheat is required, turn key to Off position then to On/Preheat position. Repeat process as required.
3. Run engine at idle speed or partial throttle until engine warms up.
4. To stop, move all controls to Neutral and set parking brake. Return throttle to the idle position, turn key to OFF and remove it from switch.

**Important:** Allow engine to idle for 5 minutes before shutting it off after a full load operation. Failure to do so may lead to turbo-charger trouble.

**Note:** We recommend that anytime the machine is parked (short or long term) the cutting units should be lowered to the ground. This relieves pressure from the lift circuit and eliminates the risk of the cutting units accidentally lowering to the ground.

## Bleeding the Fuel System

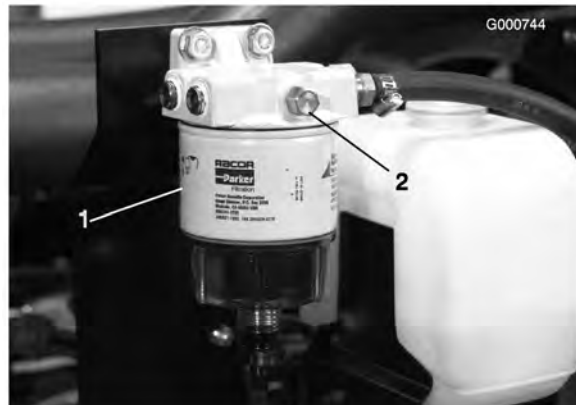
1. Park the machine on a level surface. Make sure fuel tank is at least half full.
2. Unlatch and raise hood.



Under certain conditions, diesel fuel and fuel vapors are highly flammable and explosive. A fire or explosion from fuel can burn you and others and can cause property damage.

- Use a funnel and fill the fuel tank outdoors, in an open area, when the engine is off and is cold. Wipe up any fuel that spills.
- Do not fill the fuel tank completely full. Add fuel to the fuel tank until the level is 1 in. (25 mm) below the bottom of the filler neck. This empty space in the tank allows the fuel to expand.
- Never smoke when handling fuel, and stay away from an open flame or where fuel fumes may be ignited by a spark.
- Store fuel in a clean, safety-approved container and keep the cap in place.

3. Open vent plug on the fuel filter/water separator (Figure 23).

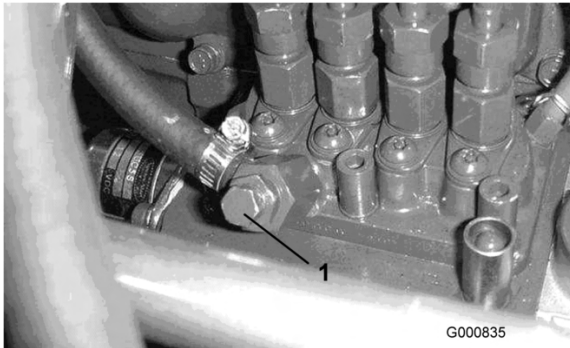


**Figure 23**

1. Fuel filter/water separator    2. Vent plug

4. Turn key in ignition switch to the On position. Electric fuel pump will begin operation, thereby forcing air out around vent plug. Leave key in On position until a solid stream of fuel flows out around plug. Tighten plug and turn key to OFF.

- Open the air bleed screw on the fuel injection pump (Figure 24).



**Figure 24**

- Fuel injection pump bleed screw

- Turn key in ignition switch to the On position. Electric fuel pump will begin operation, thereby forcing air out around air bleed screw. Leave key in On position until a solid stream of fuel flows out around screw. Tighten screw and turn key to Off.

**Note:** Normally, engine should start after above bleeding procedures are followed. However, if engine does not start, air may be trapped between injection pump and injectors; refer to Bleeding Air From Injectors in Fuel System Maintenance, page 35.

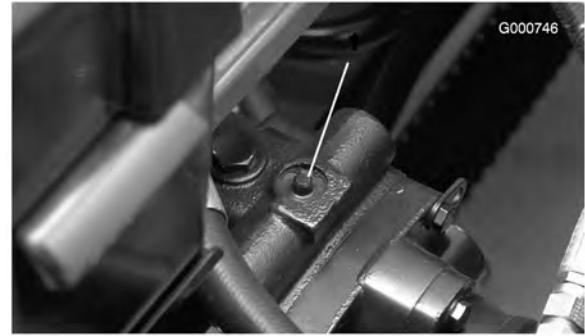
## Pushing or Towing the Machine

In an emergency, the machine can be moved by actuating the bypass valve in the variable displacement hydraulic pump and pushing or towing the machine.

**Important:** Do not push or tow the machine faster than 2-3 mph (3-4.8 km/h) because internal transmission damage may occur. The bypass valve must be open whenever the machine is pushed or towed.

- The bypass valve is located on top of variable displacement pump (Figure 25). Rotate the valve 90°, in either direction, to open and allow oil to bypass internally. Because fluid is bypassed, the

machine can be moved slowly without damaging the transmission.



**Figure 25**

- Bypass valve

- Close the bypass valve before starting the engine. However, do not exceed 5-8 ft.-lb. (7-11 N m) torque to close the valve.

**Important:** Running the engine with the bypass valve open will cause the transmission to overheat.

## Checking the Interlock Switches



If safety interlock switches are disconnected or damaged the machine could operate unexpectedly causing personal injury.

- Do not tamper with the interlock switches.
- Check the operation of the interlock switches daily and replace any damaged switches before operating the machine.
- Replace switches every two years regardless of whether they are operating properly or not.

The purpose of the interlock switches are to prevent the engine from cranking or starting unless the traction pedal is in Neutral, the Enable/Disable switch is in Disable and the Lower Mow/Raise control is in the neutral position. In addition, the engine will stop when the traction pedal is depressed with either the operator off the seat or the parking brake engaged.

### To verify interlock switch function:

- Park machine on a level surface, lower the cutting units, stop the engine and engage the parking brake.

- Open control panel cover. Locate wire harness and loopback connector. Carefully unplug loopback connector from harness connector (Figure 26).



**Figure 26**

- Loop-back connector

- Connect the Diagnostic ACE display connector to the harness connector (Figure 27). Make sure correct overlay decal is positioned on Diagnostic ACE display.



**Figure 27**

- Diagnostic ACE

- Turn the key switch to the On position, but do not start machine.

**Note:** The red text on the overlay decal refers to input switches and the green text refers to outputs.

- The “inputs displayed” LED, on lower right column of the Diagnostic ACE, should be illuminated. If “outputs displayed” LED is illuminated, press and release the toggle button, on Diagnostic ACE, to change LED to “inputs displayed”. Do not hold button down.
- The Diagnostic ACE will illuminate the LED associated with each of the inputs when that input switch is closed.

Individually, change each of the switches from open to closed (i.e., sit on seat, engage traction

pedal, etc.), and note that the appropriate LED on Diagnostic ACE will blink on and off when corresponding switch is closed. Repeat on each switch that is possible to be changed by hand.

- If switch is closed and appropriate LED does not turn on, check all wiring and connections to switch and/or check switches with an ohm meter. Replace any damaged switches and repair any damaged wiring.

The Diagnostic ACE also has the ability to detect which output solenoids or relays are turned on. This is a quick way to determine if a machine malfunction is electrical or hydraulic.

### To verify output function:

- Park machine on a level surface, lower the cutting units, stop the engine and engage the parking brake.
- Open control panel cover. Locate wire harness and connectors near controller. Carefully unplug loopback connector from harness connector.
- Connect the Diagnostic ACE connector to the harness connector. Make sure correct overlay decal is positioned on Diagnostic ACE.
- Turn the key switch to the On position, but do not start machine.

**Note:** The red text on the overlay decal refers to input switches and the green text refers to outputs.

- The “outputs displayed” LED, on lower right column of Diagnostic ACE, should be illuminated. If “inputs displayed”; LED is illuminated, press the toggle button, on Diagnostic ACE, to change LED to “outputs displayed.”

**Note:** It may be necessary to toggle between “inputs displayed” and “outputs displayed” several times to do the following step. To toggle back and forth, press toggle button once. This may be done as often as required. Do not hold the button.

- Sit on the seat and attempt to operate the desired function of the machine. The appropriate output LED’s should illuminate to indicate that the ECU is turning on that function. (Refer to Hydraulic Solenoid Valve Functions to be certain of the specified output LEDs.)

**Note:** If any output LED is blinking, this indicates an electrical problem with that OUTPUT. Repair/replace defective electrical parts immediately. To reset a blinking LED, turn the key switch “Off”, then back “On” and clear the controllers fault memory (Refer to Clearing the Fault Memory in Fault Memory and Retrieval).

If no output LEDs are blinking, but the correct output LED's do not illuminate, verify that the required input switches are in the necessary positions to allow that function to occur. Verify correct switch function.

If the output LEDs are on as specified, but the machine does not function properly, this indicates a non-electrical problem. Repair as necessary.

**Note:** Due to electrical system constraints, the output LED's for "Start", "Preheat" and "ETR/ALT" may not blink even though an electrical problem may exist for those functions. If the machine problem appears to be with one of these functions, be certain to check the electrical circuit with a volt/ohm meter to verify that no electrical problem exists to these functions.

If each input switch is in the correct position and functioning correctly, but the output LEDs are not correctly illuminated, this indicates an ECU problem. If this occurs, contact your Toro Distributor for assistance.

## Fault Memory and Retrieval

If the Controller senses a **fault** on one of the **output solenoids**, it will flash the machines diagnostic Lamp (Reel Diagnostic Lamp on console or Green Diagnostic Lamp under console) and store the fault into the Controllers (ECU) memory. The fault can then be retrieved and viewed with the Diagnostic ACE hand held tool or a lap top/PC at anytime. The Controller will store one (1) fault at a time and will not store another different fault until the first fault is cleared.

### Retrieving Fault Information

#### Retrieving Stored Faults (Do not sit in seat)

1. Rotate ignition key to Off position.
2. Connect the Hand held Diagnostic Tool to the desired Controller Loopback Connector (use the proper overlay).
3. Move the Joystick to the Raise position and hold.
4. Rotate ignition key to On position, and continue to hold the Joystick in Raise position until the top left Diagnostic Tool light comes on (approx. 2 seconds).
5. Release the Joystick to the center position.
6. Hand held Tool will now playback the fault retained in the Controller memory.

**Important:** The display will show eight (8) individual records with the fault displayed on the 8th record. Each record will be displayed for 10 seconds. Be sure to have the Diagnostic

**Tool display on Outputs to see fault. The Problem circuit will be flashing. Records will repeat until key is turned off. Unit will not start in this mode.**

#### Clearing the Fault Memory (Diagnostic Tool not required)

7. Rotate ignition key to Off position.
8. Turn Backlap Switch to the Front or Rear Backlap position.
9. Turn the Reel Control Switch to Enable position.
10. Move the Joystick to the Raise position and hold.
11. Turn the ignition key to On, and continue to hold the Joystick in the Raise position until the Reel Control Lamp starts to flash (approx. 2 seconds).
12. Release the Joystick and turn the Key Off. Memory is now cleared.
13. Turn the Backlap Switch to Off and Enable Switch to Disable position.

**Important:** The Diagnostic ACE display must not be left connected to the machine. It is not designed to withstand the environment of the machine's every day use. When done using Diagnostic ACE, disconnect it from the machine and reconnect loopback connector to harness connector. Machine will not operate without loopback connector installed on harness. Store Diagnostic ACE in dry, secure location in shop, not on machine.

## Hydraulic Solenoid Valve Functions

Use the list below to identify and describe the different functions of the solenoids in the hydraulic manifold. Each solenoid must be energized to allow function to occur.

Solenoid	Function
MSV1	Front reel circuit
MSV2	Rear reel circuit
SV4	Lift front wing cutting units
SV3	Lift front center cutting unit
SV5	Lift rear cutting units
SV1	Pressurize raise/lower hydraulic circuit
SV2	Direction: ON=Raise, OFF= Lower
SV 6	Left rear wing cutting unit

Solenoid	Function
SV 7	Right rear wing cutting unit
SV8	Load Holding

## Operating Tips

### Familiarization

Before mowing grass, practice operating machine in an open area. Start and stop the engine. Operate in forward and reverse. Lower and raise cutting units and engage and disengage reels. When you feel familiar with the machine, practice operating up and down slopes at different speeds.

The brakes can be used to assist in turning the machine. However, use them carefully, especially on soft or wet grass conditions because the turf may be torn accidentally. Individual turning brakes may also be used to help maintain traction. For example, in some slope conditions, the uphill wheel slips and loses traction. If this situation occurs, depress uphill turn pedal gradually and intermittently until the uphill wheel stops slipping, thus, increasing traction on the downhill wheel.

**Important:** Before mowing grass, practice operating the machine in turns. Turf damage in turns may occur especially under soft or wet grass conditions if the turn is completed at a high speed or at a small turning radius. Maintain a speed below 3 mph during a turn and a turning radius greater than 8 feet to minimize turf damage from tires or cutting units. Mounting the cutting units with the steering pin in the front mounting hole will allow the cutting unit to steer itself as the traction unit turns providing optimum maneuverability and cutting performance in turns. During cross-cutting of fairways, a tear drop shape turn is recommended to increase cutting productivity and minimize turf damage.



When operating the machine, always use the seat belt and ROPS together. Do not use a seat belt without a ROPS.

### Warning System

If a warning light comes on during operation, stop the machine immediately and correct the problem before continuing operation. Serious damage could occur if the machine is operated with a malfunction.

**Important:** The Red Diagnostic Light, on the steering tower, indicates when the glow plugs are

On. The machine should not be started until the glow plug cycle is complete.

### Mowing

Start engine and move throttle to FAST so engine is running at maximum speed. Move the Enable/Disable switch to ENABLE and use the LOWER MOW/RAISE lever to control the cutting units (front cutting units are timed to lower before the rear cutting units). To move forward and cut grass, press traction pedal forward. Maintain a speed which does not result in the Reel Control Light being illuminated. Gradually increase or decrease traction speed to ensure proper clip is maintained.

### Transport

Move the Enable/Disable switch to Joy Stick Disable (mid position), lock brake pedals together and raise the cutting units to the transport position. Be careful when driving between objects so you do not accidentally damage the machine or cutting units. Use extra care when operating machine on slopes. Drive slowly and avoid sharp turns on slopes to prevent roll overs. The cutting units should be lowered when going downhill for steering control.

# Maintenance

**Note:** Determine the left and right sides of the machine from the normal operating position.

## ***Recommended Maintenance Schedule(s)***

<b>Maintenance Service Interval</b>	<b>Maintenance Procedure</b>
After the first use	<ul style="list-style-type: none"> <li>• Check the torque of the wheel nuts or bolts (after the first 1–4 hours of operation and then after 10 hours of operation).</li> </ul>
After the first 50 operating hours	<ul style="list-style-type: none"> <li>• Change the engine oil and oil filter.</li> </ul>
After the first 200 operating hours	<ul style="list-style-type: none"> <li>• Change the planetary gear drive oil.</li> <li>• Change the planetary gear drive oil.</li> <li>• Change the rear axle lubricant.</li> </ul>
Before each use or daily	<ul style="list-style-type: none"> <li>• Check the engine oil level.</li> <li>• Check and clean the cooling system.</li> <li>• Check the hydraulic fluid level.</li> <li>• Check the tire pressure.</li> <li>• Check the reel to bedknife contact.</li> <li>• Check the interlock switches.</li> <li>• Drain the fuel filter/water separator.</li> <li>• Remove debris from the rear screen, oil cooler, and radiator (more frequently in dirty conditions).</li> <li>• Inspect the hydraulic lines and hoses for leaks, kinked lines, loose mounting supports, wear, loose fittings, weather deterioration, and chemical deterioration.</li> </ul>
Every 50 hours	<ul style="list-style-type: none"> <li>• Grease the bearings and bushings.</li> <li>• Check the condition of the battery.</li> </ul>
Every 100 hours	<ul style="list-style-type: none"> <li>• Inspect and tighten the cooling system hoses and connections.</li> <li>• Check the condition and tension of the alternator belt.</li> </ul>
Every 150 hours	<ul style="list-style-type: none"> <li>• Change the engine oil and oil filter.</li> </ul>
Every 200 hours	<ul style="list-style-type: none"> <li>• Check the torque of the wheel nuts or bolts.</li> </ul>
Every 400 hours	<ul style="list-style-type: none"> <li>• Service the air cleaner. (Service the air cleaner earlier if the air cleaner indicator shows red. Service it more frequently in extremely dirty or dusty conditions.)</li> <li>• Check the fuel lines and connections.</li> <li>• Replace the fuel filter canister.</li> <li>• Replace the fuel pre-filter.</li> <li>• Check the rear axle lubricant level.</li> </ul>
Every 800 hours	<ul style="list-style-type: none"> <li>• Change the planetary gear drive oil.</li> <li>• Change the planetary gear drive oil.</li> <li>• Change the rear axle lubricant.</li> <li>• Check the rear wheel toe-in.</li> <li>• Change the hydraulic fluid.</li> </ul>

Maintenance Service Interval	Maintenance Procedure
Yearly	<ul style="list-style-type: none"> <li>Change the planetary gear drive oil.</li> </ul>
Every 2 years	<ul style="list-style-type: none"> <li>Drain and clean the fuel tank.</li> <li>Drain and flush the cooling system.</li> <li>Replace all moving hoses.</li> <li>Drain/flush the hydraulic tank.</li> </ul>

**Important:** Refer to your engine Operator's Manual for additional maintenance procedures.



If you leave the key in the ignition switch, someone could accidentally start the engine and seriously injure you or other bystanders.

Remove the key from the ignition and disconnect the wire from the spark plug before you do any maintenance. Set the wire aside so that it does not accidentally contact the spark plug.

## Service Interval Chart

**REELMASTERS**  
6500-D / 6700-D  
QUICK REFERENCE AID

CHECK/SERVICE (daily)

1. OIL LEVEL, ENGINE
2. OIL LEVEL, HYDRAULIC TANK
3. COOLANT LEVEL, RADIATOR
4. FUEL /WATER SEPARATOR
5. AIR FILTER SERVICE INDICATOR
6. RADIATOR SCREEN
7. BRAKE FUNCTION
8. TIRE PRESSURE (15-20 PSI)

CHECK/SERVICE  
SEE OPERATOR'S MANUAL

9. BATTERY
10. BELTS (FAN, ALT.)
11. PLANETARY GEAR DRIVE
12. REAR AXLE OIL FILL\*\*
13. REAR AXLE OIL CHECK (2)\*\*

**FLUID SPECIFICATIONS/CHANGE INTERVALS**

SEE OPERATOR'S MANUAL FOR INITIAL CHANGES.	FLUID TYPE	CAPACITY	CHANGE INTERVAL FLUID	FILTER	FILTER PART NO.
A. ENGINE OIL	SAE 10W-30CD	7.5 QTS.	100 HRS.	100 HRS.	99-8384
B. HYD. CIRCUIT OIL	MOBIL DTE15M	9 GALS.*	800 HRS.	SEE SERVICE INDICATOR	94-2621
C. PRIMARY AIR FILTER	---	---	---	SEE SERVICE INDICATOR	93-9162
D. SAFETY AIR FILTER	---	---	---	SEE OPERATOR'S MANUAL	93-9163
E. FILTER, IN-LINE FUEL	---	---	---	400 HRS.	99-8358
F. FUEL TANK	NO. 2-Diesel	15 GALS.	Drain and flush, 2 yrs.		
G. COOLANT	50/50 ETHYLENE GLYCOL / WATER	2.5 GALS.	Drain and flush, 2 yrs.		
H. PLANETARY GEAR DRIVE	SAE85W-140	16 OZ.	800 HRS.	---	---
I. REAR AXLE OIL**	SAE85W-140	80 OZ.	800 HRS.	---	---
J. WATER SEPARATOR	---	---	---	400 HRS.	98-9764

\* INCLUDES FILTER, CHECK DIP STICK, DO NOT OVER FILL. \*\*4WD ONLY. 105-0134

G000761

Figure 28

# Daily Maintenance Checklist

Duplicate this page for routine use.

Maintenance Check Item	For the week of:						
	Mon.	Tues.	Wed.	Thurs.	Fri.	Sat.	Sun.
Check safety interlock operation.							
Check brake operation.							
Check engine oil and fuel level.							
Check cooling system fluid level.							
Drain the water/fuel separator.							
Check the air filter restriction indicator.							
Check the radiator and screen for debris.							
Check unusual engine noises. <sup>1</sup>							
Check unusual operating noises.							
Check the transmission oil level.							
Check the hydraulic system oil level.							
Check the hydraulic filter indicator. <sup>2</sup>							
Check the hydraulic hoses for damage.							
Check for fluid leaks.							
Check the tire pressure.							
Check instrument operation.							
Check the reel-to-bedknife adjustment.							
Check the height-of-cut adjustment.							
Lubricate all grease fittings. <sup>3</sup>							
Touch up damaged paint.							

1. Check the glow plug and injector nozzles if hard starting, excess smoke, or rough running is noted.
2. Check with the engine running and oil at operating temperature.
3. Immediately after every washing, regardless of the interval listed.

## Lubrication

### Greasing the Bearings and Bushings

The machine has grease fittings that must be lubricated regularly with No. 2 General Purpose Lithium Base Grease. If machine is operated under normal conditions, lubricate all bearings and bushings after every 50 hours of operation or immediately after every washing.

The grease fitting locations and quantities are:

- Cutting unit carrier frame and pivot (2 ea.) (Figure 29)



**Figure 29**

- Rear axle tie rod (2) (Figure 30)
- Steering cylinder ball joints (2) (Figure 30)
- King pin bushings (2) (Figure 30). **The top fitting on the king pin should only be lubricated annually (2 pumps).**



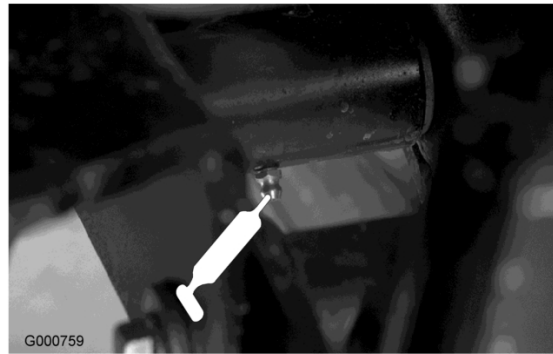
**Figure 30**

1. Top fitting on king pin

- Front lift cylinders (3) (Figure 31 and Figure 32)



**Figure 31**



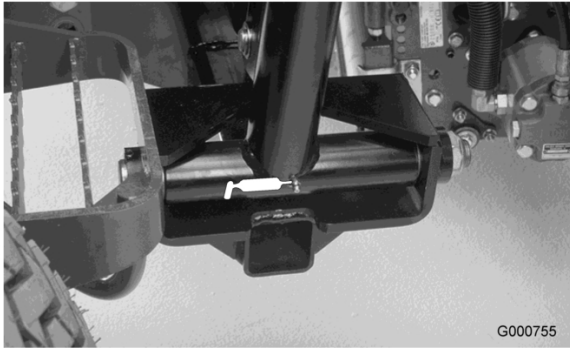
**Figure 32**

- Rear lift cylinder pivot (2) (Figure 33)



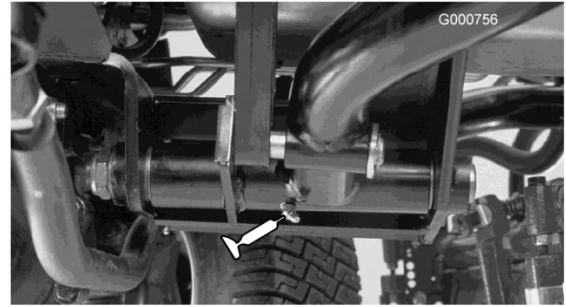
**Figure 33**

- Lift arm pivot (3) (Figure 34)



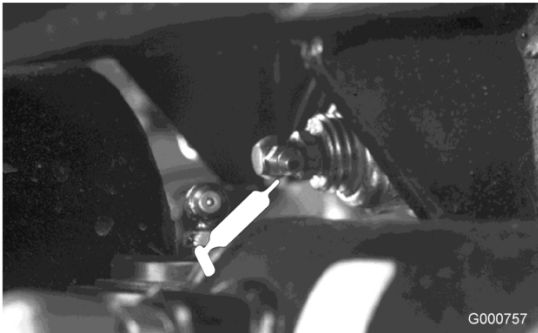
**Figure 34**

- Rear lift arm pivots (2) (Figure 36)



**Figure 36**

- 
- Rear axle pivot (Figure 35)



**Figure 35**

- 
- Brake pedal shaft (1) (Figure 37)



**Figure 37**

---

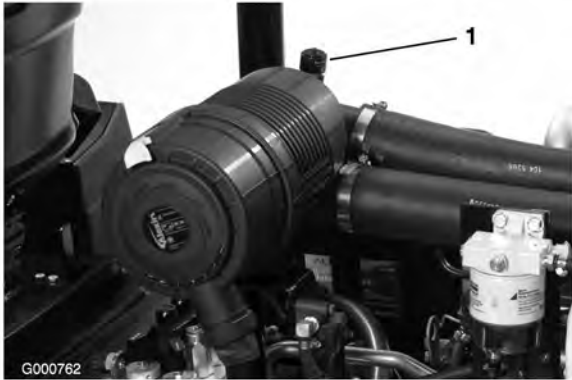
## ***Engine Maintenance***

### **Servicing the Air Cleaner**

Check the air cleaner body for damage which could cause an air leak. Replace if damaged. Check the whole intake system for leaks, damage or loose hose clamps.

Service the air cleaner filter only when the service indicator (Figure 38) requires it. Changing the air filter

before it is necessary only increases the chance of dirt entering the engine when the filter is removed.



**Figure 38**

1. Air cleaner indicator

---

**Important:** Be sure the cover is seated correctly and seals with the air cleaner body.

1. Pull the latch outward and rotate the air cleaner cover counterclockwise (Figure 39).



**Figure 39**

1. Air cleaner latch
2. Air cleaner cover

2. Remove the cover from the air cleaner body. Before removing the filter, use low pressure air (40 psi, clean and dry) to help remove large accumulations of debris packed between outside of primary filter and the canister. **Avoid using high pressure air which could force dirt through the filter into the intake tract.**

This cleaning process prevents debris from migrating into the intake when the primary filter is removed.

3. Remove and replace the primary filter (Figure 40).  
Cleaning of the used element is not recommended due to the possibility of damage to the filter media. Inspect the new filter for shipping damage,

checking the sealing end of the filter and the body. **Do not use a damaged element.** Insert the new filter by applying pressure to the outer rim of the element to seat it in the canister. **Do not apply pressure to the flexible center of the filter.**

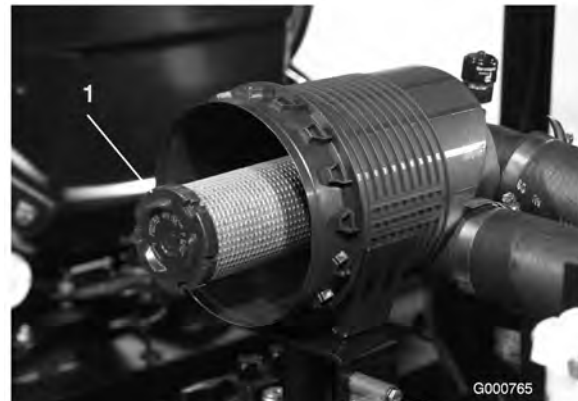


**Figure 40**

1. Air cleaner primary filter

---

**Important:** Never attempt to clean the safety filter (Figure 41). Replace the safety filter with a new one after every three primary filter services.



**Figure 41**

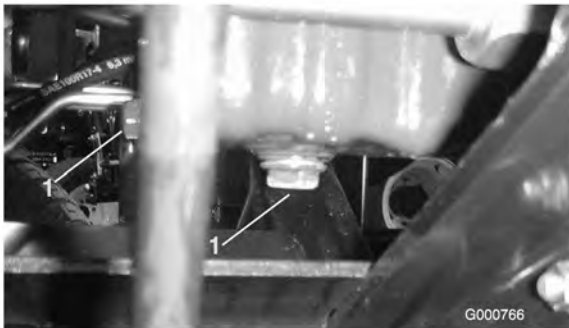
1. Air cleaner safety filter

4. Clean the dirt ejection port located in the removable cover. Remove the rubber outlet valve from the cover, clean the cavity and replace the outlet valve.
5. Install the cover orienting the rubber outlet valve in a downward position—between approximately 5:00 to 7:00 when viewed from the end.
6. Reset the indicator (Figure 38) if it shows red.

## Servicing the Engine Oil and Filter

Change oil and filter initially after the first 50 hours of operation, thereafter change oil and filter every 150 hours.

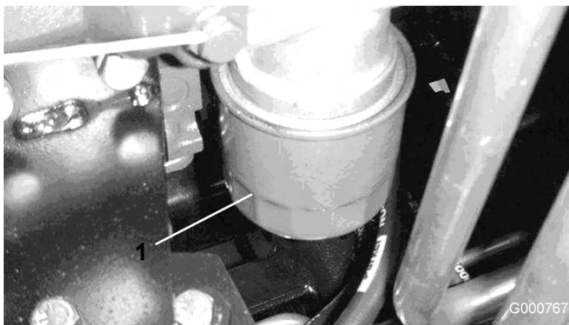
1. Remove drain plug (Figure 42) and let oil flow into drain pan. When oil stops, install drain plug.



**Figure 42**

1. Drain plugs

2. Remove oil filter (Figure 43). Apply a light coat of clean oil to the new filter seal before screwing it on. Do not over-tighten.



**Figure 43**

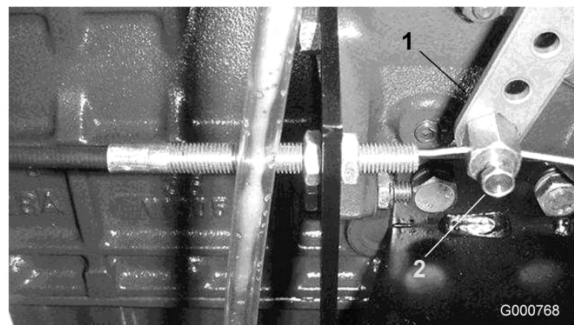
1. Oil filter

3. Add oil to the crankcase. Capacity is 7.5 qt. (7 L) with filter.

## Adjusting Throttle

1. Position throttle lever forward so it stops against seat base slot.

2. Loosen the throttle cable connector on the lever arm at the injection pump (Figure 44).



**Figure 44**

1. Injection pump lever arm 2. Connector

3. Hold the injection pump lever arm against the high idle stop and tighten the cable connector.

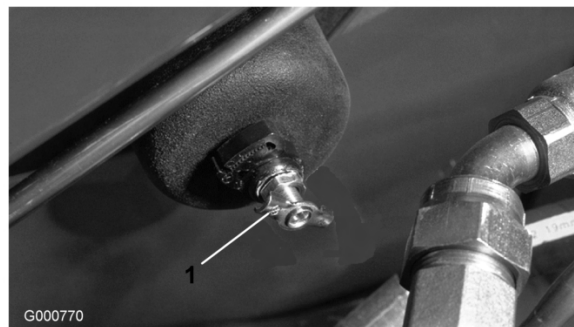
**Note:** When tightened, the cable connector must be free to swivel.

4. Torque the lock nut, used to set the friction device on the throttle lever, to 40-55 in-lb. The maximum force required to operate the throttle lever should be 20 lb.

## Fuel System Maintenance

### Fuel Tank

Drain and clean fuel tank every 2 years. Also, drain and clean tank if fuel system becomes contaminated or if machine is to be stored for an extended period. Use clean fuel to flush out the tank.



**Figure 45**

1. Fuel tank drain



Under certain conditions, diesel fuel and fuel vapors are highly flammable and explosive. A fire or explosion from fuel can burn you and others and can cause property damage.

- Use a funnel and fill the fuel tank outdoors, in an open area, when the engine is off and is cold. Wipe up any fuel that spills.
- Do not fill the fuel tank completely full. Add fuel to the fuel tank until the level is 1/4 to 1/2 in. (6 to 13 mm) below the bottom of the filler neck. This empty space in the tank allows the fuel to expand.
- Never smoke when handling fuel, and stay away from an open flame or where fuel fumes may be ignited by a spark.
- Store fuel in a clean, safety-approved container and keep the cap in place.

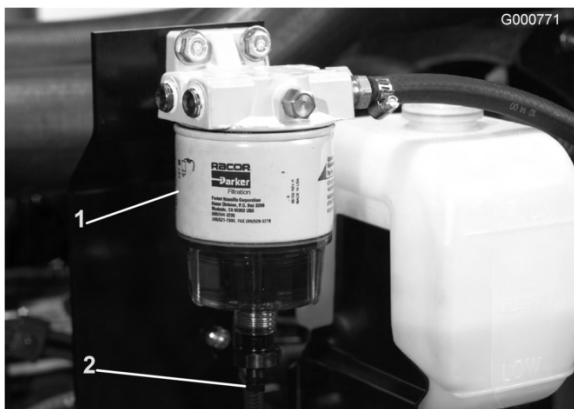
## Fuel Lines and Connections

Check lines and connections every 400 hours or yearly, whichever comes first. Inspect for deterioration, damage, or loose connections.

## Fuel Filter/Water Separator

Drain water or other contaminants from fuel filter/water separator (Figure 46) daily.

1. Locate fuel filter, under hood, and place a clean container under it.
2. Loosen drain plug on bottom of filter canister. Tighten plug after draining.



**Figure 46**

1. Fuel filter/water separator
2. Drain plug

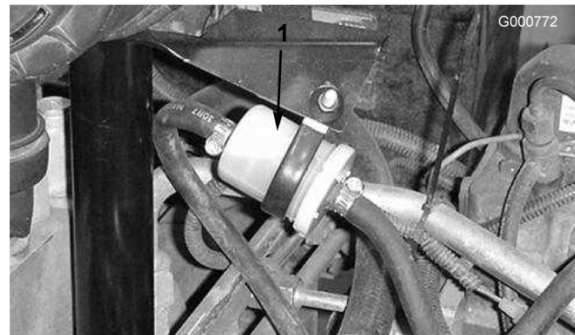
Replace filter canister after every 400 hours of operation.

3. Clean area where filter canister mounts.
4. Remove filter canister and clean mounting surface.
5. Lubricate gasket on filter canister with clean oil.
6. Install filter canister by hand until gasket contacts mounting surface, then rotate an additional 1/2 turn.

## Replacing the Fuel Pre-Filter

Replace the fuel pre-filter (Figure 47), located between fuel the tank and fuel pump, after every 400 operating hours or yearly, whichever occurs first.

1. Clamp both fuel lines that connect to the fuel filter so that fuel cannot drain when the lines are removed.
2. Loosen the hose clamps at both ends of the filter and pull the fuel lines off of the filter.
3. Slide the hose clamps onto the ends of the fuel lines. Push the fuel lines onto the fuel filter and secure them with the hose clamps. Be sure that the arrow on the side of the filter points toward the injection pump.



**Figure 47**

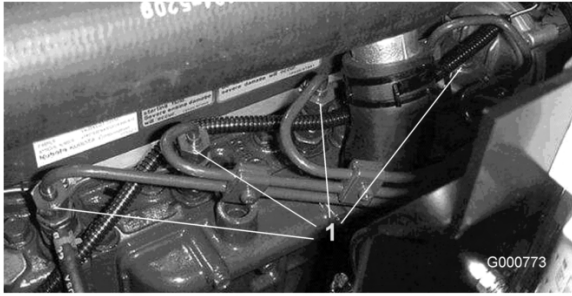
1. Fuel pre-filter

**Note:** Bleeding fuel system is required after replacing the fuel filter/water separator filter or the fuel filter.

## Bleeding Air From Injectors

**Note:** This procedure should be used only if fuel system has been purged of air through normal priming procedures and engine will not start; refer to Bleeding the Fuel System in Operation, page 21.

1. Loosen the pipe connection to the No. 1 nozzle and holder assembly.



**Figure 48**

1. Fuel injectors (4)

2. Move throttle to Fast position.
3. Turn key in key switch to Run position and watch fuel flow around connector. Turn key to Off position when solid flow is observed.
4. Tighten pipe connector securely.
5. Repeat steps 1 through 4 on remaining nozzles.

**Note:** Fan shroud may be easily unbolted from machine to simplify cleaning.

6. Install rear screen and secure latches.

**Note:** Do not use water to clean engine, as damage may occur.

## Electrical System Maintenance

### Battery Care

#### Warning

CALIFORNIA  
Proposition 65 Warning

Battery posts, terminals, and related accessories contain lead and lead compounds, chemicals known to the State of California to cause cancer and reproductive harm. Wash hands after handling.

**Important:** Before welding on a machine, disconnect both cables from the battery, disconnect both wire harness plugs from the electronic control unit and the terminal connector from the alternator to prevent damage to the electrical system.



Battery terminals or metal tools could short against metal tractor components causing sparks. Sparks can cause the battery gasses to explode, resulting in personal injury.

- When removing or installing the battery, do not allow the battery terminals to touch any metal parts of the machine.
- Do not allow metal tools to short between the battery terminals and metal parts of the machine.



Incorrect battery cable routing could damage the tractor and cables causing sparks. Sparks can cause the battery gasses to explode, resulting in personal injury.

- Always disconnect the negative (black) battery cable before disconnecting the positive (red) cable.
- Always connect the positive (red) battery cable before connecting the negative (black) cable.

**Note:** Check battery condition weekly or after every 50 hours of operation. Keep terminals and entire battery case clean because a dirty battery will discharge slowly. To clean the battery, wash the entire case with solution of baking soda and water. Rinse with clear water. Coat the battery posts and cable connectors with Grafo 112X (skin-over) grease (Toro Part No. 505-47) or petroleum jelly to prevent corrosion.



Battery electrolyte contains sulfuric acid which is a deadly poison and causes severe burns.

- Do not drink electrolyte and avoid contact with skin, eyes or clothing. Wear safety glasses to shield your eyes and rubber gloves to protect your hands.
- Fill the battery where clean water is always available for flushing the skin.

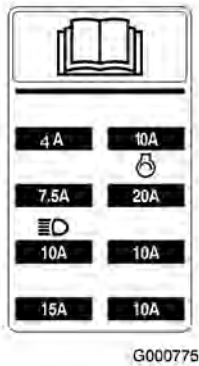
# Fuses

There are 7 fuses in the machines electrical system. They are located below the operators control panel (Figure 49 and Figure 50).

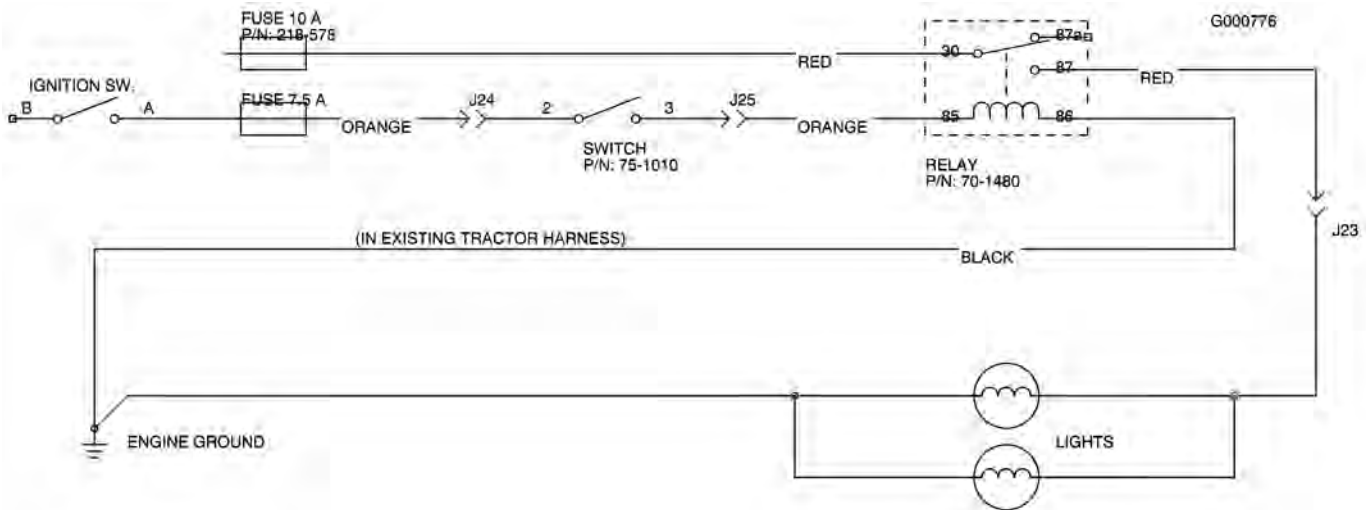


**Figure 49**

1. Fuses



**Figure 50**



**Figure 51**

# Optional Lighting

**Important:** If optional lighting is be added to the traction unit, use the instructions, schematic (Figure 51), and part numbers listed below to prevent damage to the traction units electrical system.

## Installation Instructions

1. Install a relay into the open connector under console.
2. Install light switch.
  - Note:** Punch out in control panel provided for switch installation.
3. Crimp a ring or fork terminal onto each of the orange wires (J 24 & J 25) under console. Secure them to light switch terminals #2 & #3.
4. Splice power (+) wires from lights to red wire at J 23.
5. Secure ground wires from lights to the engine block ground.
6. Install a 10 amp. fuse to fuse block at location shown on fuse block decal. Do not exceed fuse rating.

Switch	Relay
Toro Part No. 75-1010	Toro Part No. 70-1480
Honeywell Part No. 1TL1-2	Hella Part No. 87411 B

## Drive System Maintenance

### Checking the Torque of the Wheel Nuts or Bolts



Failure to maintain proper torque of the wheel nuts could result in personal injury.

Torque the front wheel nuts and rear wheel bolts to 85-100 ft.-lb. after 1-4 hours of operation and again after 10 hours of operation. Torque every 200 hours thereafter.

### Checking the Planetary Gear Drive Oil

1. With machine on level surface, position wheel so the check/drain plug (Figure 52) is at either 2 or 10 o'clock position.

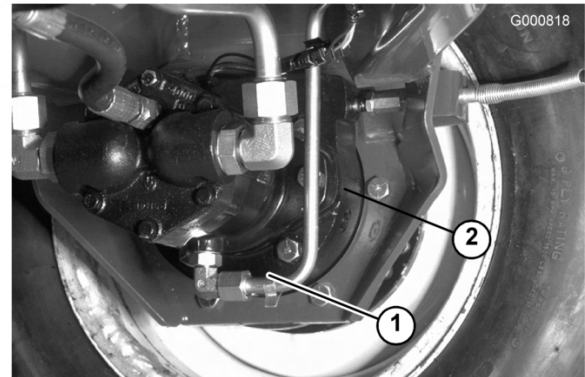


**Figure 52**

1. Check/drain plug

2. Remove the plug on the planetary (Figure 52) and the check plug on the back side of the brake (Figure 53).

Oil should be at the bottom of the check plug hole on front and back side of the brake.



**Figure 53**

1. Brake housing
2. Check plug location

3. Add gear oil to the hole in the planetary, if necessary, to bring the oil up to the proper level. Install the plug.
4. Repeat steps 1 through 3 on the opposite gear assembly.

### Changing the Planetary Gear Drive Oil

Change oil initially after 200 hours operation and every 800 hours, or yearly. Use high quality SAE 85W-140 wt. gear lube as replacement.

1. With machine on level surface, position wheel so the check/drain plug is at lowest position (Figure 54).

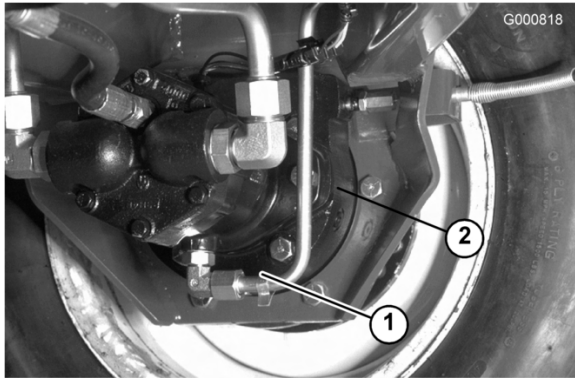


**Figure 54**

1. Drain/check plug

2. Place drain pan under hub, remove plug and allow oil to drain.

- Remove both plugs from the bottom of the brake housing and allow the oil to drain (Figure 55).



**Figure 55**

- Drain plug location
- Check plug location

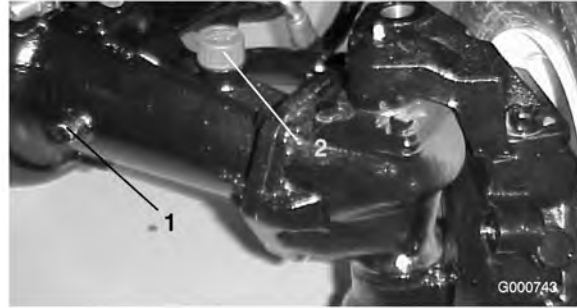
- When all of the oil has drained, install the bottom plug in the brake housing.
- Position the wheel so that the plug hole is at the ten or two o'clock position on the planetary.
- Slowly add approximately 16 oz. (0.5 l) of high quality SAE 85W-140 wt. gear lube to the planetary fill hole (at the ten or two o'clock position) until the level is up to the bottom of the brake housing check hole. Install the plug.
- Repeat the procedure on the opposite planetary/brake assembly.

## Checking the Rear Axle Lubricant

The rear axle is shipped from the factory filled with SAE 85W-140 wt. gear lube. Check level before engine is first started and every 400 hours thereafter. Capacity is 80 oz. Visually inspect for leaks daily.

- Position the machine on a level surface.
- Remove a check plug (Figure 56) from one end of axle and make sure lubricant is up to bottom of hole. If level is low, remove the fill plug (Figure 56)

and add enough lubricant to bring the level up to the bottom of the check plug holes.



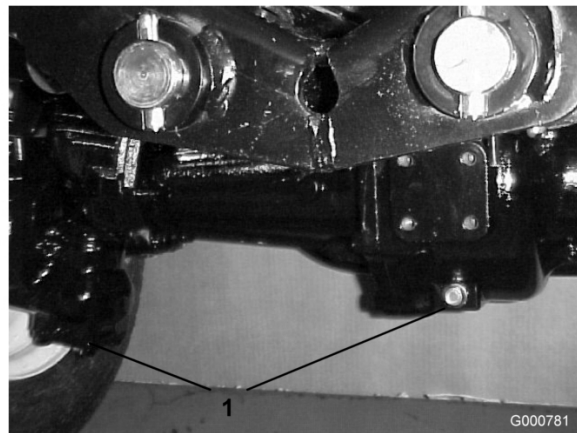
**Figure 56**

- Check plug
- Fill plug

## Changing the Rear Axle Lubricant

Change the oil initially after the first 200 hours of operation and every 800 hours of operation thereafter.

- Position the machine on a level surface.
- Clean the area around the 3 drain plugs, 1 on each end and 1 in the center (Figure 57).



**Figure 57**

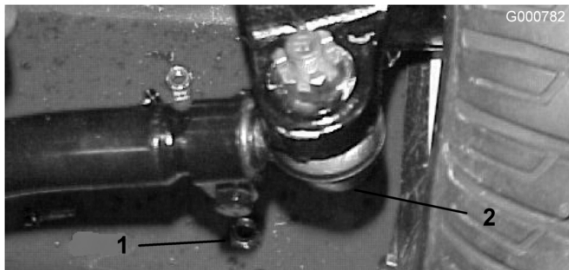
- Drain plug location

- Remove the (3) oil level check plugs and main axle vent cap to ease in draining of the oil.
- Remove the drain plugs and allow the oil to drain into the pans.
- Install the plugs.
- Remove a check plug and fill axle with approximately 80 oz. of 85W-140 gear lube or until lubricant is up to bottom of hole.
- Install check plug.

## Rear Wheel Toe-In

After every 800 operating hours or annually, check the rear wheel toe-in.

1. Measure the center-to-center distance (at axle height) at the front and rear of the steering tires. The front measurement must be 1/8 in. (3 mm) less than the rear measurement.
2. To adjust, remove the cotter pin and nut from either tie rod ball joint. Remove tie rod ball joint from axle case support (Figure 58).
3. Loosen the clamps at both ends of the tie rods (Figure 58).



**Figure 58**

1. Tie rod clamp
  2. Tie rod ball joint
- 
4. Rotate the detached ball joint inward or outward one (1) complete revolution. Tighten clamp at loose end of tie rod.
  5. Rotate the entire tie rod assembly the same direction (inward or outward) one (1) complete revolution. Tighten clamp at connected end of tie rod.
  6. Install the ball joint in the axle case support and tighten the nut finger tight. Measure toe-in.
  7. Repeat procedure if necessary.
  8. Tighten the nut and install a new cotter pin when the adjustment is correct.

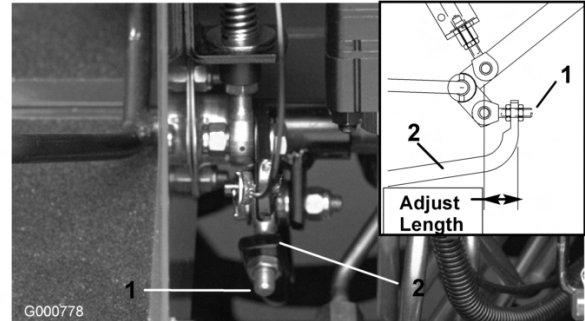
## Adjusting the Traction Drive for Neutral

The machine must not creep when traction pedal is released. If it does creep, an adjustment is required.

1. Park machine on a level surface, shut engine off and lower cutting units to the floor. Depress only the right brake pedal and engage the parking brake.
2. Jack up left side of machine until front tire is off the shop floor. Support machine with jack stands to prevent it from falling accidentally.

**Note:** On 4 wheel drive models, left rear tire must also be off the shop floor.

3. Start engine and allow run at low idle.
4. Adjust jam nuts on pump rod end to move pump control tube forward to eliminate forward creep or rearward to eliminate rearward creep (Figure 59).



**Figure 59**

1. Pump rod
  2. Pump control tube
- 
5. After wheel rotation ceases, tighten jam nuts to secure adjustment.
  6. Stop the engine and release the right brake. Remove jack stands and lower the machine to the shop floor. Test drive the machine to make sure it does not creep.

## Cooling System Maintenance

### Removing Debris

Remove debris from rear screen, oil cooler and radiator daily, clean more frequently in dirty conditions.

**Important:** Never spray water onto a hot engine as damage to engine may occur.

1. Turn engine off, release hood latch and raise hood. Clean engine area thoroughly of all debris. Close hood.

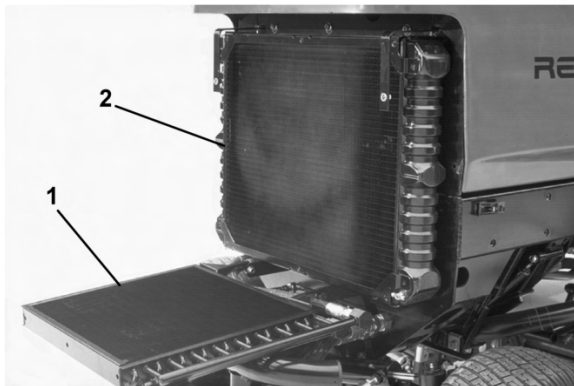
2. Unlatch and remove rear screen (Figure 60). Clean screen thoroughly.



**Figure 60**

1. Rear screen

3. Unscrew knobs and pivot oil cooler rearward (Figure 61). Clean both sides of oil cooler and radiator area thoroughly with compressed air. Do not use water. Open hood and blow debris out toward back of machine. Pivot oil cooler back into position and tighten knobs.



**Figure 61**

1. Oil cooler
2. Radiator

## Maintaining the Cooling System

Capacity of the system is 10 qts. (9.4 l). Always protect cooling system with a 50/50 solution of water and permanent ethylene glycol anti-freeze. Do not use water only in the cooling system.

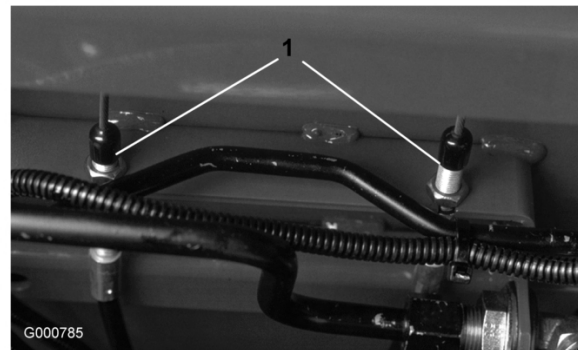
1. After every 100 operating hours, inspect and tighten hose connections. Replace any deteriorated hoses.
2. After every 2 years, drain and flush the cooling system. Add anti-freeze; refer to Checking the Cooling System in Operation, page 21.

## Brake Maintenance

### Adjusting the Service Brakes

Adjust the service brakes when there is more than 1 inch of free travel of the brake pedal, or when the brakes do not work effectively. Free travel is the distance the brake pedal moves before braking resistance is felt.

1. Disengage locking pin from brake pedals so both pedals work independently of each other.
2. To reduce free travel of brake pedals, tighten the brakes by loosening the front nut on the threaded end of the brake cable (Figure 62). Then tighten rear nut to move cable backward until brake pedals have 1/2 to 1 inch of free travel. Tighten front nuts after brakes are adjusted correctly.



**Figure 62**

1. Brake cables

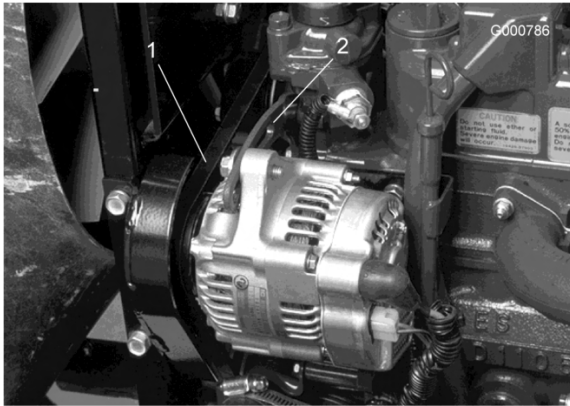
## Belt Maintenance

### Checking the Alternator Belt

Check condition and tension of alternator belt after every 100 hours of operation (Figure 63). Replace belt as required. Check the tension as follows:

1. Open hood.
2. Check tension by depressing belt midway between alternator and crankshaft pulleys with 22 lb. of force. Belt should deflect 7/16 in. If deflection is

incorrect, proceed to step 3. If correct, continue operation.



**Figure 63**

1. Alternator belt
2. Brace

3. Loosen bolt securing brace to engine and bolt securing alternator to brace.
4. Insert pry bar between alternator and engine and pry out on alternator.
5. When proper tension is achieved, tighten alternator and brace bolts to secure adjustment.
6. Tighten lock nut to secure adjustment.

## Hydraulic System Maintenance

### Changing the Hydraulic Fluid

Change hydraulic fluid after every 800 operating hours, in normal conditions. If fluid becomes contaminated, contact your local Toro distributor because the system must be flushed. Contaminated fluid looks milky or black when compared to clean oil.

1. Turn engine off and raise hood.
2. Remove drain plug from bottom of reservoir (Figure 64) and let hydraulic fluid flow into drain

pan. Install and tighten plug when hydraulic fluid stops draining.



**Figure 64**

1. Hydraulic reservoir

3. Fill reservoir with approximately 8.5 gallons of hydraulic fluid; refer to Checking the Hydraulic Fluid in Operation, page 21.

**Important:** Use only hydraulic fluids specified. Other fluids could cause system damage.

4. Install reservoir cap. Start engine and use all hydraulic controls to distribute hydraulic fluid throughout the system. Also check for leaks. Then stop the engine.
5. Check level of fluid and add enough to raise level to Full mark on dipstick. Do not overfill.

### Replacing the Hydraulic Filter

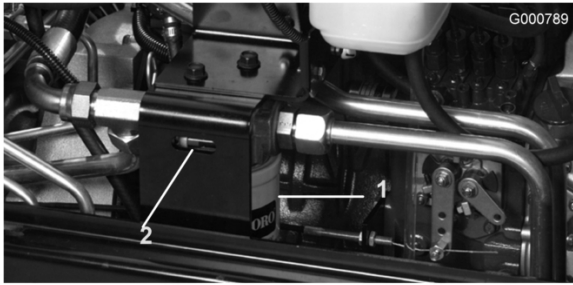
The hydraulic system filter head is equipped with a service interval indicator. With the engine running, view the indicator, it should be in the GREEN zone. When the indicator is in the RED zone, the filter element should be changed.

Use the Toro replacement filter (Part No. 94-2621).

**Important:** Use of any other filter may void the warranty on some components.

1. Position machine on a level surface, lower the cutting units, stop the engine, engage the parking brakes and remove key from ignition switch.

- Clean area around filter mounting area. Place drain pan under filter and remove filter (Figure 65).



**Figure 65**

- Hydraulic filter
- Service interval indicator

- Lubricate new filter gasket and fill the filter with hydraulic fluid.
- Ensure that the filter mounting area is clean. Screw filter on until gasket contacts mounting plate. Then tighten filter 1/2 turn.
- Start engine and let run for about two minutes to purge air from the system. Stop the engine and check for leaks.

## Checking the Hydraulic Lines and Hoses

Inspect hydraulic lines and hoses daily for leaks, kinked lines, loose mounting supports, wear, loose fittings, weather deterioration and chemical deterioration. Make all necessary repairs before operating.



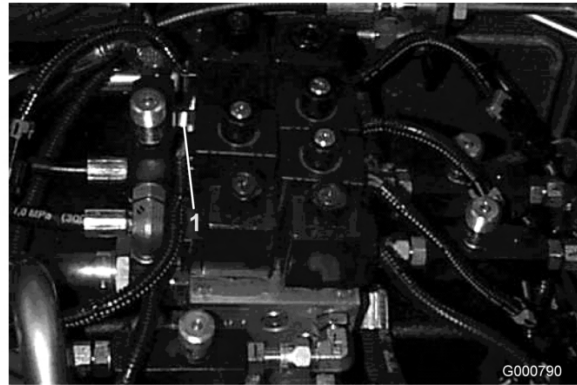
**Hydraulic fluid escaping under pressure can penetrate skin and cause injury.**

- Make sure all hydraulic fluid hoses and lines are in good condition and all hydraulic connections and fittings are tight before applying pressure to the hydraulic system.
- Keep your body and hands away from pin hole leaks or nozzles that eject high pressure hydraulic fluid.
- Use cardboard or paper to find hydraulic leaks.
- Safely relieve all pressure in the hydraulic system before performing any work on the hydraulic system.
- Get immediate medical help if fluid is injected into skin.

## Hydraulic System Test Ports

The test ports are used to test pressure in the hydraulic circuits. Contact your local Toro distributor for assistance.

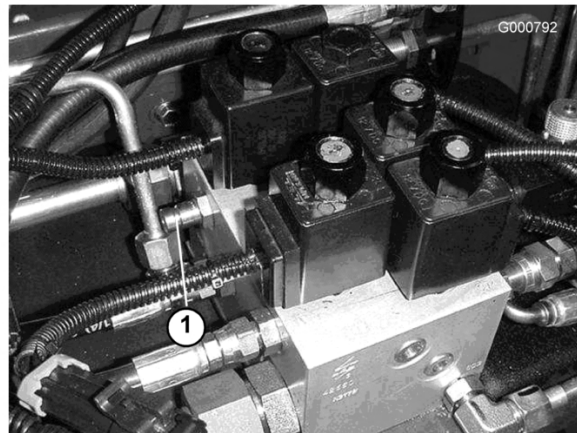
- Test Port A (Figure 66 and Figure 67) is used to assist in trouble shooting the hydraulic circuit for the lift cylinders.



**Figure 66**

Model 03808

- Test port A (Lift cylinders)

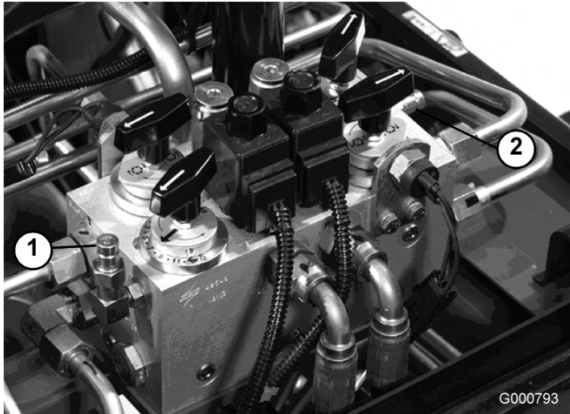


**Figure 67**

Models 03806 and 03807

- Test port A (Lift cylinders)
- Test Port B (Figure 68) is used to assist in trouble shooting the hydraulic circuit for the front cutting units.

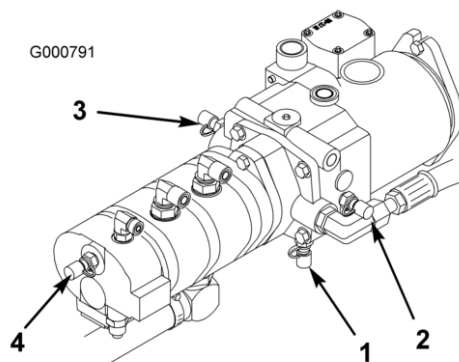
- Test Port C (Figure 68) is used to assist in trouble shooting the hydraulic circuit for the rear cutting units.



**Figure 68**

- Test port B (Front cutting units)
- Test port C (Rear cutting units)

- Test Port D is located on the bottom of the hydrostatic transmission (Figure 69) and is used to measure the charge pressure of the transmission.
- Test Port E is used to measure traction forward pressure (Figure 69).
- Test Port F is used to measure traction reverse pressure (Figure 69).
- Test Port G is used to measure steering circuit pressure (Figure 69).



**Figure 69**

- Test port D (Charge pressure)
- Test port E (Traction forward pressure)
- Test port F (Traction reverse pressure)
- Test port G (Steering circuit pressure)

## Cutting Unit Maintenance

### Backlapping

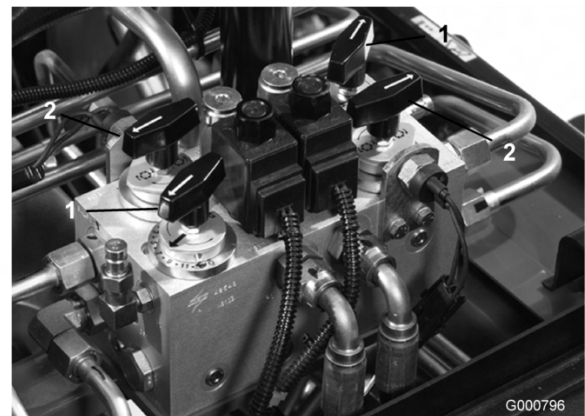


The reels may stall while backlapping and could restart suddenly. Contact with the reels during backlapping will cause personal injury.

- Never place hands or feet in the reel area while the engine is running.
- Never attempt to turn the reels by hand or foot or touch the reels while backlapping.
- Never change engine speed while backlapping. Only backlap at idle speed.
- Stop the engine and move the desired reel speed selector knob(s) one position closer to "13."

**Note:** When backlapping, the front units all operate together, and the rear units operate together.

- Position the machine on a level surface, lower the cutting units, stop the engine, engage the parking brake, and move the Enable/Disable switch to disable position.
- Unlock and raise the seat to expose controls.
- Locate the reel speed selector knobs and backlap knobs (Figure 70). Rotate the desired backlap knob(s) to the backlap position and the desired reel speed selector knob(s) to position 1.




**Figure 70**

- Reel speed selector knobs
- Backlap knobs

**Note:** Backlapping speed may be increased by moving the reel speed selector knob toward 13.

Each position will increase speed approximately 100 rpm. After changing selector, wait 30 seconds for the system to stabilize at the new speed.

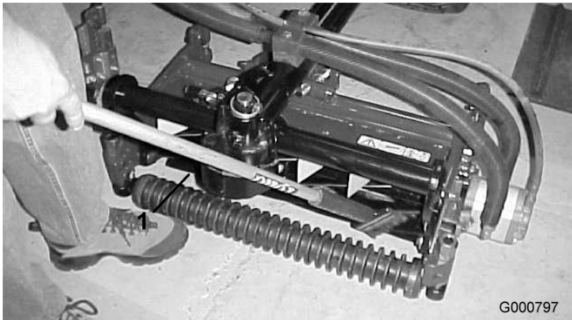
4. Make initial reel to bedknife adjustments appropriate for backlapping on all cutting units which are to be backlapped.
5. Start engine and run at idle speed.



**Contact with the reels or other moving parts can result in personal injury.**

- **Keep finger, hands, and clothing away from the reels and other moving parts.**
- **Never use a short handles brush to apply lapping compound.**

6. Select either front, rear, or both backlap knobs to determine which reels will be backlapped.
7. Move Enable/Disable switch to Enable position. Move Lower Mow/Lift control forward to start backlapping operation on designated reels.
8. Apply lapping compound with a long handle brush (Toro Part No. 29-9100). Never use a short handled brush (Figure 71).



**Figure 71**

1. Long handled brush

9. If reels stall or become erratic while backlapping, stop backlapping by moving the Lower Mow/Lift control lever rearward. Once the reels have stopped, move the desired reel speed selector knob(s) one position closer to 13. Resume backlapping by moving the Lower Mow/Lift control lever forward.
10. To make an adjustment to the cutting units while backlapping, turn reels Off by moving the Lower Mow/Raise lever rearward; move the Enable/Disable switch to Disable and turn the engine Off. After adjustments have been completed, repeat steps 5 through 9.

11. When the cutting unit is adequately sharpened, a burr will form on the front edge of the knife. Using a file, carefully remove the burr without dulling the cutting edge (Figure 72).



**Figure 72**

12. Repeat procedure for all cutting units to be backlapped.

When backlap operation has been completed, return the backlap knobs to the forward flow position, lower seat and wash all lapping compound off cutting units. Adjust cutting unit reel to bedknife as needed.

**Note:** If the backlap knobs are not returned to the forward flow position after backlapping, the cutting units will not raise or function properly.

## Adjust Turf Compensation Spring

Tractors are setup at the factory appropriately for most fairway mowing applications.

The following adjustments are available for fine-tuning of the machine to the application:

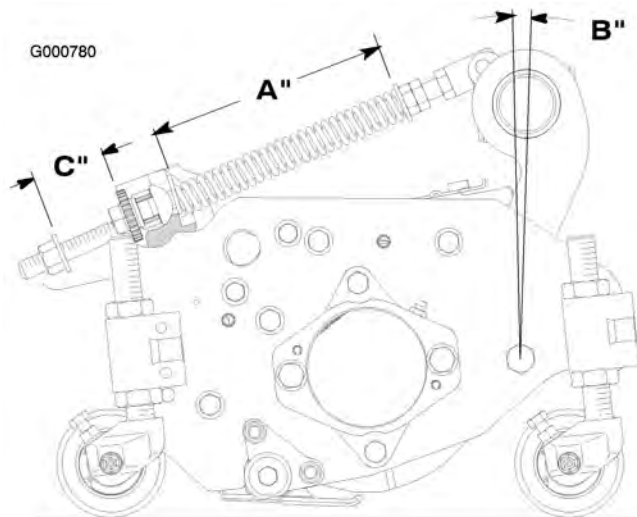
The Turf Compensation Spring (Figure 73), connecting carrier frame to cutting unit, controls the amount of

fore-aft rotation available, as well as the amount of ground clearance in transport and turn around.

The Turf Compensation Spring also transfers weight from the front to rear roller. This helps to reduce a wave pattern in the turf, also known as bobbing.

**Important:** Make spring adjustments with cutting unit mounted to traction unit and lowered to shop floor. Refer to Setup, page 12, for mounting instructions.

1. Tighten lock nut on rear of spring rod until the gap (C) between rear of spring bracket and front of washer is 1 in. (25 mm) (Figure 73).



**Figure 73**

2. Tighten hex nuts on front end of spring rod until the compressed length (A) of spring is 8 in. (203 mm) (Figure 73).

**Note:** When cutting rough or undulating turf, increase compressed length (A) of spring to 8-1/2 in. (216 mm) and gap (C) between rear of spring bracket and front of washer to 1-1/2 in. (38 mm) (Figure 73).

**Note:** As compressed spring length (A) decreases, weight transfer from front roller to rear roller increases and carrier frame/cutting unit rotation angle (B) decreases.

**Note:** As gap (C) between spring bracket and washer increases, cutting unit ground clearance decreases and carrier frame/cutting unit rotation angle (B) increases.

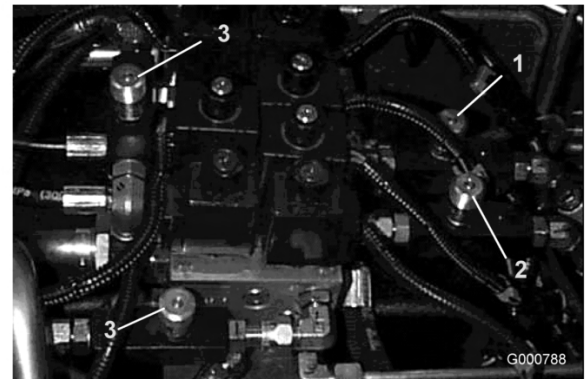
## Adjusting the Cutting Unit Lowering Rate

The cutting unit lift circuits are equipped with adjustable valves to ensure the cutting units lower at the desired rate. Adjust as follows:

Run traction unit until operating temperature is reached.

### Front Cutting Units

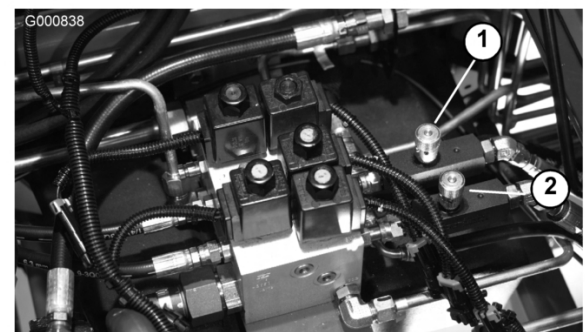
1. Locate valves under seat for adjusting front cutting units (Figure 74).



**Figure 74**

Model 03808

1. Adjustment valve for front center cutting unit
2. Adjustment valve for front outside cutting units
3. Adjustment valves for wing cutting units



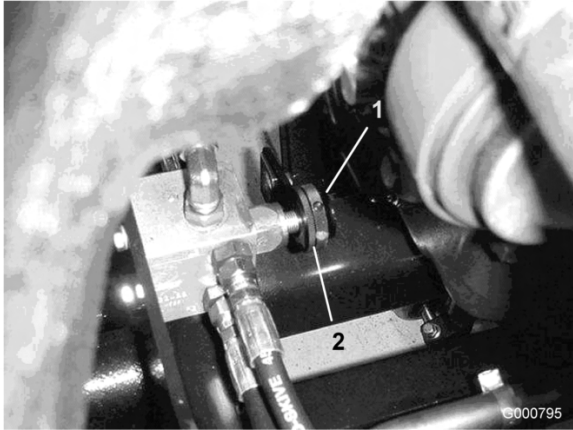
**Figure 75**

Models 03806 and 03807

1. Adjustment valves
2. Loosen set screws securing knob.
3. Rotate appropriate valve clockwise to slow down drop rate of cutting units.
4. Verify the lift rate adjustment by raising and lowering cutting units several times. Readjust as required. Tighten set screw securing adjustment.

## Rear Cutting Unit

5. Locate valve in front of rear axle for rear cutting units (Figure 76).



**Figure 76**

1. Adjustment valve for rear cutting unit
2. Locking pin

6. Loosen locking ring securing knob (Figure 76).
7. Rotate valve clockwise to slow down drop rate of rear cutting units.
8. Verify the lift rate adjustment by raising and lowering cutting units several times. Readjust as required. Tighten locking ring securing adjustment.

## Wing Cutting Units

9. Locate valves under seat for adjusting wing cutting units (Figure 74).
10. Loosen set screws securing knob.
11. Rotate appropriate valve clockwise to slow down drop rate of cutting units.
12. Verify the lift rate adjustment by raising and lowering cutting units several times. Readjust as required. Tighten set screw securing adjustment.

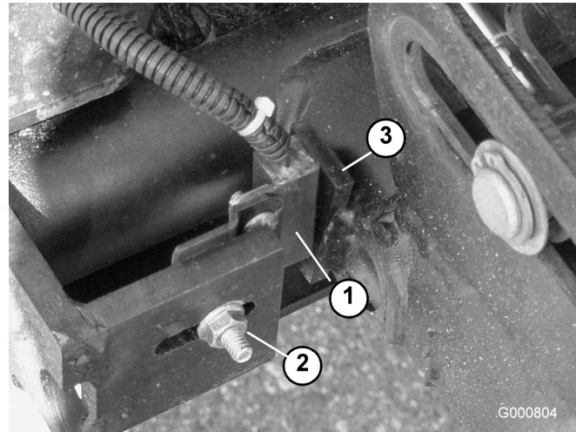
## Lifted Height of Outer Front Cutting Units (Enable Position)

The turnaround height of the front outer cutting units (#4 & #5) and rear (#6 & #7) cutting units may be increased to provide additional ground clearance on contoured fairways.

**Note:** The RM CONFIG time delay should not be changed from the original setting of 0 when using this method to adjust turn around height.

To increase/adjust the turn around height of the cutting units proceed as follows:

- Position machine on a level surface, lower the cutting units and stop the engine.
- Loosen the carriage bolt nut securing the lift arm switch bracket to the #4, 6 or 7 lift arms (Figure 77). #4 shown in figure.



**Figure 77**

1. Lift arm switch
2. Carriage bolt nut
3. Lift arm flag

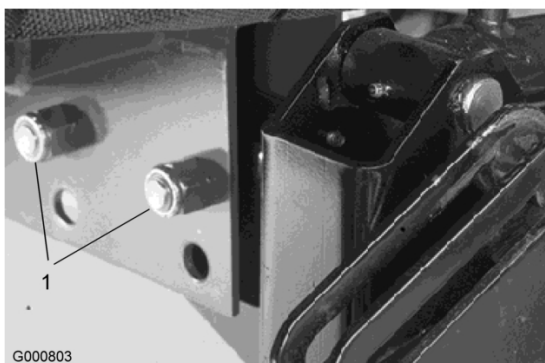
- Move the lift switch bracket up in the slot to the desired position.
- Set the distance between the lift arm switch and the flag on the lift arm to approximately .062 inches.
- Tighten carriage bolt nut.

## Adjusting the Travel of the Front Three Cutting Units

Additional downward travel of the front three cutting units may be desirable in highly contoured locations. If any of the front three cutting units lift off the ground when cresting a hill, the front carrier frame may be lowered by removing mounting bolts and repositioning frame in the bottom set of holes in the main frame (Figure 78). Contact your distributor for assistance.

**Note:** Moving the carrier frame down will decrease the amount of clearance between the cutting units and the ground in turnaround and transport positions

and may require adjusting the lift chain length on the cutting unit.



**Figure 78**

1. Carrier frame mounting bolts
-

# Storage

## Traction Unit

1. Thoroughly clean the traction unit, cutting units and the engine.
2. Check the tire pressure. Inflate all tires to 15-20 psi.
3. Check all fasteners for looseness; tighten as necessary.
4. Grease or oil all grease fittings and pivot points. Wipe up any excess lubricant.
5. Lightly sand and use touch-up paint on painted areas that are scratched, chipped, or rusted. Repair any dents in the metal body.
6. Service the battery and cables as follows:
  - A. Remove the battery terminals from the battery posts.
  - B. Clean the battery, terminals, and posts with a wire brush and baking soda solution.
  - C. Coat the cable terminals and battery posts with Grafo 112X skin-over grease (Toro Part No. 505-47) or petroleum jelly to prevent corrosion.
  - D. Slowly recharge the battery every 60 days for 24 hours to prevent lead sulfation of the battery.



**Charging the battery produces gasses that can explode.**

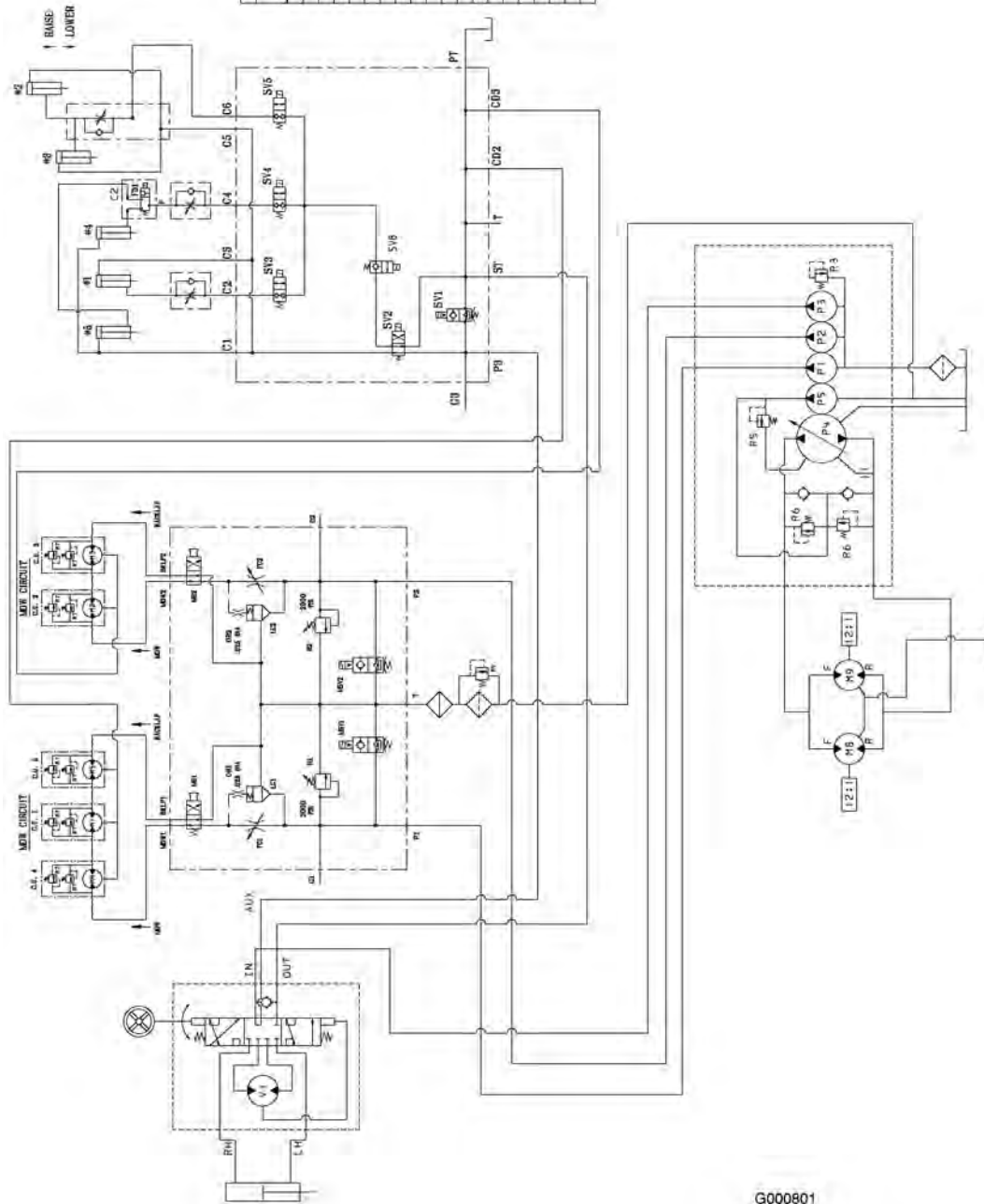
**Never smoke near the battery and keep sparks and flames away from battery.**

9. Seal the air cleaner inlet and the exhaust outlet with weatherproof tape.
10. Check anti freeze protection and add a 50/50 solution of water and anti freeze as needed for expected minimum temperature in your area.

## Engine

1. Drain the engine oil from the oil pan and replace the drain plug.
2. Remove and discard the oil filter. Install a new oil filter.
3. Refill oil pan with 7.5 qts. (7 l) of SAE10W-30 CD, CE, CF, CF-4, or CG-4 motor oil.
4. Start the engine and run at idle speed for approximately two minutes.
5. Stop the engine.
6. Flush the fuel tank with fresh, clean diesel fuel.
7. Secure all fuel system fittings.
8. Thoroughly clean and service the air cleaner assembly.





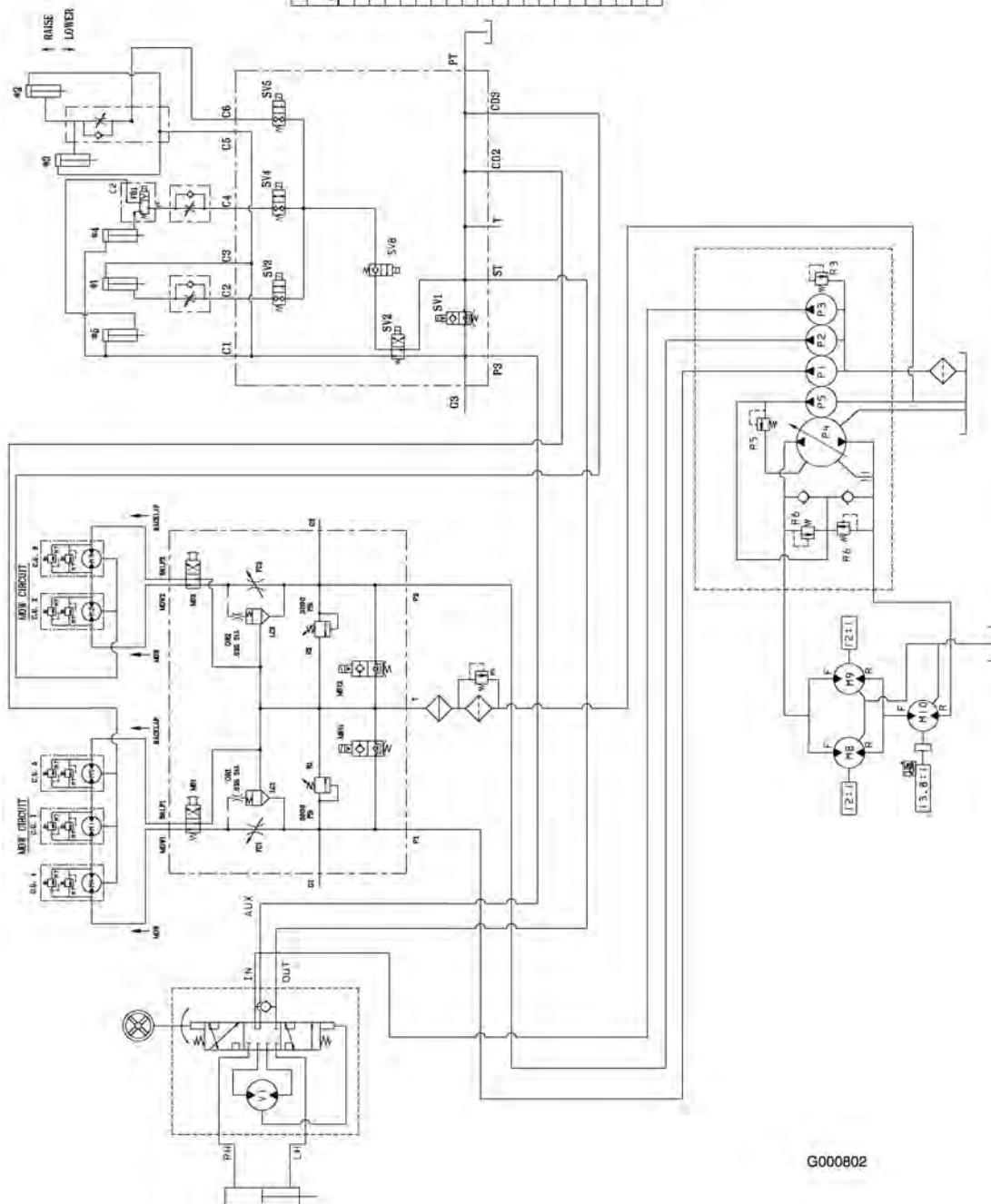
DISPLACEMENT, FLOW RATE, AND PRESSURE CHART

COMPONENT	DISPLACEMENT (in <sup>3</sup> /Rev. @ 3000 RPM)	PRESSURE (Psi @ 3000 RPM)	FLOW RATE * (GPM @ 3000 RPM)
P1	.66	10.8	8.4
P2	.66	10.8	8.4
P3	.40	6.6	5.1
P4	2.48	40.6	31.6
P5	.84	13.8	10.7
M1	1.16	19	
M2	1.16	19	
M3	1.16	19	
M4	1.16	19	
M5	1.16	19	
M6	2.01	32.9	
M7	2.01	32.9	
M8	2.01	32.9	
M9	2.01	32.9	
M10	2.01	32.9	
M11	6.11	100	
R1			3000
R2			2000
R3			1500
R4			50
R5			250
R6			4000
R7			1500

\* FLOW RATE CALCULATED AT 3000 RPM AND 90% EFFICIENCY.

G000801

Hydraulic Schematic, Model 03806 (Rev. -)



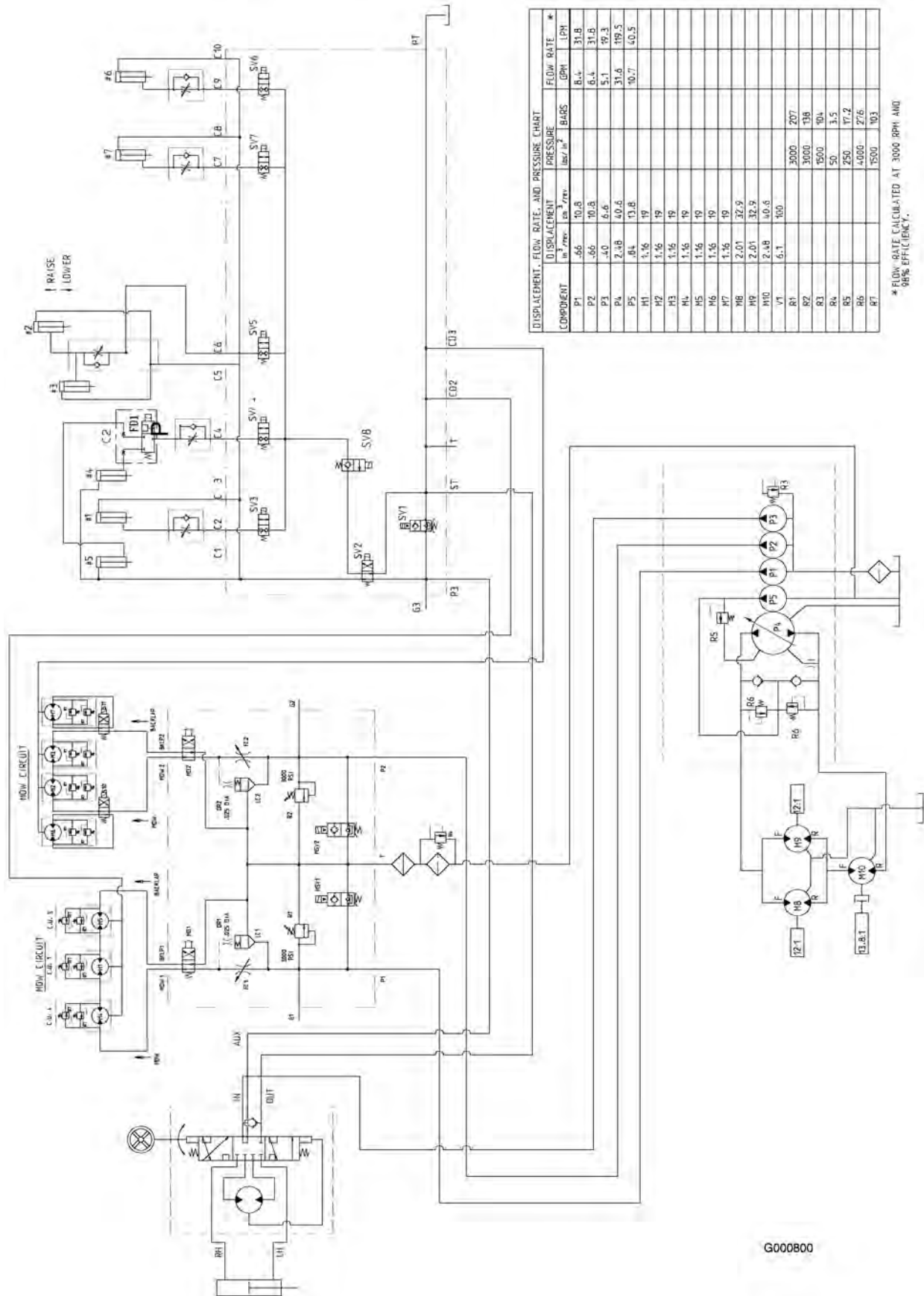
DISPLACEMENT, FLOW RATE, AND PRESSURE CHART

COMPONENT	DISPLACEMENT cm <sup>3</sup> /Rev.	DISPLACEMENT in <sup>3</sup> /Rev.	PRESSURE BAR	PRESSURE PSI	FLOW RATE LPM	FLOW RATE GPM
P1	6.6	10.8			8.4	31.8
P2	6.6	10.8			8.4	31.8
P3	4.0	6.6			5.1	19.3
P4	2.48	40.6			31.6	119.5
P5	.84	3.8			10.7	40.5
M1	1.16	19				
M2	1.16	19				
M3	1.16	19				
M4	1.16	19				
M5	1.16	19				
M6	2.01	32.9				
M7	2.01	32.9				
M8	2.01	32.9				
M9	2.01	32.9				
M10	2.48	40.6				
V1	6.1	100				
R1			3000	207		
R2			2000	138		
R3			1500	108		
R4			50	3.5		
R5			250	17.2		
R6			4000	276		
R7			1500	103		

\* FLOW RATE CALCULATED AT 3000 RPM AND 98% EFFICIENCY.

G000802

Hydraulic Schematic, Model 03807 (Rev. -)



Hydraulic Schematic, Model 03808 (Rev. -)





## The Toro General Commercial Products Warranty

A Two-Year Limited Warranty

### Conditions and Products Covered

The Toro Company and its affiliate, Toro Warranty Company, pursuant to an agreement between them, jointly warrant your Toro Commercial Product ("Product") to be free from defects in materials or workmanship for two years or 1500 operational hours\*, whichever occurs first. Where a warrantable condition exists, we will repair the Product at no cost to you including diagnosis, labor, parts, and transportation. This warranty begins on the date the Product is delivered to the original retail purchaser.

\* Product equipped with hour meter

### Instructions for Obtaining Warranty Service

You are responsible for notifying the Commercial Products Distributor or Authorized Commercial Products Dealer from whom you purchased the Product as soon as you believe a warrantable condition exists.

If you need help locating a Commercial Products Distributor or Authorized Dealer, or if you have questions regarding your warranty rights or responsibilities, you may contact us at:

Toro Commercial Products Service Department  
Toro Warranty Company  
8111 Lyndale Avenue South  
Bloomington, MN 55420-1196  
952-888-8801 or 800-982-2740  
E-mail: commercial.service@toro.com

### Owner Responsibilities

As the Product owner, you are responsible for required maintenance and adjustments stated in your operator's manual. Failure to perform required maintenance and adjustments can be grounds for disallowing a warranty claim.

### Items and Conditions Not Covered

Not all product failures or malfunctions that occur during the warranty period are defects in materials or workmanship. This express warranty does not cover the following:

- Product failures which result from the use of non-Toro replacement parts, or from installation and use of add-on, modified, or unapproved accessories
- Product failures which result from failure to perform required maintenance and/or adjustments
- Product failures which result from operating the Product in an abusive, negligent or reckless manner
- Parts subject to consumption through use unless found to be defective. Examples of parts which are consumed, or used up, during normal Product operation include, but are not limited to, blades, reels, bedknives, tines, spark plugs, castor wheels, tires, filters, belts, and certain sprayer components such as diaphragms, nozzles, and check valves, etc.

### Countries Other than the United States or Canada

Customers who have purchased Toro products exported from the United States or Canada should contact their Toro Distributor (Dealer) to obtain guarantee policies for your country, province, or state. If for any reason you are dissatisfied with your Distributor's service or have difficulty obtaining guarantee information, contact the Toro importer. If all other remedies fail, you may contact us at Toro Warranty Company.

- Failures caused by outside influence. Items considered to be outside influence include, but are not limited to, weather, storage practices, contamination, use of unapproved coolants, lubricants, additives, or chemicals, etc.
- Normal "wear and tear" items. Normal "wear and tear" includes, but is not limited to, damage to seats due to wear or abrasion, worn painted surfaces, scratched decals or windows, etc.

### Parts

Parts scheduled for replacement as required maintenance are warranted for the period of time up to the scheduled replacement time for that part.

Parts replaced under this warranty become the property of Toro. Toro will make the final decision whether to repair any existing part or assembly or replace it. Toro may use factory remanufactured parts rather than new parts for some warranty repairs.

### General Conditions

Repair by an Authorized Toro Distributor or Dealer is your sole remedy under this warranty.

**Neither The Toro Company nor Toro Warranty Company is liable for indirect, incidental or consequential damages in connection with the use of the Toro Products covered by this warranty, including any cost or expense of providing substitute equipment or service during reasonable periods of malfunction or non-use pending completion of repairs under this warranty. Except for the Emissions warranty referenced below, if applicable, there is no other express warranty. All implied warranties of merchantability and fitness for use are limited to the duration of this express warranty.**

Some states do not allow exclusions of incidental or consequential damages, or limitations on how long an implied warranty lasts, so the above exclusions and limitations may not apply to you.

This warranty gives you specific legal rights, and you may also have other rights which vary from state to state.

Note regarding engine warranty: The Emissions Control System on your Product may be covered by a separate warranty meeting requirements established by the U.S. Environmental Protection Agency (EPA) and/or the California Air Resources Board (CARB). The hour limitations set forth above do not apply to the Emissions Control System Warranty. Refer to the Engine Emission Control Warranty Statement printed in your operator's manual or contained in the engine manufacturer's documentation for details.