



# Brake and Signal Light Kit

## e2050 Workman® Series

Part No. 107-8020

Form No. 3353-358 Rev B

### Installation Instructions

**Important** Before installing this kit, you must have 12V Converter Kit, Model 07286 installed on the vehicle.

## Loose Parts

| Description   | Qty. | Use                                      |
|---|------|--|
| Signal controller   | 1    | Installing the signal controller         |
| Grommet   | 1    |  |
| Signal light  | 2    | Installing the signal lights             |
| Pan head screw, 1/4 x 1 inch                                | 4    |  |
| Flat washer   | 4    |  |
| Locknut   | 4    |  |
| Signal harness  | 1    |  |
| Brake switch  | 1    | Install the brake switch                 |
| Bolt, #6  | 2    |  |
| Locknut, #6   | 2    |  |
| Flasher   | 1    | Install the dash harness                 |
| Timer   | 1    |  |
| Bolt, 1/4 x 1-3/8 inch                                      | 1    |  |
| Bolt, 1/4 x 3/4 inch  | 1    |  |
| Locknut, 1/4 inch   | 2    |  |
| R-clamp, large  | 1    |  |
| Wire tie  | 2    |  |
| Screw #10, thread cutting                                   | 1    |  |
| Tail light  | 2    | Install the tail lights and rear harness |
| Silicone sealant (not supplied, purchase before installing) | 0    |  |
| Rear harness  | 1    |  |
| R-clamp, small  | 3    |  |
| Screw, 1/4 x 0.82 inch                                      | 3    |  |
| Wire tie  | 2    |  |
| Front reflector   | 2    | Install the reflectors                   |
| Bolt, #10   | 2    |  |
| Locknut, #10  | 2    |  |
| Rear reflector  | 2    |  |
| Screw, #10  | 4    |  |

# Preparing the Vehicle

1. Position the vehicle on a level surface, engage the parking brake and rotate the On/Off key to the Off position.

⚠ **Caution** ⚠

**If you leave the key in the On/Off switch, someone could accidentally turn On the vehicle and seriously injure you or other bystanders.**

**Remove the key from the On/Off switch before performing any maintenance.**

2. Remove the hood from the vehicle by removing the bumper, 2 screws on top of the hood, the 2 bolts on each fender, and the 4 bolts from the bottom of the hood.
3. Remove the seat base.

# Installing the Signal Controller

1. On the top edge of the dash, mark the location of the signal controller wire harness as shown in Figure 1.
2. Drill a hole (3/4 inch) and slot (3/8 inch wide) in the dash (Fig. 1).
3. Slit one side of the grommet and slide it over the signal controller wire harness.

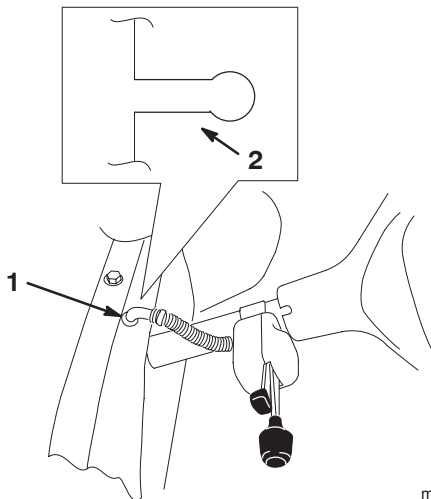

**Figure 1**

1. Harness location
2. Hole & slot

4. Attach the signal controller to the steering column as follows:

A. Insert the screws into the anchors.

- B. Insert the assembled anchor screws into the slots in the signal controller. Do not tighten.
- C. Cut the strap included with the signal controller to 4-1/2 inch (114 mm) long.
- D. Insert one end of the strap through the clip of the signal controller and bend the strap 1 inch (25 mm) from the end. Catch the clip under the anchor on the controller (Fig. 2).

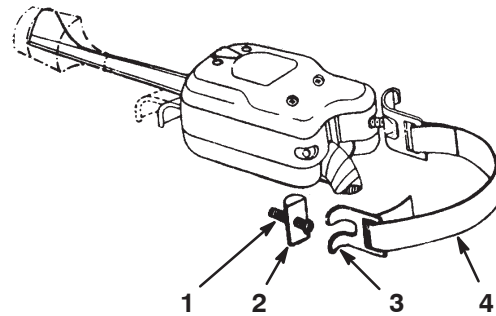

**Figure 2**

1. Screw
2. Anchor
3. Clip
4. Strap

- E. Hold the controller against the steering column so that the strap is approximately 1/4 inch from the foam on the steering column (Fig. 3). Bend the strap around the column. Insert the other end of the strap through the second clip and bend the strap 1 inch (25 mm) from the end. Catch the clip under the anchor on the controller.

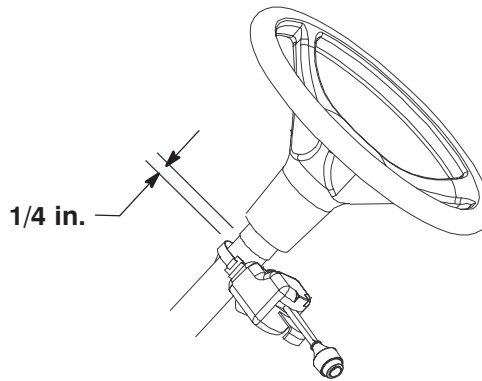

**Figure 3**

- F. Tighten the anchor screws equally until the signal controller is clamped firmly to the steering column.
5. Slide the wire harness through the drilled slot and into the hole. Seat the grommet in the hole.
  6. Unplug the six terminal cap from the 12V Converter harness and plug in the signal control harness.

## Installing the Signal Lights

1. Using the rubber seal on the signal lights as a template, locate, mark and drill 2 holes (9/32 inch dia.) for the screws and a hole (3/4 inch dia.) for the wires in each side of the hood in the approximate locations shown in Figures 4.

**Note:** On Workman vehicles, locate the signal lights as far forward as possible where the lights are still flush with the hood.

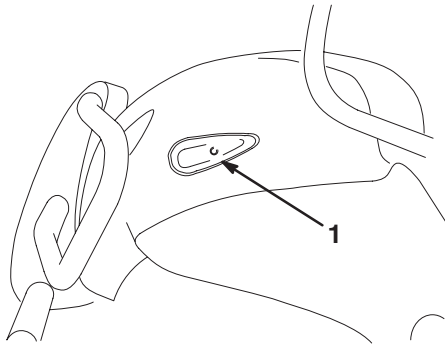

**Figure 4**  
Workman 1100 and 2100

1. Signal light

2. Remove the lens from the signal lights.
3. Remove the bulb and attach each signal light to the hood with 2 screws, washers, and locknuts.
4. Install the bulb and attach the lens.
5. Plug the short end of the signal harness into the left signal light. Plug the long end of the harness into the right signal light.
6. Secure the signal harness to the vehicle headlight harness with 2 wire ties.
7. Plug the remaining end of the signal harness into the open plug in the 12V converter harness marked "To front turn signal harness".

## Installing the Brake Switch

1. Install brake switch to pedal assembly using #6 bolts and lock nuts (Fig. 2).

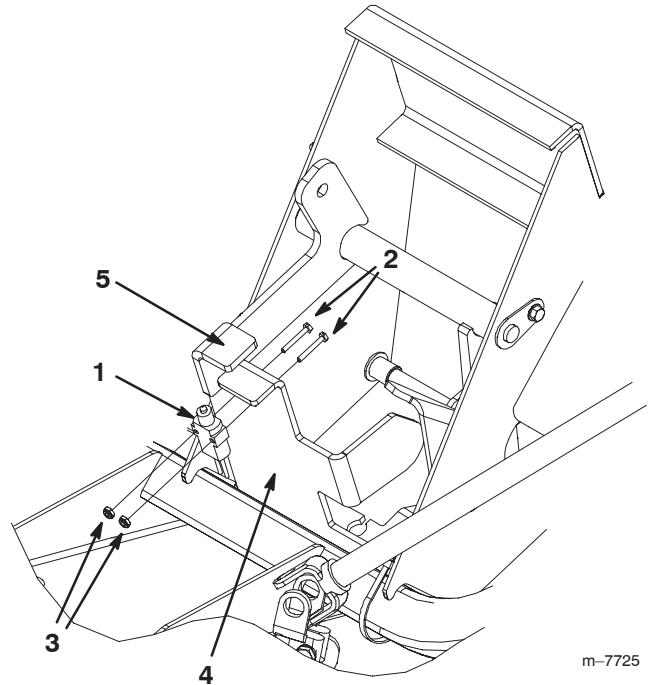

**Figure 5**

1. Brake switch
2. Bolts, #6
3. Lock nuts, #6
4. Pedal assembly
5. Brake pedal arm

2. Make sure brake pedal arm is aligned and makes contact with brake switch button when pedal is released.
3. Check the depth of brake switch button while of brake switch is engaged. Switch should be adjusted to allow the button to be depressed but not bottomed out when brake pedal is released and button should be extended with clearance when brake is applied.
4. Verify the alignment and actuation of switch by applying and releasing brake.

## Installing the Flasher, Relay, and Timer

1. Connect the flasher to the 12V Converter dash harness (Fig. 6).

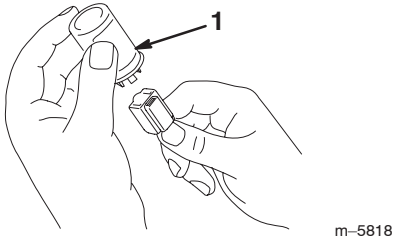

**Figure 6**

1. Flasher

2. Connect the timer to the 12V Converter harness as illustrated in Figure 7.

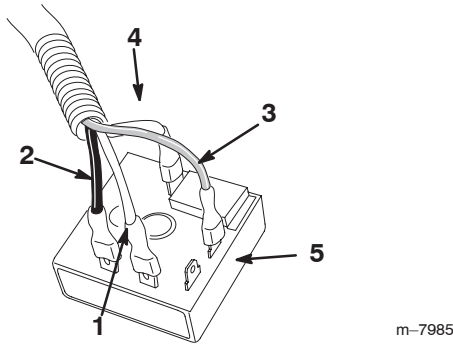

**Figure 7**

1. White wire to terminal 1
2. Black wire to terminal 2
3. White wire to terminal C
4. Gray and black wire to N.O. terminal
5. Timer

3. Connect the timer to the front side (under the hood) of the dash plate using a bolt (1/4 x 1-3/8 inch) and locknut (1/4 inch) in the location illustrated in Figures 8 and 9.

4. Connect the flasher to the back side (under the dash) of the dash plate using a large R-clamp, a bolt (1/4 x 3/4 inch), and a locknut (1/4 inch) in the location illustrated in Figures 8 and 9.

5. Mount the relay from the signal controller to the dash plate using a #10, thread cutting screw (Fig. 9).

**Note:** The white wire with the eyelet is not used; cover with electrical tape and secure it to the harness with a wire tie.

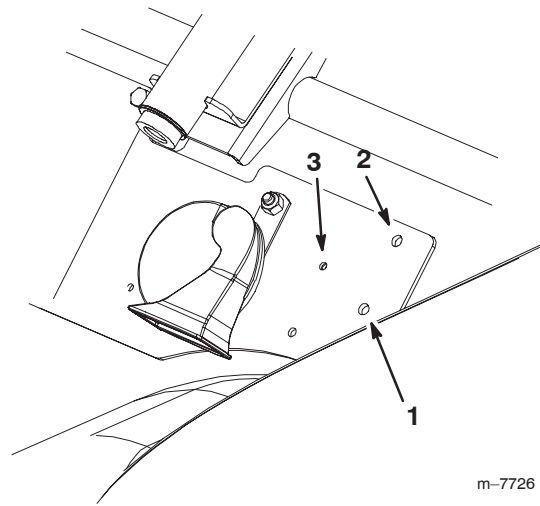

**Figure 8**

Viewed from the Front of the Vehicle

1. Hole for the timer
2. Hole for the flasher
3. Hole for the signal controller relay

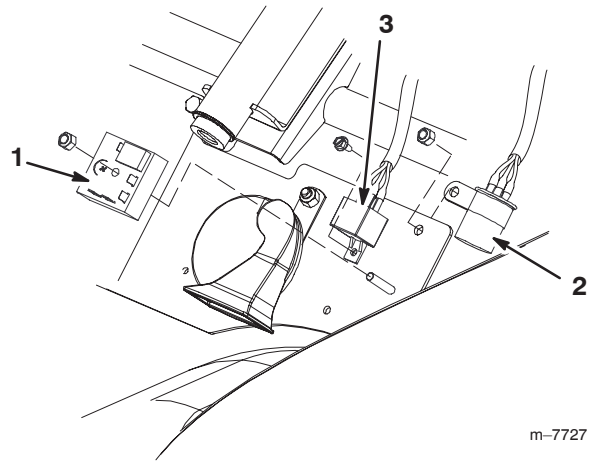

**Figure 9**

Viewed from the Front of the Vehicle

1. Timer
2. Flasher
3. Signal controller relay

# Installing the Taillights

1. Drill 2 holes (1/4 inch dia.) in each taillight location in the back of the bed. The location of these holes is molded into the box.
2. Drill a hole (1-1/2 inch dia.) in each taillight location in the back of the bed as shown in Figure 10.

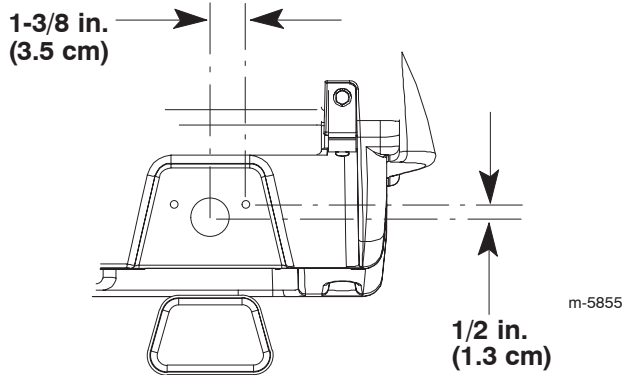

**Figure 10**

3. Raise the bed.
4. Through the right side, inside surface of the box toward the rear, drill a hole (1-1/2 inch dia.) through the inner wall of the box in the location shown in Figure 11.



**Figure 11**

1. Right hole

5. Through the left side, inside surface of the box toward the rear, drill a hole (1-1/2 inch dia.) through the inner wall of the box in the location shown in Figure 12.



**Figure 12**

1. Left hole

6. Route the harnesses on the back of the taillights through the holes you drilled in step 1 and through the holes you drilled in step 4 and 5.

**Note:** To ease installation, use a stiff wire hook to pull the wire harnesses through the holes.

7. Apply a bead of silicone sealant around the back of each taillight about 1/2 inch from the edge and install each taillight onto the bed.
8. Route the rear wire harness from the left taillight harness, across the back, and over to the right side, securing it with 3 R-clamps and 3 screws (1/4 x 0.82 inch) (Fig. 13).

**Note:** You will need to drill 3 holes (13/64 inch dia.) in the bed in which to install the R-clamps.

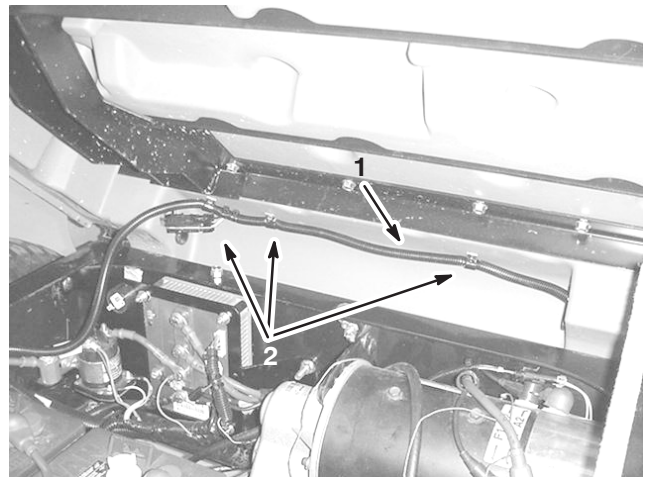

**Figure 13**

1. Rear harness
2. R-clamps

9. Route the harness around the battery and follow the main harness through the frame to the front of the vehicle.
10. Secure the harness to the frame with wire ties.

## Connecting the 12V Converter Harness to the Brake Switch and Lights

1. Locate and disconnect the connector marked “HEAD LIGHT SECOND POLE” on the main vehicle harness.
2. Locate and remove the cap from the connector on the 12V converter harness marked “TO LIGHT SWITCH PLUG”.
3. Plug the “TO LIGHT SWITCH PLUG” connector into the “HEAD LIGHT SECOND POLE” connector on the main vehicle harness.
4. Plug the remaining cap into the now open connector on the main vehicle harness.
5. Plug the connector marked, “BRAKE SWITCH” on the 12V Converter harness to the connector on the brake switch.
6. Plug the Connector marked, “TO TAIL LIGHT HARNESS” on the 12V Converter harness into the open plug on the rear harness routed through the frame previously.
7. Instal the hood and seat base.

## Installing the Reflectors

1. Drill a hole (#10 drill bit) on each side of the hood in the location shown in Figure 14.



**Figure 14**

1. Front reflector

2. Install the front reflectors, using 2 bolts (#10) and 2 locknuts (#10) (Fig. 14).
3. Drill 2 holes (13/64 inch dia.) on each side of the box in the location shown in Figure 15, using the reflector as a template to mark the hole locations.



**Figure 15**

1. Rear reflector

4. Install the rear reflectors, using 4 screws (#10) (Fig. 15).
  - Locate the plug marked, “HEAD LIGHT SECOND POLE” on the main vehicle harness. Remove the cap and discard. Plug this connector into the connector on the 12V Converter harness marked, “TO LIGHT SWITCH PLUG.”

# Schematic

