

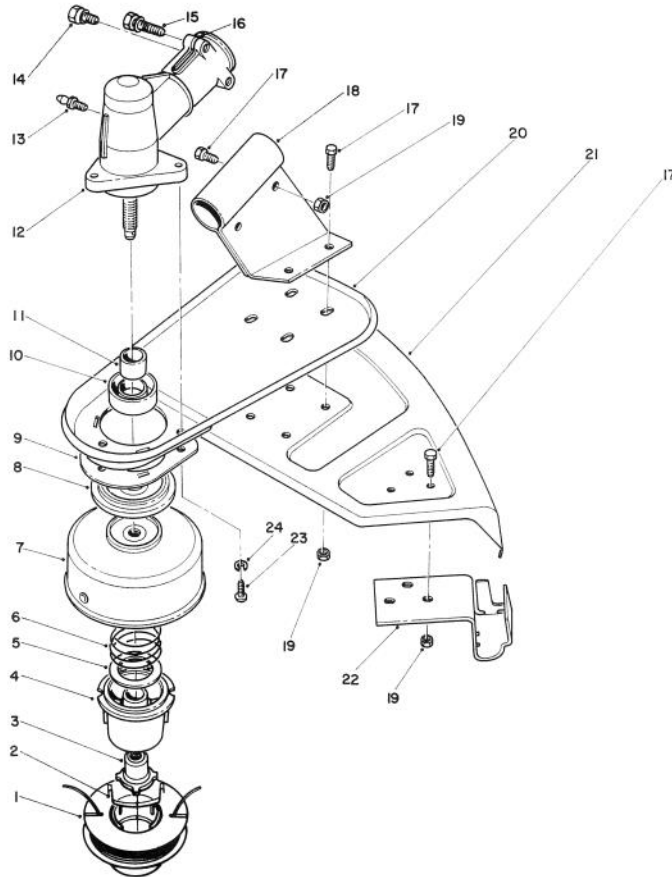

MODEL NO. 51650-8000001
THRU 9000001 & UP

**PARTS
CATALOG**

TC 3100 GAS TRIMMER



C-0210-89

TRIMMER HEAD & GEAR BOX ASSEMBLY

Ref. No.	Part No.	Description	No. Used
1	46-2680	Prewound Spool	1
2	33-8940	Saddle — Spool Cap	1
3	61-4560	Driver L.H.	1
4	33-6230	Core — Spool	1
5	3256-42	Washer	1
6	33-6460	Spring — Compression	1
7	46-2650	Drum Assembly w/Eyelets	1
8	48-2080	Cap — Dust	1
9	57-5540	Guard — Grass Wrap	1
10	48-2090	Seal — Oil	1
11	48-2100	Sleeve — Spline	1
12	52-5710	Gear Box Assembly (Incl. Ref. #10, 11, & 13-16)	1
13	53-7410	Fitting — Grease	1

Ref. No.	Part No.	Description	No. Used
14	48-2150	Hex Hd. Machine Screw	1
15	48-2130	Hex Hd. Machine Screw	2
16	48-2140	Washer	2
17	32105-8	Hex Hd. Machine Screw	9
18	47-2760	Bracket — Shield	1
19	3296-2	Locknut	9
20	47-2800	Support — Shield	1
21	61-4571	Shield — Grass	1
22	61-4540	Bracket & Knife Blade Ass'y	1
23	57-5550	Screw — Guard	3
24	55-8050	Lockwasher	3
*	46-6740	Head Assembly (Incl. Ref. #1-7)	1

*Not Illustrated

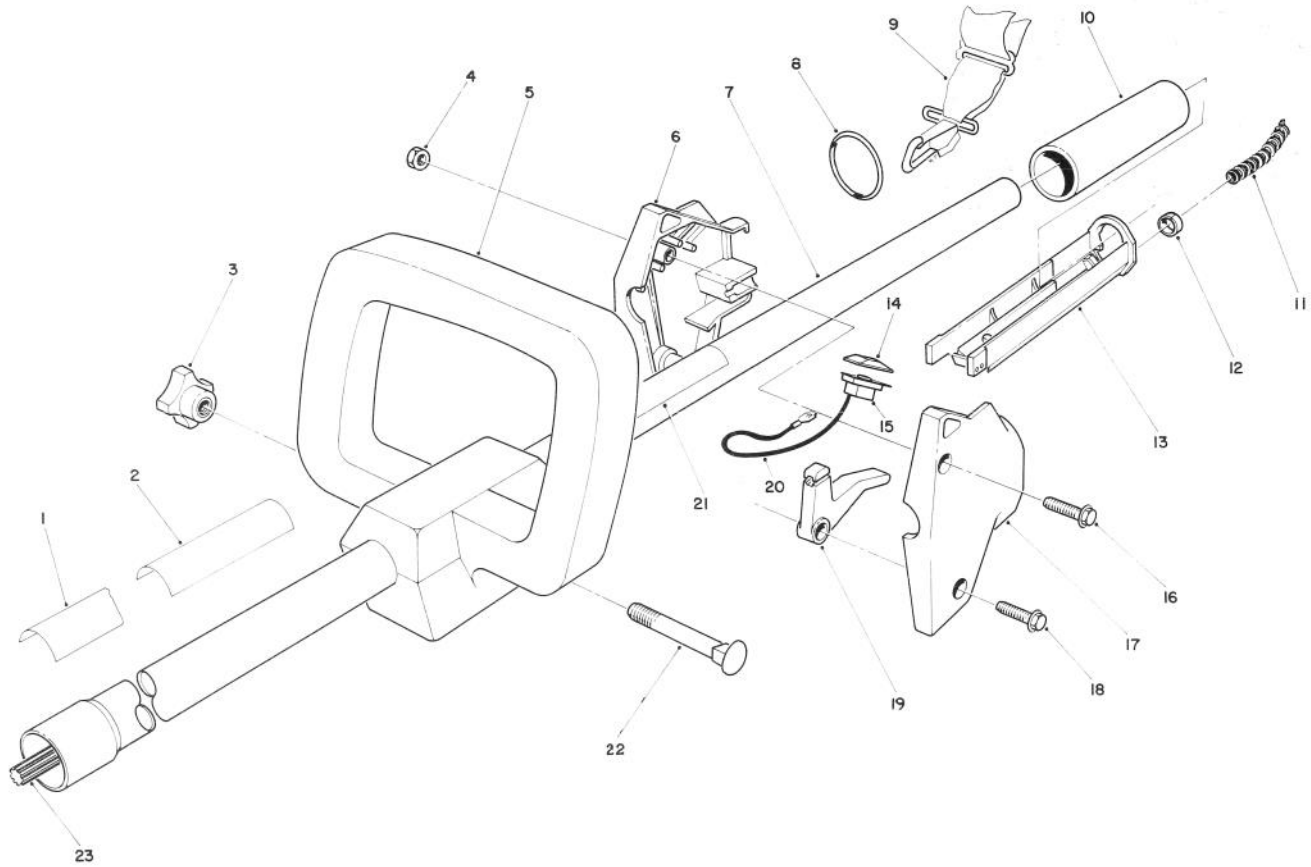

C-0211-89

HANDLE ASSEMBLY

Ref. No.	Part No.	Description	No. Used
1	61-4480	Decal — TC 3100	1
2	65-3090	Decal — Instruction	1
3	42-5890	Knob — Loop Handle	1
4	3296-12	Locknut	2
5	42-5550	Handle	1
6	53-7250	Housing — R.H.	1
7	61-4390	Tube Assembly	1
8	44-7540	Ring — Harness	1
9	57-5430	Harness — Shoulder	1
10	53-7120	Grip	1
11	55-8411	Cover — Cable	1
12	2412-48	Clip	2

Ref. No.	Part No.	Description	No. Used
13	53-7290	Trough	1
14	218-507	Cap — Switch	1
15	42-6000	Switch	1
16	32105-12	Hex Washer Hd. Screw	1
17	53-7260	Housing — L.H.	1
18	32105-13	Hex Washer Hd. Screw	1
19	53-7270	Lever — Throttle	1
20	53-7370	Wire Assembly	2
21	65-3100	Decal — Danger	1
22	3-7253	Carriage Bolt	1
23	53-7211	Spline Shaft — Drive	1

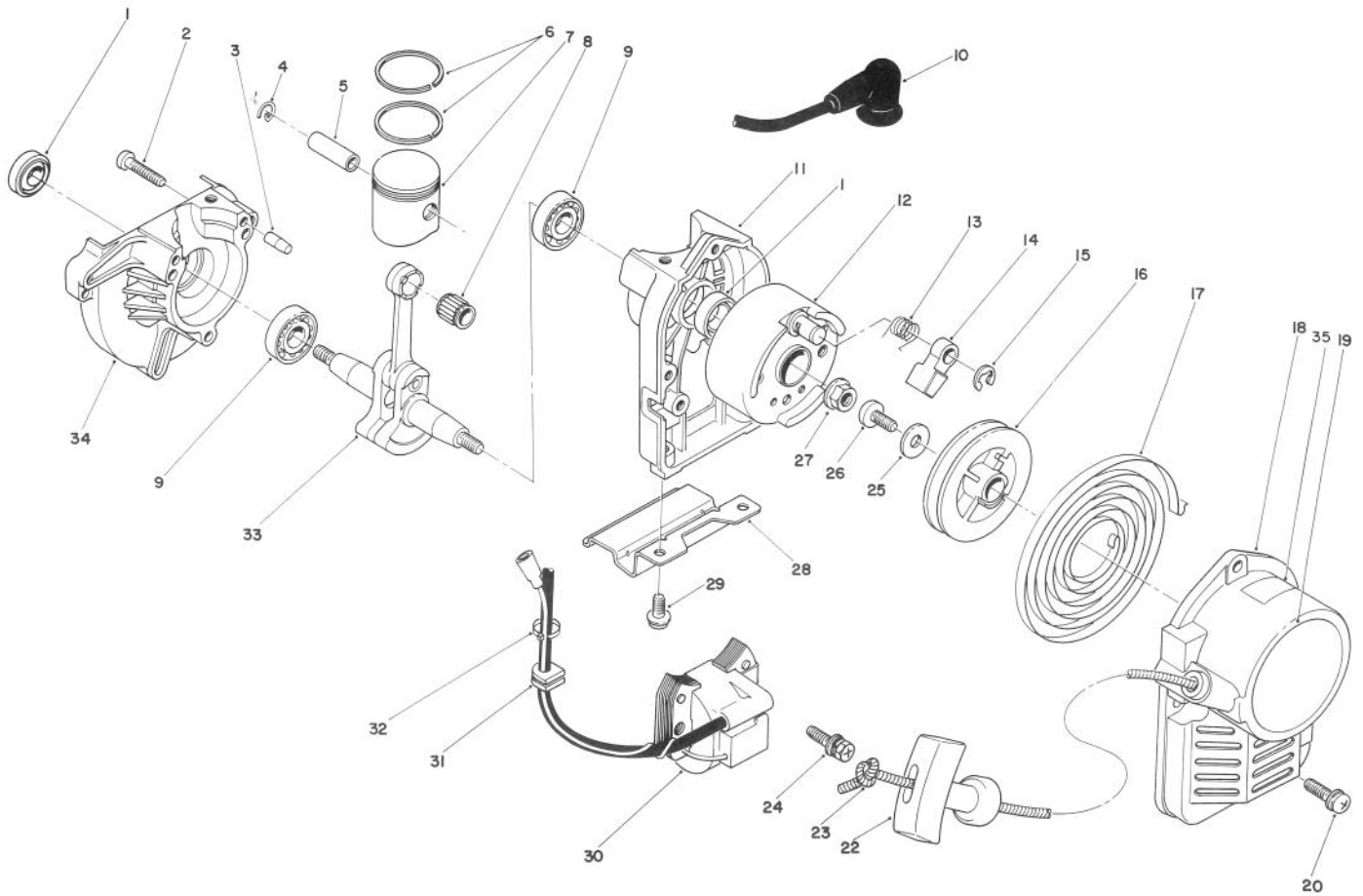

C-0212-89

RECOIL & CRANKSHAFT ASSEMBLY

Ref. No.	Part No.	Description	No. Used
1	54-4380	Oil Seal	2
2	54-4330	Screw	3
3	60-7590	Pin, Dowel	2
4	54-5920	Clip, Piston Pin	2
5	54-5910	Pin, Piston	1
6	54-5940	Ring, Piston	2
7	54-5900	Piston Assembly (Incl. Ref. #5)	1
8	54-5930	Bearing, Needle	1
9	54-4360	Bearing, Ball	2
10	54-4730	Cap, Plug	1
11	60-7600	Case, Starter Side	1
12	60-7800	Rotor	1
13	60-7810	Spring, Return	1
14	60-7820	Ratchet	1
15	60-7830	Snap Ring	1
16	60-8230	Reel	1
17	54-5420	Spring, Spiral	1

Ref. No.	Part No.	Description	No. Used
18	65-4480	Case, Starter	1
19	57-5570	Decal — Toro	1
20	60-7930	Screw & Washer	3
22	54-5440	Knob — Starter	1
23	54-6370	Rope, Starter	1
24	60-7610	Bolt & Washer	2
25	65-4470	Washer	1
26	60-8220	Screw	1
27	60-7770	Nut, Conical Spring	1
28	60-7660	Stand	1
29	60-7620	Screw & Washer	2
30	60-7860	Coil, Ignition	1
31	60-7840	Grommet	1
32	54-5990	Band	1
33	60-7790	Crankshaft Assembly	1
34	60-7650	Case, Drive Side	1
35	65-2690	Decal — Hot	2
*	65-4460	Recoil Assembly (Incl. Ref. #16-18, 22-23 & 25-26)	1

*Not Illustrated

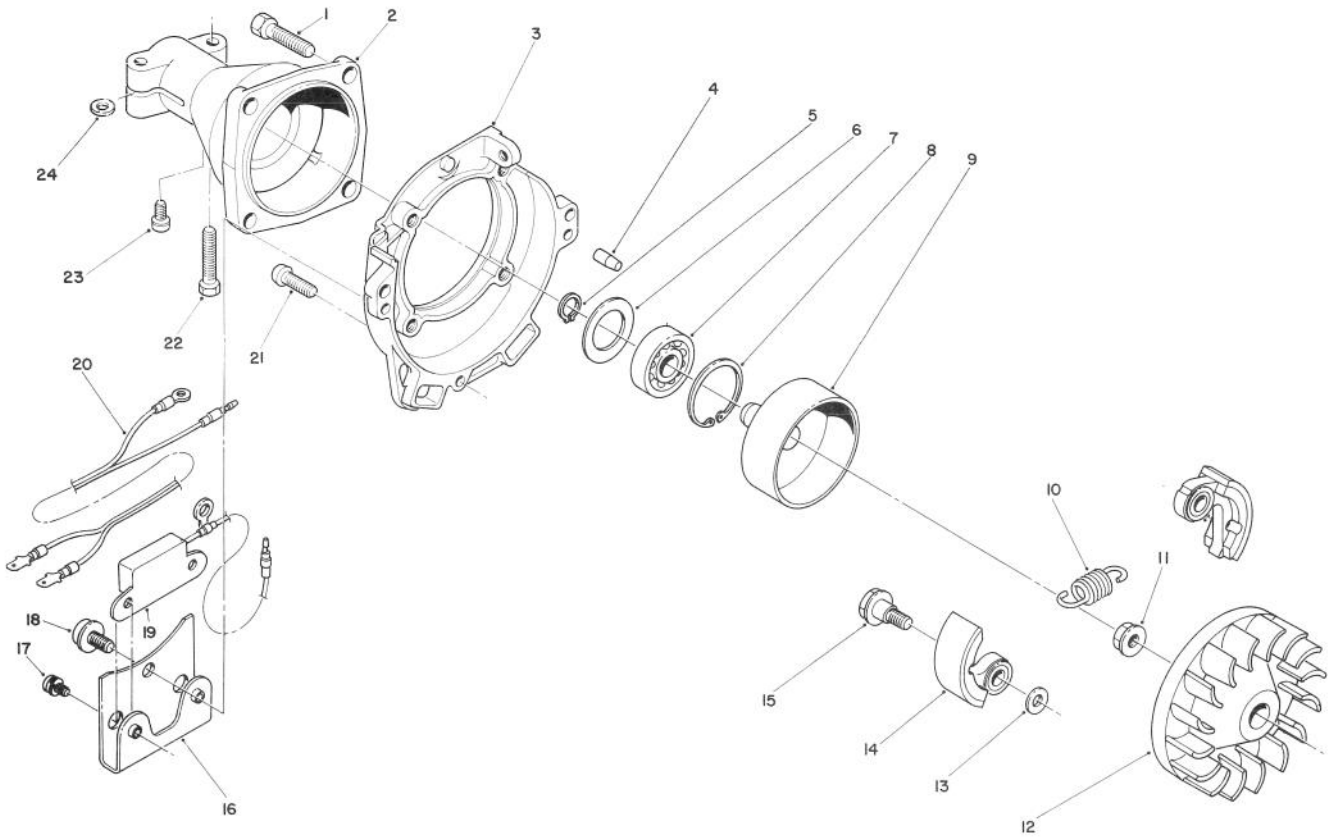

C-0213-89

CLUTCH CASE & FAN ASSEMBLY

Ref. No.	Part No.	Description	No. Used
1	54-5720	Screw & Washer	1
2	65-2530	Case, Clutch	1
3	65-2520	Case, Fan	1
4	60-7590	Pin, Dowel	2
5	54-5690	Snap Ring	1
6	54-5700	Washer	1
7	54-5680	Bearing, Ball	1
8	54-5670	Snap Ring	1
9	54-6250	Drum, Clutch	1
10	65-4440	Spring	1
11	60-7770	Nut, Conical Spring	1
12	65-2580	Fan	1
13	65-4450	Washer	2

Ref. No.	Part No.	Description	No. Used
14	54-6220	Shoe, Clutch	2
15	54-5290	Bolt, Clutch	2
16	60-7630	Bracket, Unit	1
17	54-4610	Screw & Washer	2
18	60-7620	Screw & Washer	1
19	65-2590	Unit, Transistor	1
20	54-6020	Wire, Lead	1
21	60-7610	Bolt & Washer	3
22	54-5740	Bolt & Washer	2
23	65-2550	Screw & Washer	1
24	65-2540	Washer, Spacer	2
*	54-6240	Clutch Assembly (Incl. Ref. #10 & 14)	1

*Not Illustrated

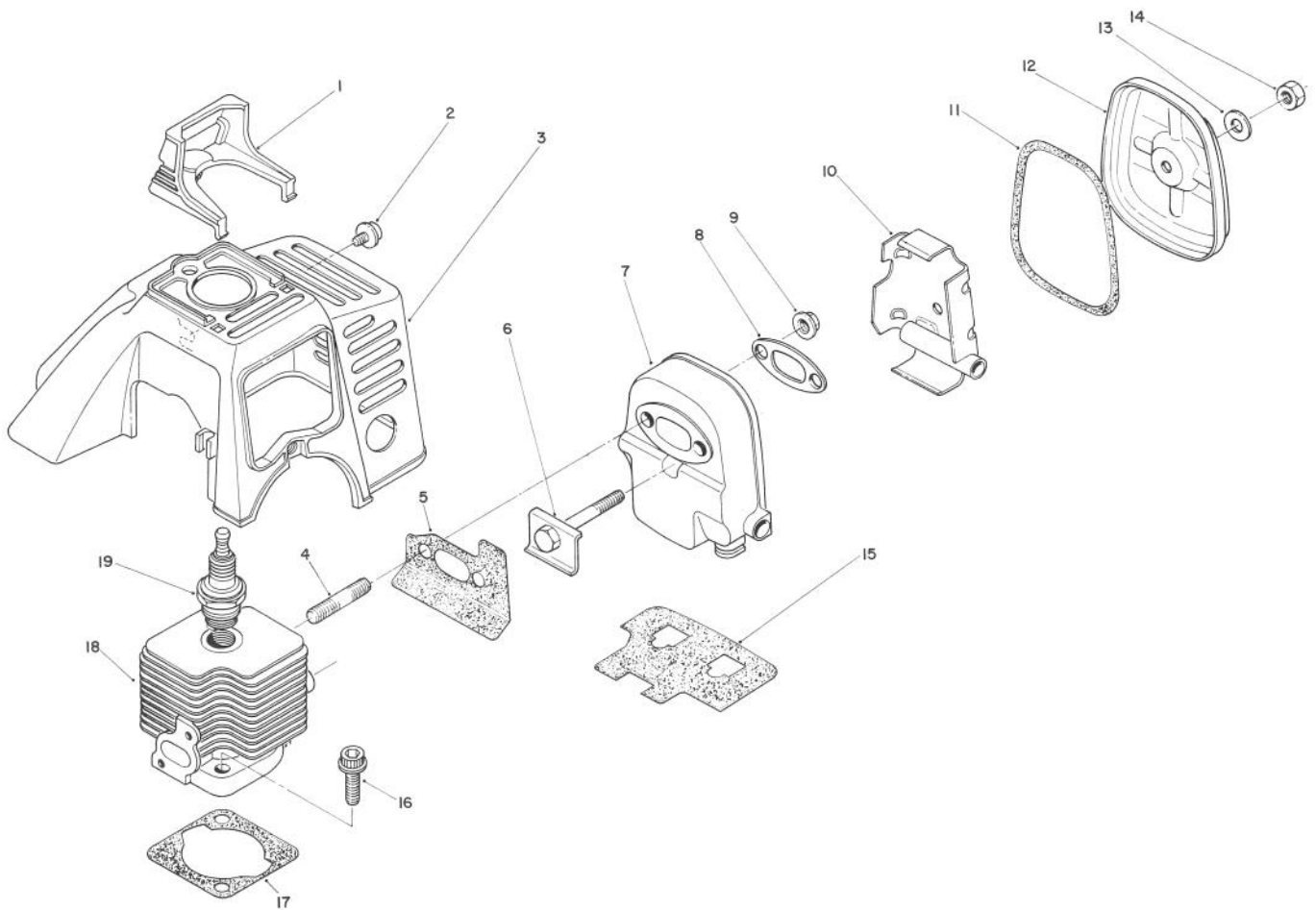

C-0214-89

CYLINDER & MUFFLER ASSEMBLY

Ref. No.	Part No.	Description	No. Used
1	60-7670	Guard, Spark Plug	1
2	60-7680	Screw & Washer	1
3	65-2560	Cover, Top	1
4	60-7700	Bolt, Stud	2
5	65-2620	Gasket, Muffler	1
6	65-2630	Bolt, Muffler Body	1
7	65-2640	Body, Muffler	1
8	60-8070	Plate	1
9	60-7770	Nut, Conical Spring	2
10	65-4400	Plate	1

Ref. No.	Part No.	Description	No. Used
11	60-8100	Gasket, Muffler Seal	1
12	60-8110	Lid, Muffler	1
13	65-4410	Washer, Gasket	1
14	65-4420	Nut	1
15	65-4430	Gasket	1
16	60-7720	Bolt, Flange	2
17	60-7730	Gasket, Cylinder	1
18	65-2570	Cylinder	1
19	45-0320	Plug, Spark	1

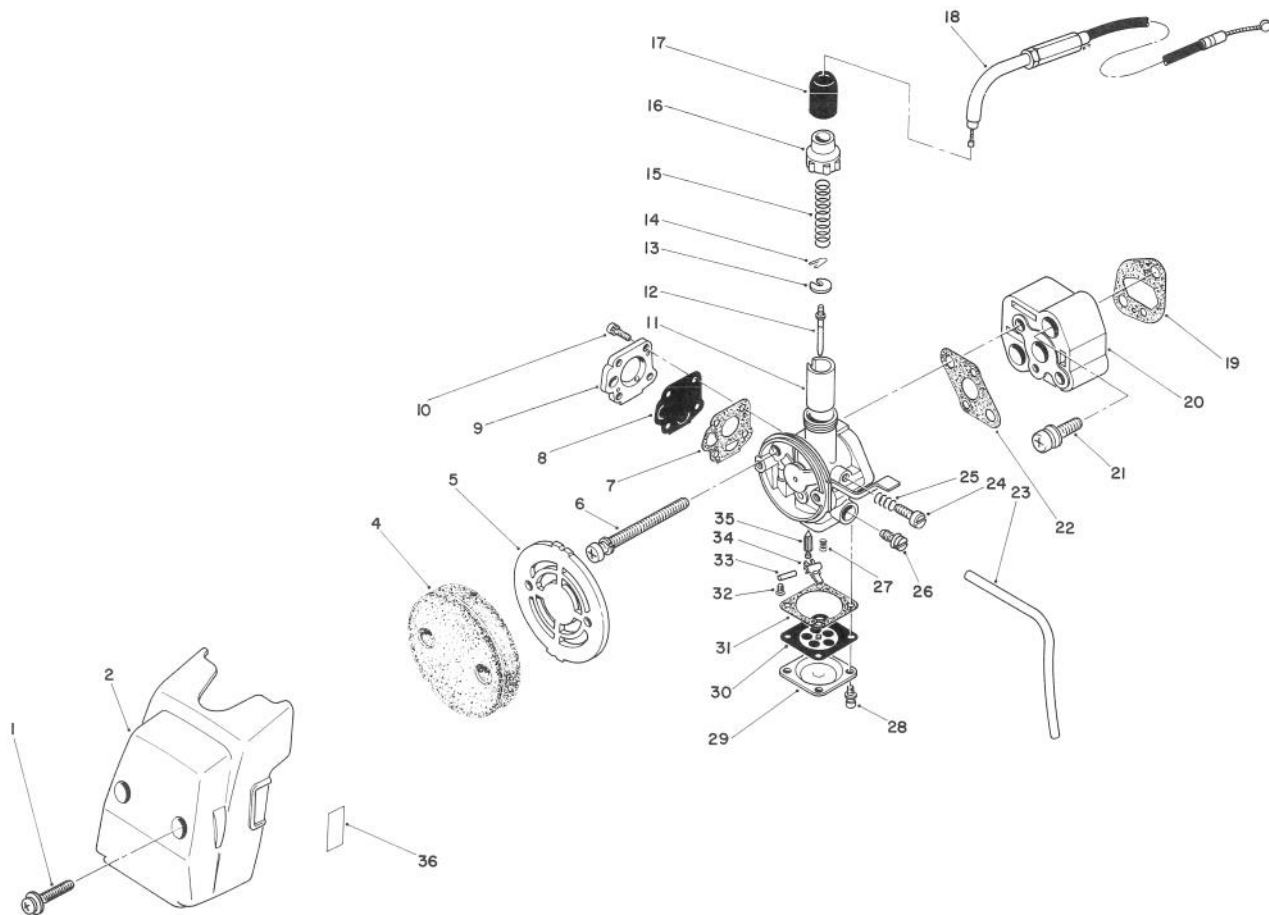

C-0215-89

CARBURETOR & AIR CLEANER ASSEMBLY

Ref. No.	Part No.	Description	No. Used
1	60-8020	Screw & Washer	2
2	65-2610	Case, Cleaner	1
4	60-8040	Element	1
5	54-5200	Grid	1
6	54-4870	Screw & Washer	2
7	54-5010	Gasket, Pump Cover	1
8	54-5020	Diaphragm, Pump	1
9	60-7980	Pump Cover Assembly	1
10	54-5040	Screw & Washer	4
11	60-7970	Valve, Throttle	1
12	60-7960	Jet Needle Assembly	1
13	60-7950	Retainer, Spring	1
14	54-5120	Clip, Needle	1
15	54-4920	Spring — Throttle	1
16	54-4910	Cap, Mixing Chamber	1
17	54-4900	Cap, Rubber	1
18	54-6140	Cable, Throttle	1
19	60-7920	Gasket, Insulator	1
20	60-7910	Insulator	1
21	60-7930	Screw & Washer	2

Ref. No.	Part No.	Description	No. Used
22	60-7940	Gasket, Carburetor	1
23	56-9000	Tube, Fuel	1
24	54-4970	Screw, Adjusting	1
25	54-4960	Spring, Adjusting Screw	1
26	54-4980	Main Jet Needle Assembly	1
27	54-4990	Spring, Inlet Valve	1
28	54-5110	Screw & Washer	4
29	54-5100	Cover, Main Diaphragm	1
30	54-5090	Main Diaphragm Assembly	1
31	54-5000	Gasket, Main Diaphragm	1
32	54-5080	Setscrew, Float Pin	1
33	54-5070	Pin, Float	1
34	54-5060	Arm, Float	1
35	54-5050	Valve, Float	1
36	54-5170	Label, Choke	1
*	60-8010	Air Cleaner Assembly (Incl. Ref. #2, 4, 5 & 36)	1
*	65-2600	Carburetor Assembly (Incl. Ref. #7-15 & 24-35)	1

*Not Illustrated

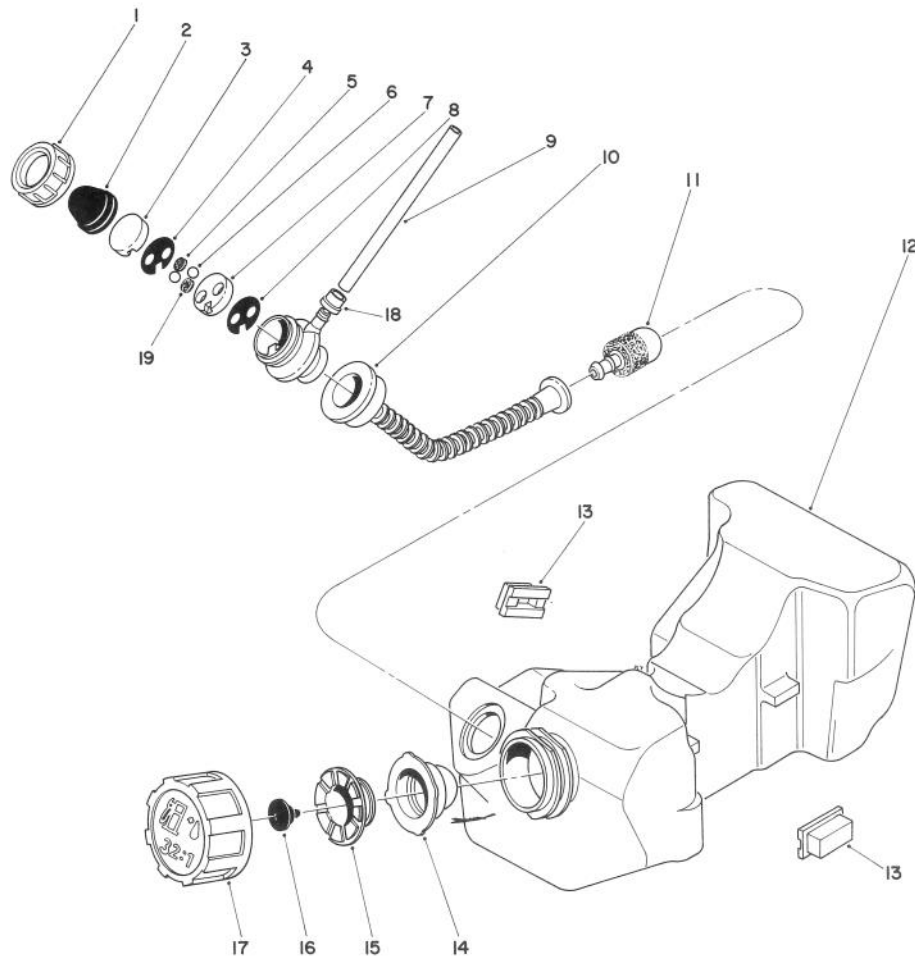

C-0216-89

FUEL TANK ASSEMBLY

Ref. No.	Part No.	Description	No. Used
1	54-5510	Nut, Cap	1
2	54-5520	Cap	1
3	54-5530	Seat, Valve	1
4	54-5460	Gasket	1
5	54-5470	Sponge	1
6	54-5480	Ball	2
7	54-5490	Seat, Valve	1
8	54-5500	Gasket	1
9	54-7040	Tube, Fuel	1
10	60-8270	Hose, Suction	1
11	54-5540	Filter, Fuel	1
12	65-4490	Fuel Tank Assembly (Incl. Ref. #1-8, 10, 11, 14-17 & 19)	1

Ref. No.	Part No.	Description	No. Used
13	60-8280	Pad	4
14	54-5630	Gasket	1
15	54-5620	Holder	1
16	54-5610	Valve, Breather	1
17	54-5600	Cap, Tank	1
18	54-5550	Clip	1
19	60-8260	Cushion, Ball	1
*	54-5590	Gas Tank & Cap Assembly (Incl. Ref. #14-17)	1
*	54-5570	Pump, Priming Assembly (Incl. Ref. #1-8 & 19)	1

*Not Illustrated

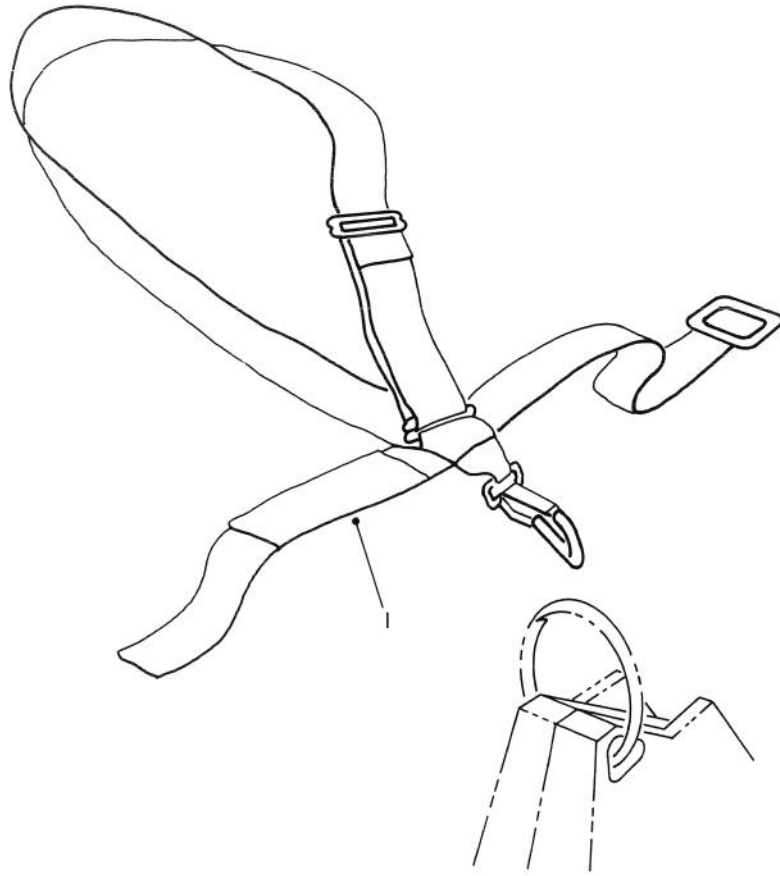

C-0217-89

DELUXE SHOULDER BELT HARNESS (Optional)

Ref. No.	Part No.	Description	No. Used
1	46-2961	Deluxe Harness Assembly	1

Ref. No.	Part No.	Description	No. Used

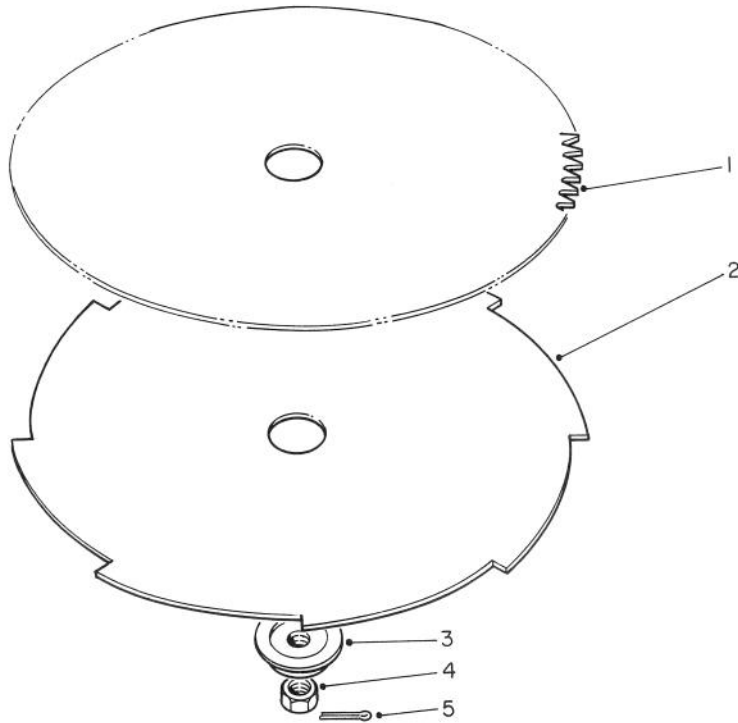

C-0218-89

SAW BLADE AND BRUSH BLADE (Optional)

Ref. No.	Part No.	Description	No. Used
1	51-1230	8" Dia. Blade (80 Tooth)	1
2	51-1240	8" Dia. Blade (8 Tooth)	1
3	41-6890	Adapter — Blade	1
4	41-5410	Nut	1

Ref. No.	Part No.	Description	No. Used
5	3272-3	Cotter Pin	1
*	41-4440	Blade Adapter Kit (Incl. Ref. #3-5)	1

*Not Illustrated

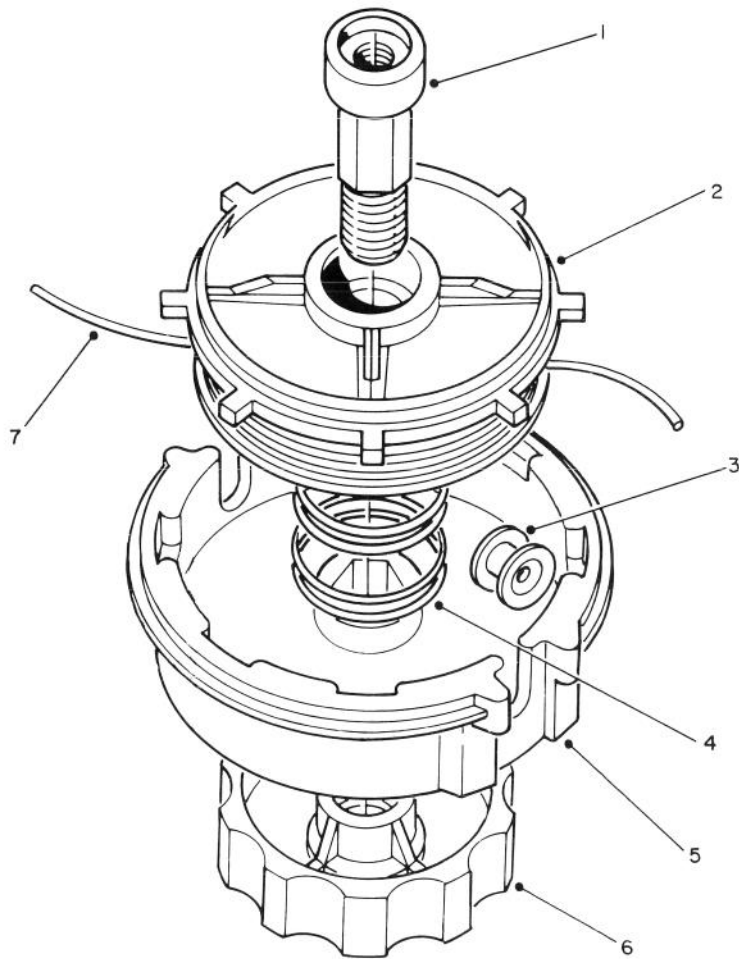

C-0219-89

MANUAL FEED HEAD ASSEMBLY NO. 57-5670 (Optional)

Ref. No.	Part No.	Description	No. Used	Ref. No.	Part No.	Description	No. Used
1	57-5610	Shaft	1	*	41-6820	.095 Line (1 Lb.-285 Ft.) (Optional)	1
2	57-5590	Spool - Inner	1	*	41-6830	.095 Line (3 Lb.) (Optional)	1
3	57-5630	Eyelet	2	*	46-2730	.105 Line (1 Lb.-235 Ft.) (Optional)	1
4	57-5620	Spring	1	*	52-5070	.105 Line (20 Ft.) (Optional)	1
5	57-5600	Housing - Spool	1	*	46-2740	.130 Line (3 Lb.-450 Ft.) (Optional)	1
6	57-5580	Knob - L.H.	1				
7		.105 Line	1				
*	43-5000	.080 Line (38 Ft.) (Optional)	1				
*	46-2710	.080 Line (1 Lb.-400 Ft.) (Optional)	1				

*Not Illustrated

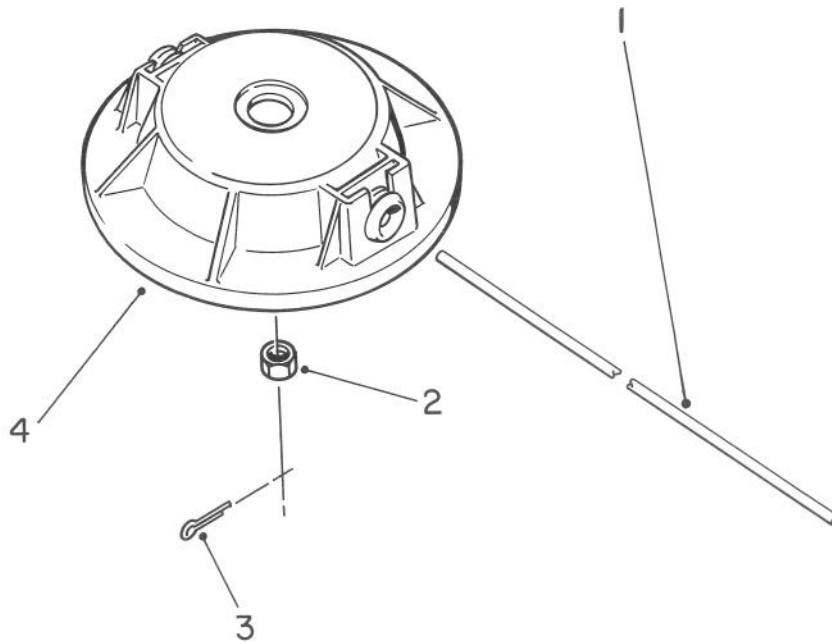

C-0220-89

FIXED LINE HEAD (Optional)

Ref. No.	Part No.	Description	No. Used
1	47-2260	.105 (100 Pcs.) (Optional)	1
*	46-2730	.105 Line (1 Lb.-235 Ft.) (Optional)	1
*	47-2250	.105 Line (24 Pcs.) (Optional)	1

Ref. No.	Part No.	Description	No. Used
2	41-5410	Hex Nut	1
3	3272-1	Cotter Pin	1
4	51-2760	Head Assembly	1

*Not Illustrated

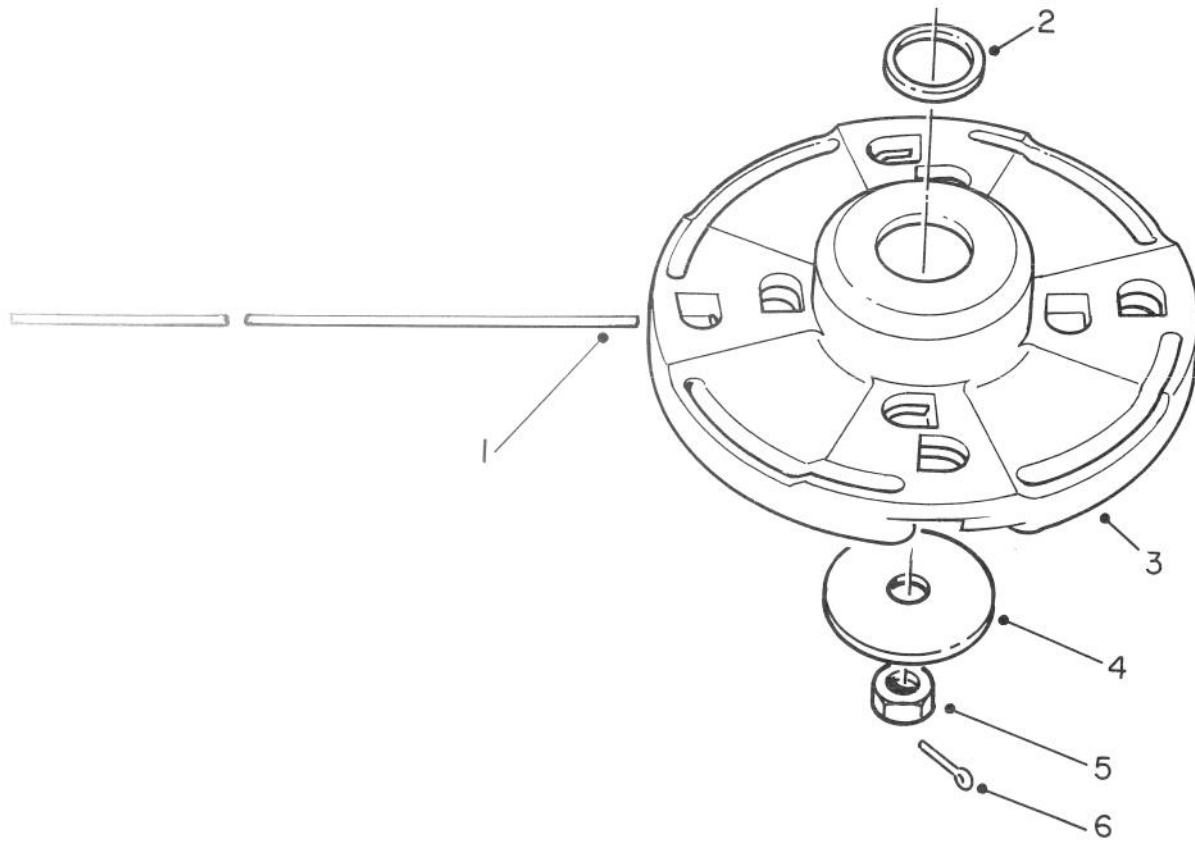

C-0221-89

FIXED LINE HEAD (Optional)

Ref. No.	Part No.	Description	No. Used
1	47-2260	.105 (100 Pcs.) (Optional)	1
*	46-2730	.105 Line (1 Lb.-235 Ft.) (Optional)	1
*	47-2250	.105 Line (24 Pcs.) (Optional)	1
*	42-0580	.130 Line & 100 Pcs.) (Optional)	1
*	46-2740	.130 Line (3 Lb.-450 Ft.) (Optional)	1

Ref. No.	Part No.	Description	No. Used
2	44-6950	Spacer	1
3	46-2810	Head Assembly (Incl. Ref. #2)	1
4	41-4430	Washer — Plate	1
5	41-5410	Hex Nut	1
6	3272-3	Cotter Pin	1

* Not Illustrated

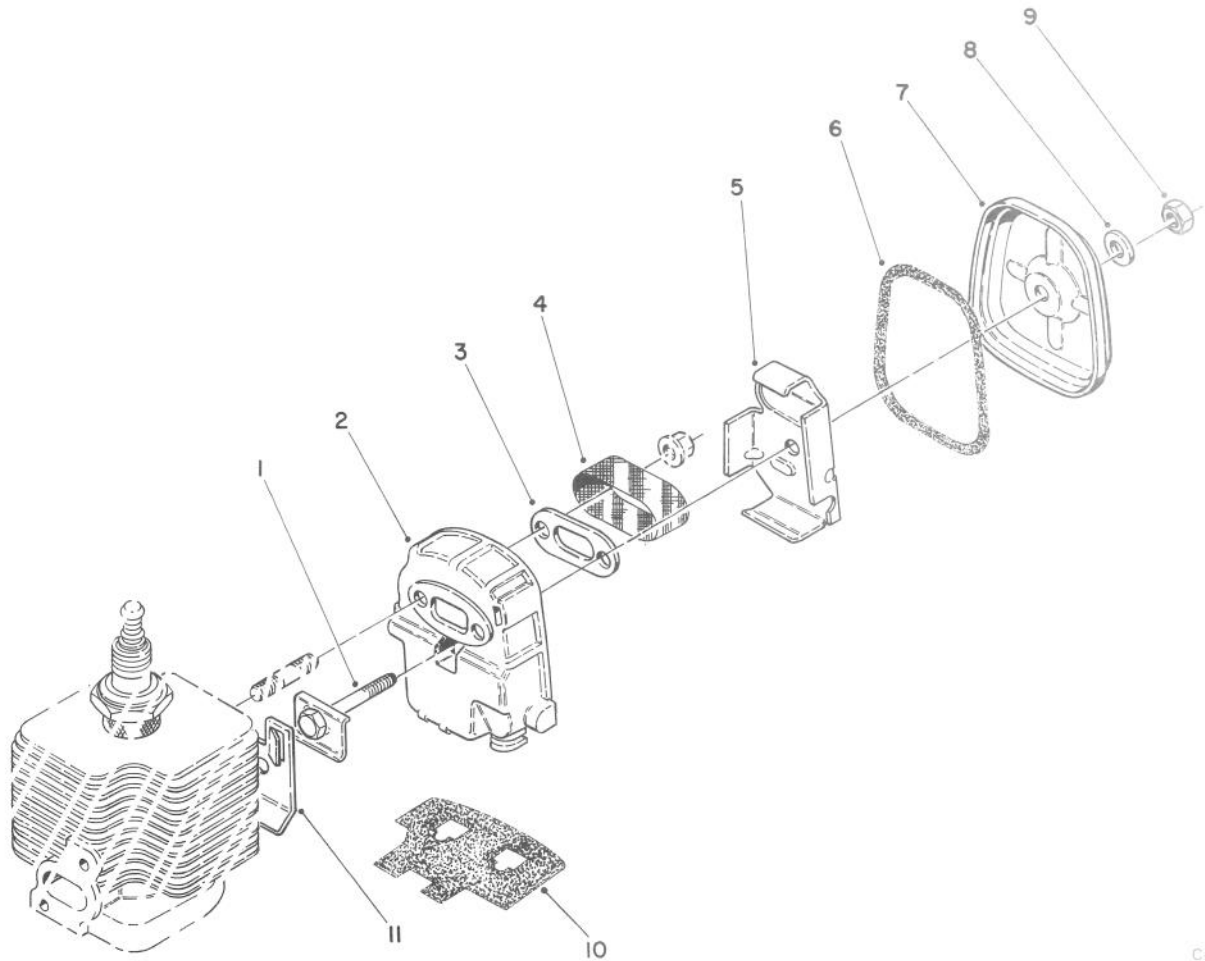

C-0222-88

SPARK ARRESTOR MUFFLER KIT 65-4300 (Optional)

Ref. No.	Part No.	Description	No. Used
1	65-2630	Bolt — Muffler Body	1
2	65-4320	Body — Muffler	1
3	65-4330	Plate	1
4	65-4340	Screen	1
5	65-4350	Plate	1
6	60-8100	Gasket — Muffler Seal	1

Ref. No.	Part No.	Description	No. Used
7	60-8110	Lid — Muffler	1
8	65-4410	Washer — Gasket	1
9	65-4420	Nut	1
10	65-4360	Gasket	1
11	65-4370	Gasket — Muffler	1

PRODUCT CHANGES

In an effort to make improvements available to TORO owners as quickly as possible, minor changes are incorporated into Toro's products from time to time that do not become immediately shown in the Parts Catalog. If such a change apparently has been made in your unit, which is not reflected in your manual, see your TORO Distributor or his Authorized TORO Service Dealer for information and part numbers.

IDENTIFICATION AND ORDERING

MODEL AND SERIAL NUMBERS

The Trimmer has two identification numbers: a model number and a serial number. The two numbers are stamped on a decal which is located in front of throttle lever on bottom side of drive shaft tube. In any correspondence concerning the trimmer, supply model and serial numbers to assure that correct information and replacement parts are obtained.

To order replacement parts from an Authorized TORO Service Dealer, supply the following information:

1. Model and serial numbers of the trimmer.
2. Part number, description, and quantity of part(s) desired.

Note: Do not order by reference number if a parts catalog is being used; use the PART NUMBER.

The Toro Promise

TORO GAS TRIMMER/WEEDER
A TWO YEAR LIMITED WARRANTY

The Toro Company promises to repair your TORO Product if defective in materials or workmanship. The following time periods from the date of purchase apply:

Residential Product 2 Years
Residential Products Used Commercially 90 Days

The costs of parts and labor are included, but the customer pays the transportation costs. Just return any residential product to an Authorized TORO Service Dealer or TORO Distributor.

Should you feel your TORO Product is defective and wish to rely on The Toro Promise, the following procedure is recommended:

1. Contact any Authorized TORO Service Dealer, TORO Master Service Dealer, or TORO Distributor (the Yellow Pages of your telephone directory is a good reference source).
2. He will either instruct you to return the product to him or recommend another Authorized TORO Service outlet which might be more convenient.
3. Bring the product along with your original sales slip, or other evidence of purchase date, to the service dealer.
4. The servicing dealer will inspect the unit, advise you whether the product is defective and, if so, make all repairs necessary to correct the defect without extra charge to you.

If for any reason you are dissatisfied with the dealer's analysis of the defect or the service performed, you may contact us.

Write:

TORO Consumer Service Department
8111 Lyndale Avenue South
Minneapolis, Minnesota 55420

The above remedy of product defects through repair by an Authorized TORO Service Dealer is the purchaser's sole remedy for any defect.

THERE IS NO OTHER EXPRESS WARRANTY. ALL IMPLIED WARRANTIES OF MERCHANTABILITY AND

FITNESS FOR USE ARE LIMITED TO THE DURATION OF THE EXPRESS WARRANTY.

Some states do not allow limitations on how long an implied warranty lasts, so the above limitation may not apply to you.

This warranty applies only to parts or components which are defective and does not cover repairs necessary due to normal wear, misuse, accidents, or lack of proper maintenance. Regular, routine maintenance of the unit to keep it in proper operating condition is the responsibility of the owner.

All warranty repairs reimbursable under The Toro Promise must be performed by an Authorized TORO Service Dealer using Toro approved replacement parts.

Repairs or attempted repairs by anyone other than an Authorized TORO Service Account are not reimbursable under The Toro Promise. In addition, these unauthorized repair attempts may result in additional malfunctions, the correction of which is not covered by warranty.

THE TORO COMPANY IS NOT LIABLE FOR INDIRECT, INCIDENTAL OR CONSEQUENTIAL DAMAGES IN CONNECTION WITH THE USE OF THE PRODUCT INCLUDING ANY COST OR EXPENSE OF PROVIDING SUBSTITUTE EQUIPMENT OR SERVICE DURING PERIODS OF MALFUNCTION OR NON-USE.

Some states do not allow the exclusion or limitation of incidental or consequential damages, so the above limitation or exclusion may not apply to you.

This warranty gives you specific legal rights, and you may also have other rights which vary from state to state.

COUNTRIES OTHER THAN THE UNITED STATES OR CANADA

Customers who have purchased TORO products exported from the United States or Canada should contact their TORO Distributor (Dealer) to obtain guarantee policies for your country, province or state. If for any reason

you are dissatisfied with your Distributor's service or have difficulty obtaining guarantee information, contact the TORO importer. If all other remedies fail, you may contact us at The Toro Company.

MAINTENANCE RECORD

Date								

MAINTENANCE RECORD

Date								