



Trencher Chain Compact Utility Loaders

Model No. 22462

Model No. 22466

Model No. 22468

Model No. 22950

Model No. 22952

Model No. 22954

Model No. 22463

Model No. 22467

Model No. 22469

Model No. 22951

Model No. 22953

Model No. 22955

Parts Catalog

Ordering Replacement Parts

To order replacement parts, please supply the part number, the quantity, and the description of each part desired.

Understanding Reference Numbers

Each Identified part in an illustration has a reference number. The reference number for a part also appears in the parts list, along with other information about the part.

This catalog uses two special reference number formats, one to indicate parts in a service assembly and another to indicate the quantity of a given part in an illustration.

Service Assembly Reference Numbers

Parts in service assemblies have reference numbers in the form a:b. The a represents the reference number of the entire service assembly and the b represents a sequential number unique to each part within the service assembly.

For example, a wheel assembly might be identified by reference number 6, the tire by 6:1, the valve by 6:2, and the wheel by 6:3. When you order the assembly identified by reference number 6, you receive all parts identified by reference numbers 6:1, 6:2, and 6:3. However, you may also order any part individually. Reference numbers of this type appear in illustrations and in part lists.

Reference Numbers Indicating Quantity

In an illustration, if a reference number indicates more than one part, the reference number has the form nX y. The n represents the quantity of the part, the X is the multiplication symbol, and the y represents the reference number.

For example, in an illustration, the reference number 2X 37 means that two of the parts identified by reference number 37 are indicated.

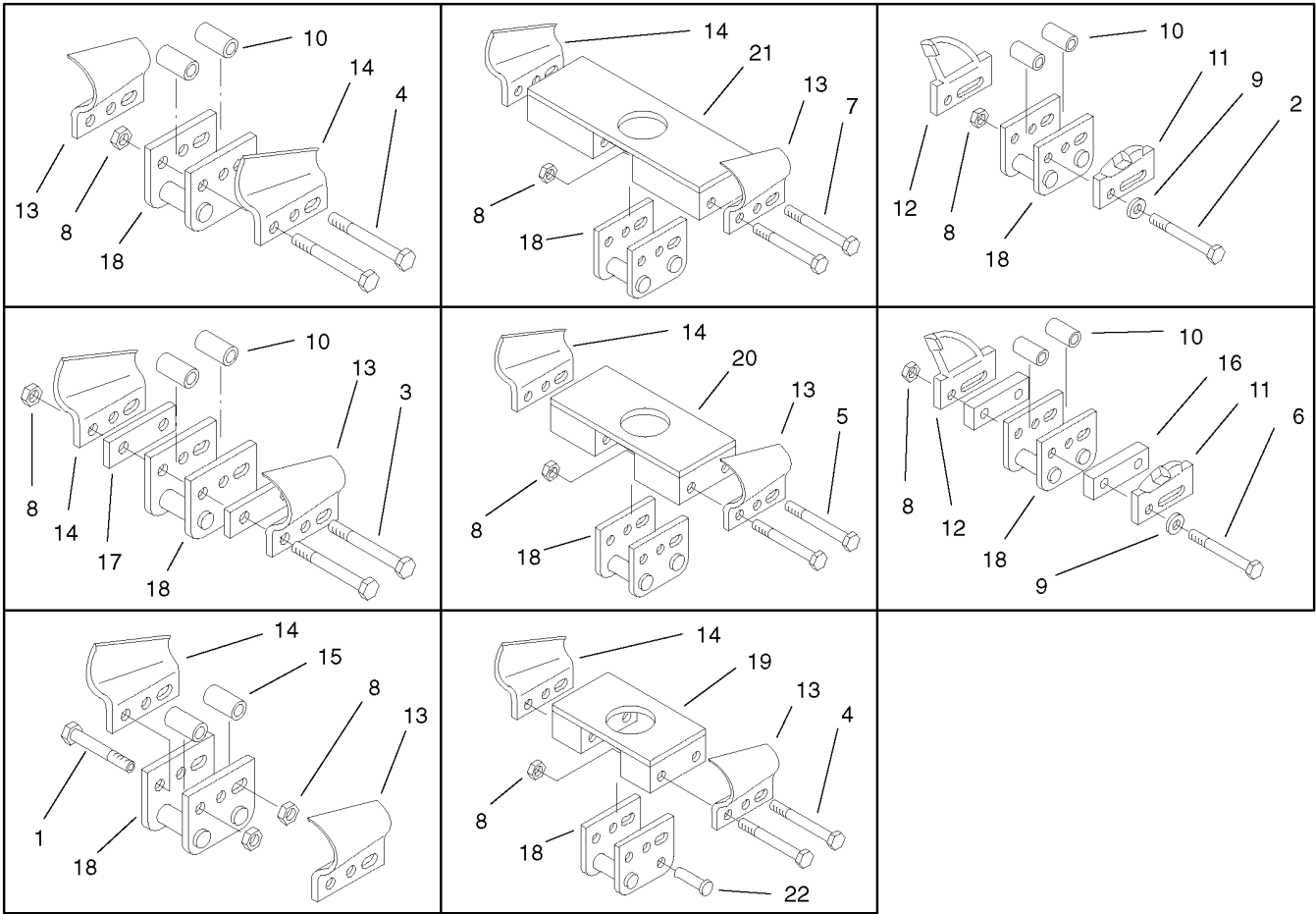

Chain Assemblies

Ref	Part No.	Qty.	Description
1	104-5936	1	Screw-HH
2	104-5937	1	Screw-HH
3	104-5938	1	Screw-HH
4	3211-42	1	Screw-HH
5	3211-43	1	Screw-HH
6	3211-44	1	Screw-HH
7	3211-45	1	Screw-HH
8	32146-6	1	Nut
9	3256-38	1	Washer-Flat
10	98-8222	1	Spacer-Tube
11	99-5922	1	Tooth-Rock, LH
12	99-5923	1	Tooth-Rock, RH
13	99-5924	1	Tooth-Soil, LH
14	99-5925	1	Tooth-Soil, RH
15	99-5926	1	Spacer-Tube
16	99-5929	1	Spacer-Cut, 6 Inch
17	99-5930	1	Spacer-Cut
18	99-5931	1	Chain-Bare, 32 Inch (TAP)
18	104-5848	1	Chain-Bare, 24 Inch (Station)
19	99-9972	1	Adapter-8 Inch
20	99-9973	1	Adapter-10 Inch
21	99-9974	1	Adapter-12 Inch
22	104-5855	1	Pin-Connecting

--	--	--	--