



Vibratory Plow
for Compact Utility Loaders

Model No. 22910—200000001 & Up

Operator's Manual

Contents

	Page
Introduction	2
Safety	2
Sound Pressure Level	3
Vibration Level	3
Safety Decals	4
Specifications	4
Stability Ratings	4
Installation	5
Installing a Blade	5
Removing the Plow from the Traction Unit	5
Operation	6
Plowing	6
Transporting the Plow	6
Gauging Plow Depth	7
Tips for Plowing	7
Maintenance	8
Service Interval Chart	8
Greasing	8
Lubrication	9
Replacing the Coulter	9
Storage	10
Troubleshooting	10

Introduction

We want you to be completely satisfied with your new product, so feel free to contact your local Authorized Service Dealer for help with service, genuine replacement parts, or other information you may require.

Whenever you contact your Authorized Service Dealer or the factory, always know the model and serial numbers of your product. These numbers will help the Service Dealer or Service Representative provide exact information about your specific product. You will find the model and serial number on a plate located on the attachment receiver plate. For your convenience, write the product model and serial numbers in the space below.

Model No: _____
Serial No. _____

The warning system in this manual identifies potential hazards and has special safety messages that help you and others avoid personal injury, even death. DANGER, WARNING and CAUTION are signal words used to identify the level of hazard. However, regardless of the hazard, be extremely careful.

DANGER signals an extreme hazard that will cause serious injury or death if the recommended precautions are not followed.

WARNING signals a hazard that may cause serious injury or death if the recommended precautions are not followed.



CAUTION signals a hazard that may cause minor or moderate injury if the recommended precautions are not followed.



Two other words are also used to highlight information. “Important” calls attention to special mechanical information and “Note” emphasizes general information worthy of special attention.



The left and right side of the machine is determined by standing in the normal operator’s position.

Safety

Improper use or maintenance by the operator or owner can result in injury. To reduce the potential for injury, comply with the safety instructions in the traction unit operator’s manual and always pay attention to the safety alert  symbol, which means CAUTION, WARNING, or DANGER—“personal safety instruction.” Failure to comply with the instruction may result in personal injury or death.

	DANGER	
POTENTIAL HAZARD		
<ul style="list-style-type: none"> • There may be buried power, gas, and/or telephone lines in the area being plowed. 		
WHAT CAN HAPPEN		
<ul style="list-style-type: none"> • Shock or explosion may occur. 		
HOW TO AVOID THE HAZARD		
<ul style="list-style-type: none"> • Have the area to be plowed marked for buried lines and do not plow in marked areas. 		

	DANGER	
POTENTIAL HAZARD		
<ul style="list-style-type: none"> • Contact with moving plow may cause injury. 		
WHAT CAN HAPPEN		
<ul style="list-style-type: none"> • The moving plow can cut hands, feet, or other body parts. 		
HOW TO AVOID THE HAZARD		
<ul style="list-style-type: none"> • Keep your hands, feet, and any other part of your body or clothing away from moving parts. • Before adjusting, cleaning, repairing, and inspecting the plow, lower it to the ground, stop the engine, remove the key, and wait for all moving parts to stop. 		

 **WARNING** 

POTENTIAL HAZARD



- If you do not fully seat the attachment locking pins in the attachment mount plate holes, the attachment could fall off of the traction unit.

WHAT CAN HAPPEN

- The attachment could fall rearward onto the operator, severely injuring him or her.
- Bystanders may be severely injured by the attachment as it falls.

HOW TO AVOID THE HAZARD

- Ensure that you fully seat the attachment locking pins through the holes in the attachment mount plate before lifting the attachment.
- Ensure that the attachment mount plate is free of any dirt or debris that may hinder the connection of the traction unit to the attachment.
- Refer to your traction unit *Operator's Manual* for detailed information on safely connecting an attachment to your traction unit.

 **WARNING** 

POTENTIAL HAZARD



- When the engine is off, attachments in the raised position can gradually lower.

WHAT CAN HAPPEN

- Someone nearby may be pinned or injured by the attachment as it lowers.

HOW TO AVOID THE HAZARD

- Always lower the attachment lift each time you shut off the traction unit.

 **WARNING** 

POTENTIAL HAZARD



- The plow is very loud during operation.

WHAT CAN HAPPEN

- Over time, your hearing may be impaired if unprotected.

HOW TO AVOID THE HAZARD

- Wear hearing protection during operation.

 **WARNING** 

POTENTIAL HAZARD



- When the plow is out of the ground, bystanders could be injured by the swinging plow.
- The traction unit could be overturned by the inertia of the swinging plow.

WHAT CAN HAPPEN

- You or bystanders could be crushed by the traction unit or plow.

HOW TO AVOID THE HAZARD

- Keep the plow low at all times.
- Use caution when turning and do not turn quickly.
- Keep all bystanders at least 6 ft. (2 meters) away while operating.

 **CAUTION** 

POTENTIAL HAZARD

- Hydraulic couplers, hydraulic lines/valves, and hydraulic fluid may be hot.

WHAT CAN HAPPEN

- Contact with hot hydraulic components or fluid may cause burns.

HOW TO AVOID THE HAZARD

- Wear gloves when operating the hydraulic couplers.
- Allow the traction unit to cool before touching hydraulic components.
- Do not touch hydraulic fluid spills.

Sound Pressure Level

This unit has a maximum sound pressure at the operator's ear of 117 dB(A), based on measurements when operated on a traction unit per Directive 81/1051/EEC. The sound pressure level will vary depending on conditions.

Vibration Level

This unit has a maximum hand-arm vibration level of 7 m/s² and whole body vibration level of 0.2 m/s² based on measurements of identical machines per EN 1033 and EN 1032.

Safety Decals

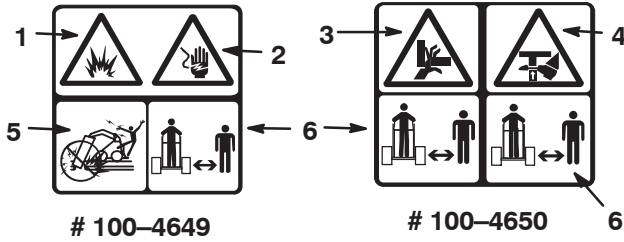

Figure 1

1. Explosion hazard
2. Shock hazard
3. Pinching/crushing hazard—hand
4. Pinching/crushing hazard—foot
5. Do not dig in areas with underground utility lines
6. Keep bystanders away

Specifications



Note: Specifications and design are subject to change without notice.

Width	29 inches (73.6 cm)
Length	35 inches (89 cm)
Height	24 inches (60 cm)
Weight (without blade)	400 lbs (181.5 Kg)
Hydraulic motor displacement	1.27 in ³ /rev (20.8 cc)
Plow cycles	1,528 VPM

Stability Ratings

To determine the maximum degree of slope you can traverse with the plow installed on a traction unit, find the stability rating for the hill orientation you want to travel in

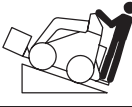
the table below, then find the degree of slope for the same rating and orientation in the Stability Data section of the traction unit operator's manual.

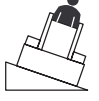
Orientation	Stability Rating
Front Uphill 	C
Rear Uphill 	D
Side Uphill 	C

IMPORTANT: If your traction unit has a rear operator's platform, the counterweight must be used on the platform while using the plow, or the traction unit will become unstable.

! **WARNING** !

POTENTIAL HAZARD

- Exceeding the maximum recommended slope can cause the traction unit to tip.

WHAT CAN HAPPEN

- If the traction unit tips, you or bystanders could be crushed.

HOW TO AVOID THE HAZARD

- Do not drive the traction unit on a slope steeper than the maximum recommended slope, as determined in the previous table and the traction unit operator's manual.

Installation

Refer to your traction unit *Operator's Manual* for complete instructions on installing attachments onto the traction unit and connecting hydraulic hoses.

Installing a Blade

Toro offers several different blades and pullers. Purchase a blade and puller from your Toro dealer.

1. Raise the plow about 36 in. (1 m) off of the ground and install the cylinder locks.
2. Stop the engine and remove the key.
3. Remove the two click pins from the clevis pins in the blade bracket, then remove the clevis pins (Fig. 2).
4. Slide the blade into the blade bracket and secure it at the desired depth (a change in mounting holes will change the depth by 3 in. (7.6 cm)), using the clevis pins and click pins removed previously (Fig. 2).

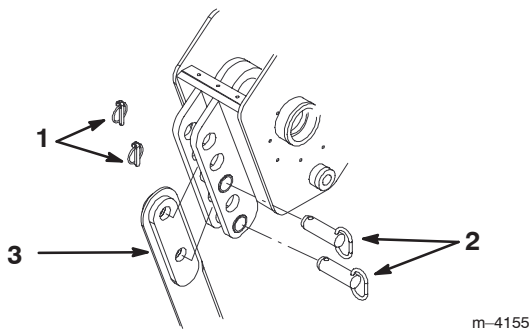



Figure 2

1. Click pin
2. Clevis pin
3. Blade

Removing the Plow from the Traction Unit

Refer to your traction unit operator's manual for complete instructions on removing attachments from the traction unit and disconnecting hydraulic hoses.

1. With the plow raised above the ground, stop the engine.
2. Remove the lower click pin and clevis pin securing the blade to the plow (to completely remove the blade, remove both the upper and lower click and clevis pins) (Fig. 2).
3. Swing the blade up and secure it as illustrated in Figure 3.

**CAUTION**

POTENTIAL HAZARD

- The blade is sharp and has pinch points.

WHAT CAN HAPPEN

- The blade can swing and pinch or crush hands or feet.

HOW TO AVOID THE HAZARD

- Wear gloves and work boots and securely hold the blade.

4. Tilt the plow forward and lower it to the ground or trailer, with the stand and coulter supporting the weight of the plow (Fig. 3).

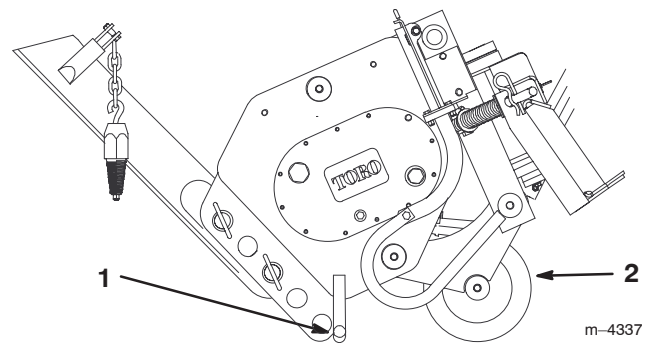

Figure 3

1. Stand
2. Coulter

5. Stop the engine and remove the plow as directed in your traction unit operator's manual.

Operation

IMPORTANT: Always use the traction unit to lift and move the attachment.

Plowing

1. Move the lynch pins to the outside holes on the spring rods to allow the plow to move from side to side (Fig. 4).

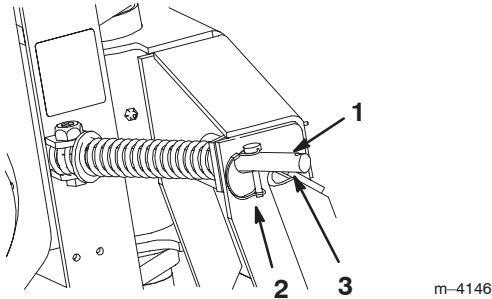

Figure 4

1. Outer hole
2. Lynch pin (in inner hole)
3. Spring rod



CAUTION



POTENTIAL HAZARD

- When you remove the lynch pin, the plow is free to swing.

WHAT CAN HAPPEN

- The plow could swing into you or a bystander, or cause the traction unit to become unstable.

HOW TO AVOID THE HAZARD

- Hold the plow in the neutral position when moving the lynch pins.

2. Connect the material being installed to the plow as described in the blade *Installation Instructions*.
3. If your traction unit has a speed selector, move it to the slow (turtle) position.
4. Start the engine.
5. Tilt the attachment plate completely back so that the top of the plow is parallel to the ground (Fig. 6)
6. Lower the plow so that it is resting on the ground.

IMPORTANT: Always ensure that the plow is on or in the ground before engaging the auxiliary hydraulics lever. Failure to do so will cause excessive vibration of the traction unit, possibly resulting in damage.

Note: If you dig a hole to lower the blade into before starting, it will reduce the risk of bending the blade.

7. Pull the auxiliary hydraulics lever to the operator grip to engage the plow.
8. Slowly lower the plow into the ground to the desired depth, while moving the traction unit backward.
9. When finished, release the auxiliary hydraulics lever to stop the plow.



CAUTION



POTENTIAL HAZARD

- When plowing on a hill, the plow can swing down hill when raised out of the soil.

WHAT CAN HAPPEN

- Due to the weight of the plow, if it swings too fast, the force could tip the traction unit injuring you or others.

HOW TO AVOID THE HAZARD

- When plowing on a hill, raise the plow out of the ground slowly, letting it swing while the blade is still in the soil.

10. Raise the plow out of the ground far enough to pull the puller out of the soil.
11. Move the traction unit rearward to pull out a working length of material, then move forward slightly to create some slack in the line.
12. Stop the engine.

Transporting the Plow

1. Move the lynch pins to the inside holes on the spring rods to prevent side to side movement (Fig. 4).



CAUTION



POTENTIAL HAZARD

- Failure to secure the plow will allow it to swing side to side and unbalance the plow.

WHAT CAN HAPPEN

- Due to the weight of the plow, if it swings too fast, the force could tip the traction unit injuring you or others.

HOW TO AVOID THE HAZARD

- Always secure the plow with the lynch pins in the inner holes of the spring rods before transporting the plow.

2. Raise the loader arms just enough to ensure that the blade clears the ground.

IMPORTANT: Never transport the plow with the arms fully raised.

Gauging Plow Depth

Normally, you will be plowing at the maximum depth set by the blade; however, the plow is also equipped with a gauge to allow you to lift the plow and determine how high above maximum depth you are plowing.

The gauge is located on the the left side of the plow facing the traction unit. A rod assembly runs from the gauge to the ground. When the plow is lifted, the indicator on the gauge moves down. Marks on the gauge show the number of inches lower or higher than the maximum depth that you are plowing. The gauge reads from +2 to -3 inches (+5 to -7.6 cm), with zero being the maximum depth on bare ground and -3 being 3 inches (7.6 cm) above maximum depth. Figures 5 and 6 illustrate the gauge.

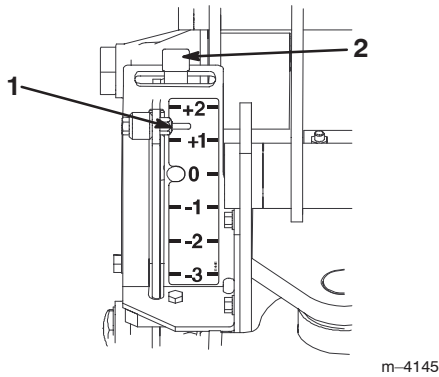

Figure 5

- 1. Depth gauge
- 2. Gauge locking lever

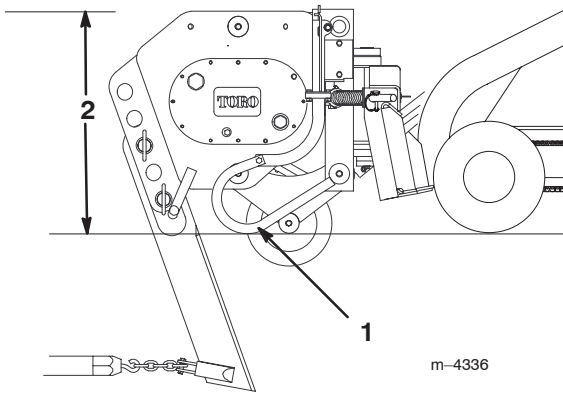

Figure 6

- 1. Gauge rod assembly
- 2. Parallel to the ground

When plowing bare ground, maximum depth is indicated on the gauge as the zero mark. You can plow down to the +1 mark, but in this case you will be contacting the ground with the coulter axle. Plowing any lower may damage the coulter.

When plowing grass covered ground, the gauge will read about an inch lower than the actual depth because of the grass. In this case, lower the plow to the desired coulter depth and note the reading on the gauge.

If you are transporting the plow or are plowing rough terrain, you can lock the gauge at the +2 position to keep it from being damaged. To lock the gauge, manually raise it to the +2 position and move the locking lever to the left.

Tips for Plowing

- When plowing long runs it is advisable to install two hairpin cotters through the spring and quick attach pins on the mount plate (Fig. 7). This will ensure that the vibration of the plow will not cause the pins to come loose.

Note: If your quick attach pins do not have holes in them for the hairpin cotters, contact your dealer to obtain new quick attach pins.

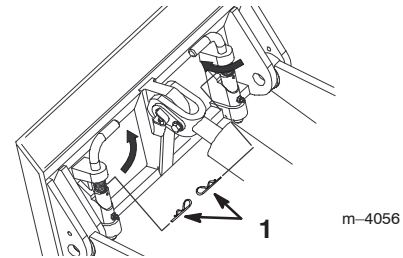

Figure 7

- 1. Hairpin cotters

- To reduce wear on the traction unit drive chain (if your model has one), tighten the chain so there is only 2 in. (5 cm) of slack on the upper span (refer to your traction unit *Operator's Manual* for instructions).
- Clean the area of trash, branches and rocks before plowing to prevent equipment damage.
- Always begin plowing with the slowest ground speed possible. Increase speed if conditions permit, but do not allow the tires or tracks to spin. Spinning the tracks or tires will cause turf damage and place stress on the traction unit.
- Always use full throttle (maximum engine speed) when plowing.
- Always plow backwards (i.e., in reverse).
- If your traction unit has a speed selector and a flow divider, move the speed selector to slow (turtle) and the flow divider to the 10 o'clock position.
- Avoid sharp turns when plowing to increase productivity and minimize ground disturbance.

- If your traction unit has tires and you have the agricultural or Sitework Systems tires installed on the traction unit, remove the tires and move the right side

tires to the left and the left side tires to the right. This will ensure that the tire tread points to the rear to give you the most traction when using the vibratory plow.

Maintenance

Service Interval Chart

Service Operation	Each Use	5 Hours	25 Hours	200 Hours	Storage Service	Notes
Grease pivot pin fittings		X			X	
Gear lube oil—check level			X			
Gear lube oil—change				X		
Chipped surfaces—paint					X	

! **CAUTION** !

POTENTIAL HAZARD

- If you leave the key in the ignition switch, someone could start the engine.

WHAT CAN HAPPEN

- Accidental starting of the engine could seriously injure you or other bystanders.

HOW TO AVOID THE HAZARD

- Remove the key from the ignition switch before you do any maintenance.

Greasing

Service Interval/Specification

Grease 6 fittings, as shown in Figures 8 through 11, every 8 operating hours. Grease all fittings immediately after every washing.

Grease Type: General-purpose grease.

Fitting Locations

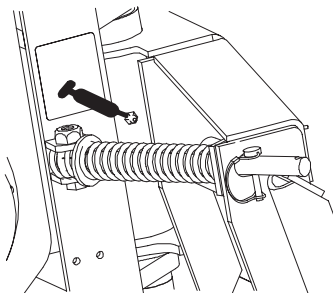

Figure 8

m-4146

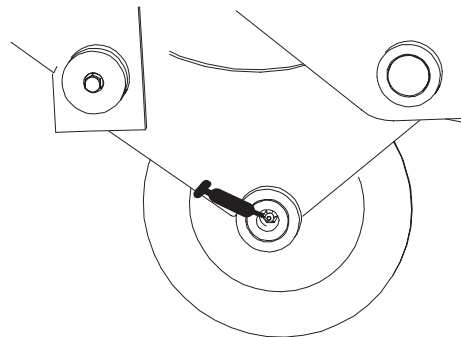
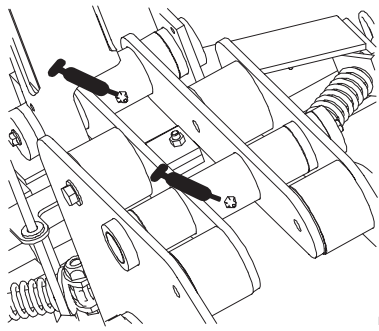

Figure 9

m-4148



m-4150

Figure 10

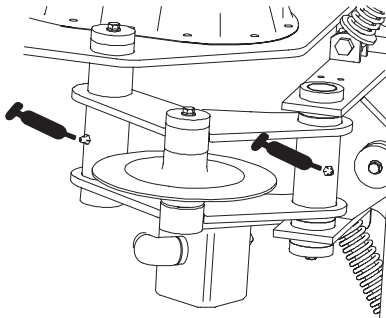

m-4151

Figure 11

How to Grease

1. Lower the plow/loader arms, stop the engine, and remove the key.
2. Clean the grease fittings with a rag.
3. Connect a grease gun to the fittings.
4. Pump grease into the fittings until grease begins to ooze out of the bearings.
5. Wipe up any excess grease.

Lubrication

Service Interval/Specification

Check the gear lubrication oil level in the gear case every 25 operating hours and change it every 200 operating hours or once a year, whichever occurs first.

Gear lube type: SAE 90–140 API service GL-4 or GL-5

Refill capacity: 3 pints.

Checking Gear Lube

1. Position the traction unit and plow on a level surface and lower the attachment lift so that the plow is on the ground.
2. Stop the engine and remove the key.

3. Check the clear glass gauge on the side of the gear case (Fig. 12). The gear lube should be at the level of the red dot in the center of the gauge.
4. If the gear lube level is low, remove the fill plug (Fig. 12) and fill the case with gear lube until it is level with the red dot in the gauge.

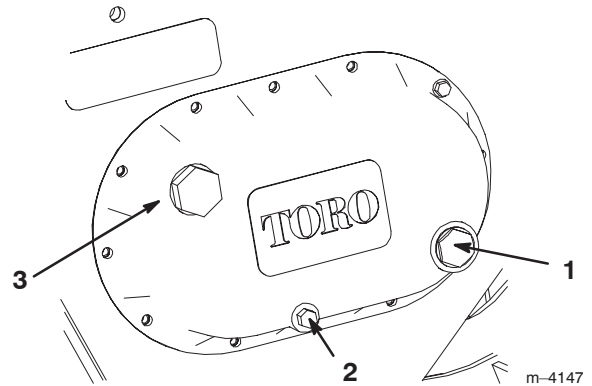

m-4147

Figure 12

1. Glass gauge
2. Drain plug
3. Fill plug

5. Replace the fill plug.

Changing Gear Lube

1. Position the traction unit and plow on a level surface and lower the attachment lift so that the plow is on the ground.
2. Stop the engine and remove the key.
3. Prepare an appropriate container to catch the used oil under the plow.
4. Remove the drain plug (Fig. 12), allowing the oil to spill out into the container.
5. When finished, replace the drain plug, ensuring that it is tight.
6. Remove the fill plug (Fig. 12) and fill the case with gear lube until it is level with the red dot in the gauge.
7. Replace the fill plug.

Replacing the Coultter

If the coultter becomes excessively worn or damaged, replace it.

1. Back out the coultter pin screw about 0.5 in. (1.3 cm), then strike it several times with a hammer to loosen the pin (Fig. 13).
2. Completely remove the coultter pin screw, washer, coultter, and coultter pin (Fig. 13).
3. Put the new coultter into the coultter bracket (Fig. 13).

- Slide the coulter pin through the bracket and coulter and secure it with the coulter pin screw and washer (Fig. 13).

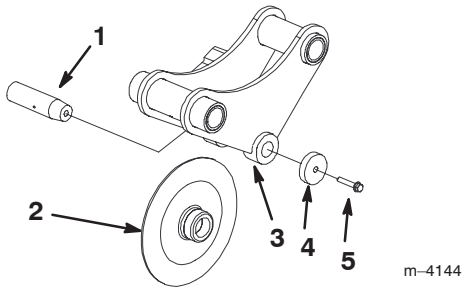

Figure 13

- | | |
|--------------------|----------------------|
| 1. Coulter pin | 4. Washer |
| 2. Coulter | 5. Coulter pin screw |
| 3. Coulter bracket | |

- Torque the screw to 45 ft. lbs (61 N·m).

Storage

- Before long term storage, wash the attachment with mild detergent and water to remove dirt and grime.
- Grease the plow.
- Check gear case lubrication.
- Check and tighten all bolts, nuts, and screws. Repair or replace any part that is damaged or worn.
- Ensure that all hydraulic couplers are connected together to prevent contamination of the hydraulic system.
- Paint all scratched or bare metal surfaces. Paint is available from your Authorized Service Dealer.
- Store the attachment in a clean, dry garage or storage area. Cover it to protect it and keep it clean.

Troubleshooting

PROBLEM	POSSIBLE CAUSES	CORRECTIVE ACTION
The plow does not operate.	<ol style="list-style-type: none"> Hydraulic coupler not completely connected Damaged hydraulic coupler An obstruction in a hydraulic hose Auxiliary valve on the traction unit is not opening. 	<ol style="list-style-type: none"> Check and tighten all couplers. Check couplers and replace any that are damaged. Find and remove the obstruction. Repair the valve.

!
!

WARNING

POTENTIAL HAZARD

- Hydraulic fluid escaping under pressure can penetrate skin and cause injury.

WHAT CAN HAPPEN

- Fluid accidentally injected into the skin must be surgically removed within a few hours by a doctor familiar with this form of injury or gangrene may result.

HOW TO AVOID THE HAZARD

- Keep body and hands away from pin hole leaks or nozzles that eject high pressure hydraulic fluid.
- Use cardboard or paper to find hydraulic leaks, never use your hands.

