



Pro Sweep 5200

Model No. 07065 - 250000201 and up.

Parts Catalog

Ordering Replacement Parts

To order replacement parts, please supply the part number, the quantity, and the description of each part desired.

Understanding Reference Numbers

Each identified part in an illustration has a reference number. The reference number for a part also appears in the parts list, along with other information about the part.

This catalog uses two special reference number formats, one to indicate parts in a service assembly and another to indicate the quantity of a given part in an illustration.

Service Assembly Reference Numbers

Parts in service assemblies have reference numbers in the form a:b. The a represents the reference number of the entire service assembly and the b represents a sequential number unique to each part within the service assembly.

For example, a wheel assembly might be identified by reference number 6, the tire by 6:1, the valve by 6:2, and the wheel by 6:3. When you order the assembly identified by reference number 6, you receive all parts identified by reference numbers 6:1, 6:2, and 6:3. However, you may also order any part individually. Reference numbers of this type appear in illustrations and in part lists.

Reference Numbers Indicating Quantity

In an illustration, if a reference number indicates more than one part, the reference number has the form nX y. The n represents the quantity of the part, the X is the multiplication symbol, and the y represents the reference number.

For example, in an illustration, the reference number 2X 37 means that two of the parts identified by reference number 37 are indicated.

Contents

Description	Page	Description	Page
Main Frame and Axle Assembly 3	Hopper Assembly 13
Trailer Axle Assembly No. 107-1529 4	Hopper Lid and Baffle Assembly 14
Pitch Frame and Cylinder Assembly 5	Hose Assembly 15
Hydraulic Cylinder Assembly No. 107-1310 6	Manifold Block Assembly No. 107-1400 16
Saddle Frame Assembly 7	Tongue Assembly 17
Brush Housing Assembly 8	Wire Harness Assembly 18
Brush, Motor and Shield Assembly 9	Remote Control Box Assembly No. 107-1382 19
Hydraulic Motor Assembly No. 105-9455 10	Hydraulic Fitting Assembly 20
Brush Assembly No. 107-1452 11	Control Box Mounting Assembly 21
Roller Assembly 12	Attachments and Accessories List 22

Part Description Abbreviations

Part descriptions in this catalog may include the following abbreviations.

AR. as required	HWHTF. hex washer head thread forming
ASM. assembly	HYD. hydraulic
BBC. blade brake clutch	INC. incorporated
CARR. carriage	LH. left hand
DEG. degrees	NI. nylon insert
EXT. external	NPTF. national pipe thread fine
FH. flat head	PFH. phillips flat head
GA. gauge	PPH. phillips pan head
HF. hex flange	PPHTF. phillips pan head thread forming
HH. hex head	PRH. phillips round head
HHF. hex head flange	PTH. phillips truss head
HHFTF. hex head flange thread forming	PTO. power take off
HJ. hex jam	RH. right hand
HLH. hex lag head	ROPS. roll over protection system
HOC. height-of-cut	SFH. slotted fillister head
HSBH. hex socket button head	SHH. slotted hex head
HSFH. hex socket flat head	SHWH. slotted hex washer head
HSH. hex socket head	SPH. slotted pan head
HWH. hex washer head	

Footnotes

❶ Not illustrated

❷ Not serviced separately

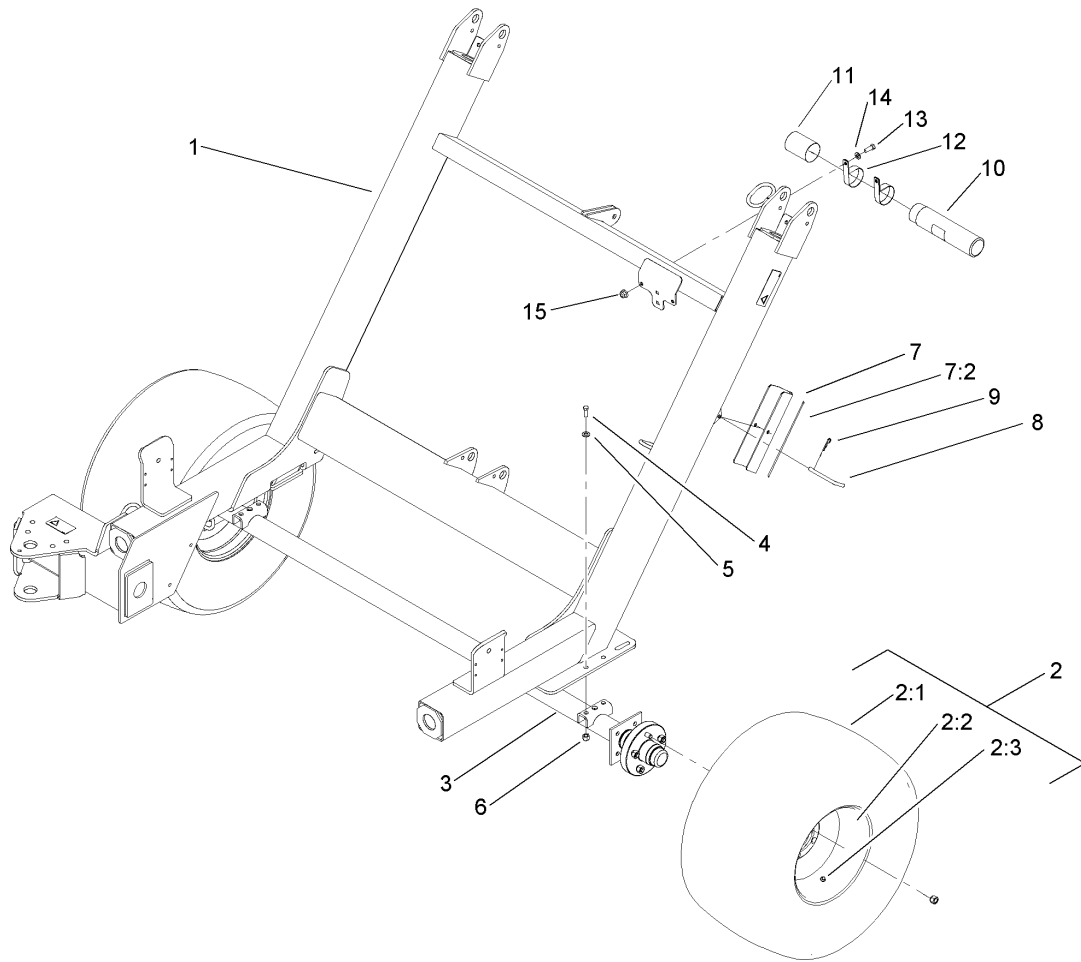

Main Frame and Axle Assembly

Ref	Part No.	Qty.	Description
1	108-0776	1	Frame-Main
2	107-1459	2	Wheel And Tire ASM
2:1	93-6152	1	Tire
2:2	107-1461	1	Rim
2:3	232-24	1	Stem-Valve
3	107-1529	1	Trailer Axle ASM
4	324-5	4	Screw-HH
5	3256-25	8	Washer-Flat
6	3296-48	4	Nut-Lock, NI
7	108-0777	1	Stop-Cylinder
7:2	93-9852	1	Decal-Warning
8	63-7880	1	Pin-Latch, Brake
9	3290-250	1	Pin-Hair
10	104-7050	1	Housing-Manual
11	104-7048	1	Cap-Housing
12	2412-133	2	R-Clamp
13	323-6	2	Screw-HH
14	3256-24	2	Washer-Flat
15	104-8301	2	Nut-Flange, NI

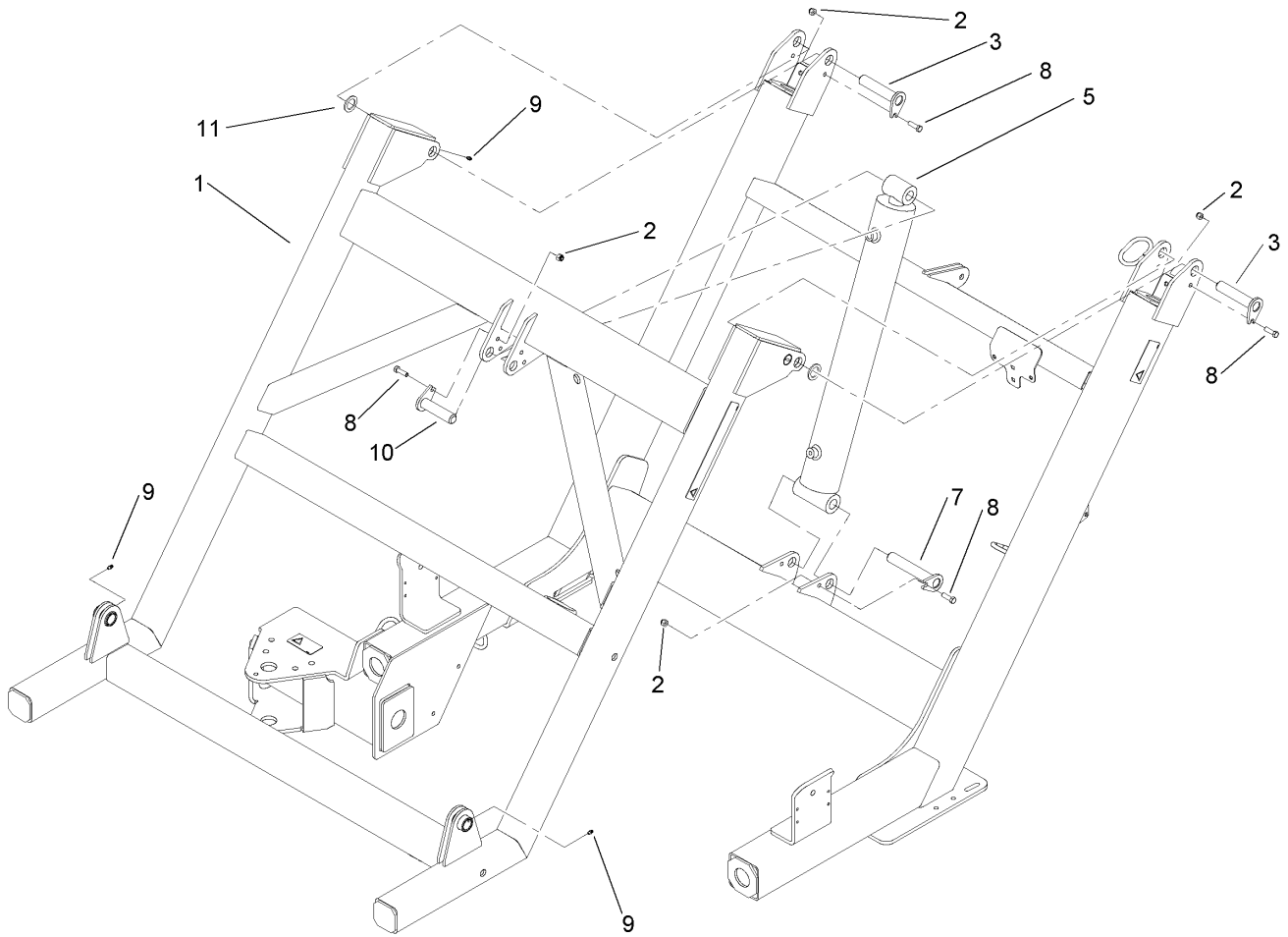

Pitch Frame and Cylinder Assembly

Ref	Part No.	Qty.	Description
1	108-0778	1	Frame-Pitch
2	104-8301	4	Nut-Flange, NI
3	107-1258	2	Pin-Flag
5	107-1310	1	Cylinder-Hydraulic
7	108-0669	1	Pin-Flag
8	323-7	4	Screw-HH
9	302-5	4	Fitting-Grease
10	108-0826	1	Pin-Flag
11	92-7845	2	Spacer-Hardened

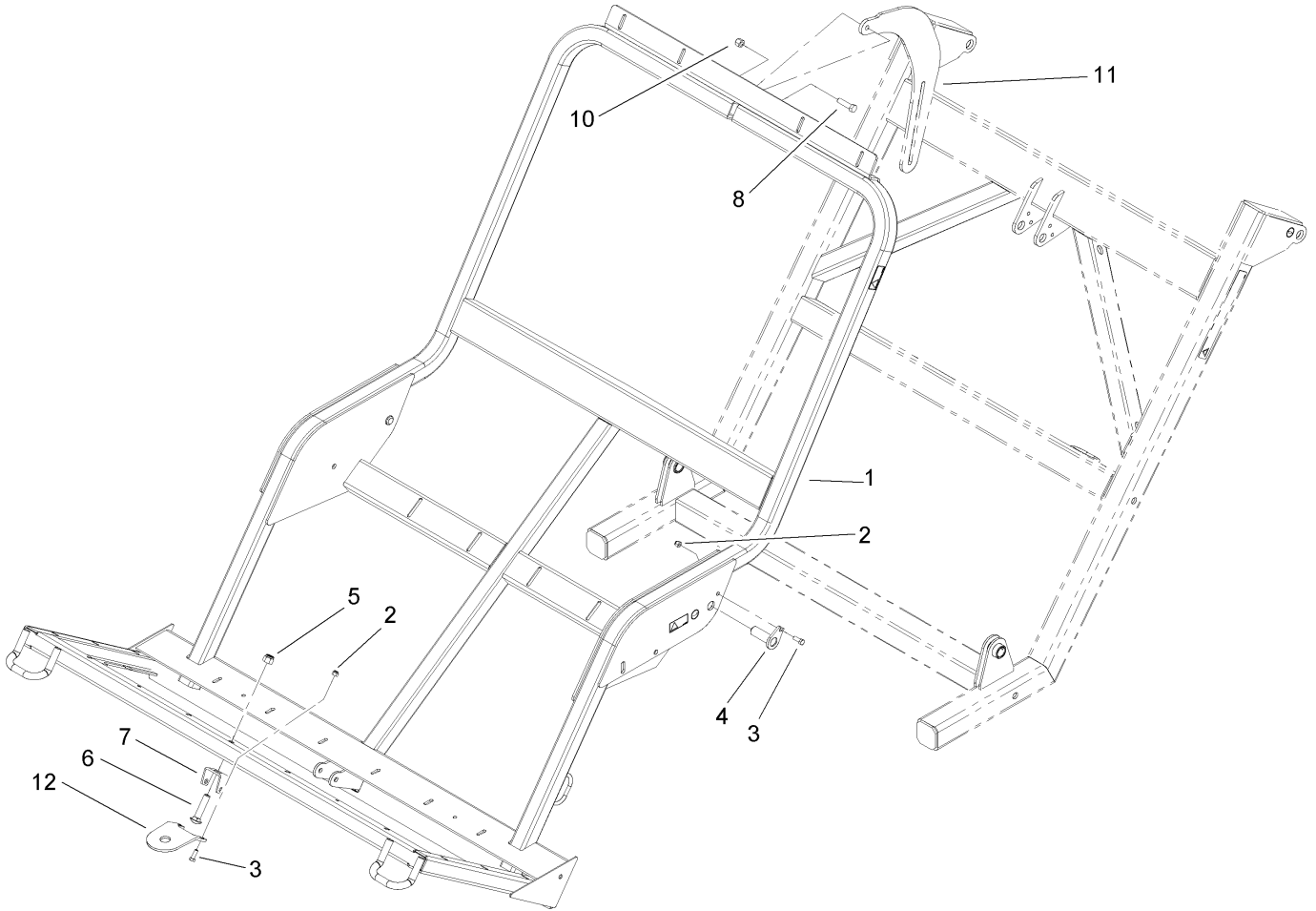

Saddle Frame Assembly

Ref	Part No.	Qty.	Description				
1	108-0779	1	Saddle				
2	104-8301	4	Nut-Flange, NI				
3	323-6	4	Screw-HH				
4	108-0657	2	Pin-Flag				
5	3296-53	1	Nut-Lock, NI				
6	3233-32	1	Bolt-Carriage				
7	107-1458-03	1	Pivot-Saddle				
8	325-7	2	Screw-HH				
10	3296-23	2	Nut-Lock, NI				
11	108-0759-01	1	Link				
12	107-1327-03	1	Plate-Hook, Tow				

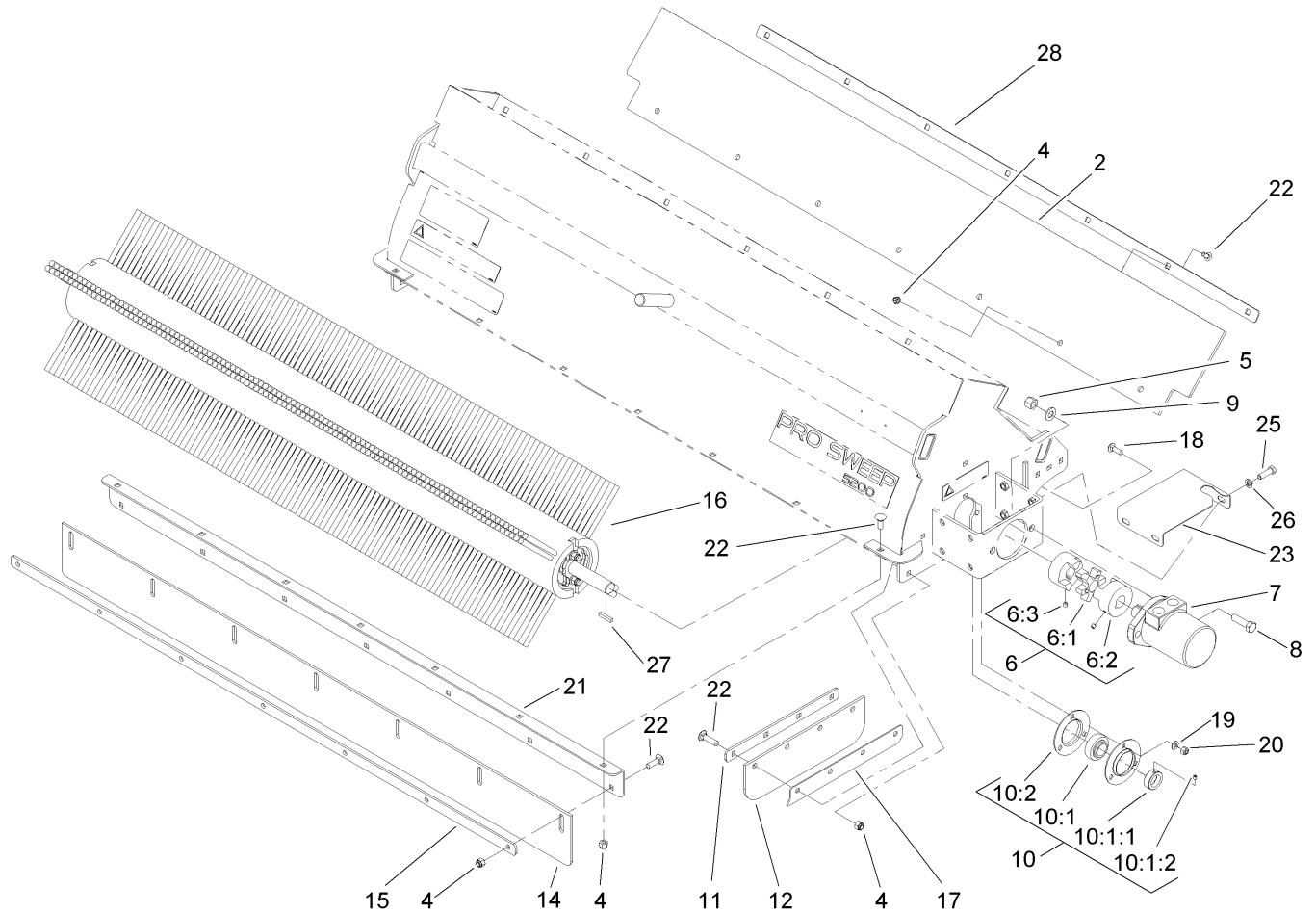

Brush, Motor and Shield Assembly

Ref	Part No.	Qty.	Description
2	108-0686	1	Shield-Rubber, Top
4	104-8301	29	Nut-Flange, NI
5	3296-23	2	Nut-Lock, NI
6	108-0760	1	Coupling-Jaw, Stock
6:1	108-0761	1	Spider-Coupling
6:2	108-0762	2	Coupling-Jaw
6:3	3246-2	4	Screw-Set, HSH
7	105-9455	1	Motor
8	325-7	2	Screw-HH
9	3256-26	2	Washer-Flat
10	107-1471	2	Bearing-Flange, 3-Bolt
10:1	107-1472	1	Bearing
10:1:1	251-77	1	Lockcollar-Bearing
10:1:2	3245-35	1	Screw-Hs
10:2	107-1474	2	Flange-3 Bolt
11	108-0668-03	2	Plate-Skirt, Side
12	108-0683	2	Shield-Rubber, Side
14	107-1302	1	Shield-Rubber, Front
15	108-0667-03	1	Plate-Skirt, Front
16	107-1452	1	Brush ASM
17	107-1439-03	2	Plate-Angle
18	3230-2	6	Bolt-CARR
19	3256-23	6	Washer-Flat
20	3296-29	6	Nut-Lock, NI

Ref	Part No.	Qty.	Description
21	107-1280-01	1	Angle-Front
22	3231-25	29	Screw-CARR
23	108-0781	2	Cover-Coupler
25	323-6	8	Screw-HH
26	3253-21	8	Washer-Lock
27	13-2840	1	Key-Square
28	108-0844-03	1	Plate-Shield, Top

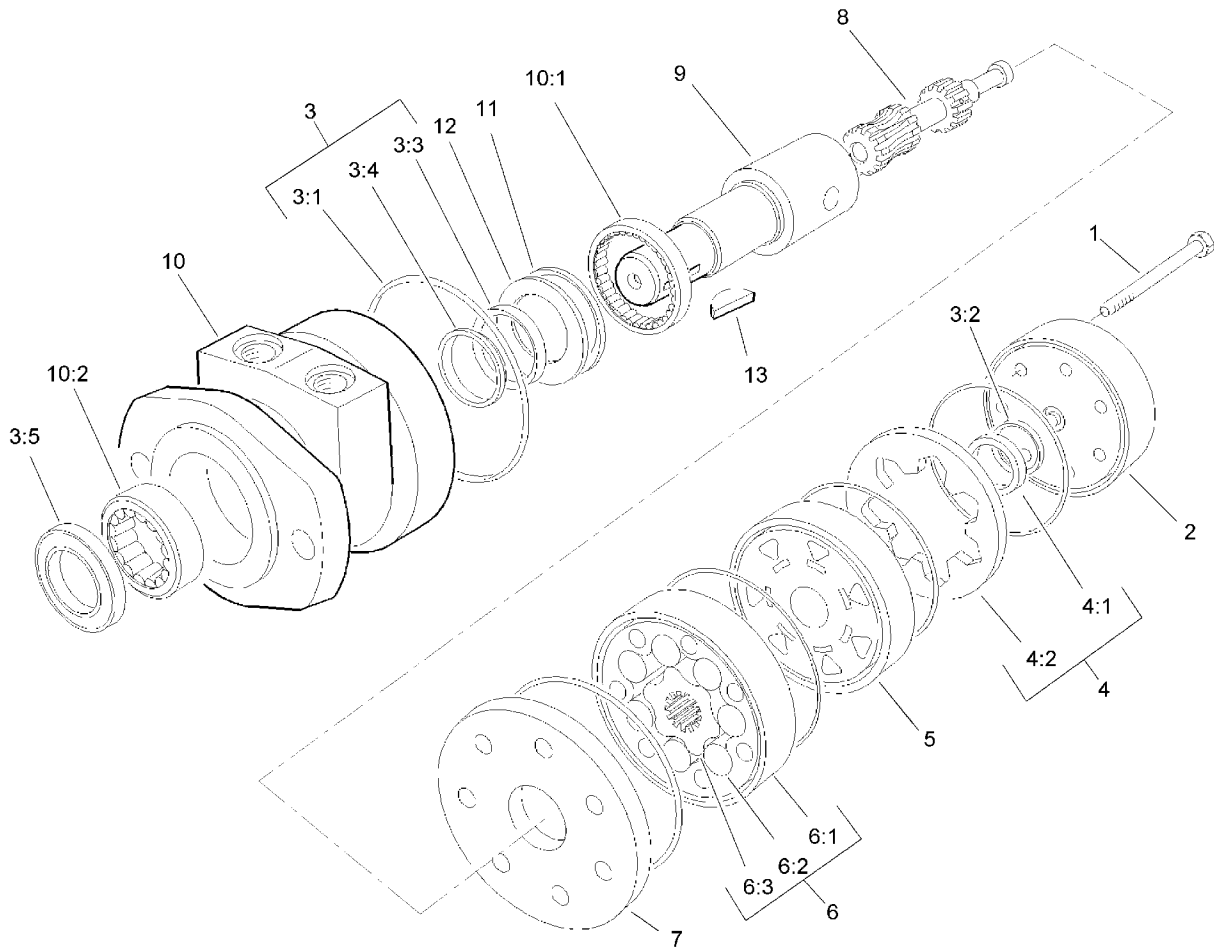

Hydraulic Motor Assembly No. 105-9455

Ref	Part No.	Qty.	Description
1	322-33	5	Screw-HH
2	106-1981	1	Cover-End
3	106-1989	1	Seal Kit
②3:1		6	Seal-Ring
②3:2		1	Seal-Commutator
②3:3		1	Seal-Dirt And Water
②3:4		1	Washer-Backup
②3:5		1	Seal-Shaft
①②3:6		1	Ring-Back Up
4	106-1982	1	Commutator ASM
②4:1		1	Commutator
②4:2		1	Ring-Commutator
5	106-1983	1	Manifold
6	106-1984	1	Rotor Set
②6:1		1	Stator
②6:2		7	Vane
②6:3		1	Rotor
7	106-1985	1	Plate-Wear
8	106-1986	1	Link-Drive
9	106-1987	1	Shaft-Coupling
10	106-1988	1	Housing ASM
②10:1		1	Bearing
②10:2		1	Bearing
②11		1	Bearing-Thrust

Ref	Part No.	Qty.	Description
②12		1	Washer-Thrust
13	106-1990	1	Key-Woodruff

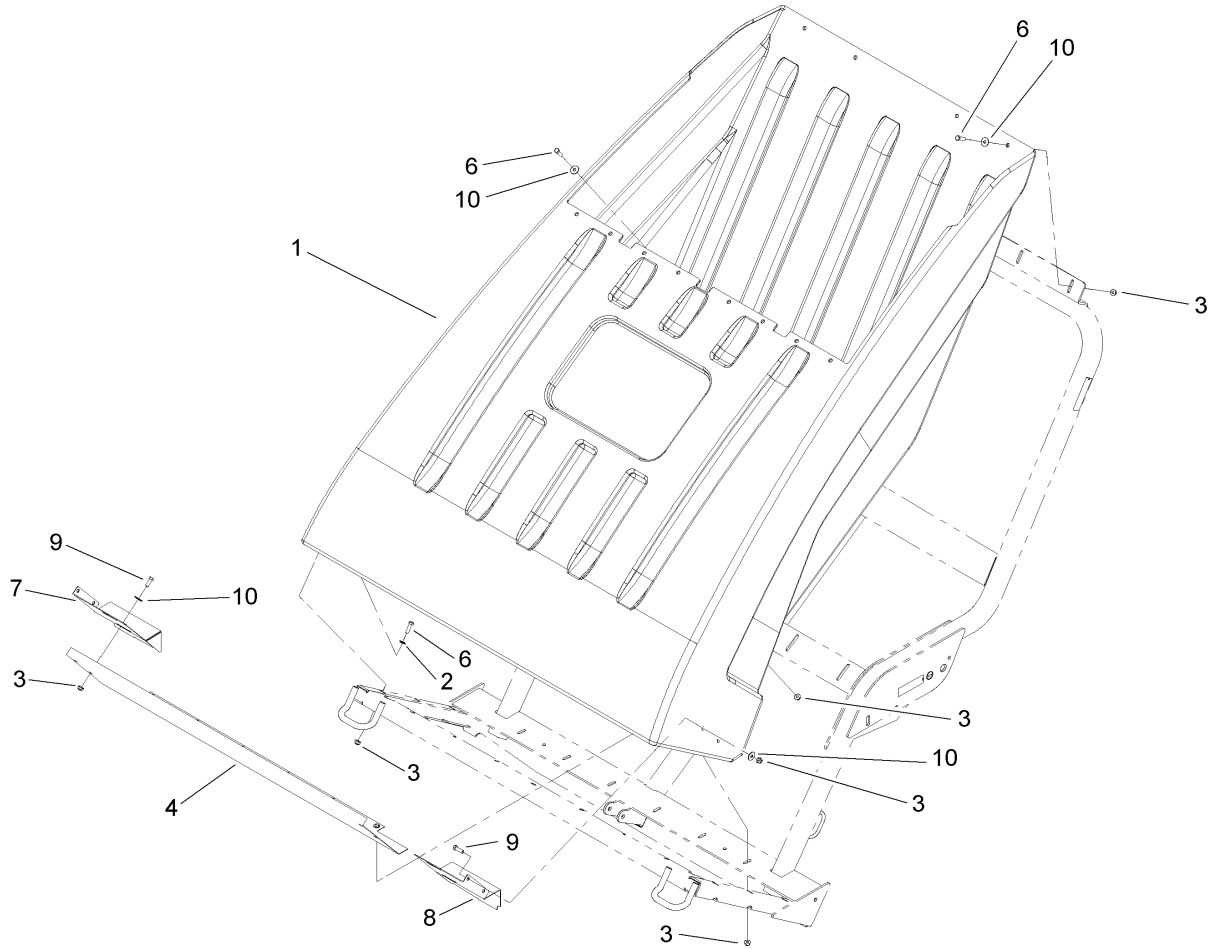

Hopper Assembly

Ref	Part No.	Qty.	Description
1	107-1272	1	Hopper-Dump
2	3256-24	13	Washer-Flat
3	104-8301	34	Nut-Flange, NI
4	107-1225-03	1	Baffle-Hopper
6	323-7	21	Screw-HH
7	107-1462-03	1	Plate-Side, Baffle LH
8	107-1442-03	1	Plate-Side, Baffle RH
9	323-6	8	Screw-HH
10	3256-35	13	Washer-Flat

--	--	--	--

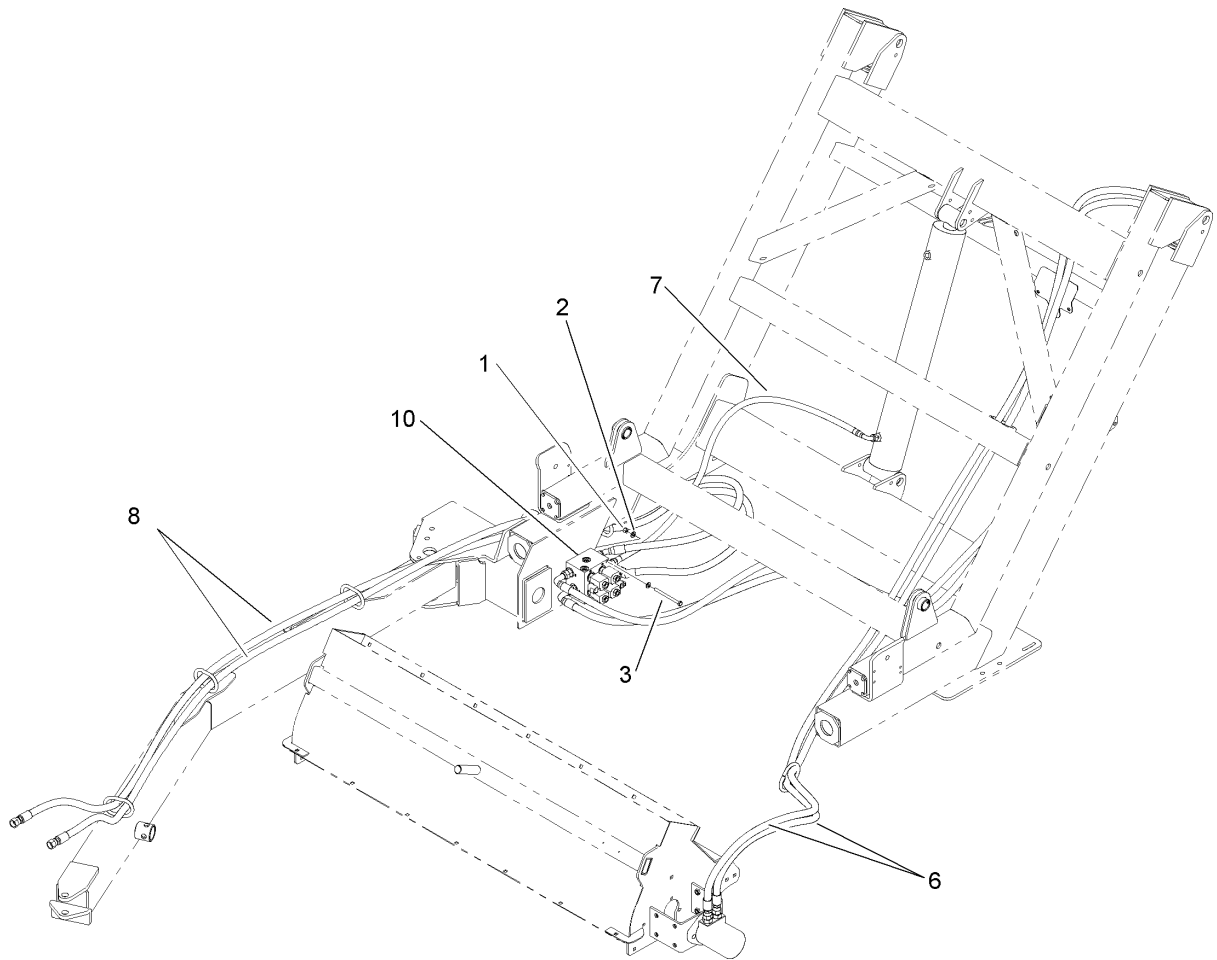

Hose Assembly

Ref	Part No.	Qty.	Description				
1	3296-29	2	Nut-Lock, NI				
2	3256-23	4	Washer-Flat				
3	322-19	2	Screw-HH				
6	107-1394	2	HYD Hose ASM				
7	107-1396	1	HYD Hose ASM				
8	107-1395	2	HYD Hose ASM				
10	107-1400	1	Block-Manifold				

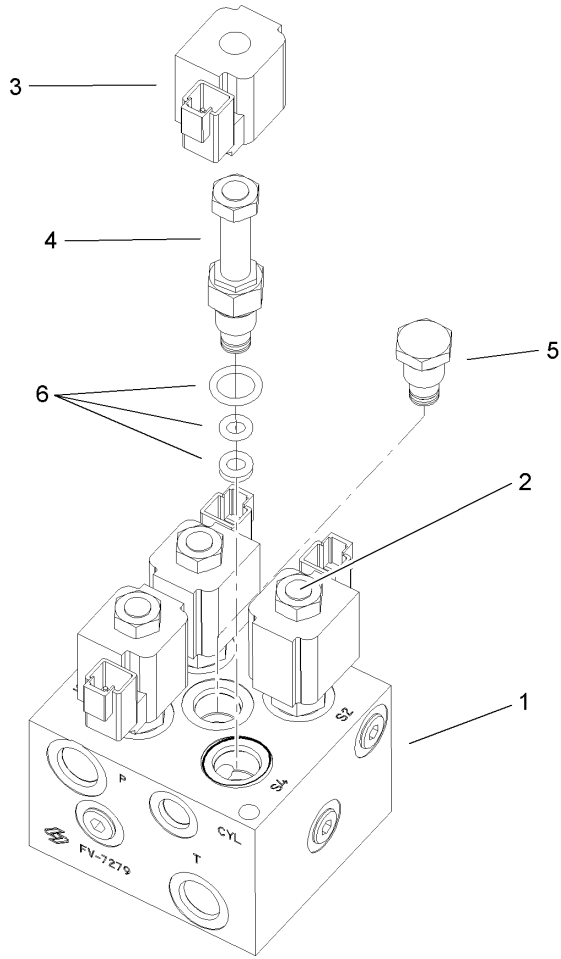

Manifold Block Assembly No. 107-1400

Ref	Part No.	Qty.	Description
1		1	Valve Body
2	108-2884	1	Valve-Solenoid
3	108-2885	4	Receptacle-Deutsch, 12 Vdc
4	108-2886	3	Valve-Solenoid
5	108-2887	1	Valve-Check
6	95-1232	4	Kit-Seal, Valve

--	--	--	--

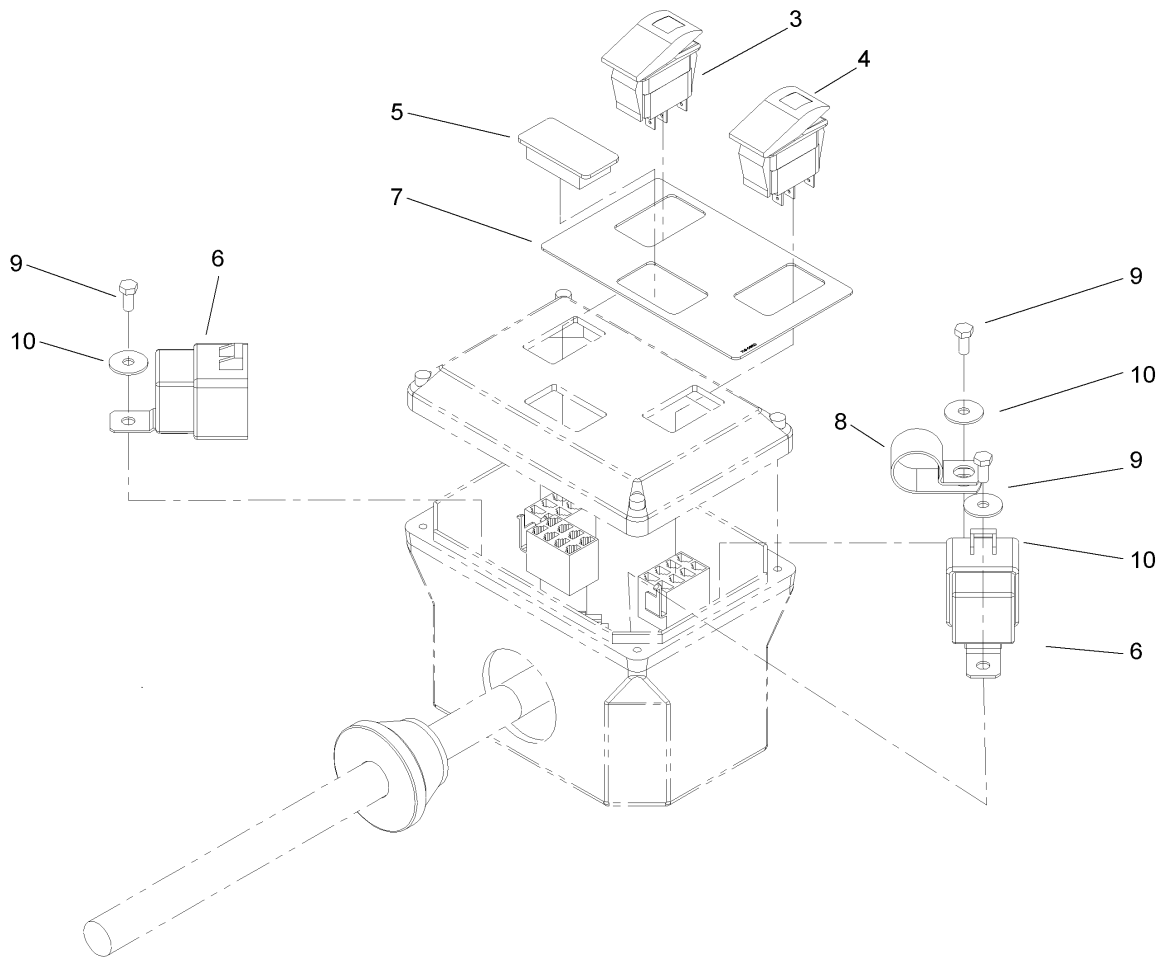

Remote Control Box Assembly No. 107-1382

Ref	Part No.	Qty.	Description				
3	108-0859	1	Switch				
4	105-4232	1	Switch				
5	99-7420	1	Plug-Hole				
6	99-7430	2	Relay				
7	108-0860	1	Decal-Electric Control Box				
8	2412-41	1	Clamp				
9	25-8640	3	Screw-HH				
10	3256-61	3	Washer-Flat				

Attachments and Accessories

For 07065 - Pro Sweep 5200

Product Name	Model/Part
Brake Kit	07086
Windrow Kit	07087
Electric Offset Arm	07088
Jack ASM	106-9699
Wheel Scraper Kit	107-1370
Slow-Moving Vehicle Sign Kit	107-1372
Side Mirror Kit	107-8048
Pin-Hitch, Pointed	13-6200
Rear View Mirror Kit	92-2670

NOTES

