



## Super Recycler<sup>®</sup> Lawn Mower

Model No. 20054 - 260000001 and up.

### Parts Catalog

---

#### Ordering Replacement Parts

To order replacement parts, please supply the part number, the quantity, and the description of each part desired.

#### Understanding Reference Numbers

Each identified part in an illustration has a reference number. The reference number for a part also appears in the parts list, along with other information about the part.

This catalog uses two special reference number formats, one to indicate parts in a service assembly and another to indicate the quantity of a given part in an illustration.

#### Service Assembly Reference Numbers

Parts in service assemblies have reference numbers in the form a:b. The a represents the reference number of the entire service assembly and the b represents a sequential number unique to each part within the service assembly.

For example, a wheel assembly might be identified by reference number 6, the tire by 6:1, the valve by 6:2, and the wheel by 6:3. When you order the assembly identified by reference number 6, you receive all parts identified by reference numbers 6:1, 6:2, and 6:3. However, you may also order any part individually. Reference numbers of this type appear in illustrations and in part lists.

#### Reference Numbers Indicating Quantity

In an illustration, if a reference number indicates more than one part, the reference number has the form nX y. The n represents the quantity of the part, the X is the multiplication symbol, and the y represents the reference number.

For example, in an illustration, the reference number 2X 37 means that two of the parts identified by reference number 37 are indicated.

# Contents

Description	Page	Description	Page
Housing Assembly	..... 3	Air Cleaner Assembly Briggs and Stratton	
Housing Assembly No. 108-4750	..... 4	125K02-0189-E1	..... 14
Height-of-Cut Assembly	..... 5	Governor Assembly Briggs and Stratton	
Transmission Assembly	..... 6	125K02-0189-E1	..... 15
Gear Case Assembly No. 108-8140	..... 7	Muffler and Fuel Tank Assembly Briggs and	
Engine Assembly	..... 8	Stratton 125K02-0189-E1	..... 16
Handle Assembly	..... 9	Blower Housing Assembly Briggs and Stratton	
Cylinder Assembly Briggs and Stratton		125K02-0189-E1	..... 17
125K02-0189-E1	..... 10	Starter Assembly Briggs and Stratton 125K02-	
Crankshaft Assembly Briggs and Stratton		0189-E1	..... 18
125K02-0189-E1	..... 11	Engine Gasket Set Assembly Briggs and	
Crankcase Assembly Briggs and Stratton		Stratton 125K02-0189-E1	..... 19
125K02-0189-E1	..... 12	Carburetor Overhaul Kit and Gasket Set	
Carburetor Assembly Briggs and Stratton		Assemblies Briggs and Stratton 125K02-0189-	
125K02-0189-E1	..... 13	E1	..... 20
		Attachments and Accessories List	..... 21

## Part Description Abbreviations

Part descriptions in this catalog may include the following abbreviations.

AR. .... as required	INC. .... incorporated
ASM. .... assembly	LH. .... left hand
BBC. .... blade brake clutch	NI. .... nylon insert
CARR. .... carriage	NPTF. .... national pipe thread fine
DEG. .... degrees	PFH. .... phillips flat head
EXT. .... external	PPH. .... phillips pan head
FH. .... flat head	PPHTF. .... phillips pan head thread
GA. .... gauge	forming
HF. .... hex flange	PRH. .... phillips round head
HH. .... hex head	PTH. .... phillips truss head
HHF. .... hex head flange	PTO. .... power-take-off
HHFTF. .... hex head flange thread forming	RH. .... right hand
HJ. .... hex jam	ROPS. .... roll-over-protection-system
HLH. .... hex lag head	SFH. .... slotted fillister head
HOC. .... height-of-cut	SHH. .... slotted hex head
HSBH. .... hex socket button head	SHWH. .... slotted hex washer head
HSFH. .... hex socket flat head	SPH. .... slotted pan head
HSH. .... hex socket head	SQH. .... square head
HWH. .... hex washer head	SRH. .... slotted round head
HWHTF. .... hex washer head thread	STD. .... standard
forming	TAP. .... self tapping
HYD. .... hydraulic	TTH. .... torx truss head

## Footnotes

- |   |                                   |
|---|-----------------------------------|
| ❶ Not illustrated                                 | ❷ Not serviced separately         |
| ❸ Obtain from your local Briggs & Stratton dealer | ❹ For use only on Models with BBC |

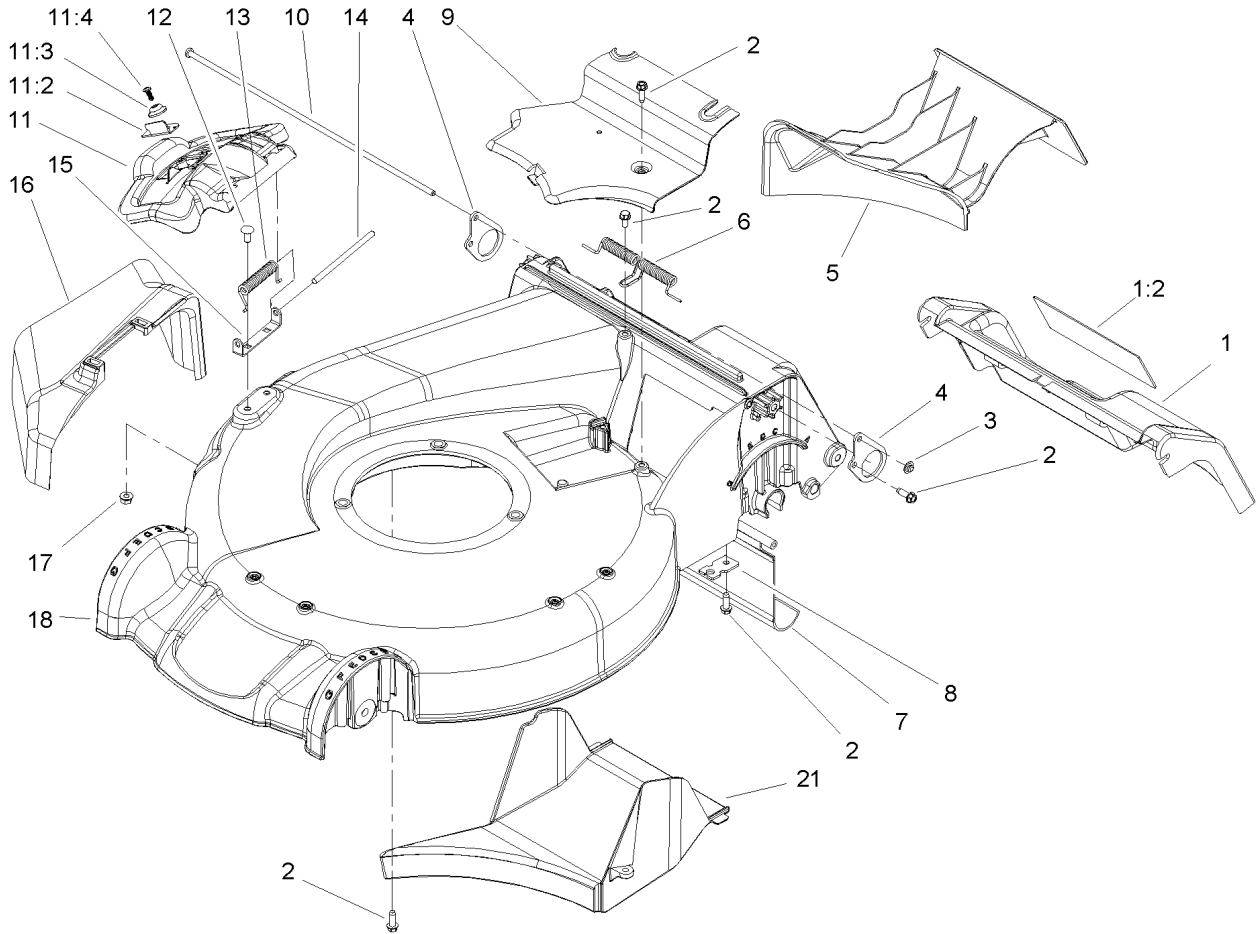

## Housing Assembly

Ref	Part No.	Qty.	Description
1	105-1323	1	Rear Door ASM
1:2	105-1295	1	Decal-Warning
2	49-2040	7	Screw-HWHTF
3	3290-337	1	Nut-Speed
4	107-7493	2	Plate-Support, Door
5	107-7490	1	Plug-Mulch
6	105-3032	1	Spring-Door, Rear
7	107-7496	1	Shield-Trailing
8	107-7497	1	Bracket-Cable, Traction
9	107-7494	1	Cover-Belt
10	107-7499	1	Rod-Support, Door
11	107-3717	1	Discharge Door ASM
11:2	107-0795	1	Latch-Door
11:3	107-7456	1	Cap-Door
11:4	107-7461	1	Screw-Plastite
12	3229-11	2	Screw-CARR
13	99-5293	1	Spring-Torsion
14	99-5291	1	Rod-Cover
15	99-5292	1	Bracket-Cover
16	108-3753	1	Chute-Discharge, Side
17	32128-32	2	Nut-HHF
18	108-4750	1	Housing ASM
21	107-7495	1	Tunnel-Discharge

--	--	--	--

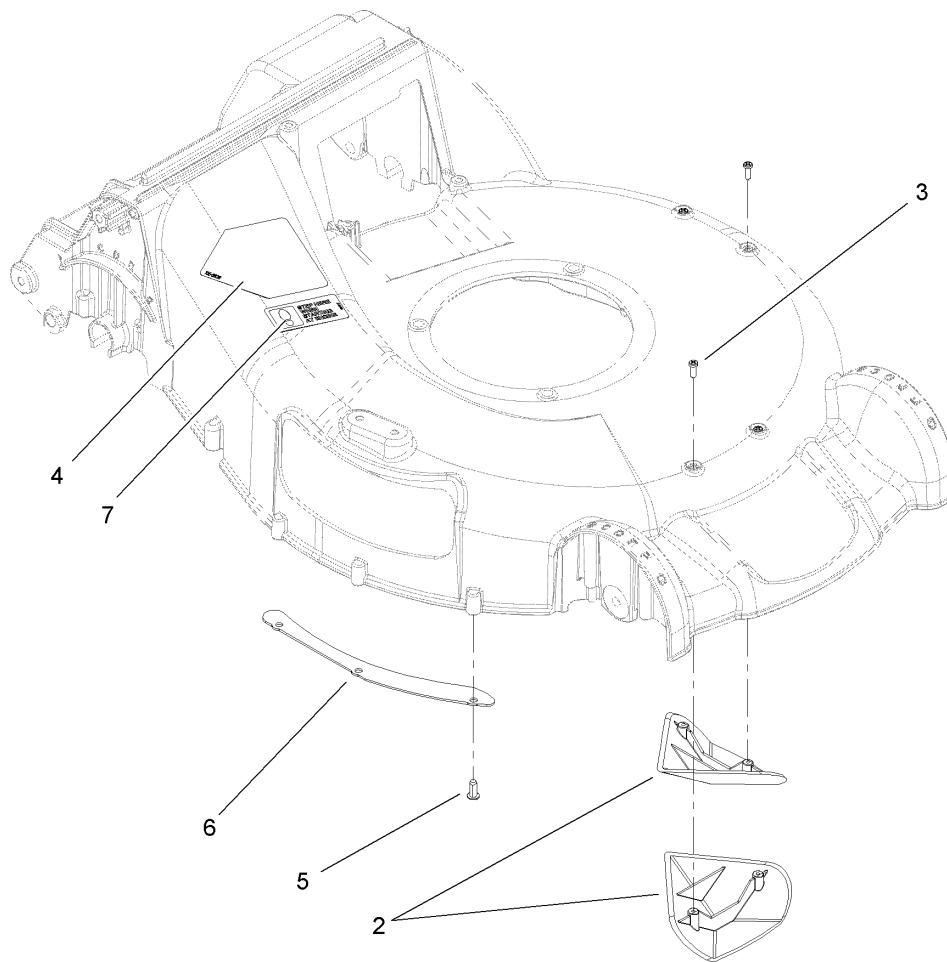

### Housing Assembly No. 108-4750

Ref	Part No.	Qty.	Description
2	108-3798	2	Kicker-Housing
3	32144-111	4	Screw-PPH
4	105-6838	1	Decal-Danger
5	63-8590	3	Screw
6	105-1316-03	1	Sheet-Lip
7	108-8117	1	Decal-Foot Placement



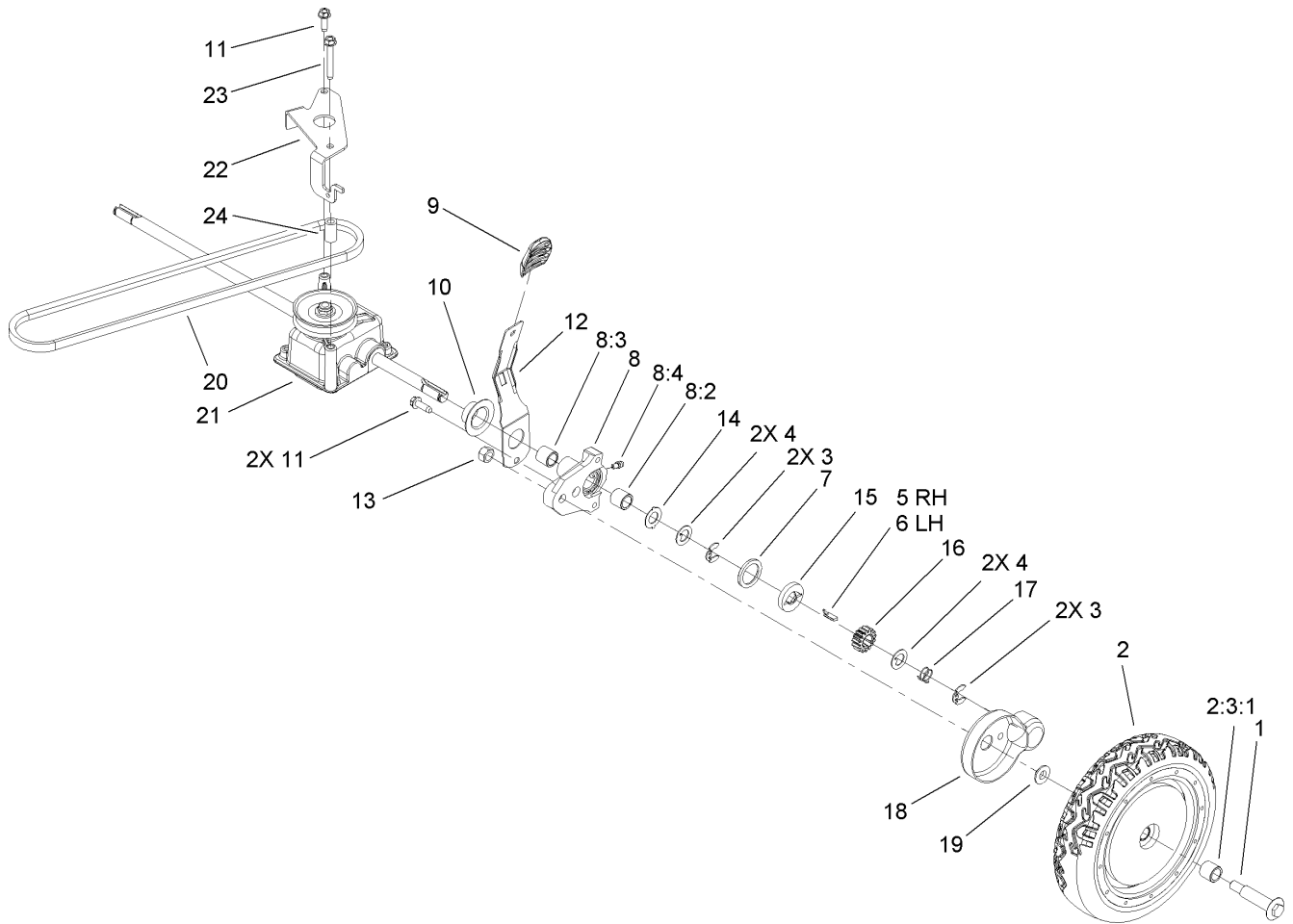

## Transmission Assembly

Ref	Part No.	Qty.	Description
1	92-1057	2	Bolt-Shoulder
2	107-3709	2	Wheel Gear ASM
1 2 2:3		1	Wheel ASM
2:3:1	27-6250	2	Bushing
3	65-2720	4	Klipring-Locking
4	65-4740	4	Washer-Thrust, Keyed
1 5	66-6040	1	Key-Rocking, RH
6	66-6050	1	Key-Rocking, LH
7	65-4710	2	Ring-Friction
8	100-8774	2	Pivot Arm ASM
8:2	47-2900	1	Bushing
8:3	70-9760	1	Bushing
8:4	302-56	1	Fitting-Grease
9	105-3042	2	Knob-Lever, HOC
10	42-3520	2	Cap-End
11	49-2040	3	Screw-HWHTF
12	107-7491	2	Spring Arm
13	603773	2	Nut
14	65-4730	2	Washer-Arm, Pivot
15	65-4760	2	Washer-Clutch
16	65-4750	2	Gear-Pinion
17	65-4720	2	Spring-Compression
18	74-1660	2	Cover-Wheel
19	74-1671	2	Spacer-Cover, Wheel

Ref	Part No.	Qty.	Description
20	99-1597	1	V-Belt
21	108-8140	1	Gear Case ASM
22	107-7483-03	1	Bracket-Gearbox
23	92-1616	1	Screw-HWHTF
24	614673	1	Bushing-Plate, Actuator

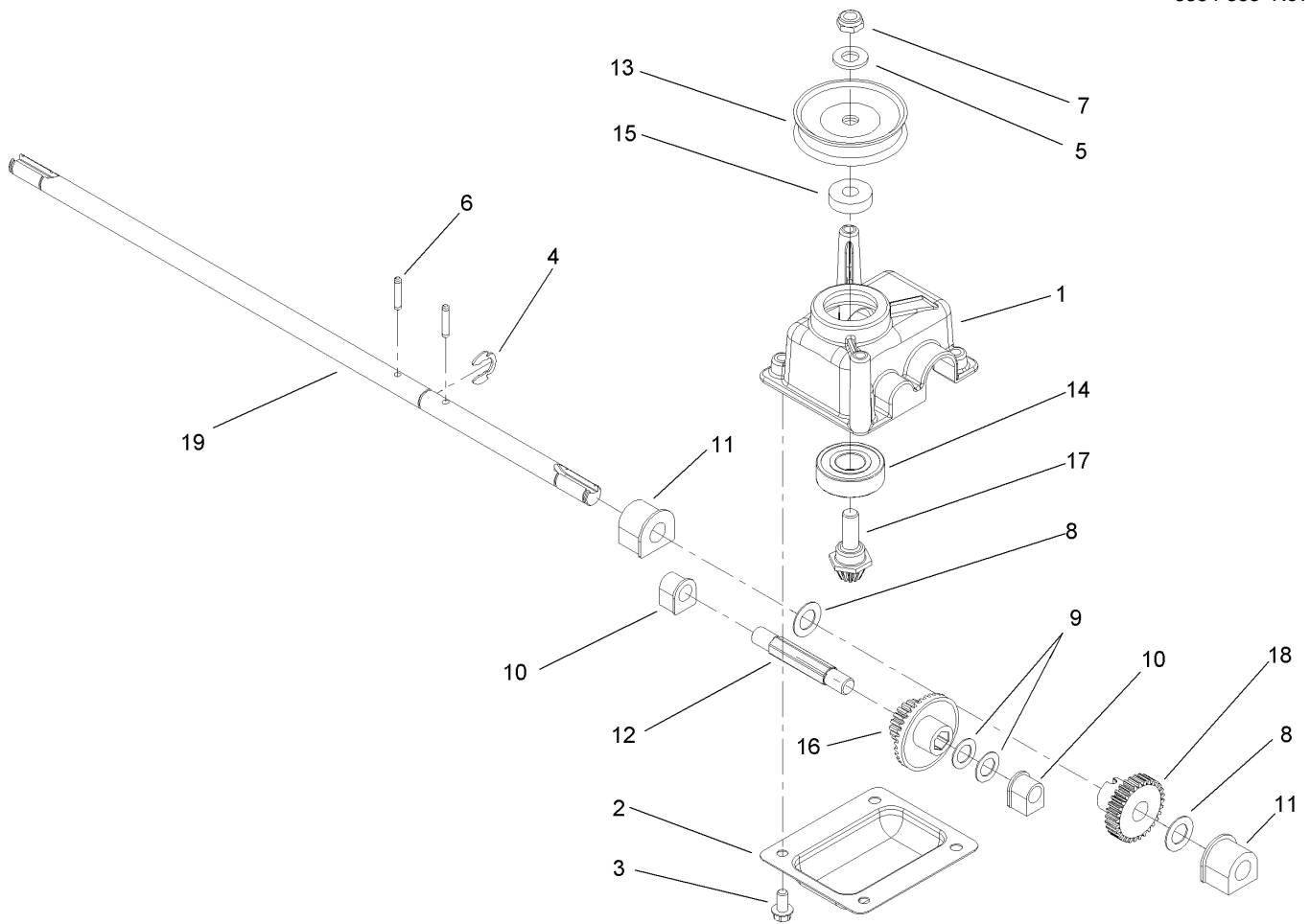

## Gear Case Assembly No. 108-8140

Ref	Part No.	Qty.	Description
1	104-7619	1	Case-Gear
2	614668-03	1	Cover-Case, Gear
3	32144-4	4	Screw-HWH
4	32151-68	1	Ring-Retaining
5	3256-24	1	Washer-Flat
6	3285-19	2	Pin-Groove
7	3296-5	1	Nut-Lock
8	36-4780	2	Washer
9	36-4791	2	Washer-Thrust
10	60-8750	2	Bushing
11	60-8850	2	Bushing
12	614696	1	Shaft-Intermediate
13	100-1176	2	Pulley-Half
14	100-1048	1	Bearing-Ball
15	62-6660	1	Spacer
16	104-1005	1	Gear-19T Spur, 37T Bevel
17	104-7667	1	Gear-Pinion, Bevel
18	104-1004	1	Gear-30T
19	108-8141	1	Shaft-Output

--	--	--	--

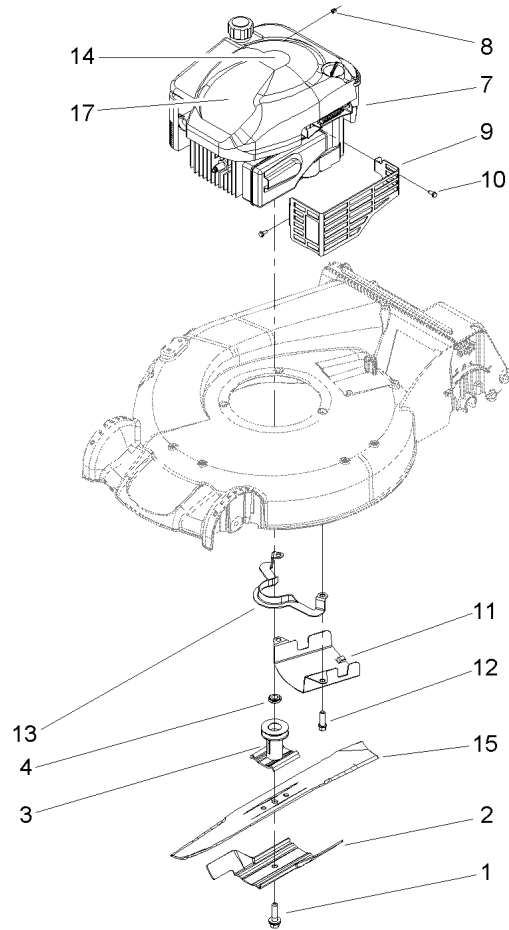

## Engine Assembly

Ref	Part No.	Qty.	Description				
1	105-8579	1	Bolt-Blade				
2	105-6848-03	1	Accelerator-Blade				
3	106-3987	1	Blade Driver ASM				
4	106-3999	1	Spacer-Driver				
2 27		1	Engine-Briggs And Stratton, 125K02-0189-E1				
8	2210-316	1	Stop-Rope Need Order				
9	104-7577-03	1	Shield-Muffler				
10	32144-1	3	Screw-Taptite				
11	107-7489-03	1	Shield-Grass				
12	95-1727	3	Screw-Taptite				
13	108-8110-03	1	Guide-Belt				
14	108-8130	1	Decal-Recoil				
15	108-3762-03	1	Blade-Recycling				
17	108-9774	1	Decal				

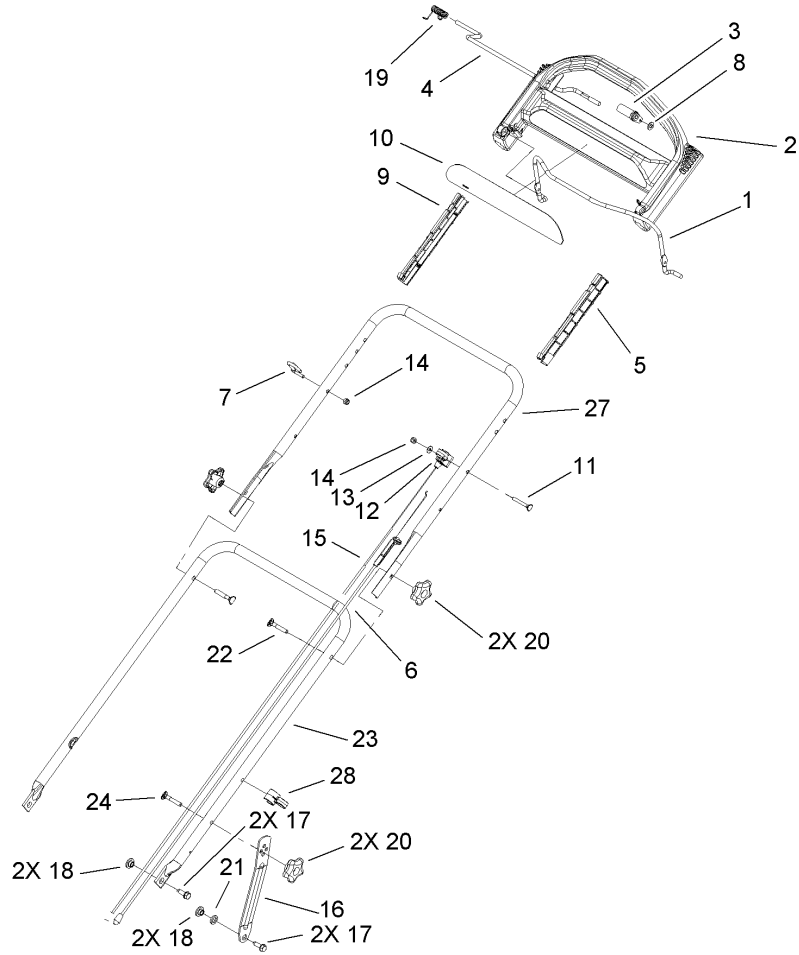

## Handle Assembly

Ref	Part No.	Qty.	Description
1	104-8679-03	1	Bail-Brake
2	104-8678	1	Handle-Control
3	99-1589	1	Lever-Traction
4	99-1588	1	Bar-Control, Traction
5	105-6842	1	Guide-LH
6	108-8157	1	Cable-Brake
7	86-9671	1	Guide-Rope
8	3256-23	1	Washer-Flat
9	105-6841	1	Guide-RH
10	108-8134	1	Decal-Handle
11	95-4453	1	Screw
12	99-5239	1	Anchor-Cable
13	3256-1	1	Washer-Flat
14	3296-73	2	Nut-Lock, NI
15	108-8158	1	Cable-Traction
16	108-8145-03	2	Support-Handle
17	701243	4	Screw-HWHTF
18	27-6600	4	Spacer-Coupling
19	104-8690	1	Spring-Torsion
20	108-8162	4	Knob-Locking
21	55-9670	2	Washer
22	92-2260	2	Screw-Handle
23	107-7476-05	1	Handle-Lower
24	92-2260	2	Screw-Handle

Ref	Part No.	Qty.	Description
27	107-3783-05	1	Handle-Upper
28	106-6805	1	Guide-Cable

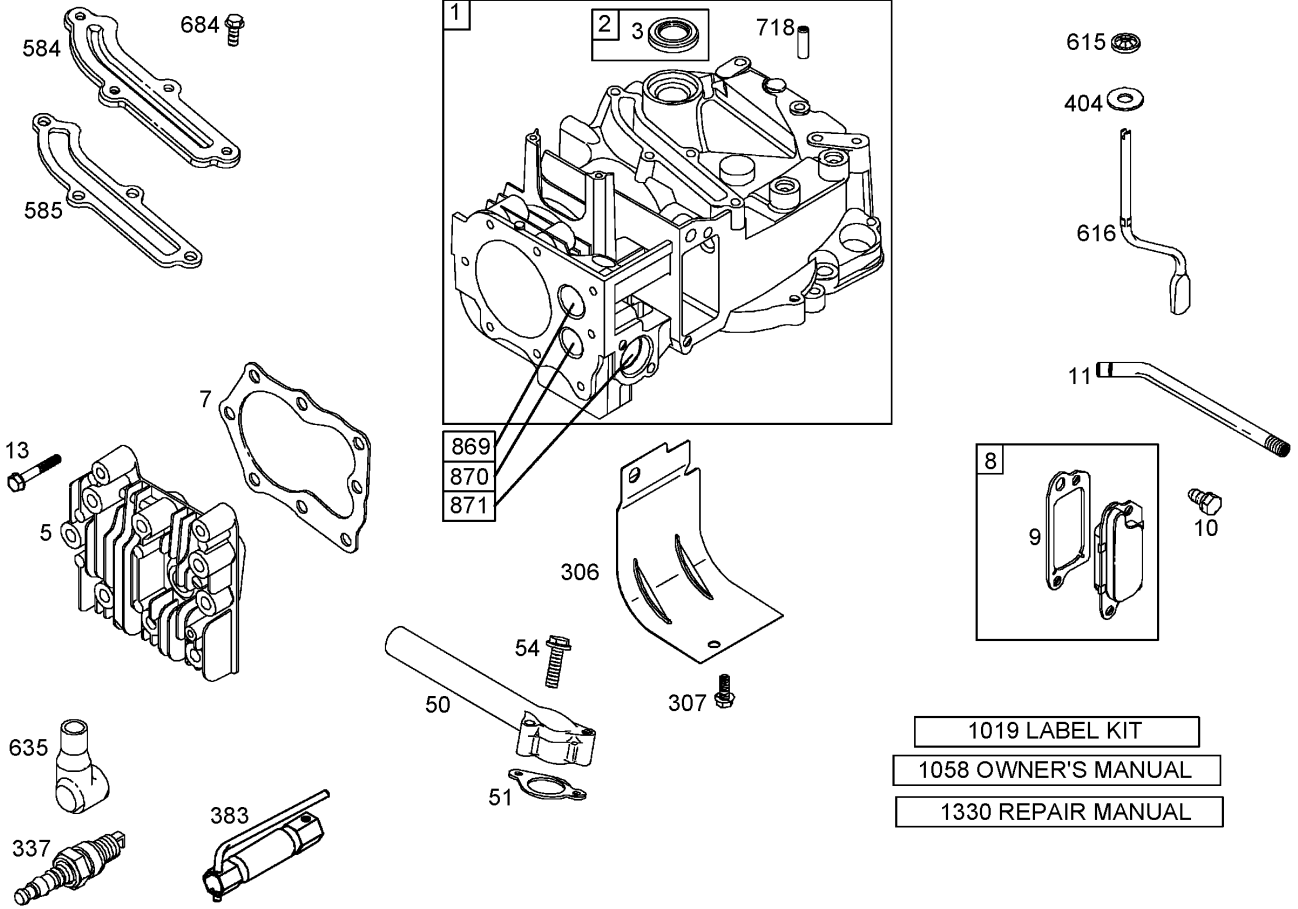

## Cylinder Assembly Briggs and Stratton 125K02-0189-E1

Ref	Part No.	Qty.	Description
1	697322	1	Cylinder ASM
2	399269	1	Bushing/Seal Kit
3	299819	1	Seal-Oil (Magneto Side)
5	691160	1	Head-Cylinder
7	692249	1	Gasket-Head, Cylinder
8	695250	1	Breather ASM
9	699472	1	Gasket-Breather
10	691125	1	Screw (Breather Side)
11	691781	1	Tube-Breather
13	690912	1	Screw (Cylinder Head)
50	497465	1	Manifold-Intake
51	272199	1	Gasket-Intake
54	691650	1	Screw (Intake Manifold)
306	690450	1	Shield-Cylinder
307	690345	1	Screw (Cylinder Shield)
337	802592	1	Plug-Spark
383	89838	1	Wrench-Plug, Spark
404	690272	1	Washer (Governor Crank)
584	697734	1	Cover-Passage, Breather
585	691879	1	Gasket-Passage, Breather
615	690340	1	Retainer-Shaft, Governor
616	698801	1	Crank-Governor
635	66538	1	Boot-Plug, Spark
684	690345	1	Screw (Breather Passage Cover)

Ref	Part No.	Qty.	Description
718	690959	1	Pin-Locating
869	691155	1	Seat-Valve (Intake)
870	690380	1	Seat-Valve (Exhaust)
871	262001	1	Bushing-Guide (Exhaust)
871	63709	1	Bushing-Guide (Intake)
1019	494256	1	Label Kit
1058	275177	1	Manual-Owner's
1330	270962	1	Manual-Repair









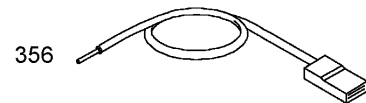
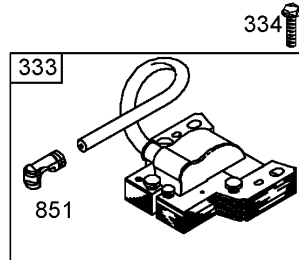
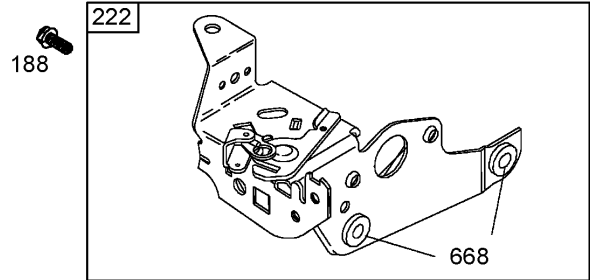
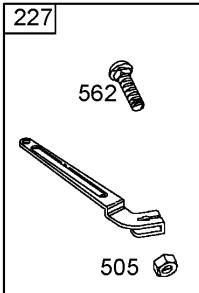
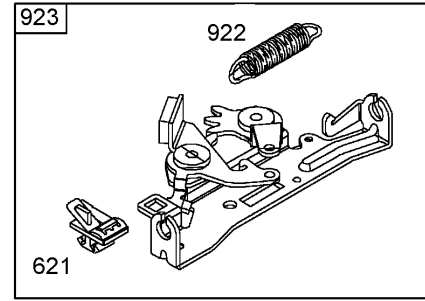
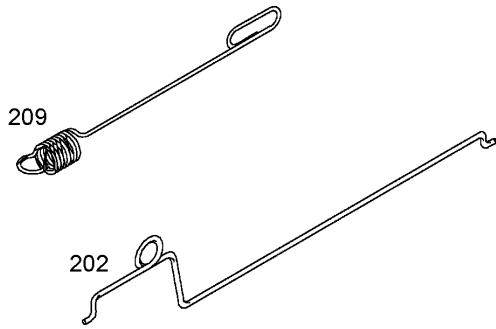

## Governor Assembly Briggs and Stratton 125K02-0189-E1

Ref	Part No.	Qty.	Description
●188	693399	1	Screw (Control Bracket)
●202	691829	1	Link-Governor, Mechanical
●209	691292	1	Spring-Governor
●222	791128	1	Bracket-Control
●227	690783	1	Lever-Control, Governor
●333	802574	1	Armature-Magneto
●334	691061	1	Screw (Magneto Armature)
●356	692390	1	Wire-Stop
●505	691251	1	Nut (Governor Control Lever)
●562	691119	1	Bolt (Governor Control Lever)
●621	692310	1	Switch-Stop
●668	493823	1	Spacer
●745	691648	1	Screw (Brake)
●851	493880	1	Terminal-Spark Plug
●922	691831	1	Spring-Brake
●923	691994	1	Brake ASM

--	--	--	--

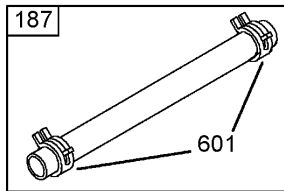
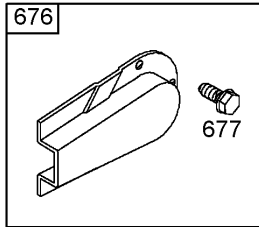
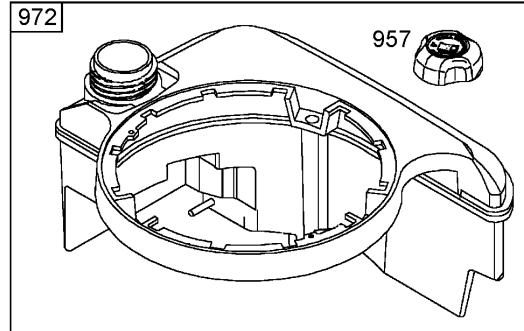
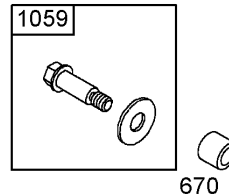
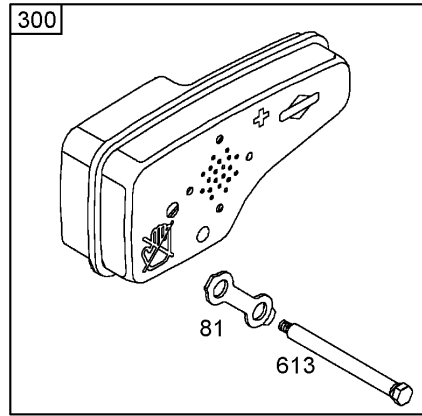

## Muffler and Fuel Tank Assembly Briggs and Stratton 125K02-0189-E1

Ref	Part No.	Qty.	Description
● 81	691740	1	Lock-Screw, Muffler
● 187	691050	1	Line-Fuel (Cut To Required Length)
● 190	690940	1	Screw (Fuel Tank)
● 300	692038	1	Muffler
● 601	95162	1	Clamp-Hose
● 613	691340	1	Screw (Muffler)
● 670	692294	1	Spacer-Tank, Fuel
● 676	493871	1	Deflector-Muffler
● 677	690661	1	Screw (Muffler Deflector)
● 957	692046	1	Cap-Tank, Fuel
● 972	699374	1	Tank-Fuel
● 1059	692311	1	Screw/Washer Kit

--	--	--	--

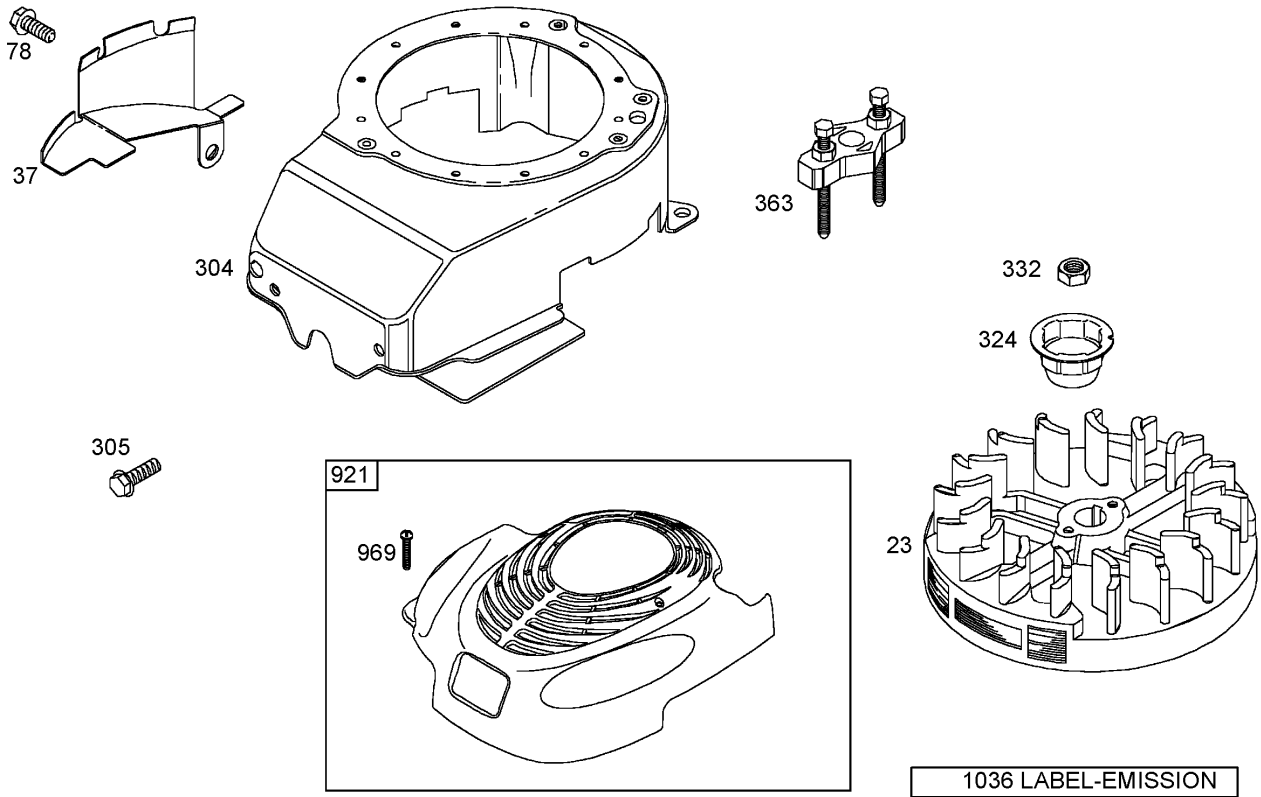

## Blower Housing Assembly Briggs and Stratton 125K02-0189-E1

Ref	Part No.	Qty.	Description
● 23	692315	1	Flywheel
● 37	694086	1	Guard-Flywheel
● 78	691108	1	Screw (Flywheel Guard)
● 304	493293	1	Housing-Blower
● 305	691108	1	Screw (Blower Housing)
● 324	695161	1	Cup/Screen ASM
● 332	690662	1	Nut (Flywheel)
● 363	19069	1	Puller-Flywheel
● 921	790036	1	Cover-Housing, Blower
● 969	691138	1	Screw (Blower Housing Cover)
● 1036	790411	1	Label-Emission





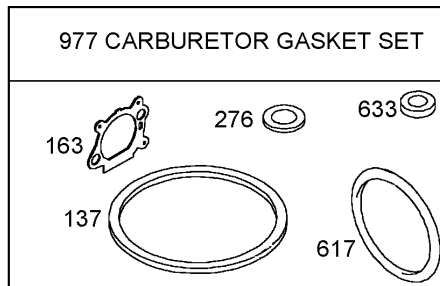
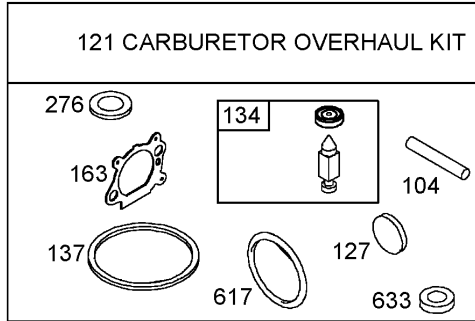

## Carburetor Overhaul Kit and Gasket Set Assemblies Briggs and Stratton 125K02-0189-E1

Ref	Part No.	Qty.	Description				
①104	691242	1	Pin-Hinge, Float				
①121	498260	1	Carburetor Overhaul Kit				
①127	694468	1	Plug-Welch				
①134	398188	1	Needle/Seat Kit				
①137	693981	1	Gasket-Bowl, Float				
①163	272653	1	Gasket-Cleaner, Air				
①276	271716	1	Washer-Sealing				
①617	270344	1	Seal-O Ring (Intake Manifold)				
①633	691321	1	Seal (Choke/Throttle Shaft)				
①977	498261	1	Carburetor Gasket Set				

# Attachments and Accessories

For 20054 - Super Recycler Lawn Mower

Product Name

Model/Part

Blade-Bagging .....	108-3759-03
Traction Assist Handle Kit .....	108-8120

# NOTES

# NOTES

