



40 Inch Tiller Compact Utility Loader

Model No. 22445 - 260000001 and up.

Parts Catalog

Ordering Replacement Parts

To order replacement parts, please supply the part number, the quantity, and the description of each part desired.

Understanding Reference Numbers

Each Identified part in an illustration has a reference number. The reference number for a part also appears in the parts list, along with other information about the part.

This catalog uses two special reference number formats, one to indicate parts in a service assembly and another to indicate the quantity of a given part in an illustration.

Service Assembly Reference Numbers

Parts in service assemblies have reference numbers in the form a:b. The a represents the reference number of the entire service assembly and the b represents a sequential number unique to each part within the service assembly.

For example, a wheel assembly might be identified by reference number 6, the tire by 6:1, the valve by 6:2, and the wheel by 6:3. When you order the assembly identified by reference number 6, you receive all parts identified by reference numbers 6:1, 6:2, and 6:3. However, you may also order any part individually. Reference numbers of this type appear in illustrations and in part lists.

Reference Numbers Indicating Quantity

In an illustration, if a reference number indicates more than one part, the reference number has the form nX y. The n represents the quantity of the part, the X is the multiplication symbol, and the y represents the reference number.

For example, in an illustration, the reference number 2X 37 means that two of the parts identified by reference number 37 are indicated.

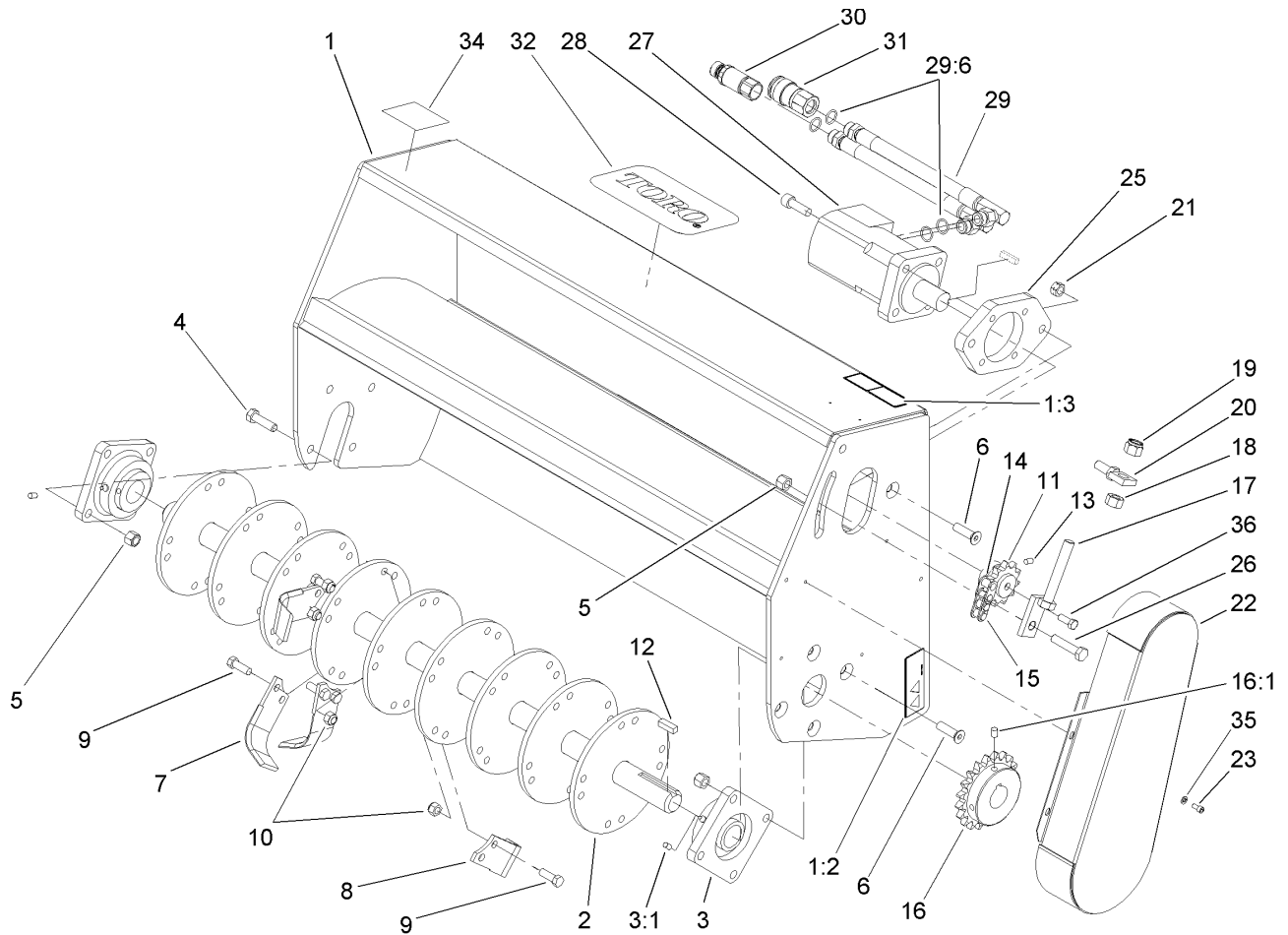

Tiller Assembly

Ref	Part No.	Qty.	Description
1	104-6263	1	Tiller Frame ASM
1:2	93-7321	2	Decal-Danger
1:3	107-9366	1	Decal-Warning
2	98-9087	1	Shaft-Tine
3	99-9979	2	Bearing ASM
3:1	3246-17	2	Setscrew-HSH
4	325-7	4	Screw-HH
5	3296-23	10	Nut-Lock, NI
6	98-9931	5	Bolt
7	104-2043	18	Tine-RH
8	104-2044	18	Tine-LH
9	324-29	72	Bolt-HH
10	32146-7	72	Nut-Lock, Insert
11	98-9085	1	Sprocket-11 Tooth
12	98-9935	1	Key-Square
13	3246-4	2	Screw-Set
14	98-9088	1	Chain-Roller
15	98-9089	1	Link-Connecting
16	98-9086	1	Sprocket-20 Tooth
16:1	3247-3	2	Screw-Set
17	98-9082	1	Chain Adjustment ASM
18	3217-11	1	Nut-Hex
19	3296-53	1	Nut-Lock, NI
20	99-5044	1	Holder-Adjustment

Ref	Part No.	Qty.	Description
21	104-6266	1	Nut-Side Deform
22	98-9071	1	Cover-Chain, Tiller
23	3274-52	4	Screw-HSH
25	98-9070	1	Plate-Mount, Motor
26	325-9	1	Screw-HH
27	98-9084	1	Motor-HYD
28	3274-4	4	Screw-HSH
29	104-6207	2	HYD Hose ASM
29:6	237-80	2	O-Ring
30	100-4701	1	Nipple-Connect, Pressure
30:1	100-6120	1	Seal Kit (Not Illustrated)
31	104-6134	1	Coupler-Face, Flush
31:1	105-8396	1	Seal Kit (Not Illustrated)
32	92-1242	1	Decal
34	98-3269	1	Decal
35	3253-3	4	Washer-Lock
36	323-6	1	Screw-HH

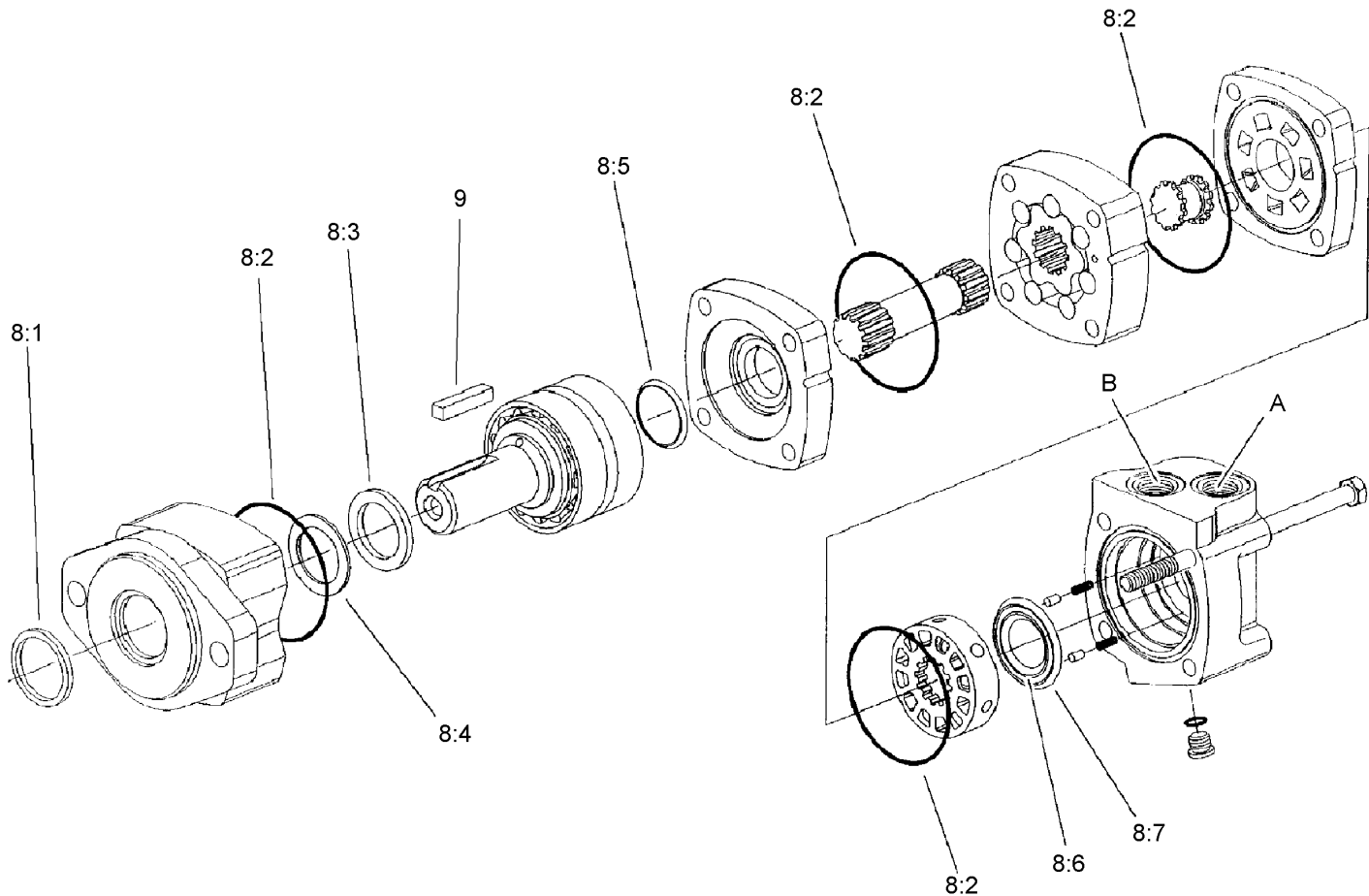

Hydraulic Motor Assembly No. 98-9084

Ref	Part No.	Qty.	Description
8	56-6890	1	Seal Kit
8:1		4	Seal-Dust (Not Serviced Separately)
8:2		1	Seal-Exclusion, Shaft (Not Serviced Separately)
8:3		1	Seal-Shaft (Not Serviced Separately)
8:4		1	Ring-Back-Up (Not Serviced Separately)
8:5		1	Seal-Face, Shaft (Not Serviced Separately)
8:6		1	Seal-Face, Inner (Not Serviced Separately)
8:7		1	Seal-Face, Outer (Not Serviced Separately)
9	98-9934	1	Key-Square

