



**Mid-Size ProLine
T-Bar, Gear Drive
13 HP with 32in Side Discharge Mower**

Model No. 30316 - 260000001 and up.

Parts Catalog

Ordering Replacement Parts

To order replacement parts, please supply the part number, the quantity, and the description of each part desired.

Understanding Reference Numbers

Each Identified part in an illustration has a reference number. The reference number for a part also appears in the parts list, along with other information about the part.

This catalog uses two special reference number formats, one to indicate parts in a service assembly and another to indicate the quantity of a given part in an illustration.

Service Assembly Reference Numbers

Parts in service assemblies have reference numbers in the form a:b. The a represents the reference number of the entire service assembly and the b represents a sequential number unique to each part within the service assembly.

For example, a wheel assembly might be identified by reference number 6, the tire by 6:1, the valve by 6:2, and the wheel by 6:3. When you order the assembly identified by reference number 6, you receive all parts identified by reference numbers 6:1, 6:2, and 6:3. However, you may also order any part individually. Reference numbers of this type appear in illustrations and in part lists.

Reference Numbers Indicating Quantity

In an illustration, if a reference number indicates more than one part, the reference number has the form nX y. The n represents the quantity of the part, the X is the multiplication symbol, and the y represents the reference number.

For example, in an illustration, the reference number 2X 37 means that two of the parts identified by reference number 37 are indicated.

Contents

Description	Page	Description	Page
Fuel Tank and Idler Bracket Assembly 3	Head, Valve and Breather Assembly Kohler CV13T 21540 15
Transmission and Idler Pulley Assembly 4	Ignition and Electrical Assembly Kohler CV13T 21540 16
Brake, Wheel Pulley and Wheel Assembly 5	Blower Housing and Baffle Assembly Kohler CV13T 21540 17
Handle and Control Panel Assembly 6	Starting System Assembly Kohler CV13T 21540 18
Engine Assembly 7	Fuel System Assembly Kohler CV13T 21540 19
Carrier Assembly 8	Engine Control Assembly Kohler CV13T 21540 20
Deck Assembly 9	Air Intake and Filtration Assembly Kohler CV13T 21540 21
Spindle and Blade Assembly 10	Exhaust Assembly Kohler CV13T 21540 22
Decal and Mulcher Cover Assembly 11		
Crankshaft Assembly Kohler CV13T 21540 12		
Crankcase Assembly Kohler CV13T 21540 13		
Oil Pan and Lubrication Assembly Kohler CV13T 21540 14		

Part Description Abbreviations

Part descriptions in this catalog may include the following abbreviations.

AR. as required	INC. incorporated
ASM. assembly	LH. left hand
BBC. blade brake clutch	NI. nylon insert
CARR. carriage	NPTF. national pipe thread fine
DEG. degrees	PFH. phillips flat head
EXT. external	PPH. phillips pan head
FH. flat head	PPHTF. phillips pan head thread forming
GA. gauge	PRH. phillips round head
HF. hex flange	PTH. phillips truss head
HH. hex head	PTO. power-take-off
HHF. hex head flange	RH. right hand
HHFTF. hex head flange thread forming	ROPS. roll-over-protection-system
HJ. hex jam	SFH. slotted fillister head
HLH. hex lag head	SHH. slotted hex head
HOC. height-of-cut	SHWH. slotted hex washer head
HSBH. hex socket button head	SPH. slotted pan head
HSFH. hex socket flat head	SQH. square head
HSH. hex socket head	SRH. slotted round head
HWH. hex washer head	STD. standard
HWHTF. hex washer head thread forming	TAP. self tapping
HYD. hydraulic	TTH. torx truss head

Footnotes

- ❶ Not illustrated
- ❷ Obtain from your local Kohler dealer
- ❸ Not serviced separately

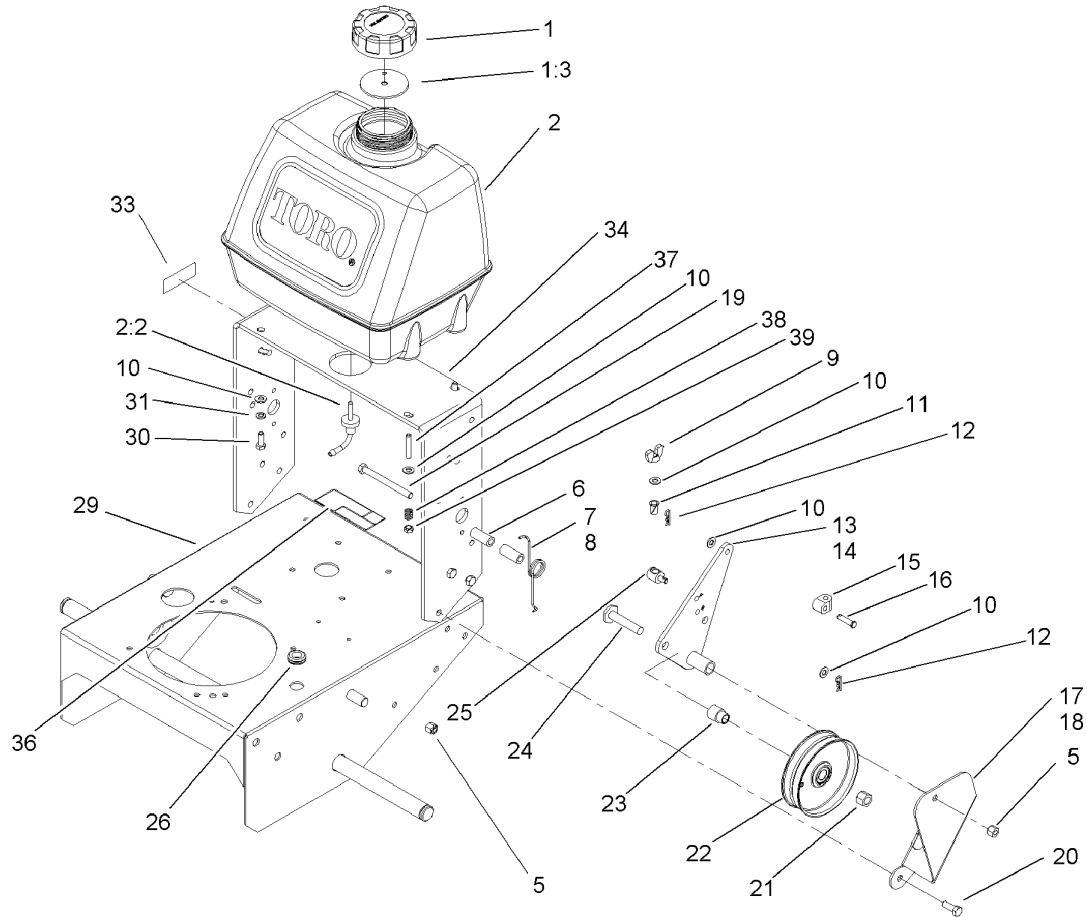

Fuel Tank and Idler Bracket Assembly

Ref	Part No.	Qty.	Description
1	88-3980	1	Gas Cap ASM
1:3	88-4010	1	Gasket-Cap, Gas
2	106-0730	1	Fuel Tank ASM
2:2	103-2605	1	Fitting-Fuel, Bulkhead
5	3296-39	8	Nut-Lock, NI
6	74-0040	4	Spacer-Pivot, Idler
7	51-4370	1	Spring-Torsion, RH
8	51-4380	1	Spring-Torsion, LH
9	32103-25	2	Nut-Wing
10	3256-23	10	Washer-Flat
11	52-2890	2	Bushing-Nylon
12	3290-307	4	Pin-Hair
13	74-0230-01	1	Bracket-Idler, RH
14	74-0220-01	1	Bracket-Idler, LH
15	74-0521	2	Fitting-Rod
16	283-6	2	Pin-Clevis
17	67-6370-01	1	Bracket-Support, RH
18	67-6380-01	1	Bracket-Support, LH
19	323-16	2	Screw-HH
20	323-6	6	Screw-HH
21	3296-23	2	Nut-Lock, NI
22	95-2800	2	Pulley-Idler
23	95-2801	2	Spacer-Pulley
24	51-4450	2	Screw-Leveler

Ref	Part No.	Qty.	Description
25	68-9690	2	Fitting-Rod
26	237-124	1	Grommet
29	105-4670-01	1	Frame ASM
30	322-4	4	Screw-HH
31	3253-4	2	Washer-Lock
33	95-2814	1	Decal-Shut Off, Fuel
34	106-0649-01	1	Frame-Upper
36	98-0776	1	Decal-Caution
37	104-8121	2	Stud-Threaded
38	1-633349	2	Spring-Tank, Fuel
39	3296-47	2	Nut-Lock, NI

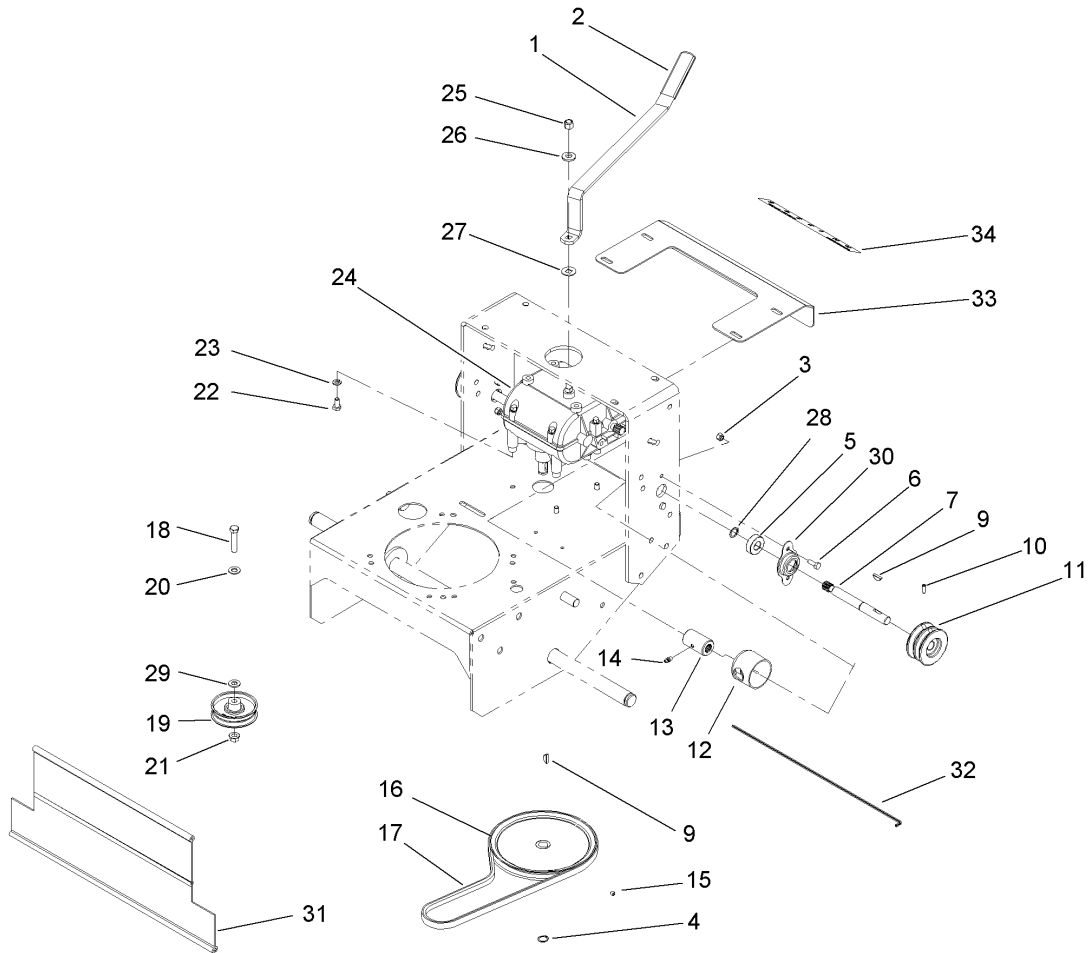

Transmission and Idler Pulley Assembly

Ref	Part No.	Qty.	Description
1	98-3274-03	1	Lever-Shift
2	47-1970	1	Grip
3	3296-42	4	Nut-Lock, NI
4	32120-64	1	Ring-Snap, External
5	1-323252	2	Bearing-Shaft
6	321-4	4	Screw-HH
7	104-1102	2	Shaft-Output
9	3257-5	3	Key-Woodruff
10	3245-3	2	Screw-Set, Hs
11	105-2698	2	Pulley-Transmission
12	51-4220	2	Guard-Coupler
13	1-323680	2	Coupler
14	302-5	2	Fitting-Grease
15	3245-1	1	Screw-Set, HSH
16	51-4190	1	Pulley-Driven
17	26-9671	1	V-Belt
18	323-9	1	Screw-HH
19	51-4810	1	Pulley-Idler
20	3256-24	1	Washer-Flat
21	32128-21	1	Nut-HF
22	322-2	4	Screw-HH
23	3253-4	4	Washer-Lock
24	1-323500	1	Transmission
25	3296-6	1	Nut-Lock

Ref	Part No.	Qty.	Description
26	98-5975	1	Washer-Belleville
27	1-323379	1	Washer
28	32151-62	2	Ring-Retaining
29	3256-24	1	Washer-Flat
30	1-323254	2	Flange-Output
31	95-1526	1	Shield-Trailing
32	95-1529	1	Rod-Shield
33	104-8102-01	1	Plate-Gate, Shift
34	98-3256	1	Decal-Speed, Ground

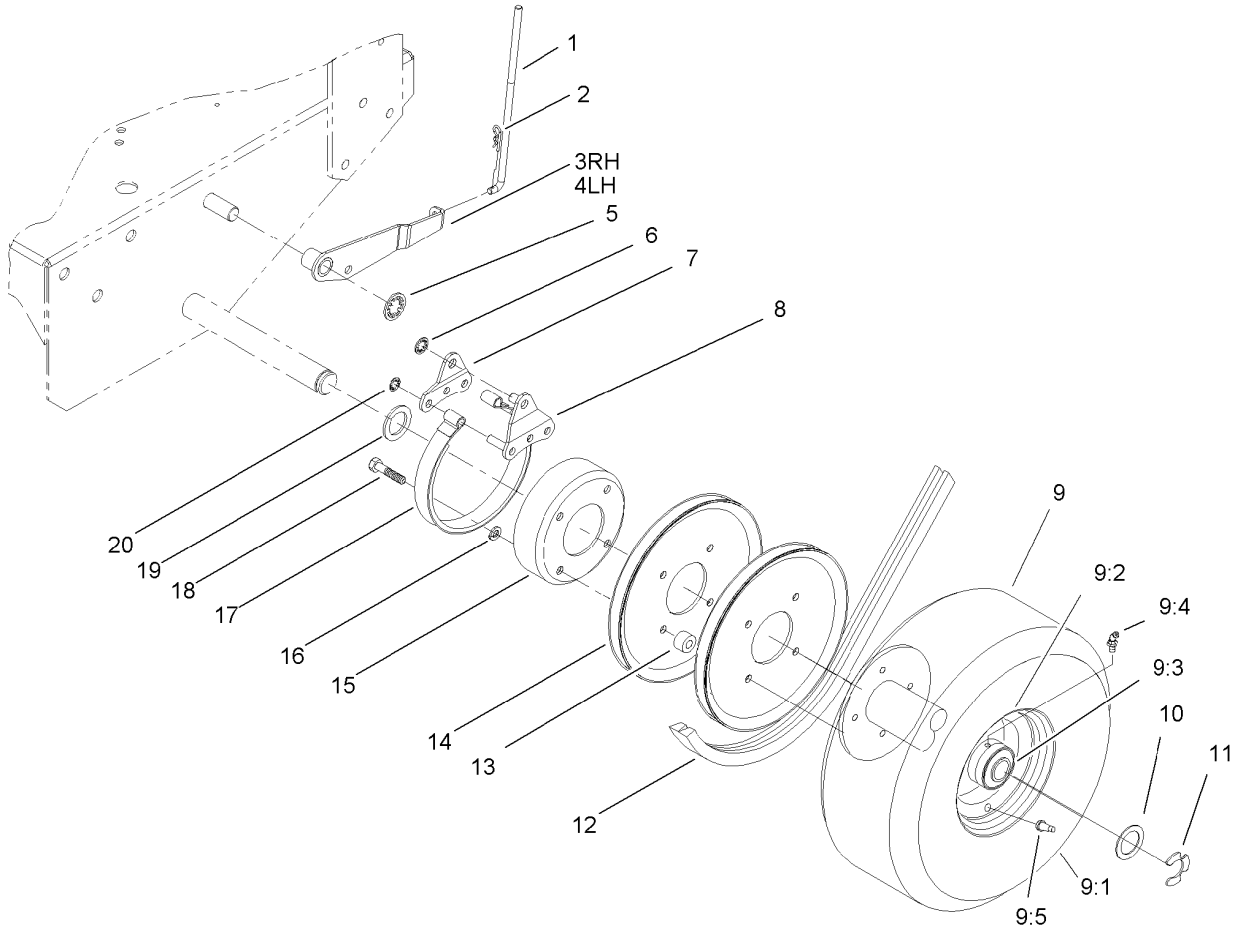

Brake, Wheel Pulley and Wheel Assembly

Ref	Part No.	Qty.	Description
1	51-4580	2	Rod-Brake
2	3290-307	2	Pin-Hair
3	67-6400-01	1	Arm-Brake, RH
4	67-6420-01	1	Arm-Brake, LH
5	32151-40	2	Ring-Retaining
6	32151-56	2	Ring-Retaining, External
7	51-4660-01	2	Plate-Link, Brake
8	51-4650-01	2	Link-Brake
9	93-1163	2	Wheel And Tire ASM
9:1	231-94	1	Tire-Front
9:2	93-1181	1	Wheel ASM
9:3	92-1746	2	Bearing-Ball
9:4	302-57	1	Fitting-Grease
9:5	232-27	1	Stem-Valve
10	10-8110	8	Washer-Thrust
11	32151-91	2	Ring-Retaining
12	51-4291	2	V-Belt
13	51-4170	8	Spacer-Pulley
14	51-4160-03	4	Pulley-Wheel
15	51-4180-03	2	Drum-Brake
16	3253-4	8	Washer-Lock
17	51-4700	2	Band-Brake
18	322-7	8	Screw-HH
19	51-4230	2	Washer-Wheel

Ref	Part No.	Qty.	Description
20	32151-72	4	Ring-Retaining

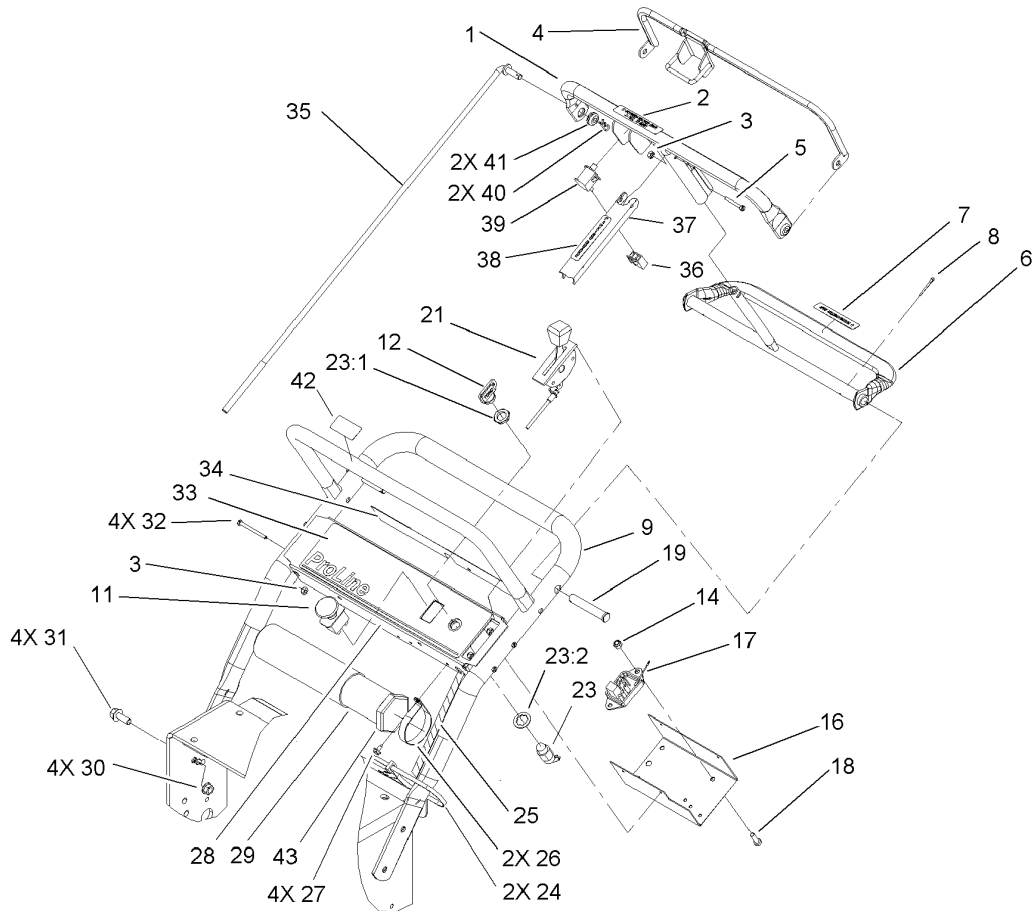

Handle and Control Panel Assembly

Ref	Part No.	Qty.	Description
1	82-7690-03	1	Bar-Control
2	82-2290	1	Decal
3	3296-2	5	Nut-Lock
4	82-7680-03	1	Bail ASM
5	32105-1	1	Screw-SHH
6	106-5477-03	1	Control Pivot ASM
7	82-2280	1	Decal
8	3272-11	2	Pin-Cotter
9	105-3158-03	1	Upper Handle ASM
11	104-8140	1	Switch-PTO
12	63-8360	2	Key-Ignition
14	3296-42	1	Nut-Lock, NI
16	93-1187-03	1	Panel-Bottom
17	104-8141	1	Module-Delay
18	321-2	1	Screw-HH
19	283-55	2	Pin-Clevis
21	74-0630	1	Control-Throttle
23	29-5560	1	Switch-On / Off
23:1	218-461	1	Nut-HH
23:2	3254-5	1	Washer-Tooth
24	3290-378	2	Tie-Cable
25	104-8136	1	Harness-Wire
26	2412-120	2	R-Clamp
27	32104-76	4	Screw

Ref	Part No.	Qty.	Description
28	104-8177-03	1	Panel-Control
29	104-7050	1	Housing-Manual
30	32128-21	4	Nut-HF
31	3234-11	4	Screw-HHF
32	32105-14	4	Screw-SHH
33	106-5499	1	Decal-Control Panel
34	105-0884	1	Decal-Danger
35	82-7632	2	Rod-Control
36	218-595	1	Connector-Body
37	51-4850-03	1	Lever-Brake, Parking
38	52-2010	1	Decal-Lever, Parking
39	82-2190	1	Switch-Bail
40	3290-307	2	Pin-Hair
41	237-141	2	Grommet-Rubber
42	98-4387	1	Decal-Protection, Ear
43	104-7048	1	Cap-Housing

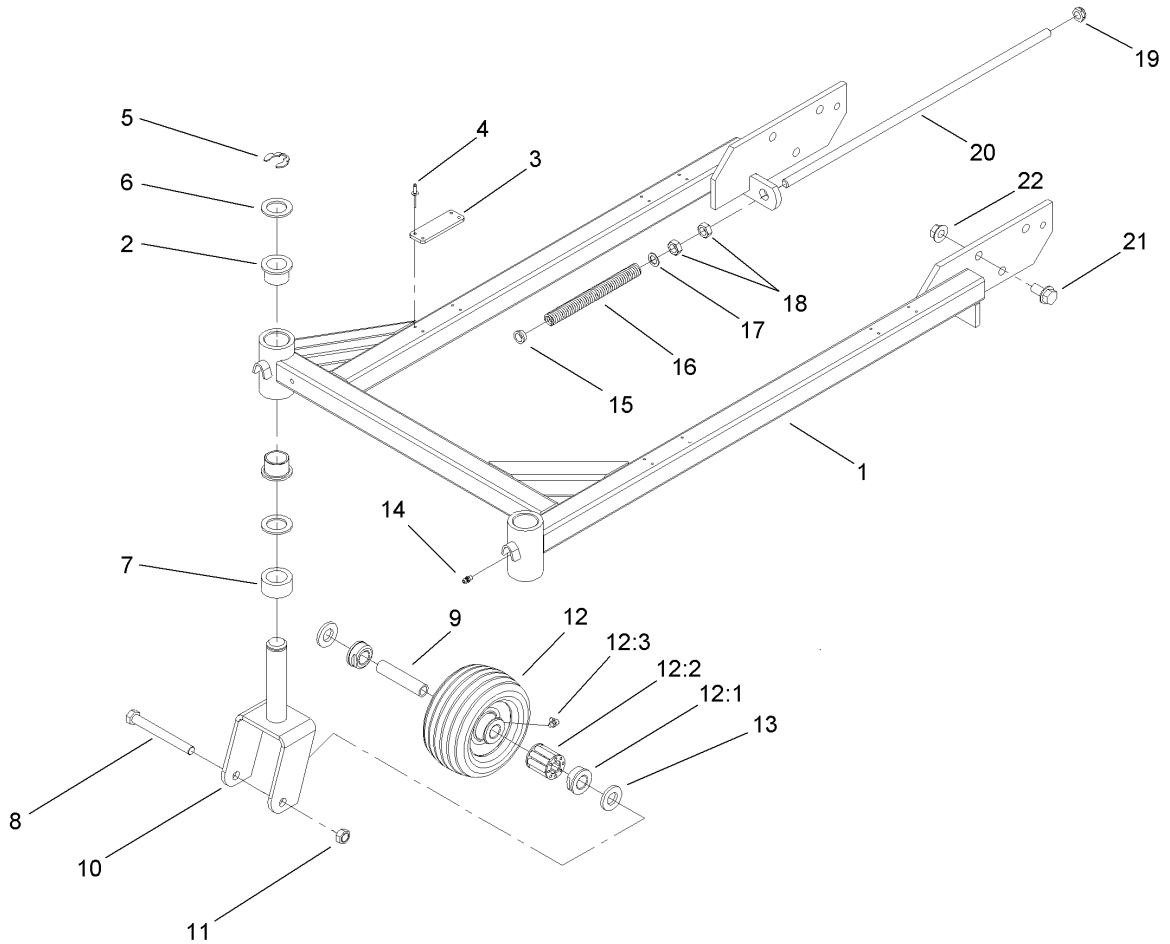

Carrier Assembly

Ref	Part No.	Qty.	Description
1	74-0080	1	Carrier Frame ASM
2	94-1291	4	Bushing
3	74-0330	4	Pad-Rubber
4	3269-24	16	Rivet
5	32151-91	2	Ring-Retaining
6	3-6781	4	Washer-Thrust
7	93-1166	2	Spacer-Castor
8	325-18	2	Screw-HH
9	67-6220	2	Spanner
10	93-1164-01	2	Fork-Caster ASM
11	32153-5	2	Nut-Lock, Side
12	63-8400	2	Caster Wheel ASM
12:1	62-5580	2	Bearing-Outside
12:2	63-8580	1	Bearing-Roller
12:3	302-40	1	Fitting-Grease
13	67-6570	4	Spacer-Wheel
14	302-5	2	Fitting-Grease
15	256-156	2	Bushing-Flange
16	74-0290	2	Spring
17	41-8440	2	Washer
18	3218-5	4	Nut-Jam
19	74-0310	2	Shaft-Adjusting
20	3296-45	2	Nut-Lock, NI
21	3234-6	6	Screw-HHF

Ref	Part No.	Qty.	Description
22	32128-23	6	Nut-HF

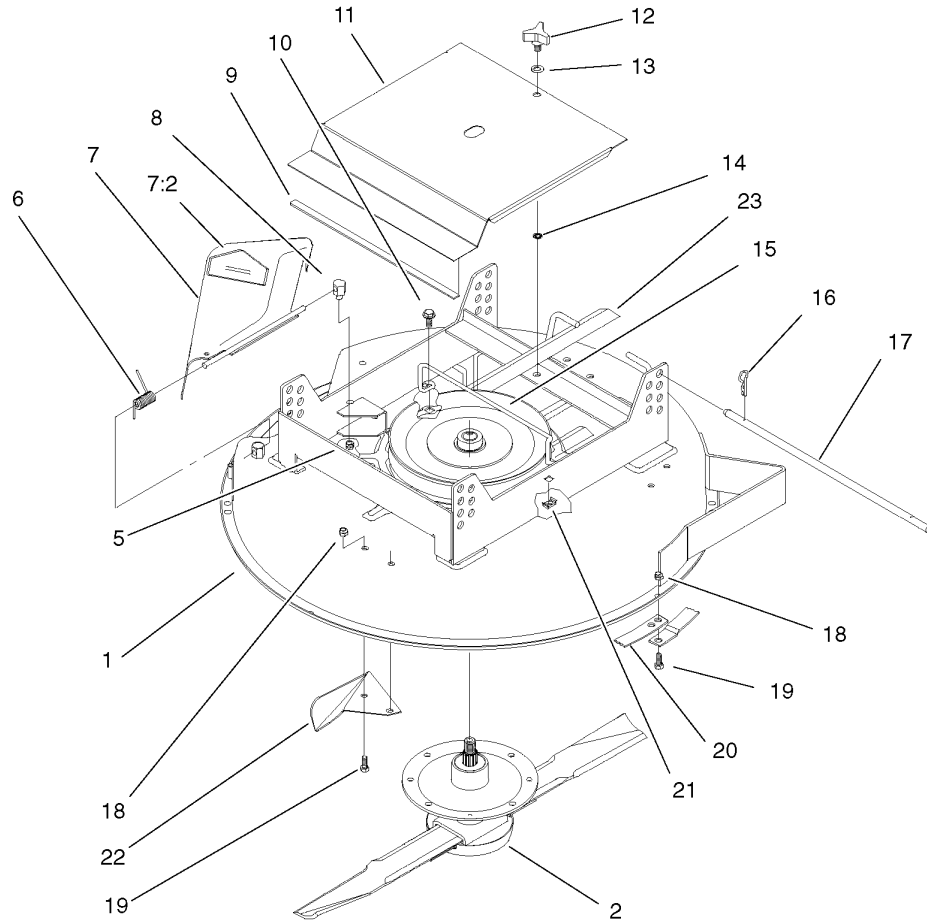

Deck Assembly

Ref	Part No.	Qty.	Description				
①		1	Deck ASM				
②		1	Spindle ASM				
5	32153-2	1	Nut-Lock, Side				
6	28-8010	1	Spring				
7	44-5930	1	Deflector ASM				
7:2	54-9220	1	Decal-Danger				
8	28-7350	1	Post-Pivot				
9	67-6180	1	Strip-Magnetic				
10	3234-29	2	Screw-HHF				
11	67-6160-01	1	Cover				
12	104-8587	1	Knob				
13	3256-24	1	Washer-Flat				
14	32151-72	1	Ring-Retaining				
15	74-0570	1	Guide-Belt				
16	3290-355	4	Pin-Hair				
17	67-6140	2	Rod-Support				
18	3296-29	24	Nut-Lock, NI				
19	322-4	24	Screw-HH				
20	92-5419-03	4	Ring-Recycler				
21	3290-496	2	Nut-Retainer				
22	80-2630-03	4	Kicker				
23	67-6920	1	V-Belt				

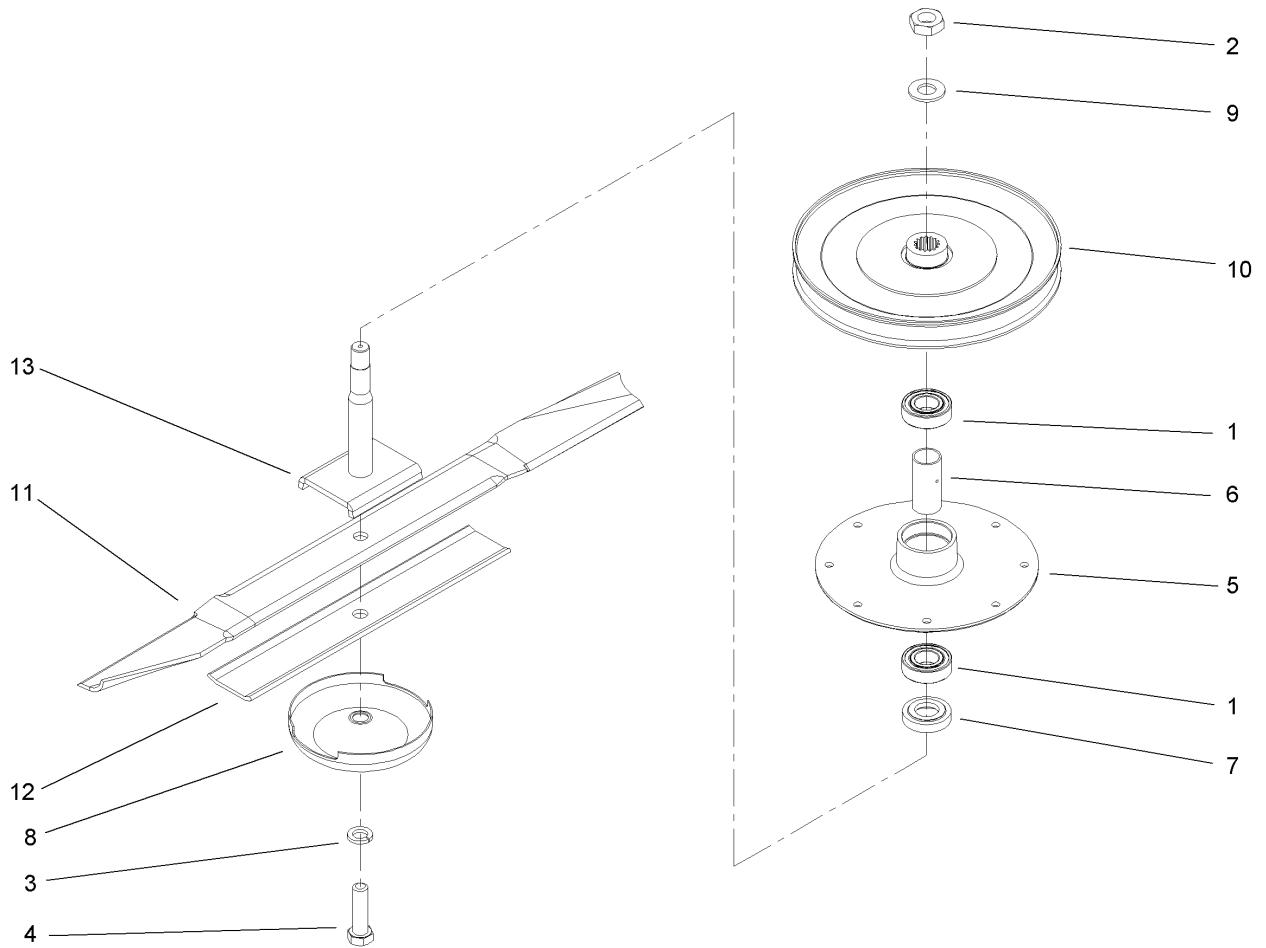

Spindle and Blade Assembly

Ref	Part No.	Qty.	Description
1	104-6325	2	Bearing
2	32146-20	1	Nut-Jam
3	3253-23	1	Washer-Lock/Sp
4	51-4060	1	Screw-Blade
5	67-6060	1	Housing-Spindle
6	67-6070	1	Spacer-Bearing
7	67-6080	1	Spacer
8	92-6313	1	Cup-Anti Scalp
9	106-0776	1	Washer-Pinion
10	74-0580	1	Pulley ASM
11	80-4430-03	1	Blade-Recycler
12	82-4750-03	1	Blade Spacer
13	105-4607-03	1	Spindle Shaft ASM

--	--	--	--

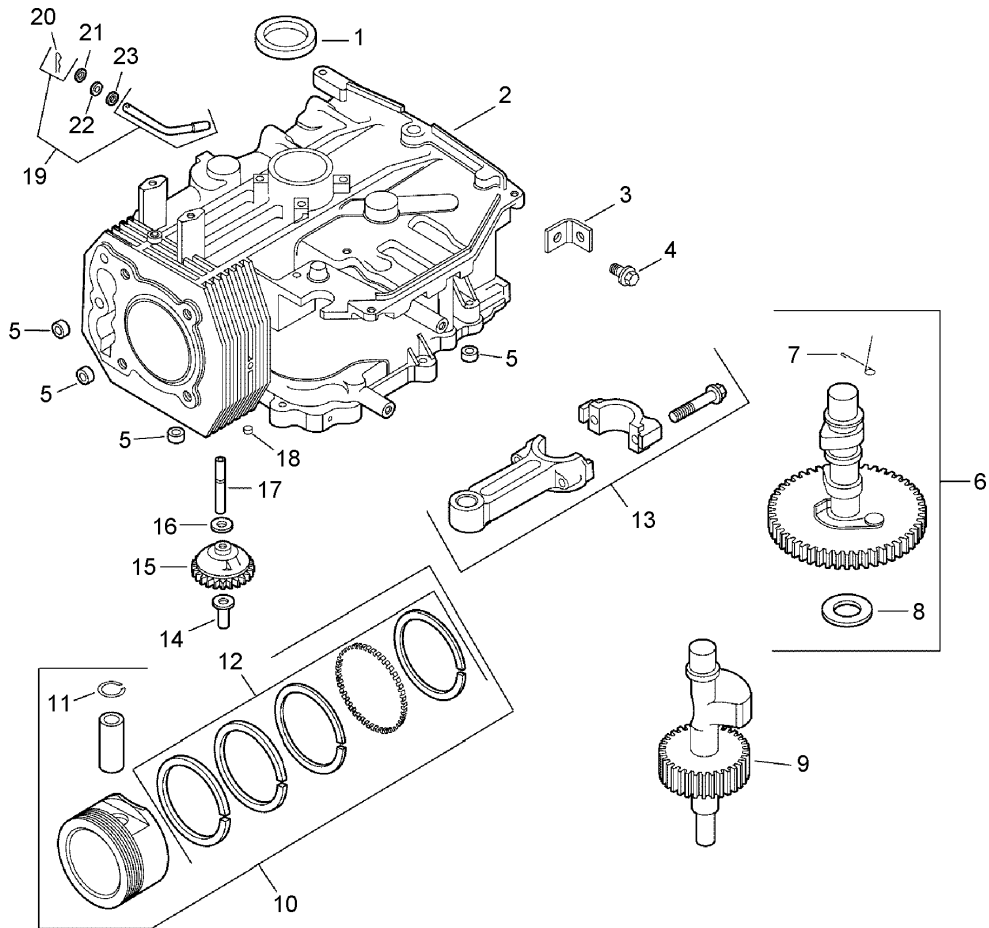

Crankcase Assembly Kohler CV13T 21540

Ref	Part No.	Qty.	Description
●1	12 032 03-S	1	Seal-Oil
●●2		1	Crankcase (Use: Short Block 12 522 33)
●3	12 445 02-S	1	Strap-Lifting
●4	M-839025-S	1	Screw-HF (M8X1.25X25)
●5	24 380 13-S	4	Pin-Locating
●6	12 755 49-S	1	Camshaft Kit (Incl. Ref. #7 And 8)
●7	12 089 37-S	1	Spring-Actuating
●8	12 422 08-S	1	Shim-Camshaft, Blue
●8	12 422 09-S	1	Shim-Camshaft, Red
●8	12 422 10-S	1	Shim-Camshaft, Yellow
●8	12 422 11-S	1	Shim-Camshaft, Green
●8	12 422 12-S	1	Shim-Camshaft, Gray
●8	12 422 13-S	1	Shim-Camshaft, Black
●8	12 422 07-S	1	Shim-Camshaft, White
●9	12 144 27-S	1	Shaft-Balance
●10	12 874 01-S	1	Piston W/Ring Set (STD) (Incl. Ref. #11 And 12)
●10	12 874 10-S	1	Piston W/Ring Set (.08)
●10	12 874 02-S	1	Piston W/Ring Set (.25)
●10	12 874 03-S	1	Piston W/Ring Set (.50)
●11	12 018 02-S	2	Retainer-Pin, Piston
●12	12 108 01-S	1	Ring Set (STD And .08)
●12	12 108 02-S	1	Ring Set (.25)

Ref	Part No.	Qty.	Description
●12	12 108 03-S	1	Ring Set (.50)
●13	12 067 05-S	1	Rod-Connecting (STD)
●13	12 067 06-S	1	Rod-Connecting (.25)
●14	12 380 01-S	1	Pin-Regulating, Governor
●15	12 043 05-S	1	Gear-Governor
●16	M-631005-S	1	Washer-Plain (6Mm)
●17	12 144 02-S	1	Shaft-Gear, Governor
●18	52 139 09-S	1	Plug-Cup
●19	12 755 64-S	1	Governor Cross Shaft Kit (Includes 20)
●20	12 154 05-S	1	Clip-Pin, Hitch
●21	X-25-102-S	1	Washer-Plain (1/4In)
●22	12 032 01-S	1	Seal-Cross Shaft, Governor
●23	M-631015-S	1	Washer-Plain (6Mm)

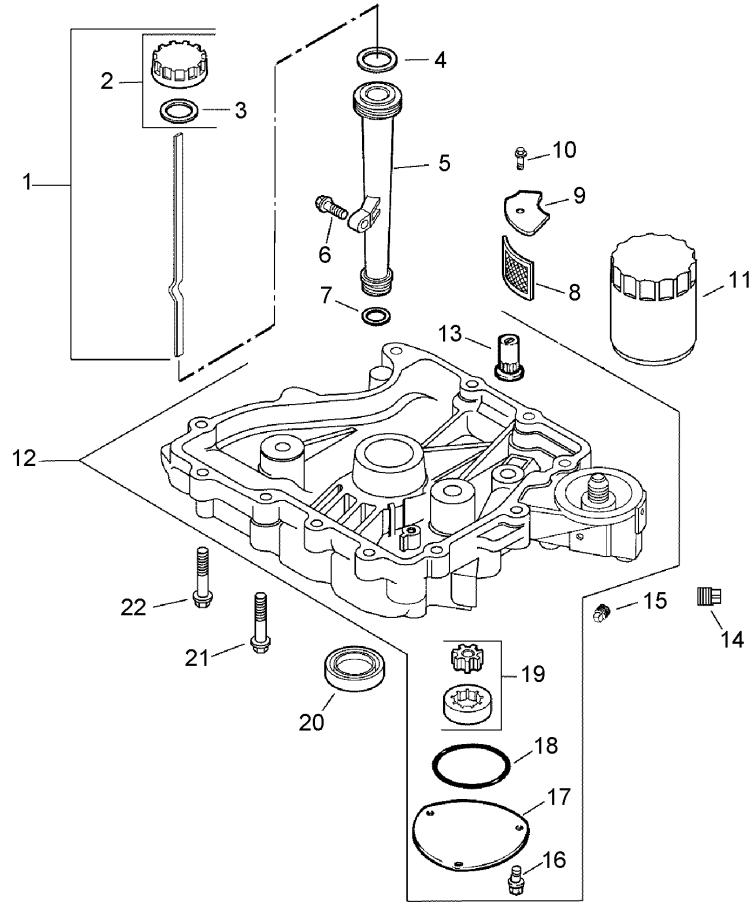

Oil Pan and Lubrication Assembly Kohler CV13T 21540

Ref	Part No.	Qty.	Description
1	12 038 01-S	1	Dipstick ASM (Incl. Ref. #2 And 3)
2	25 755 13-S	1	Oil Fill Cap ASM (Incl. Ref. #3)
3	25 153 02-S	1	O-Ring (Dipstick)
4	12 153 02-S	1	O-Ring (Upper Oil Fill Tube)
5	12 123 04-S	1	Tube-Fill, Oil
6	M-545020-S	1	Screw-HF (M5X0.8X20)
7	12 153 01-S	1	O-Ring (Lower Oil Fill Tube)
8	25 162 07-S	1	Screen-Pickup, Oil
9	12 096 03-S	1	Cover-Screen, Oil Pickup
10	M-545016-S	1	Screw-HF (M5X0.8X16)
11	12 050 01-S	1	Filter-Oil
12	12 199 50-S	1	Oil Pan ASM (Incl. Ref. #13, 16-19)
13	25 462 09-S	1	Valve-Relief, Oil Pressure
14	25 139 57-S	2	Plug-SQH (3/8In NPTF)
15	25 139 52-S	1	Plug-Pipe (1/8In)
16	M-545016-S	3	Screw-HF (M5X0.8X16)
17	12 096 34-S	1	Cover-Pump, Oil
18	12 153 06-S	1	O-Ring (Oil Pump Cover)
19	12 393 01-S	1	Oil Pump ASM
20	12 032 03-S	1	Seal-Oil (PTO End)
21	24 086 16-S	10	Screw-HF (M8X1.25X45)
22	24 086 17-S	1	Screw-HF (M8X1.25X45)

--	--	--	--

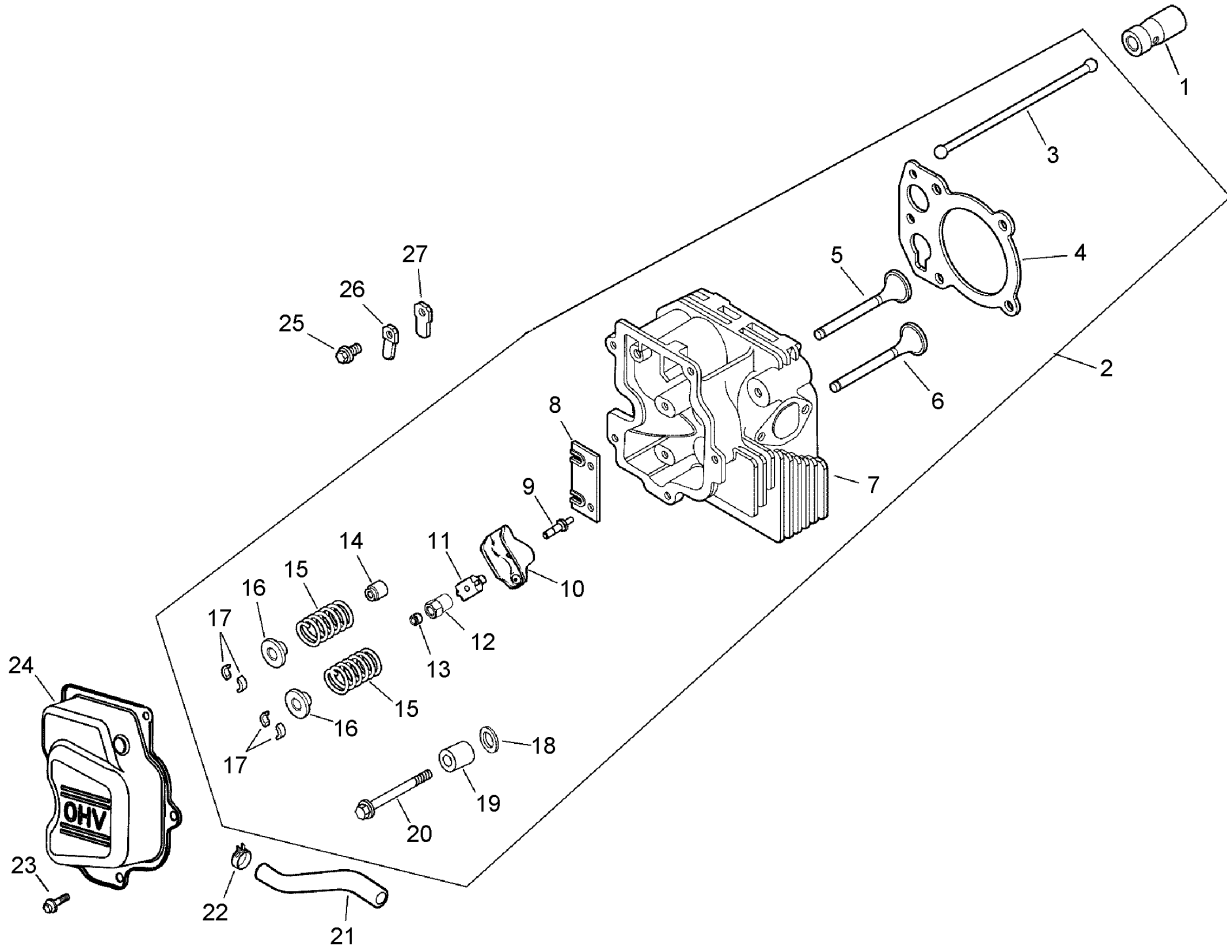

Head, Valve and Breather Assembly Kohler CV13T 21540

Ref	Part No.	Qty.	Description
❶	25 351 01-S	2	Lifter-Valve
❷	12 755 81-S	1	Cylinder Head Kit (Incl. Ref. #3-18, Carburetor Gasket 12 041 01-S (2), Air Cleaner Base Gasket 12 041 02-S, Exhaust Manifold Gasket 12 041 03-S)
❸	12 411 04-S	2	Rod-Push
❹	12 041 08-S	1	Gasket-Head, Cylinder
❺	12 017 01-S	1	Valve-Intake (STD)
❻	12 016 01-S	1	Valve-Exhaust (STD)
❼	12 318 19-S	1	Head-Cylinder
❽	12 146 22-S	2	Plate-Guide
❾	25 072 12-S	2	Stud-Rocker
❿	25 186 01-S	2	Arm-Rocker
⓫	24 599 01-S	2	Pivot-Arm, Rocker
⓬	25 100 29-S	2	Nut-Hex
⓭	25 086 112-S	2	Screw-Set
⓮	66 032 05-S	2	Seal-Stem, Valve
⓯	12 089 34-S	2	Spring-Valve
⓰	12 173 01-S	2	Cap-Spring, Valve
⓱	12 755 03-S	2	Retainer Kit
⓲	12 468 05-S	1	Washer-Plain (13/32In)
⓳	12 112 13-S	1	Spacer-Head Bolt (Exhaust Port)
⓴	20 086 02-S	5	Screw-HF (M10X1.5X81)
⓵	12 326 18-S	1	Hose-Breather

Ref	Part No.	Qty.	Description
❷❷	25 237 14-S	1	Clamp
❷❸	M-645016-S	3	Screw-HF (M6X1.0X16)
❷❹	12 096 47-S	1	Cover-Valve
❷❺	M-545010-S	1	Screw-HF (M5X0.8X10)
❷❻	66 018 04-S	1	Retainer-Reed, Breather
❷❼	12 402 02-S	1	Reed-Breather
❶❶	12 017 02-S	1	Valve-Intake (.25)
❶❷	12 016 02-S	1	Valve-Exhaust (.25)
❶❸	12 041 01-S	1	Gasket-Carburetor
❶❹	12 041 02-S	1	Gasket-Cleaner, Air
❶❺	12 041 03-S	1	Gasket-Manifold, Exhaust

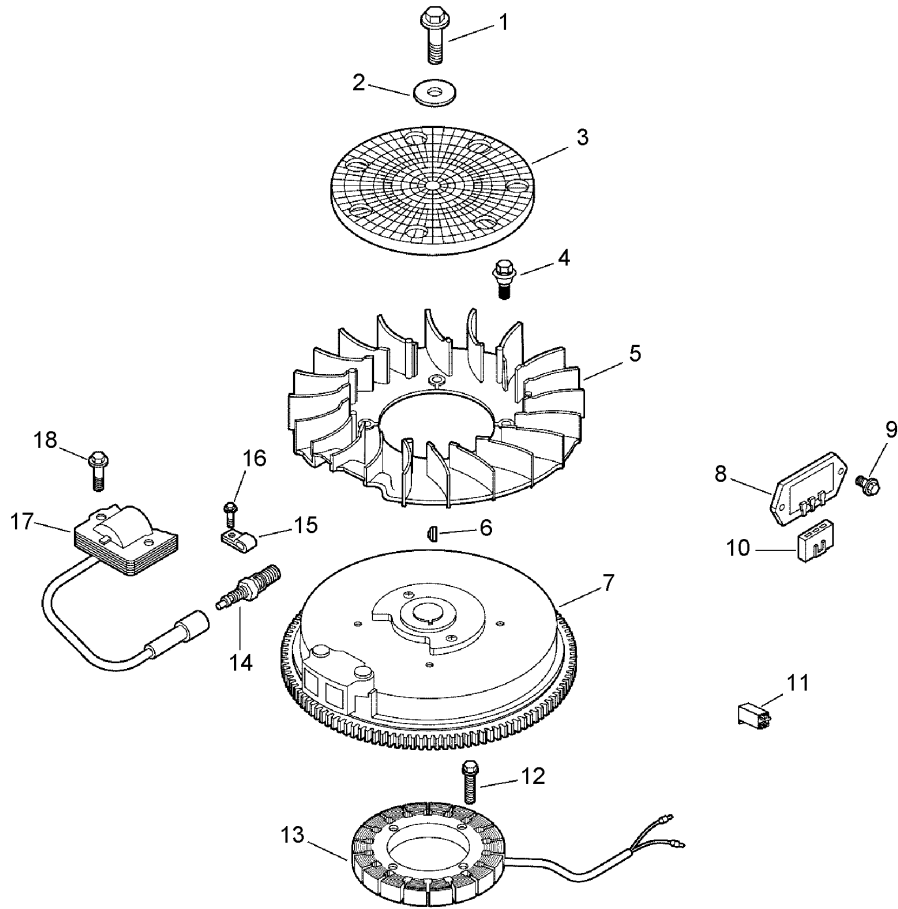

Ignition and Electrical Assembly Kohler CV13T 21540

Ref	Part No.	Qty.	Description
1	12 086 14-S	1	Screw-HF (M10X1.5X46)
2	12 468 03-S	1	Washer-Plain (3/8In)
3	24 162 03-S	1	Screen-Grass
4	25 086 47-S	4	Bolt-Shoulder (M6X1.0X16)
5	12 157 03-S	1	Fan
6	X-42-15-S	1	Key
7	12 025 53-S	1	Flywheel
8	12 403 01-S	1	Rectifier-Regulator
9	M-639016-S	2	Screw-HF (M6X1.0X16)
10	236602-S	1	Connector
11	41 155 03-S	1	Connector
12	M-548025-S	2	Screw (M5X0.8X25)
13	237878-S	1	Stator Kit (Includes 25 452 01-S)
14	12 132 02-S	1	Spark Plug
15	X-728-1-S	2	Clip
16	M-545010-S	2	Screw-HF (M5X0.8X10)
17	12 584 05-S	1	Module-Ignition
18	M-545020-S	2	Screw-HF (M5X0.8X20)
19	X-25-5-S	1	Washer-Steel
20	12 126 96-S	1	Bracket-Strap, Ground
21	12 518 01-S	1	Lead-White (19In - 18 Gauge- Fully Insulated Female Terminal And Uninsulated Female Terminal)

Ref	Part No.	Qty.	Description
22	25 518 05-S	1	Lead-Red (20In - 18 Gauge- Uninsulated Female Terminals)
23	25 452 01-S	2	Terminal

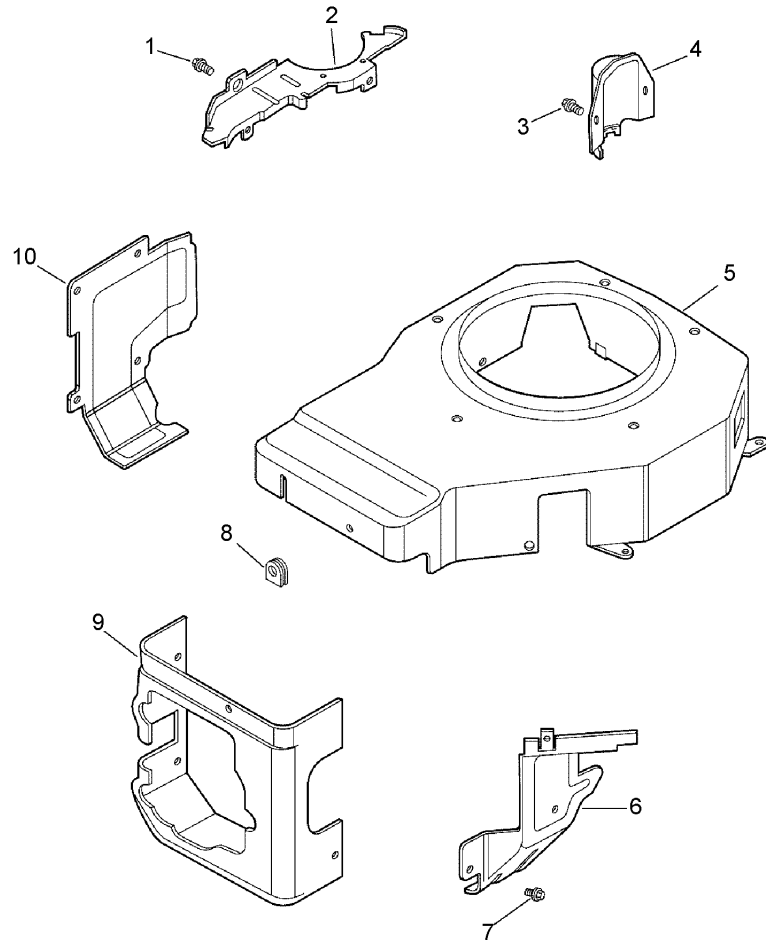

Blower Housing and Baffle Assembly Kohler CV13T 21540

Ref	Part No.	Qty.	Description
1	M-545010-S	8	Screw-HF (M5X0.8X10)
2	12 146 07-S	1	Plate-Housing, Blower
3	M-550010-S	6	Screw-HF (M5X0.8X10)
4	12 096 29-S	1	Cover-Starter
5	12 027 68-S	1	Housing-Blower
6	12 063 10-S	1	Baffle-Side, Intake
7	M-561016-S	1	Screw
8	12 313 03-S	1	Grommet-Spark Plug
9	12 063 08-S	1	Baffle-Head, Cylinder
10	12 063 19-S	1	Baffle-Cylinder
11	12 113 124-S	1	Decal-15Hp
12	25 113 39-S	1	Decal-Lamination, Clear

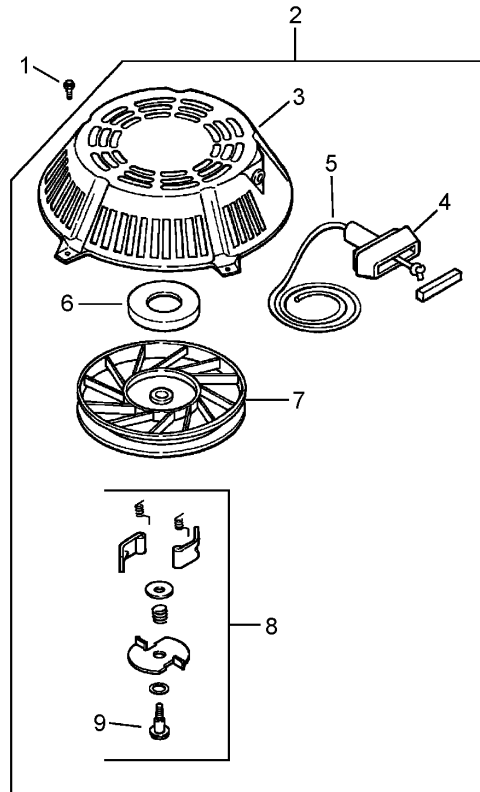

Starting System Assembly Kohler CV13T 21540

Ref	Part No.	Qty.	Description				
①	M-550010-S	5	Screw-HF (M5X0.8X10)				
②	12 165 01-S	1	Retractable Starter ASM (Incl. Ref. #3 And 9)				
③	12 081 01-S	1	Housing-Starter				
④	25 166 01-S	1	Handle-Start, Recoil				
⑤	12 160 01-S	1	Rope-Starter				
⑥	12 089 06-S	1	Spring And Keeper				
⑦	12 093 01-S	1	Pulley				
⑧	12 757 06-S	1	Dog Repair Kit				
⑨	41 086 09-S	1	Screw-Pozi Driv				
⑩	15 109 01-S	1	Cup-Drive				
⑩	12 113 07-S	1	Decal-Starting				

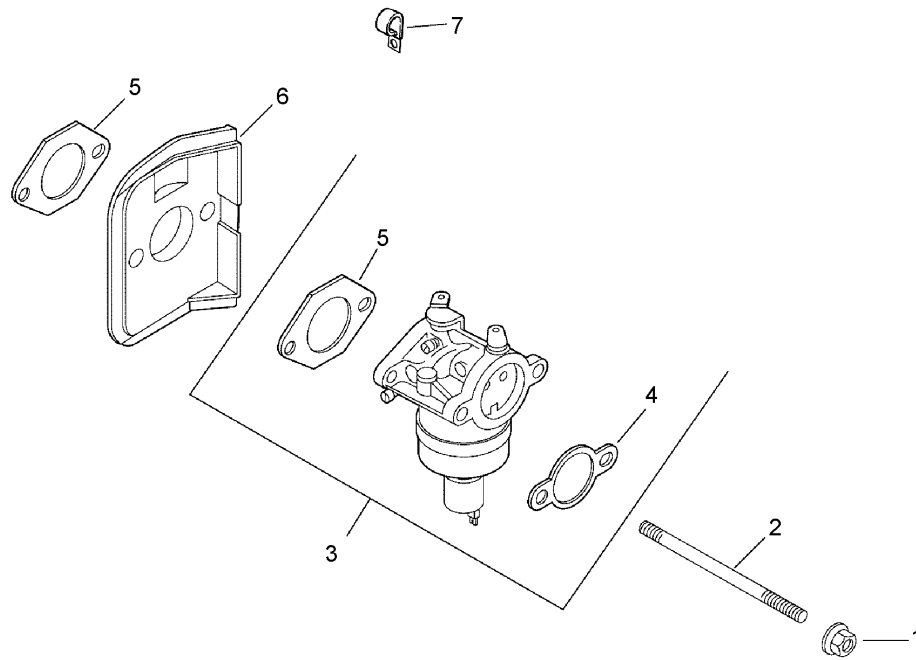

Fuel System Assembly Kohler CV13T 21540

Ref	Part No.	Qty.	Description				
①	M-641060-S	2	Nut-HF				
②	M-629116-S	2	Stud (M6X1.0X116)				
③	12 853 140-S	1	Carburetor Kit (Incl. Ref. #4, 5 [qty 1])				
④	12 041 02-S	1	Gasket-Cleaner, Air				
⑤	12 041 01-S	2	Gasket-Carburetor				
⑥	12 265 04-S	1	Deflector-Heat				
⑦	47 154 01-S	1	Clip-Cable				
①③	12 757 02-S	1	Float Kit				
①③	12 757 03-S	1	Carburetor Repair Kit				
①③	12 757 08-S	1	Choke Repair Kit				
①③	12 757 36-S	1	Throttle Shaft Bearing Kit				
①③	12 757 37-S	1	Bowl Replacement Kit				
①③	12 755 92-S	1	High Altitude Kit				

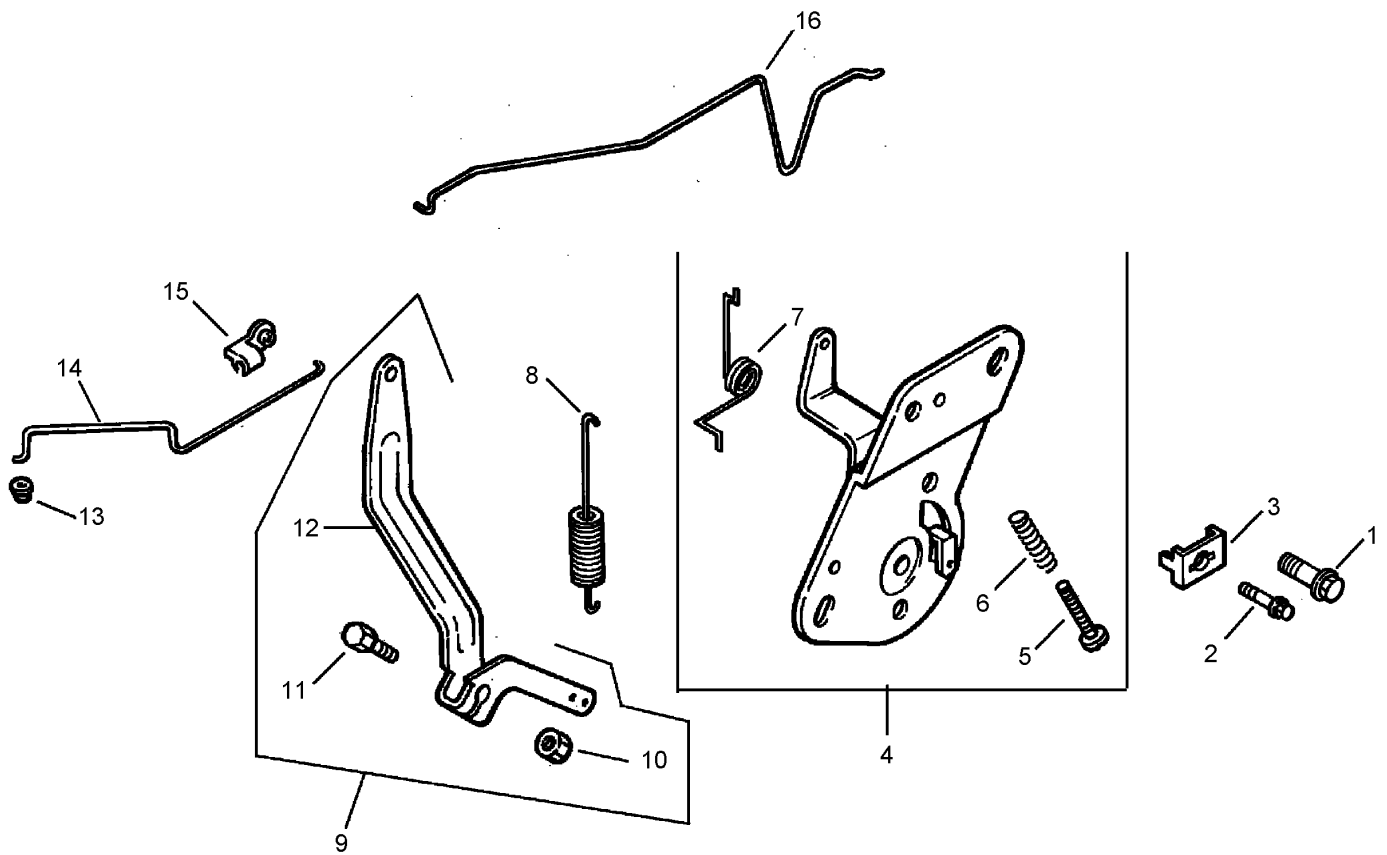

Engine Control Assembly Kohler CV13T 21540

Ref	Part No.	Qty.	Description
❶	M-664020-S	2	Screw-Socket, Lobed (M6X1.0X20)
❷	M-545016-S	1	Screw-HF (M5X0.8X16)
❸	12 237 01-S	1	Clamp-Cable
❹	12 536 01-S	1	Speed Control ASM (Incl. Ref. #5-7)
❺	12 086 39-S	1	Screw-Pan Head (W/Loctite)
❻	12 089 11-S	1	Spring-Control, Speed
❼	12 089 23-S	1	Spring-Return, Choke
❽	12 089 19-S	1	Spring-Governor
❾	12 755 83-S	1	Governor Lever Kit (Incl. Ref. #10-12)
❿	12 100 07-S	1	Nut-HF
⓫	52 211 04-S	1	Screw
⓬	12 090 28-S	1	Lever-Governor
⓭	25 158 08-S	1	Bushing-Retaining, Linkage
⓮	12 079 01-S	1	Linkage-Throttle
⓯	25 158 11-S	1	Bushing-Linkage
⓰	12 079 07-S	1	Linkage-Choke

--	--	--	--

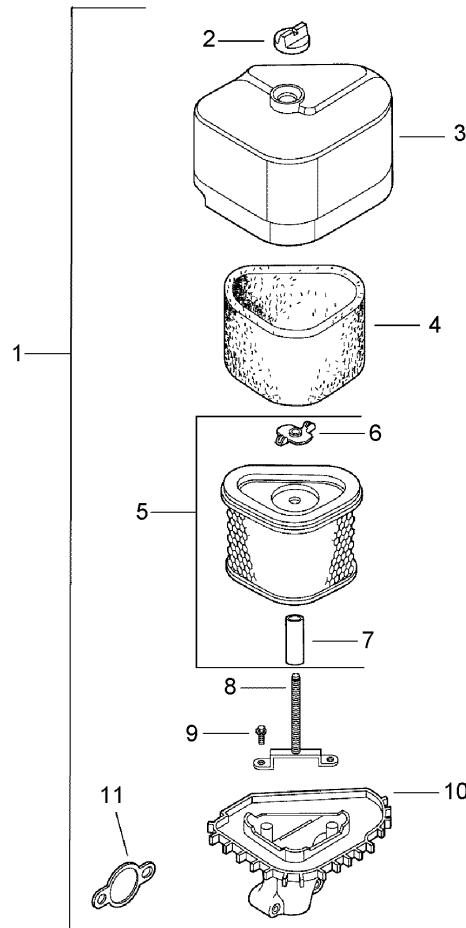

Air Intake and Filtration Assembly Kohler CV13T 21540

Ref	Part No.	Qty.	Description				
1	12 743 04-S	1	Air Cleaner Kit (Incl. Ref. #2-11)				
2	25 341 04-S	1	Knob-Cover				
3	12 096 44-S	1	Cover-Cleaner, Air				
4	12 083 12-S	1	Element-Precleaner				
5	12 083 10-S	1	Element-Cleaner, Air (Incl. Ref. #6)				
6	12 100 01-S	1	Nut-Wing				
7	12 032 11-S	1	Seal				
8	12 072 04-S	1	Stud				
9	12 086 01-S	2	Screw				
10	12 094 14-S	1	Base-Cleaner, Air				
11	12 041 02-S	1	Gasket-Cleaner, Air				
11	12 113 04-S	1	Decal-Cleaner, Air				

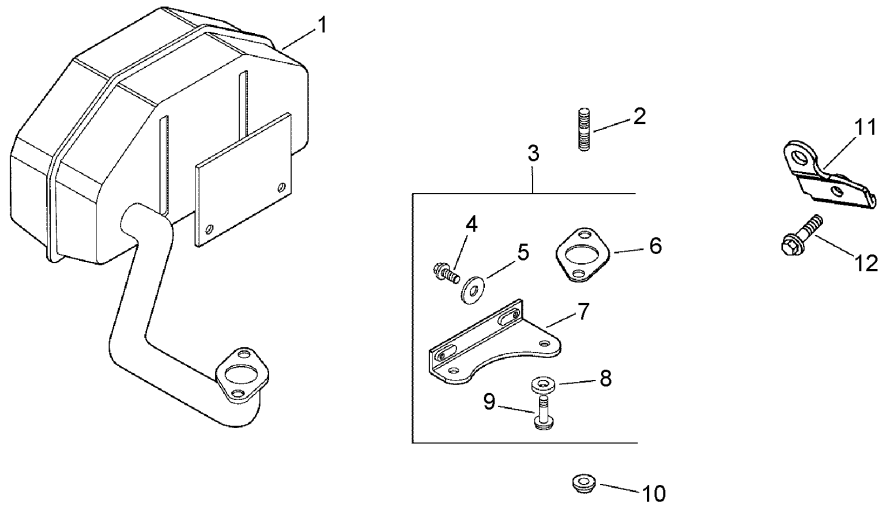

Exhaust Assembly Kohler CV13T 21540

Ref	Part No.	Qty.	Description
1	12 068 35-S	1	Muffler
2	25 072 04-S	2	Stud (M8X1.25X33)
3	12 755 30-S	1	Bracket-Kit (Incl. Ref. #4-9)
4	M-650012-S	2	Screw-HF (M6X1.0X12)
5	X-25-52-S	2	Washer
6	12 041 03-S	1	Gasket-Manifold, Exhaust
7	12 126 55-S	1	Bracket-Muffler
8	12 468 01-S	1	Washer
9	12 086 13-S	1	Screw-HF (M8X1.25X 50)
10	M-841080-S	1	Nut-HF (M8X1.25)
11	12 126 87-S	1	Bracket-Strap, Lifting
12	M-645020-S	2	Screw-HF (M6X1.0X20)
13	12 522 33	1	Shortblock
14	12 755 93-S	1	Gasket Set

--	--	--	--

NOTES

