



Dingo[®] TX 413 Compact Utility Loader

Model No. 22308—260000001 and Up

Operator's Manual



Warning



CALIFORNIA

Proposition 65 Warning

The engine exhaust from this product contains chemicals known to the State of California to cause cancer, birth defects, or other reproductive harm.

Important Because in some areas there are local, state, or federal regulations requiring that a spark-arrester be used on engines, a spark-arrester is available as an option for the traction unit. If a spark-arrester is required, contact your Toro dealer. Genuine Toro approved spark-arresters are approved by the USDA Forestry Service. It is a violation of the State of California PRC Section 4442 to use or operate the engine on any forest-covered, brush-covered, or grass-covered land, unless the engine is equipped with a spark-arrester, maintained in working order, or the engine is restricted, equipped, and maintained for the prevention of fire.

This spark ignition system complies with Canadian ICES-002.

Ce système d'allumage par étincelle de véhicule est conforme à la norme NMB-002 du Canada.

The enclosed Engine Owner's Manual is supplied for information regarding The U.S. Environmental Protection Agency (EPA) and the California Emission Control Regulation of emission systems, maintenance and warranty.

Keep this engine Owner's Manual with your unit. Should this engine Owner's Manual become damaged or illegible, replace immediately. Replacements may be ordered through the engine manufacturer.

Contents

	Page
Introduction	2
Safety	3
Safe Operating Practices	3
Slope Chart	6
Safety and Instruction Decals	7
Setup	8
Loose Parts	8
Charging the Battery	9
Specifications	9
Attachments	9
Stability Data	10

	Page
Before Operating	11
Adding Fuel	11
Checking the Oil Level	12
Removing Debris from the Traction Unit	12
Checking the Hydraulic Fluid	12
Operation	13
Traction Unit Overview	13
Controls	14
Starting and Stopping the Engine	16
Stopping the Traction Unit	17
Moving a Non-functioning Traction Unit	17
Using the Cylinder Lock	18
Using Attachments	19
Securing the Traction Unit for Transport	21
Lifting the Traction Unit	21
Maintenance	22
Recommended Maintenance Schedule	22
Accessing the Engine and Internal Components	23
Adjusting the Controls	24
Servicing the Air Cleaner	25
Servicing the Engine Oil	26
Servicing the Tracks	27
Servicing the Spark Plugs	29
Greasing the Traction Unit	30
Draining the Fuel Tank	32
Servicing the Hydraulic System	32
Servicing the Battery	33
Replacing the Fuses	34
Storage	35
Troubleshooting	36
Schematics	37
Evaporative Emission Control Warranty Statement	39
The Toro Dingo® Product Line Warranty	40

Introduction

Read this manual carefully to learn how to operate and maintain your product properly. The information in this manual can help you and others avoid injury and product damage. Although Toro designs and produces safe products, you are responsible for operating the product properly and safely.

You may contact Toro directly at www.Toro.com for product and accessory information, help finding a dealer, or to register your product.

Whenever you need service, genuine Toro parts, or additional information, contact an Authorized Service Dealer or Toro Customer Service and have the model and

serial numbers of your product ready. Figure 1 illustrates the location of the model and serial numbers on the product.

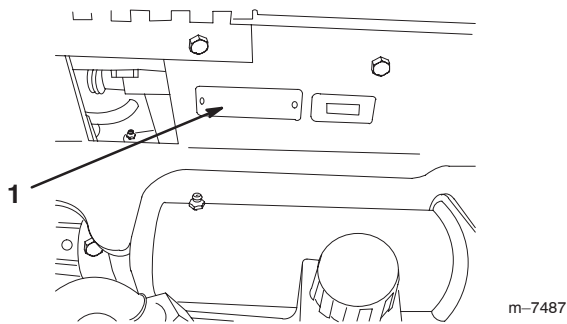

Figure 1

1. Model and serial number plate

For your convenience, write the product model and serial numbers in the space below.

<p>Model No: _____</p> <p>Serial No. _____</p>
--

This manual identifies potential hazards and has special safety messages that help you and others avoid personal injury and even death. **Danger**, **Warning**, and **Caution** are signal words used to identify the level of hazard. However, regardless of the hazard, be extremely careful.

Danger signals an extreme hazard that *will* cause serious injury or death if you do not follow the recommended precautions.

Warning signals a hazard that *may* cause serious injury or death if you do not follow the recommended precautions.

Caution signals a hazard that may cause minor or moderate injury if you do not follow the recommended precautions.

This manual uses two other words to highlight information. **Important** calls attention to special mechanical information and **Note:** emphasizes general information worthy of special attention.

Safety

Improper use or maintenance by the operator or owner can result in injury. To reduce the potential for injury, comply with these safety instructions and always pay attention to the safety alert ⚠ symbol, which means CAUTION, WARNING, or DANGER—“personal safety instruction.” Failure to comply with the instruction may result in personal injury or death.

Safe Operating Practices

This product is capable of amputating hands and feet. Always follow all safety instructions to avoid serious injury or death.

⚠ Warning ⚠
<p>Engine exhaust contains carbon monoxide, an odorless, deadly poison that can kill you.</p> <p>Do not run the engine indoors or in an enclosed area.</p>

Training

- Read the Operator’s Manual and other training material. If the operator(s) or mechanic(s) can not read English, it is the owner’s responsibility to explain this material to them.
- Become familiar with the safe operation of the equipment, operator controls, and safety signs.
- All operators and mechanics should be trained. The owner is responsible for training the users.
- Never let children or untrained people operate or service the equipment. Local regulations may restrict the age of the operator.
- The owner/user can prevent and is responsible for accidents or injuries occurring to himself or herself, other people or property.

Preparation

- Evaluate the terrain to determine what accessories and attachments are needed to properly and safely perform the job. Only use accessories and attachments approved by the manufacturer.
- Wear appropriate clothing including hard hat, safety glasses, long pants, safety shoes, and ear protection. Long hair, loose clothing or jewelry may get tangled in moving parts.
- Inspect the area where the equipment is to be used and remove all objects such as rocks, toys, and wire which can be thrown by the machine.
- Use extra care when handling gasoline and other fuels. They are flammable and vapors are explosive.
 - Use only an approved container
 - Never remove the gas cap or add fuel with the engine running. Allow the engine to cool before refueling. Do not smoke.
 - Never refuel or drain the machine indoors.

- Check that the operator's presence controls, safety switches, and shields are attached and functioning properly. Do not operate unless they are functioning properly.

Operation

- Never run an engine in an enclosed area.
- Only operate in good light, keeping away from holes and hidden hazards.
- Be sure all drives are in neutral and parking brake is engaged before starting the engine. Only start the engine from the operator's position.
- Slow down and use extra care on hillsides. Be sure to travel in the recommended direction on hillsides. Turf conditions can affect the machine's stability.
- Slow down and use caution when making turns and when changing directions on slopes.
- Never operate with the guards not securely in place. Be sure all interlocks are attached, adjusted properly, and functioning properly.
- Do not change the engine governor setting or overspeed the engine.
- Stop on level ground, lower implements, disengage the auxiliary hydraulics, engage parking brake, shut off the engine before leaving the operator's position for any reason.
- Keep hands and feet away from moving attachments.
- Look behind and down before backing up to be sure of a clear path.
- Never carry passengers and keep pets and bystanders away.
- Slow down and use caution when making turns and crossing roads and sidewalks.
- Do not operate the machine under the influence of alcohol or drugs
- Use care when loading or unloading the machine into a trailer or truck
- Use care when approaching blind corners, shrubs, trees, or other objects that may obscure vision.
- Read all attachment manuals.
- Ensure that the area is clear of other people before operating the traction unit. Stop the traction unit if anyone enters the area.
- Never leave a running traction unit unattended. Always lower the loader arm, stop the engine, set the parking brake, and remove the key before leaving.
- Do not exceed the rated operating capacity, as the traction unit may become unstable which may result in loss of control.
- Do not carry a load with the arm raised. Always carry loads close to the ground.
- Do not over-load the attachment and always keep the load level when raising the loader arm. Logs, boards, and other items could roll down the loader arm, injuring you.
- Never jerk the controls; use a steady motion.
- Watch for traffic when operating near or crossing roadways.
- Do not touch parts which may be hot from operation. Allow them to cool before attempting to maintain, adjust, or service.
- Check for overhead clearances (i.e. branches, doorways, electrical wires) before driving under any objects and do not contact them.
- Before digging, have the area marked for underground utilities, and do not dig in marked areas.
- Locate the pinch point areas marked on the traction unit and attachments and keep hands and feet away from these areas.

Slope Operation

Slopes are a major factor related to loss-of-control and tip-over accidents, which can result in severe injury or death. All slopes require extra caution.

- Do not operate the traction unit on hillsides or slopes exceeding the angles recommended in the Stability Data section, page 10, and those in the attachment operator's manual. See also the slope chart on page 6.
- **Operate up and down slopes with the heavy end of the traction unit uphill.** Weight distribution changes. An empty bucket will make the rear of the traction unit the heavy end, and a full bucket will make the front of the traction unit the heavy end. Most other attachments will make the front of traction unit the heavy end.
- Raising the loader arm on a slope will affect the stability of the machine. Whenever possible, keep the loader arm in the lowered position when on slopes.
- Removing an attachment on a slope will make the rear of the traction unit heavy. Refer to the Stability Data section, page 10, to determine whether the attachment can be safely removed on the slope.
- Remove obstacles such as rocks, tree limbs, etc. from the work area. Watch for holes, ruts, or bumps, as uneven terrain could overturn the traction unit. Tall grass can hide obstacles.

- Use only Toro-approved attachments. Attachments can change the stability and the operating characteristics of the traction unit. Warranty may be voided if used with unapproved attachments.
- Keep all movements on slopes slow and gradual. Do not make sudden changes in speed or direction.
- Avoid starting or stopping on a slope. If the traction unit loses traction, proceed slowly, straight down the slope.
- Avoid turning on slopes. If you must turn, turn slowly and keep the heavy end of the traction unit uphill.
- Do not operate near drop-offs, ditches, or embankments. The traction unit could suddenly turn over if a track goes over the edge of a cliff or ditch, or if an edge caves in.
- Do not operate on wet grass. Reduced traction could cause sliding.
- Do not park the traction unit on a hillside or slope without lowering the attachment to the ground, setting the parking brake, and chocking the tracks.
- Keep all parts in good working condition and all hardware tightened. Replace all worn or damaged decals.
- If any maintenance or repair requires the loader arm to be in the raised position, secure the arm in the raised position with the hydraulic cylinder lock.
- Secure the loader arm valve with the loader valve lock anytime you need to stop the machine with the loader arm raised.
- Keep nuts and bolts tight. Keep equipment in good condition.
- Never tamper with safety devices.
- Keep the traction unit free of grass, leaves, or other debris build-up. Clean up oil or fuel spillage. Allow the traction unit to cool before storing.
- Use extra care when handling gasoline and other fuels. They are flammable and vapors are explosive.
 - Use only an approved container.
 - Never remove the gas cap or add fuel when the engine is running. Allow the engine to cool before refueling. Do not smoke.
 - Never refuel the traction unit indoors.
 - Never store the traction unit or fuel container inside where there is an open flame, such as near a water heater or furnace.
 - Never fill a container while it is inside a vehicle, trunk, pick-up bed, or any surface other than the ground.
 - Keep container nozzle in contact with the tank during filling.
- Stop and inspect the equipment if you strike an object. Make any necessary repairs before restarting.
- Use only genuine Toro replacement parts to ensure that original standards are maintained.
- Battery acid is poisonous and can cause burns. Avoid contact with skin, eyes, and clothing. Protect your face, eyes, and clothing when working with a battery.
- Battery gases can explode. Keep cigarettes, sparks and flames away from the battery.
- Keep your body and hands away from pin hole leaks or nozzles that eject high pressure hydraulic fluid. Use cardboard or paper to find hydraulic leaks; never use your hands. Hydraulic fluid escaping under pressure can penetrate skin and cause injury requiring surgery within a few hours by a qualified surgeon or gangrene may result.

Maintenance and Storage

- Disengage the auxiliary hydraulics, lower the attachment, set the parking brake, stop the engine, and remove the key. Wait for all movement to stop before adjusting, cleaning, or repairing.
- Clean debris from attachments, drives, mufflers, and engine to help prevent fires. Clean up oil or fuel spillage.
- Let the engine cool before storing and do not store near flame.
- Do not store fuel near flames or drain indoors.
- Park the machine on level ground. Never allow untrained personnel to service the machine.
- Use jack stands to support components when required.
- Carefully release pressure from components with stored energy.
- Disconnect the battery or remove the spark plug wires before making any repairs. Disconnect the negative terminal first and the positive last. Reconnect positive first and negative last.
- Keep hands and feet away from moving parts. If possible, do not make adjustments with the engine running.
- Charge batteries in an open well ventilated area, away from spark and flames. Unplug the charger before connecting or disconnecting it from the battery. Wear protective clothing and use insulated tools.

Slope Chart

Note: This page may be copied for personal use only.

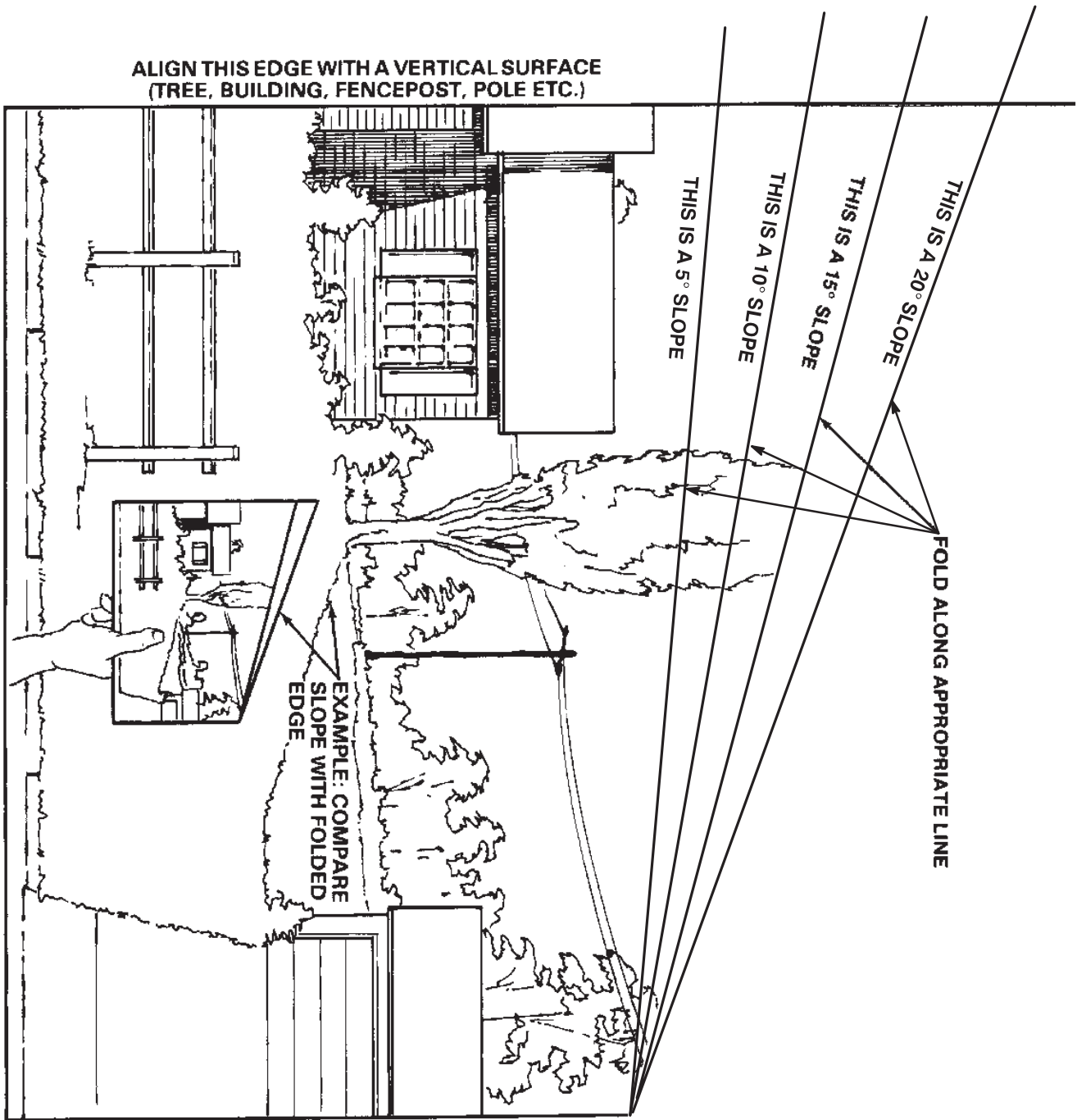

M-4402

Safety and Instruction Decals



Safety decals and instructions are easily visible to the operator and are located near any area of potential danger. Replace any decal that is damaged or lost.



106-9450

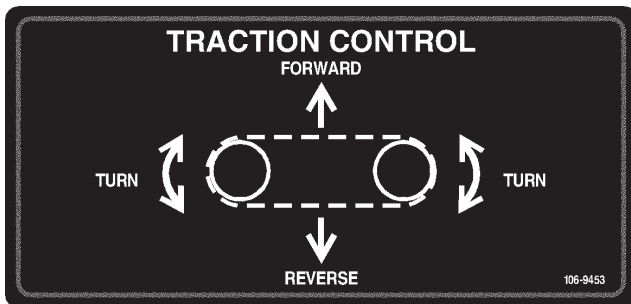

106-9453



100-6141



98-5954



100-6101



80-9350



100-6135



105-8432



104-2838

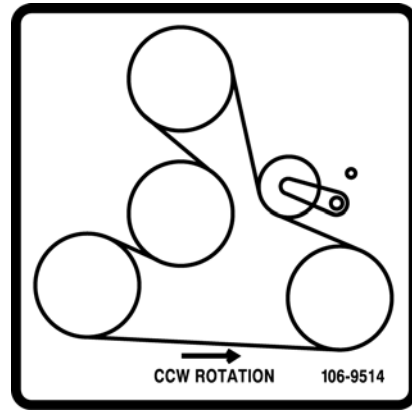

106-9514



1



2

93-9084

1. Lift point

2. Tie-down point

Setup

Note: Determine the left and right sides of the machine from the normal operating position.

Loose Parts

Note: Use the chart below to verify all parts have been shipped.

Description	Qty.	Use
Battery post bolt	2	Connect the battery.
Battery post nut	2	
Engine Manual	1	Read/watch to learn important information about your product.
Training video	1	
Hydraulic filter	1	Retain for future use.
Ignition key	2	
Hood key	2	
Plug wrench	1	

Charging the Battery

Warning

CALIFORNIA
Proposition 65 Warning

Battery posts, terminals, and related accessories contain lead and lead compounds, chemicals known to the State of California to cause cancer and reproductive harm. Wash hands after handling.

1. Open the rear access cover; refer to Opening the Rear Access Cover, page 23.
2. Remove post caps from the battery posts.
3. Connect a battery charger to the battery posts (Fig. 2). Charge the battery at a rate of 6 to 10 amperes for a minimum of 1 hour (12 volts).

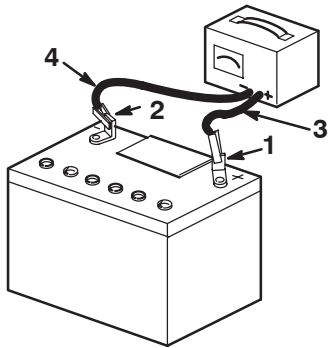

1254

Figure 2

- | | |
|------------------|---------------------------|
| 1. Positive post | 3. Charger red (+) wire |
| 2. Negative post | 4. Charger black (-) wire |

Warning

Charging the battery produces gasses that can explode.

Never smoke near the battery and keep sparks and flames away from battery.

4. When the battery is fully charged, disconnect the charger from the electrical outlet and from the negative and positive battery posts (Fig. 2).
5. Install the battery cables to the positive and negative posts of the battery using the battery post bolts and nuts provided.
6. Ensure that the protective boot covers the positive battery post.
7. Close the rear access cover.

Specifications

Specifications and design are subject to change without notice.

Width	34 inches (86 cm)
Length	67.8 inches (172.2 cm)
Height	44.6 inches (113.3 cm)
Weight	1365 lb (619.2 Kg)
Operating capacity	420 lb (190.5 Kg)
Tipping capacity	1200 lb (544 Kg)
Wheelbase	31.2 inches (79 cm)
Dump height (with narrow bucket)	30.6 inches (77.2 cm)
Reach—fully raised (with narrow bucket)	21.5 inches (54.6 cm)
Height to hinge pin (narrow bucket in the highest position)	50.8 inches (129 cm)

Attachments



A selection of approved attachments are available for use with the traction unit. These attachments allow you to perform many different functions with the traction unit such as hauling materials, digging holes, grading, and more. Contact your Toro dealer for a list of all approved attachments and accessories.

Important Use only Toro-approved, Dingo TX 413 attachments.

Stability Data

The following tables list the maximum slope recommended for the traction unit in the positions listed in the tables. Slopes over the listed degree may cause the traction unit to become unstable. The data in the tables assume that the loader arm are fully lowered; raised arm may affect the stability.

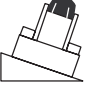

In each attachment manual is a set of three stability ratings, one for each hill position. To determine the maximum slope you can traverse with the attachment installed, find the degree of slope that corresponds to the stability ratings of the attachment. Example: If the attachment has a Front Uphill rating of B, a Rear Uphill rating of D, and a Side Uphill rating of C, then you could drive forward up a 20° slope, rearward up a 12° slope, or sideways on a 15° slope, as listed in the following table.

Configuration	Maximum Recommended Slope when Operating with:		
	Front Uphill 	Rear Uphill 	Side Uphill 
Traction unit without attachment	12°	20°	19°
Traction unit with an attachment rated with one of the following stability ratings for each slope position:			
A	25°	25°	22°
B	20°	20°	19°
C	18°	16°	15°
D	12°	12°	12°
E	5°	5°	5°

Before Operating

Before operating, check the fuel and oil level, and remove debris from the traction unit. Also, ensure that the area is clear of people and debris. You should also know and have marked the locations of all utility lines.

Adding Fuel

 **Danger** 

In certain conditions, gasoline is extremely flammable and highly explosive. A fire or explosion from gasoline can burn you and others and can damage property.

- **Fill the fuel tank outdoors, in an open area, when the engine is cold. Wipe up any gasoline that spills.**
- **Do not fill the fuel tank completely full. Add gasoline to the fuel tank until the level is 1/4 to 1/2 inch (6 to 13 mm) below the bottom of the filler neck. This empty space in the tank allows gasoline to expand.**
- **Never smoke when handling gasoline, and stay away from an open flame or where gasoline fumes may be ignited by a spark.**
- **Store gasoline in an approved container and keep it out of the reach of children. Never buy more than a 30-day supply of gasoline.**
- **Always place gasoline containers on the ground away from your vehicle before filling.**
- **Do not fill gasoline containers inside a vehicle or on a truck or trailer bed because interior carpets or plastic truck bed liners may insulate the container and slow the loss of any static charge.**
- **When practical, remove gas-powered equipment from the truck or trailer and refuel the equipment with its wheels on the ground.**
- **If this is not possible, then refuel such equipment on a truck or trailer from a portable container, rather than from a gasoline dispenser nozzle.**
- **If a gasoline dispenser nozzle must be used, keep the nozzle in contact with the rim of the fuel tank or container opening at all times until fueling is complete.**

Use unleaded gasoline (87 pump octane minimum). Leaded, regular gasoline may be used if unleaded is not available.

Important Do not use methanol, gasoline containing methanol, or gasohol containing more than 10% ethanol because the fuel system could be damaged. Do not mix oil with gasoline.

Using Stabilizer/Conditioner

Use a fuel stabilizer/conditioner in the traction unit to provide the following benefits:

- Keeps gasoline fresh during storage of 90 days or less. For longer storage it is recommended that the fuel tank be drained.
- Cleans the engine while it runs
- Eliminates gum-like varnish buildup in the fuel system, which causes hard starting

Important Do not use fuel additives containing methanol or ethanol.

Add the correct amount of gas stabilizer/conditioner to the gas.

Note: A fuel stabilizer/conditioner is most effective when mixed with fresh gasoline. To minimize the chance of varnish deposits in the fuel system, use fuel stabilizer at all times.

Filling the Fuel Tank

1. Park the traction unit on a level surface, lower the loader arm, and stop the engine.
2. Remove the key and allow the engine to cool.
3. Clean around the fuel tank cap and remove it (Fig. 3).

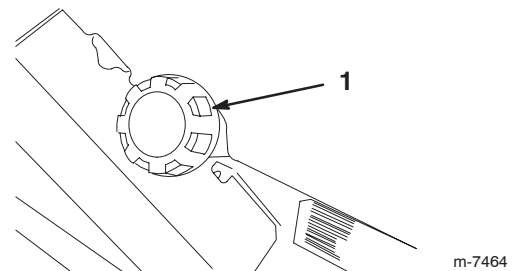

Figure 3

1. Fuel cap

4. Add unleaded gasoline to the fuel tank, until the level is 1/4-1/2 inch below the bottom of the filler neck (Fig. 4).

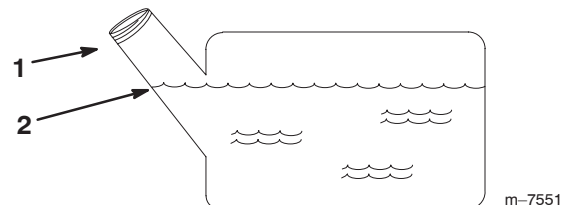

Figure 4

1. Filler neck
2. Fill to 1/4-1/2 inch below filler neck

Important This space in the tank allows gasoline to expand. Do not fill the fuel tank completely full (Fig. 4).

5. Install the fuel tank cap securely.
6. Wipe up any gasoline that may have spilled.

Checking the Oil Level

1. Park the traction unit on a level surface, lower the loader arm, and stop the engine.
2. Remove the key and allow the engine to cool.
3. Clean around the oil dipstick (Fig. 5).

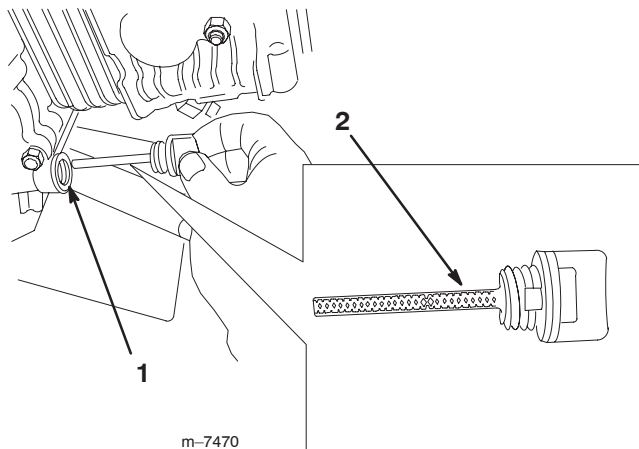

Figure 5

1. Oil filler hole
2. Oil dipstick

4. Remove the dipstick and wipe the end clean (Fig. 5).
5. Slide the dipstick fully into the dipstick tube without threading it into the filler neck (Fig. 5).
6. Pull the dipstick out and look at the end. There should be oil on the dipstick (Fig. 6).

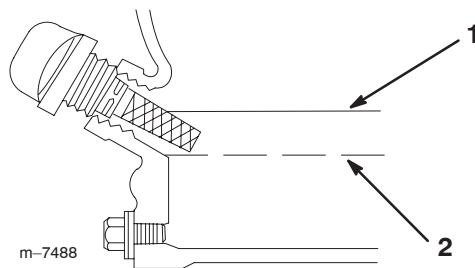

Figure 6

Oil Pan Cross-section

1. Maximum oil level
2. Low oil level

7. If there is no or little oil on the dipstick, add 10w30 engine oil to the filler hole until it comes to the edge of the filler hole (Fig. 5 and 6).
8. Replace the dipstick.

Removing Debris from the Traction Unit

Important Operating the engine with blocked screens, dirty or plugged cooling fins, and/or cooling shrouds removed, will result in engine damage from overheating.

1. Park the traction unit on a level surface, lower the loader arm, and stop the engine.
2. Remove the key and allow the engine to cool.
3. Open the hood; refer to Opening the Hood, page 23.
4. Clean any debris from the front and side screens.
5. Wipe away debris from the air cleaner.
6. Clean any debris build-up on the engine and in the oil cooler fins with a brush or blower.

Important It is preferable to blow dirt out, rather than washing it out. If water is used, keep it away from electrical items and hydraulic valves. Do not use a high-pressure washer. High-pressure washing can damage the electrical system and hydraulic valves or deplete grease.

7. Clean debris from the cooler fan grill on the hood.
8. Close the hood.

Checking the Hydraulic Fluid

Check the hydraulic fluid level before the engine is first started and after every 25 operating hours.

Hydraulic Tank Capacity: 10 US gallons (37.8 l)

Use 10W-30 or 15W-40 detergent, diesel engine oil (API service CH-4 or higher).

1. Remove the attachment, if one is installed; refer to Removing an Attachment, page 20.
2. Park the traction unit on a level surface, lower the loader arm, and fully retract the tilt cylinder.
3. Stop the engine, remove the key, and allow the engine to cool.
4. Clean the area around the filler neck of the hydraulic tank (Fig. 7).
5. Remove the cap from the filler neck (Fig. 7).

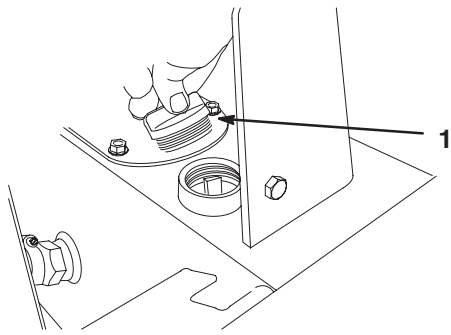

Figure 7

- 1. Filler neck cap

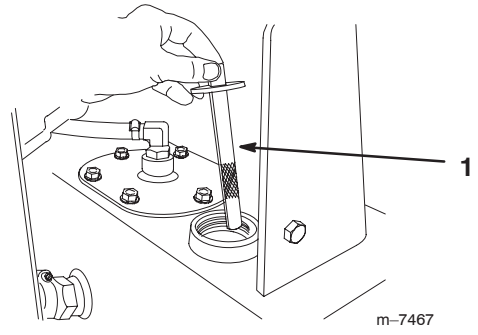

Figure 8

- 1. Dipstick

- 6. Check the fluid level on the dipstick (Fig. 8).
The fluid level should be between the marks on the dipstick.

- 7. If the level is low, add enough fluid to raise it to the proper level.
- 8. Install the cap on the filler neck.

Operation

Traction Unit Overview

Figure 9 contains a front and back view of the traction unit. Familiarize yourself with all of the traction unit components listed in Figure 9.

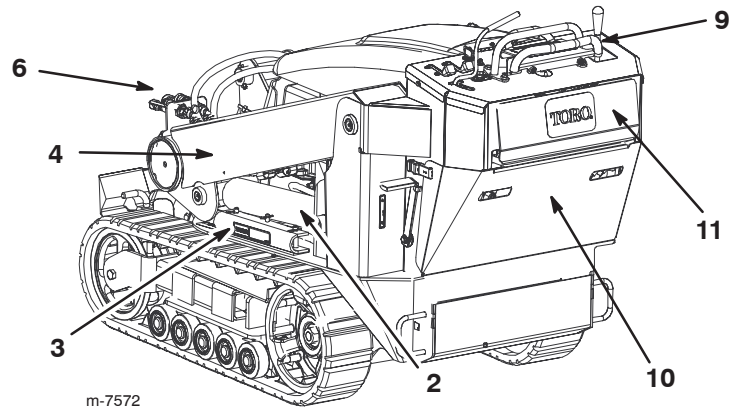
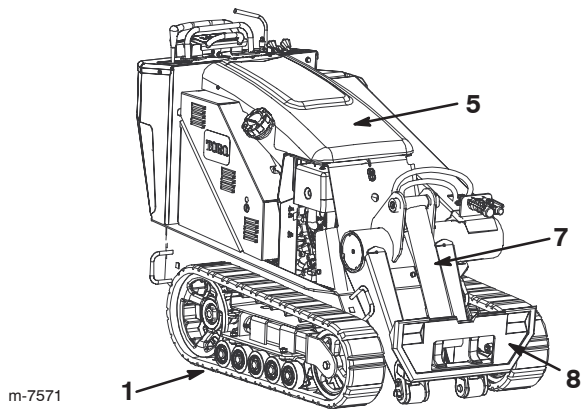

Figure 9

- | | | | |
|------------------|---------------------------------|------------------|--------------------------|
| 1. Track | 4. Loader arm | 7. Tilt cylinder | 10. Rear access cover |
| 2. Lift cylinder | 5. Hood | 8. Mount plate | 11. Reverse safety plate |
| 3. Cylinder lock | 6. Auxiliary hydraulic couplers | 9. Control panel | |

Note: Determine the left and right sides of the machine by standing in the operator's position.

Controls

Become familiar with all the controls (Fig. 10) before you start the engine and operate the traction unit.

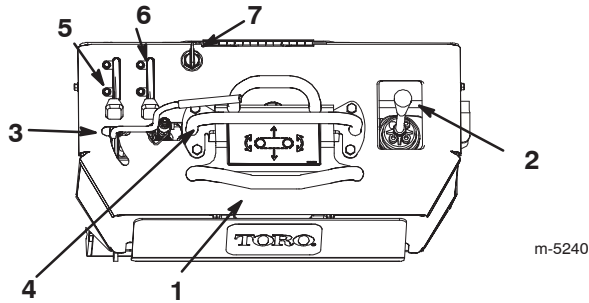

Figure 10

- | | |
|-------------------------------------|-------------------|
| 1. Traction control | 4. Reference bar |
| 2. Loader arm/attachment tilt lever | 5. Throttle lever |
| 3. Auxiliary hydraulics lever | 6. Choke lever |
| | 7. Key switch |

Key Switch

The key switch, used to start and stop the engine, has three positions: off, run, and start.

To start the engine, rotate the key to the start position. Release the key when engine starts and it will move automatically to the run position.

To stop the engine, rotate the key to the off position.

Throttle Lever

Move the control forward to increase the engine speed and rearward to decrease speed.

Choke Lever

Before starting a cold engine, move the choke lever forward. After the engine starts, regulate the choke to keep the engine running smoothly. As soon as possible, move the choke lever all the way rearward.

Note: A warm engine requires little or no choking.

Reference Bar

When driving the traction unit, use the reference bar as a handle and a leverage point for controlling the traction control and the auxiliary hydraulics lever. To ensure smooth, controlled operation, do not take both hands off of the reference bar while operating the traction unit.

Traction Control

To move forward, move the traction control forward. To move rearward, move the traction control rearward (Fig. 11).

To turn, rotate the traction control in the desired direction (Fig. 11).

The farther you move the traction control in any direction, the faster the traction unit will move in that direction.

To stop, release the traction control.

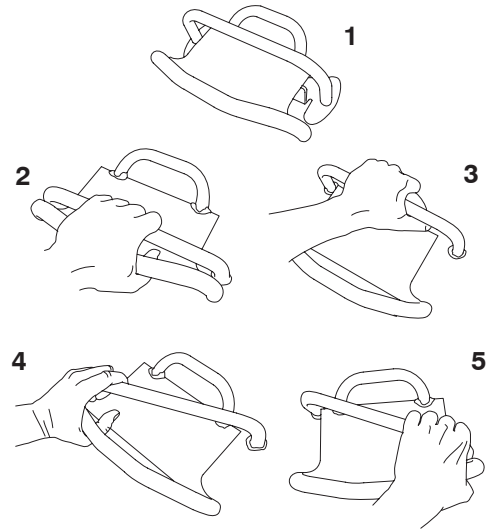

Figure 11

- | | |
|-----------------|---------------|
| 1. Neutral/stop | 4. Turn right |
| 2. Forward | 5. Turn left |
| 3. Reverse | |

Loader Arm/Attachment Tilt Lever

To tilt the attachment forward, slowly move the lever to the right (Fig. 12).

To tilt the attachment rearward, slowly move the lever to the left (Fig. 12).

To lower the loader arm, slowly move the lever forward (Fig. 12).

To raise the loader arm, slowly move the lever rearward (Fig. 12).

You can also push the lever fully forward into a detent position (Fig. 12) to release the loader arm so that the attachment rests on the ground. This allows attachments such as the leveler and the hydraulic blade to follow the contours of the ground (i.e., float) when grading.

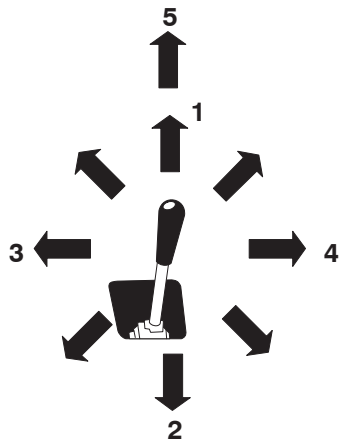

Figure 12

m-4666

- | | |
|---------------------------------|--------------------------------|
| 1. Lower the loader arm | 4. Tilt the attachment forward |
| 2. Raise the loader arm | 5. Detent (Float) position |
| 3. Tilt the attachment rearward | |

By moving the lever to an intermediate position (such as, forward and left), you can move the loader arm and tilt the attachment at the same time.

Auxiliary Hydraulics Lever

To operate a hydraulic attachment in the forward direction, rotate the auxiliary hydraulics lever rearward and pull it down to the reference bar (Fig. 13).

To operate a hydraulic attachment in reverse direction, rotate the hydraulics lever rearward, then move it left into the upper slot (Fig. 13).

If you release the lever while in either the forward position or upper reverse position, the lever will automatically return to the neutral position (Fig. 13).

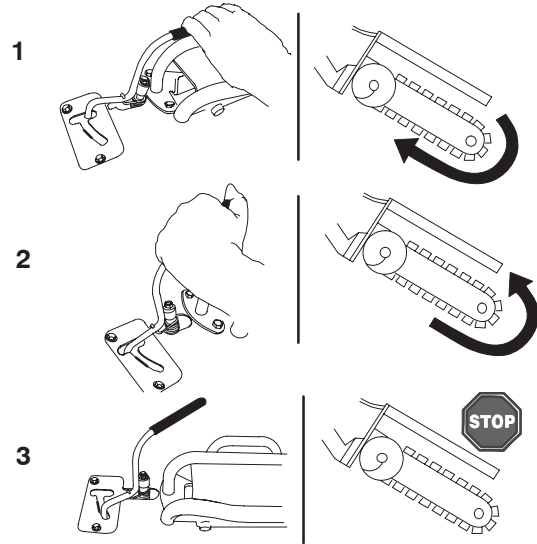

Figure 13

- | | |
|----------------------------|------------|
| 1. Forward flow hydraulics | 3. Neutral |
| 2. Reverse flow hydraulics | |

Parking Brake Lever

To set the parking brake, pull the brake lever out of the retaining bracket and pull the lever rearward and down (Fig. 14).

Note: The traction unit may roll slightly before the brakes engage in the drive sprocket.

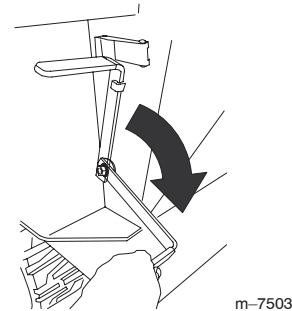

Figure 14

m-7503

To release the brake, pull the lever up and secure it into the retaining bracket.

The Fuel Valve Lever

Important Use the cylinder lock when raising the loader arm to access the fuel valve lever. Refer to the Using the Cylinder Lock section on page 18.

The fuel valve lever opens and closes the passage between the fuel tank and the carburetor. The fuel valve lever is shipped from the factory in the open position.

The traction unit is equipped with an electric fuel solenoid that is connected to the ignition switch. The solenoid automatically shuts the fuel off when the ignition key is in the Off position. **The manual fuel lever should remain in the On position.**

The fuel valve lever is located on the left hand side of the traction unit (Fig. 15). Raise the loader arm and secure it with the cylinder lock to access the lever.

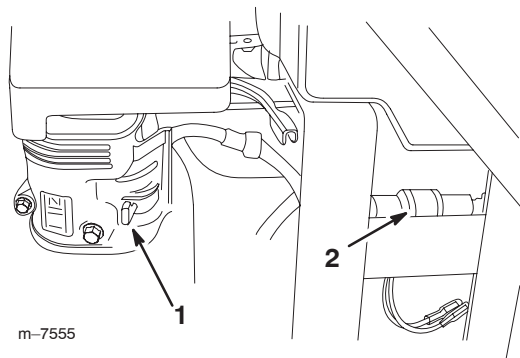

Figure 15

1. Manual fuel valve lever
2. Electric fuel solenoid

The fuel valve lever must be in the On position for the engine to run (Fig. 16).

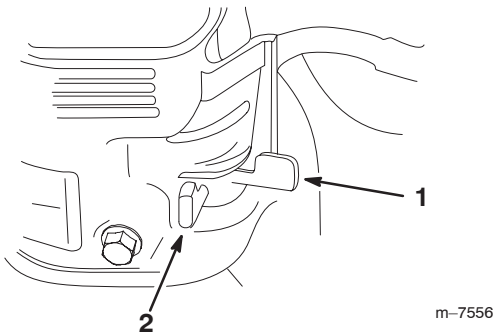

Figure 16

1. Fuel valve in On position
2. Fuel valve in the Off position

Hour Meter

When the engine is off, the hour meter displays the number of hours of operation that have been logged on the traction unit.

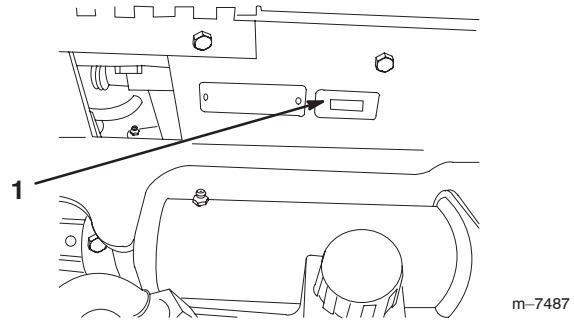

Figure 17

1. Hour meter/tachometer

After the first 8 hours the screen displays CHG OIL to remind you to change the **hydraulic filter**. Every 99 hours thereafter the screen displays CHG OIL to remind you to change the **engine oil**. After every 399 hours, the screen displays SVC to remind you to perform the other maintenance procedures based on a 400 hour schedule. These reminders come on starting three hours prior to the service interval time and flash at regular intervals for six hours.

Starting and Stopping the Engine

Starting the Engine

1. Ensure that the auxiliary hydraulics lever is in neutral.
2. Move the throttle lever between the Fast and Slow positions (Fig 18, A).

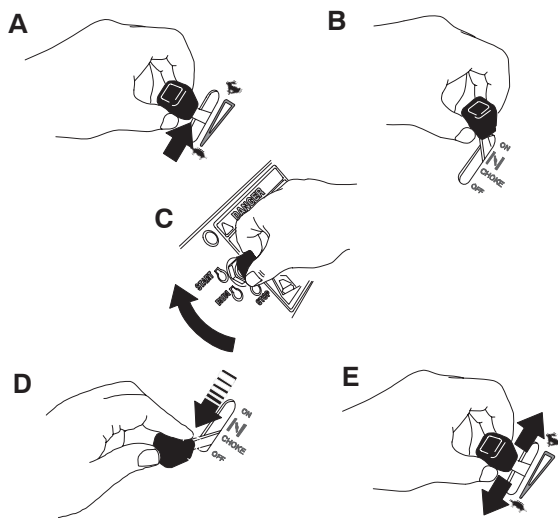

Figure 18

3. Move the choke lever to the On position (Fig 18, B).

Note: A warm or hot engine may not require choking.

4. Turn the ignition key to the start position until the engine starts (Fig 18, C).

Important Do not engage the starter for more than 10 seconds at a time. If the engine fails to start, allow a 30 second cool-down period between attempts. Failure to follow these instructions can burn out the starter motor.

5. Gradually move the choke lever to the Off position (Fig 18, D). If the engine stalls or hesitates, engage the choke again until the engine warms up.
6. Adjust the throttle lever as desired (Fig 18, E).

Important If the engine is run at high speeds when the hydraulic system is cold (i.e., when the ambient air temperature is near freezing or lower), hydraulic system damage could occur. When starting the engine in cold conditions, allow the engine to run in the middle throttle position for 2 to 5 minutes before moving the throttle to fast (rabbit).

Note: If outdoor temperature is below freezing, store the traction unit in a garage to keep it warmer and aid in starting.

Stopping the Engine

1. Move the throttle lever to the slow position (Fig. 19, A).

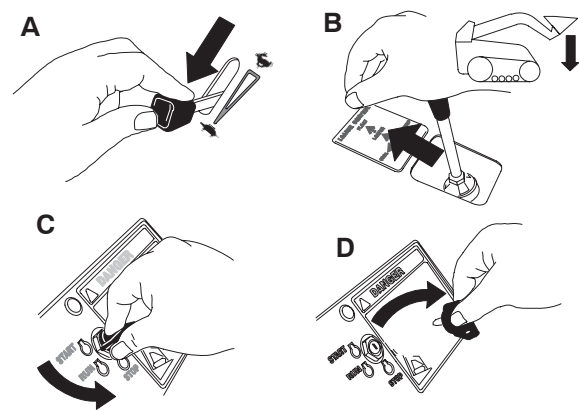

Figure 19

2. Lower the loader arm (Fig. 19, B).
 3. Turn the ignition key to the stop position (Fig. 19, C).
- Note:** If the engine has been working hard or is hot, let it idle for a minute before turning the ignition key off. This helps cool the engine before it is stopped. In an emergency, the engine may be stopped immediately.
4. Remove the ignition key (Fig. 19, D).

Stopping the Traction Unit

To stop the traction unit, release the traction control, move the throttle lever to slow (turtle), lower loader arm to the ground, and stop the engine. Set the parking brake and remove the key.

	Caution	
<p>A child or untrained bystander could attempt to operate the traction unit and be injured.</p> <p>Remove the key from the switch when leaving the traction unit, even if just for a few seconds.</p>		

Moving a Non-functioning Traction Unit

Important Do not tow or pull the traction unit without first opening the tow valves, or the hydraulic system will be damaged.

1. Stop the engine.
2. Open the hood; refer to Opening the Hood, page 23.

- Using a wrench, turn the tow valves (Fig. 20) on the hydraulic pumps twice counter-clockwise.

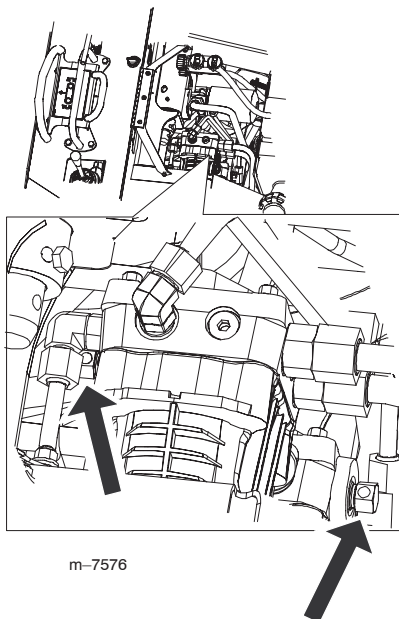

Figure 20

- Close the hood and tow the traction unit as required.
- When the traction unit has been repaired, close the tow valves before operating it.

Using the Cylinder Lock



Warning



The loader arm may lower when in the raised position crushing anyone under them.

Install the cylinder lock before performing maintenance that requires raised loader arm.

Installing the Cylinder Lock

- Remove the attachment.
- Raise the loader arm to the fully raised position.
- Stop the engine.
- Remove the hairpin cotter and clevis pin securing the cylinder lock to the frame (Fig. 22)

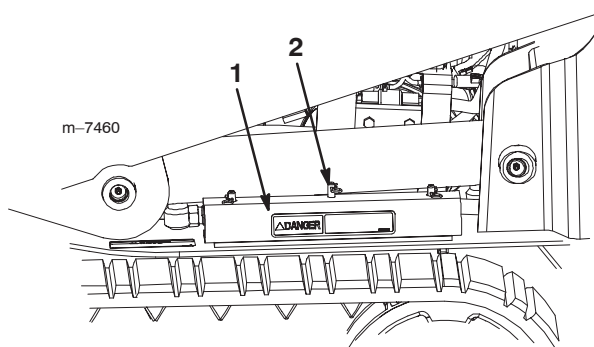

Figure 21

- Cylinder lock
- Clevis and hairpin cotter

- Place the cylinder lock over the cylinder rod and secure it with the clevis pin and hairpin cotter (Fig. 22).

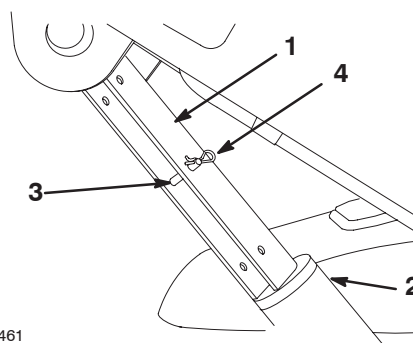

Figure 22

- Cylinder lock
- Lift cylinder
- Clevis pin
- Hairpin cotter

- Slowly lower the loader arm until cylinder lock contacts the cylinder body and rod end.

Removing/Storing the Cylinder Lock

Important Ensure that the cylinder lock is removed from the rod and fully secured in the storage position before operating the traction unit.

- Start the engine.
- Raise the loader arm to the fully raised position.
- Stop the engine.
- Remove the clevis pin and cotter pin securing the cylinder lock.
- Place the cylinder lock in its storage location on the frame and secure it with the clevis pin and hairpin cotter (Fig. 22).

6. Lower the loader arm.

Using Attachments

Connecting an Attachment

Important Use only Toro-approved, Dingo TX 413 attachments. Attachments can change the stability and the operating characteristics of the traction unit. The warranty of the traction unit may be voided if used with unapproved attachments.

Important Before installing the attachment, ensure that the mount plates are free of any dirt or debris and that the pins rotate freely. If the pins do not rotate freely, grease them; refer to Greasing the Traction Unit, page 30.

1. Position the attachment on a level surface with enough space behind it to accommodate the traction unit.
2. Start the engine.
3. Tilt the attachment mount plate forward.
4. Position mount plate into the upper lip of the attachment receiver plate (Fig. 23).

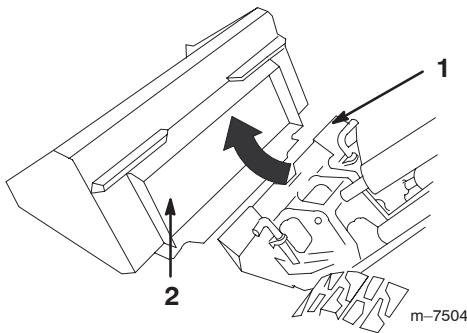

Figure 23

1. Mount plate
2. Receiver plate

5. Raise the loader arm while tilting back the mount plate at the same time.

Important The attachment should be raised enough to clear the ground, and the mount plate should be tilted all the way back.

6. Stop the engine.
7. Engage the quick attach pins, ensuring that they are fully seated in the mount plate (Fig. 24).

Important If the pins do not rotate to the engaged position, the mount plate is not fully aligned with the holes in the attachment receiver plate. Check the receiver plate and clean it if necessary.

⚠
Warning
⚠

If you do not fully seat the quick attach pins through the attachment mount plate, the attachment could fall off of the traction unit, crushing you or bystanders.

Ensure that your quick attach pins are fully seated in the attachment mount plate.

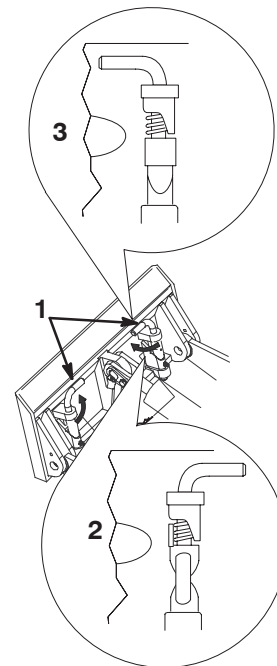

Figure 24

1. Quick attach pins (shown in engaged position)
2. Disengaged position
3. Engaged position

Connecting the Hydraulic Hoses

If the attachment requires hydraulics for operation, connect the hydraulic hoses as follows:

1. Stop the engine.
2. Move the auxiliary hydraulics lever forward, backward, and back to neutral to relieve pressure at the hydraulic couplers.
3. Move the auxiliary hydraulics lever into the detent position.
4. Remove the protective covers from the hydraulic couplers on the traction unit.
5. Clean all foreign matter from the hydraulic couplers.

6. Push the attachment male coupler into the female coupler on the traction unit (Fig. 25).

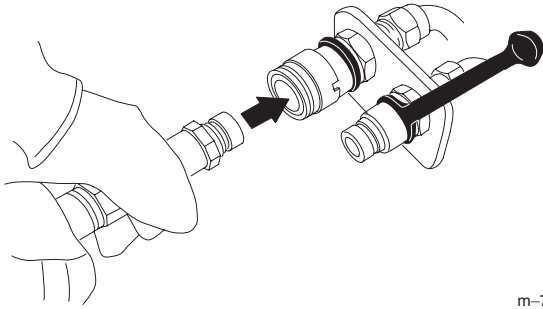

m-7489

Figure 25

7. Push the attachment female coupler onto the male connector on the traction unit (Fig. 26).

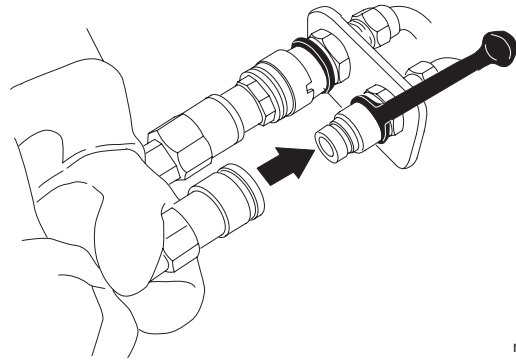

m-7490

Figure 26

Note: When you connect the attachment male coupler first, you will relieve any pressure build up in the attachment.

⚠
Warning
⚠

Hydraulic fluid escaping under pressure can penetrate skin and cause injury. Fluid injected into the skin must be surgically removed within a few hours by a doctor familiar with this form of injury or gangrene may result.

- Keep your body and hands away from pin hole leaks or nozzles that eject high pressure hydraulic fluid.
- Use cardboard or paper to find hydraulic leaks, never use your hands.

⚠
Caution
⚠

Hydraulic couplers, hydraulic lines/valves, and hydraulic fluid may be hot. If you contact hot components you may be burned.

- Wear gloves when operating the hydraulic couplers.
- Allow the traction unit to cool before touching hydraulic components.
- Do not touch hydraulic fluid spills.

8. Confirm that the connection is secure by pulling on the hoses.
9. Move the auxiliary hydraulics lever to neutral.
10. Connect the protective covers of the hydraulic couplers to each other to ensure the inside of the covers stay clean when the unit is in use (Fig. 27).

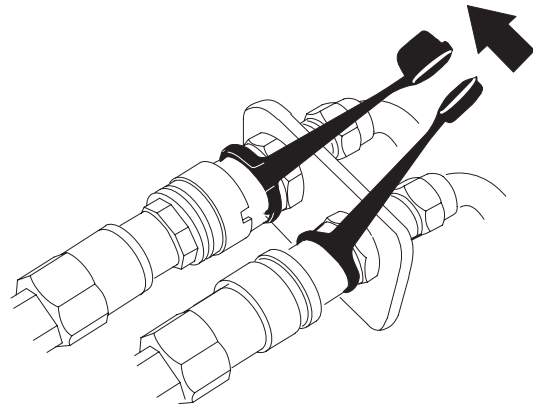

m-7561

Figure 27

Removing an Attachment

1. Lower the attachment to the ground.
2. Stop the engine.
3. Disengage the quick attach pins by turning them to the outside.
4. If the attachment uses hydraulics, move the auxiliary hydraulics lever forward, back and forth, and back to neutral to relieve pressure at the hydraulic couplers.

5. If the attachment uses hydraulics, slide the collar back on the hydraulic couplers and disconnect them.
6. Install the protective covers onto the hydraulic couplers on the traction unit.
7. Start the engine, tilt the mount plate forward, and back the traction unit away from the attachment.

Securing the Traction Unit for Transport

Important Do not operate or drive the traction unit on roadways.

Important When transporting the traction unit on a trailer, always use the following procedure:

1. Lower the loader arm.
2. Stop the engine.
3. Set the parking brake.
4. Secure the traction unit to the trailer with chains or straps using the tie-down/lift loops at the front and rear of the traction unit (Fig. 28 and 29).

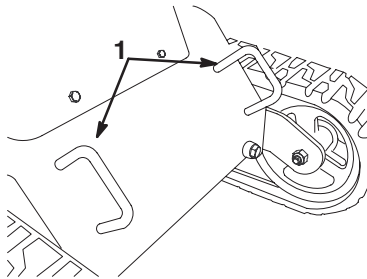

m-7462

Figure 28

1. Front tie-down loops

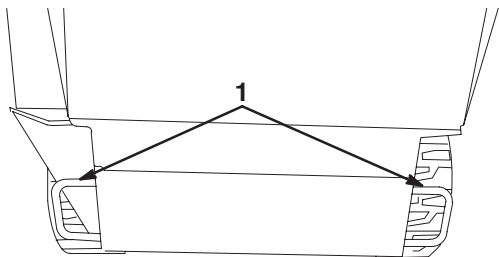

m-7463

Figure 29

1. Rear tie-down loops

Lifting the Traction Unit

You can lift the traction unit using the tie-down/lift loops as lift points (Fig. 28 and 29).

Maintenance

Recommended Maintenance Schedule

Important Refer to your **engine operator's manual** for additional maintenance procedures.

Maintenance Service Interval	Maintenance Procedure
8 hours	<ul style="list-style-type: none"> • Grease the traction unit • Check engine oil level • Check for loose fasteners • Inspect the tracks for damage or wear • Change hydraulic filter after the initial 8-10 operating hours³
25 hours	<ul style="list-style-type: none"> • Check hydraulic oil level⁶ • Inspect hydraulic lines for leaks
50 hours	<ul style="list-style-type: none"> • Clean the foam pre-filter and the paper air filter¹
100 hours	<ul style="list-style-type: none"> • Change engine oil^{1, 2} • Replace the paper air filter¹ • Check battery electrolyte level • Adjust the track tension • Check battery cable connections • Check the spark plug
200 hours	<ul style="list-style-type: none"> • Change hydraulic filter^{1, 3, 5}
300 hours	<ul style="list-style-type: none"> • Replace the spark plug
400 hours	<ul style="list-style-type: none"> • Inspect fuel lines for leaks • Change hydraulic oil and filter¹
Yearly/Storage	<ul style="list-style-type: none"> • Check for loose fasteners • Touch up chipped paint • Adjust the track tension • Check tracks and road wheels • Complete all yearly maintenance procedures specified in the engine operator's manual • Charge the battery and disconnect the cables (storage only) • Drain the gasoline (storage only)

¹More often in dusty, dirty conditions.

²Change oil after the first 50 operating hours.

³Change the hydraulic filter after the first 8–10 operating hours.

⁴For severe duty or rental applications, change every 100 operating hours.

⁵For severe duty or rental applications, change every 200 operating hours.

⁶Check the hydraulic fluid level before using the traction unit for the first time.



Caution



If you leave the key in the ignition switch, someone could accidentally start the engine and seriously injure you or other bystanders.

Remove the key from the ignition and disconnect the wire from the spark plug before you do any maintenance. Set the wire aside so that it does not accidentally contact the spark plug.

Accessing the Engine and Internal Components

Before opening any of the covers, stop the engine and remove the key. Allow the engine to cool before opening any covers.

Opening the Hood

1. Turn the hood latch clockwise and swing the hood up (Fig. 30).

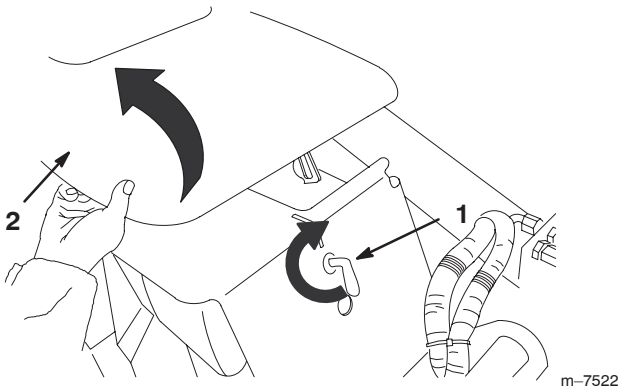

Figure 30

1. Hood latch, turn clockwise
2. Hood, swing up

Closing the Hood

Lower the hood and secure it by pushing down on the front of the hood until it locks in place.

Opening the Rear Access Cover

1. Pull out and forward on the latches on both sides of the traction unit (Fig. 31).

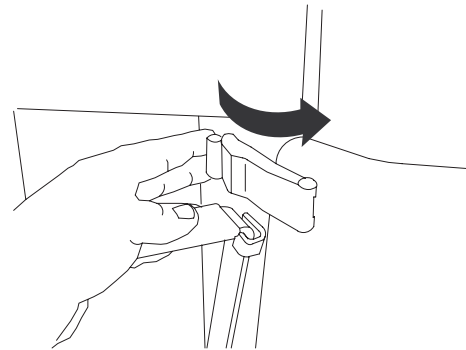

Figure 31

2. Swing the rear access cover down and pull it away from the traction unit (Fig. 31).

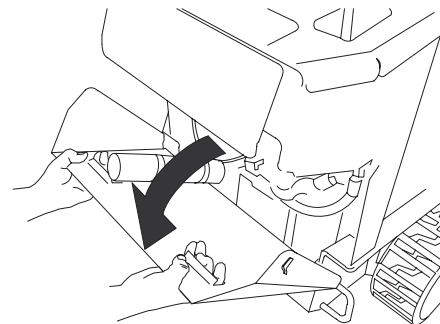

Figure 32

Closing the Rear Access Cover

1. Insert the bottom of the rear access cover into the frame and swing it up.
2. Place the latches over the locking brackets on each side and secure them (Fig. 31).

Adjusting the Controls

The factory adjusts the controls before shipping the traction unit. However, after many hours of use, you may need to adjust the traction control alignment, the neutral position of the traction control, and the tracking of the traction control in the full forward position.

Important To adjust the controls properly, complete each procedure in the order listed.

Adjusting the Traction Control Alignment

If the traction control bar does not rest flush and square with the reference bar when in the full backward position, immediately complete the following procedure:

1. Park the traction unit on a flat surface and lower the loader arm.
2. Stop the engine and remove the key.
3. Pull straight back on the traction control so the front of the control contacts the reference bar (Fig. 33).

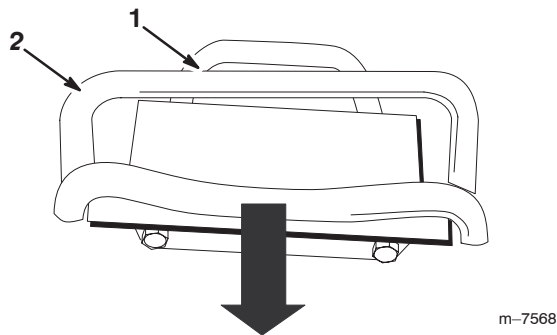

Figure 33

1. Front of the control, out of alignment
2. Reference bar

4. If the front of the traction control does not rest square and flush with the reference bar, loosen the flange nut and bolt in the stem of the traction control (Fig. 34).

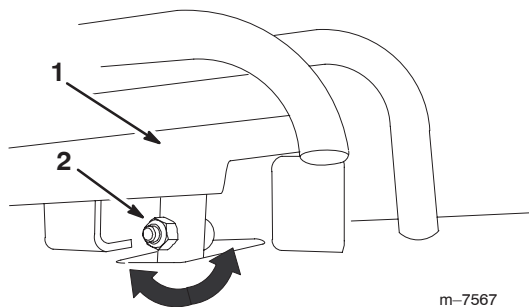

Figure 34

1. Traction control
2. Stem, bolt and nut

5. Adjust the traction control so that it rest flush against the reference bar when it is pulled straight back (Fig. 34 and 35).

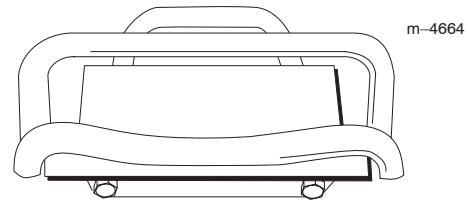

Figure 35

6. Tighten the flange nut and bolt in the traction control stem.

Adjusting the Traction Control Neutral Position

If the traction unit creeps forward or backward when the traction control is in neutral and the unit is warm, immediately complete the following procedure:

1. Lift/support the traction unit so that both tracks are off of the ground.
2. Open the rear access cover; refer to Opening the Rear Access Cover, page 23.
3. Loosen the jam nuts on the traction rods, under the control panel (Fig. 36).

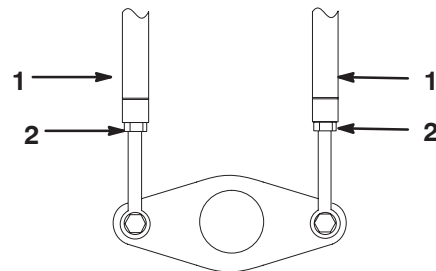

Figure 36

1. Traction rod
2. Jam nut

4. Start the traction unit and set the throttle to about 1/3 open position.



Warning



When the traction unit is running, you could be caught and injured in moving parts or burned on hot surfaces.

Stay away from pinch points, moving parts, and hot surfaces when adjusting the running traction unit.

5. If the **left** track moves, lengthen or shorten the **right** traction rod until the track stops moving.
6. If the **right** track moves, lengthen or shorten the **left** traction rod until the track stops moving.
7. Tighten the jam nuts.
8. Close the rear access cover.
9. Stop the engine and lower the traction unit to the ground.
10. Drive the traction unit in full reverse, checking to see if the unit tracks straight. If it does not, note the direction the traction unit veers. Repeat the adjustment previously described so that it tracks straight in reverse.

Adjusting the Tracking of the Traction Control, Full Forward Position

If the traction unit does not drive straight when you hold the traction control against the reference bar, complete the following procedure:

1. Drive the traction unit with the traction control against the reference bar, noting which direction the traction unit veers.
2. Release the traction control.
3. If the traction unit veers to the **left**, loosen the **right** jam nut and adjust the tracking set screw on the front of the traction control (Fig. 37).
4. If the traction unit veers to the **right**, loosen the **left** jam nut and adjust the tracking set screw on the front of the traction control (Fig. 37).

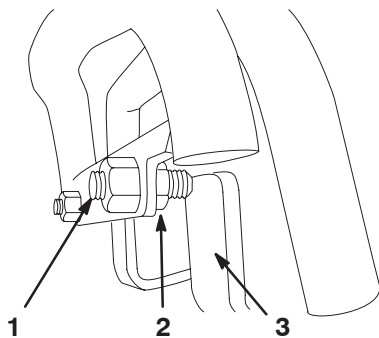

Figure 37

1. Set screw
2. Jam nut
3. Stop

5. Repeat steps 1 through 4 until the traction unit drives straight in the full forward position.

Important Ensure the tracking set screws touch the stops in the full forward position to avoid over stroking the hydraulic pumps.

Servicing the Air Cleaner

Foam Pre-filter: Clean every 50 operating hours.

Paper Filter: Clean every 50 operating hours. Replace after every 100 operating hours.

Note: Service the air cleaner more frequently if operating conditions are extremely dusty or sandy.

Removing the Foam and Paper Filters

1. Lower the loader arm, stop the engine, and remove the key.
2. Open the hood; refer to Opening the Hood, page 23.
3. Clean around the air cleaner to prevent dirt from getting into the engine and causing damage.
4. Remove the wingnut from the air cleaner cover and remove the cover (Fig. 39).

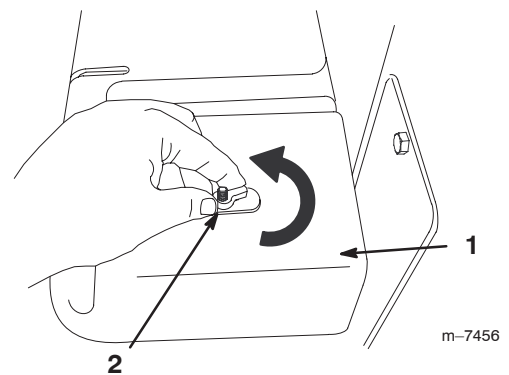

Figure 38

1. Air cleaner cover
2. Wingnut

5. Remove the wingnut from the air filters and remove the filters (Fig. 39).

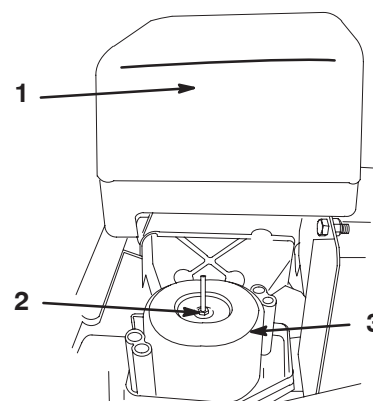

Figure 39

1. Air cleaner cover
2. Wingnut
3. Air filter assembly

- Remove the drain plug (Fig. 41).

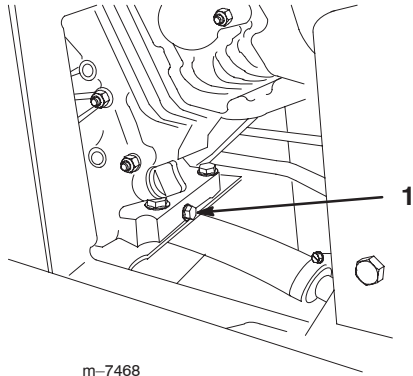

Figure 41

- Oil drain plug

- When the oil has drained completely, replace the plug.

Note: Dispose of the used oil at a certified recycling center.

- Remove the dipstick and slowly pour oil into the filler hole until the oil pours out of the filler hole.

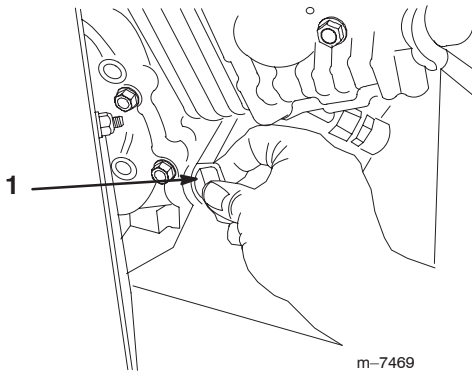

Figure 42

- Dipstick

- Replace and secure the dipstick.

Servicing the Tracks

Check the tracks for excessive wear and clean them periodically. If the tracks are worn, replace them. Check the road wheels yearly.

Cleaning the Tracks

- With a bucket on the loader arm, lower the bucket to the ground so that the front of the traction unit lifts off of the ground a few inches.
- Stop the engine, and remove the key.

- Using a water hose or pressure washer, remove dirt from each track system.

Important Ensure that you use high-pressure water to wash only the track area. Do not use a high-pressure washer to clean the rest of the traction unit. High-pressure washing can damage the electrical system and hydraulic valves or deplete grease.

Important Ensure that you fully clean the road wheels, the tension wheel, and the drive sprocket (Fig. 43). The road wheels should rotate freely when clean.

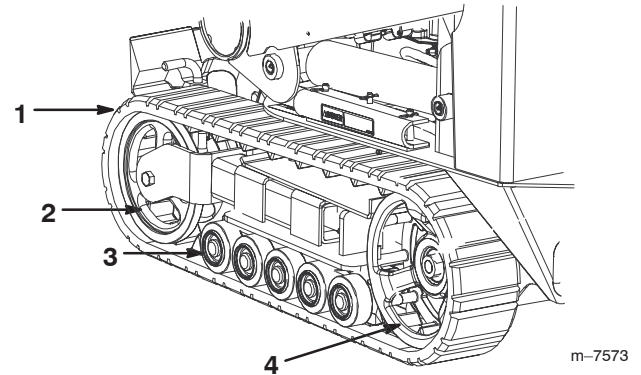

Figure 43

- | | |
|------------------|-------------------|
| 1. Track | 3. Road wheels |
| 2. Tension wheel | 4. Drive Sprocket |

Adjusting the Track Tension

Check and adjust the track tension every 100 operating hours. There should be 2-3/4 inches (7 cm) between the tension nut and the back of the tension tube (Fig. 44). If not, adjust the track tension using the following procedure:

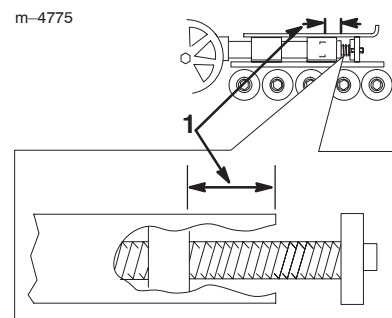

Figure 44

- 2-3/4 inches (7 cm)

- Lower the loader arm, stop the engine, and remove the key.
- Lift/support the side of the unit to be worked on so that the track is off of the ground.

- Remove the locking bolt, spacer, and nut (Fig. 45).

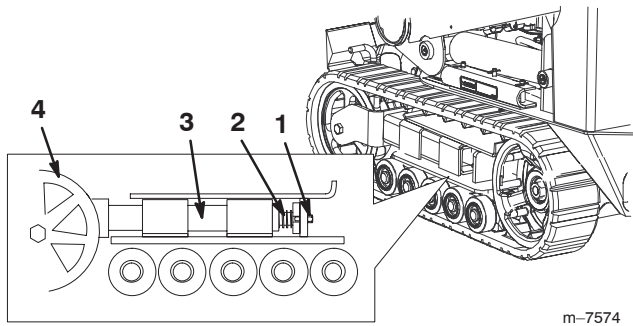

Figure 45

- | | |
|---------------------|------------------|
| 1. Locking bolt | 3. Tension tube |
| 2. Tensioning screw | 4. Tension wheel |

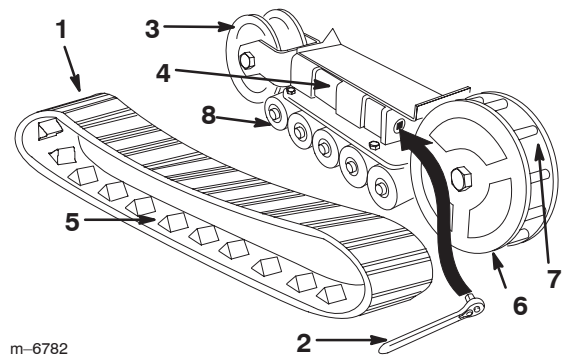

Figure 46

- | | |
|--------------------|--------------------|
| 1. Track | 5. Track lug |
| 2. 1/2 inch socket | 6. Drive sprocket |
| 3. Tension wheel | 7. Sprocket spacer |
| 4. Fork tube | 8. Road wheels |

- Using a 1/2 inch drive socket (Fig. 46), turn the tensioning screw counter-clockwise until the distance between the tension nut and the back of the tension tube (Fig. 44) is 2-3/4 inches (7 cm).
- Align the closest notch in the tension screw to the locking bolt hole and secure the screw with the locking bolt, spacer, and nut (Fig. 45).
- Lower the traction unit to the ground.

Replacing the Tracks

When the tracks are badly worn, replace them.

- Lower the loader arm, stop the engine, and remove the key.
- Lift/support the side of the unit to be worked on so that the track is 3 to 4 inches (7.6 to 10 cm) off of the ground.
- Remove the locking bolt, spacer, and nut (Fig. 45).
- Using a 1/2 inch drive socket, release the drive tension by turning the tensioning screw clockwise (Fig. 45 and 46).

- Push the tension wheel toward the rear of the unit to move the fork tube against the frame (Fig. 46). (If it does not touch the frame, continue turning the tensioning screw until it does.)
- Begin removing the track at the top of the tension wheel, peeling it off of the wheel while rotating the track forwards.
- When the track is off of the tension wheel, remove it from the drive sprocket and road wheels (Fig. 46).
- Beginning at the drive sprocket, coil the new track around the sprocket, ensuring that the lugs on the track fit between the spacers on the sprocket (Fig. 46).
- Push the track under and between the road wheels (Fig. 46).
- Starting at the bottom of the tension wheel, install the track around the wheel by rotating the track rearward while pushing the lugs into the wheel.
- Turn the tensioning screw counter-clockwise until the distance between the tension nut and the back of the fork tube (Fig. 44) is 2-3/4 inches (7 cm).
- Align the closest notch in the tension screw to the locking bolt hole and secure the screw with the locking bolt, spacer, and nut.
- Lower the traction unit to the ground.
- Repeat steps 2 through 13 to replace the other track.

Maintaining the Road Wheels

Check and grease the road wheels every 250 operating hours or yearly.

1. Remove the tracks; refer to Replacing the Tracks, page 28.
2. Remove the 4 bolts securing each lower track guide which contains the road wheels, and remove them (Fig. 47).

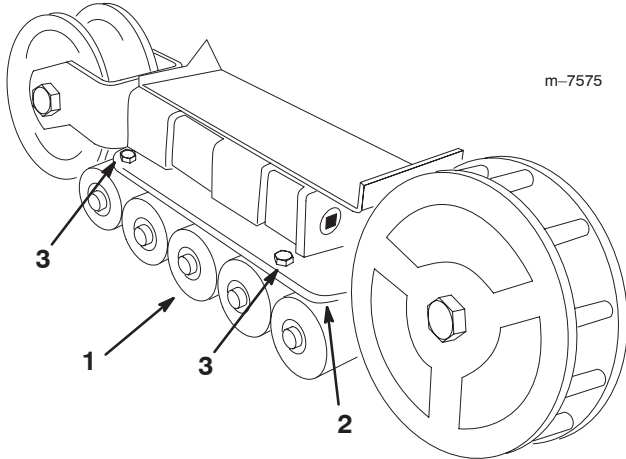

Figure 47

- | | |
|----------------------|---------------------------------------|
| 1. Road wheels | 3. Track guide bolts (only two shown) |
| 2. Lower track guide | |

3. Remove the snap ring and cap from a road wheel (Fig. 48).

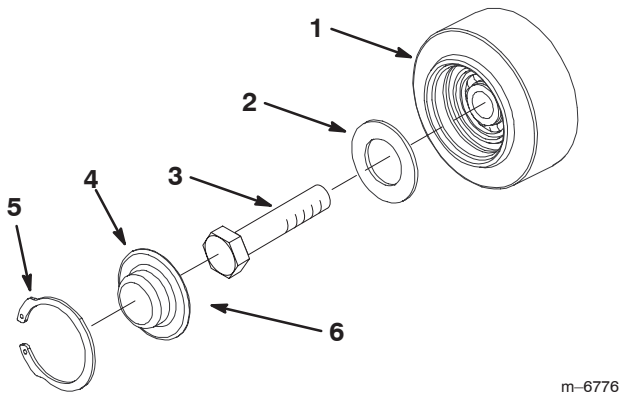

Figure 48

- | | |
|---------------|-----------------------------|
| 1. Road wheel | 4. Road wheel cap |
| 2. Gasket | 5. Snap ring |
| 3. Bolt | 6. Add grease under the cap |

4. Check the grease under the cap and around the gasket (Fig. 48). If it is dirty, gritty, or depleted, clean out all of the grease, replace the gasket, and add new grease.

5. Ensure that the road wheel turns smoothly on the bearing. If it is frozen, replace the road wheel as described in the *Road Wheel Kit Installation Instructions* or contact your Authorized Service Dealer for repair.
6. Place the greased road wheel cap over the bolt head (Fig. 48).
7. Secure the road wheel cap with the snap ring (Fig. 48).
8. Repeat steps 3 through 7 for the other road wheels.
9. Install each track guide to the traction unit frame using the fasteners you removed previously. Torque the bolts to 67 to 83 ft-lb (91 to 112 N·m).
10. Install the tracks; refer to Replacing the Tracks, page 28.

Servicing the Spark Plugs

Check the spark plug after every 100 operating hours. Ensure that the air gap between the center and side electrodes is correct before installing the spark plug. Use a spark plug wrench for removing and installing the spark plug and a gapping tool/feeler gauge to check and adjust the air gap.

Install a new spark plug every 300 operating hours.

Type: NGK BPR6ES, Denso W20EPR-U, or equivalent.
Air Gap: 0.030 inch (0.76 mm)

Removing the Spark Plug

1. Lower the loader arm, stop the engine, and remove the key.
2. Open the hood; refer to Opening the Hood, page 23.
3. Pull the wire off of the spark plug (Fig. 49).

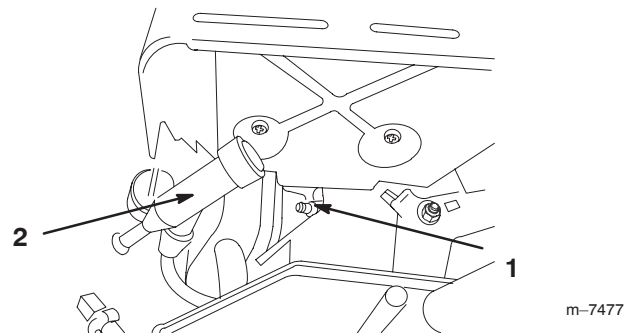

Figure 49

- | | |
|------------------------------|---------------|
| 1. Spark plug wire (removed) | 2. Spark plug |
|------------------------------|---------------|

4. Clean around the spark plug.
5. Remove the spark plug and metal washer.

Note: There is a hole in the front panel through which you can gain access to the spark plug with a socket (Fig. 50).

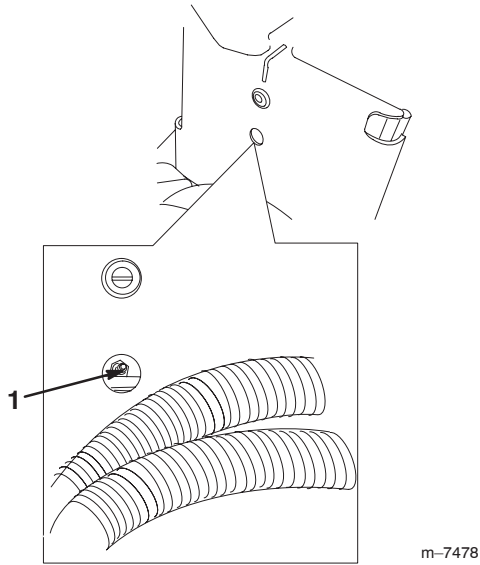

Figure 50

1. Spark plug

Checking the Spark Plug

1. Look at the center of the spark plug (Fig. 51).

If you see light brown or gray on the insulator, the engine is operating properly. A black coating on the insulator usually means the air cleaner is dirty.

Important Never clean the spark plug. Always replace the spark plug when it has a black coating, worn electrode, an oily film, or cracks.

2. Check the gap between the center and side electrodes (Fig. 51).
3. Bend the side electrode (Fig. 51) if the gap is not correct.

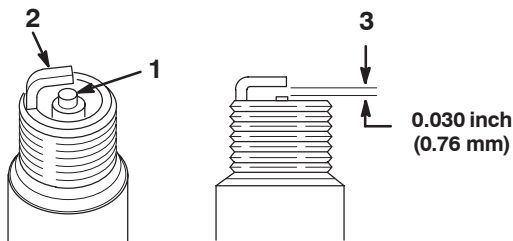

Figure 51

1. Center electrode insulator
2. Side electrode
3. Air gap (not to scale)

Installing the Spark Plug

1. Thread the spark plug into the spark plug hole.
2. Tighten the spark plug until it compresses the metal washer and then seat it as follows:
 - If you are installing a used spark plug, tighten it another 1/8 to 1/4 turn.
 - If you are installing a new spark plug, tighten it another 1/2 turn.

Important A loose spark plug can overheat and damage the engine. Overtightening the spark plug can damage the threads in the cylinder heads.

3. Push the wire onto the spark plug (Fig. 49).
4. Close the hood.

Greasing the Traction Unit

Grease all pivot joints every 8 operating hours and immediately after every washing.

Grease Type: General-purpose grease.

1. Lower the loader arm and stop the engine. Remove the key.
2. Clean the grease fittings with a rag.
3. Connect a grease gun to each fitting (Fig 52 through 59).
4. Pump grease into the fittings until grease begins to ooze out of the bearings (approximately 3 pumps).
5. Wipe up any excess grease.

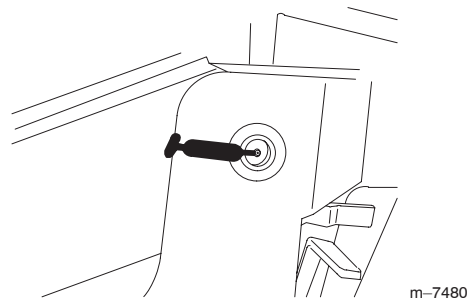
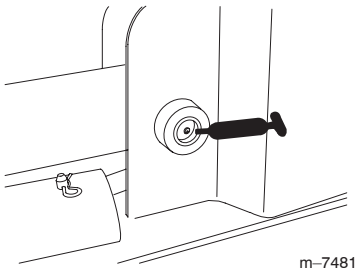
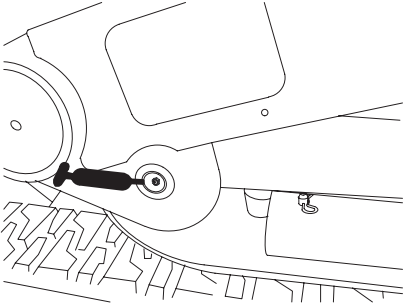

Figure 52



m-7481

Figure 53



m-7482

Figure 54

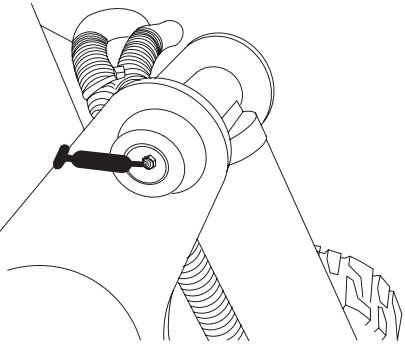

m-7483

Figure 55

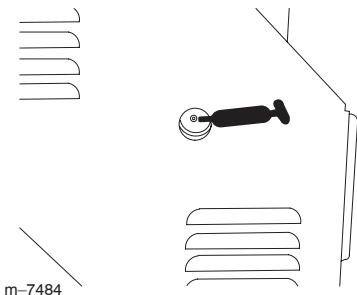

m-7484

Figure 56

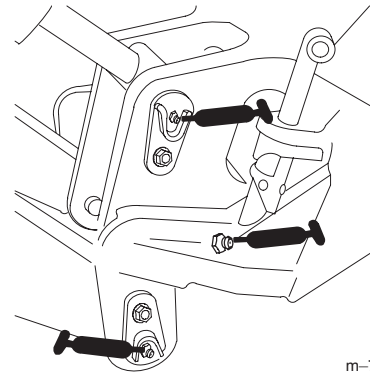

m-7485

Figure 57

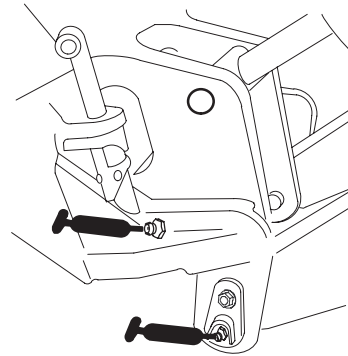

m-7486

Figure 58

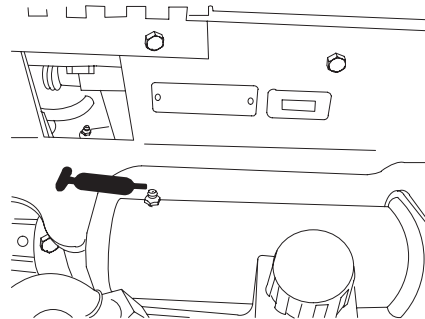

m-7487

Figure 59

Draining the Fuel Tank



Danger



In certain conditions, gasoline is extremely flammable and highly explosive. A fire or explosion from gasoline can burn you and others and can damage property.

- Drain gasoline from the fuel tank when the engine is cold. Do this outdoors in an open area. Wipe up any gasoline that spills.
- Never smoke when draining gasoline, and stay away from an open flame or where a spark may ignite the gasoline fumes.

1. Lower the loader arm, stop the engine, and remove the key.
2. Syphon the gasoline from the tank using a pump type syphon.

Servicing the Hydraulic System

Replacing the Hydraulic Filter

Change the hydraulic filter:

- After the first 8 operating hours.
 - After every 200 operating hours.
1. Position traction unit on a level surface.
 2. Lower the loader arm, stop the engine, and remove the key.
 3. Open the hood; refer to Opening the Hood, page 23.
- Important** Do not substitute an automotive oil filter or severe hydraulic system damage may result.
4. Place a drain pan under the filter (Fig. 60).
 5. Remove the old filter (Fig. 60) and wipe the surface of the filter adapter gasket clean.
 6. Apply a thin coat hydraulic fluid to the rubber gasket on the replacement filter.

7. Install the replacement hydraulic filter onto the filter adapter (Fig. 60). Tighten it clockwise until the rubber gasket contacts the filter adapter, then tighten the filter an additional 3/4 turn.

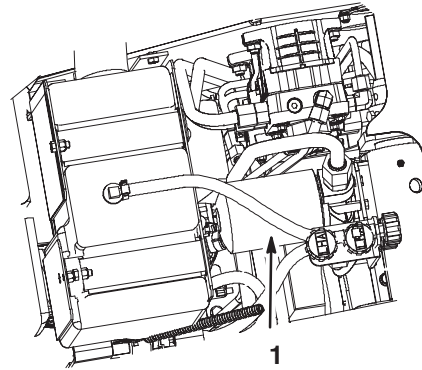

m-7465

Figure 60

1. Hydraulic filter

8. Clean up any spilled fluid.
9. Start the engine and let it run for about two minutes to purge air from the system.
10. Stop the engine and check for leaks.



Warning



Hydraulic fluid escaping under pressure can penetrate skin and cause injury. Fluid injected into the skin must be surgically removed within a few hours by a doctor familiar with this form of injury or gangrene may result.

- Keep your body and hands away from pin hole leaks or nozzles that eject high pressure hydraulic fluid.
- Use cardboard or paper to find hydraulic leaks, never use your hands.

11. Check the fluid level in the hydraulic tank (refer to Checking the Hydraulic Fluid, page 12) and add fluid to raise the level to mark on dipstick. Do not over fill the tank.
12. Close the hood.

Changing the Hydraulic Fluid

Change the hydraulic fluid after every 400 operating hours or yearly.

1. Position the traction unit on a level surface.
2. Raise the loader arm, install the cylinder lock, stop the engine, and remove the key.
3. Open the hood; refer to Opening the Hood, page 23.

4. Allow the traction unit to cool completely.
5. Remove the hydraulic tank cap and dipstick (Fig. 61 and 62).

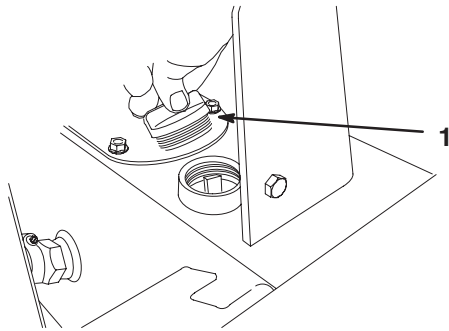

Figure 61

1. Filler neck cap

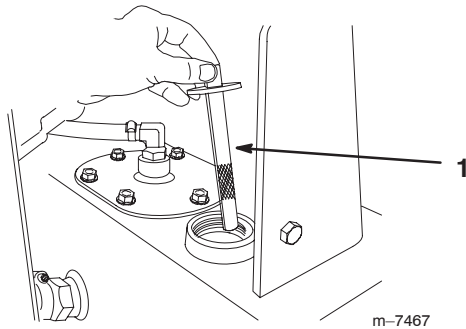

Figure 62

1. Dipstick

6. Place a large drain pan (capable of holding 15 US gallons) under the drain plug on the front of the traction unit (Fig. 63).

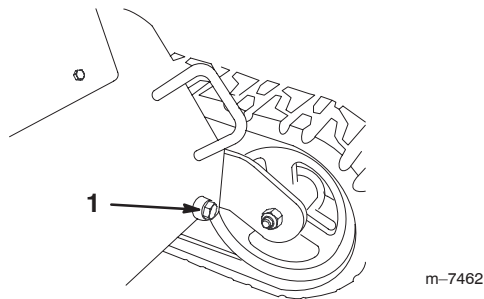

Figure 63

1. Drain Plug



7. Remove the drain plug and allow the oil to drain into the pan (Fig. 63).
8. When finished, install and tighten the drain plug.

Note: Dispose of the used oil at a certified recycling center.



9. Fill the hydraulic tank with approximately 10 US gallons (37.8 l) of 10W-30 or 14W-40 detergent, diesel engine oil (API service CH-4 or higher); refer to Checking Hydraulic Fluid, page 12.
10. Start the engine and let it run for a few minutes.
11. Stop the engine.
12. Check the hydraulic fluid level and top it off if necessary; refer to Checking Hydraulic Fluid, page 12.
13. Close the hood.

Checking the Hydraulic Lines

After every 100 operating hours, check the hydraulic lines and hoses for leaks, loose fittings, kinked lines, loose mounting supports, wear, weather, and chemical deterioration. Replace all moving hydraulic hoses every 1500 hours or 2 years, whichever comes first. Make necessary repairs before operating.

	Warning	
<p>Hydraulic fluid escaping under pressure can penetrate skin and cause injury. Fluid injected into the skin must be surgically removed within a few hours by a doctor familiar with this form of injury or gangrene may result.</p> <ul style="list-style-type: none"> • Keep your body and hands away from pin hole leaks or nozzles that eject high pressure hydraulic fluid. • Use cardboard or paper to find hydraulic leaks, never use your hands. 		

Servicing the Battery

	Warning	
<p>CALIFORNIA</p> <p>Proposition 65 Warning</p> <p>Battery posts, terminals, and related accessories contain lead and lead compounds, chemicals known to the State of California to cause cancer and reproductive harm. Wash hands after handling.</p>		

Important The following procedures apply when servicing a (dry) battery that has replaced the original battery. The original (wet) battery does not require service.

Check the electrolyte level in the battery every 100 hours. Always keep the battery clean and fully charged. Use a paper towel to clean the battery case. If the battery terminals are corroded, clean them with a solution of four parts water and one part baking soda. Apply a light coating of grease to the battery terminals to reduce corrosion.

Voltage: 12 v, 450 Cold Cranking Amps

Checking the Electrolyte Level

1. Open covers to see into the cells. The electrolyte must be up to the lower part of the tube (Fig. 64).

Important Do not allow the electrolyte to get below the plates. (Fig. 64).

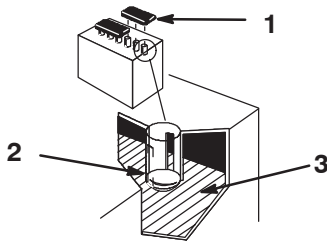

Figure 64

1. Filler caps
2. Lower part of tube
3. Plates

2. If the electrolyte is low, add the required amount of distilled water; refer to Adding Water to the Battery, below.

Adding Water to the Battery

The best time to add distilled water to the battery is just before you operate the traction unit. This lets the water mix thoroughly with the electrolyte solution.

1. Clean the top of the battery with a paper towel.
2. Lift off the filler caps (Fig. 64).
3. Slowly pour distilled water into each battery cell until the level is up to the lower part of the tube (Fig. 64).

Important Do not overfill the battery because electrolyte (sulfuric acid) can cause severe corrosion and damage to the chassis.

4. Press the filler caps onto the battery.

Charging the Battery

Important Always keep the battery fully charged (1.260 specific gravity). This is especially important to prevent battery damage when the temperature is below 32°F (0°C).

1. Check the electrolyte level; refer to Checking Electrolyte Level, page 34.
2. Remove the filler caps from the battery and connect a battery charger to the battery posts (Fig. 2). Charge the battery at a rate of 6 to 10 amperes for a minimum of 1 hour (12 volts).
3. Install the filler caps after the battery is fully charged.

Warning

Charging the battery produces gasses that can explode.

Never smoke near the battery and keep sparks and flames away from battery.

Replacing the Fuses

There are 4 fuses in the electrical system. They are located inside the rear access cover (Fig. 65).

Start Circuit	30 amp.
Charge Circuit	25 amp.
Interlock Circuit	10 amp.
Headlight (optional)	10 amp.

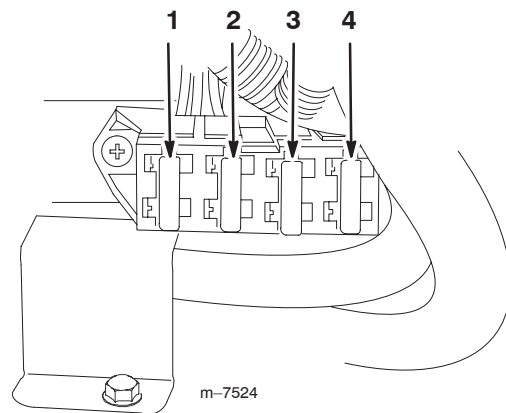

Figure 65

1. Start circuit
2. Charge circuit
3. Headlight
4. Interlock circuit

Storage

1. Lower the loader arm, set the loader valve lock, stop the engine, and remove the key.
2. Remove dirt and grime from the external parts of the entire traction unit, especially the engine. Clean dirt and chaff from the outside of the engine's cylinder head fins and blower housing.

Important You can wash the traction unit with mild detergent and water. Do not pressure wash the traction unit. Avoid excessive use of water, especially near the control panel, engine, hydraulic pumps, and motors.

3. Service the air cleaner; refer to Servicing the Air Cleaner, page 25.
4. Grease the traction unit; refer to Greasing the Traction Unit, page 30.
5. Change the crankcase oil; refer to Servicing the Engine Oil, page 26.
6. Remove the spark plug and check its condition; refer to Servicing the Spark Plug, page 29.
7. With the spark plug removed from the engine, pour two tablespoons of engine oil into the spark plug hole.
8. Place a rag over the spark plug hole to catch any oil spray, then use the starter to crank the engine and distribute the oil inside the cylinder.
9. Install the spark plug, but do not install the wire on it.
10. Charge the battery; refer to Servicing the Battery, page 33.
11. For storage over 30 days, prepare the traction unit as follows.
 - A. Add a petroleum based stabilizer/conditioner to fuel in the tank. Follow mixing instructions from stabilizer manufacturer. (1 oz. per US gallon). **Do not use an alcohol based stabilizer (ethanol or methanol).**

Note: A fuel stabilizer/conditioner is most effective when mixed with fresh gasoline and used at all times.

- B. Run the engine to distribute conditioned fuel through the fuel system (5 minutes).
- C. Stop the engine, allow it to cool and drain the fuel tank using a pump type syphon.
- D. Restart the engine and run it until it stops.
- E. Choke the engine.
- F. Start and run the engine until it will not start again.
- G. Dispose of fuel properly. Recycle as per local codes.

Important Do not store stabilizer/conditioned gasoline over 90 days.

12. Check and adjust the track tension; refer to Adjusting the Track Tension, page 27.
13. Check and tighten all bolts, nuts, and screws. Repair or replace any part that is damaged or defective.
14. Paint all scratched or bare metal surfaces. Paint is available from your Authorized Service Dealer.
15. Store the traction unit in a clean, dry garage or storage area. Remove the key from the ignition switch and keep it in a memorable place.
16. Cover the traction unit to protect it and keep it clean.

Troubleshooting

Problem	Possible Causes	Corrective Action
Starter does not crank	<ol style="list-style-type: none"> 1. The battery is dead. 2. Electrical connections are corroded or loose. 3. A relay or switch is damaged. 	<ol style="list-style-type: none"> 1. Charge the battery. 2. Check the electrical connections for good contact. 3. Contact an Authorized Service Dealer.
Engine will not start, starts hard, or fails to keep running.	<ol style="list-style-type: none"> 1. The fuel tank is empty. 2. The choke is not on. 3. The manual fuel lever is in the Off position. 4. The air cleaner is dirty. 5. The spark plug wire is loose or disconnected. 6. The spark plug is pitted, fouled, or the gap is incorrect. 7. Dirt, water, or stale fuel is in fuel system. 	<ol style="list-style-type: none"> 1. Fill the fuel tank with gasoline. 2. Move the choke lever fully forward. 3. Move the fuel lever to the On position. 4. Clean the air cleaner. 5. Install the wire on the spark plug. 6. Install a new, correctly gapped spark plug. 7. Contact an Authorized Service Dealer.
Engine loses power.	<ol style="list-style-type: none"> 1. Engine load is excessive. 2. The air cleaner is dirty. 3. The oil level in crankcase is low. 4. The cooling fins and air passages around engine are plugged. 5. The spark plug is pitted, fouled, or the gap is incorrect. 6. Dirt, water, or stale fuel is in fuel system. 	<ol style="list-style-type: none"> 1. Reduce ground speed. 2. Clean the air cleaner. 3. Add oil to the crankcase. 4. Remove debris from cooling fins and air passages. 5. Install a new, correctly gapped spark plug. 6. Contact an Authorized Service Dealer.
Engine overheats.	<ol style="list-style-type: none"> 1. The engine load is excessive. 2. The oil level in the crankcase is low. 3. The cooling fins and air passages around engine are plugged. 	<ol style="list-style-type: none"> 1. Reduce ground speed. 2. Add oil to the crankcase. 3. Remove debris from cooling fins and air passages.
Abnormal vibration.	<ol style="list-style-type: none"> 1. The engine mounting bolts are loose. 	<ol style="list-style-type: none"> 1. Tighten the engine mounting bolts.
Traction unit does not drive.	<ol style="list-style-type: none"> 1. The parking brake is on. 2. The hydraulic fluid level low. 3. The tow valves are open. 4. The hydraulic system is damaged. 	<ol style="list-style-type: none"> 1. Release the parking brake. 2. Add hydraulic fluid. 3. Close the tow valves. 4. Contact an Authorized Service Dealer.

Schematics

P/N 88-9830

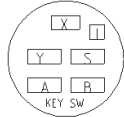

OFF = no connections
 ON = B/A and XY
 START = B/S

Ignition switch terminal locations
 viewed from back

WIRE COLOR CODES

⊖BK-⊖	BLACK	⊖PK-⊖	PINK
⊖BN-⊖	BROWN	⊖R-⊖	RED
⊖BU-⊖	BLUE	⊖T-⊖	TAN
⊖GN-⊖	GREEN	⊖VIO-⊖	VIOLET
⊖GY-⊖	GREY	⊖W-⊖	WHITE
⊖OR-⊖	ORANGE	⊖Y-⊖	YELLOW
⊖BK/Y-⊖	BLACK/YELLOW	⊖W/BU-⊖	WHITE/BLUE

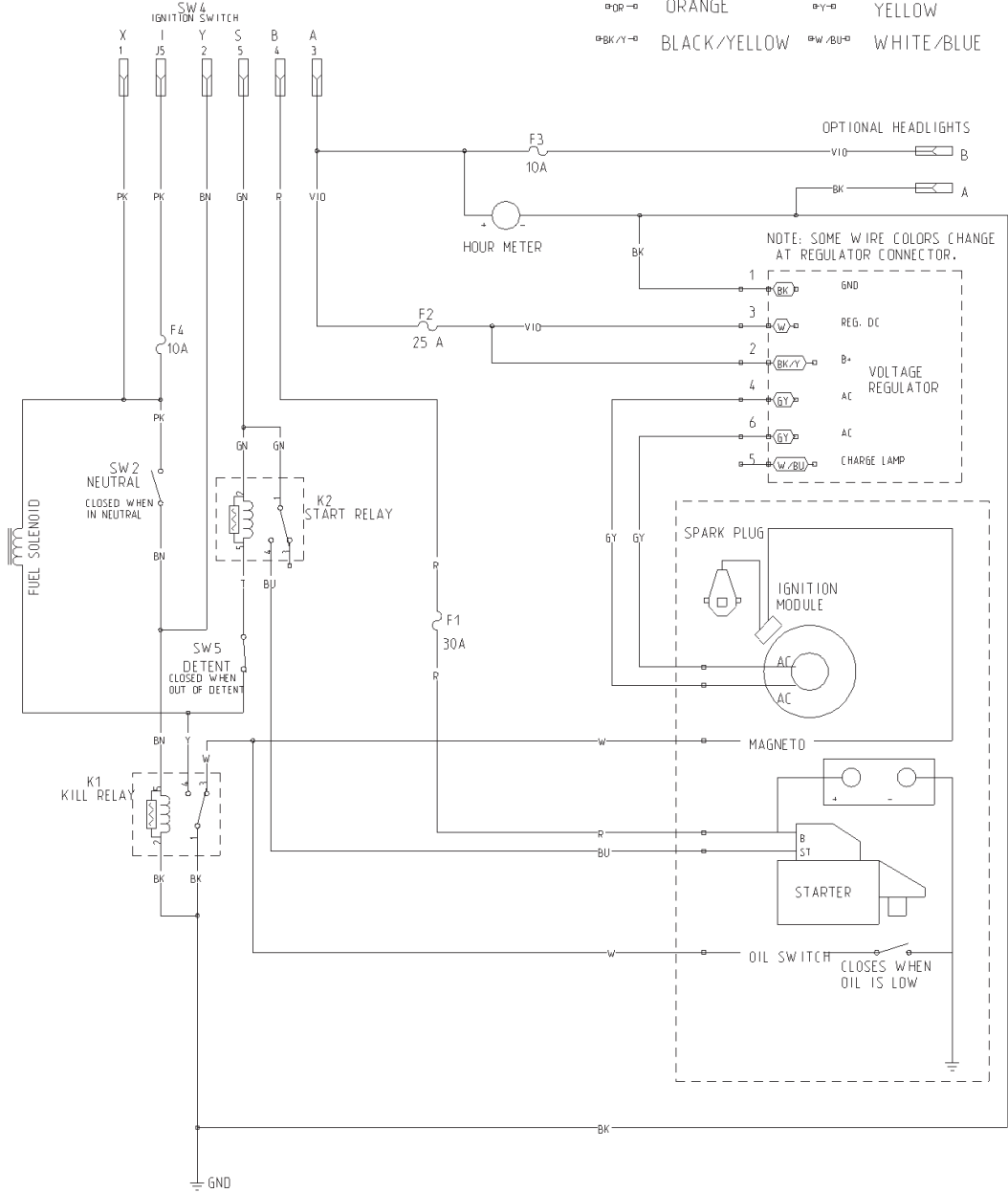

Electrical Schematic

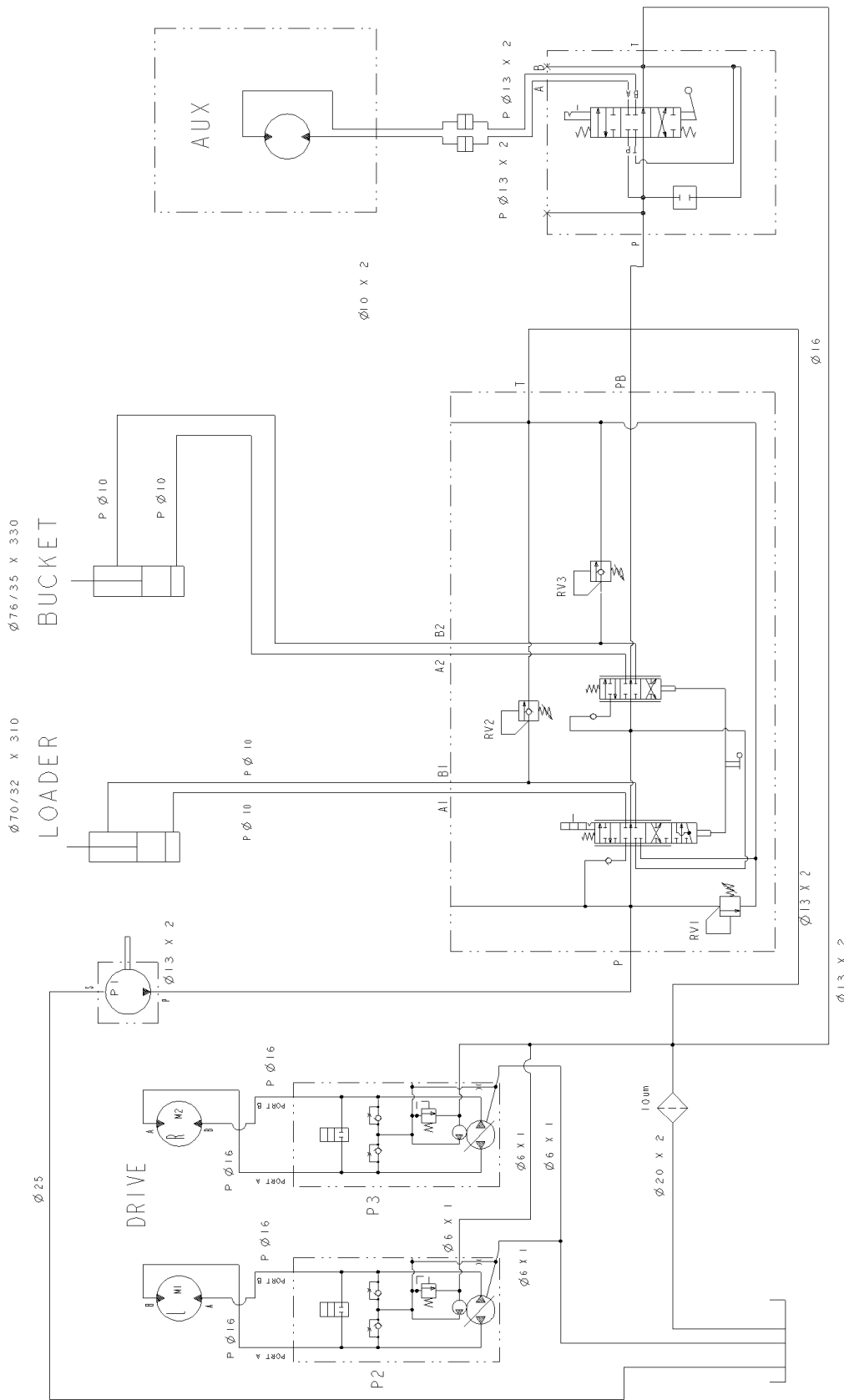

Hydraulic Schematic

DISPLACEMENT AND PRESSURE CHART						
COMPONENT	DISPLACEMENT	PRESSURE		FLOWRATE*		
		PSI	BARS	GPM	LPM	
COMPONENT	CU IN/REV	CU CM/REV	PSI	BARS	GPM	LPM
P1	.44	7.286	3625	250	6.8	25.7
P2, P3	.61	10	2320	160	9.6	36.4
M1, M2	24.7	404	-----	-----	-----	-----
RV1	-----	2540	175	-----	-----	-----
RV2, RV3	-----	2030	140	-----	-----	-----

* FLOWRATE IS THEORETICAL. IT IS CALCULATED USING ENGINE SPEED OF 3600 RPM. IT DOES NOT ACCOUNT FOR COMPONENT EFFICIENCIES.



Evaporative Emission Control Warranty Statement
California Evaporative Emission Control Warranty Statement
Your Warranty Rights and Obligations

Introduction

The California Air Resources Board and The Toro® Company are pleased to explain the evaporative emission control system's warranty on your 2006 model year equipment. In California, new equipment that use small off-road engines must be designed, built, and equipped to meet the State's stringent anti-smog standards. The Toro Company must warrant the evaporative emission control system on your equipment for two years provided there has been no abuse, neglect or improper maintenance of your equipment. Your evaporative emission control system may include parts such as: fuel lines, fuel line fittings, and clamps.

Manufacturer's Warranty Coverage:

This evaporative emission control system is warranted for two years. If any evaporative emission-related part on your equipment is defective, the part will be repaired or replaced by The Toro® Company.

Owner's Warranty Responsibilities:

- As the equipment owner, you are responsible for performance of the required maintenance listed in your Operator's Manual. The Toro® Company recommends that you retain all receipts covering maintenance on your equipment, but The Toro® Company cannot deny warranty solely for the lack of receipts.
- As the equipment owner, you should however be aware that The Toro® Company may deny you warranty coverage if your emission warranty parts have failed due to abuse, neglect, or improper maintenance or unapproved modifications.
- You are responsible for presenting your equipment to an Authorized Service Dealer as soon as the problem exists. The warranty repairs should be completed in a reasonable amount of time, not to exceed 30 days. If you have a question regarding your warranty coverage, you should contact The Toro® Company at 1-952-948-4027 or call us toll free at the number listed in your Toro Warranty statement.

Defects Warranty Requirements:

17. The warranty period begins on the date the engine or equipment is delivered to an ultimate purchaser.
18. General Evaporative Emissions Warranty Coverage. The emission warranty parts must be warranted to the ultimate purchaser and any subsequent owner that the evaporative emission control system when installed was
 - A. Designed, built, and equipped so as to conform with all applicable regulations; and
 - B. Free from defects in materials and workmanship that causes the failure of a warranted part for a period of two years.
19. The warranty on evaporative emissions-related parts will be interpreted as follows:
 - A. Any warranted part that is not scheduled for replacement as required maintenance in the written instructions must be warranted for the warranty period of two years. If any such part fails during the period of warranty coverage, it must be repaired or replaced by The Toro® Company. Any such part repaired or replaced under the warranty must be warranted for a time not less than the remaining warranty period.
 - B. Any warranted part that is scheduled only for regular inspection in the written instructions must be warranted for the warranty period of two years. A statement in such written instructions to the effect of "repair or replace as necessary" will not reduce the period of warranty coverage. Any such part repaired or replaced under warranty must be warranted for a time not less than the remaining warranty period.
 - C. Any warranted part that is scheduled for replacement as required maintenance in the written instructions must be warranted for the period of time prior to the first scheduled replacement point for that part. If the part fails prior to the first scheduled replacement, the part must be repaired or replaced by The Toro® Company. Any such part repaired or replaced under warranty must be warranted for a time not less than the remainder of the period prior to the first scheduled replacement point for the part.
 - D. Repair or replacement of any warranted part under the warranty provisions of this article must be performed at no charge to the owner at an Authorized Service Dealer.
 - E. Notwithstanding the provisions of subsection (D) above, warranty services or repairs must be provided at an Authorized Service Dealer.
 - F. The owner must not be charged for diagnostic labor that leads to the determination that a warranted part is in fact defective, provided that such diagnostic work is performed at an Authorized Service Dealer.
 - G. Throughout the evaporative emission control system's two year warranty period, The Toro® Company must maintain a supply of warranted parts sufficient to meet the expected demand for such parts.
 - H. Manufacturer approved replacement parts must be used in the performance of any warranty maintenance or repairs and must be provided without charge to the owner. Such use will not reduce the warranty obligations of The Toro® Company.
 - I. The use of any add-on or modified parts will be grounds for disallowing a warranty claim made in accordance with this article. The Toro® Company will not be liable under this Article to warrant failures of warranted parts caused by the use of an add-on or modified part.
 - J. The Toro® Company shall provide any documents that describe the warranty procedures or policies within five working days of request by the Air Resources Board.

Emission Warranty Parts List:

The following list includes the parts covered under this warranty:

- Fuel Lines
- Fuel Line Fittings
- Clamps



The Toro Dingo® Product Line Warranty

A One-Year Limited Warranty

Conditions and Products Covered

The Toro Company and its affiliate, Toro Warranty Company, pursuant to an agreement between them, jointly warrant your Toro Dingo Product ("Product") to be free from defects in materials or workmanship. The following time periods apply from the date the Product is delivered to the original retail purchaser:

Products	Warranty Period
• All traction units and attachments	1 year or 1000 operational hours, whichever occurs first
• All engines	2 years

Where a warrantable condition exists, we will repair the Product at no cost to you including diagnosis, labor, and parts.

Instructions for Obtaining Warranty Service

If you think that your Toro Product contains a defect in materials or workmanship, follow this procedure:

1. Contact any Authorized Dingo Service Dealer to arrange service at their dealership. To locate a dealer convenient to you, access our website at www.Toro.com. U.S. Customers may also call 800-348-2424.
2. Bring the product and your proof of purchase (sales receipt) to the Service Dealer.

If for any reason you are dissatisfied with the Service Dealer's analysis or with the assistance provided, contact us at:

LCB Customer Service Department
Toro Warranty Company
8111 Lyndale Avenue South
Bloomington, MN 55420-1196
888-577-7466 (U.S. customers)
877-484-9255 (Canada customers)

Owner Responsibilities

You must maintain your Toro Product by following the maintenance procedures described in the operator's manual. Such routine maintenance, whether performed by a dealer or by you, is at your expense. Parts scheduled for replacement as required maintenance ("Maintenance Parts"), are warranted for the period of time up to the scheduled replacement time for that part. Failure to perform required maintenance and adjustments can be grounds for disallowing a warranty claim.

Items and Conditions Not Covered

Not all product failures or malfunctions that occur during the warranty period are defects in materials or workmanship. This express warranty does not cover the following:

- Product failures which result from the use of non-Toro replacement parts, or from installation and use of add-on, modified, or unapproved accessories

Countries Other than the United States or Canada

Customers who have purchased Toro products exported from the United States or Canada should contact their Toro Distributor (Dealer) to obtain guarantee policies for your country, province, or state. If for any reason you are dissatisfied with your Distributor's service or have difficulty obtaining guarantee information, contact the Toro importer. If all other remedies fail, you may contact us at Toro Warranty Company.

- Product failures which result from failure to perform required maintenance and/or adjustments
- Product failures which result from operating the Product in an abusive, negligent or reckless manner
- Parts subject to consumption through use unless found to be defective. Examples of parts which are consumed, or used up, during normal Product operation include, but are not limited to, digging teeth, tines, spark plugs, tires, tracks, filters, chains, etc.
- Failures caused by outside influence. Items considered to be outside influence include, but are not limited to, weather, storage practices, contamination, use of unapproved coolants, lubricants, additives, or chemicals, etc.
- Normal "wear and tear" items. Normal "wear and tear" includes, but is not limited to, worn painted surfaces, scratched decals or windows, etc.
- Any component covered by a separate manufacturer's warranty
- Pickup and delivery charges

General Conditions

Repair by an Authorized Toro Service Dealer is your sole remedy under this warranty.

Neither The Toro Company nor Toro Warranty Company is liable for indirect, incidental or consequential damages in connection with the use of the Toro Products covered by this warranty, including any cost or expense of providing substitute equipment or service during reasonable periods of malfunction or non-use pending completion of repairs under this warranty.

Some states do not allow exclusions of incidental or consequential damages, or limitations on how long an implied warranty lasts, so the above exclusions and limitations may not apply to you.

This warranty gives you specific legal rights, and you may also have other rights which vary from state to state.

Except for the Emissions warranty referenced below, if applicable, there is no other express warranty. All implied warranties of merchantability and fitness for use are limited to the duration of this express warranty.

Note to California residents: The Emissions Control System on your Product may be covered by a separate warranty meeting requirements established by the U.S. Environmental Protection Agency (EPA) or the California Air Resources Board (CARB). The hour limitations set forth above do not apply to the Emissions Control System Warranty. Refer to the California Emission Control Warranty Statement printed in you operator's manual or contained in the engine manufacturer's documentation for details.