



Dingo[®] 220 Compact Utility Loader

Model No. 22317 - 260000001 and up.

Parts Catalog

Ordering Replacement Parts

To order replacement parts, please supply the part number, the quantity, and the description of each part desired.

Understanding Reference Numbers

Each Identified part in an illustration has a reference number. The reference number for a part also appears in the parts list, along with other information about the part.

This catalog uses two special reference number formats, one to indicate parts in a service assembly and another to indicate the quantity of a given part in an illustration.

Service Assembly Reference Numbers

Parts in service assemblies have reference numbers in the form a:b. The a represents the reference number of the entire service assembly and the b represents a sequential number unique to each part within the service assembly.

For example, a wheel assembly might be identified by reference number 6, the tire by 6:1, the valve by 6:2, and the wheel by 6:3. When you order the assembly identified by reference number 6, you receive all parts identified by reference numbers 6:1, 6:2, and 6:3. However, you may also order any part individually. Reference numbers of this type appear in illustrations and in part lists.

Reference Numbers Indicating Quantity

In an illustration, if a reference number indicates more than one part, the reference number has the form nX y. The n represents the quantity of the part, the X is the multiplication symbol, and the y represents the reference number.

For example, in an illustration, the reference number 2X 37 means that two of the parts identified by reference number 37 are indicated.

Contents

Description	Page	Description	Page
Frame and Loader Arm Assembly 3	Crankcase Assembly Kohler CH20S 64733 20
Front Wheel Assembly 4	Oil Pan and Lubrication Assembly Kohler CH20S 64733 21
Rear Wheel Assembly 5	Head, Valve, and Breather Assembly Kohler CH20S 64733 22
Hydraulic Motor Assembly No. 99-3052 6	Ignition and Electrical Assembly Kohler CH20S 64733 23
Engine Assembly 7	Blower Housing and Baffle Assembly Kohler CH20S 64733 24
Hydraulic Motor Assembly No. 108-4710 8	Starting System Assembly Kohler CH20S 64733 25
Hydraulic Assembly 9	Fuel System Assembly Kohler CH20S 64733 26
Hydraulic Valve Assembly 10	Engine Control Assembly Kohler CH20S 64733 27
Hydraulic Selector Valve Assembly No. 99-3072 11	Air Intake and Filtration Assembly Kohler CH20S 64733 28
Auxiliary Hydraulic Valve Assembly No. 99-3077 12	Exhaust Assembly Kohler CH20S 64733 29
Hydraulic Traction Assembly 13	Attachments and Accessories List 30
Hydraulic Valve Assembly No. 105-6246 15		
Hydraulic Cylinder Assembly 16		
Hydraulic Cylinder Assembly No. 105-7867 17		
Electrical Assembly 18		
Crankshaft Assembly Kohler CH20S 64733 19		

Part Description Abbreviations

Part descriptions in this catalog may include the following abbreviations.

AR. as required	INC. incorporated
ASM. assembly	LH. left hand
BBC. blade brake clutch	NI. nylon insert
CARR. carriage	NPTF. national pipe thread fine
DEG. degrees	PFH. phillips flat head
EXT. external	PPH. phillips pan head
FH. flat head	PPHTF. phillips pan head thread forming
GA. gauge	PRH. phillips round head
HF. hex flange	PTH. phillips truss head
HH. hex head	PTO. power-take-off
HHF. hex head flange	RH. right hand
HHFTF. hex head flange thread forming	ROPS. roll-over-protection-system
HJ. hex jam	SFH. slotted fillister head
HLH. hex lag head	SHH. slotted hex head
HOC. height-of-cut	SHWH. slotted hex washer head
HSBH. hex socket button head	SPH. slotted pan head
HSFH. hex socket flat head	SQH. square head
HSH. hex socket head	SRH. slotted round head
HWH. hex washer head	STD. standard
HWHTF. hex washer head thread forming	TAP. self tapping
HYD. hydraulic	TTH. torx truss head

Footnotes

- ❶ Not illustrated
- ❷ Not serviced separately
- ❸ Obtain from your local Kohler dealer

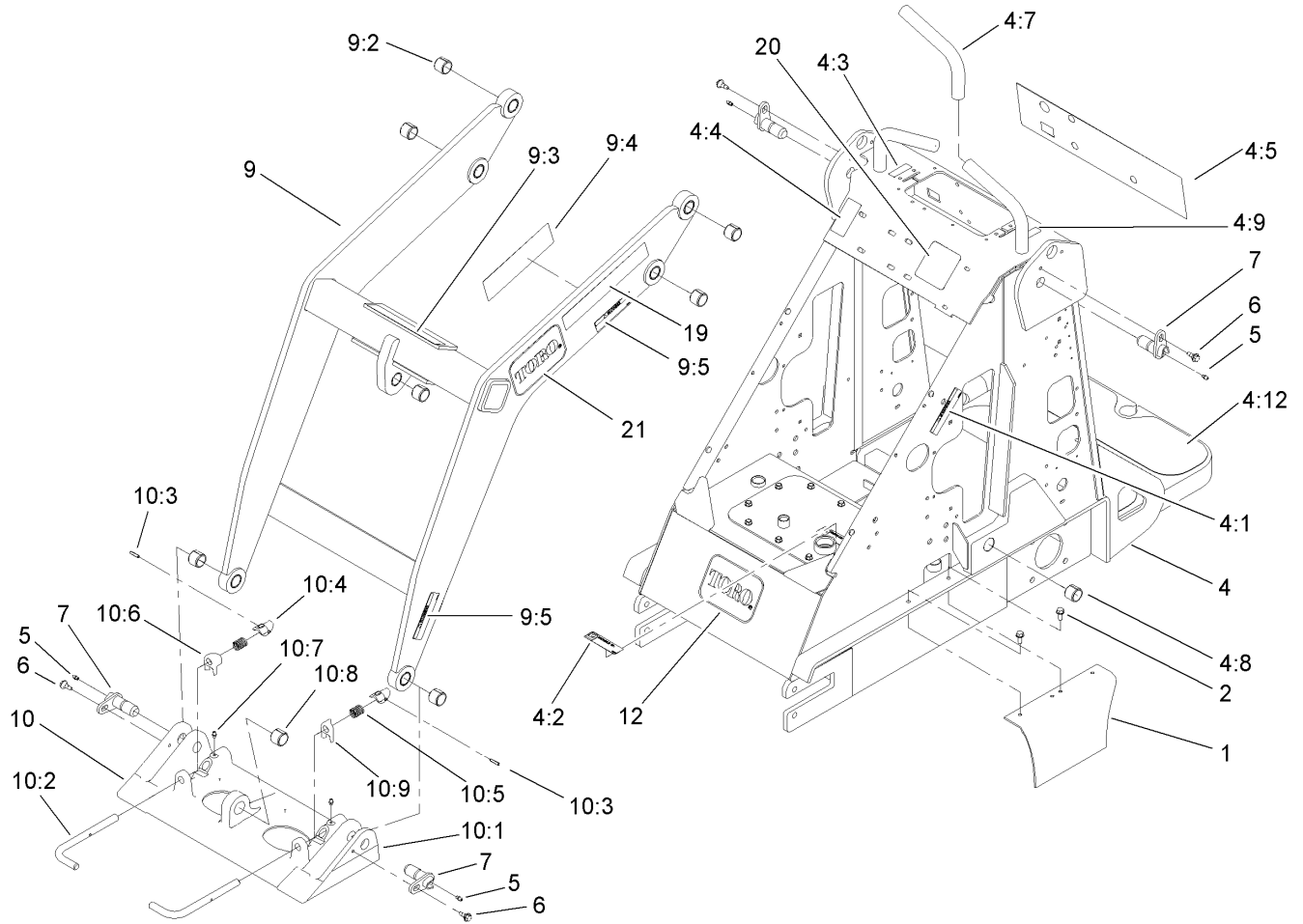

Frame and Loader Arm Assembly

Ref	Part No.	Qty.	Description
1	98-4669-01	2	Cover-Chain
2	32144-70	4	Screw-HH
4	108-9700	1	Frame ASM
4:1	100-6141	2	Decal-Pinch
4:2	105-8432	1	Decal-Oil, HYD
4:3	94-2551	1	Decal-Choke
4:4	98-4677	1	Decal-Power, Auxiliary
4:5	108-9732	1	Decal-Panel, Control
4:7	98-4845	2	Grip-Cushion
4:8	98-4871	2	Bushing-Tension
4:9	98-8219	1	Decal-Throttle
4:12	98-9947	2	Tread-Foot
5	302-5	4	Fitting-Grease
6	99-5105	4	Bolt-Shoulder
7	99-1414	4	Pin-Pivot
9	106-8155	1	Loader ASM
9:2	98-4871	7	Bushing-Tension
9:3	98-4682	1	Decal-Caution
9:4	98-9051	1	Decal-Danger
9:5	100-6141	4	Decal-Pinch
10	105-8364	1	Quick Attach ASM
10:1	105-0245-03	1	Mount-Attach, Quick
10:2	105-8367	2	Pin-Locking
10:3	3285-1	2	Pin-Grooved

Ref	Part No.	Qty.	Description
10:4	105-0246	2	Cam
10:5	98-4694	2	Spring-Compression
10:6	104-5909	1	Stop-RH
10:7	302-5	2	Fitting-Grease
10:8	98-4871	1	Bushing-Tension
10:9	104-5903	1	Stop-LH
12	62-5550	1	Decal
19	105-8426	2	Decal
20	108-9716	1	Decal-Selector, Speed
21	93-7340	2	Decal

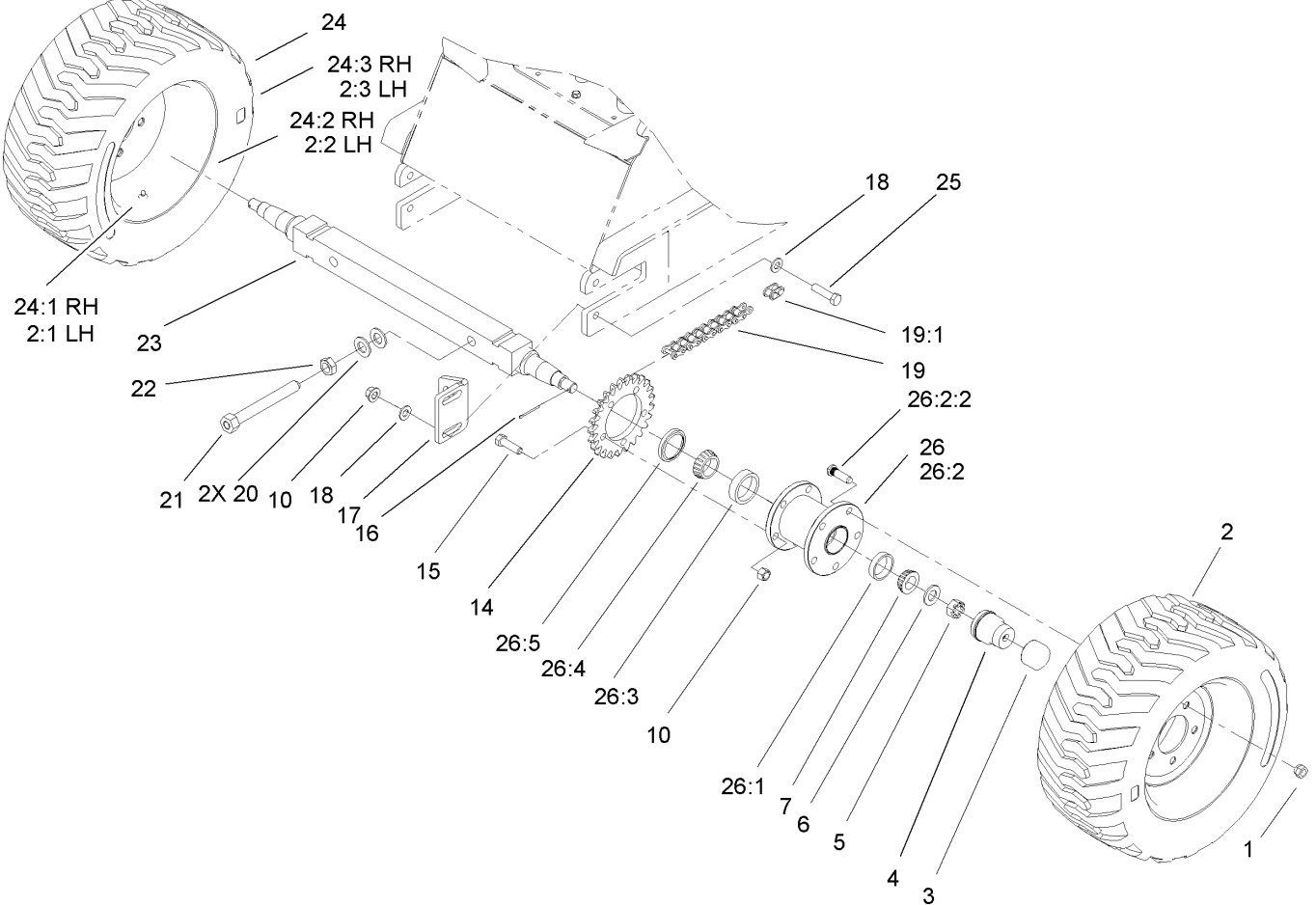

Front Wheel Assembly

Ref	Part No.	Qty.	Description
1	242-50	10	Nut-Lug
2	98-2747	1	LH Wheel And Tire ASM
2:1	232-27	1	Stem-Valve
2:2	98-2748	1	Wheel
2:3	98-2749	1	Tire
3	100-3809	2	Cap-Protector, Bearing
4	100-3769	2	Protector-Bearing
5	32136-5	2	Nut-Hex, Slotted
6	3256-28	2	Washer-Flat
7	254-94	2	Bearing-Cone, Tapered
10	3296-23	14	Nut-Lock, NI
14	98-9937	2	Sprocket-25T
15	325-7	10	Screw-HH
16	3272-12	2	Pin-Cotter
17	99-5106-03	2	Bracket-Axle
18	3256-26	8	Washer-Flat
19	98-4906	2	Chain-Roller
19:1	98-9089	1	Link-Connecting
20	3256-28	4	Washer-Flat
21	98-4706	2	Bolt-Tension
22	3217-12	2	Nut-Hex
23	98-4825	1	Axle
24	99-1447	1	RH Wheel And Tire ASM
24:1	232-27	1	Stem-Valve

Ref	Part No.	Qty.	Description
24:2	98-2748	1	Wheel
24:3	98-2749	1	Tire
25	325-8	4	Screw-HH
26		2	Hub-Front
26:1	254-72	1	Bearing-Cup, Tapered
26:2	100-9989	1	Front Hub ASM
26:2:2	10-6830	5	Stud-Type, Drive
26:3	254-107	1	Cup-Bearing, Tapered
26:4	254-106	1	Cone-Bearing, Tapered
26:5	98-4705	1	Seal-Bearing, Wheel

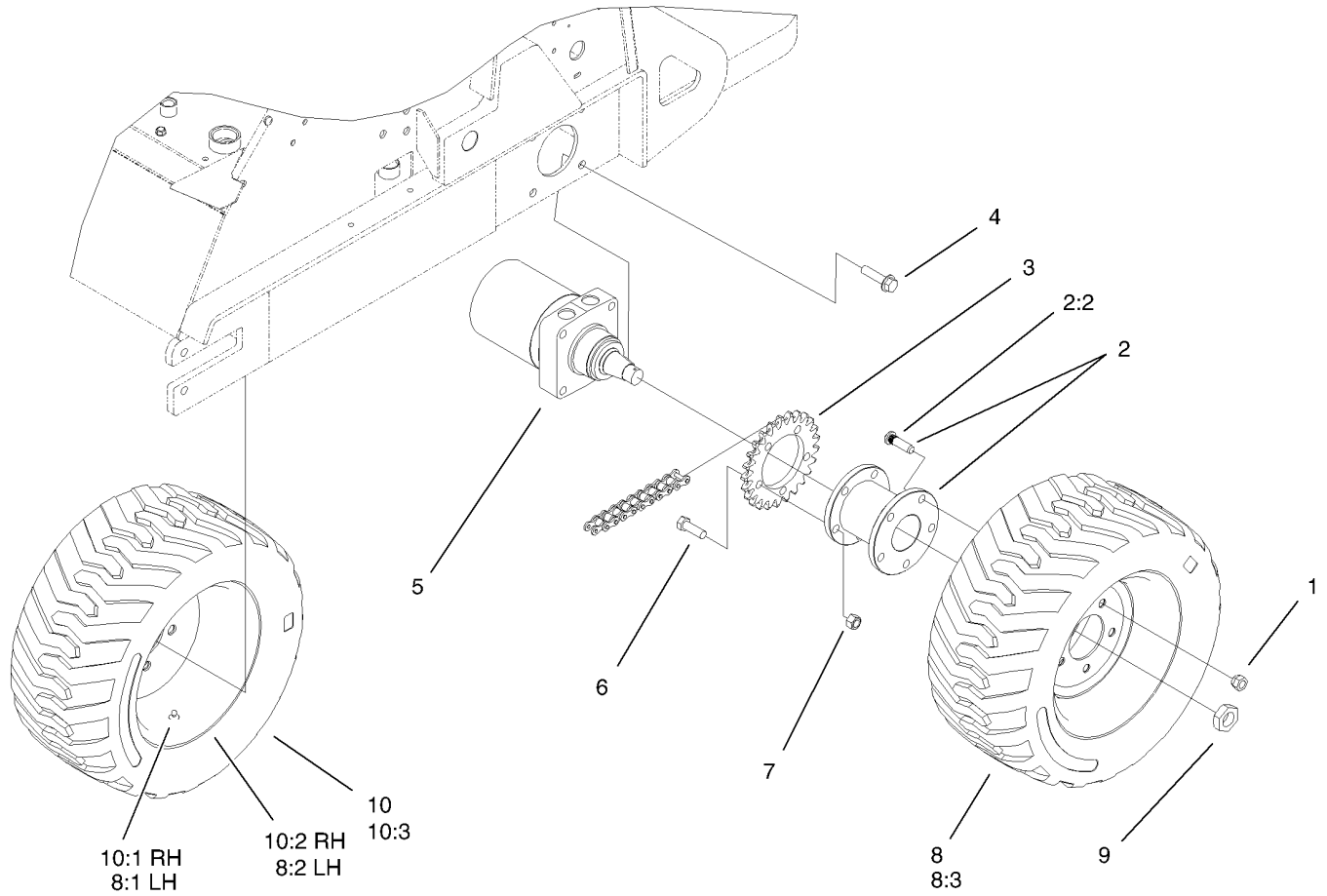

Rear Wheel Assembly

Ref	Part No.	Qty.	Description
1	242-50	10	Nut-Lug
2	100-9990	2	Rear Hub ASM
2:2	10-6830	5	Stud-Type, Drive
3	98-9937	2	Sprocket-25T
4	3234-27	8	Screw-Flange
5	99-3052	2	HYD Motor ASM
6	325-7	10	Screw-HH
7	3296-23	10	Nut-Lock, NI
8	98-2747	1	LH Wheel And Tire ASM
8:1	232-27	1	Stem-Valve
8:2	98-2748	1	Wheel
8:3	98-2749	1	Tire
9	106-8159	2	Nut-Lock
10	99-1447	1	RH Wheel And Tire ASM
10:1	232-27	1	Stem-Valve
10:2	98-2748	1	Wheel
10:3	98-2749	1	Tire

--	--	--	--

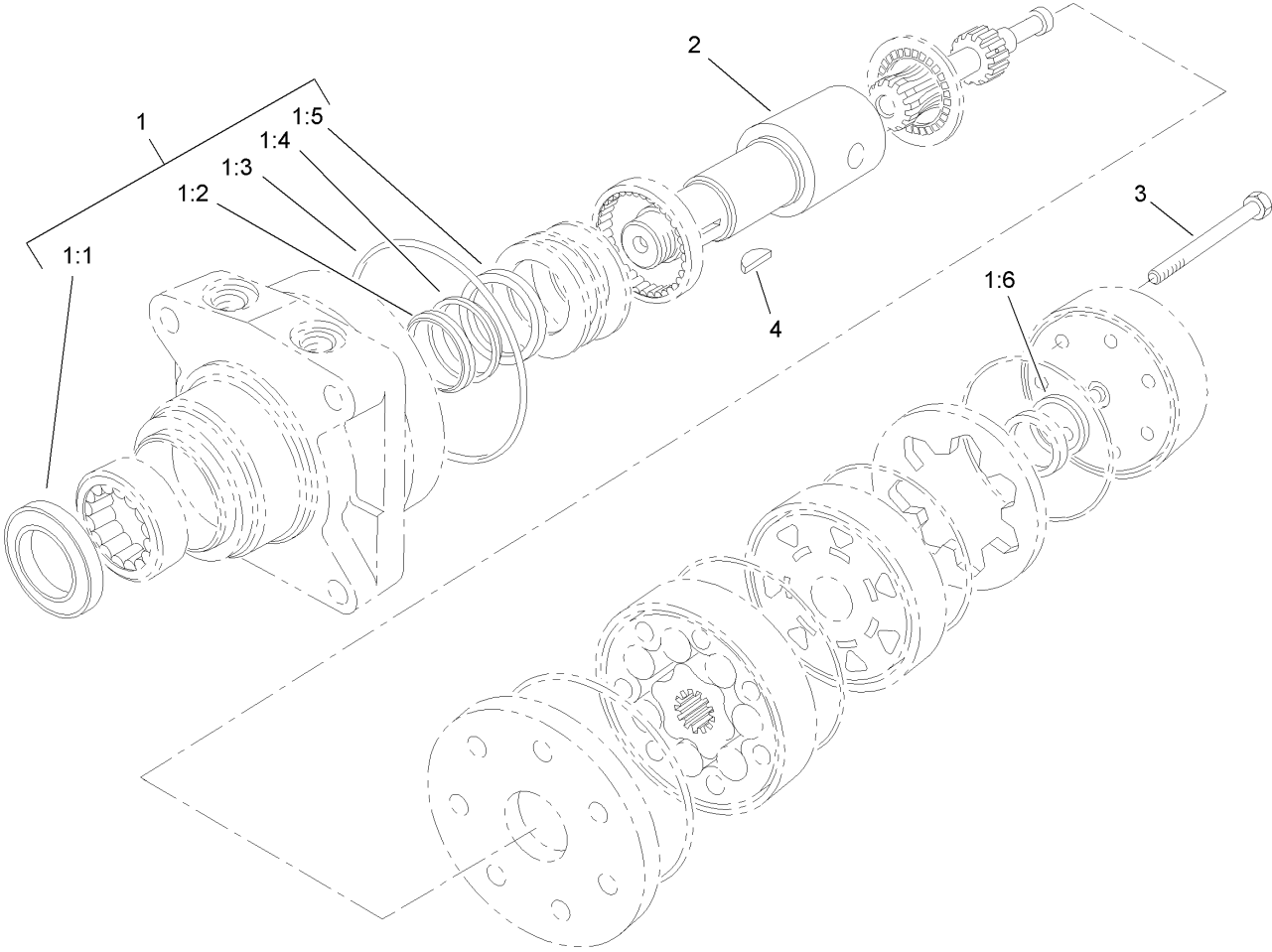

Hydraulic Motor Assembly No. 99-3052

Ref	Part No.	Qty.	Description
1	94-8178	1	Seal Kit
② 1:1		1	Seal-Dirt And Water
② 1:2		1	Washer-Backup
② 1:3		5	Seal-Ring
② 1:4		1	Washer-Backup
② 1:5		1	Seal-Inner
② 1:6		1	Seal-Commutator
2	99-3090	1	Shaft-Coupling
3	99-3091	7	Screw-Cap, HH
4	3257-42	1	Key-Woodruff

--	--	--	--

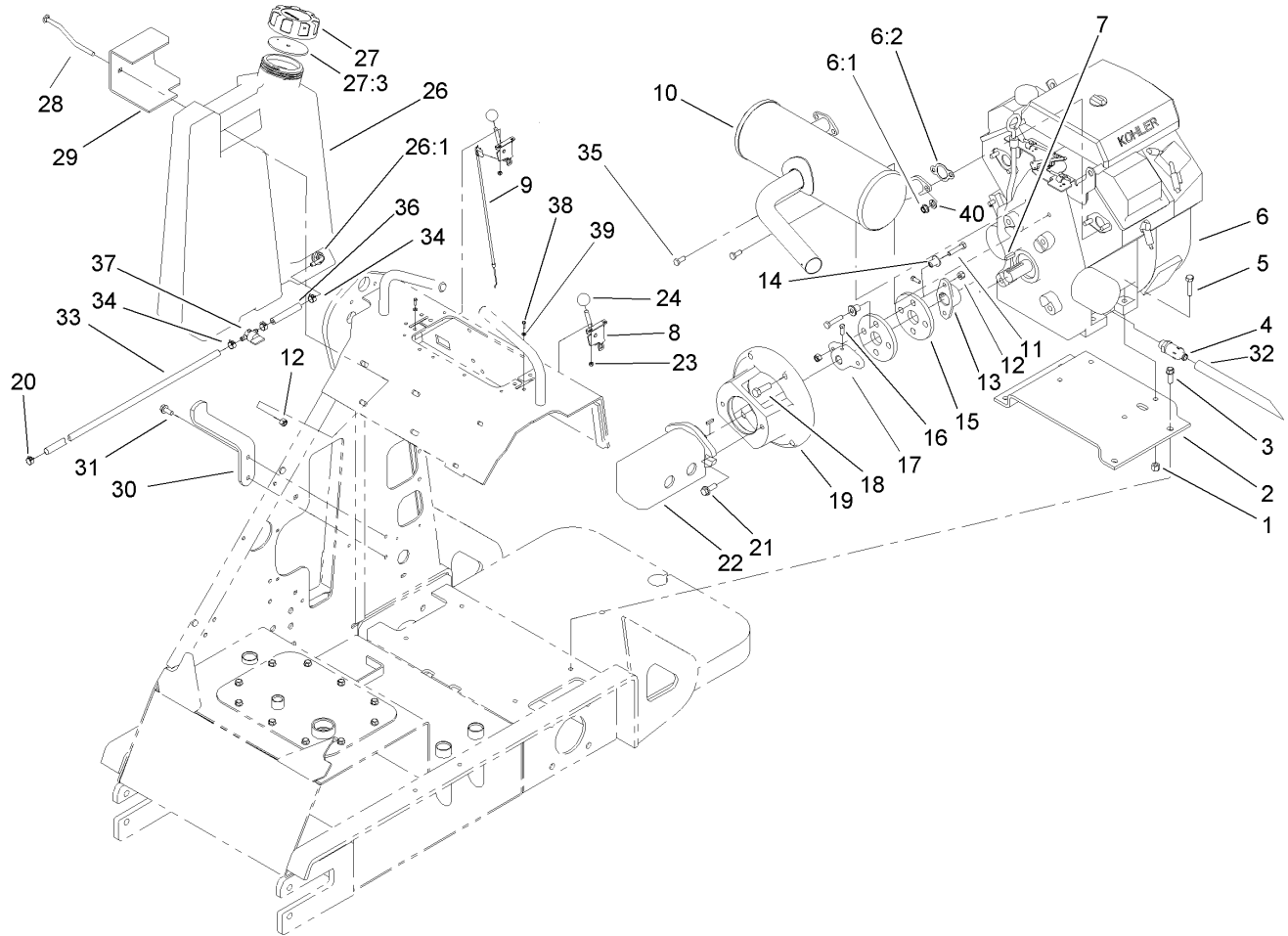

Engine Assembly

Ref	Part No.	Qty.	Description
1	3296-39	4	Nut-Lock, NI
2	98-4666-03	1	Mount-Engine
3	95-1726	4	Screw-Taptite
4	92-6877	1	Valve-Drain, Oil
5	323-9	4	Screw-HH
6		1	Engine-Kohler, Ch20S 64733
6:1	92-6780	4	Nut-HF
6:2	93-0350	2	Gasket-Exhaust
7	10-7070	1	Key-Square
8	108-9730	2	Control Lever ASM
9	108-4718	2	Cable-Control
10	105-8381	1	Muffler
11	322-7	4	Screw-HH
12	3296-29	5	Nut-Lock, NI
13	27-1960	1	Hub-Engine
14	71-4411	4	Spacer
15	44-2230	2	Coupling-Rubber
16	3241-6	4	Screw-SQH
17	98-4701	1	Hub-Pump
18	324-6	4	Screw-HH
19	98-2751-03	1	Mount-Pump
20	2412-98	1	Clamp
21	66-9300	2	Screw-HF
22	108-4710	1	HYD Pump ASM

Ref	Part No.	Qty.	Description
23	32149-7	4	Nut-Keps
24	233-42	2	Knob
26	105-8440	1	RH Fuel Tank ASM
26:1	103-2605	1	Fitting-Fuel, Bulkhead
27	104-7418	1	Cap-Fuel, Gas
27:3	104-7420	1	Gasket-Vented
28	98-4657	1	Bolt-Mount
29	98-4655-03	1	Plate-Mount
30	98-4656-03	1	Mount-Bottom, Tank
31	32144-70	2	Screw-HH
32	98-4667	1	Hose-Drain, Oil
33	109-0273	1	Hose-Fuel
34	92-2379	3	Clamp-Hose
35	33114-020	2	Screw-HH
36	109-0304	1	Hose-Fuel
37	1-603770	1	Valve-Fuel
38	3290-134	4	Screw
39	3256-51	4	Washer-Flat
40	3253-4	4	Washer-Lock

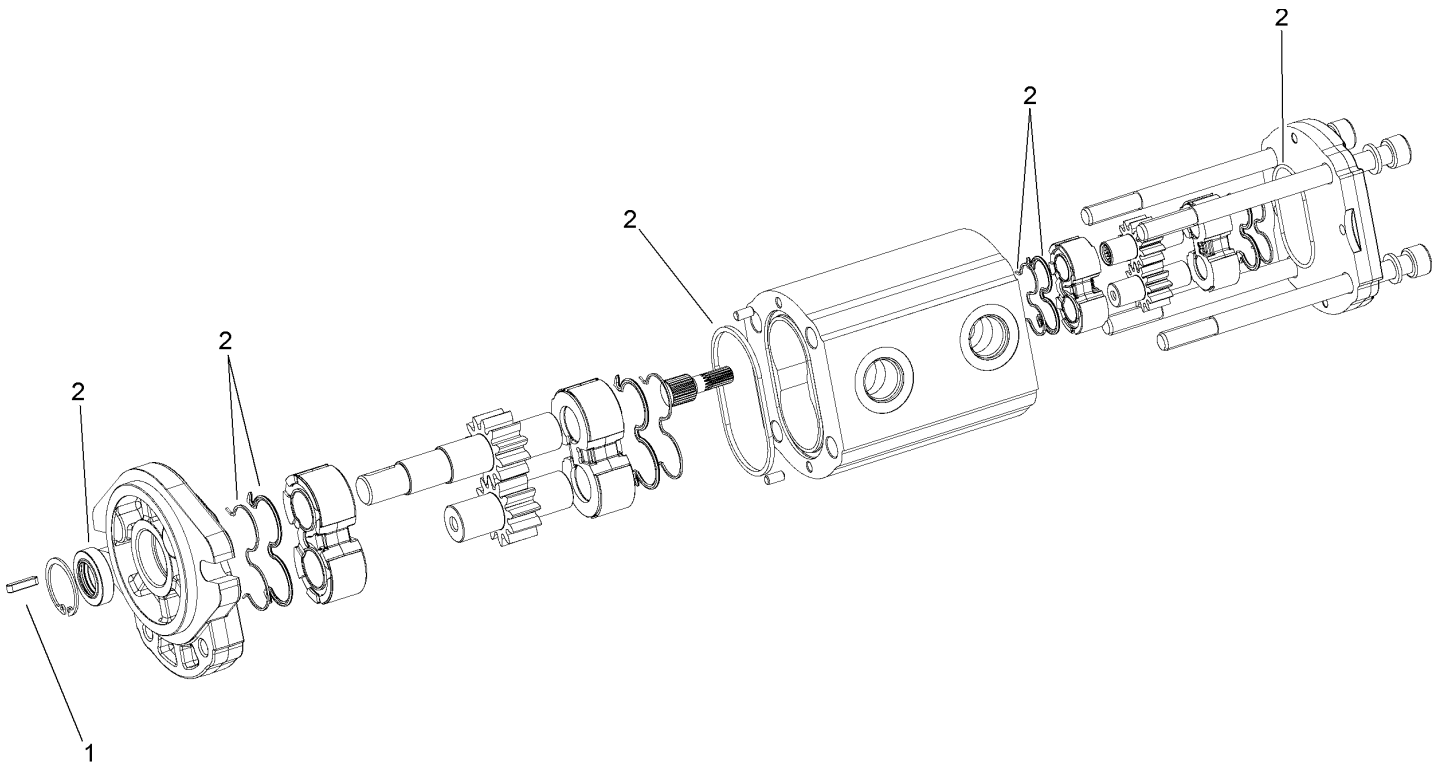

Hydraulic Motor Assembly No. 108-4710

Ref	Part No.	Qty.	Description
1	98-4700	1	Key-Square
2	99-1353	1	Seal Kit

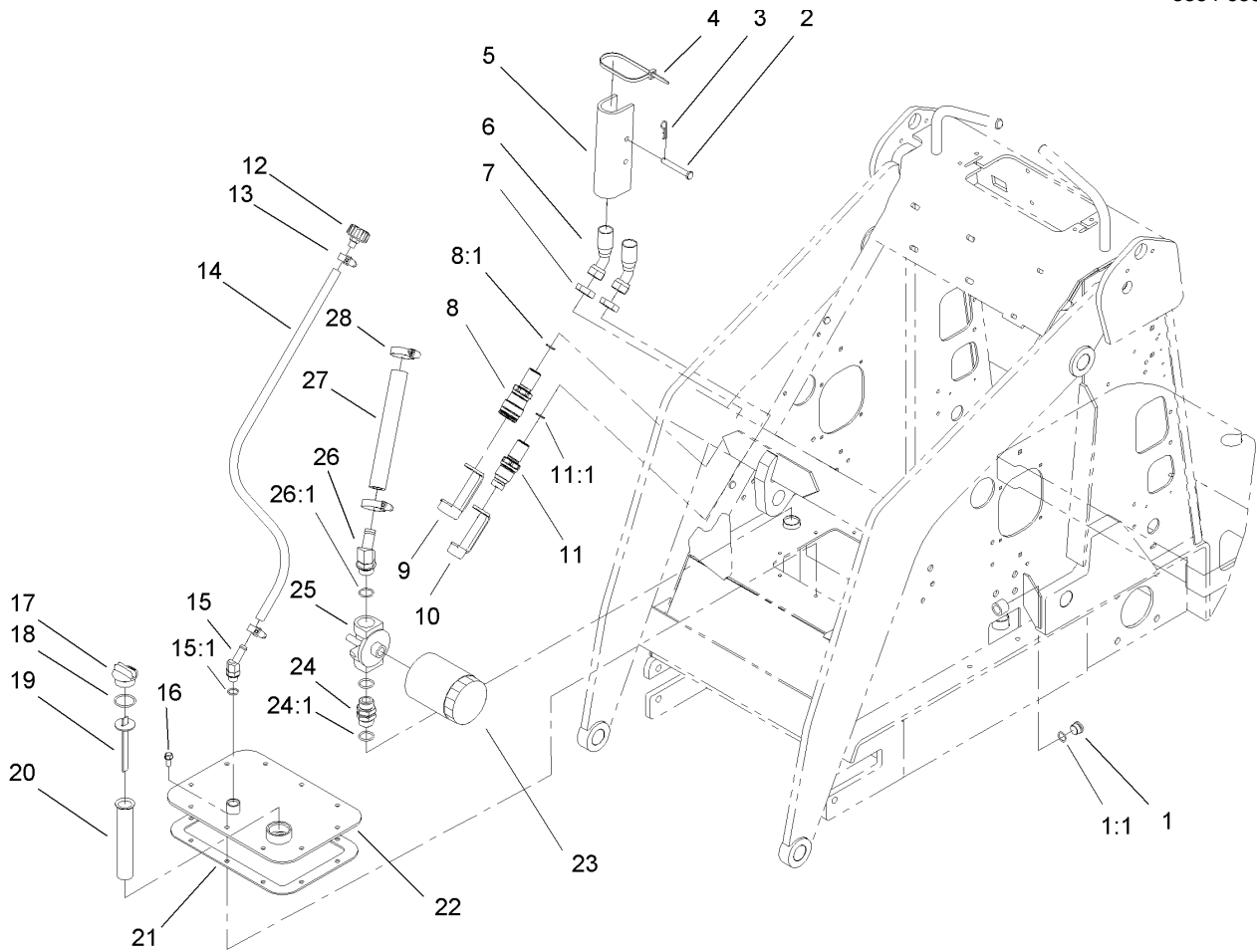

Hydraulic Assembly

Ref	Part No.	Qty.	Description
1	353-988	1	Plug-Hex
1:1	237-79	1	O-Ring
2	283-52	2	Pin-Clevis
3	3290-467	2	Pin-Hair
4	3290-379	9	Tie-Cable
5	98-4675-01	2	Lock-Cylinder
6	100-8817	2	HYD Hose ASM
7	340-74	2	Locknut-Bulkhead
8	105-8394	1	Bulkhead Coupler ASM
8:1	237-65	1	O-Ring
8:2	105-8396	1	Seal Kit
9	100-8816	1	Cap-Dust, Coupler
10	100-8815	1	Cap-Dust, Nipple
11	105-8395	1	Bulkhead Nipple ASM
11:1	237-65	1	O-Ring
11:2	100-6120	1	Seal Kit
12	68-6150	1	Breather
13	2412-36	2	Clamp-Hose
14	98-2708	1	Hose-Vent
15	354-126	1	Fitting-HYD, 45 DEG
15:1	237-79	1	O-Ring
16	98-9940	10	Screw
17	93-7498	1	Plug-Plastic
18	237-123	1	O-Ring

Ref	Part No.	Qty.	Description
19	100-2097	1	Dipstick-Oil
20	61-2790	1	Filter-Screen
21	98-9927	1	Gasket-Cover
22	98-2709	1	Cover
23	54-0110	1	Filter-Oil, Transmission
24	98-9906	1	Fitting-Thread, Straight
24:1	237-81	2	O-Ring
25	92-5821	1	Filter Head ASM
26	354-127	1	Elbow-45 DEG
26:1	237-81	1	O-Ring
27	98-2713	1	Hose-Suction, HYD
28	2412-129	2	Clamp-Hose

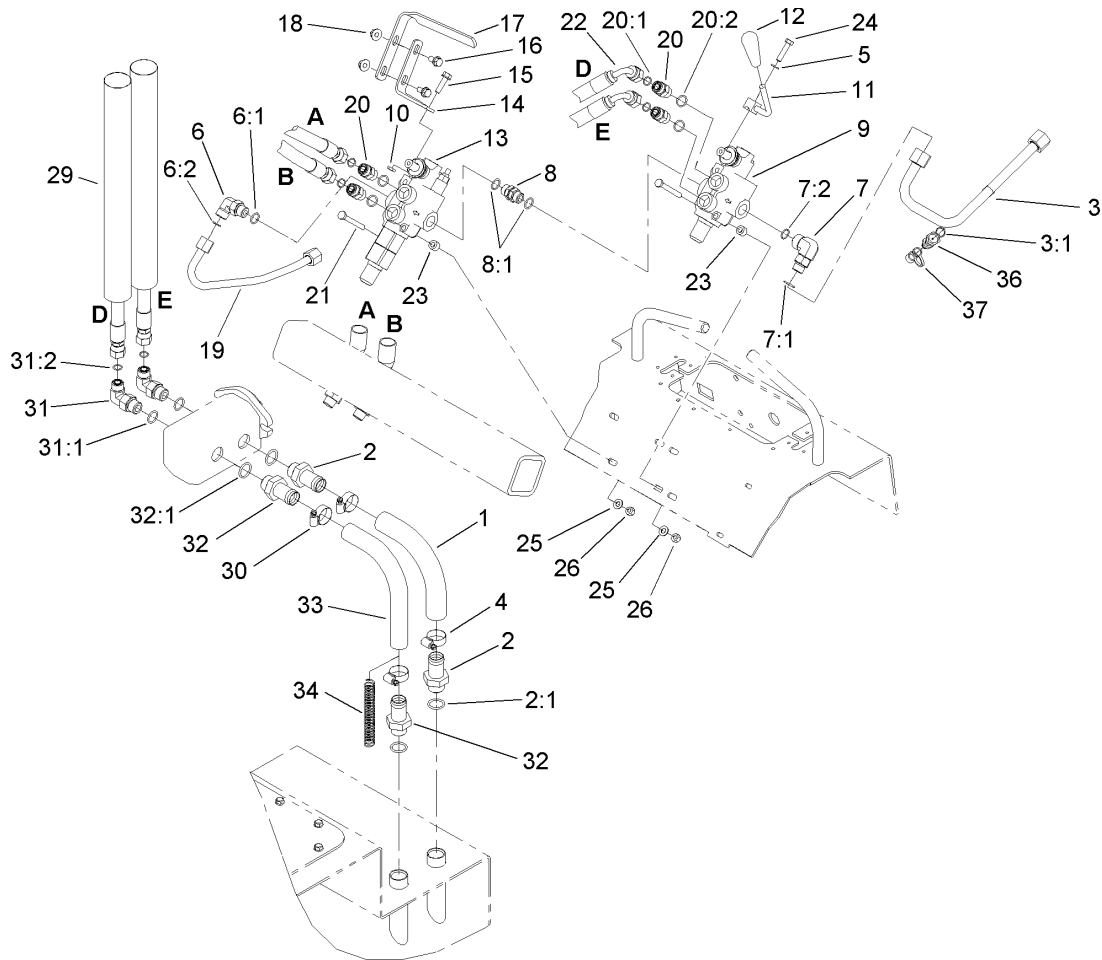

Hydraulic Valve Assembly

Ref	Part No.	Qty.	Description
1	99-3046	1	Hose-Suction, Formed
2	99-3017	2	Fitting
2:1	237-81	1	O-Ring
3	108-4716	1	HYD Tube ASM
3:1	237-22	1	O-Ring
4	2412-111	2	Clamp
5	3253-4	1	Washer-Lock
6	340-98	1	Fitting-HYD, 90 DEG
6:1	237-79	1	O-Ring
6:2	237-30	1	O-Ring
7	340-153	1	Fitting-Elbow, 90 DEG
7:1	237-79	1	O-Ring
7:2	237-151	1	O-Ring
8	95-3209	1	Fitting-Thread, Straight
8:1	237-79	2	O-Ring
9	99-3072	1	Valve-Selector
10	33014-00	1	Nut-Hex
11	108-9709-03	1	Lever-Control
12	98-0152	1	Knob-Tapered
13	99-3077	1	Valve-HYD, Auxiliary
14	99-1376	1	Mount-Control
15	33104-030	1	Screw-HHF
16	3234-5	2	Screw-HHF
17	98-9090	1	Grip-Control

Ref	Part No.	Qty.	Description
18	32128-44	2	Nut
19	105-7879	1	Tube-HYD
20	340-4	4	Fitting-HYD, Straight
20:1	237-30	1	O-Ring
20:2	237-79	1	O-Ring
21	322-13	4	Screw-HH
22	98-4747	2	HYD Hose ASM
23	98-4695	4	Spacer
24	33114-035	1	Screw-HH
25	3256-23	4	Washer-Flat
26	3296-29	4	Nut-Lock, NI
29	100-8818	2	Sleeve-Guard, Hose
30	2412-129	2	Clamp-Hose
31	340-105	2	Fitting-HYD, 90 DEG
31:1	237-80	1	O-Ring
31:2	237-30	1	O-Ring
32	354-73	2	Fitting
32:1	237-81	1	O-Ring
33	98-2713	1	Hose-Suction, HYD
34	99-5349	1	Spring-Compression
36	86-5480	1	Nipple-Test
37	354-79	1	Cap-Dust

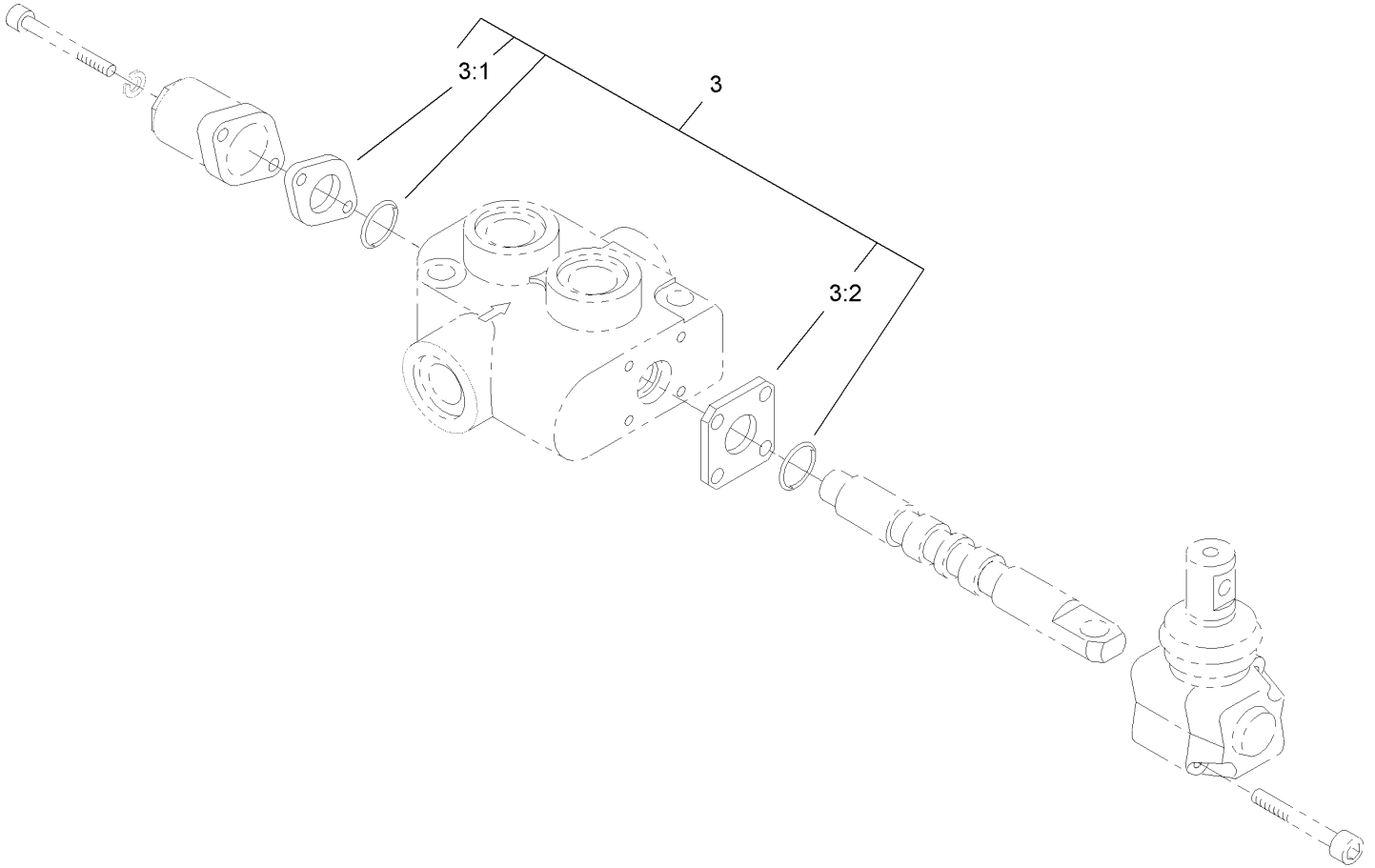

Hydraulic Selector Valve Assembly No. 99-3072

Ref	Part No.	Qty.	Description
3	99-4391	1	Seal Kit
3:1	99-3074	1	Gasket
3:2	99-3075	3	Gasket

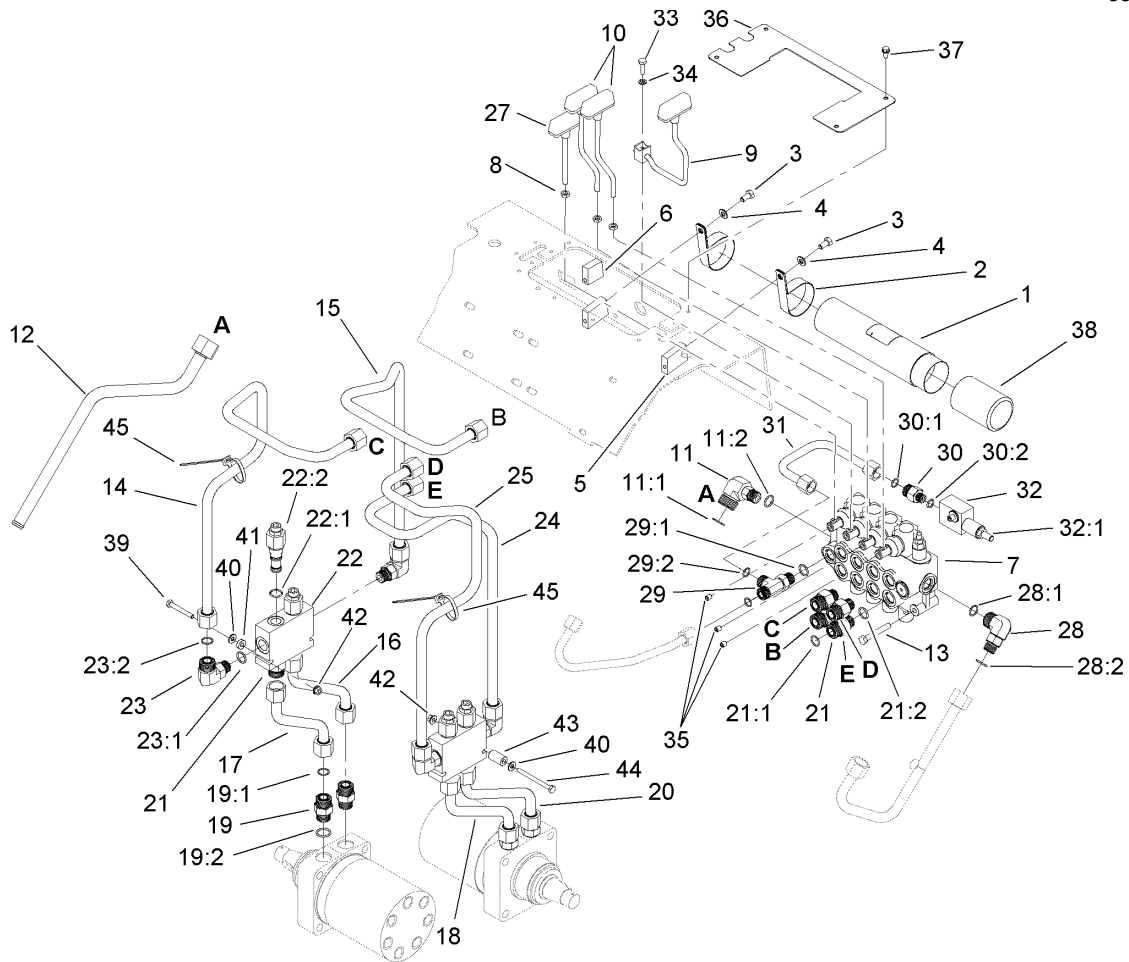

Hydraulic Traction Assembly

Ref	Part No.	Qty.	Description
1	104-7050	1	Housing-Manual
2	2412-133	2	R-Clamp
3	322-2	3	Screw-HH
4	33094-00	5	Washer-Plain
5	108-4728	2	Spacer
6	105-7870	1	Spacer-Upper
7	105-6246	1	Valve-Four Spool (W/ Relief Port)
8	33014-00	3	Nut-Hex
9	106-8165	1	Control Lever ASM
10	104-5733	2	Drive Lever ASM
11	92-5696	1	Fitting-HYD, 90 DEG
11:1	237-58	1	O-Ring
11:2	237-79	1	O-Ring
12	106-8177	1	Tube-Tank, HYD
13	322-11	3	Screw-HH
14	105-7877	1	Tube-HYD (Right B)
15	105-7876	1	Tube-HYD (Right A)
16	98-4740	1	Tube-HYD
17	98-4741	1	Tube-HYD
18	98-4743	1	Tube-HYD
19	340-7	4	Adapter
19:1	237-65	1	O-Ring
19:2	237-80	1	O-Ring
20	98-4742	1	Tube-HYD

Ref	Part No.	Qty.	Description
21	340-155	8	Fitting-HYD, Straight
21:1	237-79	1	O-Ring
21:2	237-151	1	O-Ring
22	98-9050	2	Valve-Counterbalance
22:1	105-4099	1	Seal Kit
22:2	99-3271	2	Valve-Cartridge
23	340-153	4	Fitting-Elbow, 90 DEG
23:1	237-79	1	O-Ring
23:2	237-151	1	O-Ring
24	105-7875	1	Tube-HYD (Left A)
25	105-7874	1	Tube-HYD (Left B)
27	105-7881	1	Cylinder Lever ASM
28	340-153	1	Fitting-Elbow, 90 DEG
28:1	237-79	1	O-Ring
28:2	237-151	1	O-Ring
29	340-109	1	Fitting-HYD, Tee
29:1	237-79	1	O-Ring
29:2	237-30	2	O-Ring
30	340-5	1	Fitting-Straight
30:1	237-42	1	O-Ring
30:2	237-30	1	O-Ring
31	108-4717	1	HYD Tube ASM
32	105-7882	1	Relief Valve ASM
32:1	105-8358	1	Cartridge-Valve, Relief

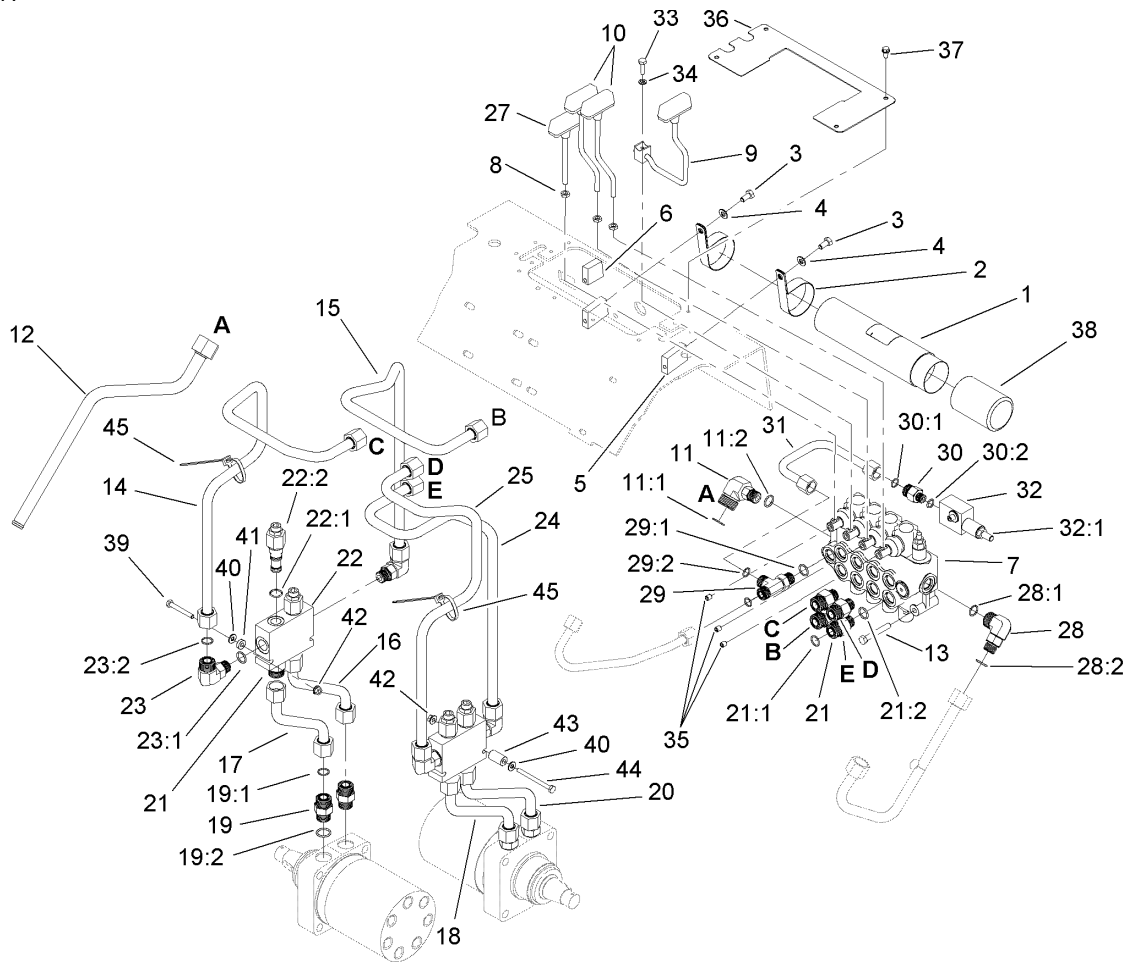

Hydraulic Traction Assembly (continued)

Ref	Part No.	Qty.	Description
● 32:2	105-8357	1	Seal Kit
33	321-5	1	Screw-HH
34	3253-3	1	Washer-Lock
35	105-4068	3	Screw-Set, HSH
36	108-9731-03	1	Plate-Cover
37	32144-4	4	Screw-HWH
38	104-7048	1	Cap-Housing
39	321-11	1	Screw-HH
40	3256-22	2	Washer-Flat
41	106-8189	1	Spacer
42	32128-32	2	Nut-HHF
43	106-8188	1	Spacer
44	321-23	1	Screw-HH
45	3290-379	2	Tie-Cable

--	--	--	--

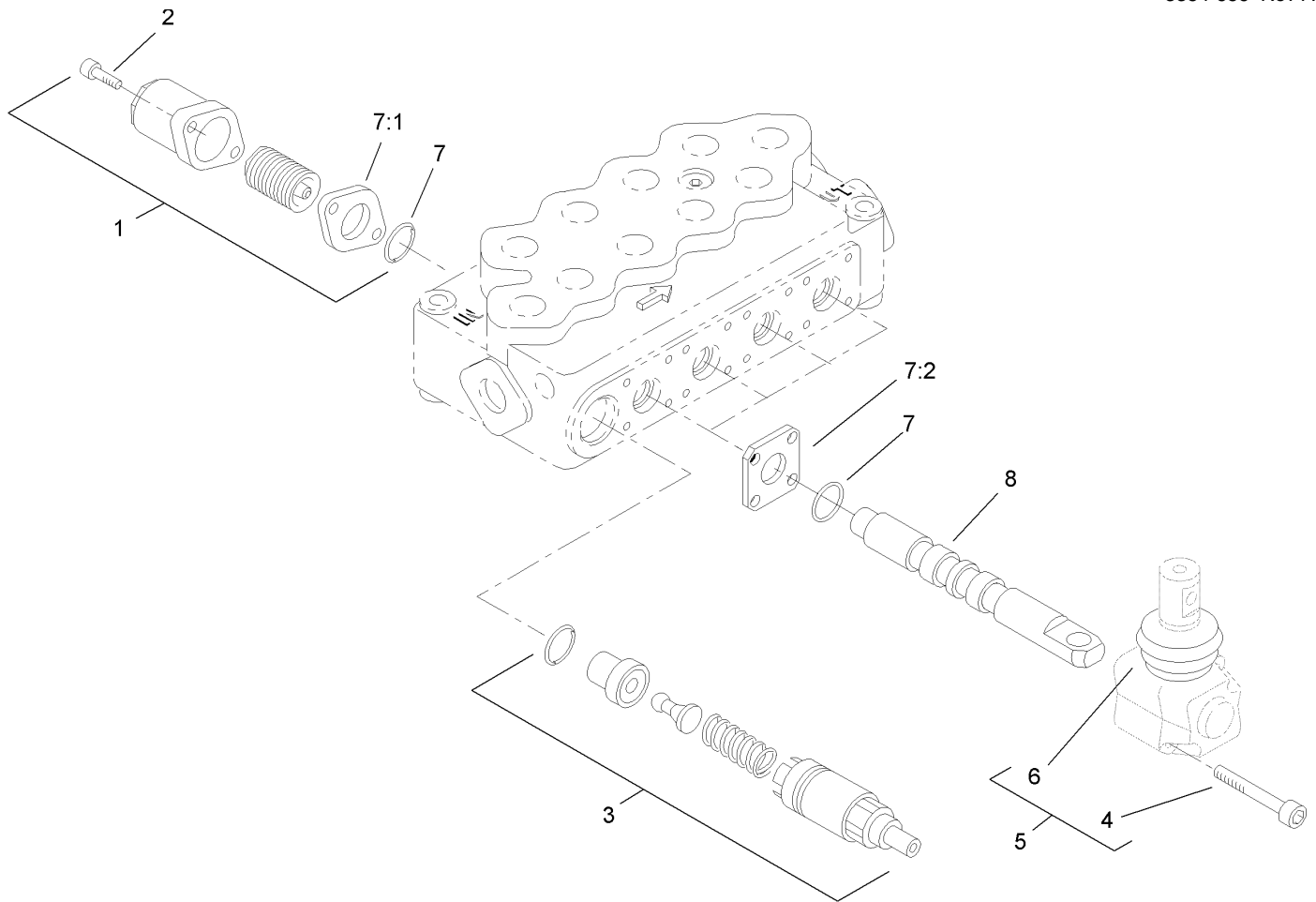

Hydraulic Valve Assembly No. 105-6246

Ref	Part No.	Qty.	Description
1	100-8801	4	High Force Spring Kit
1	100-8800	4	Standard Spring ASM
2	100-8802	8	Screw-Cap, End
3	100-8805	1	Valve-Relief
4	100-8806	8	Screw
5	100-8807	4	Operator ASM
6	100-8829	4	Boot
7	99-4390	1	Seal Kit
7:1	99-3074	4	Gasket
7:2	99-3075	8	Gasket
8	105-8441	4	Spool-Valve

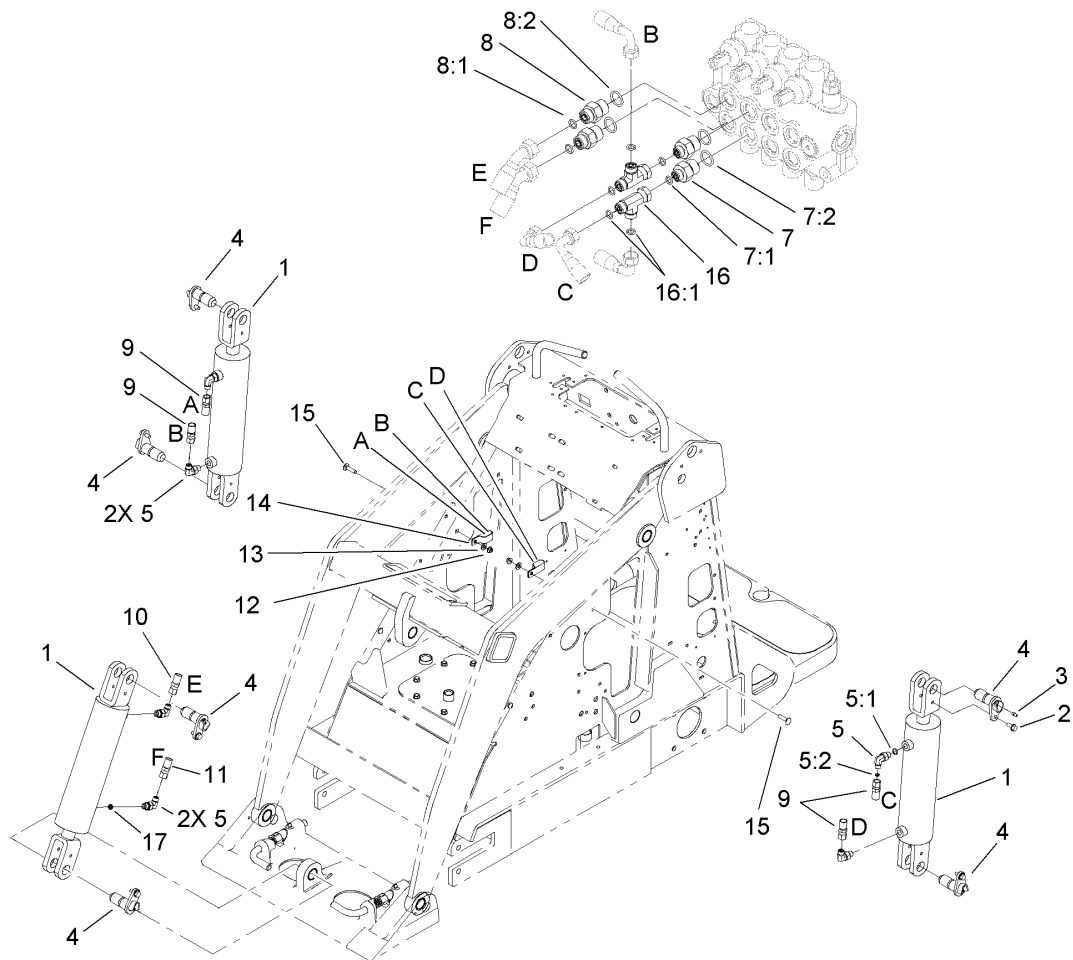

Hydraulic Cylinder Assembly

Ref	Part No.	Qty.	Description
1	105-7867	3	Cylinder-HYD
2	99-5105	6	Bolt-Shoulder
3	302-5	6	Fitting-Grease
4	99-1414	6	Pin-Pivot
5	340-82	6	Adapter
5:1	237-42	1	O-Ring
5:2	237-21	1	O-Ring
7	340-133	2	Adapter
7:1	237-79	1	O-Ring
7:2	237-21	1	O-Ring
8	340-3	2	Adapter
8:1	237-22	1	O-Ring
8:2	237-79	1	O-Ring
9	98-4725	4	Hose-HYD
10	98-4727	1	Hose-HYD
11	98-4726	1	Hose-HYD
12	3296-29	2	Nut-Lock, NI
13	3256-23	2	Washer-Flat
14	2412-137	2	Clamp-Tube
15	3230-3	2	Screw-CARR
16	340-151	2	Fitting
16:1	237-75	3	O-Ring
17	108-4714	1	Orifice-Port Insert, One Way

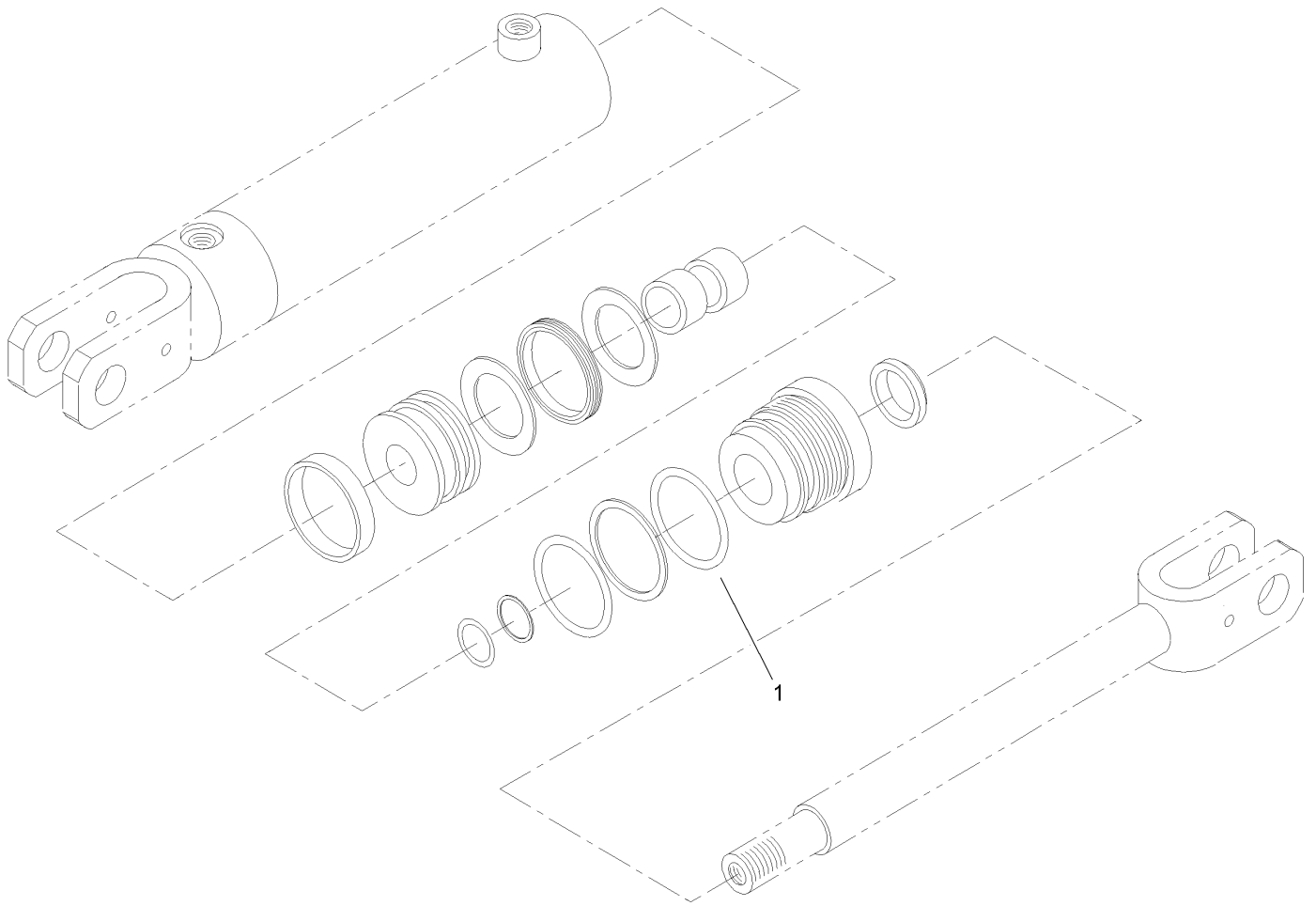

Hydraulic Cylinder Assembly No. 105-7867

Ref	Part No.	Qty.	Description
1	105-8356	1	Seal Kit

Ref	Part No.	Qty.	Description
-----	----------	------	-------------

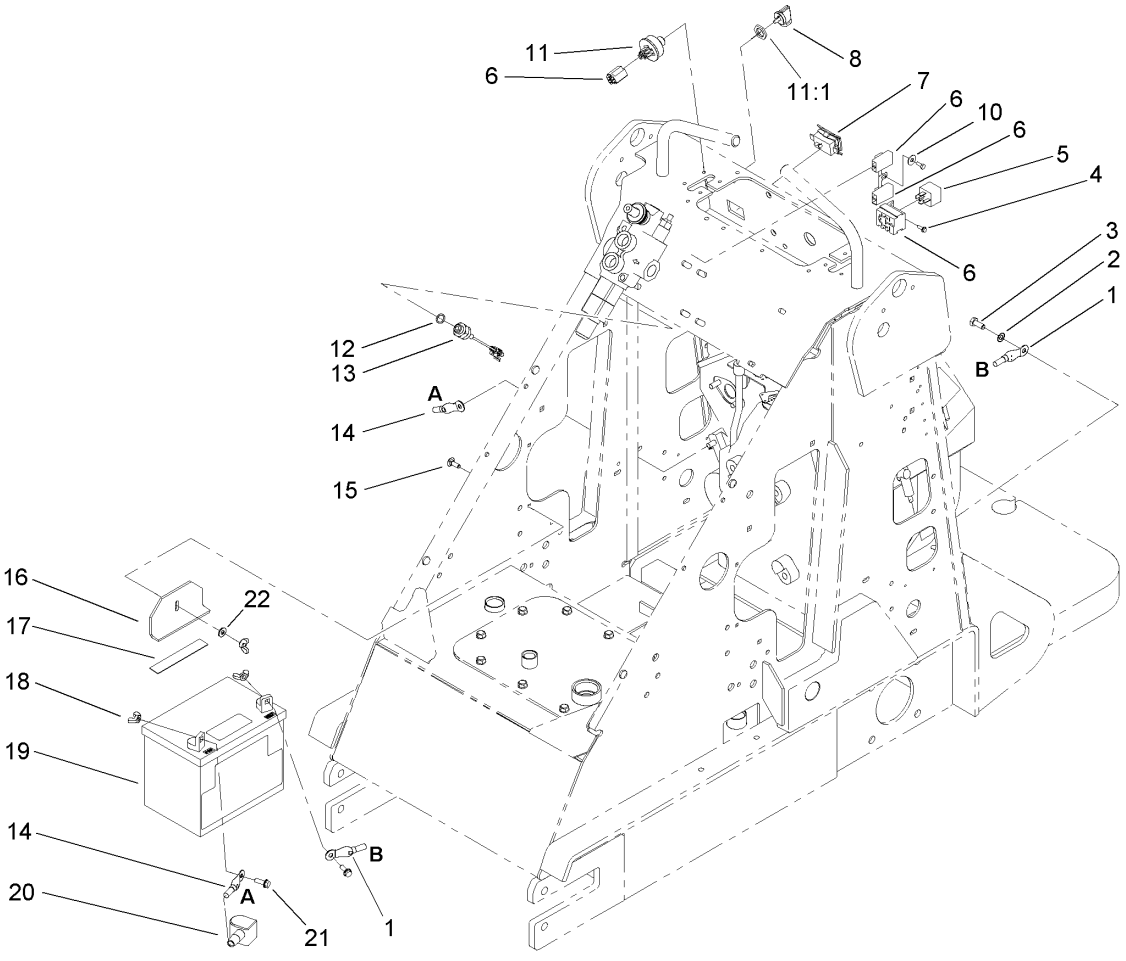

Electrical Assembly

Ref	Part No.	Qty.	Description
1	111074	1	Cable-Black
2	3255-8	1	Washer-Lock
3	33114-020	1	Screw-HH
4	32144-87	2	Screw-HWHTF
5	98-7249	1	Relay
6	98-4650	1	Harness-Electrical
7	106-8175	1	Meter-Hour, Mini Dc
8	63-8360	2	Key-Ignition
10	3256-49	1	Washer-Flat
11	116338	1	Key Switch ASM
11:1	101884	1	Nut
12	237-42	1	O-Ring
13	72-4310	1	Switch-Ball
14	92-6989	1	Wire
15	3229-2	1	Screw-CARR
16	105-8401-03	1	Clamp-Battery
17	94-9566	1	Pad-Footrest
18	32103-22	3	Nut-Wing
19	104-2492	1	Battery
20	77-0981	1	Boot-Terminal, Red
21	3234-4	2	Screw-HHF
22	3256-22	1	Washer-Flat

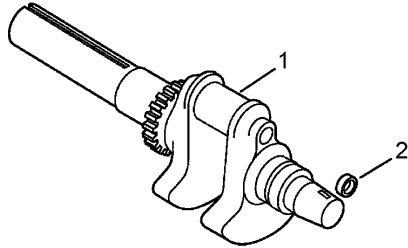

Crankshaft Assembly Kohler CH20S 64733

Ref	Part No.	Qty.	Description				
● 1	24 014 90-S	1	Crankshaft (Includes 2)				
● 2	52 139 09-S	1	Plug-Cup				

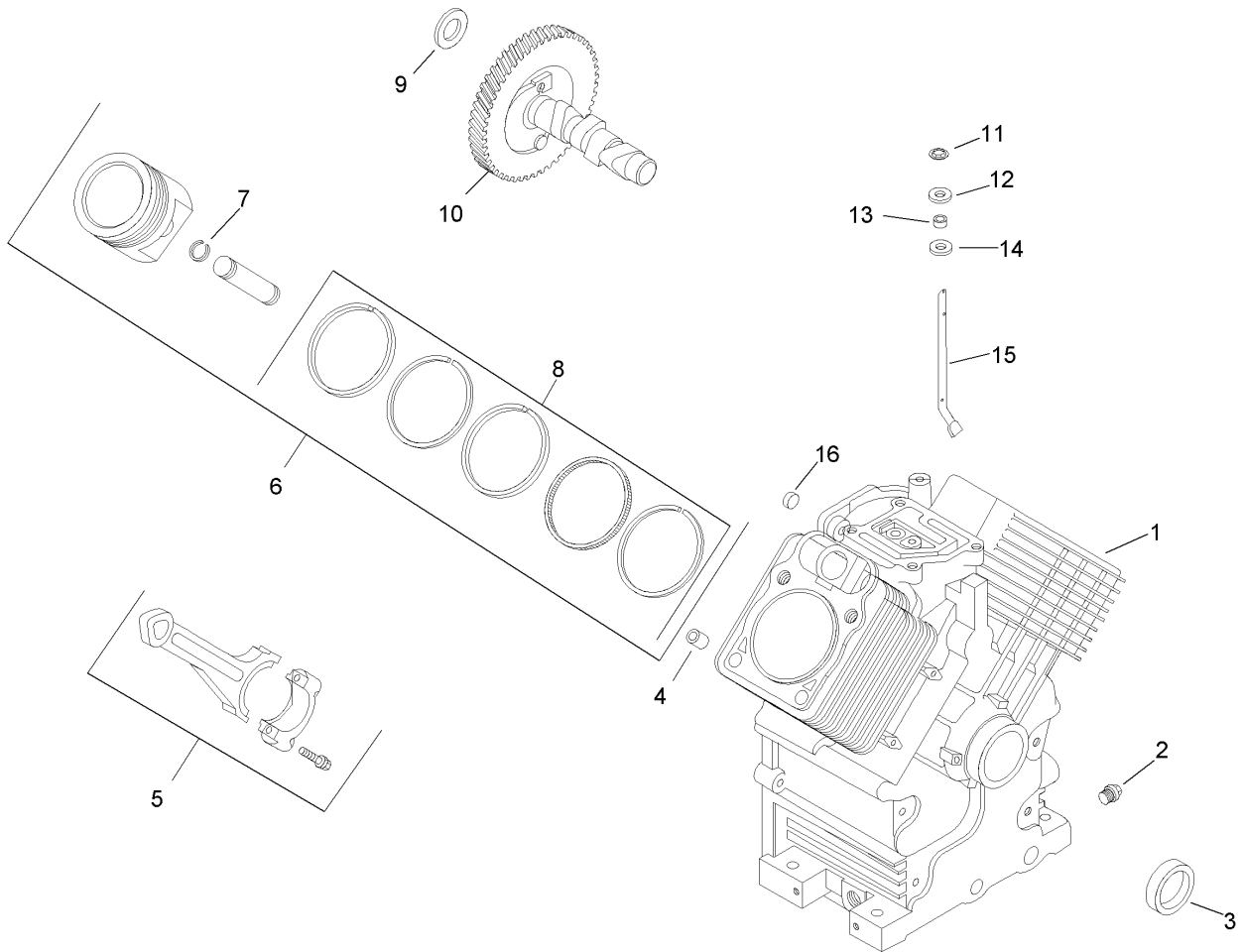

Crankcase Assembly Kohler CH20S 64733

Ref	Part No.	Qty.	Description
② ①		1	Crankcase (Use: Miniblock 24 782 15)
②	52 139 02-S	2	Plug-Pipe
③	24 032 01-S	1	Seal-Oil, Front
④	24 380 13-S	6	Pin-Locating
⑤	24 067 13-S	2	Rod-Connecting (STD)
⑤	24 067 14-S	2	Rod-Connecting (.25)
⑥	24 874 17-S	2	Piston ASM (STD.) (Includes 7,8)
⑥	24 874 14-S	2	Piston ASM (.08)
⑥	24 874 18-S	2	Piston ASM (.25)
⑥	24 874 19-S	2	Piston ASM (.50)
⑦	24 018 01-S	4	Retainer-Pin, Piston
⑧	24 108 11-S	2	Ring Set (STD.)
⑧	24 108 12-S	2	Ring Set (.25)
⑧	24 108 13-S	2	Set-Ring (.50)
⑨	12 422 09-S		Shim-Camshaft, Red
⑨	12 422 13-S		Shim-Camshaft, Black
⑨	12 422 07-S		Shim-Camshaft, White
⑨	12 422 08-S		Shim-Camshaft, Blue
⑨	12 422 10-S	1	Shim-Camshaft, Yellow
⑨	12 422 11-S		Shim-Camshaft, Green
⑨	12 422 12-S		Shim-Camshaft, Gray
⑩	24 012 10-S	1	Camshaft
⑪	24 018 09-S	1	Retainer-Ring

Ref	Part No.	Qty.	Description
⑫	M-931010-S	1	Washer-Plain (Top)
⑬	28 032 09-S	1	Seal-Cross Shaft, Governor
⑭	24 468 15-S	1	Washer-Flat (Bottom)
⑮	24 144 38-S	1	Shaft-Cross, Governor
⑯	52 139 09-S	1	Plug-Cup

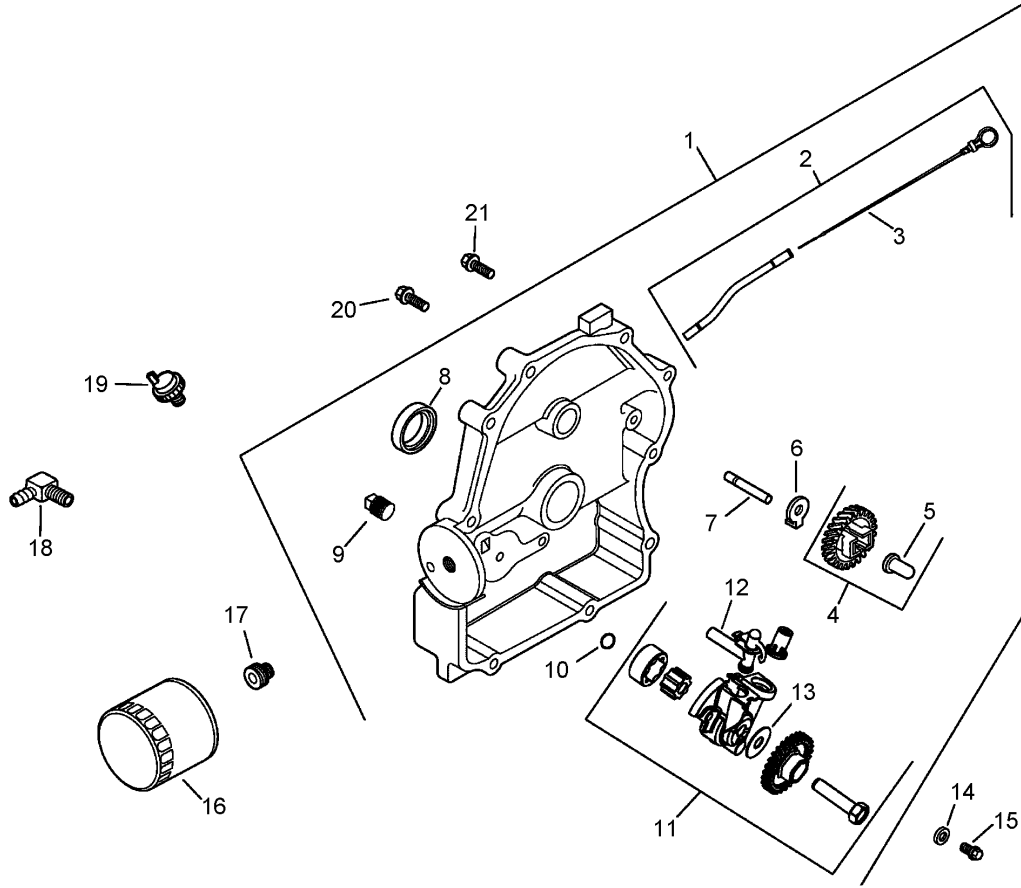

Oil Pan and Lubrication Assembly Kohler CH20S 64733

Ref	Part No.	Qty.	Description
❶	24 009 82-S	1	Closure Plate Kit (Includes 2-13)
❷	24 755 121-S	1	Dipstick Tube ASM (Includes 3)
❸	24 038 10-S	1	Dipstick
❹	24 043 12-S	1	Governor Gear Kit (Includes 5)
❺	12 380 01-S	1	Pin-Regulating, Governor
❻	24 448 02-S	1	Tab-Locking
❼	12 144 02-S	1	Shaft-Gear, Governor
❽	52 032 08-S	1	Seal-Oil
❾	25 139 60-S	2	Plug-Pipe, 1/8In Allen Head
❿	24 153 08-S	1	O-Ring
⓫	24 393 37-S	1	Oil Pump ASM (Includes 12, 13)
⓬	24 381 04-S	1	Pick Up-Oil
⓭	24 153 01-S	1	O-Ring (Oil Pick Up)
⓮	M-631005-S	2	Washer-Plain (6Mm)
⓯	M-645025-S	2	Screw-HF (M6X1.0X25)
⓰	52 050 02-S	1	Filter-Oil
⓱	24 136 01-S	1	Nipple-Filter, Oil
⓲	25 155 02-S	1	Connector
⓳	24 099 03-S	1	Switch-Pressure
⓴	24 086 16-S	9	Screw-HF (M8X1.25X45)
⓵	24 086 17-S	1	Screw-HF (M8X1.25X45)

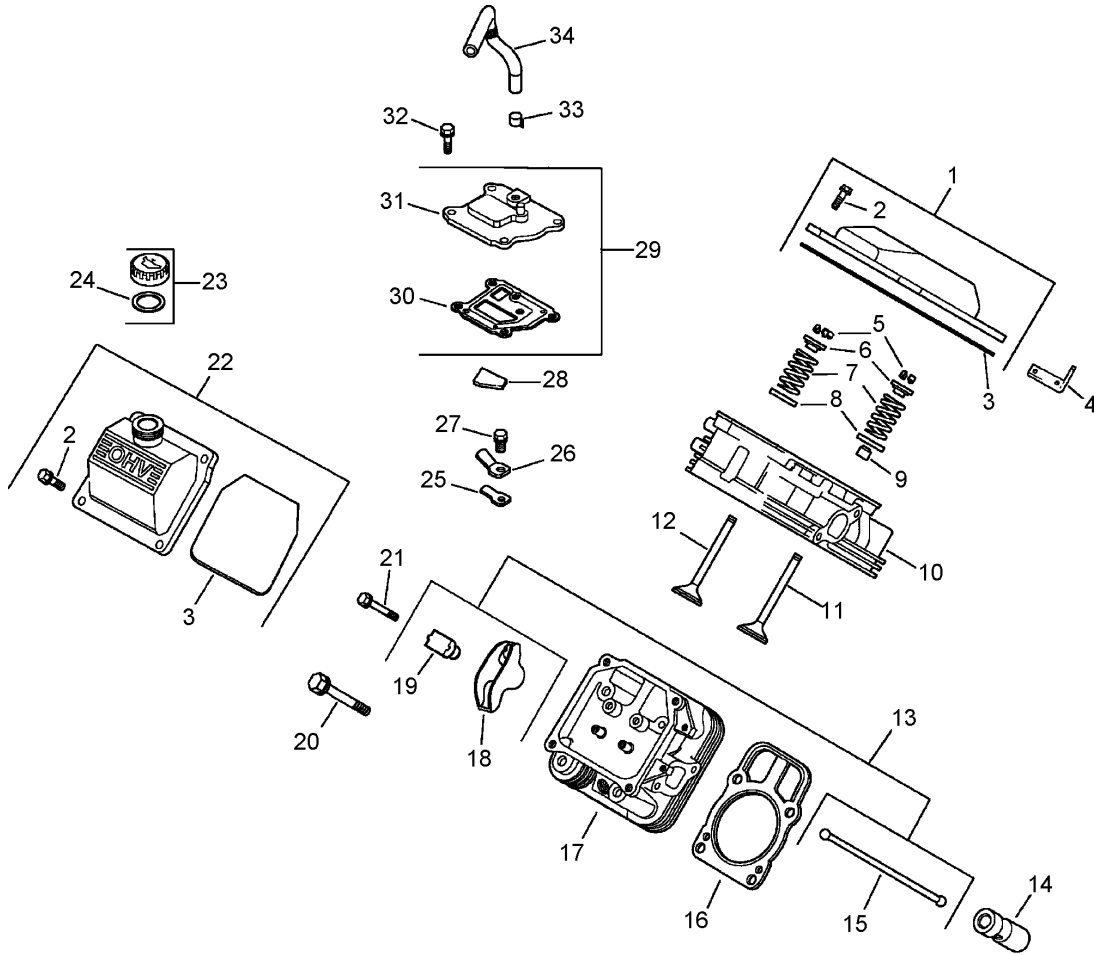

Head, Valve, and Breather Assembly Kohler CH20S 64733

Ref	Part No.	Qty.	Description
❶	24 755 141-S	1	Plain Valve Cover Kit (Includes 2, 3)
❷	M-651030-S	4	Screw-HF (M6X1.0X30)
❸	24 153 28-S	1	O-Ring
❹	24 445 01-S	1	Strap-Lifting
❺	12 755 03-S	4	Retainer Kit
❻	12 173 01-S	4	Cap-Spring, Valve
❼	24 089 02-S	4	Spring-Valve
❽	235011-S	4	Retainer-Spring
❾	66 032 05-S	2	Seal-Stem, Valve
❿	24 318 68-S	1	No. 1 Cylinder Head ASM
⓫	24 017 01-S	2	Valve-Intake (STD)
⓫	24 017 02-S	2	Valve-Intake (.25)
⓬	24 016 01-S	2	Valve-Exhaust (STD)
⓬	24 016 02-S	2	Valve-Exhaust (.25)
⓭	24 755 66-S	1	Valve Train Kit (Includes 15, 18, 19)
⓮	25 351 01-S	4	Lifter-Valve
⓯	24 411 05-S	4	Rod-Push
⓰	24 841 01-S	2	Cylinder Head Gasket Kit (Includes 20)
⓱	24 318 71-S	1	No. 2 Cylinder Head ASM
⓲	25 186 01-S	4	Arm-Rocker
⓳	24 599 01-S	4	Pivot-Arm, Rocker
⓴	12 086 16-S	8	Screw-HF, Reduced

Ref	Part No.	Qty.	Description
⓶	66 086 07-S	4	Screw
⓷	24 755 140-S	1	Oil Fill Valve Cover Kit (Includes 2, 3)
⓸	24 755 46-S	1	Oil Fill Cap Kit (Includes 24)
⓹	25 153 02-S	1	O-Ring
⓺	24 402 03-S	1	Reed-Breather
⓻	66 018 04-S	1	Retainer-Reed, Breather
⓼	M-545010-S	1	Screw-HF (M5X0.8X10)
⓽	24 050 01-S	1	Filter-Breather
⓾	24 033 01-S	1	Breather Kit (Includes 30, 31)
⓿	24 041 51-S	1	Gasket-Breather
⓿	24 096 86-S	1	Cover-Breather
⓿	M-645020-S	4	Screw-HF (M6X1.0X20)
⓿	25 237 14-S	1	Clamp
⓿	24 326 26-S	1	Hose-Breather

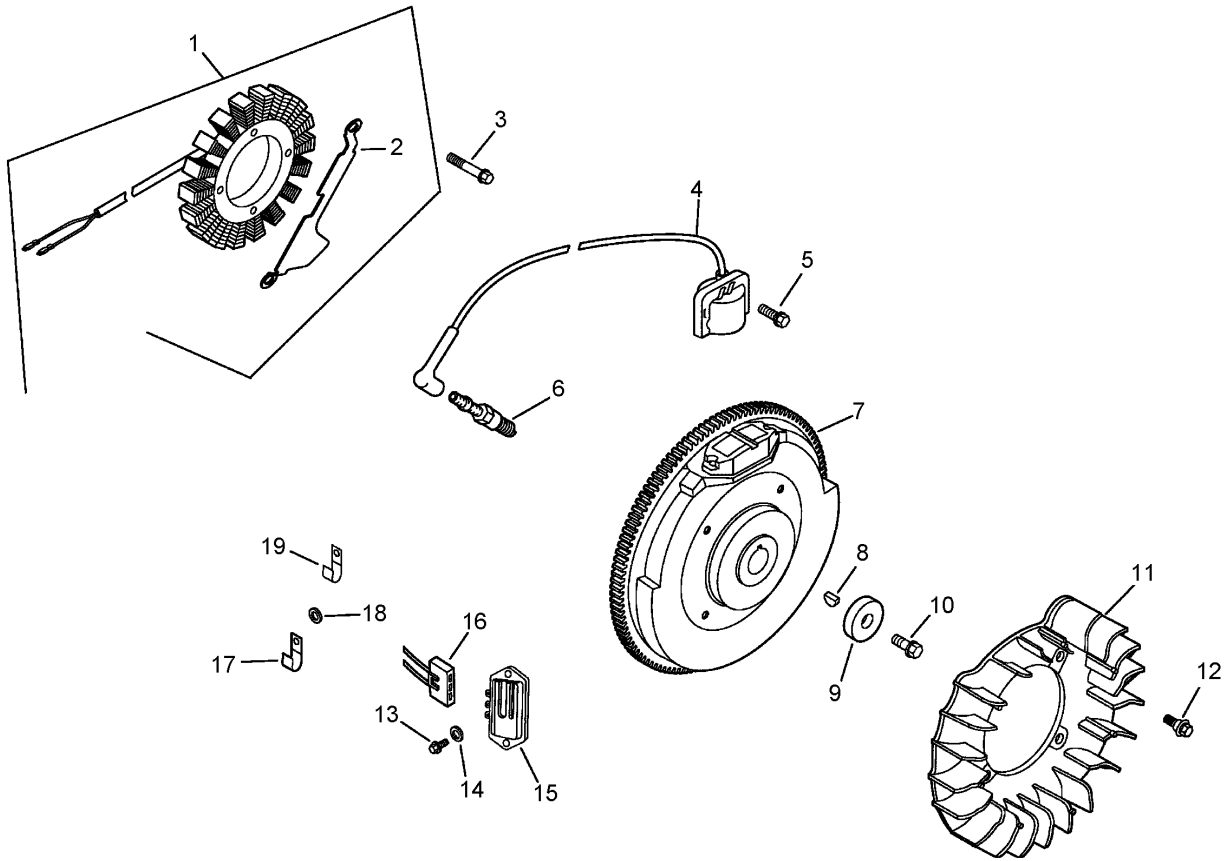

Ignition and Electrical Assembly Kohler CH20S 64733

Ref	Part No.	Qty.	Description
1	54 755 09-S	1	Stator Kit (Includes 2)
2	24 126 139-S	1	Bracket-Wire, Stator
3	M-548025-S	2	Screw (M5X0.8X25)
4	24 584 01-S	2	Module-Ignition
5	M-545020-S	4	Screw-HF (M5X0.8X20)
6	25 132 12-S	2	Spark Plug
7	24 025 01-S	1	Flywheel
8	X-42-15-S	1	Key
9	12 468 03-S	1	Washer-Plain (3/8In)
10	12 086 14-S	1	Screw-HF (M10X1.5X46)
11	24 157 07-S	1	Fan
12	25 086 47-S	4	Bolt-Shoulder (M6X1.0X16)
13	24 086 18-S	2	Screw-Head, Phillips
14	X-25-92-S	2	Washer-Plain
15	41 403 09-S	1	Rectifier-Regulator
16	236602-S	1	Connector
17	235173-S	1	Clip-Cable
18	X-25-63-S	1	Washer-Plain (1/4In)
19	48 154 02-S	1	Clip-Cable (For B+ Lead)
1	24 176 08-S	1	Harness-Wiring
1	24 518 12-S	1	Lead-Black (5In, 12 Gauge, Insulated Grip Barrel Eyelet Terminals))
1	25 454 03-S	2	Tie-Cable

Ref	Part No.	Qty.	Description
1	25 086 91-S	2	Screw (Mounts 5 Wire Connector Of Wiring Harness To Barrel Baffle Above Starter)
1	24 126 137-S	1	Bracket-Strap, Ground
1	25 468 07-S	1	Washer
1	25 113 24-S	1	Decal-Screen, Grass

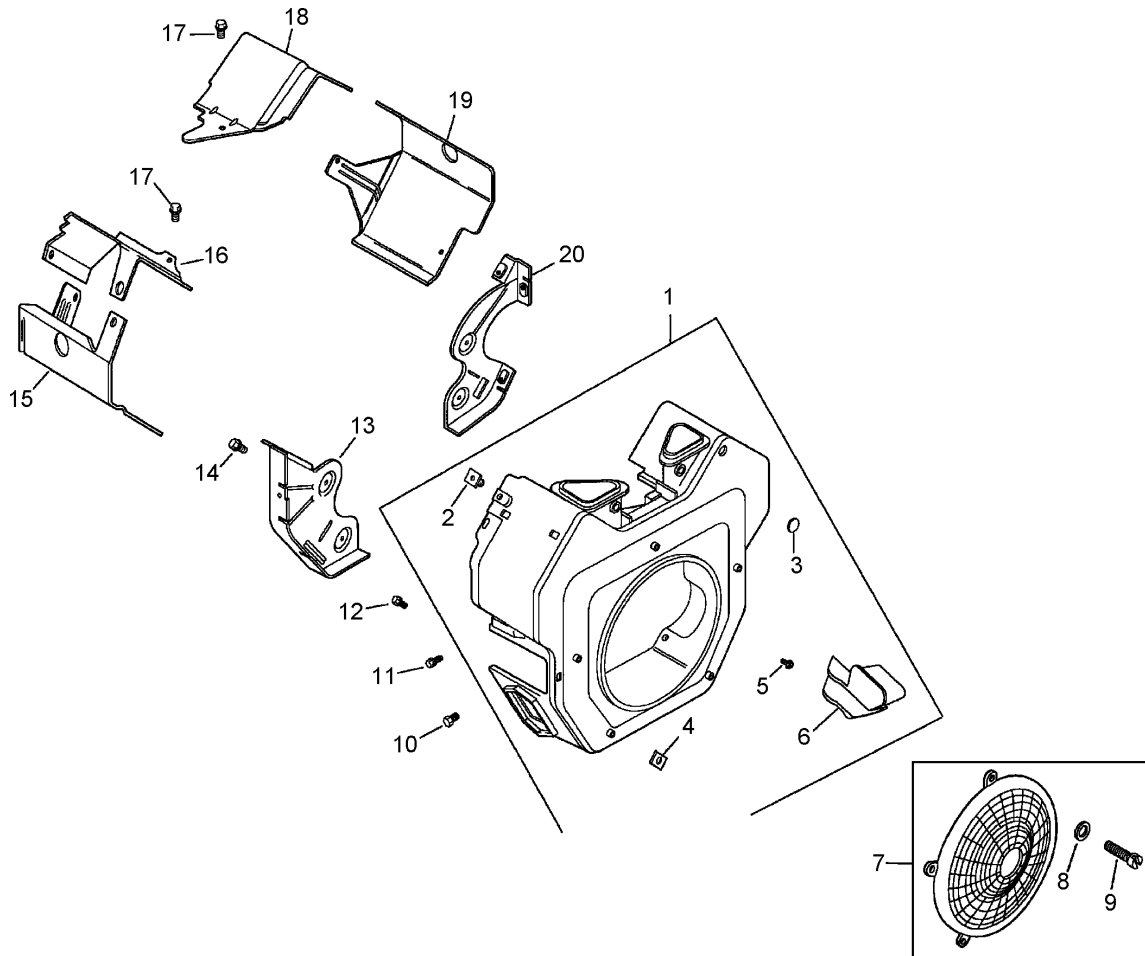

Blower Housing and Baffle Assembly Kohler CH20S 64733

Ref	Part No.	Qty.	Description
❶	24 027 196-S	1	Blower Housing ASM (Includes 2-6, And Insert 24 332 01-S)
❷	25 139 16-S	1	Plug-Button (9/16In)
❸	24 100 01-S	2	Nut-Plastic
❹	24 100 02-S	2	Nut-Plastic
❺	25 086 91-S	1	Screw
❻	24 096 85-S	1	Cover-Housing, Blower
❼	24 755 81-S	1	Fixed Guard Kit (Includes 8, 9, And Insert 24 332 01-S) fixed Guard Kit (Includes 8, 9 And Insert 24 332 01-S)
❽	24 468 10-S	5	Washer-Plain (1/4In)
❾	24 086 35-S	5	Screw-Head, Pan
❿	M-551016-S	1	Screw-HF (M5X0.8X16)
⓫	M-545016-S	3	Screw-HF (M5X0.8X16)
⓬	M-545020-S	4	Screw-HF (M5X0.8X20)
⓭	24 146 16-S	1	Plate-Backing, No. 2 Side
⓮	M-645016-S	6	Screw-HF (M6X1.0X16)
⓯	24 063 20-S	1	Baffle-Cylinder Barrel, No. 2 Side
⓰	24 063 70-S	1	Baffle-Valley (No. 2 Side)
⓱	M-545010-S	2	Screw-HF (M5X0.8X10)
⓲	24 063 59-S	1	Baffle-Valley (No. 1 Side)
⓳	24 063 58-S	1	Baffle-Barrel, Cylinder (No. 1 Side)
⓴	24 146 20-S	1	Plate-Backing (No. 1 Side)

Ref	Part No.	Qty.	Description
❶	24 332 01-S	5	Insert-Threaded
❷	25 113 24-S	1	Decal-Screen, Grass
❸	24 113 95-S	1	Decal-Hp
❹	25 113 39-S	1	Decal-Lamination, Clear

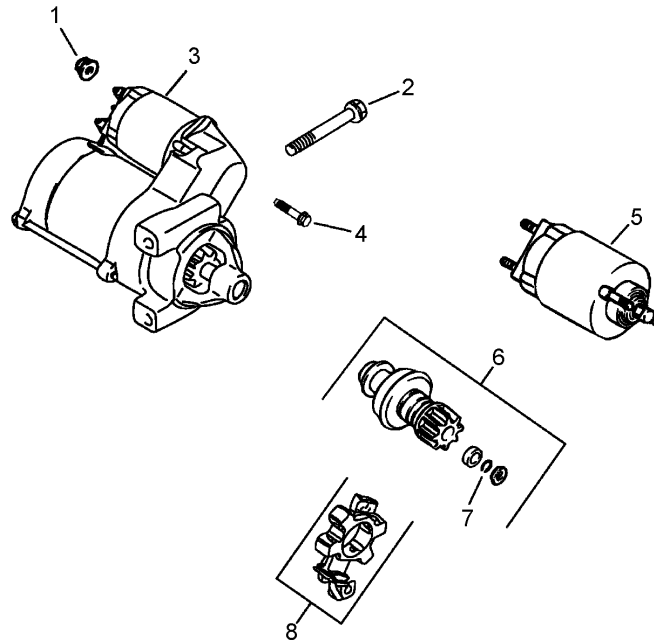

Starting System Assembly Kohler CH20S 64733

Ref	Part No.	Qty.	Description
1	M-841080-S	1	Nut-HF (M8X1.25)
2	M-839080-S	2	Screw-HF (M8X1.25X80)
3	25 098 08-S	1	Starter Solenoid Shift ASM (Includes 4-8)
4	25 086 113-S	3	Screw-Torx Head, External
5	25 435 04-S	1	Solenoid Kit (Includes 4)
6	25 755 33-S	1	Pinion Drive Kit (Includes 7)
7	25 141 05-S	1	Ring
8	25 221 01-S	1	Brush Kit

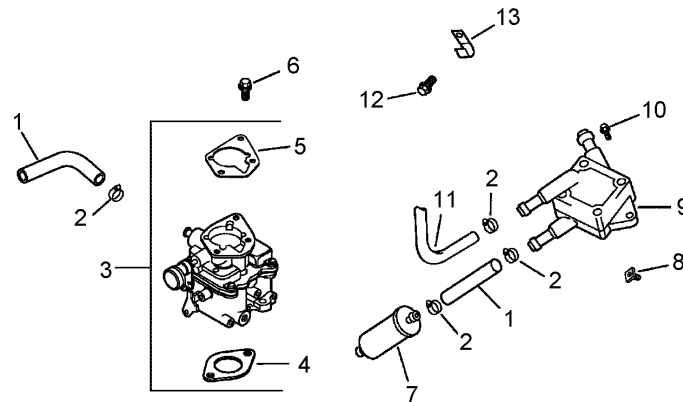

Fuel System Assembly Kohler CH20S 64733

Ref	Part No.	Qty.	Description
1	25 353 32-S	2	Line-Fuel
2	25 237 14-S	6	Clamp
3	24 853 43-S	1	Carburetor Kit (Includes 4, 5)
4	24 041 17-S	1	Gasket-Carburetor
5	24 041 06-S	1	Gasket-Base, Air Cleaner
6	M-651030-S	2	Screw-HF (M6X1.0X30)
7	24 050 02-S	1	Filter-Fuel
8	24 100 01-S	2	Nut-Plastic
9	24 393 16-S	1	Pump-Fuel
10	24 086 12-S	2	Screw
11	24 353 02-S	1	Line-Fuel
12	M-650012-S	1	Screw-HF (M6X1.0X12)
13	47 154 01-S	1	Clip-Cable
14	24 757 01-S	1	Solenoid Kit
15	24 757 02-S	1	Float Repair Kit
16	24 757 03-S	1	Carburetor Repair Kit
17	24 757 07-S	1	Choke Repair Kit
18	24 755 125-S	1	High Altitude Kit

--	--	--	--

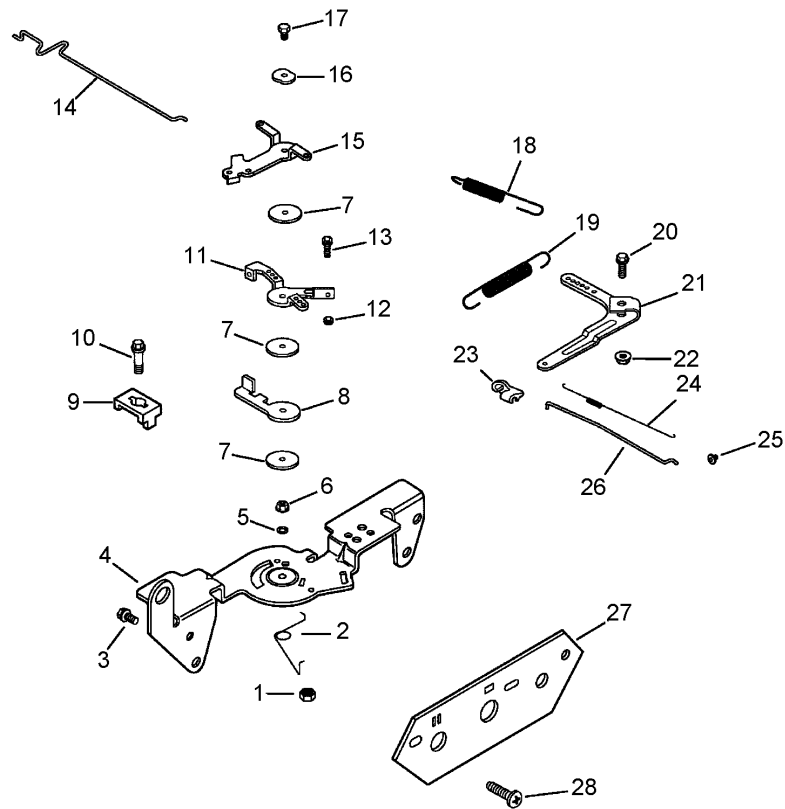

Engine Control Assembly Kohler CH20S 64733

Ref	Part No.	Qty.	Description
1	M-547050-S	1	Nut-Lock, Hex (M5X0.8)
2	24 089 03-S	1	Spring-Return, Choke
3	M-645016-S	4	Screw-HF (M6X1.0X16)
4	24 126 56-S	1	Bracket-Control
5	X-20-1-S	1	Washer-Lock (1/4In)
6	M-541050-S	1	Nut-HF (M5X0.8)
7	24 468 01-S	3	Washer-Plain
8	24 090 07-S	1	Lever-Actuator, Throttle
9	12 237 01-S	2	Clamp-Cable
10	M-545016-S	3	Screw-HF (M5X0.8X16)
11	24 090 03-S	1	Lever-Control, Throttle
12	M-446030-S	1	Nut-HF (M4X0.7)
13	M-403025-S	1	Screw
14	24 079 21-S	1	Linkage-Choke
15	24 090 05-S	1	Lever-Choke
16	41 468 03-S	1	Washer
17	M-545020-S	1	Screw-HF (M5X0.8X20)
18	24 089 51-S	1	Spring-Limiter, Throttle
19	24 089 46-S	1	Spring-Governor
20	24 211 03-S	1	Bolt-Square Neck, Round Head
21	24 090 33-S	1	Lever-Governor
22	M-641060-S	1	Nut-HF
23	25 158 11-S	1	Bushing-Linkage
24	24 089 01-S	1	Spring-Linkage

Ref	Part No.	Qty.	Description
25	25 158 08-S	1	Bushing-Retaining, Linkage
26	24 079 01-S	1	Linkage-Throttle
27	24 378 01-S	1	Panel-Control
28	24 086 06-S	1	Screw-Head, Phillips (11-16X3/4)

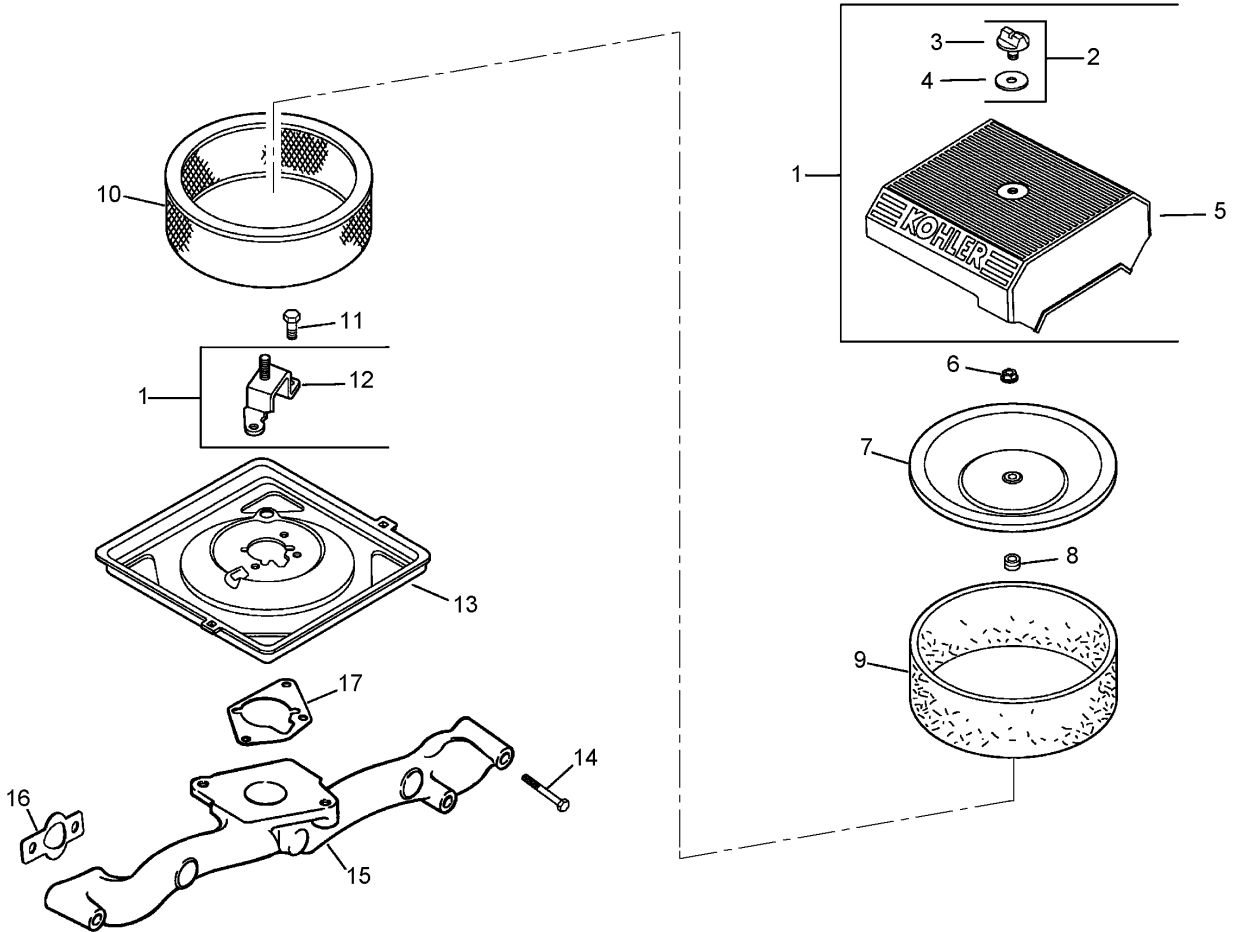

Air Intake and Filtration Assembly Kohler CH20S 64733

Ref	Part No.	Qty.	Description
1	24 743 06-S	1	Air Cleaner Cover Kit (Includes 2-5, 12)
2	54 755 01-S	1	Knob Kit (Includes 3, 4)
3	25 341 04-S	1	Knob-Cover
4	24 153 20-S	1	Seal
5	24 096 67-S	1	Cover-Cleaner, Air
6	M-641060-S	1	Nut-HF
7	24 096 01-S	1	Cover-Air Cleaner, Inner
8	230046-S-S	1	Seal
9	24 083 05-S	1	Element-Precleaner
10	24 083 03-S	1	Element-Cleaner, Air
11	24 086 53-S	3	Screw
12	24 126 141-S	1	Bracket-Base, Air Cleaner
13	24 094 37-S	1	Base-Cleaner, Air
14	25 086 84-S	4	Screw-HF (M6X1.0X55)
15	24 164 14-S	1	Manifold-Intake
16	24 041 01-S	2	Gasket-Manifold, Intake
17	24 041 06-S	1	Gasket-Base, Air Cleaner

--	--	--	--

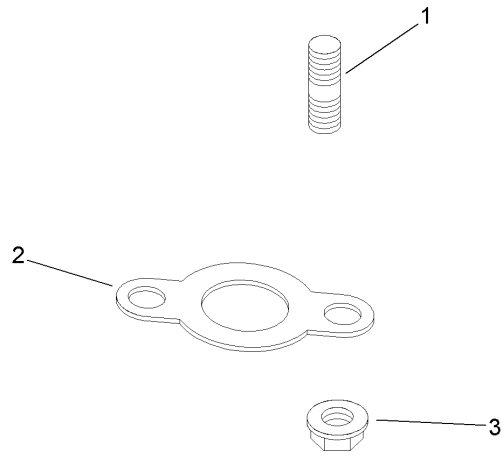

Exhaust Assembly Kohler CH20S 64733

Ref	Part No.	Qty.	Description
③1	25 072 04-S	4	Stud (M8X1.25X33)
③2	24 041 49-S	2	Gasket-Exhaust
③3	M-841080-S	4	Nut-HF (M8X1.25)
①⑤	24 522 181	1	Short Block
①⑤	24 782 15	1	Miniblock
①⑤	24 755 107-S	1	Gasket Set

Attachments and Accessories

For 22317 - Dingo 220 Compact Utility Loader

Product Name	Model/Part
Tire Chain Kit	100-4140
Helmet-Face Shield	100-4143
Light Kit	100-8940
Narrow Tire ASM	104-0572
Remote Air Cleaner Kit	104-4635
Thigh Support Kit	105-0330
Tube-Tire (18 x 8.50-10)	105-4070
Rubber Foot Mat	105-5805
Tube-Tire (18 X 8.50-8)	106396
4 Cubic Foot Standard Bucket	22409
Loose Materials Bucket	22410
48 Inch Hydraulic Blade	22414
Rotary Broom	22415
Counterweight	22417
Bore Drive Head	22420
Rod And Reamer	22421
Multi-Purpose Tool	22423
Power Box Rake	22425
Stump Grinder	22429
Tree Forks	22438
Cement Bowl	22442
The Eliminator Scarifier/Groomer	22443
40 Inch Tiller	22445
Snowthrower	22456
Trencher Head	22470
High-Speed Trencher Head	22471
Narrow Bucket	22520
Auger Head	22802
Universal Swivel Auger Head	22803
Vibratory Plow	22910
Soil Cultivator	23101
Seeder Box Kit, Soil Cultivator	23120
Concrete Breaker	23135
Backhoe	23163
Adjustable Forks	23164
Leveler	23165
LH Wheel And Tire ASM	98-2747
Wheel and Tire ASM	98-4709
Spark Arrestor (Meets USDA Forest Service Standard 5100-1A)	98-9099
RH Wheel And Tire ASM	99-1447
RH Wheel And Tire ASM (Powerlug)	99-3140
LH Wheel And Tire ASM (Powerlug)	99-3141
Hydraulic Relief Valve Kit	99-4360

NOTES

