



## TX 413 Compact Utility Loader

Model No. 22330 - 260000001 and up.

### Parts Catalog

---

#### **Ordering Replacement Parts**

To order replacement parts, please supply the part number, the quantity, and the description of each part desired.

#### **Understanding Reference Numbers**

Each identified part in an illustration has a reference number. The reference number for a part also appears in the parts list, along with other information about the part.

This catalog uses two special reference number formats, one to indicate parts in a service assembly and another to indicate the quantity of a given part in an illustration.

#### **Service Assembly Reference Numbers**

Parts in service assemblies have reference numbers in the form a:b. The a represents the reference number of the entire service assembly and the b represents a sequential number unique to each part within the service assembly.

For example, a wheel assembly might be identified by reference number 6, the tire by 6:1, the valve by 6:2, and the wheel by 6:3. When you order the assembly identified by reference number 6, you receive all parts identified by reference numbers 6:1, 6:2, and 6:3. However, you may also order any part individually. Reference numbers of this type appear in illustrations and in part lists.

#### **Reference Numbers Indicating Quantity**

In an illustration, if a reference number indicates more than one part, the reference number has the form nX y. The n represents the quantity of the part, the X is the multiplication symbol, and the y represents the reference number.

For example, in an illustration, the reference number 2X 37 means that two of the parts identified by reference number 37 are indicated.

# Contents

Description	Page	Description	Page
Frame Assembly	3	Ignition Coil Assembly Honda GX390K1QNE2	24
Track and Traction Assembly	5	Starter Motor Assembly Honda GX390K1QNE2	25
Engine and Drive Assembly	6	Control Assembly Honda GX390K1QNE2	26
Loader Arm and Quick Attach Assembly	7	Miscellaneous Part Assembly Honda GX390K1QNE2	27
Loader Arm Hydraulic Assembly	8	Cylinder Barrel Assembly Honda GX390K1QNE2	28
Valve Assembly No. 106-9406	9	Crankcase Cover Assembly Honda GX390K1QNE2	29
Traction Control Assembly	10	Crankshaft Assembly Honda GX390K1QNE2	30
Control Panel Assembly	11	Piston Assembly Honda GX390K1QNE2	31
Hood and Brake Assembly	12	Camshaft Assembly Honda GX390K1QNE2	32
Electrical Assembly	14	Fan Cover Assembly Honda GX390K1QNE2	33
Traction Hydraulic Assembly	15	Carburetor Assembly Honda GX390K1QNE2	34
Hydraulic Motor Assembly No. 104-8470	16	Air Cleaner Assembly Honda GX390K1QNE2	35
Hydraulic Pump Assembly No. 106-9471	17	Attachments and Accessories List	36
Principle Hydraulic Assembly	18		
Spool Valve Assembly No. 106-9405	19		
Fuel Tank Assembly	20		
Cylinder Head Assembly Honda GX390K1QNE2	21		
Muffler Assembly Honda GX390K1QNE2	22		
Flywheel Assembly Honda GX390K1QNE2	23		

## Part Description Abbreviations

Part descriptions in this catalog may include the following abbreviations.

AR. .... as required	INC. .... incorporated
ASM. .... assembly	LH. .... left hand
BBC. .... blade brake clutch	NI. .... nylon insert
CARR. .... carriage	NPTF. .... national pipe thread fine
DEG. .... degrees	PFH. .... phillips flat head
EXT. .... external	PPH. .... phillips pan head
FH. .... flat head	PPHTF. .... phillips pan head thread forming
GA. .... gauge	PRH. .... phillips round head
HF. .... hex flange	PTH. .... phillips truss head
HH. .... hex head	PTO. .... power-take-off
HHF. .... hex head flange	RH. .... right hand
HHFTF. .... hex head flange thread forming	ROPS. .... roll-over-protection-system
HJ. .... hex jam	SFH. .... slotted fillister head
HLH. .... hex lag head	SHH. .... slotted hex head
HOC. .... height-of-cut	SHWH. .... slotted hex washer head
HSBH. .... hex socket button head	SPH. .... slotted pan head
HSFH. .... hex socket flat head	SQH. .... square head
HSH. .... hex socket head	SRH. .... slotted round head
HWH. .... hex washer head	STD. .... standard
HWHTF. .... hex washer head thread forming	TAP. .... self tapping
HYD. .... hydraulic	TTH. .... torx truss head

## Footnotes

❶ Not illustrated

❷ Obtain Parts From Honda

❸ Not serviced separately

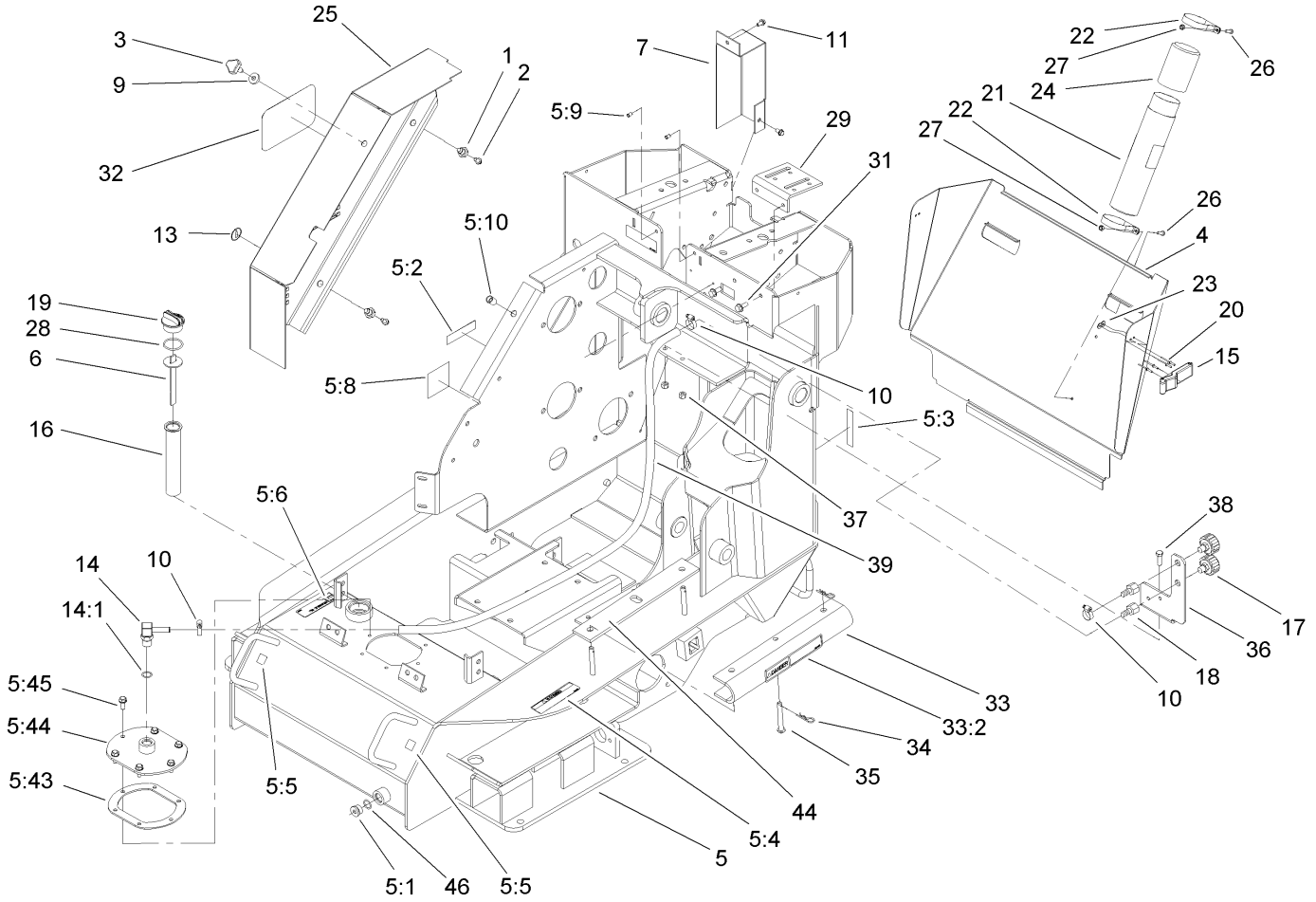

### Frame Assembly

Ref	Part No.	Qty.	Description
1	95-3989	2	Mount-Sidepanel
2	46-8093	2	Screw-Plastite
3	95-9648	1	Knob
4	106-9472-01	1	Cover-Rear
5	106-9530	1	Frame ASM
5:1	353-550	1	Plug-HYD, HH
5:2	98-5954	1	Decal-Cover, Missing
5:3	104-2838	1	Decal-Brake
5:4	100-6141	1	Decal-Pinch
5:5	93-9084	4	Decal-Point, Lift
5:6	105-8432	1	Decal-Oil, HYD
5:8	106-9514	1	Decal-Belt Routing
5:9	32148-6	2	Insert-Nut
5:10	32148-9	1	Insert-Nut
5:43	107-3557	1	Gasket-Cover, Access
5:44	107-3559	1	Cover ASM
5:45	98-9940	6	Screw
6	100-2097	1	Dipstick-Oil
7	105-9043-03	1	Cover-Pulley
9	106-0565	1	Washer-Rubber
10	92-2379	3	Clamp-Hose
11	32144-4	2	Screw-HWH
13	58-6520	1	Decal-Grease
14	354-134	1	Fitting-HYD, 90 DEG

Ref	Part No.	Qty.	Description
14:1	237-79	1	O-Ring
15	80-6980	2	Latch
16	61-2790	1	Filter-Screen
17	68-6150	2	Breather
18	354-95	2	Fitting-Female, Barbed
19	93-7498	1	Plug-Plastic
20	3269-17	8	Rivet-Pop
21	104-7050	1	Housing-Manual
22	2412-120	2	R-Clamp
23	3269-10	8	Washer-Back
24	104-7048	1	Cap-Housing
25	106-9427-03	1	Cover-Belt
26	3290-500	2	Screw-PPH
27	3296-2	2	Nut-Lock
28	237-123	1	O-Ring
29	106-9447-01	1	Bracket-Mount, Throttle
31	32144-70	2	Screw-HH
32	105-1217	1	Decal
33	107-3552	1	Locking Arm ASM
33:2	100-6135	1	Decal-Danger
34	3290-467	3	Pin-Hair
35	283-52	1	Pin-Clevis
36	106-3132-01	1	Bracket-Filter
37	3296-29	2	Nut-Lock, NI

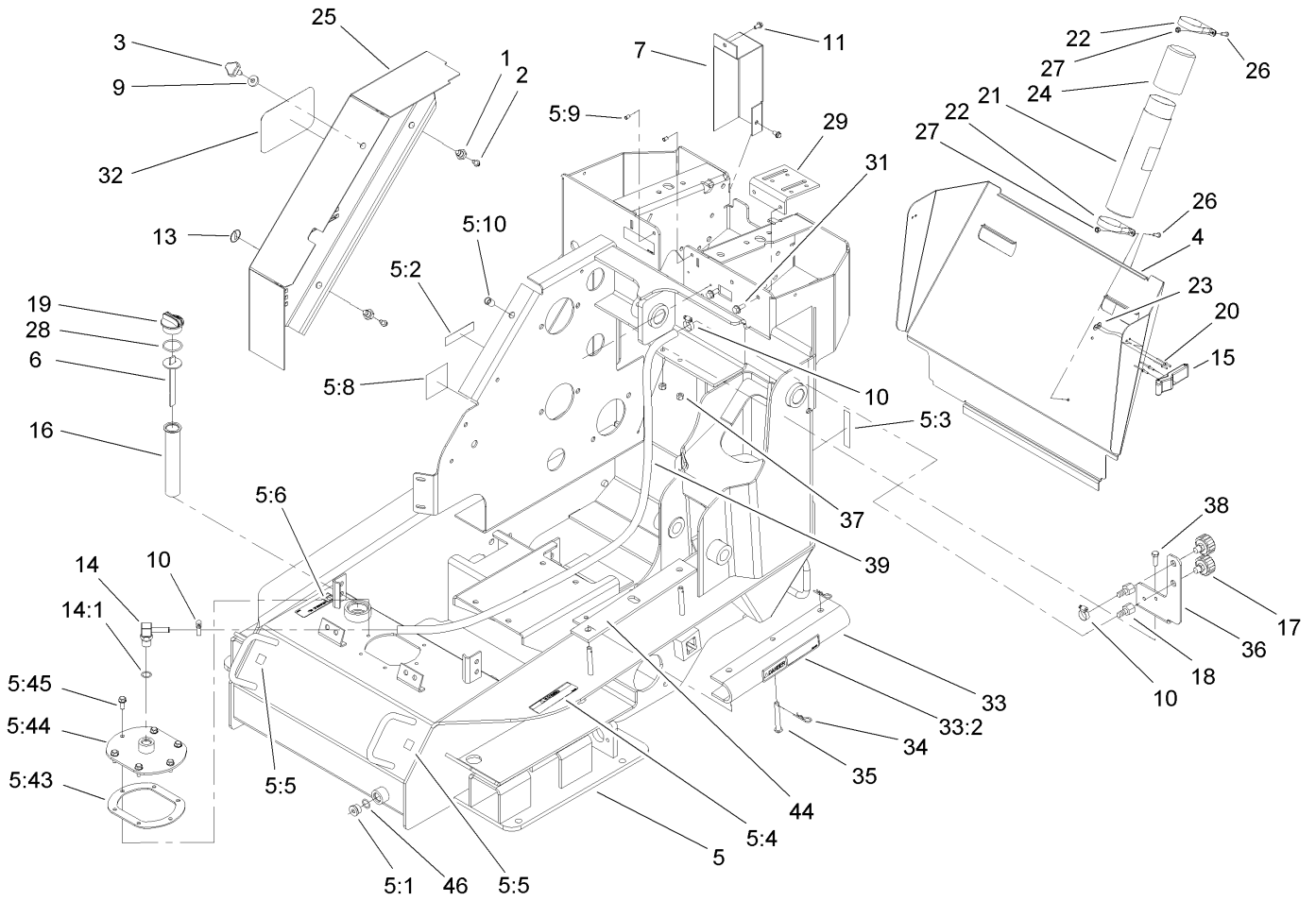

### Frame Assembly (continued)

Ref	Part No.	Qty.	Description
38	322-5	2	Screw-HH
39	103-1693	1	Hose-Fuel
44	106-9495	1	Pad-Rubber
46	237-79	1	O-Ring

Ref	Part No.	Qty.	Description

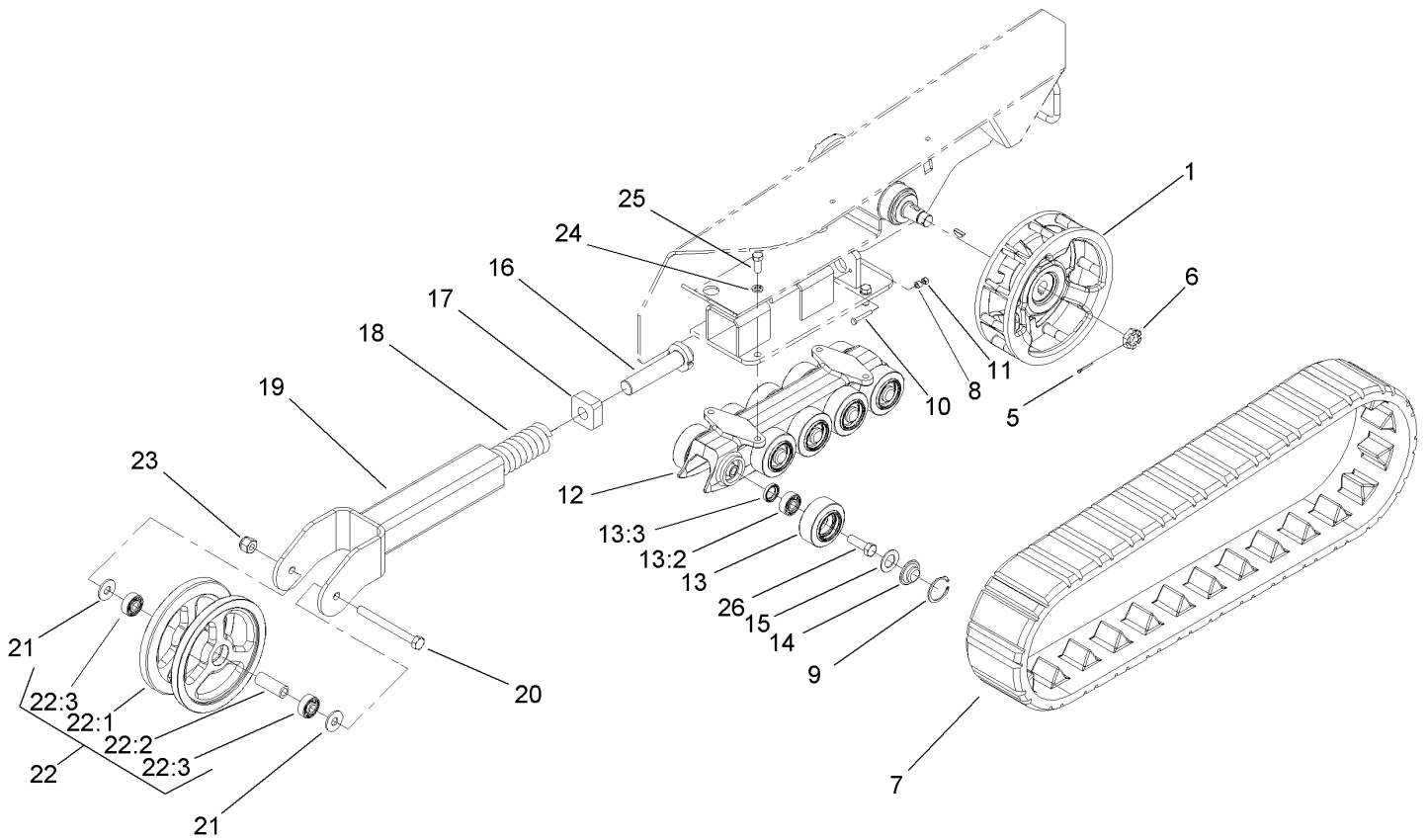

## Track and Traction Assembly

Ref	Part No.	Qty.	Description
1	108-5648-03	2	Wheel-Drive
5	3272-13	2	Pin-Cotter
6	99-3139	2	Nut
7	98-9800	2	Track
8	98-4799	2	Tube-Spacer
9	106-7595	20	Ring-Snap, Internal
10	321-10	2	Screw-HH
11	3296-42	2	Nut-Lock, NI
12	106-7590-03	2	Guide-Track
13	106-7621	20	Road Wheel ASM
13:2	93-4237	1	Bearing
13:3	253-118	1	Seal-Oil
14	106-7557	20	Cap-Wheel, Bearing
15	106-7585	20	Gasket-Bogie
16	98-9846	2	Bolt-Tensioner
17	95-3626	2	Block-Tensioner
18	95-3624	2	Spring-Compression
19	98-9801-03	2	Tensioner Arm ASM
20	327-17	2	Screw-HH
21	3256-7	4	Washer-Flat
22	104-5745	2	Tensioner Wheel ASM
22:1	104-5747-03	1	Wheel-Tensioner
22:2	98-9835	1	Spacer-Wheel, Tensioner
22:3	93-4237	2	Bearing

Ref	Part No.	Qty.	Description
23	3296-24	2	Nut-Lock NI
24	3253-7	8	Washer-Lock
25	325-5	8	Screw-HH
26	327-4	20	Screw-HH

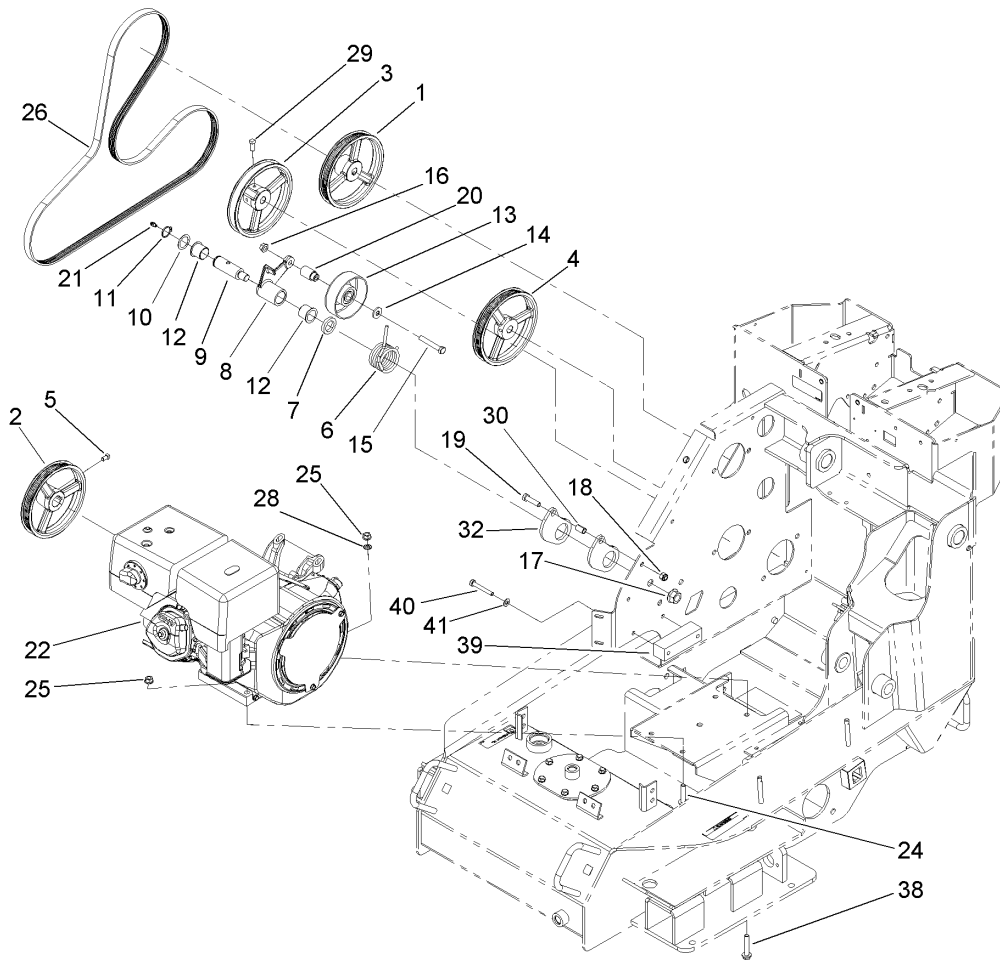

## Engine and Drive Assembly

Ref	Part No.	Qty.	Description
1	104-8448	1	Pulley
2	104-8449	1	Pulley
3	104-8450	1	Pulley
4	105-9046	1	Pulley
5	3242-2	2	Screw-SQH
6	100-4844	1	Spring-Torsion
7	99-3625	1	Spacer-Arm, Idler
8	99-3623-03	1	Arm-Idler
9	99-3624	1	Shaft-Pivot, Idler
10	74-1810	1	Washer
11	32151-36	1	Ring-Retaining
12	99-3631	2	Bushing-Flange
13	95-8802	1	Pulley-Idler
14	80-6990	1	Washer-Hardened
15	323-12	1	Screw-HH
16	32128-21	1	Nut-HF
17	32128-54	1	Nut-HF
18	3296-39	1	Nut-Lock, NI
19	323-8	1	Screw-HH
20	105-9035	1	Spacer-Idler
21	302-5	1	Fitting-Grease
 22		1	Engine-Honda, Gx390K1Qne2
24	3234-19	3	Screw-HHF
25	32128-21	4	Nut-HF

Ref	Part No.	Qty.	Description
26	106-9422	1	Belt-Poly-V
28	3255-9	1	Washer-Lock, EXT
29	3242-4	6	Screw-Set, SQH
30	106-4501	1	Spacer-Scraper, Stop
32	106-9480	2	Pad-Rubber
38	66-9302	1	Screw-HHF, Whiz
39	108-6322	1	Spacer-Mount
40	3210-11	2	Screw-HH
41	3256-23	2	Washer-Flat

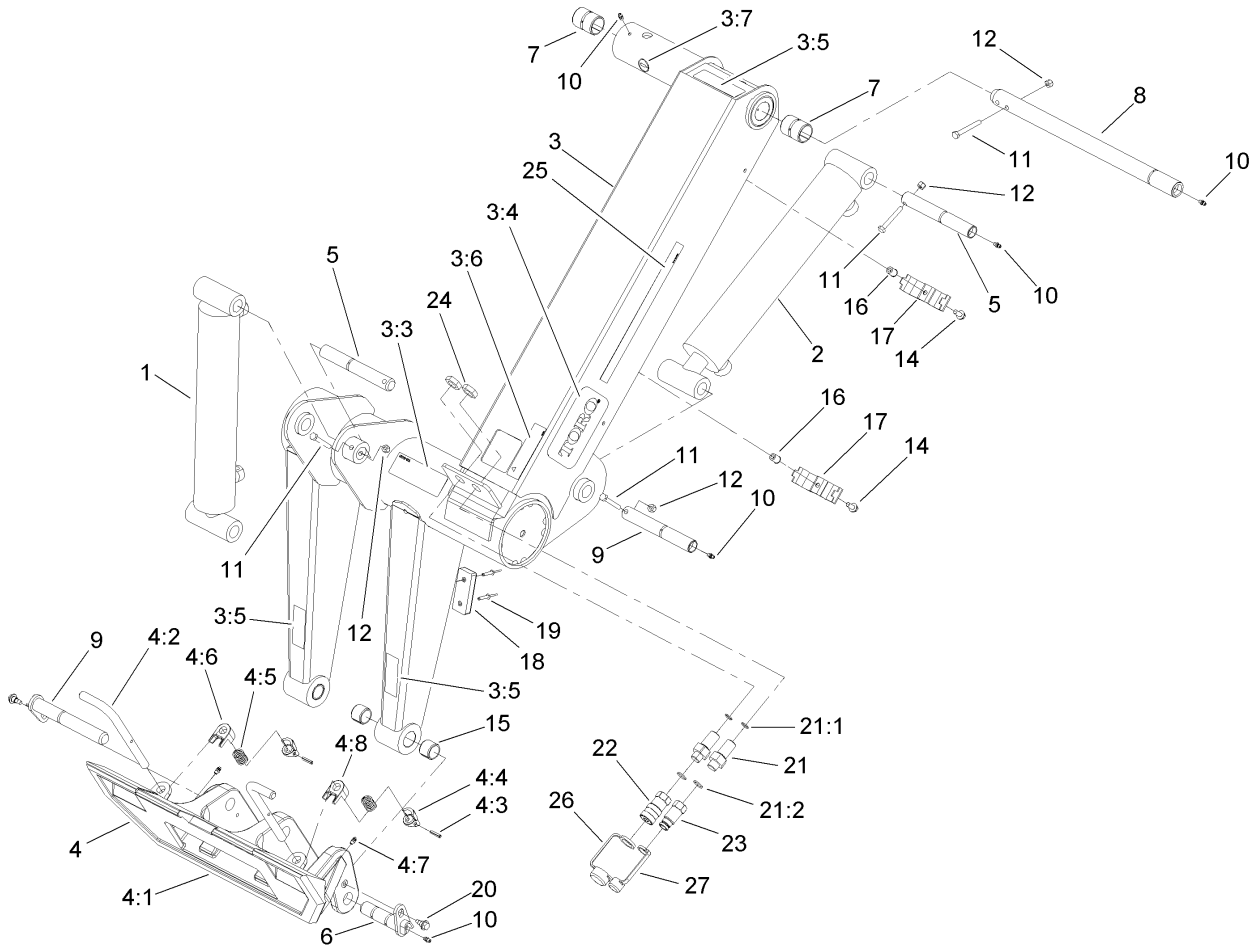

## Loader Arm and Quick Attach Assembly

Ref	Part No.	Qty.	Description
1	106-3161	1	Cylinder-HYD
1:1	106-9466	1	Seal Kit
2	106-3162	1	Cylinder-HYD
2:1	106-9467	1	Seal Kit
3	108-4633	1	Loader Arm ASM
3:3	106-9451	1	Decal-Caution
3:4	105-1217	1	Decal
3:5	100-6141	3	Decal-Pinch
3:6	100-6101	1	Decal-Caution
3:7	58-6520	1	Decal-Grease
4	106-9426	1	Quick Attach ASM
4:1	106-3156-03	1	Mount-Qtach
4:2	105-8367	2	Pin-Locking
4:3	3285-1	2	Pin-Grooved
4:4	105-0246	2	Cam
4:5	98-4694	2	Spring-Compression
4:6	104-5909	1	Stop-RH
4:7	302-5	2	Fitting-Grease
4:8	104-5903	1	Stop-LH
5	105-9075	3	Pin-Pivot
6	106-3139	2	Pivot Pin ASM
7	106-3133	2	Bushing-Tension, Loader Arm
8	106-3164	1	Pin-Pivot, Loader Arm
9	106-3140	1	Pivot Pin ASM

Ref	Part No.	Qty.	Description
10	302-5	8	Fitting-Grease
11	322-12	4	Screw-HH
12	3296-29	4	Nut-Lock, NI
14	322-5	2	Screw-HH
15	98-4871	4	Bushing-Tension
16	32148-7	2	Insert-Nut
17	107-3553-03	2	Clamp-Hose
18	86-5350	2	Bumper-Rubber
19	3269-11	4	Rivet
20	99-5105	3	Bolt-Shoulder
21	98-9907	2	Union-Bulkhead
21:1	237-30	1	O-Ring
21:2	237-79	1	O-Ring
22	104-6115	1	Coupler-Female
22:1	107-9300	1	Seal Kit
23	104-6114	1	Nipple-Connector
23:1	107-9301	1	Seal Kit
24	340-127	2	Nut-Bulkhead
25	108-4613	1	Decal
26	105-5865	1	Cap-Dust
27	105-5866	1	Plug-Dust

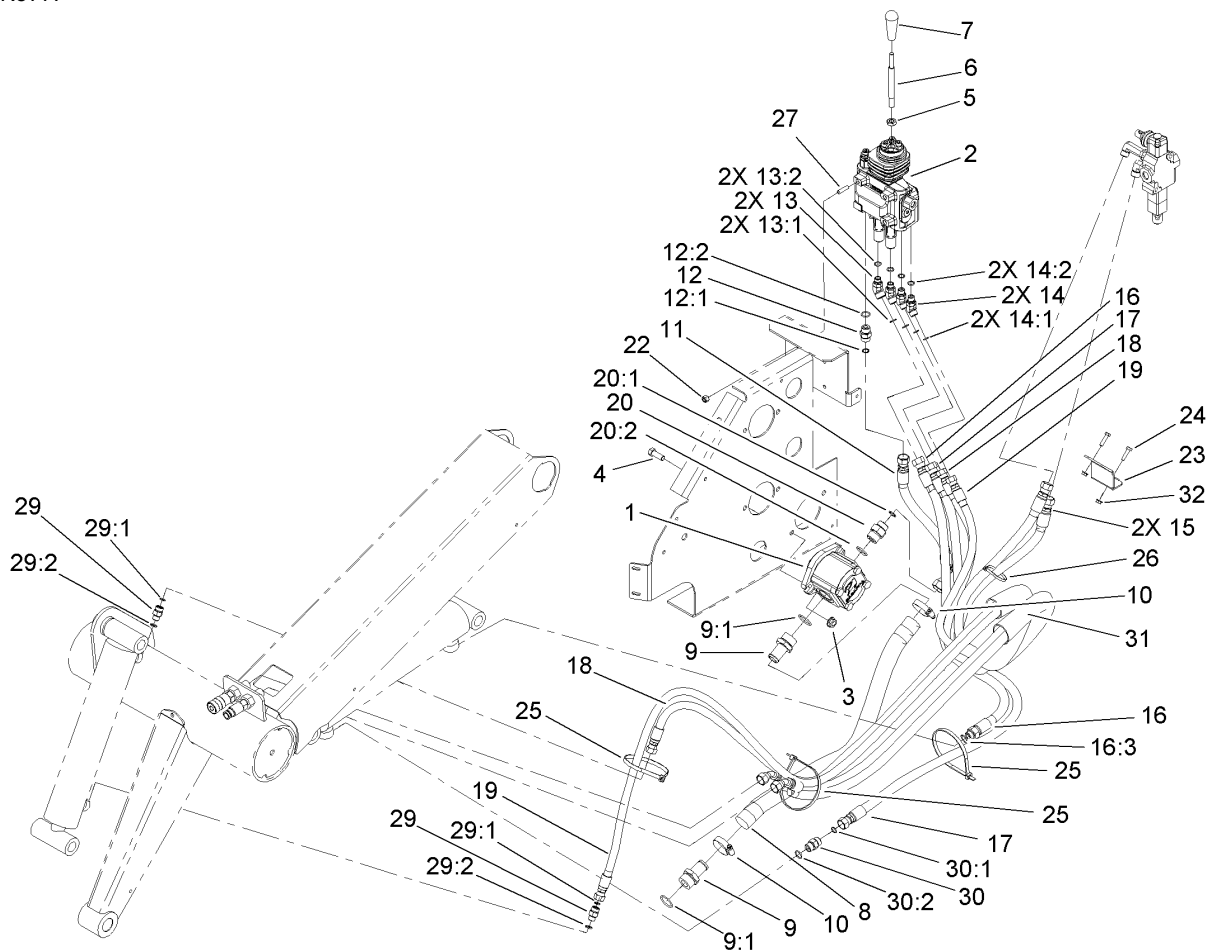

## Loader Arm Hydraulic Assembly

Ref	Part No.	Qty.	Description
1	104-8481	1	Pump-Gear
1:1	98-4700	1	Key-Square
1:2	107-3550	1	Seal Kit
2	106-9406	1	Valve-Loader
3	32128-42	2	Nut-HF
4	324-5	2	Screw-HH
5	51-2070	1	Nut
6	106-9515	1	Shaft-Handle, Lift/Tilt
7	98-0152	1	Knob-Tapered
8	106-9446	1	Hose-HYD, Suction
9	354-78	2	Connector-Hose
9:1	237-146	1	O-Ring
10	2412-111	2	Clamp
11	106-3148	1	HYD Hose ASM
12	340-4	1	Fitting-HYD, Straight
12:1	237-30	1	O-Ring
12:2	237-79	1	O-Ring
13	340-96	2	Adapter
13:1	237-30	1	O-Ring
13:2	237-42	1	O-Ring
14	340-87	2	Fitting-HYD, 45 DEG
14:1	237-22	1	O-Ring
14:2	237-42	1	O-Ring
15	106-3145	2	HYD Hose ASM

Ref	Part No.	Qty.	Description
16	106-3147	1	HYD Hose ASM
16:3	237-79	1	O-Ring
17	107-3593	1	HYD Hose ASM
18	107-3592	1	HYD Hose ASM
19	107-3591	1	HYD Hose ASM
20	340-8	1	Adapter
20:1	237-65	1	O-Ring
20:2	237-81	1	O-Ring
22	3296-29	3	Nut-Lock, NI
23	107-3595-01	1	Clamp-Hose
24	322-6	2	Screw-HH
25	3334-945	5	Tie-Cable
26	3290-379	4	Tie-Cable
27	104-0430	4	Stud
29	340-2	2	Fitting-HYD, Straight
29:1	237-22	1	O-Ring
29:2	237-42	1	O-Ring
30	340-4	1	Fitting-HYD, Straight
30:1	237-30	1	O-Ring
30:2	237-79	1	O-Ring
31	107-3589	2	Sleeve-Hose
32	32128-20	2	Nut-HF



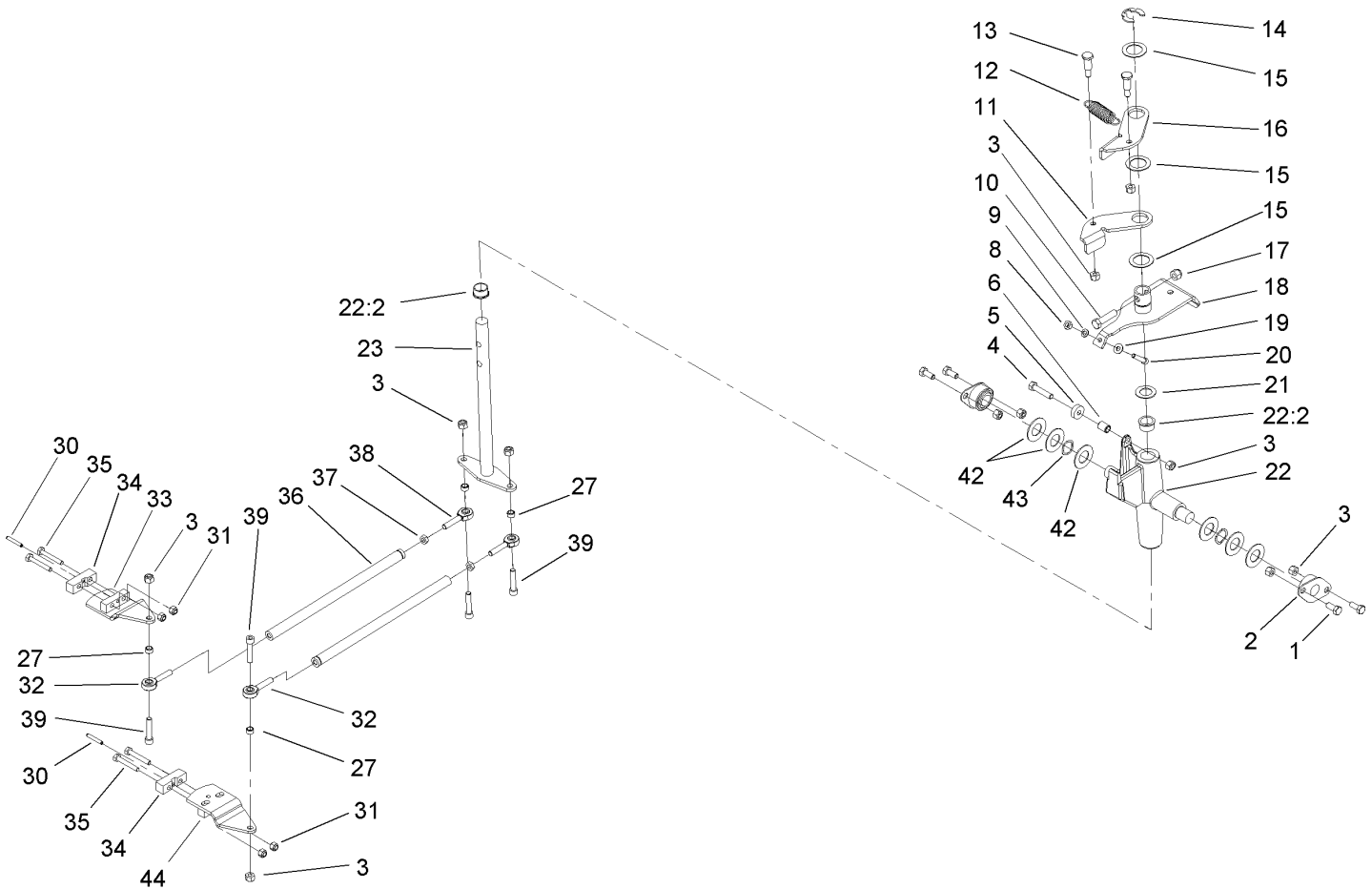

## Traction Control Assembly

Ref	Part No.	Qty.	Description
1	322-3	4	Screw-HH
2	68-2970	2	Bushing
3	3296-29	11	Nut-Lock, NI
4	322-7	1	Screw-HH
5	251-259	1	Bearing-Ball
6	88-7450	1	Spacer-Lever, Control
8	3217-5	1	Nut-Hex
9	3253-3	1	Washer-Lock
10	323-8	1	Screw-HH
11	98-8407	1	Lever-Return, RH
12	105-1210	1	Spring-Extension
13	63-2650	2	Screw-Shoulder
14	32151-91	1	Ring-Retaining
15	3256-42	3	Washer-Flat
16	98-8408	1	Lever-Return, LH
17	3296-39	1	Nut-Lock, NI
18	104-9968	1	Pivot Lever ASM
19	3256-22	1	Washer-Flat
20	3274-51	1	Screw-HSH
21	257-8	1	Washer-Thrust
22	106-5737	1	Control Support ASM
22:2	256-252	2	Bearing-Flange
23	106-5745	1	Drive Rod ASM
27	92-3133	4	Spacer-Lever, Traction

Ref	Part No.	Qty.	Description
30	32121-6	2	Pin-Roll, Slotted
31	3296-42	4	Nut-Lock, NI
32	2411-53	2	Bearing-Rod End, LH
33	104-8475	1	Pump Lever ASM
34	105-0365	2	Clamp-Traction
35	321-10	4	Screw-HH
36	105-9030	2	Rod-Linkage
37	3220-2	2	Nut-Jam
38	2411-52	2	Bearing-Rod End, RH
39	3274-83	4	Screw-HSH
42	3256-39	6	Washer-Flat
43	95-3703	2	Washer-Spring, Wave
44	105-0362	1	Pump Lever ASM

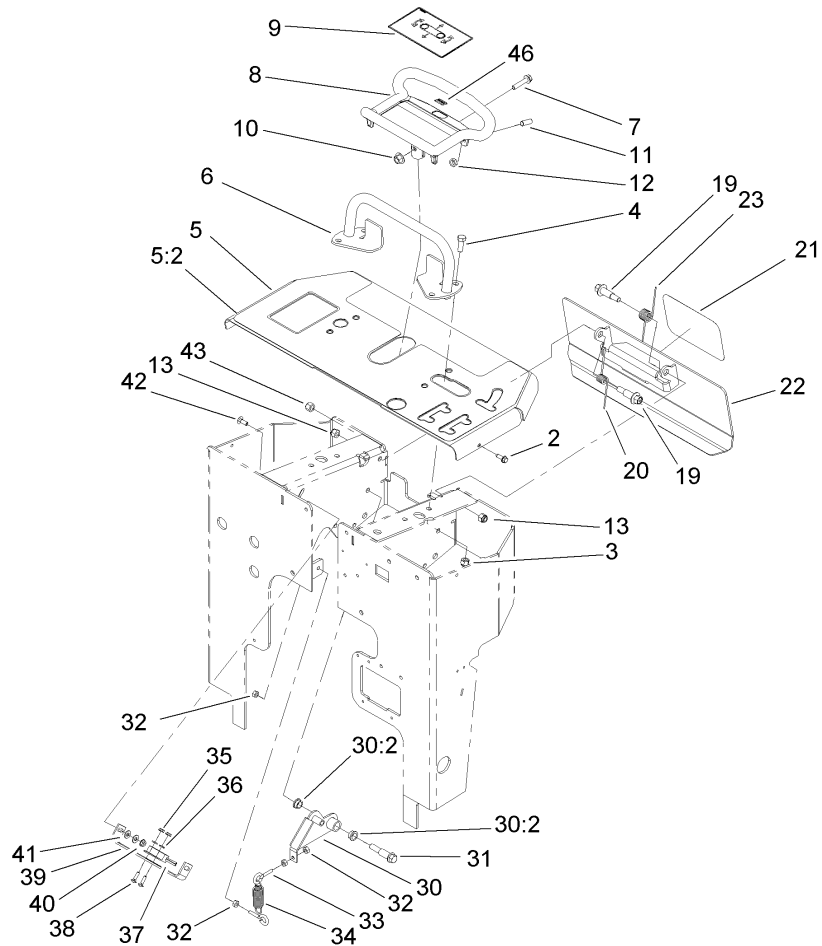

## Control Panel Assembly

Ref	Part No.	Qty.	Description	Ref	Part No.	Qty.	Description
2	32144-44	2	Screw-HWH	35	32149-7	2	Nut-Keps
3	3296-39	4	Nut-Lock, NI	36	3256-51	2	Washer-Flat
4	323-6	4	Screw-HH	37	100-1270	1	Switch-Proximity
5	106-9508	1	Control Panel ASM	38	3229-20	2	Screw-CARR
5:2	106-9450	1	Decal-Control Panel	39	100-1263	1	Plate-Switch
6	106-7715-03	1	Reference Bar ASM	40	32149-2	2	Nut-Keps
7	3234-18	1	Screw-HHF	41	3256-22	4	Washer-Flat
8	106-7614-03	1	Handle-Control	42	3229-1	2	Screw-CARR
9	106-9453	1	Decal-Traction	43	3296-6	1	Nut-Lock
10	32128-43	1	Nut-Flange	46	98-1459	1	Decal
11	3247-7	2	Screw-Set, HSH				
12	3218-3	2	Nut-Jam				
13	3296-39	2	Nut-Lock, NI				
19	62-1330	2	Bolt-Shoulder				
20	98-8424	1	Spring-Torsion, RH				
21	105-1217	1	Decal				
22	105-9031-03	1	Reverse Plate ASM				
23	98-8425	1	Spring-Torsion, LH				
30	100-4203	1	Neutral Centering Lever ASM				
30:2	256-156	2	Bushing-Flange				
31	66-0560	1	Bolt-Shoulder				
32	3217-5	4	Nut-Hex				
33	71-2870	2	Bolt-Eye				
34	105-1210	1	Spring-Extension				

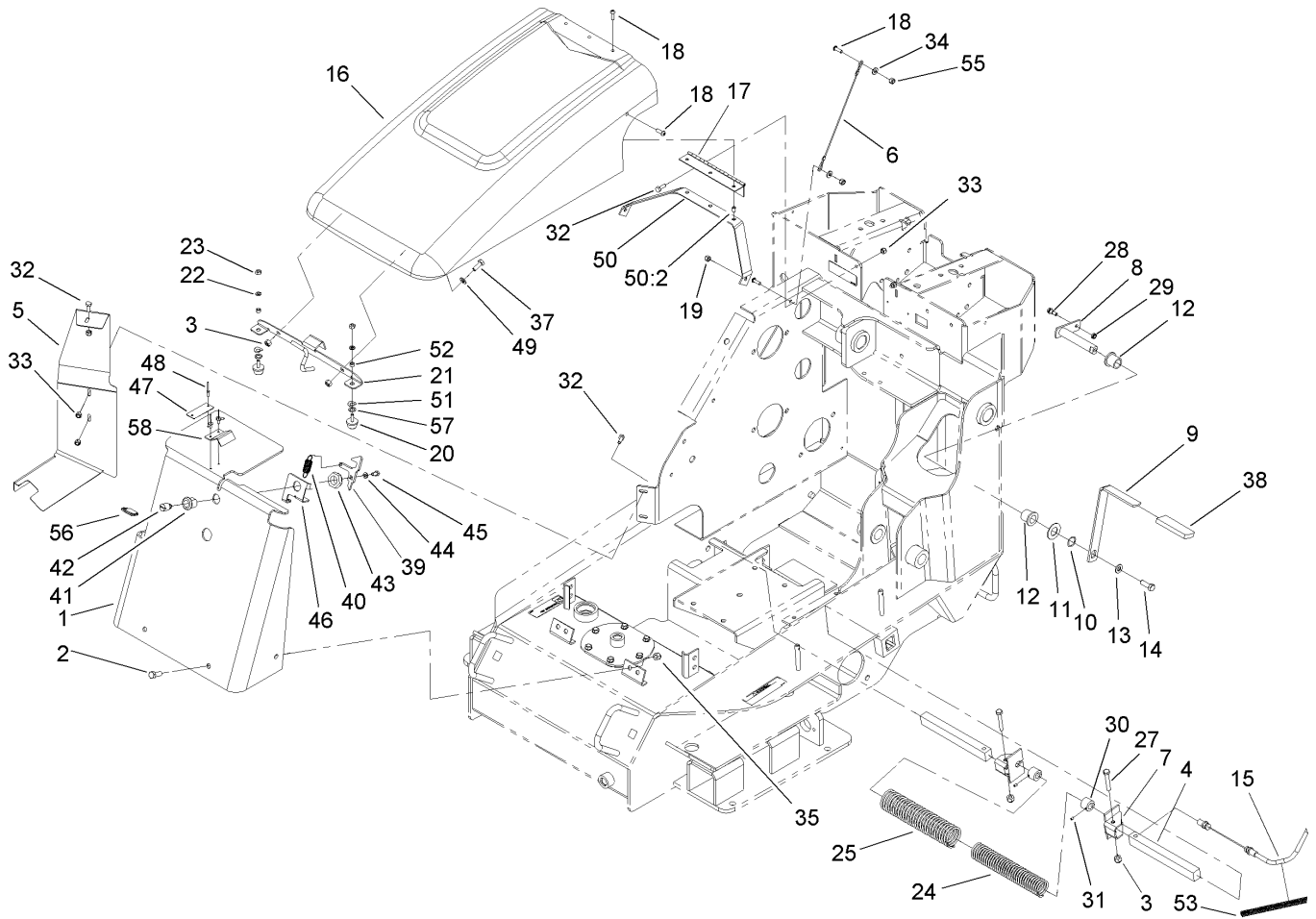

## Hood and Brake Assembly

Ref	Part No.	Qty.	Description
1	105-9038-03	1	Grille
2	323-6	4	Screw-HH
3	3296-29	5	Nut-Lock, NI
4	106-9413-03	2	Bar-Brake
5	105-9144-03	1	Deflector-Exhaust
6	106-9418	1	Lanyard
7	106-9412-03	2	Bracket-Cable
8	106-9430	1	Brake Shaft ASM
9	105-9140-03	1	Handle-Brake
10	95-3703	1	Washer-Spring, Wave
11	3256-39	1	Washer-Flat
12	256-117	2	Bushing
13	3256-24	1	Washer-Flat
14	323-18	1	Screw-HH
15	106-9433	1	Cable-Brake
16	106-9420	1	Hood ASM
17	106-9408	1	Hinge-Hood
18	106-9518	6	Screw-PRH
19	3296-42	2	Nut-Lock, NI
20	1-523420	2	Bumper
21	106-9497-03	1	Rod Latch ASM
22	3253-3	2	Washer-Lock
23	3217-5	2	Nut-Hex
24	105-7055	1	Spring-Brake

Ref	Part No.	Qty.	Description
25	105-7054	1	Spring-Brake
27	322-10	2	Screw-HH
28	42-3560	1	Bolt-Shoulder
29	3296-56	1	Nut-Lock, NI
30	100-6274	2	Tube-Guide
31	3245-20	2	Screw-HSH
32	321-4	6	Screw-HH
33	3296-42	4	Nut-Lock, NI
34	3256-78	2	Washer-Flat
35	3296-39	4	Nut-Lock, NI
37	322-4	3	Screw-HH
38	62-9130	1	Grip-Handle
39	106-5728	1	Cam-Latch
40	104-0869	1	Spring-Brake
41	106-9335	1	Housing-Latch
42	106-9336	1	Insert-Latch
43	3296-60	1	Nut-Lock, NI
44	3253-3	1	Washer-Lock
45	321-2	1	Screw-HH
46	106-5729-03	1	Bracket-Latch
47	80-9350	1	Plate-Hot Surface
48	3269-13	4	Rivet-Pop
49	3256-23	3	Washer-Flat
50	106-9519	1	Support-Hood





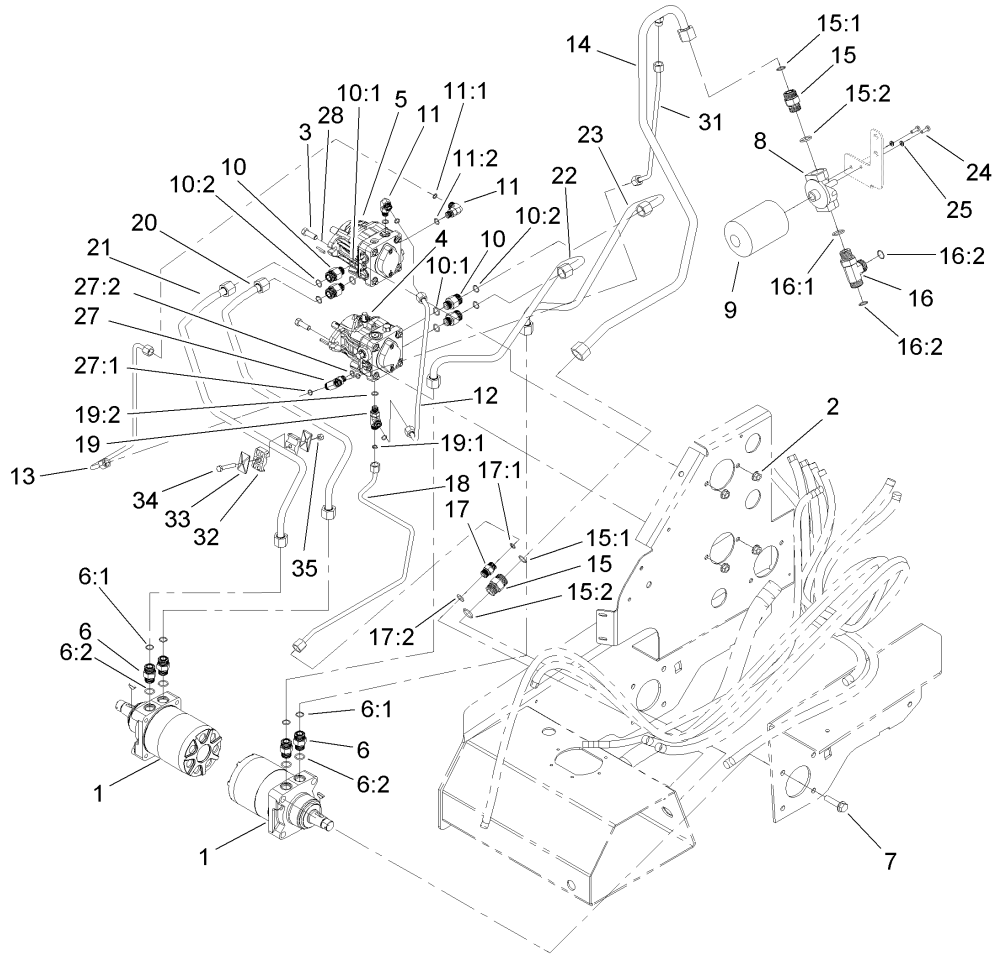

## Traction Hydraulic Assembly

Ref	Part No.	Qty.	Description
1	104-8470	2	Motor-Wheel, HYD
2	32128-42	4	Nut-HF
3	324-5	4	Screw-HH
4	106-9470	1	Pump-HYD
5	106-9471	1	Pump-HYD
6	340-7	4	Adapter
6:1	237-65	1	O-Ring
6:2	237-80	1	O-Ring
7	3234-27	8	Screw-Flange
8	92-5821	1	Filter Head ASM
9	54-0110	2	Filter-Oil, Transmission
10	340-155	4	Fitting-HYD, Straight
10:1	237-79	1	O-Ring
10:2	237-151	1	O-Ring
11	340-77	2	Fitting-HYD, 90 DEG
11:1	237-22	1	O-Ring
11:2	237-42	1	O-Ring
12	106-9445	1	HYD Tube ASM
13	106-9439	1	HYD Tube ASM
14	106-9442	1	HYD Tube ASM
15	340-9	2	Fitting-HYD, Straight
15:1	237-58	1	O-Ring
15:2	237-81	1	O-Ring
16	340-148	1	Fitting-Tee

Ref	Part No.	Qty.	Description
16:1	237-81	1	O-Ring
16:2	237-58	2	O-Ring
17	340-4	1	Fitting-HYD, Straight
17:1	237-30	1	O-Ring
17:2	237-79	1	O-Ring
18	106-9440	1	HYD Tube ASM
19	340-86	1	Fitting-HYD, Tee
19:1	237-22	2	O-Ring
19:2	237-42	1	O-Ring
20	106-9429	1	HYD Tube ASM
21	106-9428	1	HYD Tube ASM
22	106-9423	1	HYD Tube ASM
23	106-9424	1	HYD Tube ASM
24	321-4	2	Screw-HH
25	3253-3	2	Washer-Lock
27	340-94	1	Adapter
27:1	237-22	2	O-Ring
27:2	237-42	1	O-Ring
28	80-6090	2	Key-Pump
31	106-9441	1	HYD Tube ASM
32	56-7971	2	Clamp-Tube
33	69-9760	2	Coverplate
34	322-10	1	Screw-HH
35	3296-29	1	Nut-Lock, NI









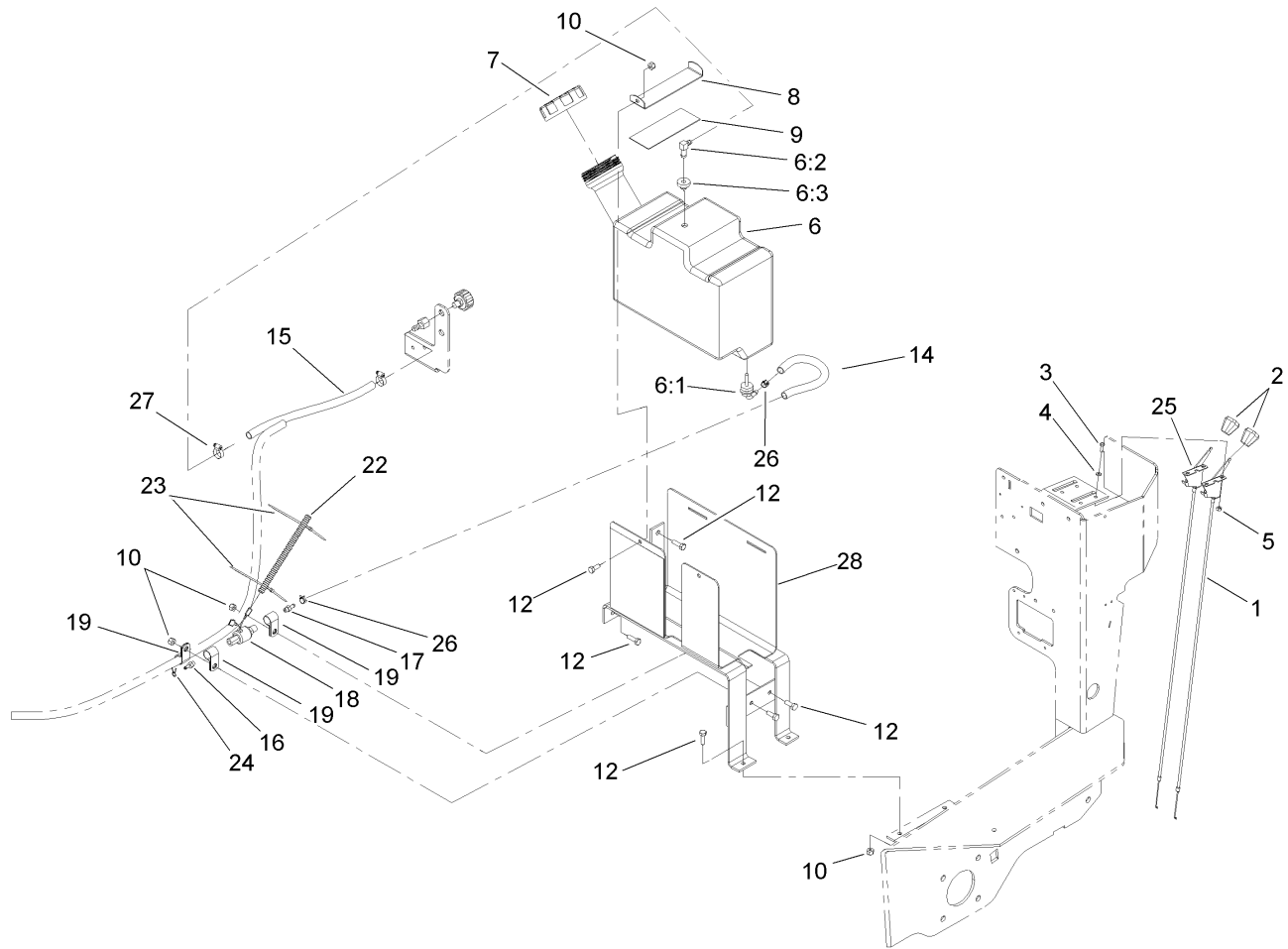

### Fuel Tank Assembly

Ref	Part No.	Qty.	Description
1	106-9435	1	Cable-Choke
2	66-0120	2	Knob
3	3290-134	4	Screw
4	3256-21	4	Washer-Flat
5	3296-2	4	Nut-Lock
6	106-9460	1	Fuel Tank ASM
6:1	103-2605	1	Fitting-Fuel, Bulkhead
6:2	100-1597	1	Fitting-90 Degree
6:3	46-6560	1	Bushing
7	95-4192	1	Unleaded Gas Cap ASM
8	106-9457-03	2	Strap-Tank
9	106-9488	2	Felt-Strap
10	3296-29	8	Nut-Lock, NI
12	322-5	8	Screw-HH
14	110-4894	1	Hose-Fuel
15	110-4110	1	Hose-Fuel
16	354-22	1	Fitting-Barb
17	304-73	1	Connector-Hose
18	106-9528	1	Valve-Shutoff, Fuel
19	2412-81	3	Clamp-R
22	106-9504	1	Cover-Brace
23	3290-381	2	Tie-Cable
24	2412-79	1	Clamp-Hose
25	106-9434	1	Cable-Throttle

Ref	Part No.	Qty.	Description
26	2412-98	3	Clamp
27	2412-36	1	Clamp-Hose
28	106-9486	1	Tank Bracket ASM

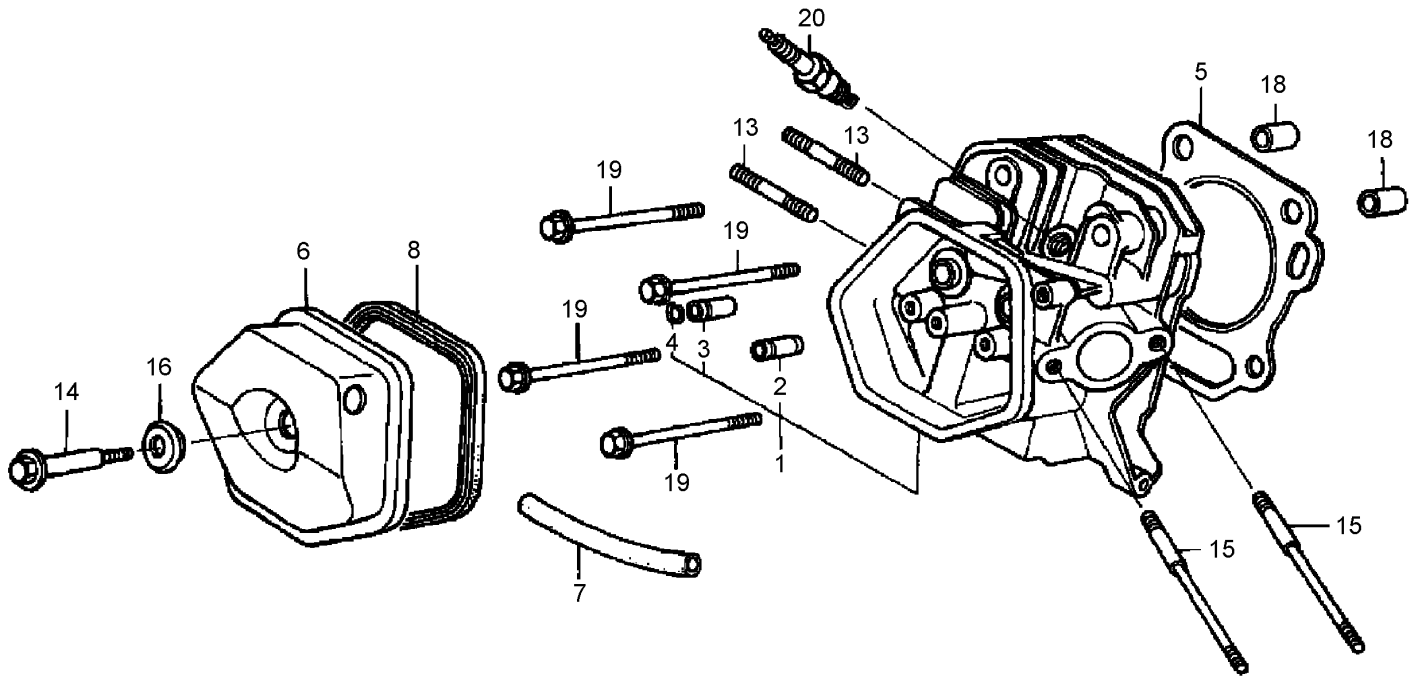

## Cylinder Head Assembly Honda GX390K1QNE2

Ref	Part No.	Qty.	Description
❶	12200-ZF6-406	1	Cylinder Head
❷	12204-ZE2-306	1	Guide-Valve
❸	12205-ZE2-305	1	Guide-Valve, Exhaust
❹	12216-ZE2-300	1	Clip-Guide, Valve
❺	12251-ZF6-W00	1	Gasket-Cylinder Head
❻	12310-ZE2-020	1	Cover-Head
❼	95005-11001-30M	1	Bulk Hose-Vacuum
❽	12391-ZE2-020	1	Gasket-Cylinder Head Cover
❿	92900-08032-0E	2	Bolt 2-Stud
⓫	90014-ZE2-000	1	Bolt-Head Cover
⓬	90042-ZE8-000	2	Bolt-Stud
⓭	90441-ZE2-010	1	Washer-Head Cover
⓮	94301-12200	2	Pin A-Dowel
⓯	95701-10080-00	4	Bolt-Flange

Ref	Part No.	Qty.	Description
⓰	98079-55846	1	Plug-Spark (Bpr5Es)
⓱	98079-55855	1	Plug-Spark (W16Epr-U)
⓲	98079-56846	1	Spark Plug (Bpr6Es) (Ngk)



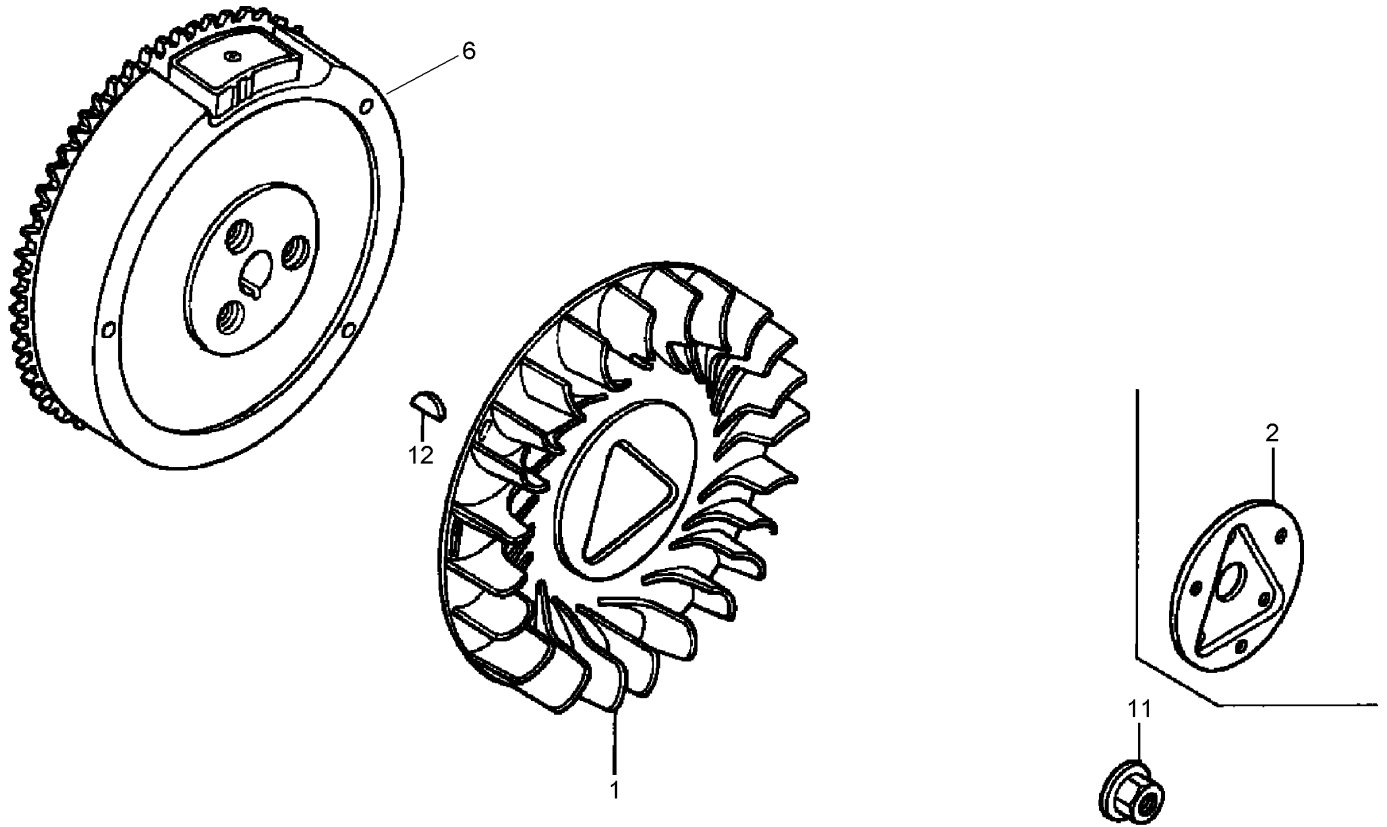

## Flywheel Assembly Honda GX390K1QNE2

Ref	Part No.	Qty.	Description				
1	19511-ZE3-000	1	Fan-Cooling				
2	19512-ZE2-000	1	Plate-Cooling Fan Setting				
6	31100-ZE3-W01	1	Flywheel (4 Pole)				
11	90201-ZE3-V00	1	Nut (16Mm)				
12	90741-ZE2-000	1	Key-Woodruff (25X18)				

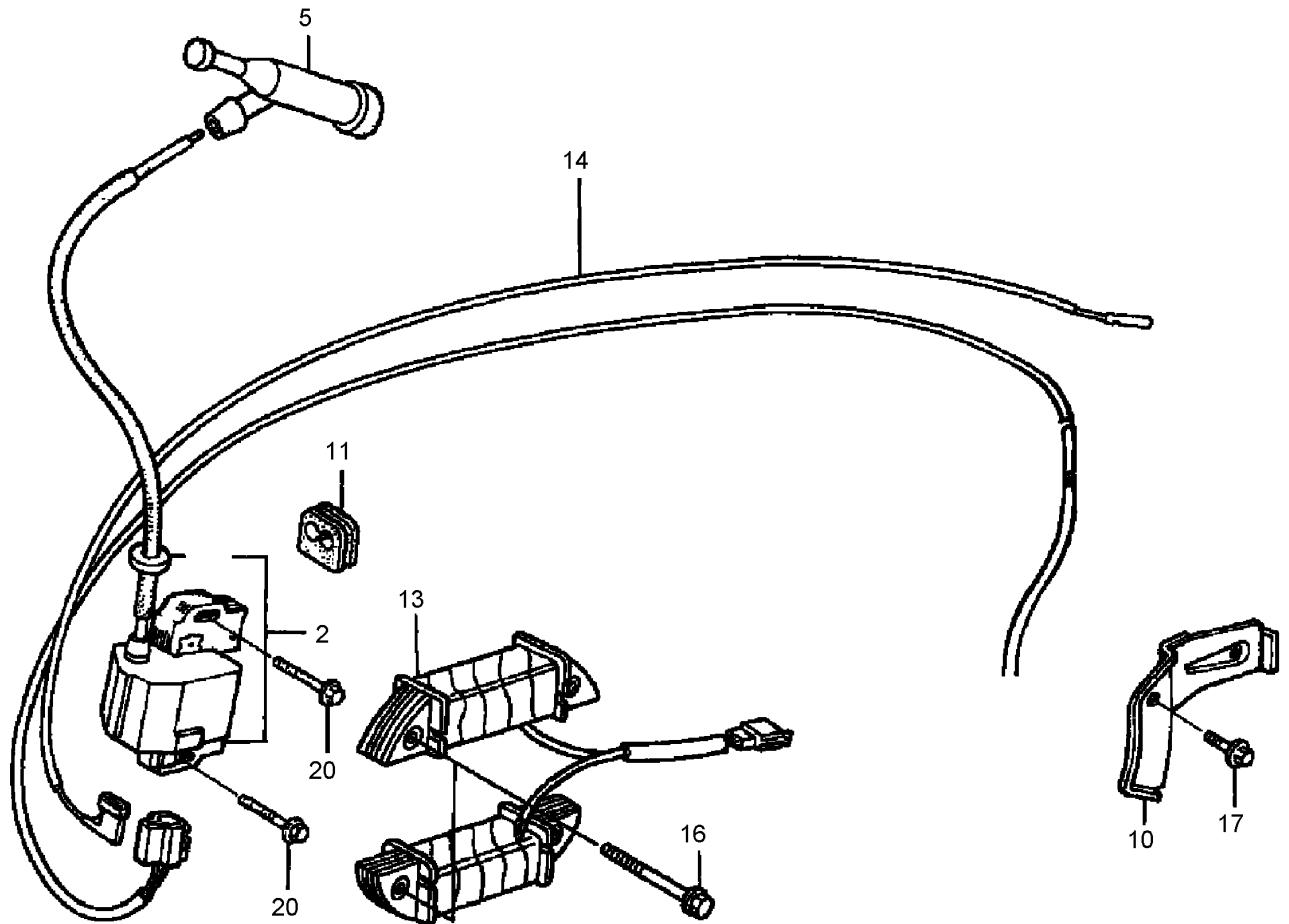

## Ignition Coil Assembly Honda GX390K1QNE2

Ref	Part No.	Qty.	Description				
2	30500-ZF6-W02	1	Coil ASM-Ignition				
5	30700-ZE1-013	1	Cap ASM- Noise Suppressor				
10	31511-ZE3-000	1	Clamp-Wire				
11	31512-ZE2-000	1	Grommet-Wire				
13	31630-ZE2-861	1	Coil ASM-Charge (10A)				
14	36101-ZE2-701	1	Wire-Stop Switch (430Mm)				
16	90012-888-000	4	Bolt-Flange (6X40)				
17	90013-883-000	1	Bolt-Flange (6X12) (Ct200)				
20	90015-883-000	2	Bolt-Flange (6X28)				

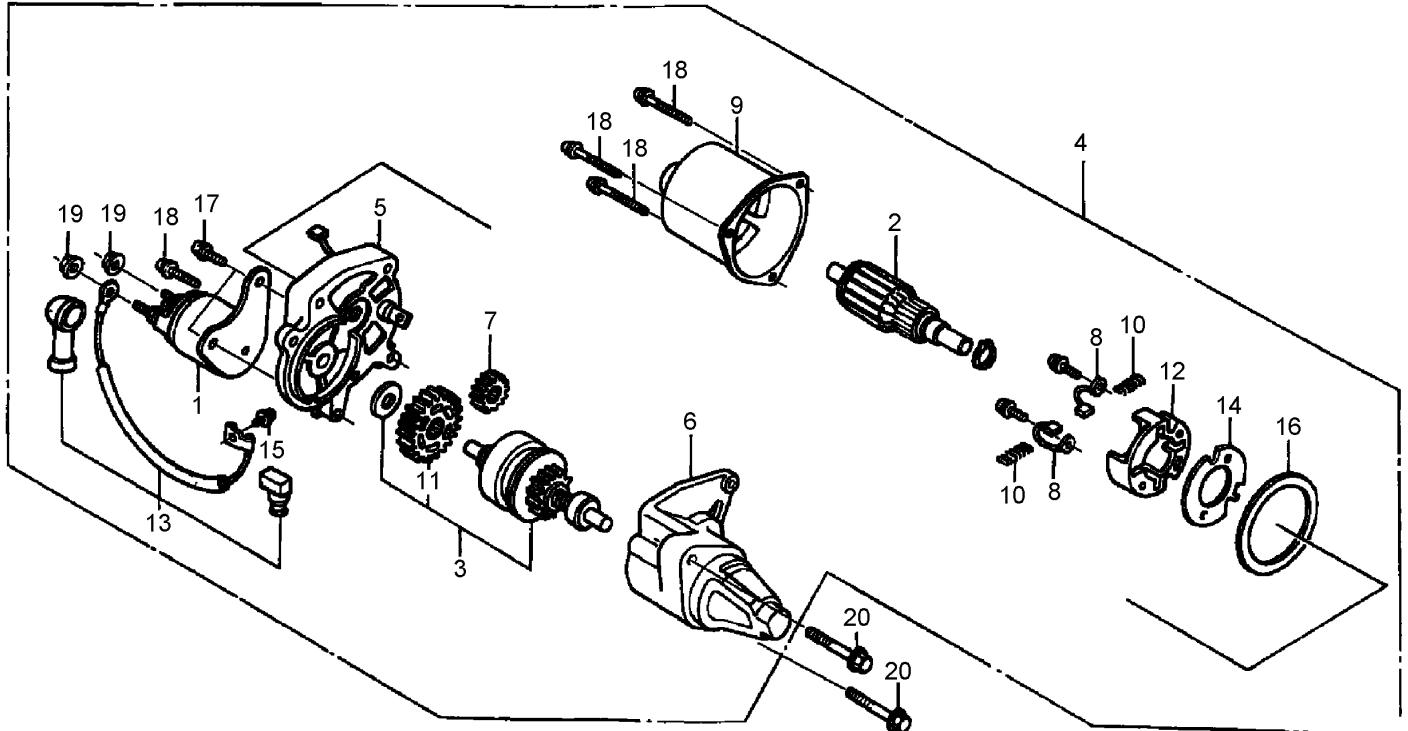

## Starter Motor Assembly Honda GX390K1QNE2

Ref	Part No.	Qty.	Description
❶	31204-ZA0-003	1	Contactorm ASM
❷	31206-ZE3-003	1	Armature
❸	31207-ZE3-003	1	Clutch-Overrunning
❹	31210-ZE3-013	1	Motor Unit-Starter
❺	31211-ZE2-003	1	Bracket-Center
❻	31212-ZE3-003	1	Bracket-Fr
❼	31213-ZE2-003	1	Gear-Drive Pinion
❽	31215-ZE2-003	2	Brush
❾	31218-ZE3-003	1	Yoke
❿	31219-ZE2-003	4	Spring-Brush Return
⓫	31222-ZE3-791	1	Gear-Reduction
⓬	31231-ZE2-003	1	Holder-Brush
⓭	31232-ZE3-003	1	Wire-Water Cover

Ref	Part No.	Qty.	Description
⓮	31233-ZE2-003	1	Insulator
⓯	90110-ZE2-003	1	Screw-Washer (4X6)
⓰	91601-ZE2-003	1	Gasket
⓱	90007-ZE2-003	2	Bolt-Washer (5X14)
⓲	93892-05032-08	4	Screw-Washer (5X3)
⓳	94070-06080	2	Nut-Washer (6Mm)
⓴	95701-08035-08	2	Bolt-Flange (8X35)

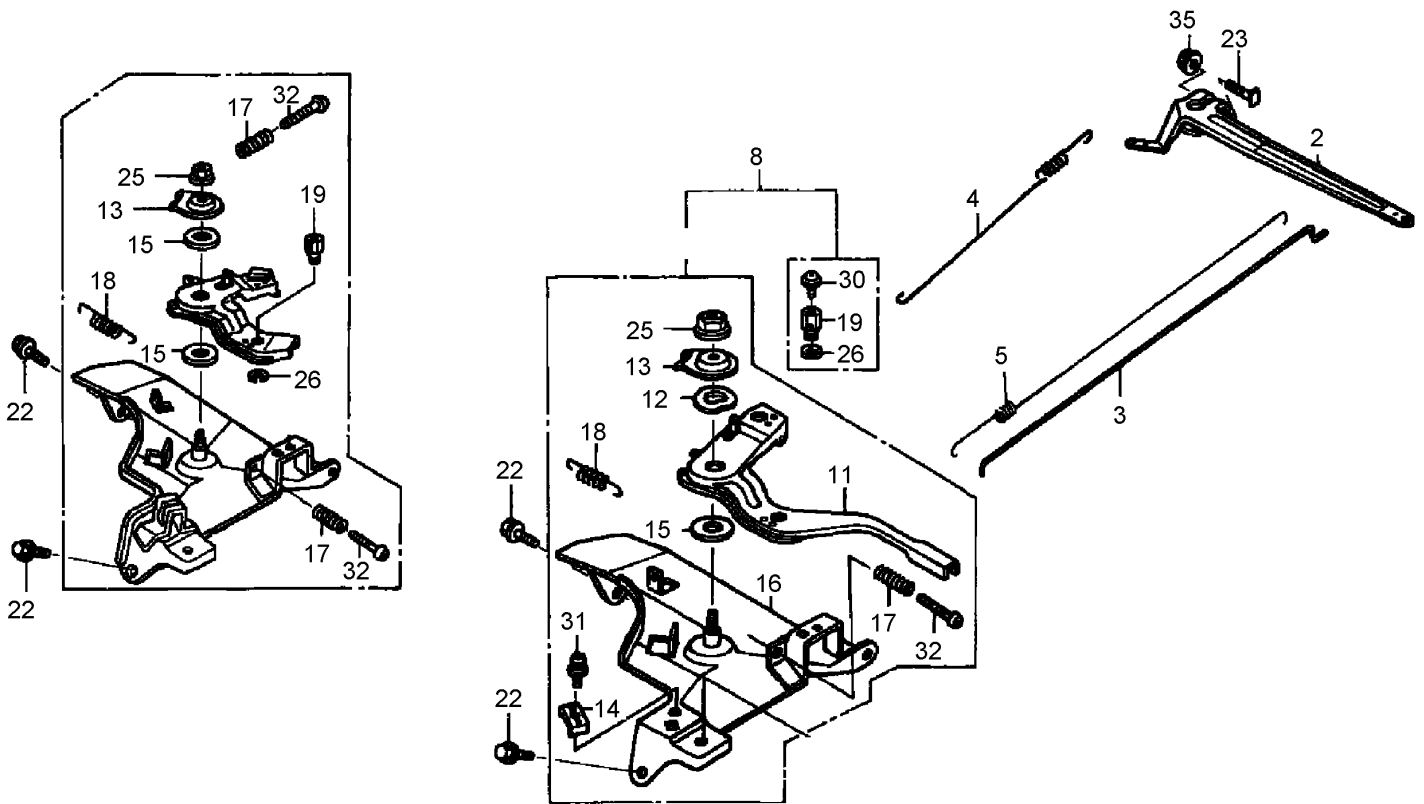

## Control Assembly Honda GX390K1QNE2

Ref	Part No.	Qty.	Description
●2	16551-ZE3-000	1	Arm-Governor
●3	16555-ZE3-000	1	Rod-Governor
●4	16561-ZE3-000	1	Spring-Governor
●5	16562-ZE3-000	1	Spring-Throttle Return
●8	16570-ZE3-W10	1	Control ASM (Remote)
●11	16571-ZE3-W00	1	Lever-Control
●12	16574-ZE1-000	1	Spring-Lever
●13	16575-ZE2-W00	1	Washer-Control Lever
●14	16576-891-000	1	Holder-Cable
●15	16578-ZE1-000	1	Spacer-Control Lever
●16	16581-ZE3-W00	1	Base-Control
●17	16584-883-300	1	Spring-Adjusting, Control
●18	16592-883-310	1	Spring-Cable Return

Ref	Part No.	Qty.	Description
●19	16594-883-010	1	Holder-Wire
●22	90013-883-000	2	Bolt-Flange (6X12) (Ct200)
●23	90015-ZE5-010	1	Bolt-Arm, Governor
●25	90114-SA0-000	1	Nut-Self-Lock (6Mm)
●26	90605-230-000	1	Circlip (5Mm)
●30	93500-04006-0H	1	Screw-Pan (4X6)
●31	93500-05016-0A	1	Screw-Pan (5X16)
●32	93893-05016-00	1	Screw-Washer (5X16)
●32	93500-05032-0A	1	Screw-Pan (5X32)
●35	94050-06000	1	Nut-Flange (6Mm)

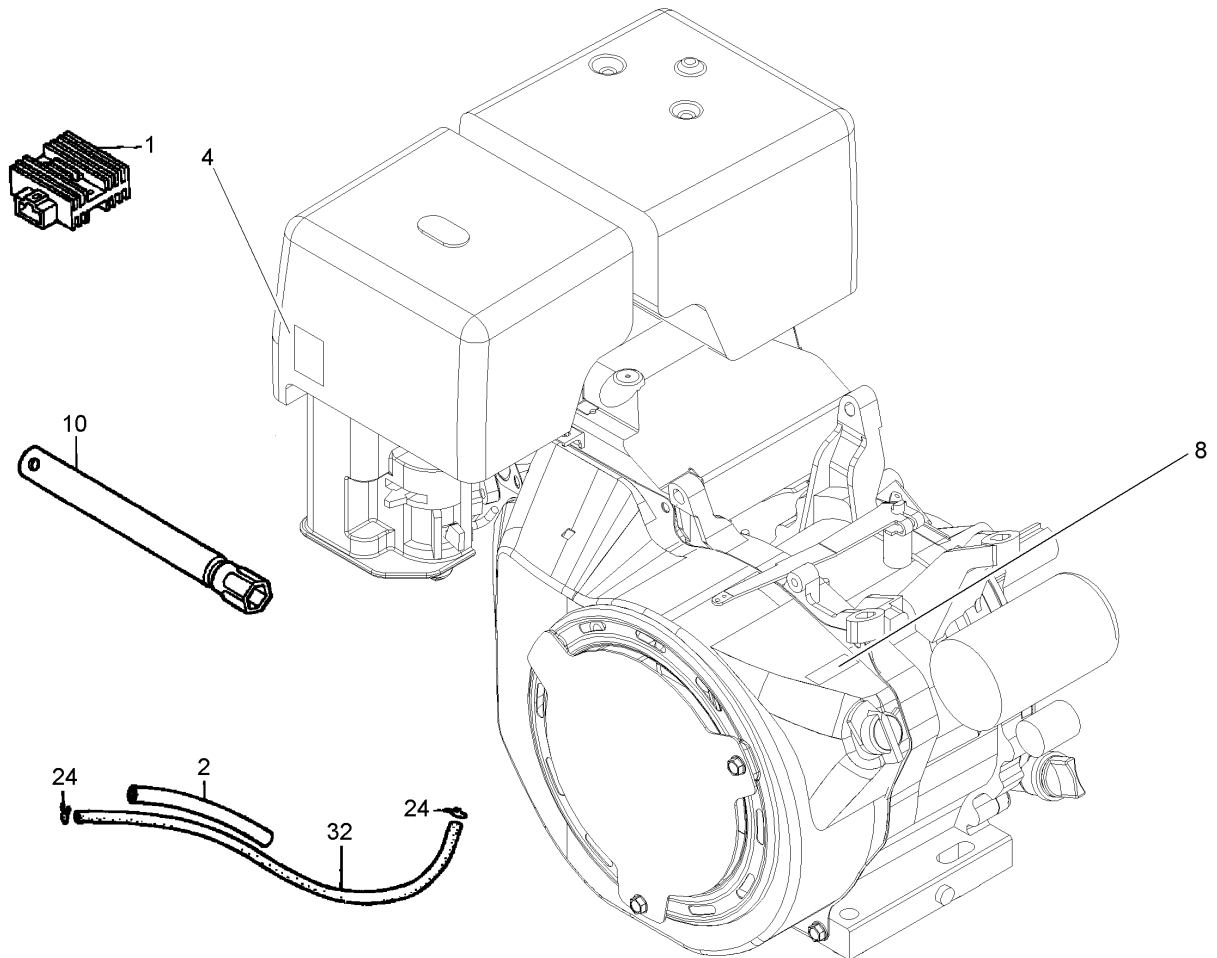

## Miscellaneous Part Assembly Honda GX390K1QNE2

Ref	Part No.	Qty.	Description				
1	31600-ZE2-861	1	Regulator Rectifier ASM				
2	16854-ZH8-000	1	Supporter-Rubber (107Mm)				
4	87528-ZE2-810	1	Mark-Choke (External)				
8	87532-ZH8-810	1	Mark, Oil Alert (E)				
10	89218-ZE1-000	1	Wrench-Spark Plug				
24	95002-02080	2	Clip-Tube (B8)				
32	95001-45003-60M	1	Hose-Fuel (4.5X3000) (4.5X235)				

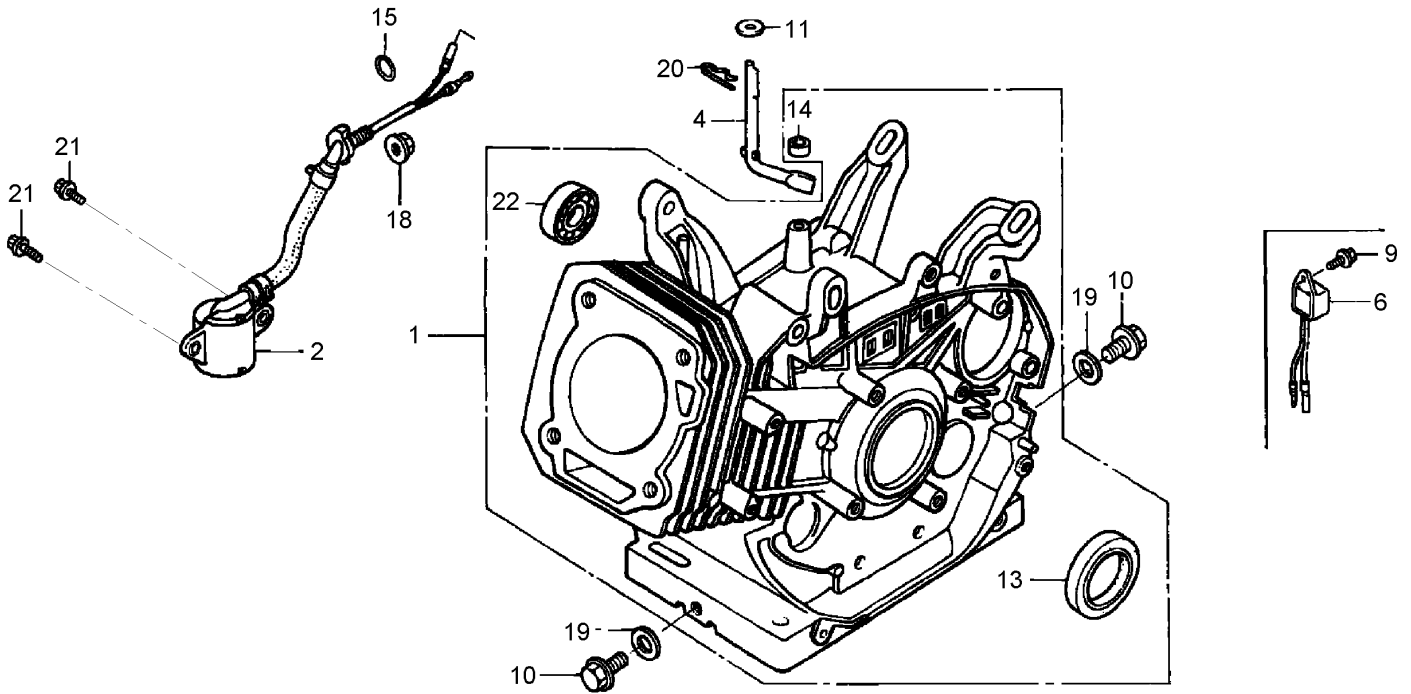

## Cylinder Barrel Assembly Honda GX390K1QNE2

Ref	Part No.	Qty.	Description
●1	12000-ZF6-425	1	Cylinder ASM
●2	15510-ZE2-043	1	Switch ASM-Oil Level
●4	16541-ZE3-010	1	Shaft-Governor Arm
●6	34150-ZH7-003	1	Alert Unit-Oil
●9	90013-883-000	1	Bolt-Flange (6X12) (Ct200)
●10	90131-883-000	2	Bolt-Drain Plug
●10	90131-896-650	2	Bolt-Drain Plug
●11	90446-KE1-000	1	Washer
●13	91201-ZE3-004	1	Seal-Oil
●14	91201-ZE9-003	1	Seal-Oil
●14	91203-952-771	1	Seal-Oil
●15	91353-671-003	1	O-Ring
●18	94050-10000	1	Nut-Flange
●19	94109-12000	2	Washer-Drain Plug
●20	94251-10000	1	Pin-Lock

Ref	Part No.	Qty.	Description
●21	95701-06012-00	2	Bolt-Flange
●22	96100-62020-00	1	Bearing-Radial Ball

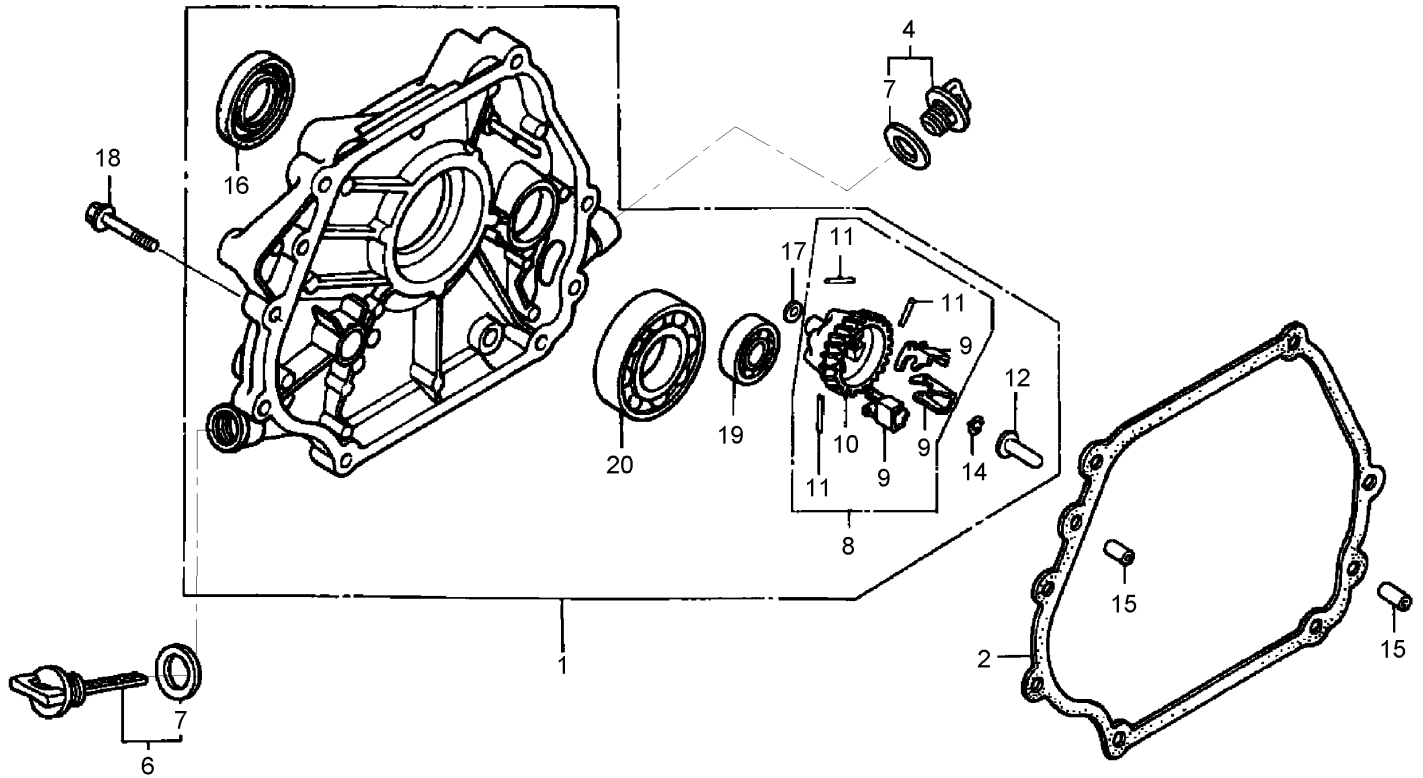

## Crankcase Cover Assembly Honda GX390K1QNE2

Ref	Part No.	Qty.	Description
❶	11300-ZE3-604	1	Cover ASM-Crankcase
❷	11381-ZE3-801	1	Gasket-Case Cover
❹	15600-ZG4-003	1	Cap ASM-Oil Filler
❻	15600-735-003	1	Cap ASM-Oil Filler
❼	15625-ZE1-003	2	Gasket-Cap, Oil Filler
❸	16510-ZE3-000	1	Governor ASM
❾	16511-ZE8-000	3	Weight-Governor
❿	16512-ZE3-000	1	Holder-Governor Weight
⓫	16513-ZE2-000	3	Pin-Weight, Governor
⓬	16531-Z0A-000	1	Slider-Governor
⓭	90602-ZE1-000	1	Clip-Holder, Governor
⓮	90701-HC4-000	2	Pin-Dowel
⓯	91201-ZE3-004	1	Seal-Oil
⓰	94101-06800	1	Washer-Plain (6Mm)

Ref	Part No.	Qty.	Description
❶❸	95701-08040-00	7	Bolt-Flange
❶❹	96100-62020-00	1	Bearing-Radial Ball
❶❷	96100-62070-00	1	Bearing-Ball, Radial

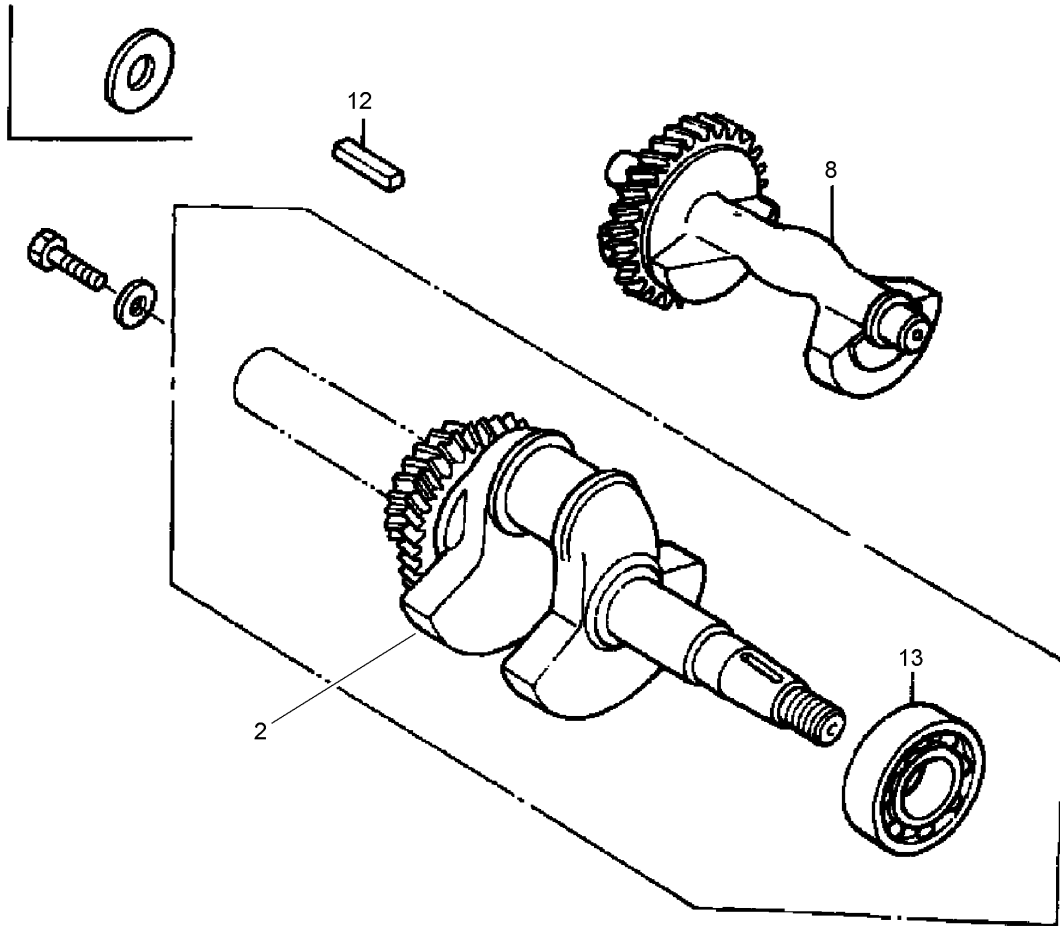

## Crankshaft Assembly Honda GX390K1QNE2

Ref	Part No.	Qty.	Description
●2	13310-ZF6-W10	1	Crankshaft (Q-Type)
●8	13351-ZE3-010	1	Weight-Balancer
●12	90745-ZE2-600	1	Key
●13	91001-ZF6-003	1	Bearing-Radial Ball (6207S)

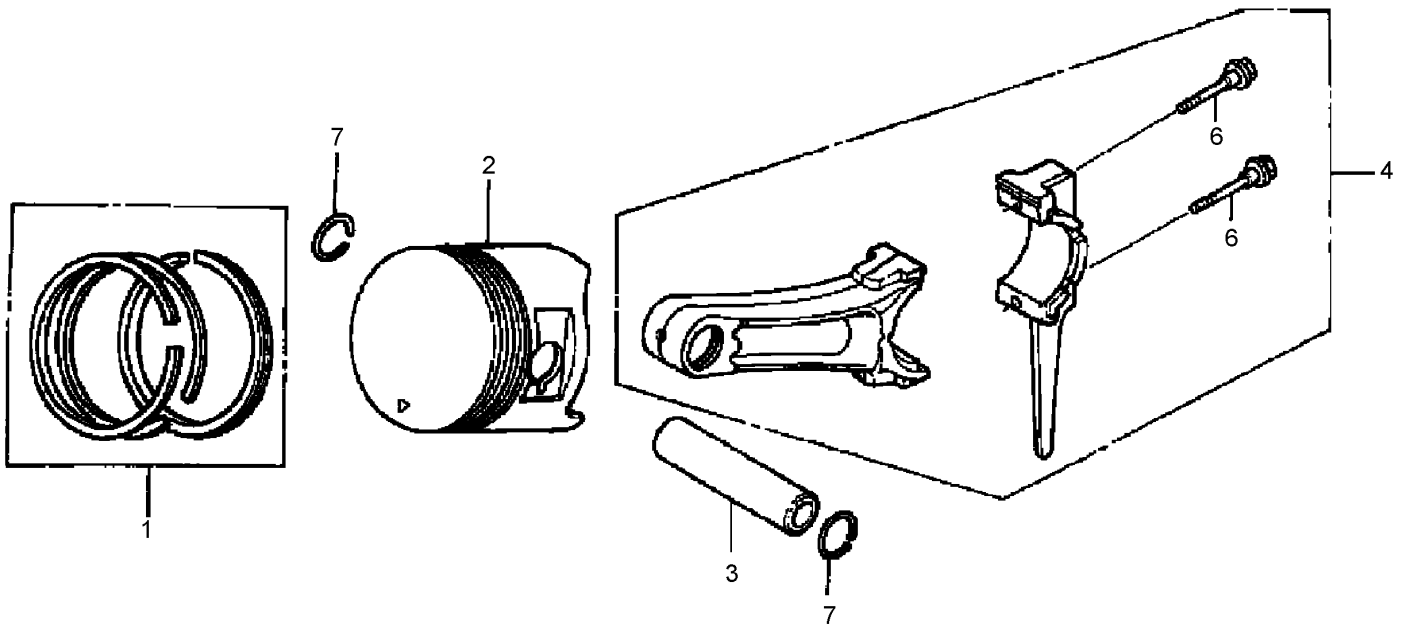
## Piston Assembly Honda GX390K1QNE2

Ref	Part No.	Qty.	Description
●1	13010-ZF6-003	1	Ring Set, Piston (STD)
●1	13011-ZF6-003	1	Ring Set, Piston (Os 0.25)
●1	13012-ZF6-003	1	Ring Set, Piston (Os 0.50)
●1	13012-ZF6-005	1	Ring Set, Piston (Os 0.50)
●1	13013-ZF6-003	1	Ring Set, Piston (0.75) (Nippon)
●2	13101-ZF6-W00	1	Piston (STD)
●2	13102-ZF6-W00	1	Piston (Os 0.25)
●2	13103-ZF6-W00	1	Piston (Os 0.50)
●2	13104-ZF6-W00	1	Piston (0.75)
●3	13111-ZF6-W00	1	Pin, Piston
●4	13200-ZE3-020	1	Rod ASM-Connecting (STD)
●4	13200-ZE3-315	1	Rod ASM-Connecting (Us 0.25)
●6	90001-ZE8-000	2	Bolt-Rod, Connecting

Ref	Part No.	Qty.	Description
●7	90601-ZE3-000	2	Clip-Pin, Piston (20Mm)

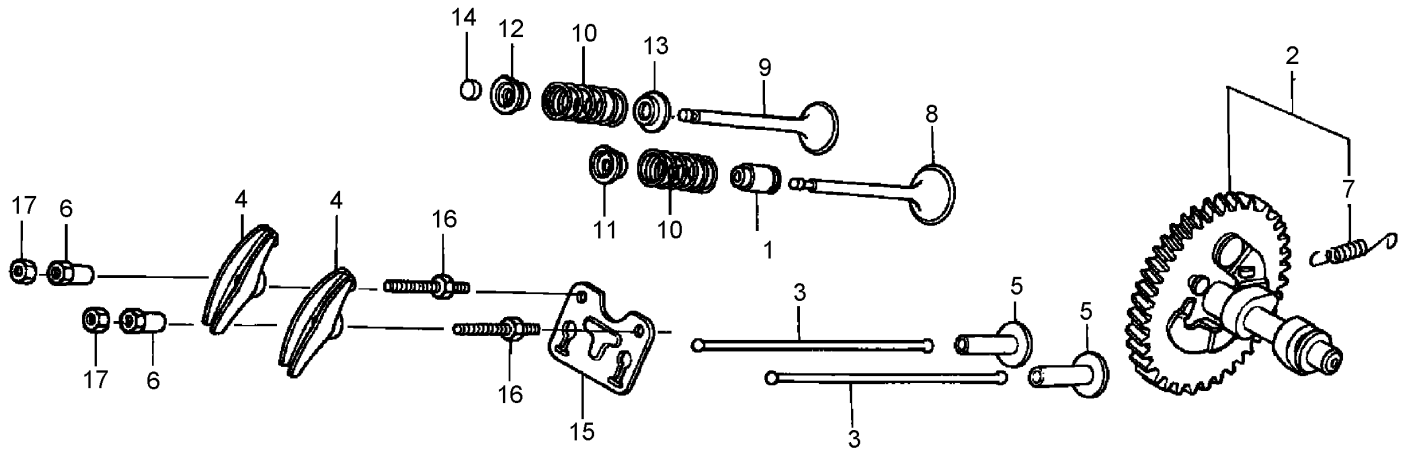

## Camshaft Assembly Honda GX390K1QNE2

Ref	Part No.	Qty.	Description
●1	12209-ZE8-003	1	Seal-Stem, Valve
●2	14100-ZF6-W01	1	Camshaft ASM
●3	14410-ZE3-013	2	Rod, Push
●4	14431-ZE2-010	2	Arm-Rocker, Valve
●5	14441-ZE2-000	2	Lifter-Valve
●6	14451-ZE1-013	2	Pivot-Arm, Rocker
●7	14568-ZE1-000	1	Spring-Return, Weight
●8	14711-ZE3-000	1	Valve-Intake
●9	14721-ZE3-000	1	Valve-Exhaust
●10	14751-ZE2-003	2	Spring-Valve
●11	14771-ZE2-000	1	Retainer-Valve, Intake
●12	14773-ZE2-000	1	Retainer-Valve, Exhaust
●13	14775-ZE2-010	1	Seat-Spring, Valve

Ref	Part No.	Qty.	Description
●14	14781-ZE2-000	1	Rotator-Valve
●15	14791-ZE2-010	1	Plate-Push Rod
●16	90012-ZE0-010	2	Bolt-Pivot (8Mm)
●17	90206-ZE1-000	2	Nut-Adj., Pivot

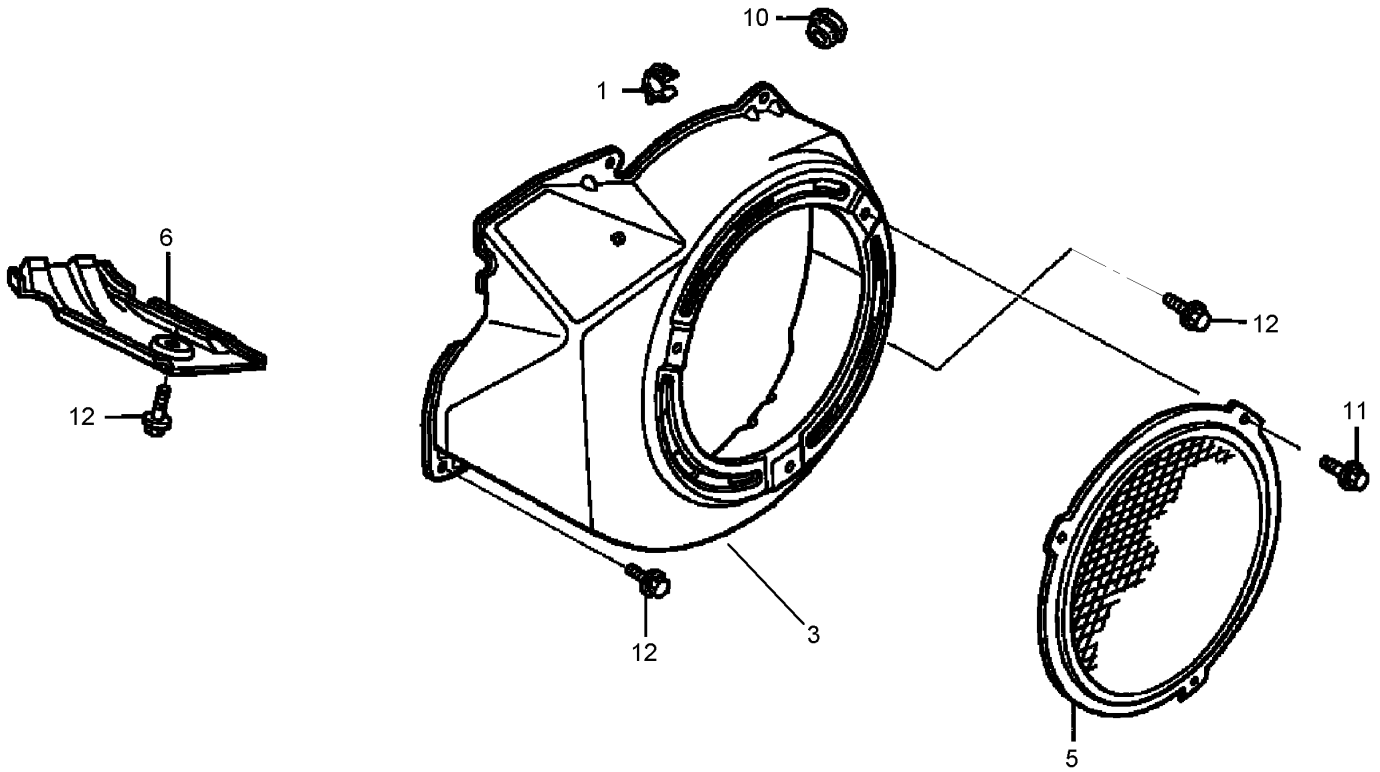

## Fan Cover Assembly Honda GX390K1QNE2

Ref	Part No.	Qty.	Description				
1	16731-ZE2-003	1	Clip-Tube				
3	19610-ZE3-010ZL	1	Cover-Fan R280 (Power)				
5	19620-ZE3-811	1	Protector-Fan Cover				
6	19631-ZE3-W00	1	Shroud				
10	81329-567-020	1	Grommet-Drain Hole				
11	90008-ZE2-003	3	Bolt-Flange				
12	90013-883-000	6	Bolt-Flange (6X12) (Cl200)				

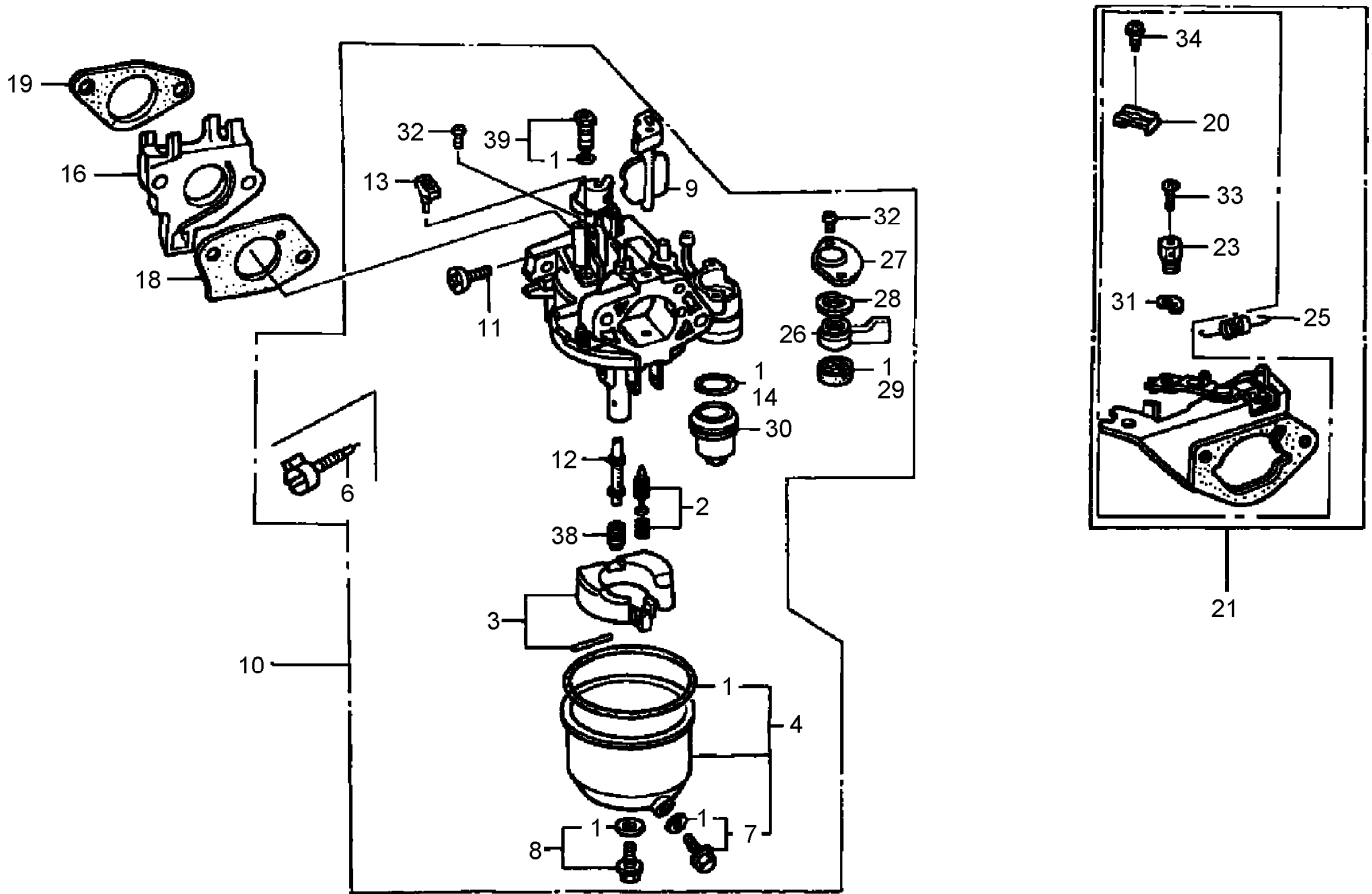

## Carburetor Assembly Honda GX390K1QNE2

Ref	Part No.	Qty.	Description
❶	16010-ZE2-812	1	Gasket Set
❷	16011-ZA0-931	1	Valve Set-Float
❸	16013-ZA0-931	1	Float Set
❹	16015-ZE8-005	1	Chamber Set-Float
❻	16016-ZH7-W01	1	Screw Set
❼	16024-ZE1-811	1	Screw Set-Drain
❽	16028-ZE0-005	1	Screw-Set
❾	16044-ZE3-W20	1	Choke Set
❿	16100-ZF6-V01	1	Carburetor ASM (Be85B)
⓫	16124-ZE0-005	1	Screw-Stop, Throttle
⓬	16166-ZF6-V00	1	Nozzle-Main
⓭	16172-ZE3-W10	1	Collar-Set
⓮	16173-001-004	1	Gasket-Fuel Strainer

Ref	Part No.	Qty.	Description
⓯	16211-ZF6-000	1	Insulator-Carburetor
⓰	16221-ZF6-800	1	Gasket-Carburetor
⓱	16223-ZE3-W00	1	Gasket-Insulator
⓲	16576-891-000	1	Holder-Cable
⓳	16590-ZE2-812	1	Stay ASM-Choke (Remote)
⓴	16594-883-010	1	Holder-Wire
⓵	16615-ZE2-810	1	Spring-Return
⓶	16953-ZE1-812	1	Lever-Valve
⓷	16954-ZE1-812	1	Plate-Setting, Lever
⓸	16956-ZE1-811	1	Spring-Lever, Valve
⓹	16957-ZE1-812	1	Gasket-Valve
⓺	16967-ZE0-811	1	Cup-Fuel Strainer
⓻	90605-230-000	1	Circlip (5Mm)





# Attachments and Accessories

For 22330 - TX 413 Compact Utility Loader

Product Name	Model/Part
Track Kit .....	104-6106
Road Wheel Kit .....	106-7620
Road Wheel Kit (5-Pack) .....	106-7627
Track-Aggressive Tread .....	108-5640
Alignment Tool .....	110-0069

# NOTES

# NOTES

