



Sand Pro[®] 5020

Model No. 08886—Serial No. 26000001 and Up

Operator's Manual



Warning



The engine exhaust from this product contains chemicals known to the State of California to cause cancer, birth defects, or other reproductive harm.

Important The engine in this product is not equipped with a spark arrester muffler. It is a violation of California Public Resource Code Section 4442 to use or operate this engine on any forest-covered, brush-covered, or grass-covered land as defined in CPRC 4126. Other states or federal areas may have similar laws.

This spark ignition system complies with Canadian ICES-002.

Ce système d'allumage par étincelle de véhicule est conforme à la norme NMB-002 du Canada.

The enclosed Engine Owner's Manual is supplied for information regarding The U.S. Environmental Protection Agency (EPA) and the California Emission Control Regulation of emission systems, maintenance and warranty.

Keep this engine Owner's Manual with your unit. Should this engine Owner's Manual become damaged or illegible, replace immediately. Replacements may be ordered through the engine manufacturer.

Contents

	Page
Contents	2
Introduction	3
Safety	3
Before Operating	3
While Operating	3
Maintenance	4
Sound Pressure Level	4
Sound Power Level	5
Vibration Level	5
Safety and Instruction Decals	5
Specifications	8
General Specifications	8
Measurements	8
Optional Equipment	9
Setup	9
Loose Parts	9
Installing the Wheels	10
Installing the Steering Wheel	10
Removing The Battery	10
Activating and Charging the Battery	11
Installing the Battery	11

Installing the Decals	11
Before Operating	12
Checking the Crankcase Oil	12
Filling the Fuel Tank	12
Checking the Hydraulic System	13
Checking the Tire Pressure	14
Operation	14
Using the Controls	14
Fuel Shutoff Valve	16
Starting and Stopping the Engine	16
Checking the Interlock System Operation	17
Towing the Machine	17
Break-In Period	17
Operating Characteristics	17
Inspecting and Cleaning the Machine	17
Maintenance	18
Recommended Maintenance Schedule	18
Daily Maintenance Checklist	19
Lubricating the Machine	20
Changing the Engine Oil and Filter	20
Servicing the Engine Air Cleaner	21
General Air Cleaner Maintenance	21
Servicing the Remote Air Cleaner	21
Adjusting the Throttle Control	22
Adjusting the Choke Control	22
Replacing the Spark Plugs	22
Cleaning the Cylinder Head Fins	23
Changing the Hydraulic System Oil and Filter ...	23
Checking the Hydraulic Lines and Hoses	24
Charging the Hydraulic System	24
Adjusting the Steering Chain	25
Replacing the Fuel Filter	25
Adjusting the Traction Drive for Neutral	25
Adjusting the Traction Interlock Switch	26
Adjusting the Pedal for Forward	26
Adjusting Steering Wheel Tilt Lever	26
Adjusting the Parking Brake	27
Adjusting Lift Lever	27
Storing the Battery	28
Caring for the Battery	28
Electrical Schematic	29
Hydraulic Schematic	30
The Toro General Commercial Products Warranty ...	32

Introduction

Read this manual carefully to learn how to operate and maintain your product properly. The information in this manual can help you and others avoid injury and product damage. Although Toro designs and produces safe products, you are responsible for operating the product properly and safely.

Whenever you need service, genuine Toro parts, or additional information, contact an Authorized Service Dealer or Toro Customer Service and have the model and serial numbers of your product ready. These numbers are stamped into a plate located on the left frame rail.

Write the product model and serial numbers in the space below:

Model No. _____
Serial No. _____

This manual identifies potential hazards and has special safety messages that help you and others avoid personal injury and even death. **Danger**, **Warning**, and **Caution** are signal words used to identify the level of hazard. However, regardless of the hazard, be extremely careful.

Danger signals an extreme hazard that *will* cause serious injury or death if you do not follow the recommended precautions.

Warning signals a hazard that *may* cause serious injury or death if you do not follow the recommended precautions.

Caution signals a hazard that may cause minor or moderate injury if you do not follow the recommended precautions.

This manual uses two other words to highlight information.

Important calls attention to special mechanical information and **Note**: emphasizes general information worthy of special attention.

Safety

This machine was designed and tested to offer safe service when operated and maintained properly. Although hazard control and accident prevention partially are dependent upon the design and configuration of the machine, these factors are also dependent upon the awareness, concern, and proper training of the personnel involved in the operation, transport, maintenance, and storage of the machine. Improper use or maintenance of the machine can result in injury or death. To reduce the potential for injury or death, comply with the following safety instructions.

Before Operating

- Operate the machine only after reading and understanding the contents of this manual.
- Never allow children to operate the machine or adults to operate it without proper instructions.
- Become familiar with the controls and know how to stop the engine quickly.
- Keep all shields, safety devices, and decals in place. If a shield, safety device, or decal is malfunctioning, illegible, or damaged, repair or replace it before operating the machine.
- Always wear substantial shoes. Do not operate machine while wearing sandals, tennis shoes, or sneakers. Do not wear loose fitting clothing which could get caught in moving parts and cause personal injury.
- Wearing safety glasses, safety shoes, long pants, and a hard hat is advisable and required by some local safety and insurance regulations.
- Ensure that the traction interlock switch is adjusted correctly so that the engine cannot be started unless the traction pedal is released and in the neutral position.
- Keep everyone, especially children and pets, away from the areas of operation.
- Since gasoline is highly flammable, handle it carefully.
 - Use an approved gasoline container.
 - Do not remove the cap from the fuel tank when engine is hot or running.
 - Do not smoke while handling gasoline.
 - Fill the fuel tank outdoors and to about 1 in. (25 mm) below top of tank (bottom of the filler neck). Do not overfill.
 - Wipe up any spilled gasoline.
- Check the safety interlock system daily for proper operation. If the switch should malfunction, replace the switch before operating machine. After every two years, replace the interlock switch in the safety system, whether it is working properly or not.

While Operating

- Exhaust fumes are hazardous and could be deadly, so do not run the engine in a confined area without adequate ventilation.
- Sit on seat when operating the machine. Never carry passengers.

- When starting the engine:
 - Make sure that the traction pedal is released.
 - After the engine is started, keep your foot off of the traction pedal. The machine must not move. If movement is evident, the neutral return bracket is adjusted incorrectly; therefore, shut the engine off and adjust the bracket so that the machine does not move when in the neutral position. If the engine does not start, check the interlock switch for proper adjustment.
- Using the machine demands attention. To prevent tipping or loss of control:
 - Use care when entering and leaving sand traps. Use extreme caution around ditches, creeks, or other hazards.
 - Watch for holes or other hidden hazards.
 - Use caution when operating the machine on a steep slope. Reduce your speed when making sharp turns or when turning on hillsides.
 - Avoid sudden stops and starts. Do not go from reverse to full forward without first coming to a complete stop.
 - Before backing up, look to the rear and ensure that no one is behind the machine.
 - Watch out for traffic when near of crossing roads. Always yield the right of way.
- If the optional Draw Bar, Part No. 92-2330, is installed on the machine, the vertical load on the hitch should not exceed 200 lb. (91 kg).
- Do not touch the engine, muffler, or exhaust pipe while the engine is running or soon after it has stopped because these areas are hot enough to cause burns.
- If the machine ever vibrates abnormally, stop immediately, turn the engine off, wait for all motion to stop, and inspect for damage. Repair all damage before commencing operation.
- Before getting off of the seat:
 - Engage the parking brake and lower the attachment. Take precautions to prevent accidental starts, rolling away, etc.
 - Shut the engine off and wait for all movement to stop.
- Whenever the machine is left unattended, be sure that the engine is stopped, the parking brake is engaged, the implement is lowered, and the key is removed from the ignition.

Maintenance

- Before servicing or making adjustments to the machine, stop the engine and pull the spark plug wire off of the spark plug to prevent accidental starting of the engine.
- Make sure that all hydraulic line connectors are tight, and all hydraulic hoses and lines are in good condition before applying pressure to the system.
- Keep your body and hands away from pin hole leaks or nozzles that eject hydraulic fluid under high pressure. Use paper or cardboard, not your hands, to search for leaks. Hydraulic fluid escaping under pressure can have sufficient force to penetrate skin and do serious damage. If fluid is injected into the skin it must be surgically removed within a few hours by a doctor familiar with this form of injury or gangrene may result.
- Before disconnecting or performing any work on the hydraulic system, all pressure in the system must be relieved by stopping the engine, engaging the parking brake, and lowering the attachments to the ground.
- To make sure that the entire machine is in good condition, keep all nuts, bolts, and screws properly tightened.
- If major repairs are ever needed or assistance is required, contact an Authorized Toro Distributor.
- To reduce potential fire hazard, keep the engine area free of excessive grease, grass, leaves, and accumulation of dirt.
- If the engine must be running to perform a maintenance adjustment, keep hands, feet, clothing, and any parts of the body away from the engine and any moving parts. Keep everyone away.
- Do not overspeed engine by changing governor settings. Maximum engine speed is 3200 RPM. To ensure safety and accuracy, have an Authorized Toro Distributor check the maximum engine speed with a tachometer.
- The engine must be shut off before checking the oil or adding oil to the crankcase.
- To be sure of optimum performance and safety, always purchase genuine Toro replacement parts and accessories. Replacement parts and accessories made by other manufacturers could be dangerous. Such use could void the product warranty.

Sound Pressure Level

This unit has an equivalent continuous A-weighted sound pressure at the operator ear of: 84 dB(A), based on measurements of identical machines per Directive 98/37/EC and amendments.

Sound Power Level

This unit has a guaranteed sound power level of: 100 dBA/1 pW, based on measurements of identical machines per Directive 2000/14/EC and amendments.

Whole Body

This unit does not exceed a vibration level of 0.5 m/s² at the posterior based on measurements of identical machines per ISO 2631 procedures.

Vibration Level

Hand-Arm

This unit does not exceed a vibration level of 2.5 m/s², at the hands based on measurements of identical machines per ISO 5349 procedures.

Safety and Instruction Decals



Safety decals and instructions are easily visible to the operator and are located near any area of potential danger. Replace any decal that is damaged or lost.

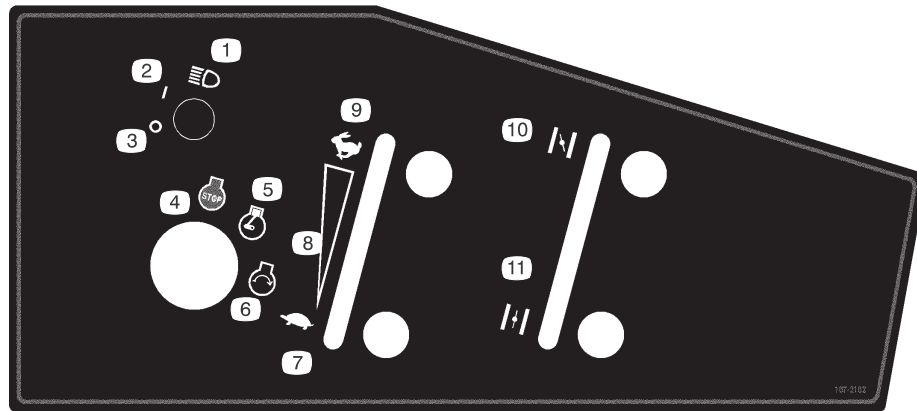

107-2162

- | | | | |
|---------------|-----------------|--------------------------------|------------------|
| 1. Headlights | 4. Engine—stop | 7. Fast | 10. Choke—closed |
| 2. On | 5. Engine—run | 8. Continuous variable setting | 11. Choke—open |
| 3. Off | 6. Engine—start | 9. Slow | |

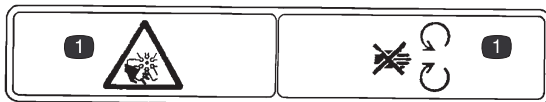

93-7272

1. Fan blades can cause injury—stay away from moving parts.

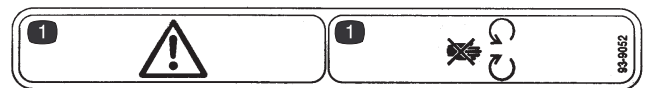

93-9052

1. Warning—stay away from moving parts.

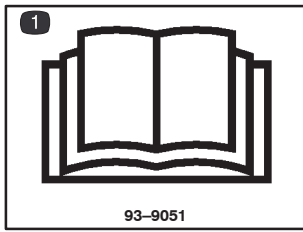

93-9051

1. Read the operator's manual.

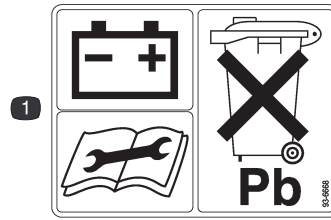

93-6668

1. The battery contains lead. Do not throw the battery in the garbage. Read the operator's manual before performing maintenance.

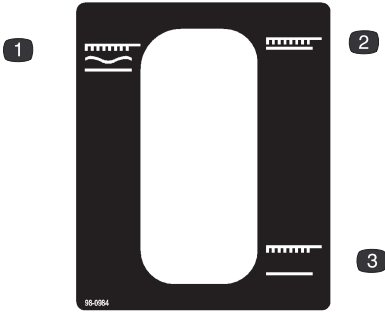

98-0984

1. Implement float position
2. Implement lower position
3. Implement raise position

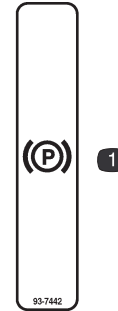

93-7442

1. Parking brake.

SAND PRO 5020
QUICK REFERENCE AID
CHECK / SERVICE (DAILY)

1. OIL LEVEL, ENGINE
2. OIL LEVEL, HYDRAULIC TANK
3. NEUTRAL INTERLOCK SWITCH
4. AIR FILTERS
5. ENGINE COOLING FINS
6. TIRE PRESSURE (4 - 6 psi / 3-.4 bar)
7. WHEEL NUT TORQUE (45-55 FT.-LBS. / 61-75 N*m)
8. BATTERY
9. LUBRICATION
10. FUEL - GAS ONLY

SEE OPERATOR'S MANUAL FOR INITIAL CHANGE	FLUID TYPE	CAPACITY	CHANGE INTERVALS		FILTER PART NO.
			FLUID	FILTER	
ENGINE OIL	SAE 30 SJ	* 1 3/4 QTS	25 HRS.	100 HRS.	++492932 (A)
HYDRAULIC OIL	Mobil DTE 15M	* 3 GAL.	400 HRS.	400 HRS.	23-9740 (B)
AIR CLEANER (ON ENGINE)				**400 HRS.	++394018 (C)
AIR CLEANER (ON FENDER)	UNLEADED GAS			**400 HRS.	93-2195 (D)
FUEL TANK / FILTER		5 1/2 GAL.		+800 HRS.	94-2690 (E)

* INCLUDING FILTER ** CLEAN EVERY 100 HRS. + OR YEARLY, WHICH EVER IS LESS ++ BRIGGS & STRATTON PART NO.

98-0977

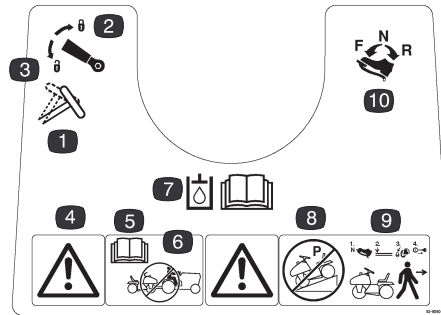

93-9050

1. Tilt steering wheel.
2. Steering wheel lock.
3. Steering wheel unlock.
4. Warning
5. Read operator's manual.
6. Do not tow machine
7. Refer to operator's manual for hydraulic oil specifications.
8. Do not park machine on a slope.
9. Before leaving the operator's position, put the traction control pedal in neutral, turn the engine off, and remove the ignition key.
10. Traction pedal—forward, neutral and reverse.

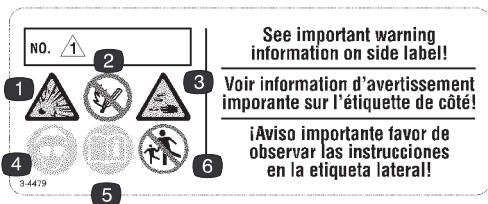

104-4163

- | | |
|--|--|
| 1. Explosion hazard | 4. Wear eye protection |
| 2. No fire, open flames, or smoking. | 5. Read the <i>Operator's Manual</i> . |
| 3. Caustic liquid/chemical burn hazard | 6. Keep bystanders a safe distance from the battery. |

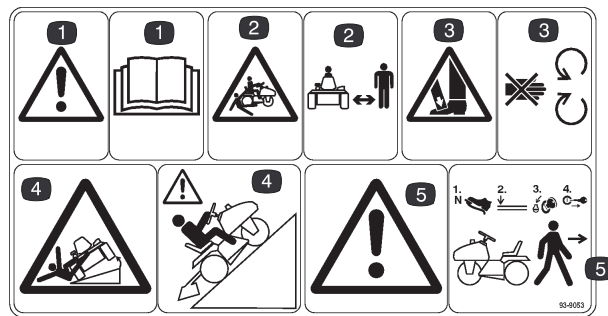

93-9053

1. Warning—read the operator's manual.
2. Crushing/dismemberment hazard—keep bystanders away.
3. Cutting hazard of feet—stay away from moving parts.
4. Tipping hazard—take caution when operating on slopes.
5. Warning—before leaving the operator's position, put the traction control pedal in neutral, turn the engine off, and remove the ignition key.

MAINTENANCE FREE • SANS ENTRETIEN • LIBRE DE MANTENIMIENTO

↙ NIVEAU MAXIMUM
NIVEAU MINIMUM ↘
↙ MAXIMUM FILL
MINIMUM FILL ↘
↙ CAPACIDAD MAXIMA
CAPACIDAD MINIMA ↘

⚠ DANGER/POISON ¡PELIGRO/VENENO!

<p>SHIELD EYES. EXPLOSIVE GASES CAN CAUSE BLINDNESS OR INJURY.</p> <p>PROTÉGER LES YEUX. GAZ EXPLOSIFS PEUVENT RENDRE AVEUGLE OU PROVOQUER DES LÉSIONS.</p> <p>PROTEJA LOS OJOS. GASES EXPLOSIVOS PUEDEN CAUSAR CEGUERA O DAÑO.</p>	<p>NO SPARKS • FLAMES • SMOKING</p> <p>ÉLOIGNER • ÉTINCELLES • FLAMMES • CIGARETTES</p> <p>NO CHISPAS • FLAMAS • FUMAR</p>	<p>SULFURIC ACID CAN CAUSE BLINDNESS OR SEVERE BURNS.</p> <p>ACIDE SULFURIQUE PEUT RENDRE AVEUGLE OU PROVOQUER DES BRÛLURES GRAVES.</p> <p>ACIDO SULFURICO PUEDE CAUSAR CEGUERA O QUEMADURAS SEVERAS.</p>	<p>FLUSH EYES IMMEDIATELY WITH WATER. GET MEDICAL HELP FAST.</p> <p>RINCER IMMEDIATEMENT LES YEUX A GRANDE EAU. CONTACTER RAPIDEMENT UN MEMBRE DE LA PROFESSION MEDICALE.</p> <p>LAVE LOS OJOS DE INMEDIATO. CONSIGA AYUDA MEDICA RAPIDO.</p>
--	---	--	--

KEEP OUT OF THE REACH OF CHILDREN. DO NOT TIP. DO NOT OPEN BATTERY!
 MAINTENIR HORS DE LA PORTÉE DES ENFANTS. NE RENVERSEZ PAS. N'OUVREZ PAS LA BATTERIE!
 MANTENGASE FUERA DEL ALCANCE DE LOS NIÑOS. NO INCLINE. NO ABRA LA BATERIA!

HOW TO ACTIVATE DRY CHARGED BATTERIES

1. Use only battery electrolyte (1.265 Sp. Gr.) to fill battery initially.
2. Do not overfill. Let stand for 15 minutes.
3. Charge battery at 4-5 amps until specific gravity is 1.250 or higher and temperature is at least 60°F. – all cells gassing freely.
4. After battery has been activated, add only water to replace normal loss.

Dist. by: /por:/par: The Toro Company, Bloomington, MN 55420 MADE IN U.S.A. • FABRIQUE AUX É.U.A. • HECHO EN E.U.A.

104-4164

- | | | | |
|--|---|---|--|
| 1. Contains lead; do not discard. | 4. No sparks, flame, or smoking | 6. Flush eyes immediately with water and get medical help fast. | 8. Minimum fill line |
| 2. Recycle | 5. Sulfuric acid can cause blindness or severe burns. | 7. Maximum fill line | 9. Instructions for activating the battery |
| 3. Wear eye protection; explosive gases can cause blindness and other injuries | | | |

Specifications

General Specifications

Configuration	Short wheel base tricycle vehicle with rear engine placement. All wheels powered. Front wheel steering.
Engine	Briggs & Stratton, V-twin cylinder, 4 cycle, OHV, air cooled, gas engine with cast iron sleeves. 18 hp @ 3600 RPM, 34.8 cu. in. (570 cc) displacement, 1-3/4 US qt. (1.66 l) oil capacity. Electronic ignition. Full pressure lubrication, oil filter. Engine and remote mounted air cleaners.
Instrumentation	Hour meter
Controls	Hand operated throttle, choke, lift lever and parking brake. Foot pedal controls traction forward / reverse speed.
Steering	Front wheel steering with adjustable tilt steering wheel.
Gas Tank	5-1/2 gallon (25 l) capacity
Battery	12 volt, lead acid, 280 CCA.
Drive	Hydraulic. Coupling driven variable displacement piston pump with integral auxiliary charge pump to hydraulic motors which directly drive wheels.
Hydraulic Oil Filter	25 micron, spin-on type
Hydraulic Oil Reservoir	3 gallon (11.4 l) capacity
Valve	Single section for raising and lowering of implement with float
Cylinder	Double acting
Tires	22 x 11.00-8 two-ply pneumatic tubeless. De-mountable and interchangeable. Recommended tire pressure is 4–6 psi (28–41 kPa).
Speeds (at 3200 RPM)	Variable between 0 and 11 MPH (0 and 18 km/h) forward and 0 and 4 MPH (0 and 6 km/h) reverse
Seat Adjustment	4 inches (10.2 cm) fore and aft. Additional 1.75 inches forward adjustment available by using front mounting holes. Additional adjustment for small operator attained by removing seat slides and base and mounting seat directly to support.

Measurements

Width without implement	58 in. (148 cm)
Width with rake Model No. 08812	75 in. (191 cm)
Height	45-1/4 in. (115 cm)
Length without implement	64-1/2 in. (164 cm)
Wheelbase	42-3/4 in. (109 cm)
Net weight (wet)	810 lb. (302 kg)

Optional Equipment

Drag Mat	Model No. 08850	Cyclone Debris Blower	Model No. 08857
Rake Mounting Kit	Model No. 08814	Blower Mounting Kit	Model No. 08859
Tooth Rake Kit	Model No. 08812	Blower Chute Kit	Model No. 08860
Weeder Kit	Model No. 08815	Draw Bar	Part No. 92-2330
Spring Rake Kit	Model No. 08813	Deluxe Grammer Seat	Model No. 30797
Finish Grader	Model No. 08867	Seat Adapter Plate (30797)	Part No. 92-7171
Spiker	Model No. 08856	Spark Arrestor	Part No. 83-2240
Front Blade Kit	Model No. 08821	240 Adapter Kit	Model No. 44901
Sand Blade 240	Model No. 44900	Sand Pro 5020 CE Kit	Part No. 98-0990

Setup

Note: Determine the left and right sides of the machine from the normal operating position.

Loose Parts

Note: Use this chart as a checklist to ensure that all parts necessary for assembly have been shipped. If any of these parts are missing, total setup cannot be completed.

Description	Qty.	Use
Tire and wheel assembly	2	Installing the wheels
Lug nuts	8	
Steering wheel	1	Mounting the steering wheel
Roll pin, 1/4 x 2-1/2 in.	1	
Capscrew, 1/4-20 x 5/8 in.	2	Securing the battery cables to the battery
Locknut, 1/4-20	2	
Capscrew, 1/2-13 x 1-1/4 in.	4	Attaching the implements to the frame
Washer, 1/2	4	
Cylinder pin	1	Attaching the cylinder to the implement
Hairpin cotter	2	
Capscrew, 3/8-16 x 2-1/4 in.	1	
Locknut, 3/8-16	1	
Spacer	1	
Decals	2	Affix on machine, if desired.
Key	2	
Parts catalog	1	
Operator's Manual	1	Read before operating the machine.
Engine Operator's Manual	1	

Note: Specifications and design subject to change without notice.

Installing the Wheels

Note: Install the rear wheels to the machine while it is still on the pallet shipping blocks.

1. Mount a wheel to each wheel motor and secure them with the lug nuts. Tighten the lugs nuts evenly and gradually in a crisscross manner to 45–55 ft.-lb. (61–75 N·m).
2. Remove the shipping blocks and lower the machine onto the rear wheels.

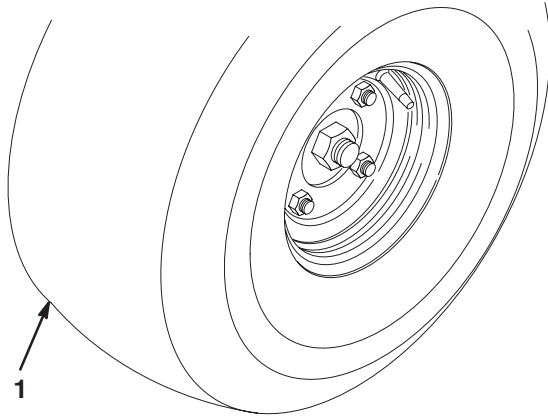

Figure 1

1. Rear wheel

Note: We suggest saving the shipping blocks, as they are the correct height for blocking the unit when changing the tires, servicing the wheel motors, or performing other service work.

Installing the Steering Wheel

1. Move the front wheel so that it points straight ahead.
2. Slide the steering wheel onto the steering shaft, aligning the mounting holes.
3. Secure the steering wheel in place with the roll pin (Fig. 2).

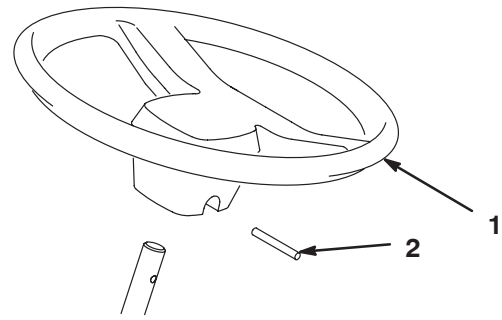

Figure 2

1. Steering wheel
2. Roll pin

Removing The Battery

1. Pivot seat upward and engage seat prop.
2. Remove (2) wing nuts and washers securing top battery hold down to side battery hold downs (Fig. 3). Remove top battery hold and remove battery.

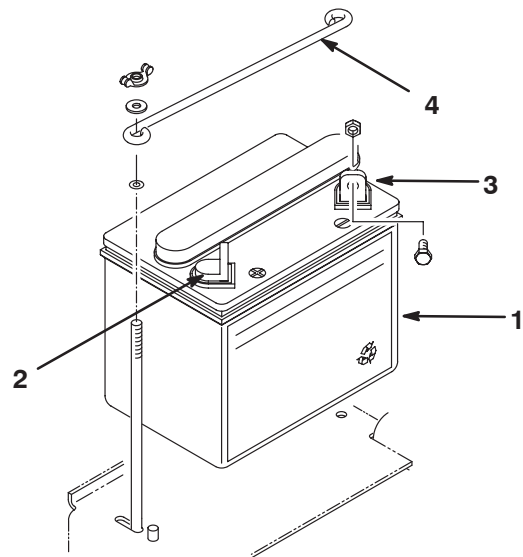

Figure 3

1. Battery
2. Positive (+) battery terminal
3. Negative (-) battery terminal
4. Top battery hold down

Activating and Charging the Battery



Warning



Battery posts, terminals, and related accessories contain lead and lead compounds, chemicals known to the State of California to cause cancer and reproductive harm. *Wash hands after handling.*

If the battery is not filled with electrolyte or activated, bulk electrolyte with 1.260 specific gravity must be purchased from a local battery supply outlet and added to the battery.



Danger



Battery electrolyte contains sulfuric acid which is a deadly poison and causes severe burns.

- Do not drink electrolyte and avoid contact with skin, eyes or clothing. Wear safety glasses to shield your eyes and rubber gloves to protect your hands.
- Fill the battery where clean water is always available for flushing the skin.

1. Remove the filler caps from the battery and slowly fill each cell until electrolyte is up to the fill line.
2. Replace the filler caps and connect a 3 to 4 amp. battery charger to the battery posts. Charge the battery at a rate of 3 to 4 amperes for 4 to 8 hours.



Warning



Charging the battery produces gasses that can explode.

Never smoke near the battery and keep sparks and flames away from battery.

3. When the battery is charged, disconnect the charger from the electrical outlet and battery posts. Allow the battery to sit for 5–10 minutes.
4. Remove the filler caps. Slowly add electrolyte to each cell until the level is up to the fill line. Install the filler caps.

Important Do not overfill the battery. Electrolyte will overflow onto other parts of the machine and severe corrosion and deterioration will result.

Installing the Battery

1. Set the battery in place, with the terminals to the outside (Fig. 3).
2. Secure the positive cable (red) to the positive (+) terminal with a 1/4–20 x 5/8 in. capscrew and locknut.



Warning



Incorrect battery cable routing could damage the machine and cables causing sparks. Sparks can cause the battery gasses to explode, resulting in personal injury.

- Always *disconnect* the negative (black) battery cable before disconnecting the positive (red) cable.
- Always *connect* the positive (red) battery cable before connecting the negative (black) cable.



Warning



Battery terminals or metal tools could short against metal machine components causing sparks. Sparks can cause the battery gasses to explode, resulting in personal injury.

- When removing or installing the battery, do not allow the battery terminals to touch any metal parts of the machine.
- Do not allow metal tools to short between the battery terminals and metal parts of the machine.

3. Secure the two small black wires and the negative cable (black) to the negative (–) terminal of the battery with a 1/4–20 x 5/8 in. capscrew and locknut (Fig. 3).
4. Coat the terminals and mounting fasteners with petroleum jelly to prevent corrosion. Slide the rubber boot over the positive (+) terminal to prevent a possible short from occurring.
5. Install the top battery hold down to side battery hold downs and secure with washers and wing nuts.
6. Release seat prop and lower seat.

Installing the Decals

Affix an Infield Pro[®] decal over each Sand Pro decal, if desired.

Before Operating



Caution



If you leave the key in the ignition switch, someone could accidentally start the engine and seriously injure you or other bystanders.

Remove the key from the ignition and disconnect the wire from the spark plug before you do any maintenance. Set the wire aside so that it does not accidentally contact the spark plug.

Checking the Crankcase Oil

The engine is shipped with 1-3/4 US quarts (1.66 l) (w/ filter) of oil in the crankcase; however, the oil level must be checked before and after the engine is first started.

The engine uses any high-quality detergent oil having the American Petroleum Institute (API) "service classification" SJ. The recommended viscosity (weight) is SAE 30.

1. Position the machine on a level surface.
2. Remove the engine cover.
3. Pull out the dipstick (Fig. 4) and wipe it with a clean rag. Insert the dipstick into the tube and make sure that it is seated fully. Remove the dipstick from the tube and check the oil level. If the oil level is low, remove the filler cap from the valve cover (next to the dipstick) and add enough oil to raise the level to the FULL mark on the dipstick.

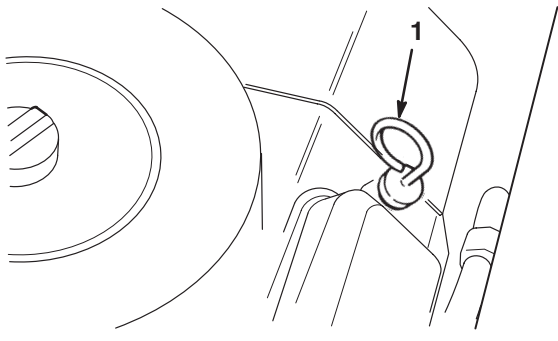

Figure 4

1. Dipstick

4. Install the dipstick firmly in place.

Important The dipstick must be fully seated in the tube to provide proper sealing of the engine crankcase. Failure to seal the crankcase may result in engine damage.

5. Install the engine cover.

Important Check the oil level every 8 operating hours or daily. Initially, change the oil after the first 8 hours of operation; thereafter, under normal conditions, change the oil every 25 hours and the filter every 100 hours. However, change the oil more frequently when the engine is operated in extremely dusty or dirty conditions.

Filling the Fuel Tank

Use UNLEADED Regular Gasoline suitable for automotive use (87 pump octane minimum). Leaded regular gasoline may be used if unleaded regular is not available.

Important Never use methanol, gasoline containing methanol, or gasohol containing more than 10% ethanol because the fuel system could be damaged. Do not mix oil with gasoline.



Danger



In certain conditions, gasoline is extremely flammable and highly explosive. A fire or explosion from gasoline can burn you and others and can damage property.

- Fill the fuel tank outdoors, in an open area, when the engine is cold. Wipe up any gasoline that spills.
- Do not fill the fuel tank completely full. Add gasoline to the fuel tank until the level is 1 in. (25 mm) below the bottom of the filler neck. This empty space in the tank allows gasoline to expand.
- Never smoke when handling gasoline, and stay away from an open flame or where gasoline fumes may be ignited by a spark.
- Store gasoline in an approved container and keep it out of the reach of children. Never buy more than a 30-day supply of gasoline.
- Always place gasoline containers on the ground away from your vehicle before filling.
- Do not fill gasoline containers inside a vehicle or on a truck or trailer bed because interior carpets or plastic truck bed liners may insulate the container and slow the loss of any static charge.
- When practical, remove gas-powered equipment from the truck or trailer and refuel the equipment with its wheels on the ground.
- If this is not possible, then refuel such equipment on a truck or trailer from a portable container, rather than from a gasoline dispenser nozzle.
- If a gasoline dispenser nozzle must be used, keep the nozzle in contact with the rim of the fuel tank or container opening at all times until fueling is complete.

⚠
Warning
⚠

Gasoline is harmful or fatal if swallowed. Long-term exposure to vapors can cause serious injury and illness.

- **Avoid prolonged breathing of vapors.**
- **Keep face away from nozzle and gas tank or conditioner opening.**
- **Keep gas away from eyes and skin.**

Fuel tank capacity is approximately 5-1/2 gallons (25 l).

1. Clean the area around the fuel tank cap (Fig. 5).
2. Remove the fuel tank cap.
3. Fill the tank to about 1 in. (25 mm) below the top of the tank (bottom of the filler neck). **Do not overfill.** Install the cap.
4. Wipe up any fuel that may have spilled to prevent a fire hazard.

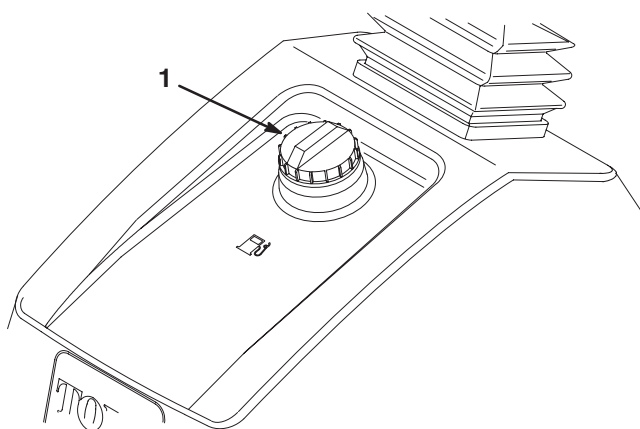

Figure 5

1. Fuel tank cap

Checking the Hydraulic System

The machine's reservoir is filled at the factory with approximately 3 gallons (11.4 l) of high quality hydraulic fluid. **Check the level of hydraulic fluid before the engine is first started and daily thereafter.** Appropriate hydraulic oils are listed below.

The following list is not assumed to be all-inclusive. Hydraulic fluids produced by other manufacturers may be used if they can cross reference to find an equivalent to the products listed. Toro will not assume responsibility for damage caused by improper substitutions, so use only products from reputable manufacturers who will stand behind their recommendation.

Multigrade Hydraulic Fluid—ISO VG 46

Normal Climate: 0°F (-18°C) to 110°F (43°C)

Mobil	DTE 15M
Amoco	Rykon Premium ISO 46
Chevron	Rykon Premium Oil ISO 46
Conoco	Hydroclear AW MV 46
Exxon	Univis N46
Pennzoil	AWX MV46
Shell	Tellus T 46
Texaco	Rando HDZ 46

Important The ISO VG 46 Multigrade fluid has been found to offer optimal performance in a wide range of temperature conditions. For operation in consistently high ambient temperatures, 65°F (18°C) to 120°F (49°C), ISO VG 68 hydraulic fluid may offer improved performance.

Note: Many hydraulic fluids are almost colorless, making it difficult to spot leaks. A red dye additive for the hydraulic system oil is available in 2/3 oz. (20 ml) bottles. One bottle is sufficient to 4–6 gal (15–23 l) of hydraulic oil. Order Part No. 44-2500 from your Authorized Toro Distributor.

1. Remove the cap from the hydraulic oil reservoir (Fig. 6).

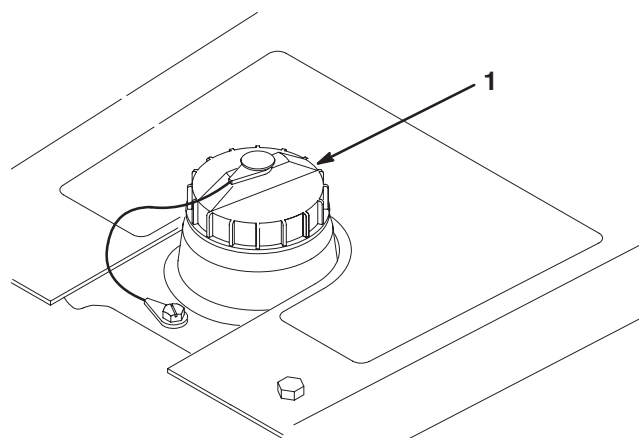

Figure 6

1. Oil reservoir cap
2. Check the oil level in the reservoir. The oil level should be up to the top of the cone point on the tank screen.
3. If the fluid level is low, slowly fill the reservoir with the appropriate hydraulic fluid until the level reaches the bottom of the screen. **Do not overfill.**
4. Install the reservoir cap.

Important To prevent system contamination, clean the top of the hydraulic oil containers before puncturing. Ensure that the pour spout and funnel are clean.

Checking the Tire Pressure

Check the tire pressure before operating the machine. The correct air pressure in the front and rear tires is 4–6 psi (28–41 kPa).

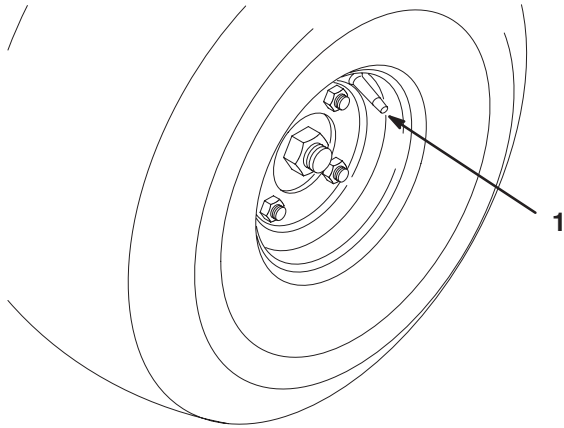

Figure 7

1. Air valve

Operation

Note: Determine the left and right sides of the machine from the normal operating position.

Using the Controls

Traction and Stopping Pedal

The traction pedal (Fig. 8) has 3 functions: to make the machine move forward, to move it backward, and to stop the machine. Using the heel and toe of the right foot, depress the top of the pedal to move forward and the bottom of pedal to move backward or to assist in stopping when moving forward (Fig. 9). Also, allow the pedal to move or move it to the neutral position to stop the machine. For operator comfort, **do not rest heel of the foot on reverse when operating forward** (Fig. 10).

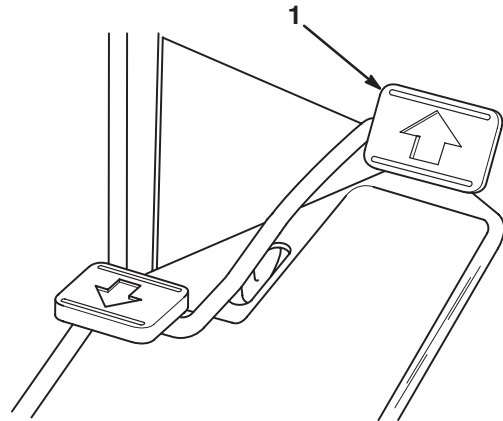

Figure 8

1. Traction and stopping pedal



Figure 9

Ground speed is proportionate to how far traction pedal is depressed. For maximum ground speed, the pedal must be fully depressed while the throttle is in the Fast position. To get maximum power or when ascending a hill, have the throttle in the Fast position while depressing the pedal slightly to keep the engine RPM high. When the engine RPM begins to decrease, release the pedal slightly to allow the RPM to increase.

Important For maximum pulling power, the throttle should be in the Fast position and the traction pedal just barely depressed.



Caution



Use the maximum ground speed only when driving from one area to another.

Maximum speed is not recommended when using an attached or towed implement.

Important Do not operate in reverse with the implement in the down (operating) position, or the implement could be severely damaged.

Ignition Switch

The ignition switch (Fig. 10), used to start and stop the engine, has three positions: Off, Run, and Start. Rotate the key clockwise to the Start position to engage the starter motor. Release the key when the engine starts. The key will move automatically to the On position. To shut the engine off, rotate the key counterclockwise to the Off position.

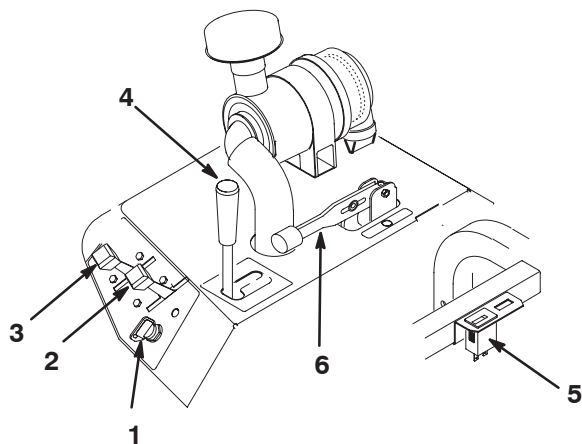

Figure 10

- | | |
|---------------------|------------------|
| 1. Ignition switch | 4. Lift lever |
| 2. Throttle control | 5. Parking brake |
| 3. Choke control | 6. Hour meter |

Choke Control

To start a cold engine, close carburetor choke by moving choke control (Fig. 10) forward to the “CLOSED” position. After engine starts, regulate choke to keep engine running smoothly. As soon as possible, open the choke by pulling upward to the “OPEN” position. A warm engine requires little or no choking.

Throttle Control

The throttle control lever (Fig. 10) connects to and operates the throttle linkage to the carburetor. The control has 2 positions: Slow and Fast. The engine speed can be varied between the 2 settings.

Note: The engine cannot be stopped by the throttle control.

Lift Lever

To raise the implement, pull the lift lever (Fig. 10) back; to lower the implement, push the lever forward. For the float position, move the lever into the detent position. When the desired position is attained, release the lever and it will return to neutral.

Note: The machine has a double-acting lift cylinder. Down pressure can be applied to the implement for certain operating conditions.

Parking Brake

To engage the parking brake (Fig. 10), pull back on the lever. To disengage it, push the lever forward.

Hour Meter

The hour meter, located under seat, (Fig. 10) indicates the total hours of machine operation. The hour meter starts to function whenever the key switch is rotated to the On position.

Steering Wheel Tilt Lever

Steering wheel tilt lever, (Fig. 11) on left side of steering column, allows steering wheel to be adjusted for operator comfort.

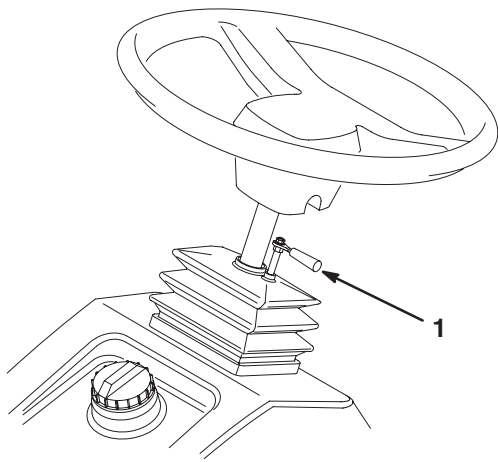

Figure 11

1. Steering wheel tilt lever

Seat Adjustment

Move the lever on the left side of the seat forward, slide the seat to the desired position, and release the lever to lock the seat into position.

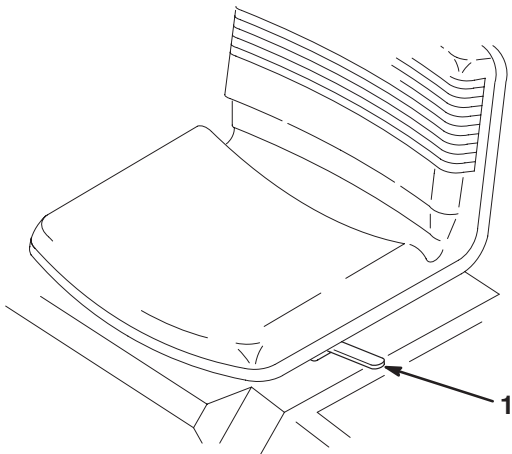

Figure 12

1. Seat adjusting lever

Fuel Shutoff Valve

Close the fuel shutoff valve (Fig. 13) when storing the machine.

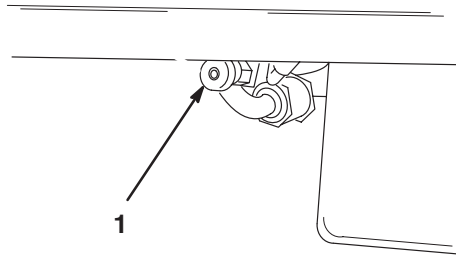

Figure 13

1. Fuel shutoff valve

Starting and Stopping the Engine

1. Remove your foot from the traction pedal, make sure that the pedal is in the neutral position, and engage the parking brake.
2. Push the choke lever forward to the On position (when starting a cold engine) and the throttle lever to the Slow position.
3. Insert the key into the ignition switch and rotate it clockwise to start the engine. Release the key when the engine starts. Regulate the choke to keep the engine running smoothly.

Important To prevent overheating of the starter motor, do not engage the starter longer than 10 seconds. After 10 seconds of continuous cranking, wait 60 seconds before engaging the starter motor again.

4. When the engine is started for the first time, or after an overhaul of the engine, operate the machine in forward and reverse for 1 to 2 minutes. Also operate the lift lever to be sure of proper operation of all parts.
5. To stop the engine, move the throttle control to the Slow position and rotate the ignition key to Off. Remove the key from the switch to prevent accidental starting.
6. Close the fuel shutoff valve before storing the machine.





Caution



Shut the engine off and wait for all moving parts to stop before checking for oil leaks, loose parts, and other malfunctions.

Checking the Interlock System Operation

 **Caution** 

If safety interlock switches are disconnected or damaged the machine could operate unexpectedly causing personal injury.

- **Do not tamper with the interlock switches.**
- **Check the operation of the interlock switches daily and replace any damaged switches before operating the machine.**
- **Replace switches every two years regardless of whether they are operating properly or not.**

The purpose of the interlock system is to prevent the engine from cranking or starting unless the traction pedal is in the neutral position.

1. Check the interlock operation in a wide open area free of debris and bystanders. Stop the engine.
2. Sit on the seat. Depress the traction pedal in forward and reverse while trying to start the engine. If the engine cranks, there may be a malfunction in the interlock system. Repair it immediately. If the engine does not crank, the system is operating correctly.

Towing the Machine

In case of emergency, the machine can be towed for a short distance. However, we do not recommend this as a standard procedure.

Important Do not tow the machine faster than 2–3 MPH (3–5 km/h) because the drive system may be damaged. If the machine must be moved a considerable distance, transport it on a truck or trailer. The tires may lock up if the machine is towed too fast. If this occurs, stop towing the machine and wait for the traction circuit pressure to stabilize before resuming towing at a slower speed.

Break-In Period



Only 8 hours of operating time is required for the break-in period.

Since the first hours of operation are critical to future dependability of the machine, monitor its functions and performance closely so that minor difficulties, which could lead to major problems, are noted and can be corrected. Inspect the machine frequently during break-in for signs of oil leakage, loose fasteners, or any other malfunction.

Operating Characteristics

Practice driving the machine because its operating characteristics are different than some utility vehicles. Two points to consider when operating the vehicle are transmission and engine speed.

To maintain somewhat constant engine RPM, depress the traction pedal slowly. This allows the engine to keep up with the ground speed of the vehicle. By contrast, pushing down quickly on the traction pedal will reduce engine RPM and, as a result, there will not be enough torque-power to move the vehicle. Therefore, to transfer maximum power to the wheels, move the throttle to Fast and slightly depress the traction pedal. By comparison, maximum ground speed with no load results when the throttle is in the Fast position and the traction pedal is slowly but fully depressed. In summary, always keep the engine RPM high enough to deliver maximum torque-power to the wheels.

 **Caution** 

Operating the machine demands attention to prevent tipping or loss of control.

- **Use care when entering and leaving sand traps.**
- **Use extreme caution around ditches, creeks, or other hazards.**
- **Use caution when operating the machine on a steep slope.**
- **Reduce your speed when making sharp turns or when turning on hillsides.**
- **Avoid sudden stops and starts.**
- **Do not go from reverse to full forward without first coming to a complete stop.**

Inspecting and Cleaning the Machine

At the completion of operation, thoroughly wash the machine with a garden hose—without a nozzle—so that excessive water pressure will not cause contamination and damage to the seals and bearings.

Make sure that the cooling fins and area around the engine cooling air intake are kept free of debris. After cleaning, inspect the machine for possible hydraulic fluid leaks, damage, or wear to hydraulic and mechanical components.

Maintenance

Note: Determine the left and right sides of the machine from the normal operating position.

Recommended Maintenance Schedule

Maintenance Service Interval	Maintenance Procedure
After first 8 hours	<ul style="list-style-type: none"> • Change the engine oil. • Torque the wheel lug nuts. • Replace the hydraulic oil filter.
Every 25 hours	<ul style="list-style-type: none"> • Check the battery fluid level. • Check the battery cable connections. • Change the engine oil. • Lubricate the front wheel bearing. • Lubricate the traction control linkage.
Every 100 hours	<ul style="list-style-type: none"> • Replace the engine oil filter • Inspect the remote air filter element. • Inspect the engine air filter element. • Lubricate the steering shaft grease fitting. • Check the steering chain adjustment. • Torque the wheel lug nuts.
Every 400 hours	<ul style="list-style-type: none"> • Change the hydraulic oil. • Replace the hydraulic oil filter. • Replace the remote air filter element. • Replace the engine air filter element.
Every 800 hours	<ul style="list-style-type: none"> • Replace the spark plugs. • Replace the fuel filter. • Decarbon the combustion chamber. • Adjust the valves and torque head. • Check the engine RPM (at idle and full throttle). • Drain and clean the fuel tank.
Every 1500 hours or 2 years, whichever occurs first	<ul style="list-style-type: none"> • Replace moving hoses. • Replace the traction safety switch.

Important Refer to your engine operator's manual for additional maintenance procedures.



Caution



If you leave the key in the ignition switch, someone could accidentally start the engine and seriously injure you or other bystanders.

Remove the key from the ignition and disconnect the wire from the spark plug before you do any maintenance. Set the wire aside so that it does not accidentally contact the spark plug.

Daily Maintenance Checklist

Duplicate this page for routine use.

Maintenance Check Item	For the week of:						
	Mon.	Tues.	Wed.	Thurs.	Fri.	Sat.	Sun.
Check safety interlock operation.							
Check steering operation.							
Check the engine oil level.							
Check the air filter/pre-cleaner condition.							
Clean the engine cooling fins.							
Check unusual engine noises.							
Check unusual operating noises.							
Check the hydraulic system oil level.							
Check the hydraulic hoses for damage.							
Check for fluid leaks.							
Check the fuel level.							
Check the tire pressure.							
Check instrument operation.							
Touch up damaged paint.							

Notation for Areas of Concern

Inspection performed by:		
Item	Date	Information
1		
2		
3		
4		
5		
6		
7		
8		
9		
10		
11		
12		
13		
14		
15		
16		

Lubricating the Machine

The machine has 3 grease fittings that must be lubricated regularly with No. 2 General Purpose Lithium Base Grease. Lubricate the front wheel bearing and traction control linkage after every 25 hours of operation. Lubricate the steering chain sprocket shaft every 100 hours.

Lubricate the following bearings and bushings:

- Front wheel bearing (Fig. 14)
 - Traction control linkage (Fig. 15)
 - Steering chain sprocket shaft (Fig. 16)
1. Wipe the grease fitting clean so that foreign matter cannot be forced into the bearing or bushing.
 2. Pump grease into the bearing or bushing.
 3. Wipe up excess grease.

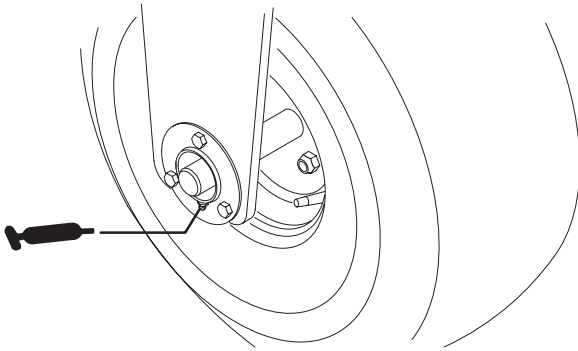

Figure 14

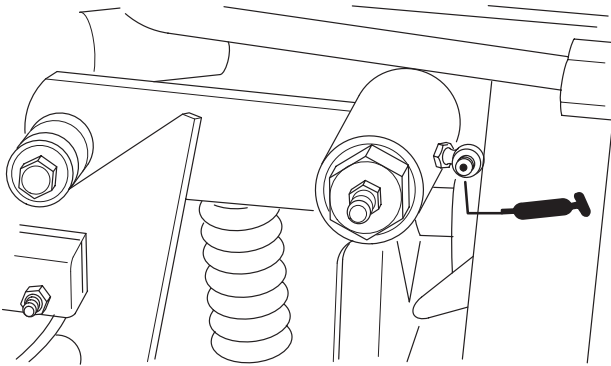

Figure 15

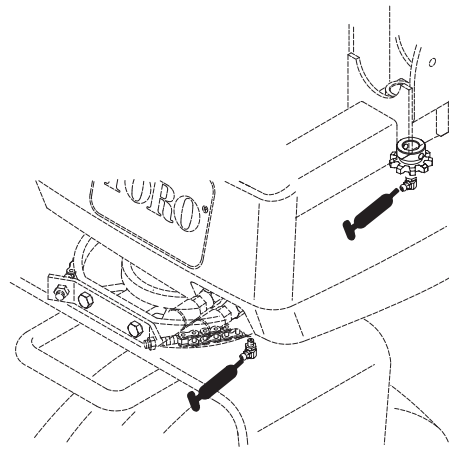

Figure 16

Note: Do not lubricate the steering chain unless it becomes stiff because of rust. If the chain rusts, it may be lubricated lightly with a **dry-type lubricant**.

Changing the Engine Oil and Filter

Change the oil initially after the first 8 hours of operation; thereafter change the oil every 25 hours and the filter every 100 hours.

1. Park the machine on a level surface and turn the engine off.
2. Remove the drain plug (Fig. 17) and let oil flow into a drain pan. When the oil stops, install the drain plug.
3. Remove the oil filter (Fig. 17). Apply a light coat of clean oil to the new filter gasket.

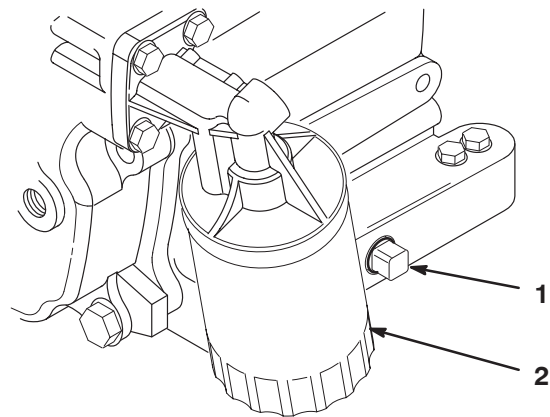

Figure 17

1. Drain plug
2. Oil filter

4. Screw the filter on by hand until the gasket contacts the filter adapter; then tighten 1/2 to 3/4 turn further. **Do not overtighten.**
5. Add oil to the crankcase; refer to Checking the Crankcase Oil, page 12.
6. Dispose of used oil properly.

Servicing the Engine Air Cleaner

Inspect the paper element every 100 hours of operation and replace it every 400 hours or when it becomes dirty or damaged. Do not wash the paper element or do not clean it with compressed air as damage will occur.

1. Park the machine on a level surface and turn the engine off.
2. Pivot the seat upward.
3. Remove the knobs and air cleaner cover (Fig. 18).
4. Remove the filter and cover plate. Inspect the filter for cleanliness, ruptures, holes, and tears. Replace a damaged filter element.

Important With the air cleaner disassembled, check the air cleaner components for damage. Replace them if necessary. Make sure that the rubber breather tube in the base plate is securely in place or severe engine damage may occur. Also, make sure that the carburetor breather hose is routed out through the engine vents.

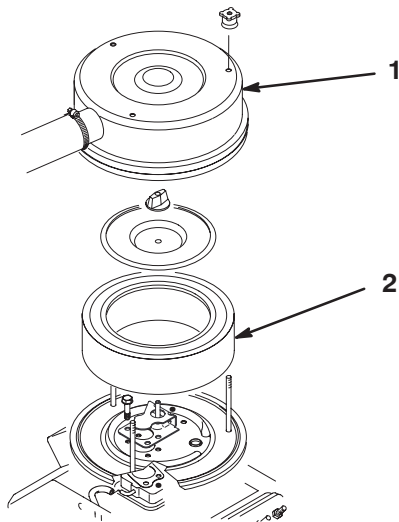

Figure 18

1. Air cleaner cover
2. Paper element

5. Install the air cleaner element and cover plate.
6. Install the air cleaner cover and secure it with the knobs.

General Air Cleaner Maintenance

Check the air cleaner body for damage which could possibly cause an air leak. Replace a damaged air cleaner body.

Replace the air cleaner filter every 400 hours (more frequently in extremely dusty or dirty conditions). Do not over-service the air filter.

Be sure that the cover is sealing around the air cleaner body.

Servicing the Remote Air Cleaner

1. Release the latches securing the air cleaner cover to the air cleaner body (Fig. 19). Separate the cover from the body. Clean the inside of the air cleaner cover.

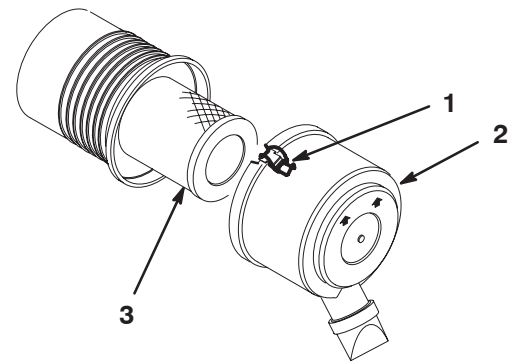

Figure 19

1. Air cleaner latches
2. Dust cap
3. Filter

2. Washing Method

- A. Prepare a solution of filter cleaner and water and soak the filter element about 15 minutes. Refer to the directions on the filter cleaner carton for complete information.
- B. After soaking the filter for 15 minutes, rinse it with clear water. Maximum water pressure must not exceed 40 psi (276 kPa) to prevent damage to the filter element. Rinse the filter from the clean side to the dirty side.
- C. Dry the filter element using warm, flowing air (160°F [71°C] max), or allow the element to air-dry. Do not use a light bulb to dry the filter element because damage could result.

3. Compressed Air Method

- A. Blow compressed air from the inside to the outside of a dry filter element. Do not exceed 100 psi (689 kPa) to prevent damage to the element.
- B. Keep the air hose nozzle at least 2 in. (5 cm) from the filter and move the nozzle up and down while rotating the filter element. Inspect the filter for holes and tears by looking through the filter toward a bright light.

4. Inspect the new filter for shipping damage. Check the sealing end of the filter. Do not install a damaged filter.
5. Insert the new filter properly into the air cleaner body. Make sure that the filter is sealed properly by applying pressure to the outer rim of the filter when installing it. Do not press on the flexible center of the filter.
6. Install the cover and secure the latches. Make sure that the cover is positioned with the TOP side up.

Adjusting the Throttle Control

Proper throttle operation is dependent upon proper adjustment of the throttle control. Before adjusting the carburetor, ensure that the throttle control is operating properly.

1. Pivot the seat upward and remove the engine shield.
2. Loosen the cable clamp screw securing the cable to the engine (Fig. 20).
3. Move the remote throttle control lever forward to the Fast position.

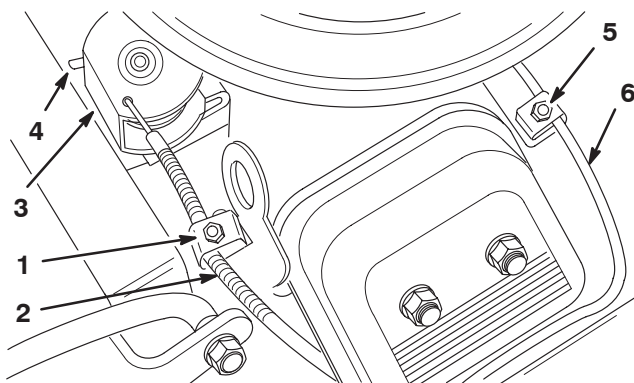

Figure 20

- | | |
|--------------------------------|-----------------------------|
| 1. Throttle casing clamp screw | 4. Stop |
| 2. Throttle cable | 5. Choke casing clamp screw |
| 3. Swivel | 6. Choke cable |

4. Pull firmly on the throttle cable until the back of the swivel contacts the stop (Fig. 20).
5. Tighten the cable clamp screw and check the engine RPM setting:

High Idle: 3150±50

Low Idle: 1750±50

Adjusting the Choke Control

1. Pivot the seat upward and remove the engine shield.
2. Loosen the cable clamp screw securing the cable to the engine (Fig. 20).
3. Move the remote choke control lever forward to the Closed position.
4. Pull firmly on the choke cable (Fig. 20) until the choke butterfly is completely closed; then tighten the cable clamp screw.

Replacing the Spark Plugs

Replace the spark plugs after every 800 operating hours or yearly, whichever occurs first.

Type: Champion RC12YC (or equivalent)

Air Gap: 0.030 in. (0.76 mm)

Note: The spark plug usually lasts a long time; however, the plug should be removed and checked whenever the engine malfunctions.

1. Clean the area around the spark plugs so that foreign matter cannot fall into the cylinder when the spark plug is removed.
2. Pull the spark plug wires off of the spark plugs and remove the plugs from the cylinder head.
3. Check the condition of the side electrode, center electrode, and center electrode insulator to ensure that there is no damage.

Important A cracked, fouled, dirty, or otherwise malfunctioning spark plug must be replaced. Do not sand-blast, scrape, or clean the electrodes by using a wire brush because grit may eventually release from the plug and fall into the cylinder. The result is usually a damaged engine.

4. Set the air gap between the center and side of the electrodes at 0.030 in. (0.76 mm) (Fig. 21). Install the correctly gapped spark plug with gasket seal, and tighten the plug to 200 in.-lb. (23 N·m). If a torque wrench is not used, tighten the plug firmly.

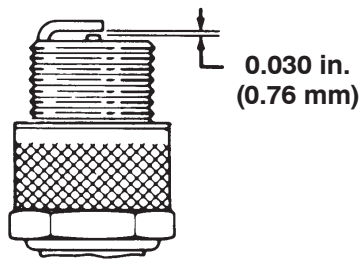

Figure 21

Cleaning the Cylinder Head Fins

To avoid overheating and possible engine damage, the cooling fins on the cylinder head must be kept clean.

Changing the Hydraulic System Oil and Filter

The hydraulic system filter must be changed initially, after the first 8 hours of operation, and thereafter every 400 hours of operation or yearly, whichever occurs first. Use a genuine Toro oil filter for replacement. The hydraulic oil must be changed every 400 hours of operation or yearly, whichever occurs first.

1. Park the machine on a level surface and turn the engine off.
2. Remove screws securing side panels from right and left sides of machine and remove panels.

Note: Place a funnel or trough under drain plug (Fig. 22), to direct oil into drain pan and prevent hydraulic oil from running onto machine components.

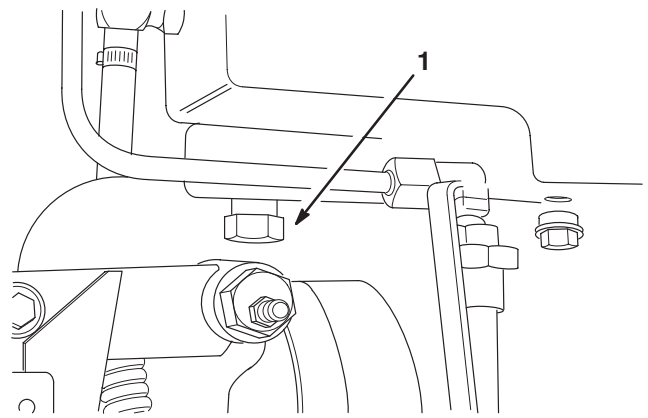

Figure 22

1. Hydraulic reservoir drain plug

3. Remove drain plug from reservoir and let hydraulic oil flow into drain pan. Reinstall and tighten plug when hydraulic oil stops draining.
4. Clean area around filter mounting area. Place drain pan under filter and remove filter.

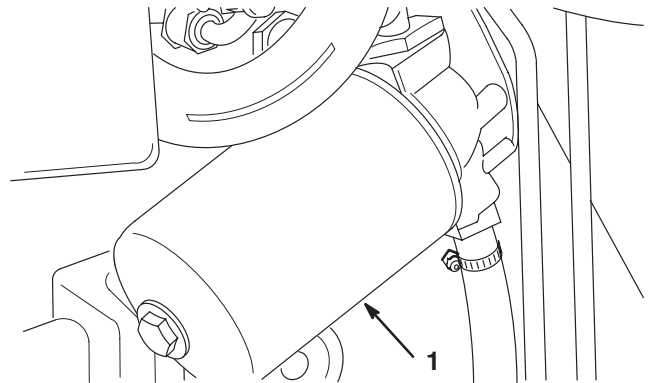

Figure 23

1. Hydraulic filter

5. Lubricate the sealing gasket, on replacement filter with hydraulic fluid, and hand turn it on until gasket contacts filter head. Then tighten 3/4 turn further. Filter should now be sealed.
6. Fill hydraulic tank with hydraulic oil until level is up to top of cone point on tank screen. **DO NOT OVERFILL.** Refer to CHECK HYDRAULIC SYSTEM, Page 11.
7. Run engine until lift cylinder extends and retracts and forward and reverse wheel motion is achieved.

8. Stop the engine and check the oil level in reservoir, add oil if necessary.
9. Check all connections for leaks.
10. Dispose of oil properly.

Checking the Hydraulic Lines and Hoses

Check the hydraulic lines and hoses daily for leaks, kinked lines, loose mounting supports, wear, loose fittings, weather deterioration, and chemical deterioration. Make all necessary repairs before operating.



Warning



Hydraulic fluid escaping under pressure can penetrate skin and cause injury.

- **Make sure all hydraulic fluid hoses and lines are in good condition and all hydraulic connections and fittings are tight before applying pressure to the hydraulic system.**
- **Keep your body and hands away from pin hole leaks or nozzles that eject high pressure hydraulic fluid.**
- **Use cardboard or paper to find hydraulic leaks.**
- **Safely relieve all pressure in the hydraulic system before performing any work on the hydraulic system.**
- **Seek immediate medical attention if fluid is injected into skin.**

Charging the Hydraulic System

Whenever a hydraulic component is repaired or replaced, the hydraulic oil filter should be changed and the hydraulic system charged.

Important Make sure that the hydraulic reservoir and filter are filled with oil at all times when charging the hydraulic system.

1. Park the machine on a level surface and turn the engine off.
2. Remove the 3 screws securing the side panel to the right side of the machine and remove the panel.
3. Loosen the locknut on the spring adjusting pin until the bearing moves freely from the cam on the lever (Fig. 24), allowing the pump shaft freedom to rotate during start-up.

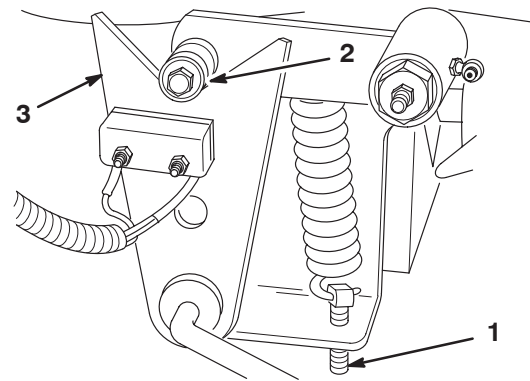

Figure 24

1. Spring adjusting pin
 2. Bearing
 3. Cam
4. Raise the front wheel and one of the rear wheels off of the floor and place support blocks under the frame.
 5. Start the engine and set the throttle to allow the engine to run at approximately 1800 RPM.
 6. Actuate the lift valve lever until the lift cylinder rod moves in and out several times. If the cylinder rod does not move after 10–15 seconds or the pump emits abnormal sounds, shut the engine off immediately and determine the cause or problem. Inspect for the following:
 - Loose filter or suction lines
 - Loose or faulty coupler on the pump
 - Blocked suction line
 - Faulty charge relief valve
 - Faulty charge pump

If the cylinder moves in 10–15 seconds, proceed to step 7.

Note: A hydrostatic transmission service manual (Bulletin No. 9646) and a repair manual (Bulletin No. 9659) can be obtained from:

Sundstrand Corporation
2800 East 13th Street
Ames, Iowa 50010

7. Operate the traction pedal in forward and reverse. The wheels that are off of the floor should rotate in the proper direction. If the wheels rotate in the wrong direction, stop the engine, remove the lines from the rear of the pump and reverse the locations. If the wheels rotate in the proper direction, stop the engine and adjust the spring adjusting pin locknut. Adjust the traction neutral position; refer to Adjusting the Traction Drive for Neutral, page 25.

8. Check the adjustment of the traction interlock switch; refer to Adjusting the Traction Interlock Switch, page 26.
9. Install the side panel.

Adjusting the Steering Chain

Since the chain and sprocket are subjected to sand thrown up by the front tire, inspect them frequently for wear. If either the chain or sprocket is worn beyond acceptable limits, **both** should be replaced.

1. Place the front wheel in the straight ahead position.
2. Adjust the locknuts until the chain is snug on both sides of the sprocket (Fig. 25).
3. Turn the steering wheel full left and full right to be sure that the chain does not bind or hang up in either direction. Adjust as required.

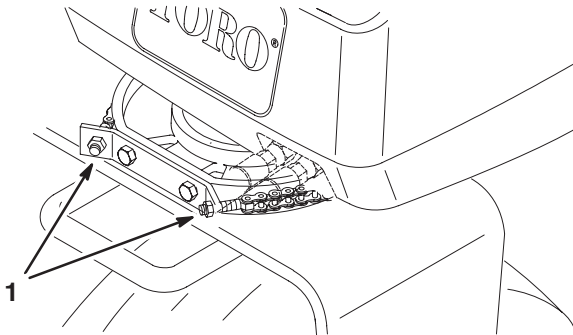

Figure 25

1. Adjusting nuts

Replacing the Fuel Filter

An inline filter is incorporated into the fuel line. Change the filter every 800 hours. Use the following procedures when replacement becomes necessary:

1. Remove the 3 screws securing the side panel to the left side of the machine and remove the panel.
2. Close fuel shut off valve, loosen the hose clamp on the carburetor side of filter and remove the fuel line from the filter (Fig. 26).
3. Place a drain pan under filter, loosen the remaining hose clamp and remove filter.
4. Install the new filter with arrow on the filter body pointing away from the fuel tank (toward carburetor).

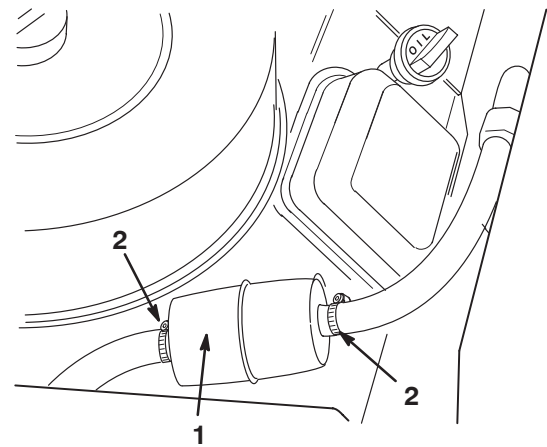

Figure 26

1. Fuel filter
2. Hose clamps

5. Slide the hose clamps onto the ends of the fuel lines. Push the fuel lines onto the fuel filter and secure them with the hose clamps. Be sure that the arrow on the side of the filter points toward the carburetor.

Adjusting the Traction Drive for Neutral

If the machine moves when the traction pedal is in the neutral position, the traction cam must be adjusted.

1. Park the machine on a level surface and turn the engine off.
2. Remove the 3 screws securing the side panel to the right side of the machine and remove the panel.
3. Raise one rear wheel off of the floor and place support blocks under the frame.
4. Loosen the locknut on the traction adjustment cam (Fig. 27).

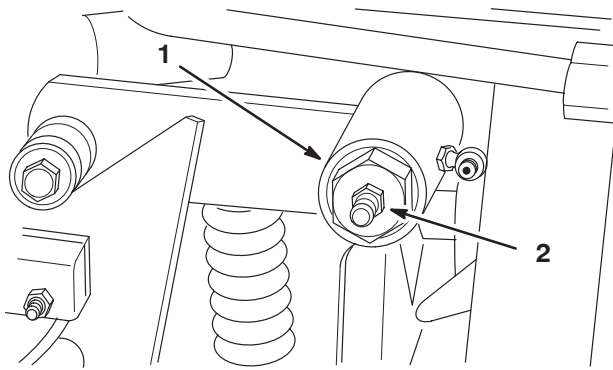

Figure 27

1. Traction adjustment cam 2. Locknut



Warning



The engine must be running so that the final adjustment of the traction adjustment cam can be performed. Contact with moving parts or hot surfaces may cause personal injury.

Keep hands, feet, face, and other body parts away from rotating parts, the muffler, and other hot surfaces.

5. Start the engine and rotate the cam hex (Fig. 27) in both directions to determine the mid position of the neutral span.
6. Tighten the locknut securing the adjustment.
7. Stop the engine.
8. Install the side panel.
9. Remove the jack stands and lower the machine to the shop floor. Test drive the machine to make sure that it does not move when the traction pedal is in neutral.

Adjusting the Traction Interlock Switch

1. Adjust the transmission for neutral; refer to Adjusting the Traction Drive for Neutral, page 25.
2. Activate the pump lever to ensure that all parts are operating freely and seated properly.
3. Rotate the switch adjusting screw until there is a gap between the head of the screw and the switch button.

4. Rotate the adjusting screw until it contacts the switch button. Continue to rotate the screw until the circuit is completed (the switch clicks). After the switch clicks, rotate the adjusting screw an additional 1/2 turn.
5. Check for proper operation.

Adjusting the Pedal for Forward

The pedal must be adjusted for forward if the jam nuts on the control rod are loosened or if the pedal is removed.

1. Park the machine on a level surface, turn the engine off, and engage the parking brake.
2. Make sure that the pump is in neutral.
3. Loosen the jam nuts on the control rod (Fig. 28).

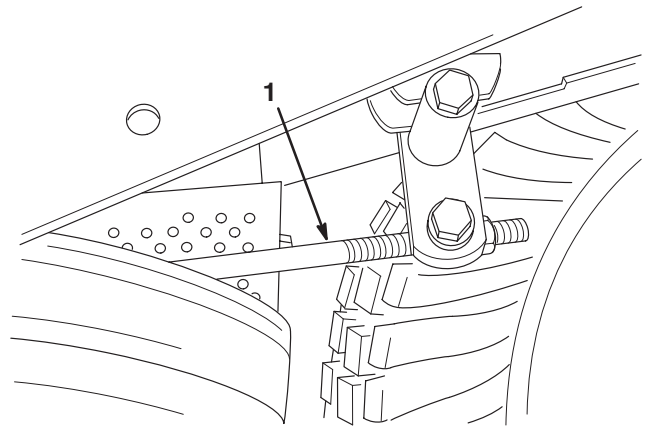

Figure 28

1. Control rod

4. Press down on the forward pad of the pedal until the pedal rod contacts the footrest. Tighten the jam nuts.

Adjusting Steering Wheel Tilt Lever

If steering wheel tilt lever does not lock after adjusting wheel position an adjustment to the lever is required.

1. Loosen capscrew securing lever to locking pin.
2. Lift lever off hex on locking pin. Rotate lever counterclockwise to next hex on pin.
3. Push lever onto locking pin hex and secure with capscrew.

4. Check adjustment and repeat if necessary.

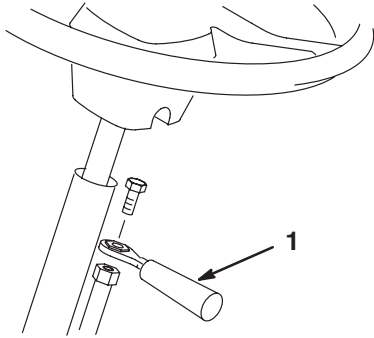

Figure 29

1. Lever

Adjusting the Parking Brake

The brakes have been set at the factory for optimum performance, but after use and wear an adjustment may be required.

1. Park the machine on a level surface, turn the engine off, and block the wheels.
2. Loosen the jam nut on the actuator rod (Fig. 30). Remove the cotter pin retaining the actuator rod. Increase or decrease the actuator rod length by rotating the rod. Install the actuator rod using a new cotter pin and secure the jam nut.

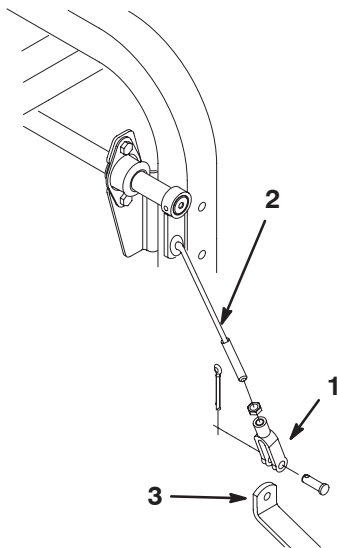

Figure 30

1. Adjustment rod clevis
2. Adjustment rod
3. Brake arm

3. If modifying the actuator rod length does not improve brake performance, adjust both the left and right adjustment rods equally using the same procedure described in step 2.

Adjusting Lift Lever

The lift lever detent plate (Fig. 31) can be adjusted if the attachment does not float properly (follow ground contour) during operation.

1. Park the machine on a level surface, turn engine off, set parking brake and block wheels.
2. Loosen (2) capscrews securing lift lever detent plate to fender and frame.
3. Thru access hole, in front fender, insert a 3/16" hex key into jacking screw on lift lever detent plate.

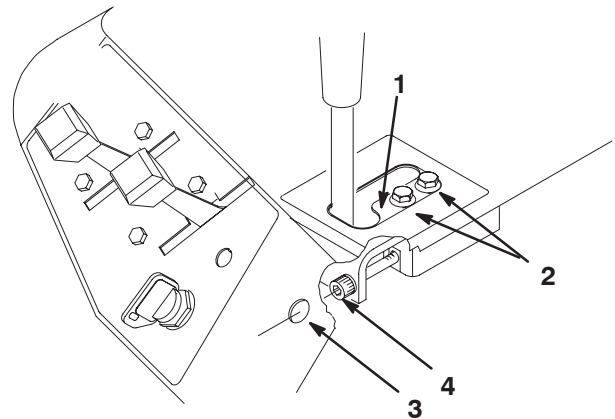

Figure 31

1. Lift lever detent plate
2. Mounting screws
3. Access hole
4. Jacking screw



Warning



The engine must be running so that the final adjustment of the lift lever detent plate can be performed. Contact with moving parts or hot surfaces may cause personal injury.

Keep hands, feet, face, and other body parts away from rotating parts, the muffler, and other hot surfaces.

4. Start traction unit engine.
5. With engine running and lift lever in the FLOAT position, rotate jacking screw until lift cylinder can be extended and retracted by hand.

6. Tighten both lift lever detent plate mounting screws to secure adjustment.

Storing the Battery

If the machine will be stored for more than 30 days, remove the battery and charge it fully. Either store it on the shelf or on the machine. Leave the cables disconnected if it is stored on the machine. Store the battery in a cool atmosphere to avoid quick deterioration of the charge in the battery. To prevent the battery from freezing, make sure that it is fully charged. The specific gravity of a fully charged battery is 1.250.



Caring for the Battery

The battery electrolyte level must be properly maintained and the top of the battery kept clean. If the machine is stored in a location where temperatures are extremely high, the battery will run down more rapidly than if the machine is stored in a location where temperatures are cool.

If corrosion occurs at the battery terminals, disconnect the cables, negative (–) cable first, and scrape the clamps and terminals separately. Reconnect the cables, positive (+) cable first, and coat the terminals with petroleum jelly.

Check the electrolyte level every 25 operating hours or, if the machine is in storage, every 30 days.

Maintain the cell level with distilled or demineralized water. Do not fill the cells above the fill line.



 **Danger** 

Battery electrolyte contains sulfuric acid which is a deadly poison and causes severe burns.

- **Do not drink electrolyte and avoid contact with skin, eyes or clothing. Wear safety glasses to shield your eyes and rubber gloves to protect your hands.**
- **Fill the battery where clean water is always available for flushing the skin.**

Keep the top of the battery clean by washing it periodically with a brush dipped in ammonia or bicarbonate of soda solution. Flush the top surface with water after cleaning. Do not remove the fill cap while cleaning.

The battery cables must be tight on the terminals to provide good electrical contact.

 **Warning** 

Incorrect battery cable routing could damage the machine and cables causing sparks. Sparks can cause the battery gasses to explode, resulting in personal injury.

- **Always *disconnect* the negative (black) battery cable before disconnecting the positive (red) cable.**
- **Always *connect* the positive (red) battery cable before connecting the negative (black) cable.**

Electrical Schematic

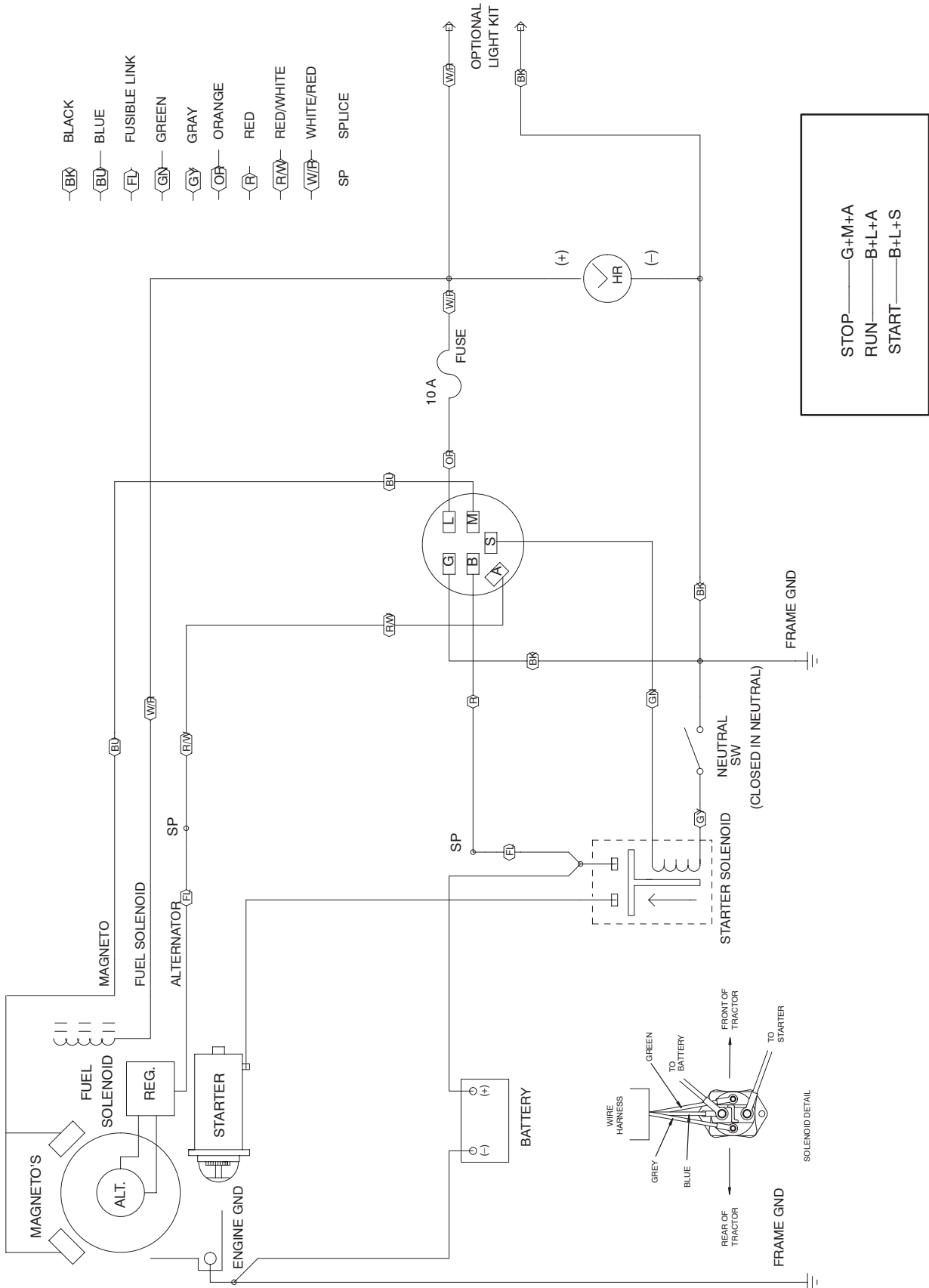

Hydraulic Schematic

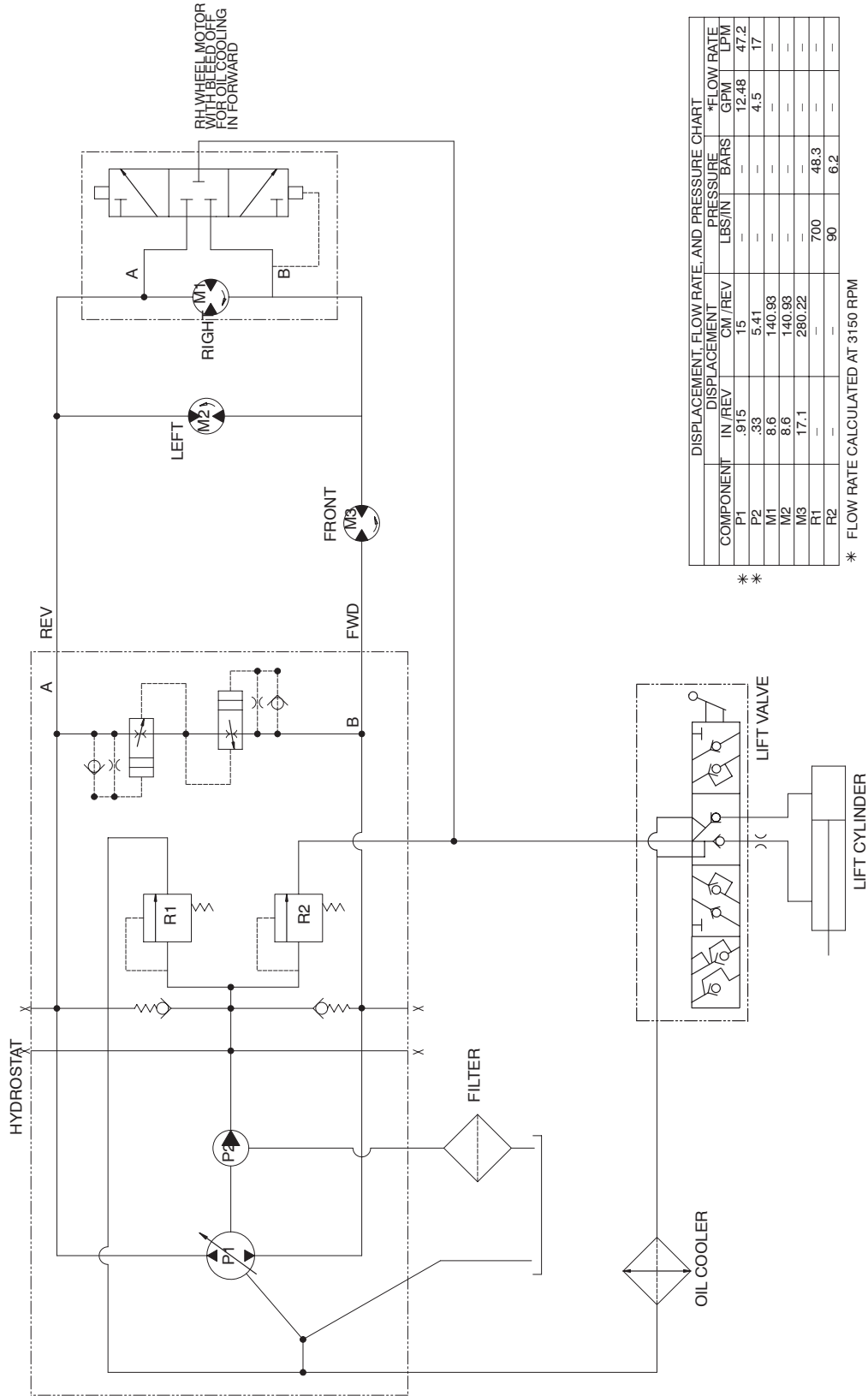

DISPLACEMENT, FLOW RATE, AND PRESSURE CHART

COMPONENT	IN/REV	CM/REV	LBS/IN	PRESSURE BARS	GPM	*FLOW RATE LPM
P1	.915	15	—	—	12.48	47.2
P2	.33	5.41	—	—	4.5	17
M1	8.6	140.93	—	—	—	—
M2	8.6	140.93	—	—	—	—
M3	17.1	280.22	—	—	—	—
R1	—	—	700	48.3	—	—
R2	—	—	90	6.2	—	—

* FLOW RATE CALCULATED AT 3150 RPM

**



Evaporative Emission Control Warranty Statement
California Evaporative Emission Control Warranty Statement
Your Warranty Rights and Obligations

Introduction

The California Air Resources Board and The Toro® Company are pleased to explain the evaporative emission control system's warranty on your 2006 model year equipment. In California, new equipment that use small off-road engines must be designed, built, and equipped to meet the State's stringent anti-smog standards. The Toro Company must warrant the evaporative emission control system on your equipment for two years provided there has been no abuse, neglect or improper maintenance of your equipment. Your evaporative emission control system may include parts such as: fuel lines, fuel line fittings, and clamps.

Manufacturer's Warranty Coverage:

This evaporative emission control system is warranted for two years. If any evaporative emission-related part on your equipment is defective, the part will be repaired or replaced by The Toro® Company.

Owner's Warranty Responsibilities:

- As the equipment owner, you are responsible for performance of the required maintenance listed in your Operator's Manual. The Toro® Company recommends that you retain all receipts covering maintenance on your equipment, but The Toro® Company cannot deny warranty solely for the lack of receipts.
- As the equipment owner, you should however be aware that The Toro® Company may deny you warranty coverage if your emission warranty parts have failed due to abuse, neglect, or improper maintenance or unapproved modifications.
- You are responsible for presenting your equipment to an Authorized Service Dealer as soon as the problem exists. The warranty repairs should be completed in a reasonable amount of time, not to exceed 30 days. If you have a question regarding your warranty coverage, you should contact The Toro® Company at 1-952-948-4027 or call us toll free at the number listed in your Toro Warranty statement.

Defects Warranty Requirements:

7. The warranty period begins on the date the engine or equipment is delivered to an ultimate purchaser.
8. General Evaporative Emissions Warranty Coverage. The emission warranty parts must be warranted to the ultimate purchaser and any subsequent owner that the evaporative emission control system when installed was
 - A. Designed, built, and equipped so as to conform with all applicable regulations; and
 - B. Free from defects in materials and workmanship that causes the failure of a warranted part for a period of two years.
9. The warranty on evaporative emissions-related parts will be interpreted as follows:
 - A. Any warranted part that is not scheduled for replacement as required maintenance in the written instructions must be warranted for the warranty period of two years. If any such part fails during the period of warranty coverage, it must be repaired or replaced by The Toro® Company. Any such part repaired or replaced under the warranty must be warranted for a time not less than the remaining warranty period.
 - B. Any warranted part that is scheduled only for regular inspection in the written instructions must be warranted for the warranty period of two years. A statement in such written instructions to the effect of "repair or replace as necessary" will not reduce the period of warranty coverage. Any such part repaired or replaced under warranty must be warranted for a time not less than the remaining warranty period.
 - C. Any warranted part that is scheduled for replacement as required maintenance in the written instructions must be warranted for the period of time prior to the first scheduled replacement point for that part. If the part fails prior to the first scheduled replacement, the part must be repaired or replaced by The Toro® Company. Any such part repaired or replaced under warranty must be warranted for a time not less than the remainder of the period prior to the first scheduled replacement point for the part.
 - D. Repair or replacement of any warranted part under the warranty provisions of this article must be performed at no charge to the owner at an Authorized Service Dealer.
 - E. Notwithstanding the provisions of subsection (D) above, warranty services or repairs must be provided at an Authorized Service Dealer.
 - F. The owner must not be charged for diagnostic labor that leads to the determination that a warranted part is in fact defective, provided that such diagnostic work is performed at an Authorized Service Dealer.
 - G. Throughout the evaporative emission control system's two year warranty period, The Toro® Company must maintain a supply of warranted parts sufficient to meet the expected demand for such parts.
 - H. Manufacturer approved replacement parts must be used in the performance of any warranty maintenance or repairs and must be provided without charge to the owner. Such use will not reduce the warranty obligations of The Toro® Company.
 - I. The use of any add-on or modified parts will be grounds for disallowing a warranty claim made in accordance with this article. The Toro® Company will not be liable under this Article to warrant failures of warranted parts caused by the use of an add-on or modified part.
 - J. The Toro® Company shall provide any documents that describe the warranty procedures or policies within five working days of request by the Air Resources Board.

Emission Warranty Parts List:

The following list includes the parts covered under this warranty:

- Fuel Lines
- Fuel Line Fittings
- Clamps



The Toro General Commercial Products Warranty

A Two-Year Limited Warranty

Conditions and Products Covered

The Toro Company and its affiliate, Toro Warranty Company, pursuant to an agreement between them, jointly warrant your Toro Commercial Product ("Product") to be free from defects in materials or workmanship for two years or 1500 operational hours*, whichever occurs first. Where a warrantable condition exists, we will repair the Product at no cost to you including diagnosis, labor, parts, and transportation. This warranty begins on the date the Product is delivered to the original retail purchaser.

* Product equipped with hour meter

Instructions for Obtaining Warranty Service

You are responsible for notifying the Commercial Products Distributor or Authorized Commercial Products Dealer from whom you purchased the Product as soon as you believe a warrantable condition exists.

If you need help locating a Commercial Products Distributor or Authorized Dealer, or if you have questions regarding your warranty rights or responsibilities, you may contact us at:

Toro Commercial Products Service Department
Toro Warranty Company
8111 Lyndale Avenue South
Bloomington, MN 55420-1196
952-888-8801 or 800-982-2740
E-mail: commercial.service@toro.com

Owner Responsibilities

As the Product owner, you are responsible for required maintenance and adjustments stated in your operator's manual. Failure to perform required maintenance and adjustments can be grounds for disallowing a warranty claim.

Items and Conditions Not Covered

Not all product failures or malfunctions that occur during the warranty period are defects in materials or workmanship. This express warranty does not cover the following:

- Product failures which result from the use of non-Toro replacement parts, or from installation and use of add-on, modified, or unapproved accessories
- Product failures which result from failure to perform required maintenance and/or adjustments
- Product failures which result from operating the Product in an abusive, negligent or reckless manner
- Parts subject to consumption through use unless found to be defective. Examples of parts which are consumed, or used up, during normal Product operation include, but are not limited to, blades, reels, bedknives, tines, spark plugs, castor wheels, tires, filters, belts, and certain sprayer components such as diaphragms, nozzles, and check valves, etc.

Countries Other than the United States or Canada

Customers who have purchased Toro products exported from the United States or Canada should contact their Toro Distributor (Dealer) to obtain guarantee policies for your country, province, or state. If for any reason you are dissatisfied with your Distributor's service or have difficulty obtaining guarantee information, contact the Toro importer. If all other remedies fail, you may contact us at Toro Warranty Company.

- Failures caused by outside influence. Items considered to be outside influence include, but are not limited to, weather, storage practices, contamination, use of unapproved coolants, lubricants, additives, or chemicals, etc.
- Normal "wear and tear" items. Normal "wear and tear" includes, but is not limited to, damage to seats due to wear or abrasion, worn painted surfaces, scratched decals or windows, etc.

Parts

Parts scheduled for replacement as required maintenance are warranted for the period of time up to the scheduled replacement time for that part.

Parts replaced under this warranty become the property of Toro. Toro will make the final decision whether to repair any existing part or assembly or replace it. Toro may use factory remanufactured parts rather than new parts for some warranty repairs.

General Conditions

Repair by an Authorized Toro Distributor or Dealer is your sole remedy under this warranty.

Neither The Toro Company nor Toro Warranty Company is liable for indirect, incidental or consequential damages in connection with the use of the Toro Products covered by this warranty, including any cost or expense of providing substitute equipment or service during reasonable periods of malfunction or non-use pending completion of repairs under this warranty. Except for the Emissions warranty referenced below, if applicable, there is no other express warranty. All implied warranties of merchantability and fitness for use are limited to the duration of this express warranty.

Some states do not allow exclusions of incidental or consequential damages, or limitations on how long an implied warranty lasts, so the above exclusions and limitations may not apply to you.

This warranty gives you specific legal rights, and you may also have other rights which vary from state to state.

Note regarding engine warranty: The Emissions Control System on your Product may be covered by a separate warranty meeting requirements established by the U.S. Environmental Protection Agency (EPA) and/or the California Air Resources Board (CARB). The hour limitations set forth above do not apply to the Emissions Control System Warranty. Refer to the Engine Emission Control Warranty Statement printed in your operator's manual or contained in the engine manufacturer's documentation for details.