



## Dethatching Reel Greensmaster® 3000 Series

Model No. 04496 - 260000001 and up.

### Parts Catalog

---

#### **Ordering Replacement Parts**

To order replacement parts, please supply the part number, the quantity, and the description of each part desired.

#### **Understanding Reference Numbers**

Each identified part in an illustration has a reference number. The reference number for a part also appears in the parts list, along with other information about the part.

This catalog uses two special reference number formats, one to indicate parts in a service assembly and another to indicate the quantity of a given part in an illustration.

#### **Service Assembly Reference Numbers**

Parts in service assemblies have reference numbers in the form a:b. The a represents the reference number of the entire service assembly and the b represents a sequential number unique to each part within the service assembly.

For example, a wheel assembly might be identified by reference number 6, the tire by 6:1, the valve by 6:2, and the wheel by 6:3. When you order the assembly identified by reference number 6, you receive all parts identified by reference numbers 6:1, 6:2, and 6:3. However, you may also order any part individually. Reference numbers of this type appear in illustrations and in part lists.

#### **Reference Numbers Indicating Quantity**

In an illustration, if a reference number indicates more than one part, the reference number has the form nX y. The n represents the quantity of the part, the X is the multiplication symbol, and the y represents the reference number.

For example, in an illustration, the reference number 2X 37 means that two of the parts identified by reference number 37 are indicated.

# Contents

Description	Page	Description	Page
Height-of-Cut Assembly	..... 3	Dethatcher Shaft Assembly	..... 5
Reel Drive Assembly	..... 4	Roll and Scraper Assembly	..... 6
		Roller Assembly No. 95-5943	..... 7

## Part Description Abbreviations

Part descriptions in this catalog may include the following abbreviations.

AR. .... as required	INC. .... incorporated
ASM. .... assembly	LH. .... left hand
BBC. .... blade brake clutch	NI. .... nylon insert
CARR. .... carriage	NPTF. .... national pipe thread fine
DEG. .... degrees	PFH. .... phillips flat head
EXT. .... external	PPH. .... phillips pan head
FH. .... flat head	PPHTF. .... phillips pan head thread forming
GA. .... gauge	PRH. .... phillips round head
HF. .... hex flange	PTH. .... phillips truss head
HH. .... hex head	PTO. .... power-take-off
HHF. .... hex head flange	RH. .... right hand
HHFTF. .... hex head flange thread forming	ROPS. .... roll-over-protection-system
HJ. .... hex jam	SFH. .... slotted fillister head
HLH. .... hex lag head	SHH. .... slotted hex head
HOC. .... height-of-cut	SHWH. .... slotted hex washer head
HSBH. .... hex socket button head	SPH. .... slotted pan head
HSFH. .... hex socket flat head	SQH. .... square head
HSH. .... hex socket head	SRH. .... slotted round head
HWH. .... hex washer head	STD. .... standard
HWHTF. .... hex washer head thread forming	TAP. .... self tapping
HYD. .... hydraulic	TTH. .... torx truss head

## Footnotes

❶ Not illustrated

❷ Not serviced separately

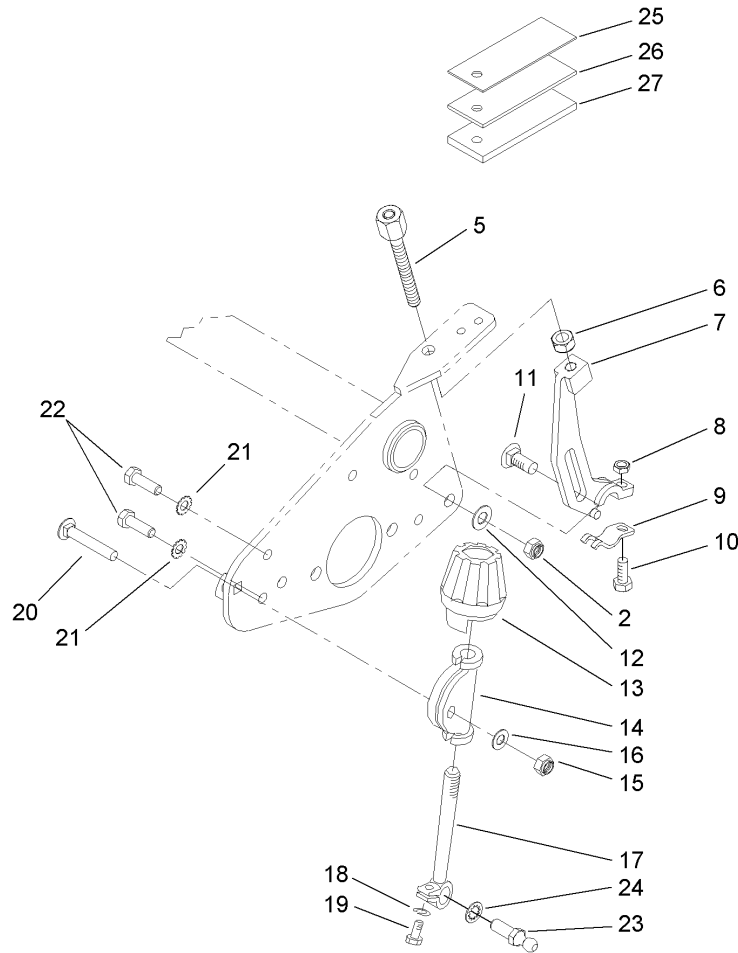

## Height-of-Cut Assembly

Ref	Part No.	Qty.	Description
2	33025-00	2	Nut-Lock
5	95-1633	2	HOC Adjust ASM
6	3296-5	2	Nut-Lock
7	95-1638	2	Bracket-Rear, HOC Adjust
8	33014-00	2	Nut-Hex
9	99-8168	2	Collar-HOC
10	33114-030	2	Screw-HH
11	33125-025	2	Screw-CARR
12	3256-24	2	Washer-Flat
13	65-8600	2	Knob-Adjustment, Height
14	10-5060	2	Bracket-HOC
15	3296-29	2	Nut-Lock, NI
16	3256-23	2	Washer-Flat
17	10-5010	2	Screw-Adjustment, Roller
18	3253-3	2	Washer-Lock
19	321-4	2	Screw-HH
20	3-7253	2	Bolt-Carriage
21	3255-8	4	Washer-Lock
22	322-5	4	Screw-HH
23	94-2958	2	Stud-Ball
24	3254-6	2	Washer-Lock, Internal
25	99-8189	1	Plate-Gauge,.060
26	99-8188	1	Plate-Gauge,.120
27	99-8187	1	Plate-Gauge,.250

--	--	--	--

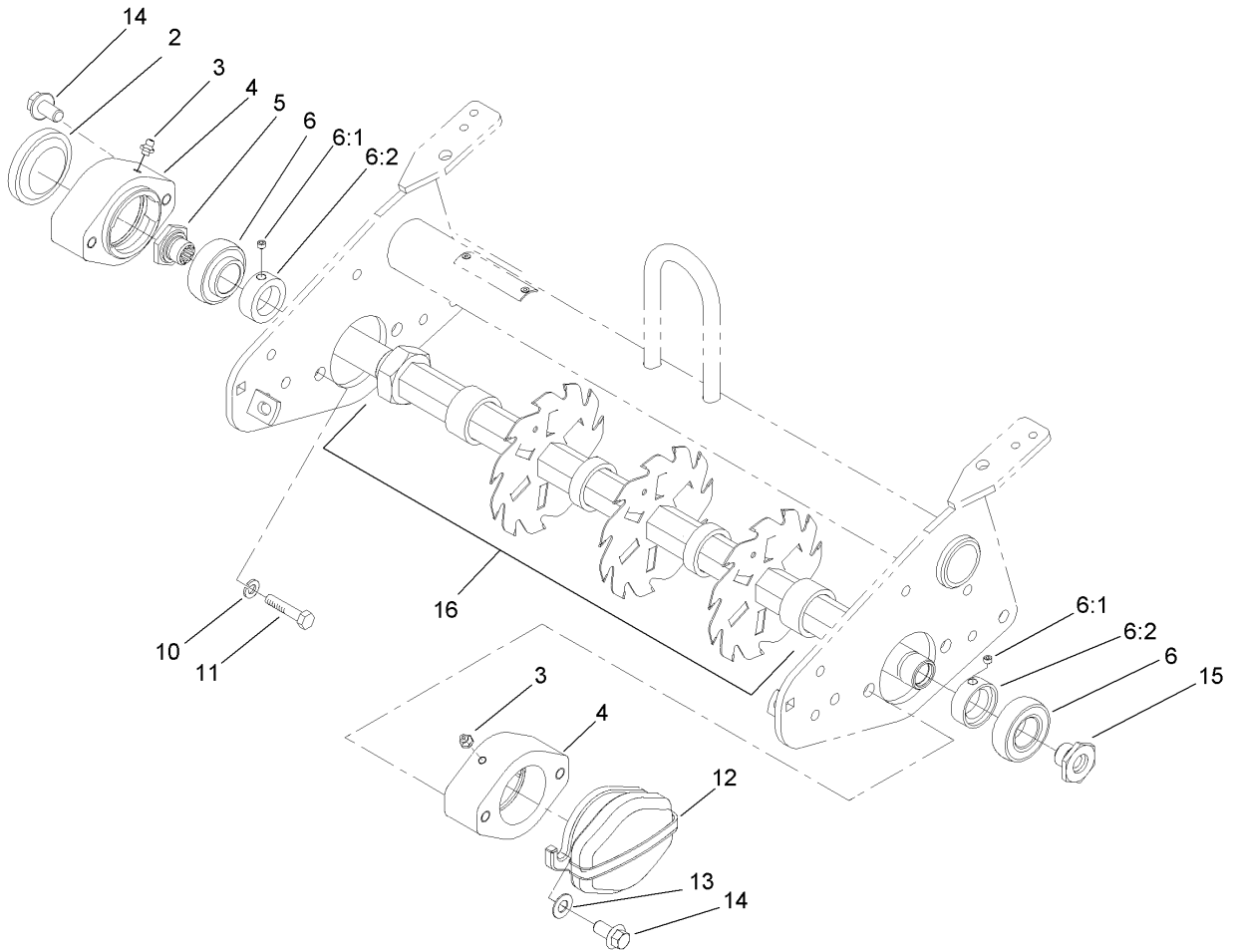

## Reel Drive Assembly

Ref	Part No.	Qty.	Description	
2	2410-30	1	Cap-Plastic	
3	302-5	2	Fitting-Grease	
4	95-7148	2	Housing-Bearing	
5	93-1394	1	Nut-Spline	
6	94-3405	2	Bearing-Ball	
6:1	3245-35	1	Screw-Set	
6:2	251-77	1	Lockcollar-Bearing	
10	48-9590	4	Washer-Lock	
11	33115-025	4	Screw-HH	
12	95-1642-01	1	Weight-Counter	
13	3256-24	2	Washer-Flat	
14	93-2569	4	Screw-HHF	
15	94-9214	1	Nut-Spline, LH	
16		1	Dethatcher Shaft ASM	



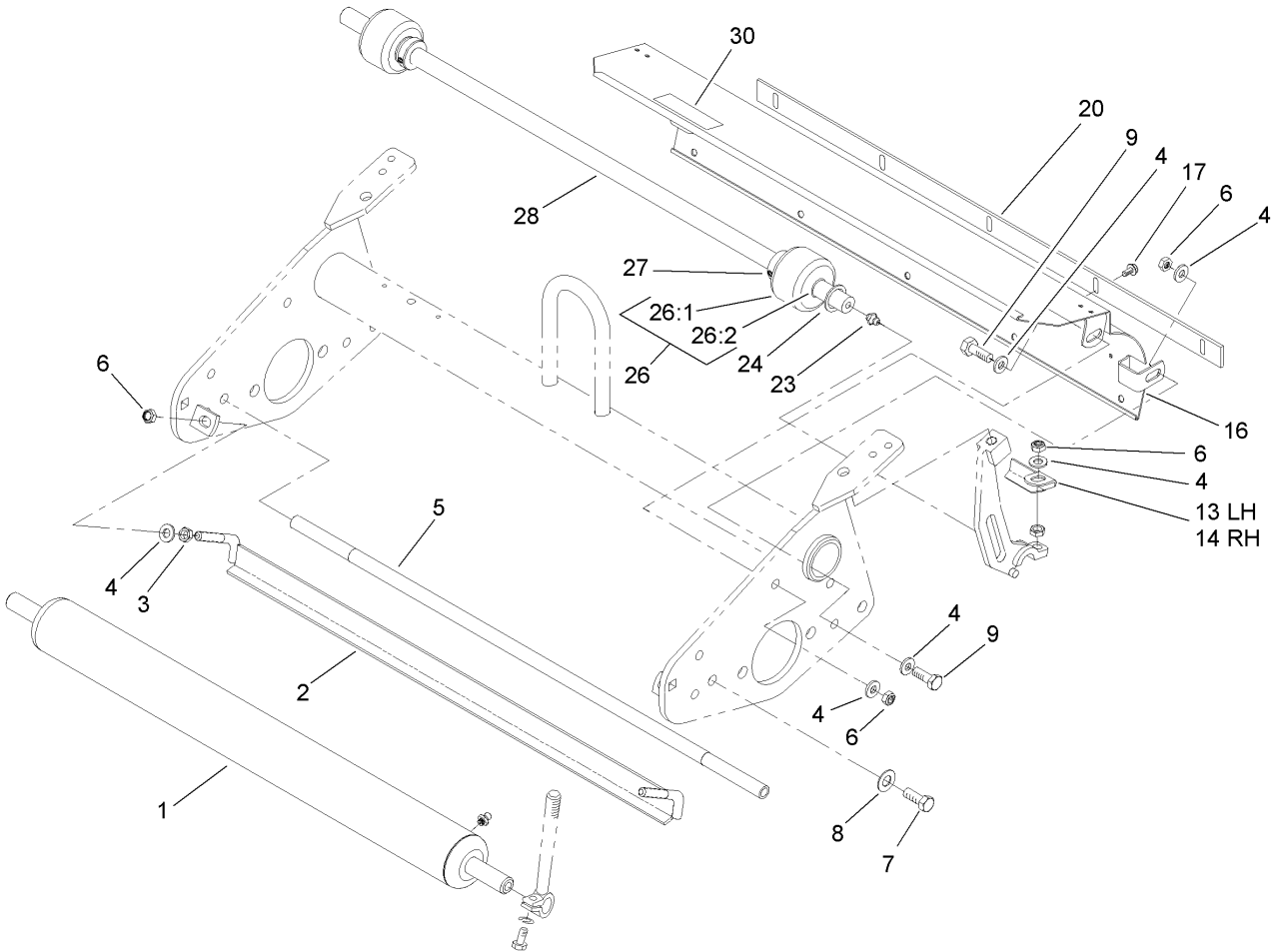

## Roll and Scraper Assembly

Ref	Part No.	Qty.	Description
1	95-5943	1	Roller ASM
2	94-9226	1	Bracket-Scraper
3	33014-00	2	Nut-Hex
4	3256-74	12	Washer-Flat
5	98-2196	1	Rod-Shield
6	33024-00	8	Nut-Lock
7	33115-020	2	Screw-HH
8	3256-24	2	Washer-Flat
9	33114-020	4	Screw-HH
13	94-9220	1	Scraper-Roller, LH
14	94-9219	1	Scraper-Roller, RH
16	98-3551	1	Grass Shield ASM
17	104-2065	5	Screw-HWH
20	36-7260	1	Bar-Off, Cut
23	302-5	2	Fitting-Grease
24	257-11	4	Washer-Thrust
26		2	Wheel / Bearing ASM
26:1	94-9211	1	Wheel ASM
26:2	95-7497	2	Bushing-Wheel
27	94-9213	2	Collar-Shaft
28	94-9210	1	Shaft-Wheel, Rear
30	93-6688	1	Decal-Danger, Europe

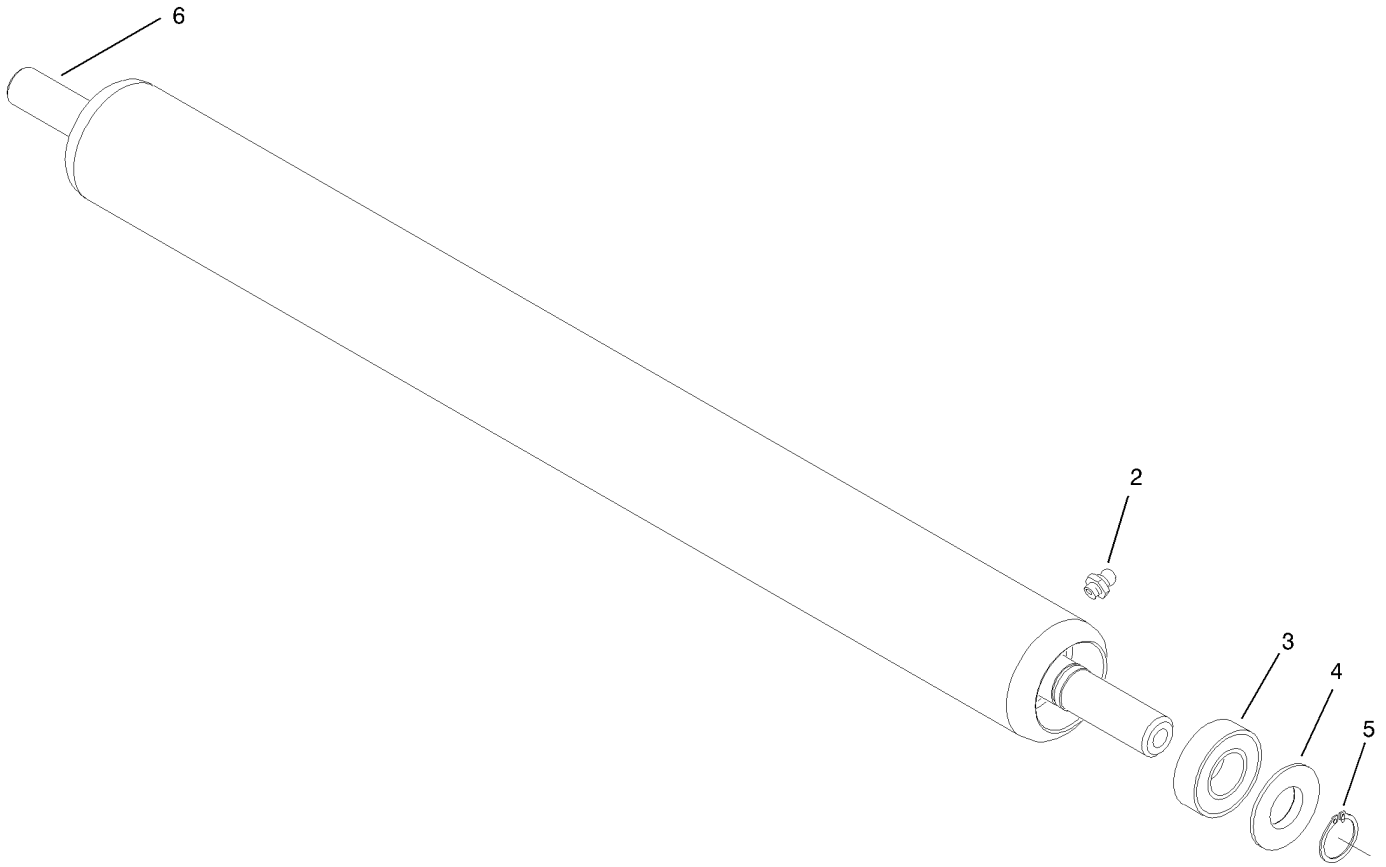
### Roller Assembly No. 95-5943

Ref	Part No.	Qty.	Description
2	302-5	2	Fitting-Grease
3	85-9970	2	Bearing-Ball
4	85-7190	2	Washer-Shield
5	32151-12	2	Ring-Retaining
6	95-5946	1	Shaft-Roller

