



## Z597-D Z Master<sup>®</sup> With 72in TURBO FORCE<sup>®</sup> Side Discharge Mower

Model No. 74269 - 260000001 and up.

### Parts Catalog

---

#### Ordering Replacement Parts

To order replacement parts, please supply the part number, the quantity, and the description of each part desired.

#### Understanding Reference Numbers

Each Identified part in an illustration has a reference number. The reference number for a part also appears in the parts list, along with other information about the part.

This catalog uses two special reference number formats, one to indicate parts in a service assembly and another to indicate the quantity of a given part in an illustration.

#### Service Assembly Reference Numbers

Parts in service assemblies have reference numbers in the form a:b. The a represents the reference number of the entire service assembly and the b represents a sequential number unique to each part within the service assembly.

For example, a wheel assembly might be identified by reference number 6, the tire by 6:1, the valve by 6:2, and the wheel by 6:3. When you order the assembly identified by reference number 6, you receive all parts identified by reference numbers 6:1, 6:2, and 6:3. However, you may also order any part individually. Reference numbers of this type appear in illustrations and in part lists.

#### Reference Numbers Indicating Quantity

In an illustration, if a reference number indicates more than one part, the reference number has the form nX y. The n represents the quantity of the part, the X is the multiplication symbol, and the y represents the reference number.

For example, in an illustration, the reference number 2X 37 means that two of the parts identified by reference number 37 are indicated.

# Contents

Description	Page	Description	Page
Front Frame Assembly	..... 3	Hood Assembly	..... 23
Caster and Z Stand Assembly	..... 5	Deck Connection Assembly	..... 24
Engine Frame, Console and Floor Pan Assembly	..... 6	Deck Assembly	..... 25
Seat and Roll-Over-Protection-System Assembly	..... 7	Deck Decal Assembly No. 107-7677	..... 27
Deluxe Seat Assembly No. 110-0838	..... 8	Spindle Assembly No. 106-3217	..... 28
Roll-Over-Protection-System Assembly No. 106-7437	..... 9	Lever Assembly No. 107-1664	..... 29
Wheel and Brake Assembly	..... 10	Rubber Deflector Assembly No. 108-2792	..... 30
Motion Control Assembly	..... 11	Electrical Component Assembly	..... 31
Engine Mount Assembly	..... 12	Cylinder Assembly	..... 33
Wheel Pump Drive Assembly	..... 13	Crankshaft Assembly	..... 34
Deck Belt Drive Assembly	..... 14	Cylinder Head Assembly	..... 35
Cooling Pump Drive Assembly	..... 15	Injection Pump Assembly	..... 36
Hydraulic System Assembly	..... 16	Camshaft Assembly	..... 37
Tank and Fuel Line Assembly	..... 18	Oil Pan Assembly	..... 38
Front and Rear Engine Cover Assembly	..... 20	Gear Cover Assembly	..... 39
Cooling System Assembly	..... 22	Gear Housing Assembly	..... 40
		Water Pump Assembly	..... 41
		Manifold Assembly	..... 42
		Starter Motor and Alternator Assembly	..... 43
		Gasket Assembly	..... 44

## Part Description Abbreviations

Part descriptions in this catalog may include the following abbreviations.

AR. .... as required	INC. .... incorporated
ASM. .... assembly	LH. .... left hand
BBC. .... blade brake clutch	NI. .... nylon insert
CARR. .... carriage	NPTF. .... national pipe thread fine
DEG. .... degrees	PFH. .... phillips flat head
EXT. .... external	PPH. .... phillips pan head
FH. .... flat head	PPHTF. .... phillips pan head thread forming
GA. .... gauge	PRH. .... phillips round head
HF. .... hex flange	PTH. .... phillips truss head
HH. .... hex head	PTO. .... power-take-off
HHF. .... hex head flange	RH. .... right hand
HHFTF. .... hex head flange thread forming	ROPS. .... roll-over-protection-system
HJ. .... hex jam	SFH. .... slotted fillister head
HLH. .... hex lag head	SHH. .... slotted hex head
HOC. .... height-of-cut	SHWH. .... slotted hex washer head
HSBH. .... hex socket button head	SPH. .... slotted pan head
HSFH. .... hex socket flat head	SQH. .... square head
HSH. .... hex socket head	SRH. .... slotted round head
HWH. .... hex washer head	STD. .... standard
HWHTF. .... hex washer head thread forming	TAP. .... self tapping
HYD. .... hydraulic	TTH. .... torx truss head

## Footnotes

❶ Not illustrated

❷ Not serviced separately

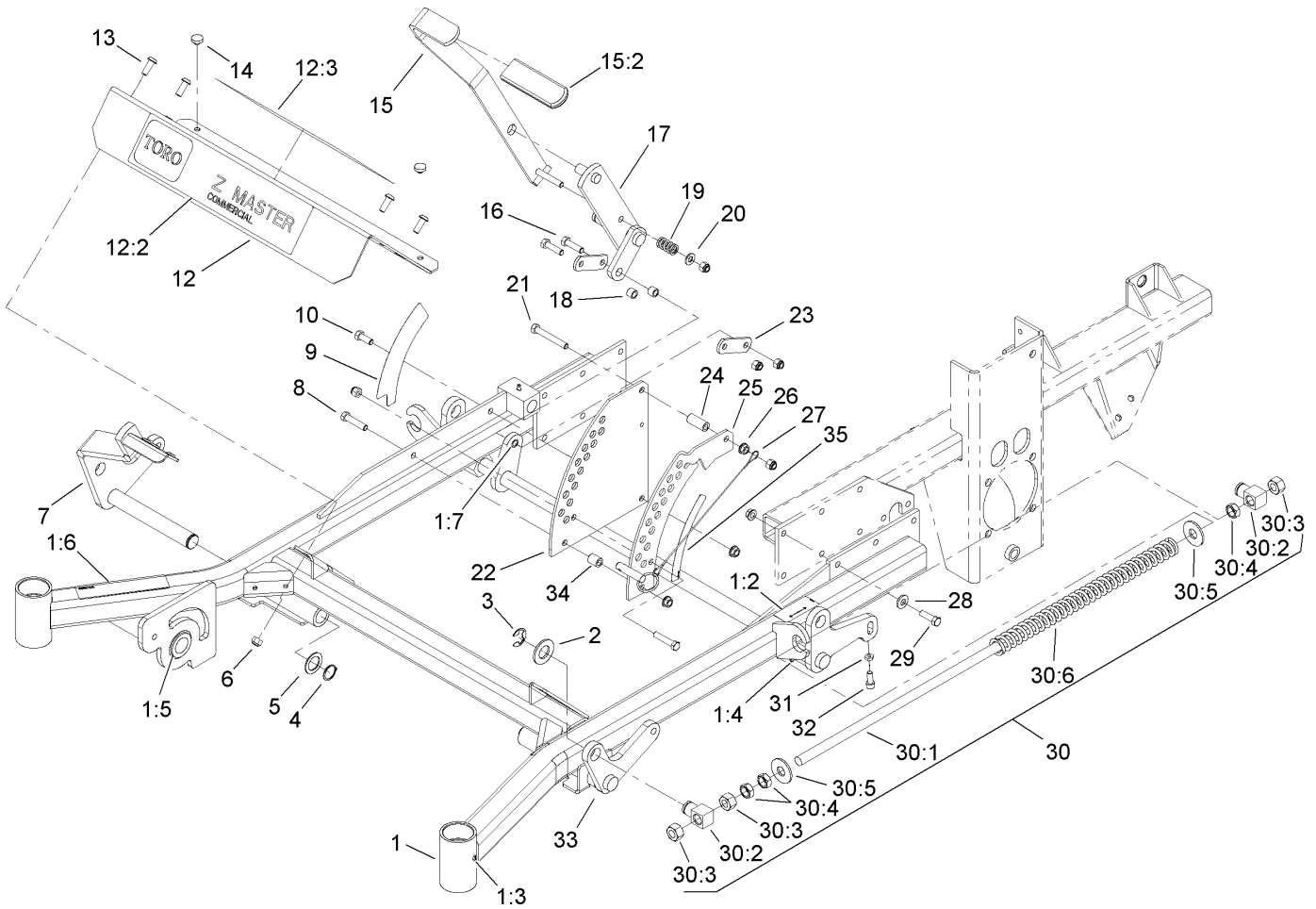

## Front Frame Assembly

Ref	Part No.	Qty.	Description
1	106-8999	1	Frame ASM
1:2	107-1857	1	Decal-Brake, Parking
1:3	1-811010	2	Plug
1:4	302-19	5	Fitting-Grease
1:5	94-1291	2	Bushing
1:6	104-7759	1	Decal-Warning
1:7	103-1918	1	Bushing
2	3256-29	4	Washer-Flat
3	32151-103	5	Ring-Snap
4	32151-29	2	Ring-Retaining
5	1-523157	2	Washer-Spacer
6	3296-39	9	Nut-Lock, NI
7	106-8983-01	1	RH Deck Lift ASM
8	323-9	2	Screw-HH
9	107-1860	1	Decal-Height, Deck
10	323-6	1	Screw-HH
12	106-9981	1	Front Floorpan ASM
12:2	106-7451	1	Decal
12:3	107-2112	1	Decal-Warning
13	3274-94	4	Screw-HSBH
14	1-513658	2	Bumper
15	103-2084	1	Lift Lever/Grip ASM
15:2	1-633295	1	Grip-Lever, Lift
16	323-29	2	Screw-HH

Ref	Part No.	Qty.	Description
17	103-2064-03	1	Arm-Lift, Deck
18	103-1918	2	Bushing
19	1-633325	1	Spring-Compression
20	3256-24	1	Washer-Flat
21	323-13	1	Screw-HH
22	1-633889-01	1	Plate-Lift, Deck
23	1-633068	2	Arm-Lift, Deck
24	1-633082	1	Bushing-Lever, Lift
25	108-7759-01	1	Plate-Lift, Deck
26	3290-357	15	Nut-HHF, Whiz
27	106-9951	1	Hitch Pin ASM
28	98-5975	12	Washer-Belleville
29	323-7	12	Screw-HH
30		2	Front Frame Spring ASM
30:1	1-633096	1	Rod-Lift, Deck
30:2	1-633441	2	Swivel-Deck Mount, Rear
30:3	3217-11	3	Nut-Hex
30:4	3218-6	3	Nut-Jam
30:5	3256-7	2	Washer-Flat
30:6	1-643015	1	Spring-Support, Deck
31	3218-2	2	Nut-Jam
32	3274-18	2	Screw-HSH
33	106-8984-01	1	LH Deck Lift ASM
34	1-633080	1	Bushing-Lever, Lift



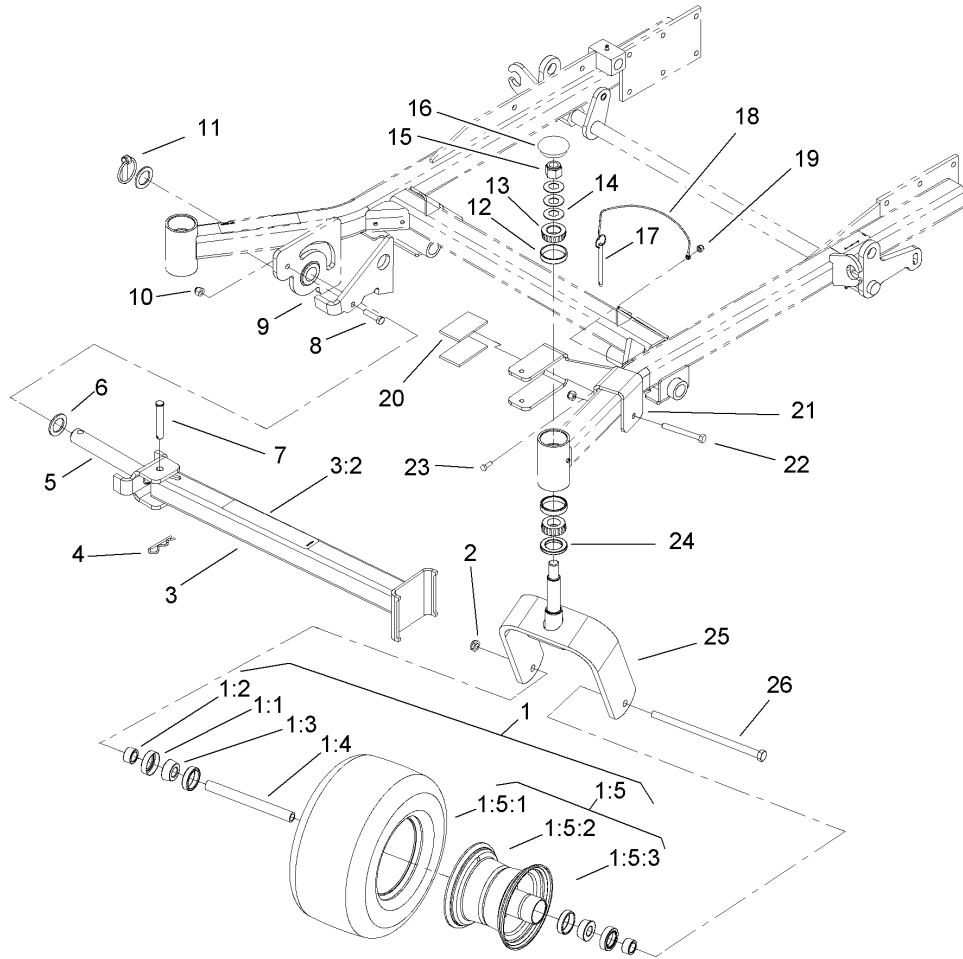

## Caster and Z Stand Assembly

Ref	Part No.	Qty.	Description
1	1-644251	2	Caster Wheel ASM
1:1	1-633580	2	Seal-Bearing
1:2	1-633581	2	Spacer-Bearing
1:3	1-633585	2	Bearing-Cone, Taper
1:4	1-633959	1	Spacer-Caster, Front
1:5	1-523009	1	Wheel And Tire ASM
1:5:1	1-523009	1	Tire
1:5:2	1-633987	1	Wheel
1:5:3	1-633584	2	Bearing-Cup
2	3296-23	2	Nut-Lock, NI
3	107-1874	1	Leg ASM
3:2	106-7464	1	Decal-Z Stand
4	3290-355	1	Pin-Hair
5	100-9692-01	1	Pivot Pin ASM
6	3-6781	2	Washer-Thrust
7	283-55	1	Pin-Clevis
8	323-8	1	Screw-HH
9	100-9686-01	1	Bracket-Latch
10	3296-39	2	Nut-Lock, NI
11	283-71	1	Pin-Lynch
12	254-72	4	Bearing-Cup, Tapered
13	254-94	4	Bearing-Cone, Tapered
14	1-633508	6	Washer-Bellville
15	3296-51	2	Nut-Lock, NI

Ref	Part No.	Qty.	Description
16	103-4882	2	Cap-Grease
17	105-1647	1	Pin-Hitch, Cotterless
18	100-9385	1	Lanyard-Nylon
19	3296-42	1	Nut-Lock, NI
20	100-6547	2	Cushion-Rubber
21	100-6542-01	1	Bracket-Cradle
22	323-20	1	Screw-HH
23	321-4	1	Screw-HH
24	1-543511	2	Seal-Grease
25	103-1474-01	2	Fork-Caster
26	325-39	2	Screw-HH

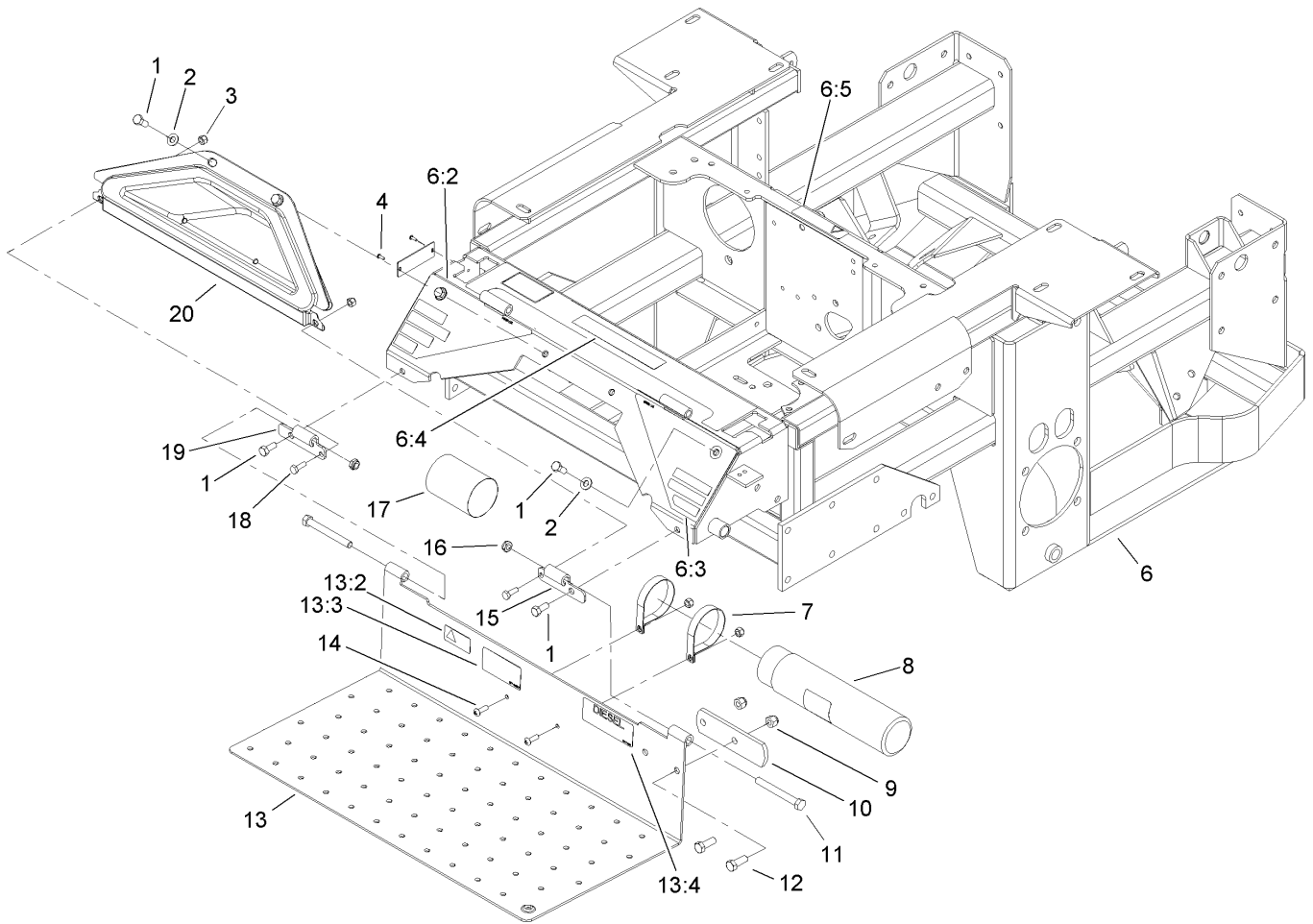

## Engine Frame, Console and Floor Pan Assembly

Ref	Part No.	Qty.	Description
1	322-43	6	Screw-HH
2	3256-70	4	Washer-Flat
3	3296-42	4	Nut-Lock, NI
4	923786	2	Rivet
6	107-7699	1	Main Frame ASM
6:2	106-9989	1	Decal-Warning
6:3	106-7492	1	Decal-Danger
6:4	107-9866	1	Decal-Console, Top
6:5	98-5954	2	Decal-Missing, Cover
7	107-1865	2	R-Clamp
8	104-7050	1	Housing-Manual
9	3296-39	2	Nut-Lock, NI
10	1-633964-03	1	Stop-Brake, Park
11	323-20	2	Screw-HH
12	323-6	2	Screw-HH
13	107-7697	1	Floor Pan ASM
13:2	98-4387	1	Decal-Protection, Ear
13:3	107-1864	1	Decal-Location, Manual
13:4	107-7666	1	Decal-Diesel
14	3258-166	2	Screw-PRH
15	106-7488-03	1	Hinge-Floorpan, LH
16	3296-59	2	Nut-Lock, NI
17	104-7048	1	Cap-Housing
18	321-4	2	Screw-HH

Ref	Part No.	Qty.	Description
19	106-7489-03	1	Hinge-Floorpan, RH
20	106-7498	1	Pocket

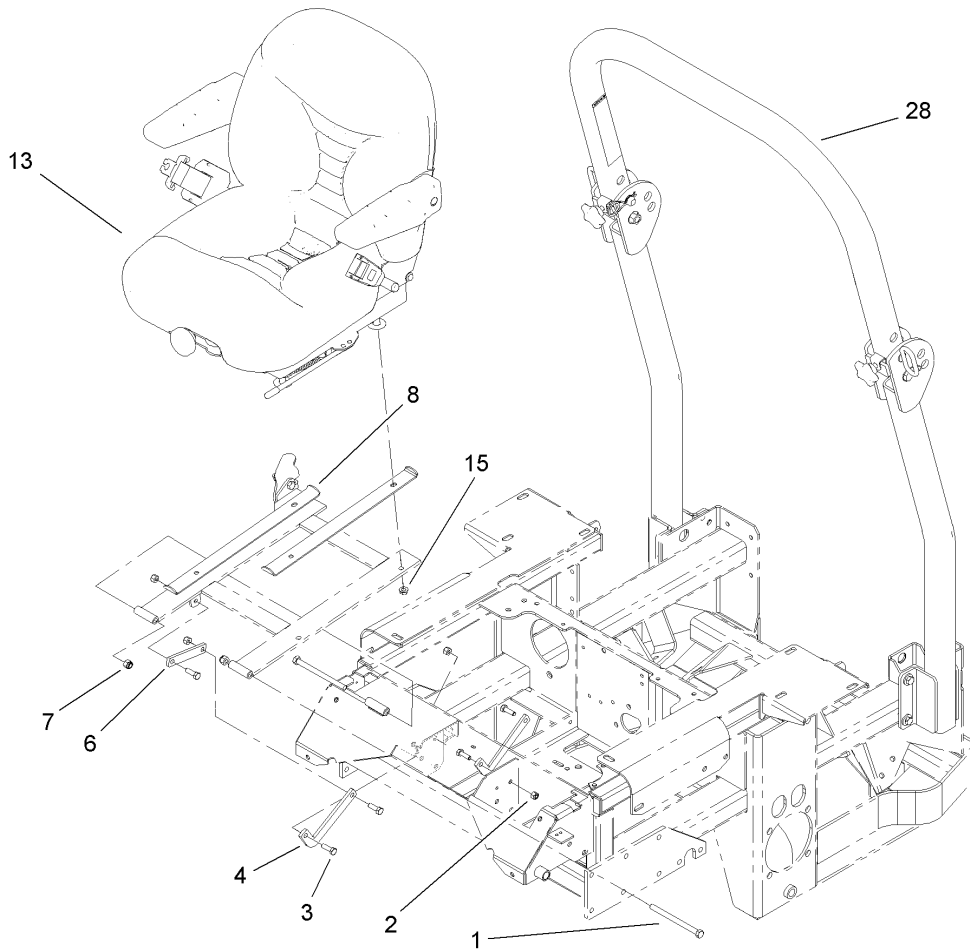

## Seat and Roll-Over-Protection-System Assembly

Ref	Part No.	Qty.	Description
1	323-39	2	Screw-HH
2	3296-29	4	Nut-Lock, NI
3	322-5	5	Screw-HH
4	103-5181	2	Link-Seat Stop, Lower
6	103-5161	2	Link-Stop, Seat
7	3296-39	2	Nut-Lock, NI
8	1-633872-03	2	Stop-Seat
13	110-0838	1	Deluxe Seat ASM
15	32128-20	4	Nut-HF
28	106-7437	1	ROPS ASM

--	--	--	--

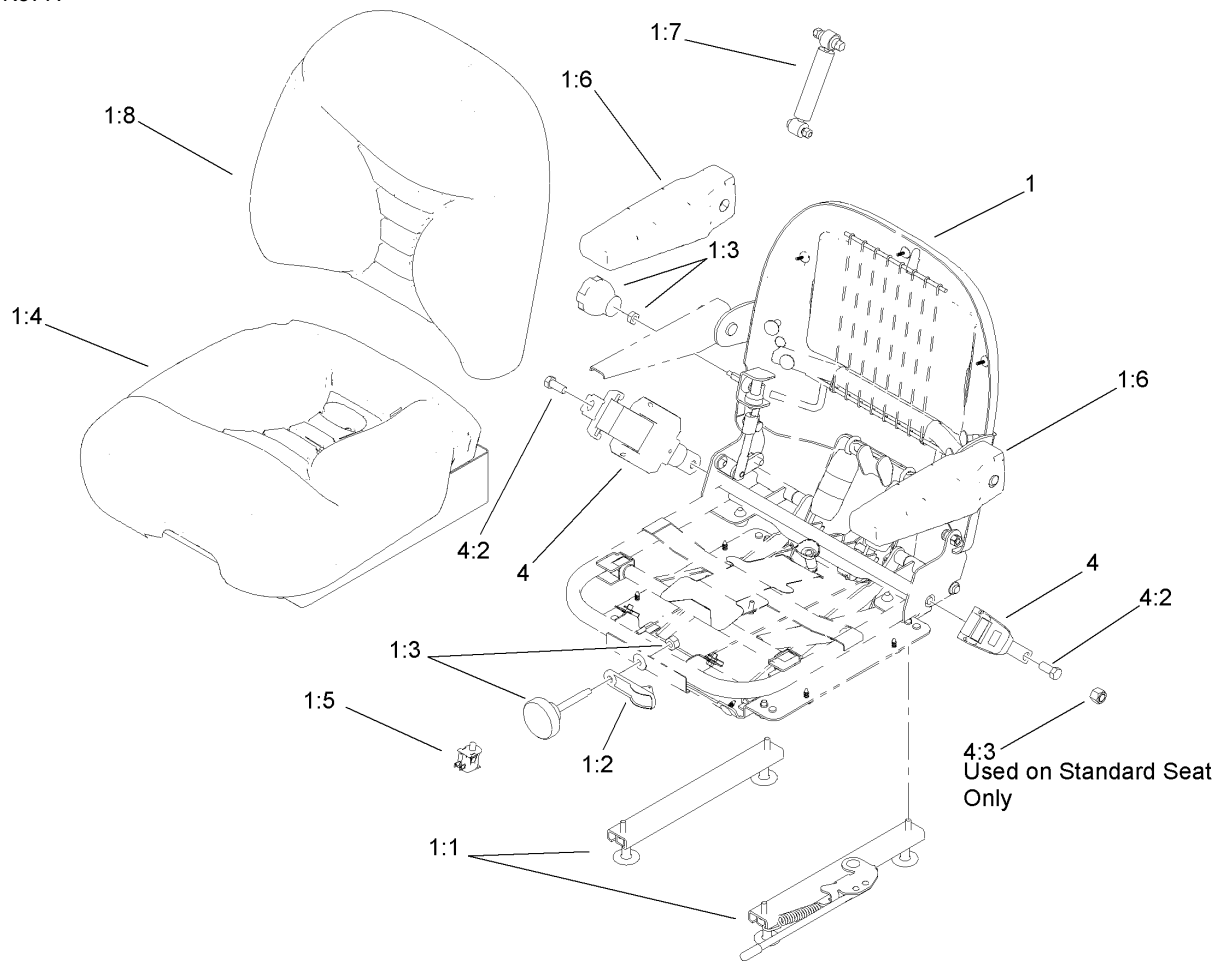

## Deluxe Seat Assembly No. 110-0838

Ref	Part No.	Qty.	Description
1		1	Seat ASM
1:1	107-1880	1	Seat Track Kit
1:2	107-1885	1	Weight Indicator Kit
1:3	107-1881	1	Knob Kit
1:4	107-1883	1	Bottom Cushion Kit
1:5	107-1886	1	Switch Kit
1:6	107-1887	1	Armrest Kit
1:7	107-1884	1	Shock Absorber Kit
1:8	107-1882	1	Back Cushion Kit
4	110-0883	1	Retractable Seatbelt Kit
4:2	3212-4	2	Screw-HH
4:3	3296-7	2	Nut-Lock

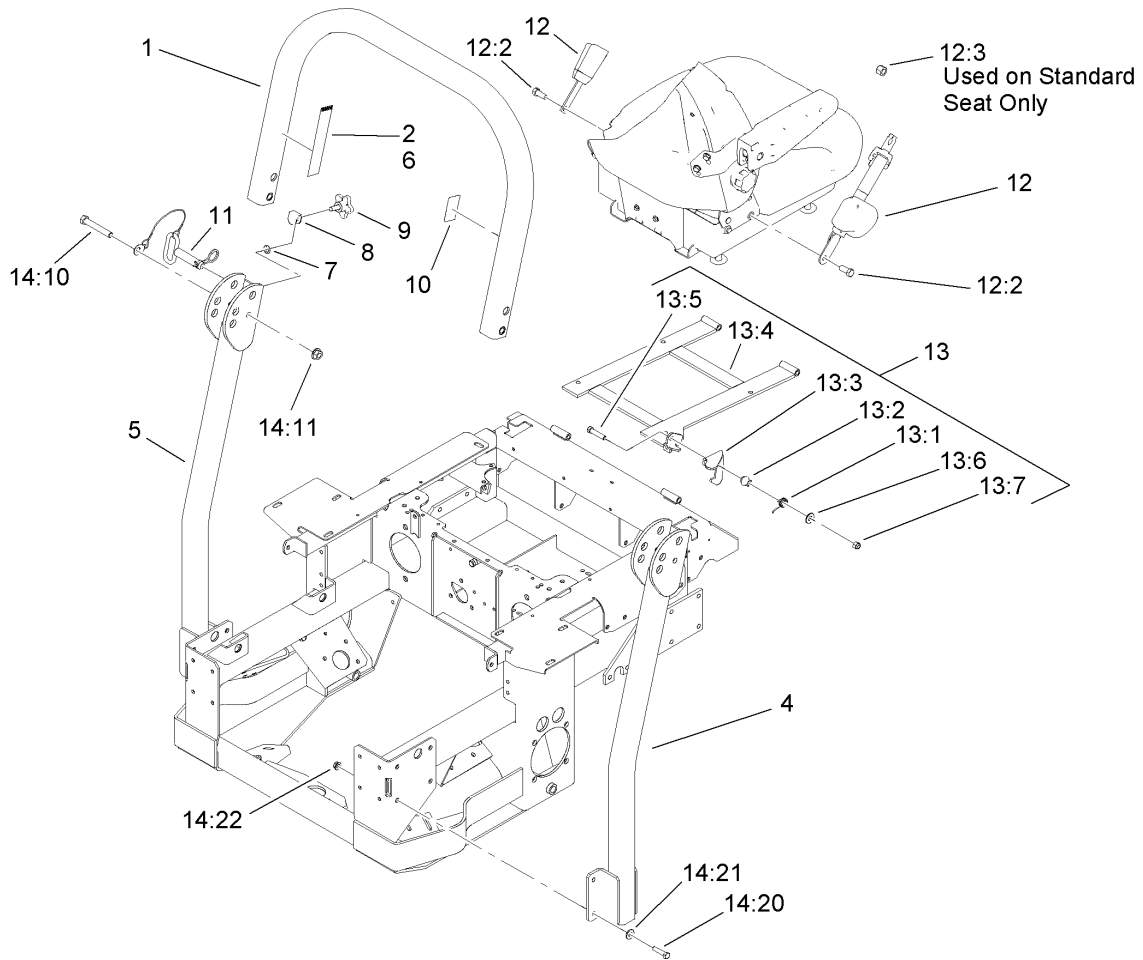

## Roll-Over-Protection-System Assembly No. 106-7437

Ref	Part No.	Qty.	Description
② 1		1	Upper Tube ASM
2	107-2102	1	Decal-Warning, Folding ROPS
② 4		1	Tube-Support, RH
② 5		1	Tube-Support, LH
6	107-3069	1	Decal-Warning, Folding ROPS (Ce)
7	107-3154	2	Nut-Push
8	107-3124	2	Clip
9	106-0887	2	Knob
10	107-2101	1	Decal-ROPS
11	103-4553	2	ROPS Fold Pin ASM
12	110-0883	1	Retractable Seatbelt Kit
12:2	3212-4	2	Screw-HH
12:3	3296-7	2	Nut-Lock
13	103-5537	1	Seat Frame ASM
13:1	103-5519	1	Spring-Torsion, Latch
13:2	107-0075	1	Bushing-Latch, Seat
13:3	103-5520	1	Catch-Latch, Single
13:4	103-7967-03	1	Seat Frame ASM
13:5	323-9	1	Screw-HH
13:6	3256-4	1	Washer-Flat
13:7	3296-39	1	Nut-Lock, NI
① ② 14		1	Bag-Bolt
14:10	325-13	2	Screw-HH

Ref	Part No.	Qty.	Description
14:11	32128-23	2	Nut-HF
14:20	323-8	8	Screw-HH
14:21	98-5975	8	Washer-Belleville
14:22	3290-357	8	Nut-HHF, Whiz

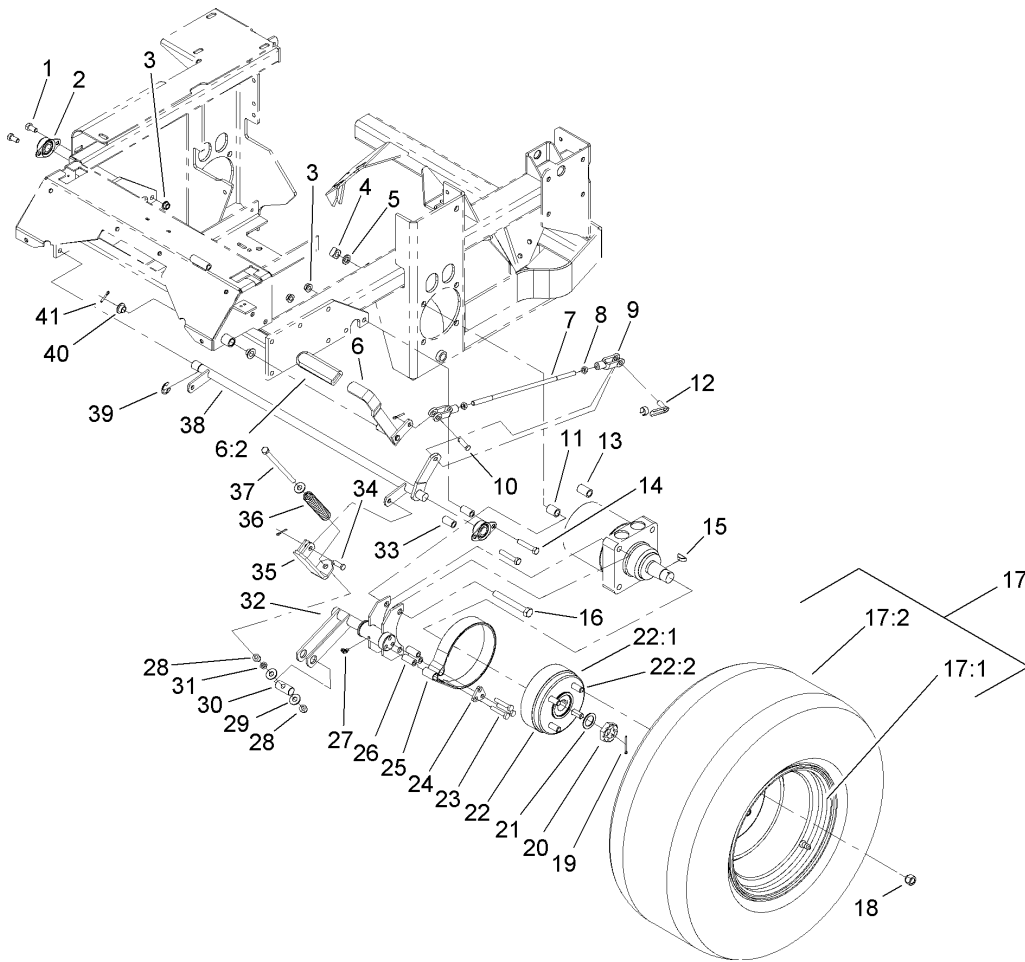

## Wheel and Brake Assembly

Ref	Part No.	Qty.	Description
1	323-4	2	Screw-HH
2	1-633102	2	Bearing-Flange, Side
3	3290-357	4	Nut-HHF, Whiz
4	103-0131	8	Nut-Square
5	3253-7	8	Washer-Lock
6	103-0197	1	Brake Lever And Grip ASM
6:2	1-633268	1	Grip-Lever, Brake
7	103-1708	1	Rod-Brake
8	3219-3	2	Nut-Hex
9	1-633131	2	Yoke-Linkage, Brake
10	1-808285	1	Pin-Clevis
11	1-633060	4	Spacer-Wheel, Short
12	103-2399	1	Pin-Spring, Clevis
13	1-633062	4	Spacer-Wheel, Long
14	323-10	2	Screw-HH
15	3257-42	2	Key-Woodruff
16	325-20	8	Screw-HH
17	103-4962	2	Wheel And Tire ASM
17:1	1-633992	1	Wheel
17:2	103-4963	1	Tire
18	242-50	8	Nut-Lug
19	1-806800	2	Pin-Cotter
20	1-809036	2	Nut-HH
21	1-523157	2	Washer-Spacer

Ref	Part No.	Qty.	Description
22	103-0590	2	Hub And Wheel ASM
22:1	103-0589	1	Wheel Hub ASM
22:2	1-633926	4	Stud-Wheel
23	322-9	6	Screw-HH
24	103-0374	2	Retainer-Band, Brake
25	103-0355	2	Band-Brake
26	103-0384	6	Spacer
27	302-19	2	Fitting-Grease
28	3296-39	4	Nut-Lock, NI
29	3256-4	6	Washer-Flat
30	1-633144	2	Pin-Trunion
31	3218-3	2	Nut-Jam
32	103-0810-03	2	Brake-Wide
33	103-0051	2	Spacer-Retainer, Brake
34	1-808284	2	Pin-Clevis
35	103-1117-03	2	Linkage-Brake, Lower
36	1-633454	2	Spring-Brake
37	323-58	2	Bolt-TAP, HH
38	103-5243-03	1	Shaft-Brake
39	32151-48	1	E-Ring
40	1-513140	2	Bearing-Control
41	3272-10	4	Pin-Cotter

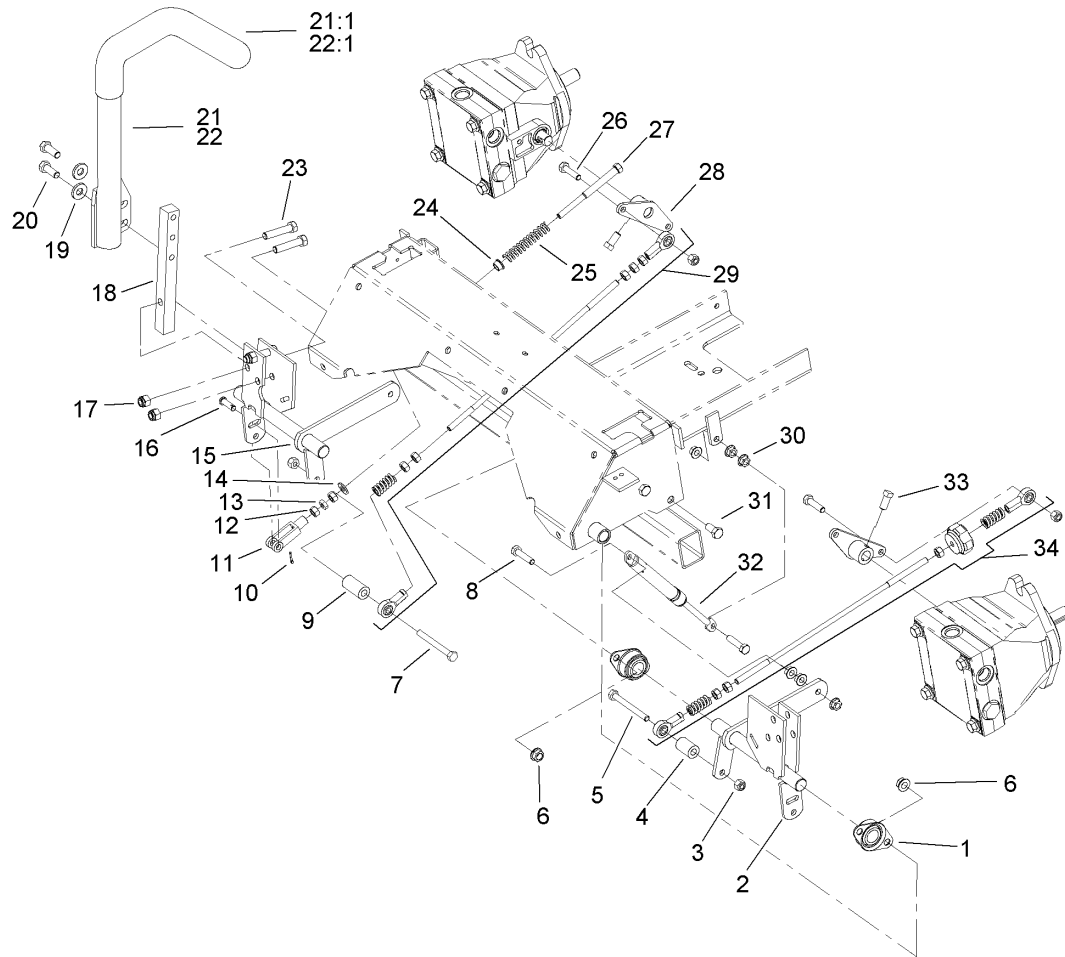

## Motion Control Assembly

Ref	Part No.	Qty.	Description	Ref	Part No.	Qty.	Description
1	1-633102	4	Bearing-Flange, Side	23	323-9	6	Screw-HH
2	103-4787	1	Control-Motion, LH	24	1-603735	2	Bushing-Flanged
3	3296-29	4	Nut-Lock, NI	25	1-603807	2	Spring-Return, Neutral
4	103-1361	1	Spacer-Hydro Control, LH	26	322-6	4	Screw-HH
5	322-12	1	Screw-HH	27	1-603737	2	Bolt-Return, Neutral
6	3290-357	8	Nut-HHF, Whiz	28	103-0194-03	2	Arm-Control, Hydro
7	322-14	1	Screw-HH	29	103-5190	1	RH HYD Connect Link ASM
8	1-403180	4	Screw-HH	30	32128-20	12	Nut-HF
9	103-5192	1	Spacer-Control, HYD	31	323-4	8	Screw-HH
10	3272-5	2	Pin-Cotter	32	103-4079	2	Damper-Control, Motion
11	1-303105	2	Yoke-Adjustable	33	1-803022	2	Screw-Set
12	3219-2	4	Nut-Hex	34	103-3062	1	Tracking Rod ASM
13	3220-2	2	Nut-Jam				
14	3256-2	2	Washer-Flat				
15	103-4788	1	Control-Motion, RH				
16	1-808280	2	Pin-Clevis				
17	3296-39	6	Nut-Lock, NI				
18	103-0407	2	Arm-Shaft, Control				
19	98-5975	4	Washer-Belleville				
20	323-6	4	Screw-HH				
21	108-7237	1	RH Lever ASM				
21:1	106-9987	1	Grip-Control, Motion				
22	108-7238	1	LH Lever ASM				
22:1	106-9987	1	Grip-Control, Motion				

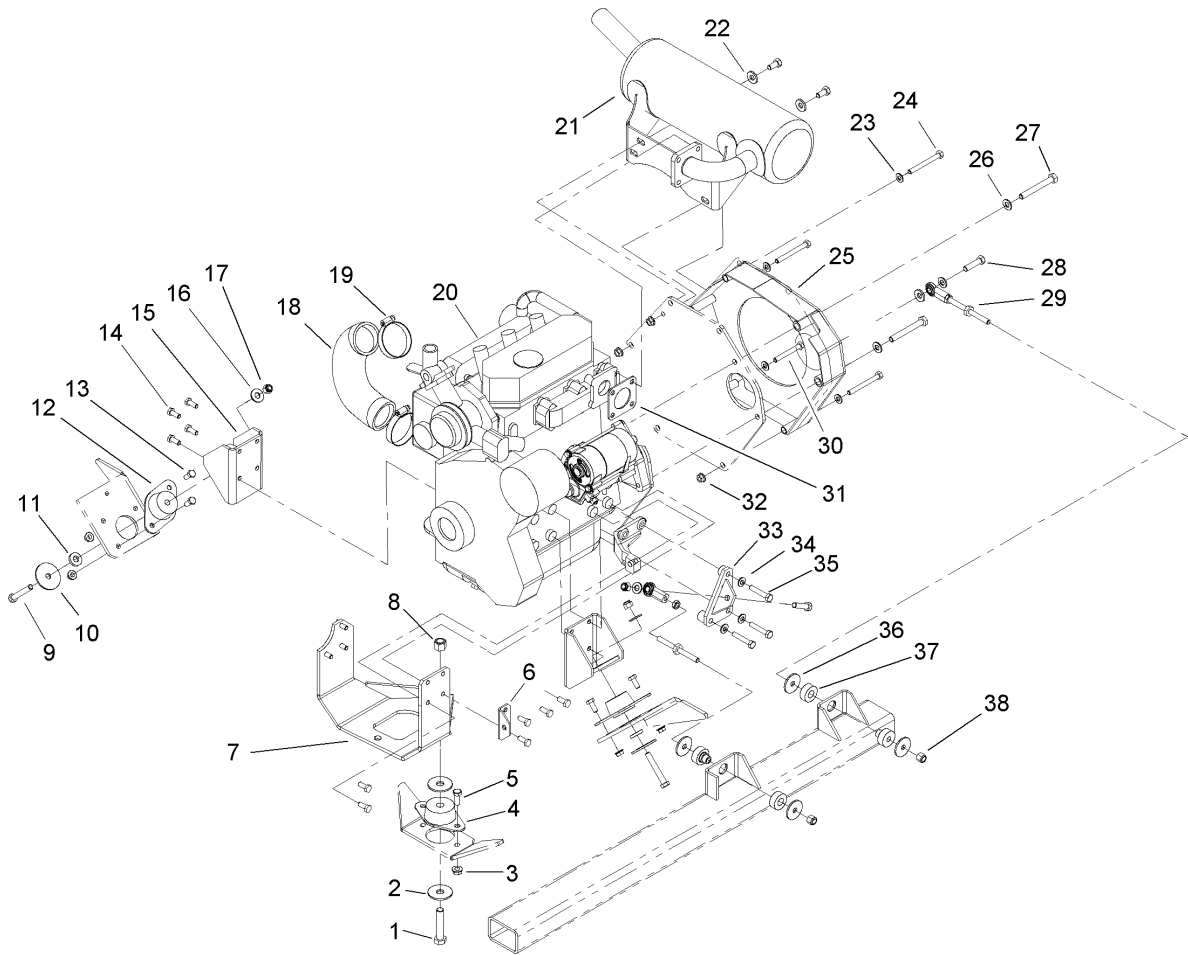

## Engine Mount Assembly

Ref	Part No.	Qty.	Description
1	325-10	1	Screw-HH
2	86-1990	2	Washer
3	3290-357	2	Nut-HHF, Whiz
4	103-1022	1	Isolator-Rear
5	323-5	2	Screw-HH
6	103-3908	1	Bracket-Ground
7	103-0870-03	1	Rear Engine Mount ASM
8	3296-23	1	Nut-Lock, NI
9	323-12	2	Screw-HH
10	83-1040	2	Washer-Flat
11	66-6480	2	Washer
12	103-2613	2	Isolator-Side
13	322-3	4	Screw-HH
14	33114-020	15	Screw-HH
15	103-0839-03	2	LH And RH Engine Mount ASM
16	3256-4	2	Washer-Flat
17	3296-39	3	Nut-Lock, NI
18	103-0921	1	Hose
19	2412-42	2	Clamp-Hose
20	103-0888	1	Engine-Daihatsu
21	103-2592	1	Muffler Kit
22	98-5975	3	Washer-Belleville
23	3256-23	4	Washer-Flat
24	322-14	3	Screw-HH

Ref	Part No.	Qty.	Description
25	103-3573-03	1	Cover-Flywheel
26	3256-24	4	Washer-Flat
27	56-2150	2	Screw-HH
28	323-8	2	Screw-HH
29	103-3745	2	Ball Joint Link ASM
30	322-12	1	Screw-HH
31	103-1385	1	Gasket-Muffler
32	32128-20	7	Nut-HF
33	103-3556-03	1	Bracket-Engine, Front
34	1-303334	3	Washer-Spring
35	33114-045	3	Screw-HH
36	93-6099	4	Washer
37	103-3568	2	Isolator-Link
38	3296-6	2	Nut-Lock

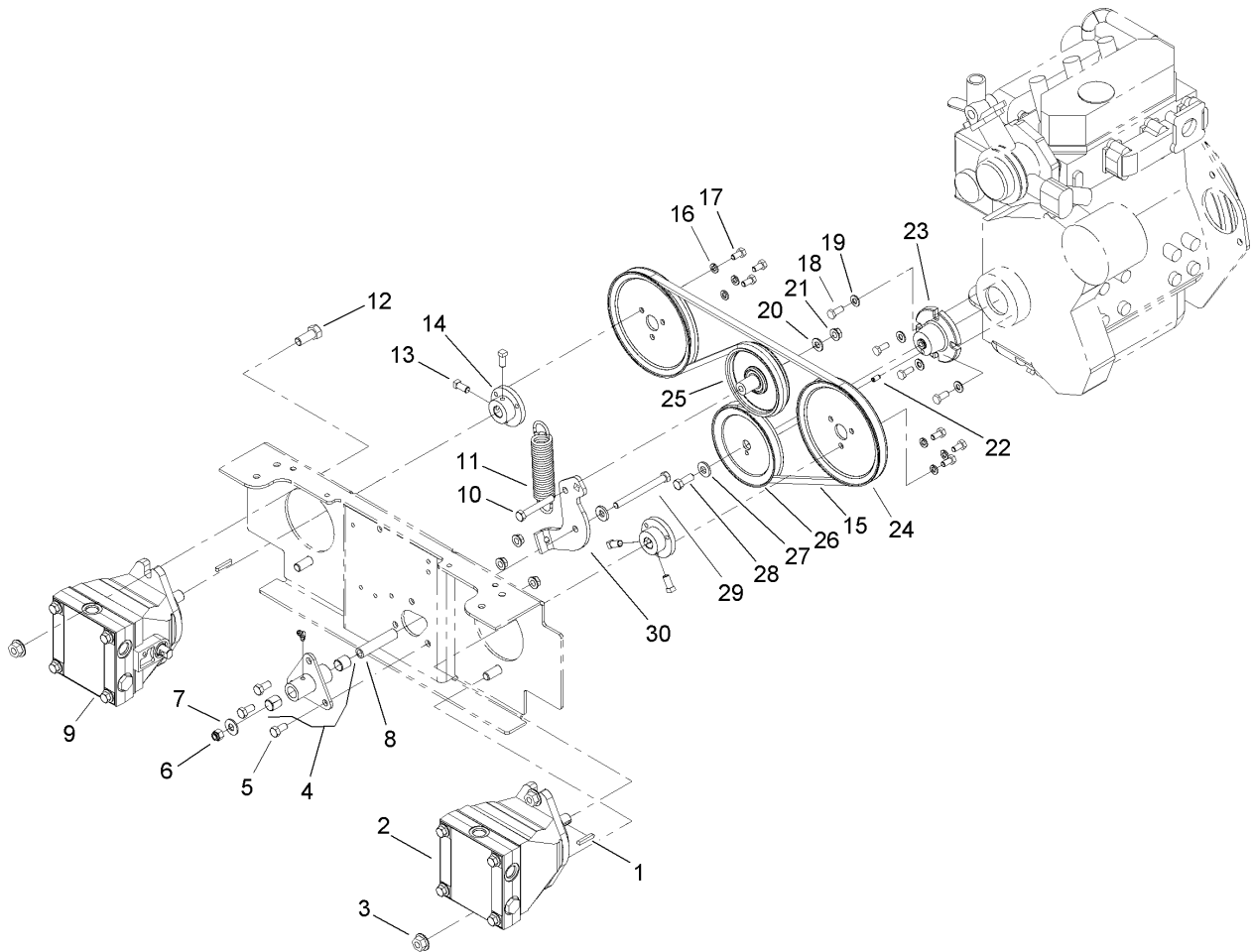

## Wheel Pump Drive Assembly

Ref	Part No.	Qty.	Description	Ref	Part No.	Qty.	Description
1	103-2739	2	Key	25	103-4464	1	Idler-Pump
2	103-2978	1	Pump-Hydro, LH	26	103-5164	1	Sheave-Engine
3	32128-49	4	Nut-HHF	27	98-5975	2	Washer-Belleville
4	103-4467	1	Pump Idler ASM	28	323-6	1	Screw-HH
5	323-4	3	Screw-HH	29	323-16	1	Screw-HH
6	3296-39	1	Nut-Lock, NI	30	103-4463-03	1	Arm-Tightener, Pump
7	3256-4	1	Washer-Flat				
8	103-0919	1	Bushing-Tightner, Pivot				
9	103-2979	1	Pump-Hydro, RH				
10	323-12	1	Screw-HH				
11	103-1767	1	Spring-Extension				
12	325-5	4	Screw-HH				
13	1-803050	4	Screw-Set				
14	103-1471	2	Hub-Pump				
15	107-7724	1	Belt-V				
16	1-805005	6	Washer-Lock				
17	322-2	6	Screw-HH				
18	33114-020	4	Screw-HH				
19	3256-23	4	Washer-Flat				
20	3256-24	1	Washer-Flat				
21	3290-357	4	Nut-HHF, Whiz				
22	103-1459	1	Pin-Roll				
23	103-1421	1	Hub-Drive, Pump				
24	103-1472	2	Sheave-Pump				

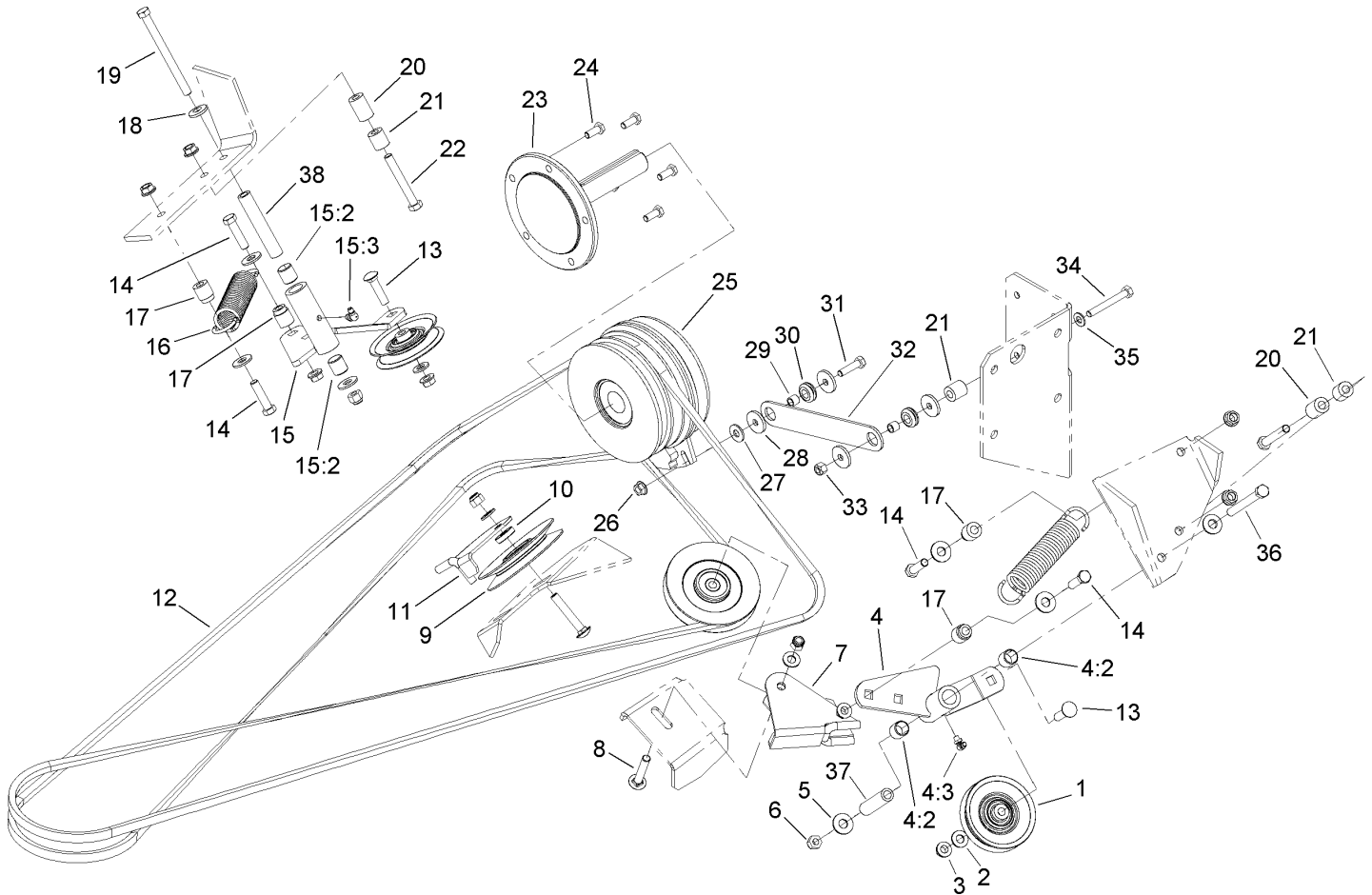

## Deck Belt Drive Assembly

Ref	Part No.	Qty.	Description
1	103-0983	2	Sheave
2	3256-24	4	Washer-Flat
3	3290-357	7	Nut-HHF, Whiz
4	107-9851	1	LH Idler ASM
4:2	1-513034	2	Sleeve-Bearing
4:3	302-40	1	Fitting-Grease
5	3256-4	6	Washer-Flat
6	3296-39	4	Nut-Lock, NI
7	103-4011-03	1	Guard-Belt Sheave, LH
8	3231-40	2	Bolt-CARR
9	103-0984	2	Sheave
10	103-3186	1	Spacer-Bracket, Guide
11	103-4039-03	1	Guard-Belt Sheave, RH
12	107-7738	2	Belt-V
13	3231-4	2	Screw-CARR
14	323-9	4	Screw-HH
15	107-9861	1	RH Idler ASM
15:2	1-513034	2	Sleeve-Bearing
15:3	302-40	1	Fitting-Grease
16	103-1767	2	Spring-Extension
17	103-1503	4	Spacer-Tightener, Belt
18	98-5975	2	Washer-Belleville
19	323-23	1	Screw-HH
20	103-1361	2	Spacer-Hydro Control, LH

Ref	Part No.	Qty.	Description
21	103-0193	3	Spacer-Strap, Clutch
22	323-13	2	Screw-HH
23	103-0286	1	Shaft-Stub
24	33114-020	5	Screw-HH
25	103-0083	1	Clutch ASM
26	32128-20	1	Nut-HF
27	3256-3	1	Washer-Flat
28	1-613235	4	Washer
29	1-633545	2	Spacer
30	1-633630	2	Grommet-Brake
31	322-6	1	Screw-HH
32	103-0192-03	1	Strap-Clutch / Brake
33	3296-29	1	Nut-Lock, NI
34	322-12	1	Screw-HH
35	3256-23	1	Washer-Flat
36	323-16	1	Screw-HH
37	103-0919	1	Bushing-Tightner, Pivot
38	103-0040	1	Bushing-Tightener, Pivot

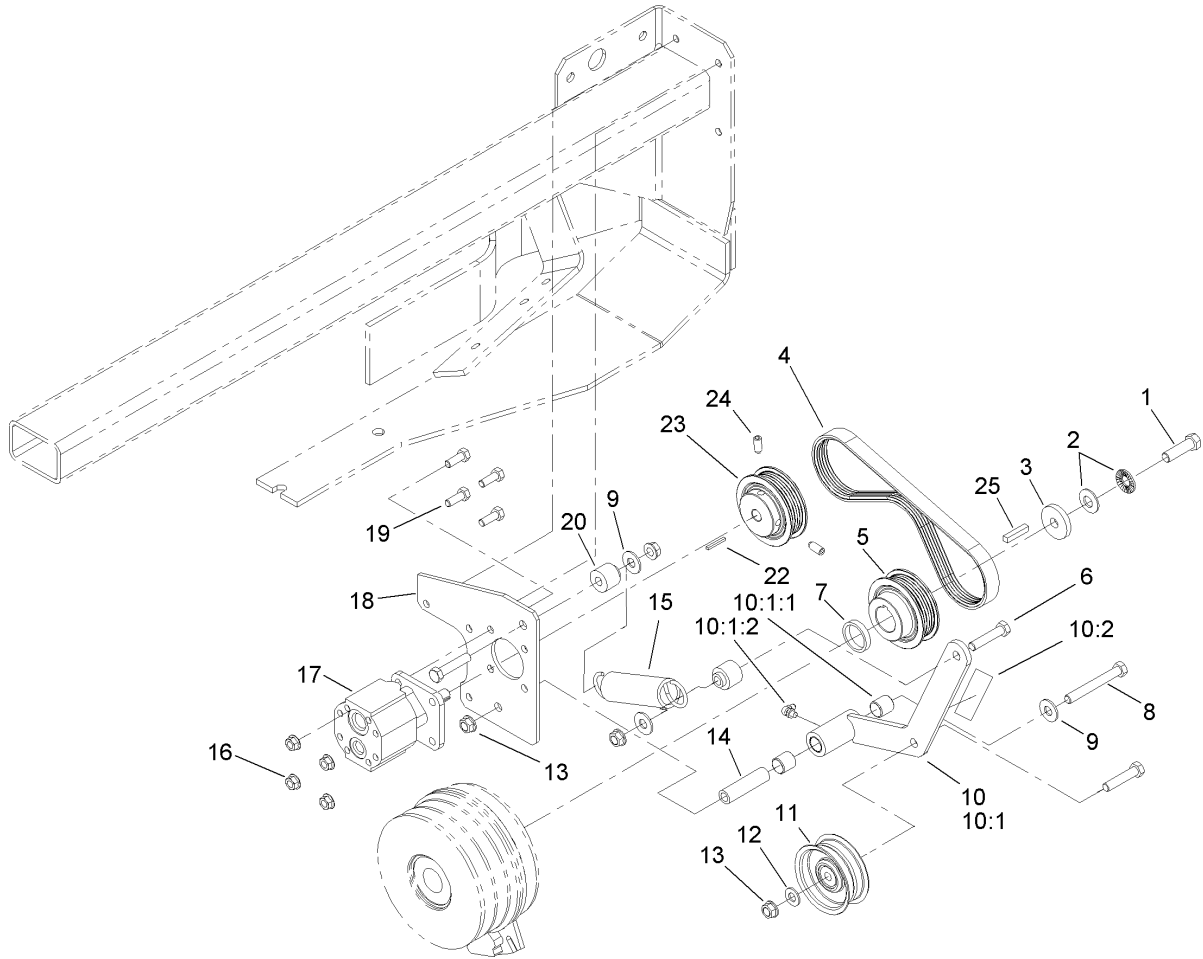

### Cooling Pump Drive Assembly

Ref	Part No.	Qty.	Description
1	3212-6	1	Screw-HH
2	1-603610	2	Washer-Spring
3	1-543610	1	Washer-Clutch
4	107-7739	1	Belt-Poly V
5	103-1339	1	Sheave-5 Rib
6	323-9	3	Screw-HH
7	103-1422	1	Spacer-Pump Drive, Fan
8	323-14	1	Screw-HH
9	3256-4	3	Washer-Flat
10	107-9879	1	Wheel Pump Tension ASM
10:1		1	Tensioner ASM
10:1:1	1-513034	2	Sleeve-Bearing
10:1:2	302-40	1	Fitting-Grease
10:2	98-5954	1	Decal-Missing, Cover
11	1-633167	1	Sheave-Idler
12	3256-24	1	Washer-Flat
13	3290-357	4	Nut-HHF, Whiz
14	1-603384	1	Bushing-Pivot, Idler
15	1-603414	1	Spring-Extension
16	32128-20	4	Nut-HF
17	103-7431	1	Pump-Fan, Cooling
18	103-1299-03	1	Plate-Mating, Fan Pump
19	322-4	4	Screw-HH
20	103-1575	2	Spacer-Spring, Fan Pump

Ref	Part No.	Qty.	Description
22	32150-1	1	Key-Square
23	103-1338	1	Sheave-5 Rib
24	3246-6	2	Screw-Set, HSH
25	13-2840	1	Key-Square

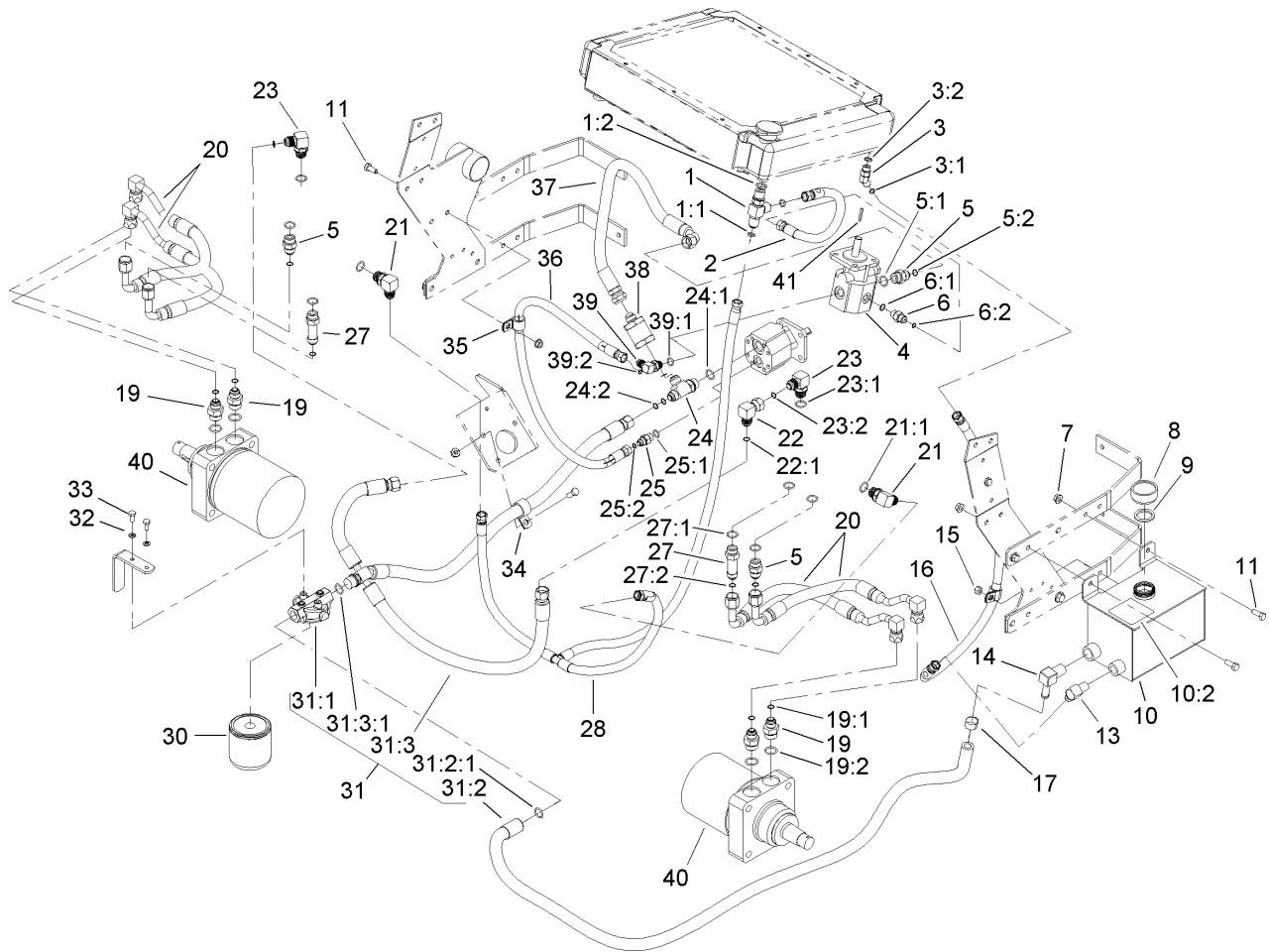

## Hydraulic System Assembly

Ref	Part No.	Qty.	Description
1	108-5998	1	Fitting-HYD, Straight Tee
1:1	237-21	2	O-Ring
1:2	237-42	1	O-Ring
2	103-2173	1	Fan Case Drain Hose ASM
3	108-5999	1	Fitting-HYD, 45 Elbow
3:1	237-21	1	O-Ring
3:2	237-42	1	O-Ring
4	103-7430	1	Motor-Fan, Cooling
5	1-603990	3	Fitting-Straight
5:1	1-603920	1	O-Ring
5:2	1-603992	1	O-Ring
6	103-2157	1	Fitting-Straight
6:1	1-603923	1	O-Ring
6:2	103-1020	1	O-Ring
7	32128-20	6	Nut-HF
8	1-513167	1	Cap
9	1-523103	1	Gasket-Cap, Tank
10	107-7659	1	HYD Tank ASM
10:2	1-523552	1	Decal-Tank, HYD
11	322-4	6	Screw-HH
13	103-1012	1	Fitting-Elbow, 90 DEG
14	103-2152	1	Fitting-90 DEG
15	3296-29	1	Nut-Lock, NI
16	103-2174	1	Tank Return Hose ASM

Ref	Part No.	Qty.	Description
17	103-2104	1	Clamp-Hose
19	1-603991	4	Fitting-Straight
19:1	237-80	1	O-Ring
19:2	1-603992	1	O-Ring
20	103-4679	4	Hose
21	103-1014	2	Fitting-Elbow, 90 DEG
21:1	1-603920	1	O-Ring
22	103-2315	1	Fitting-90 DEG
22:1	1-603992	1	O-Ring
23	103-2153	2	Fitting-90 DEG
23:1	1-603920	1	O-Ring
23:2	1-603992	1	O-Ring
24	103-2159	1	Fitting-Tee
24:1	1-603920	1	O-Ring
24:2	1-603992	2	O-Ring
25	103-2156	1	Fitting-Straight
25:1	1-603921	1	O-Ring
25:2	103-1020	1	O-Ring
27	103-1940	2	Adapter-HYD, Straight
27:1	237-79	1	O-Ring
27:2	1-603992	1	O-Ring
28	103-2172	1	Case Drain Hose ASM
30	23-9740	1	Filter-Oil
31	103-5120	1	Charge Hose ASM

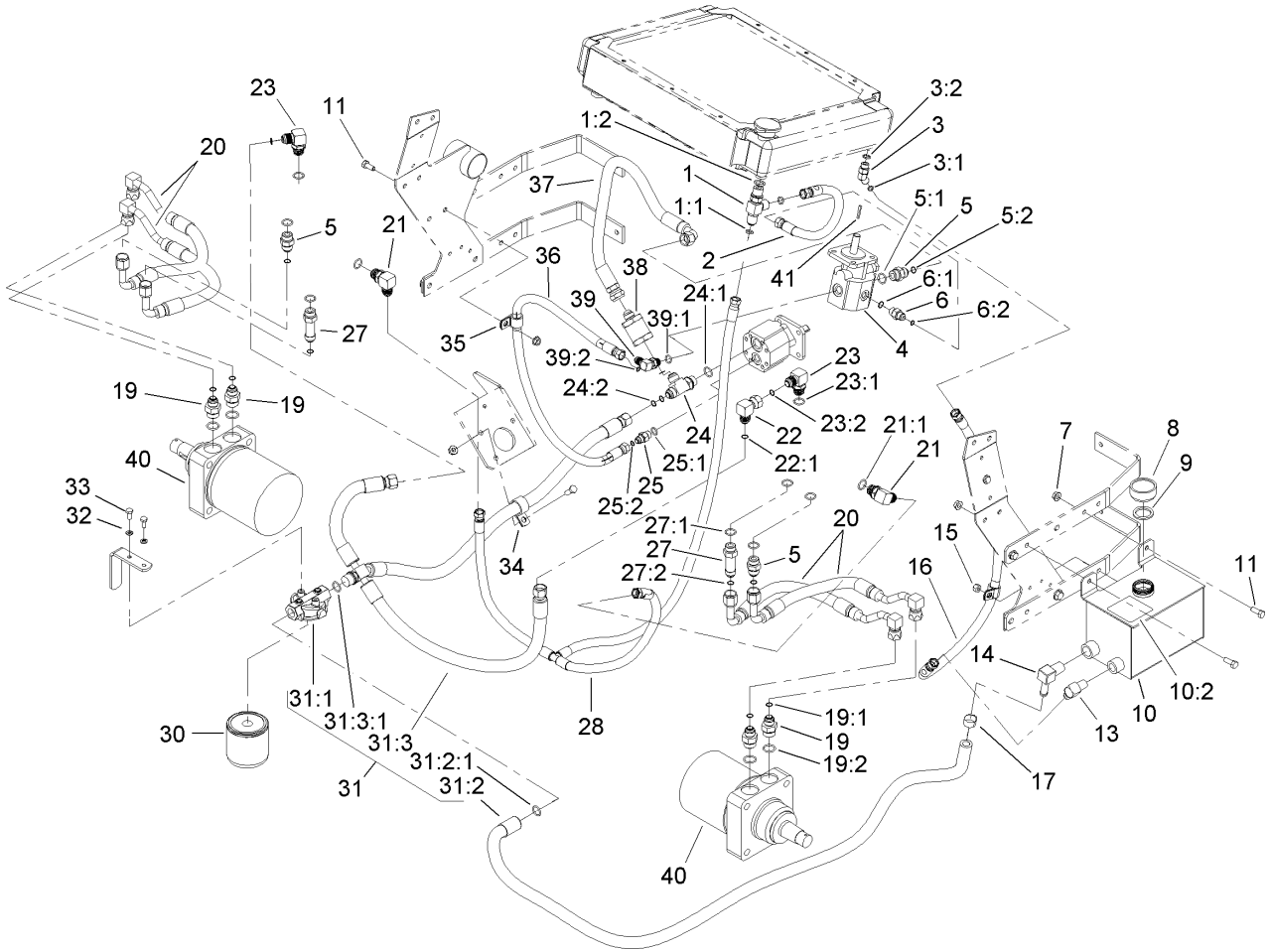

## Hydraulic System Assembly (continued)

Ref	Part No.	Qty.	Description
31:1	103-2259	1	Head-Filter
31:2	103-5121	1	Filter Inlet Hose ASM
31:2:1	1-603920	1	O-Ring
31:3	103-2269	1	Pump Inlet Hose ASM
31:3:1	1-603920	1	O-Ring
32	1-805004	2	Washer-Lock
33	321-3	2	Screw-HH
34	1-643312	1	Clip-Loom
35	1-633396	2	Clip-Loom
36	103-2148	1	Auxillary Pump Hose ASM
37	1-323241	1	Hose-Pressure, High
38	103-3110	1	Filter-In Line, 50 Micron
39	103-2155	1	Fitting-90 DEG
39:1	1-603921	1	O-Ring
39:2	103-1020	1	O-Ring
40	103-2489	2	Motor-Wheel, HYD
41	32150-1	1	Key-Square

--	--	--	--

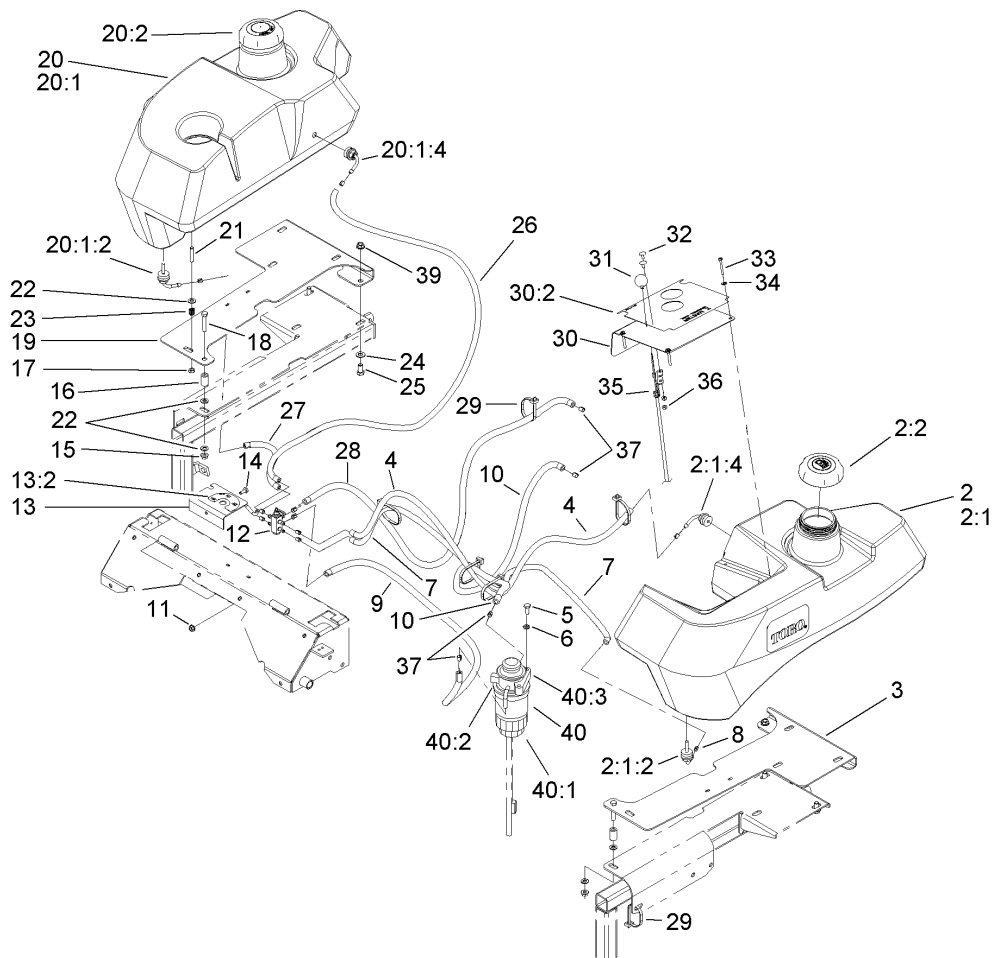

## Tank and Fuel Line Assembly

Ref	Part No.	Qty.	Description
2	110-4167	1	LH Tank Kit ASM
②2:1		1	LH Fuel Tank ASM
2:1:2	103-2605	1	Fitting-Fuel, Bulkhead
2:1:4	103-2615	1	Fitting-Fuel, Bulkhead
2:2	109-0347	1	Cap-Fuel, Diesel
3	107-7672-03	1	Bracket-Fuel Tank, LH
4	107-7686	1	Hose-Fuel
5	33114-020	2	Screw-HH
6	1-805005	2	Washer-Lock
7	107-7742	1	Hose-Fuel
8	1-643293	8	Clamp-Hose, Fuel
9	107-7687	1	Hose-Fuel
10	103-1693	1	Hose-Fuel
11	32128-23	1	Nut-HF
12	1-643234	1	Valve-Fuel, Dual Flow
13	107-9878	1	Bracket-Valve, Fuel
13:2	107-2114	1	Decal-Valve, Fuel
14	321-3	1	Screw-HH
15	3296-47	2	Nut-Lock, NI
16	94-7564	2	Spacer
17	3296-47	6	Nut-Lock, NI
18	322-9	2	Screw-HH
19	107-7671-03	1	Bracket-Fuel Tank, RH
20	110-4166	1	RH Tank Kit ASM

Ref	Part No.	Qty.	Description
②20:1		1	RH Fuel Tank ASM
20:1:2	103-2605	1	Fitting-Fuel, Bulkhead
20:1:4	103-2615	1	Fitting-Fuel, Bulkhead
20:2	109-0347	1	Cap-Fuel, Diesel
21	1-633023	6	Stud
22	3256-23	10	Washer-Flat
23	1-633349	6	Spring-Tank, Fuel
24	3256-24	4	Washer-Flat
25	323-4	4	Screw-HH
26	99-3185	1	Hose-Fuel
27	107-7684	1	Hose-Fuel
28	107-7741	1	Hose-Fuel
29	1-303335	6	Tie-Plastic
30	107-7703	1	Panel-Control
30:2	107-7701	1	Decal-Panel, Control
31	1-513592	1	Knob-Ball
32	1-807513	2	Bolt-CARR
33	1-803071	4	Screw
34	1-303435	4	Washer-Spring
35	103-1450	1	Cable-Throttle
36	3296-2	2	Nut-Lock
37	1-643277	6	Clamp-Hose, Fuel
39	3290-357	4	Nut-HHF, Whiz
40	100-3191	1	Separator-Fuel

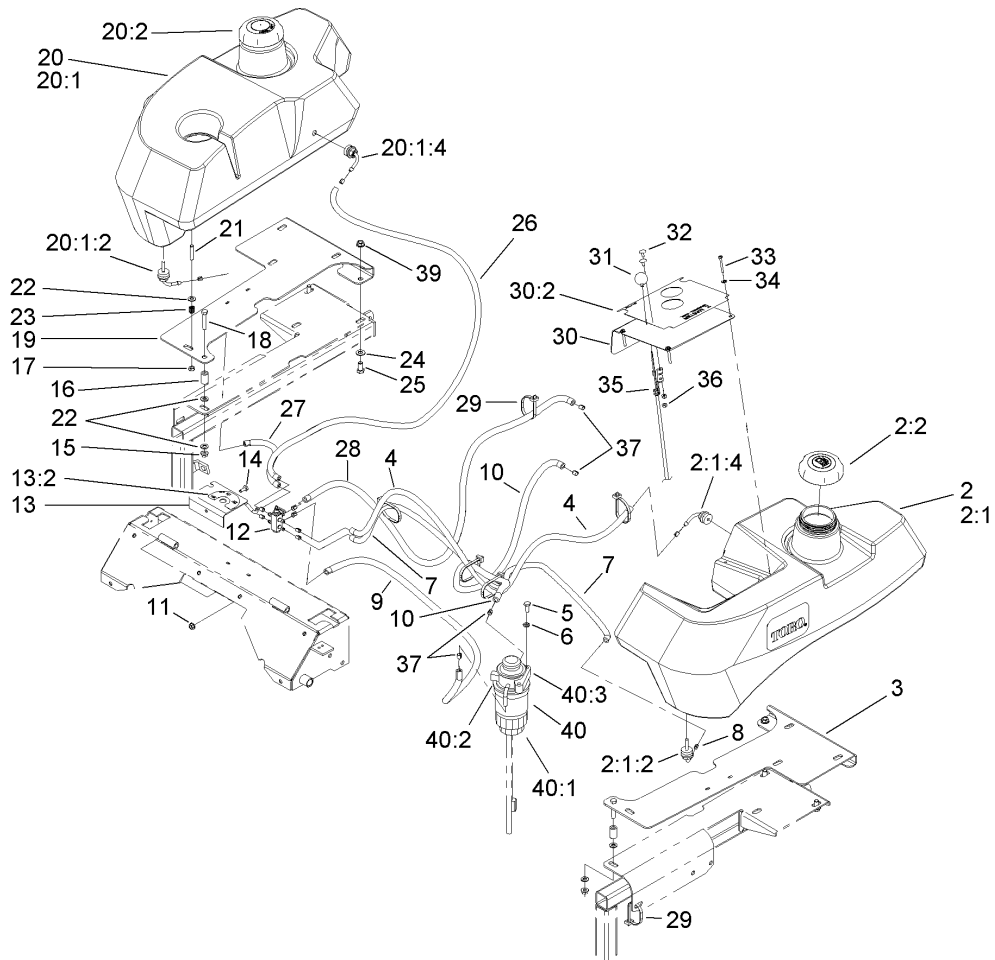

### Tank and Fuel Line Assembly (continued)

Ref	Part No.	Qty.	Description
40:1	100-3192	1	Element-Filter, Fuel
40:2	100-6409	1	Sensor-Filter, Fuel
40:3	100-6408	1	Cover-Filter

--	--	--	--

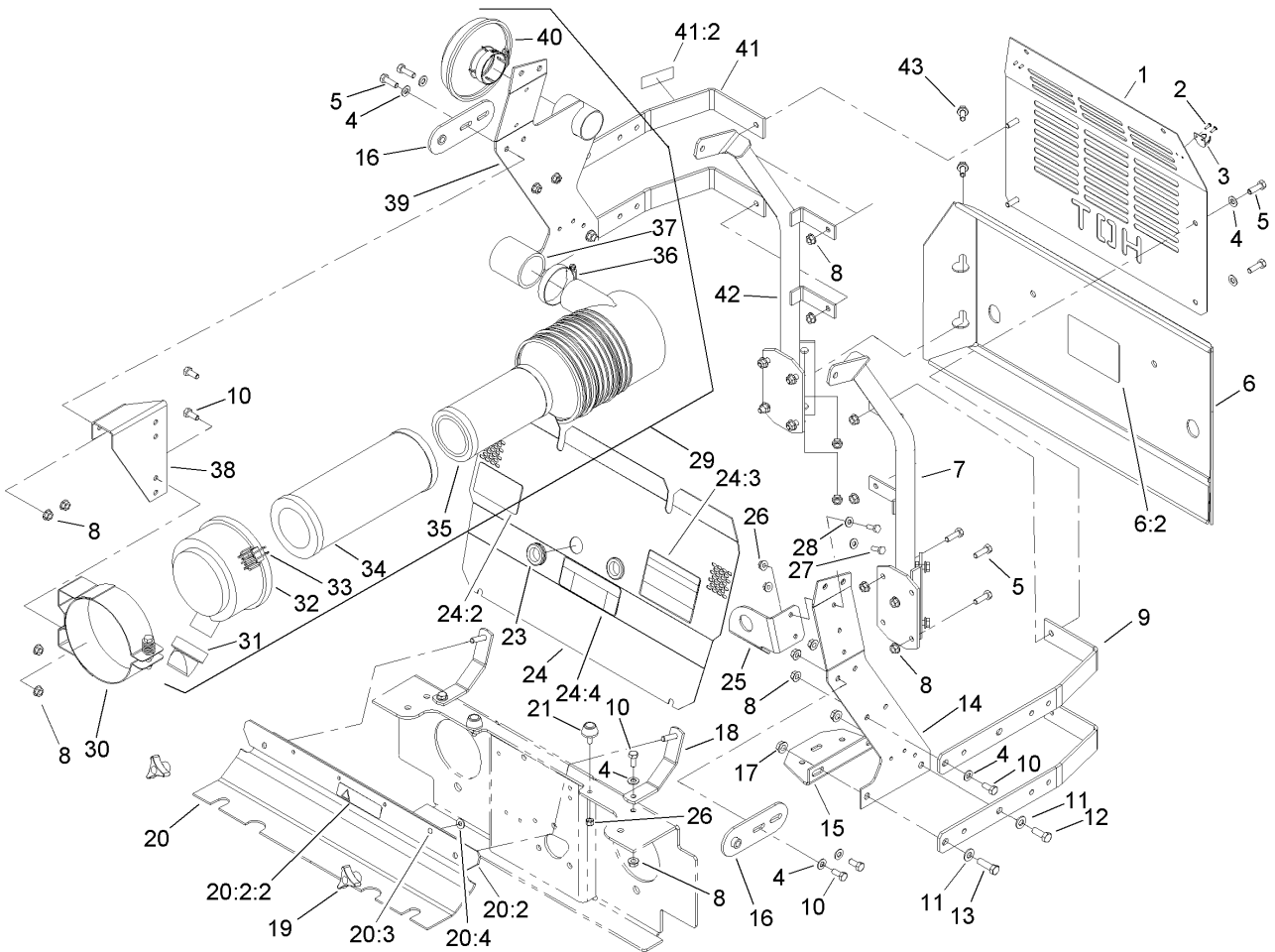

## Front and Rear Engine Cover Assembly

Ref	Part No.	Qty.	Description
1	103-4855-03	1	Guard-Muffler
2	923786	4	Rivet
3	1-643189	2	Keeper-Latch, Rubber
4	3256-23	13	Washer-Flat
5	322-5	14	Screw-HH
6	107-9865	1	Rear Bumper ASM
6:2	107-9864	1	Decal-Belt Routing, Deck Drive
7	103-5157-03	1	Frame-Upper, LH Rear
8	32128-20	23	Nut-HF
9	103-4906-03	3	Bar-Mount Frame, Radiator
10	322-3	9	Screw-HH
11	3256-24	4	Washer-Flat
12	323-6	2	Screw-HH
13	323-7	2	Screw-HH
14	103-5169-03	1	Mount-Side, LH
15	103-2603-03	1	Bracket-Bottle
16	1-632986-03	2	Shackle-Hinge
17	3290-357	4	Nut-HHF, Whiz
18	103-5163-03	2	Mount-Belt Shield, Engine
19	1-323385	2	Knob-3 Prong
20	107-7709	1	Engine Belt Shield ASM
20:2	107-7713	1	Strip-Shield, Belt
20:2:2	98-5954	1	Decal-Missing, Cover
20:3	1-803035	4	Rivet-Pop

Ref	Part No.	Qty.	Description
20:4	3256-14	4	Washer-Flat
21	1-523420	2	Bumper
23	100-3815	2	Grommet-Rubber
24	107-7707	1	Engine Access Panel ASM
24:2	107-7705	1	Decal-Belt Routing, Pump
24:3	103-3276	1	Decal-Buzzer, Warning
24:4	103-5881	1	Decal-Devices, Rotating
25	103-4982-03	1	Bracket-Buzzer
26	32128-33	2	Nut-HF
27	321-4	2	Screw-HH
28	3256-22	2	Washer-Flat
29	103-5178	1	Filter-Air
30	103-1058	1	Bracket-Filter, Air
31	87-9400	1	Valve-Vacuator
32	103-1060	1	Cover-Filter, Air
33	1-643283	2	Latch-Cleaner, Air
34	103-1327	1	Filter-Air
35	103-1326	1	Filter-Air, Safety
36	2412-42	1	Clamp-Hose
37	103-5198	1	Hose-Intake
38	103-0953-03	1	Mount-Cleaner, Air
39	103-5123-03	1	RH Radiator And Ac Support ASM
40	100-2436	1	Hood
41	107-7715	1	Bar-Radiator



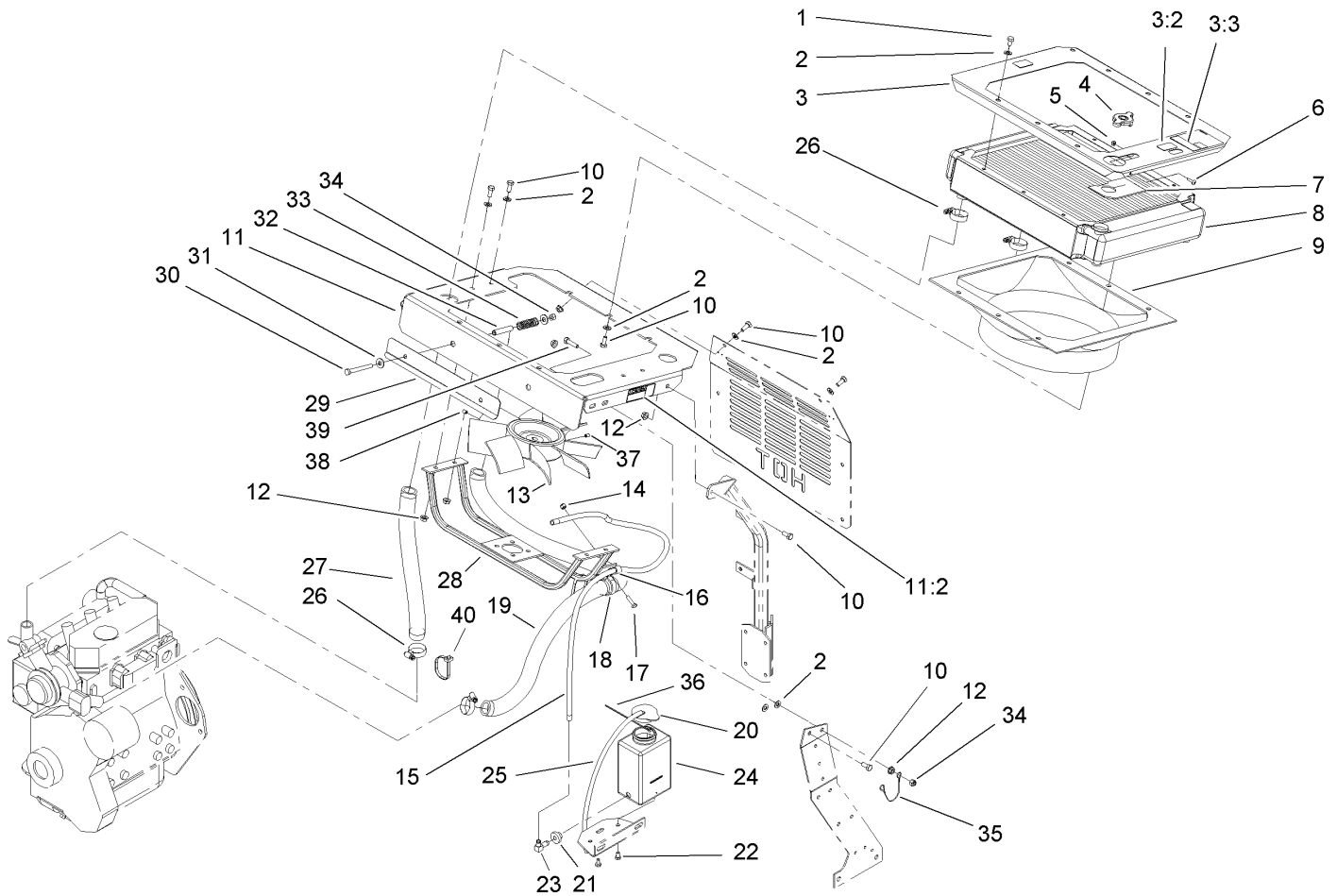

## Cooling System Assembly

Ref	Part No.	Qty.	Description
1	322-1	6	Screw-HH
2	3256-23	22	Washer-Flat
3	107-7658	1	Plate-Trim, Radiator
3:2	65-2690	2	Decal-Surface, Hot
3:3	104-2449	1	Decal-Coolant
4	1-643161	1	Cap-Radiator
5	3296-2	1	Nut-Lock
6	1-803075	1	Screw-Head, Truss
7	103-1352	1	Shield-Fill Neck, Radiator
8	107-9889	1	Radiator
9	103-0898	1	Shroud-Cooling, Engine
10	322-3	16	Screw-HH
11	107-7717	1	Fan Mounting Plate ASM
11:2	1-643253	2	Decal-Fan, Radiator
12	32128-20	10	Nut-HF
13	103-0892	1	Fan
14	3296-42	1	Nut-Lock, NI
15	103-1445	1	Hose
16	1-513762	1	Clip-Loom
17	321-6	1	Screw-HH
18	103-0113	1	Clip-Loom
19	103-0922	1	Hose-Inlet, Engine
20	1-643164	1	Cap-Tank, Overflow
21	1-513645	1	Bushing-Valve, Fuel

Ref	Part No.	Qty.	Description
22	321-2	2	Screw-HH
23	1-643259	1	Fitting-Elbow
24	1-643163	1	Tank-Overflow
25	1-643131	1	Hose
26	1-633989	4	Clamp-Hose
27	103-2505	1	Hose-Outlet, Engine
28	103-0086-03	1	Mount-Motor, Fan
29	103-4986	1	Bracket-Deflector, Air
30	322-14	2	Screw-HH
31	3256-3	4	Washer-Flat
32	103-5223	2	Spacer
33	1-513296	2	Spring-Indicator, Reverse
34	3296-29	4	Nut-Lock, NI
35	107-9853	2	Lanyard
36	1-303287	3	Tie-Plastic
37	3245-44	1	Screw-Set
38	909848	1	Screw-Set
39	322-6	2	Screw-HH
40	1-303335	2	Tie-Plastic





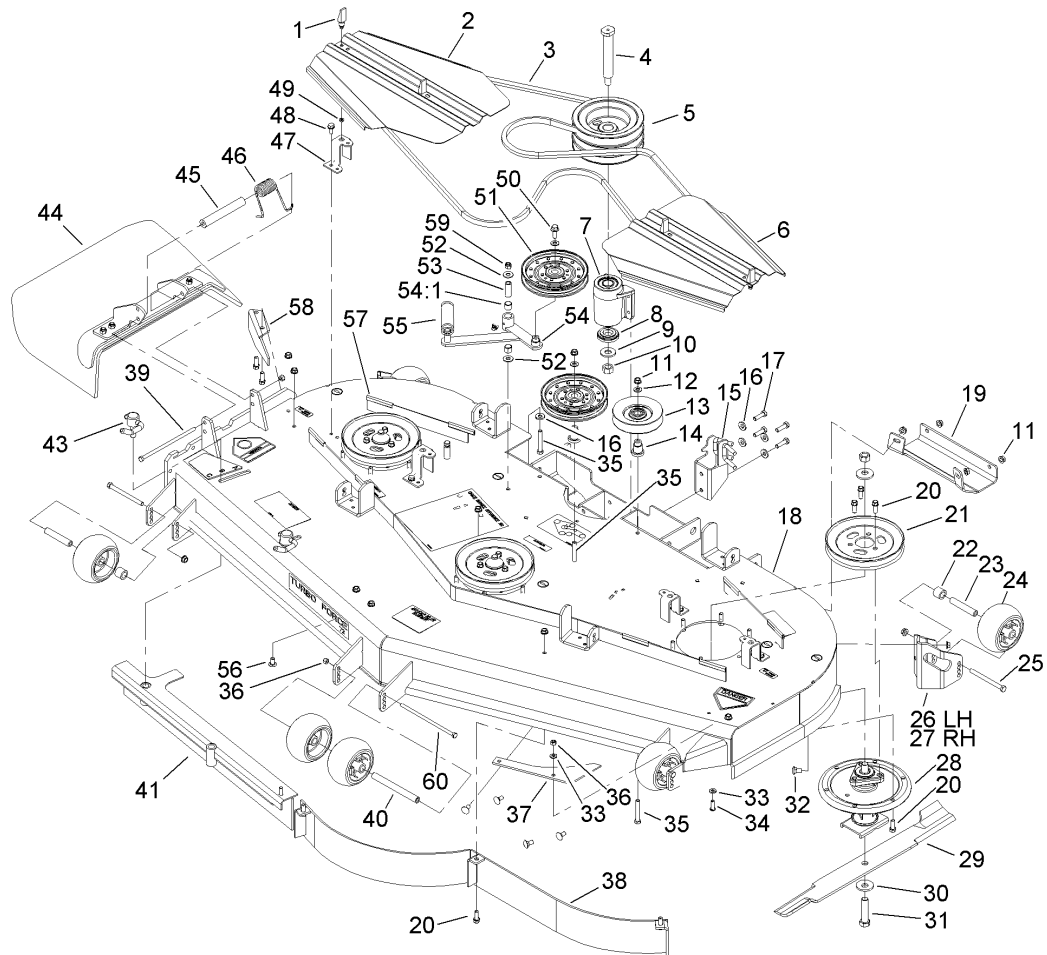

## Deck Assembly

Ref	Part No.	Qty.	Description
1	74-5950	4	Latch-Swell
2	106-3275-03	1	Cover-Belt
3	107-7723	1	Belt-V
4	1-643393	1	Jackshaft
5	103-5381	1	Sheave-Jackshaft
6	105-8786-03	1	Cover-Belt
7	103-2544	1	Jackshaft ASM
8	103-2535	1	Spacer-Guard, Bottom
9	1-513208	1	Washer-Spring
10	3219-6	1	Nut-Hex
11	3290-357	36	Nut-HHF, Whiz
12	3256-24	3	Washer-Flat
13	1-603805	1	Pulley-Idler
14	106-3214	2	Mount-Pulley
15	103-3445-01	1	Guard-Jackshaft
16	98-5975	5	Washer-Belleville
17	323-7	4	Screw-HH
18	107-7677	1	Deck Decal ASM
19	106-3279-01	1	Plate-Skid
20	92-1624	33	Screw
21	107-7678	3	Pulley
22	98-7913	4	Tube-Spacer
23	98-7912	4	Tube-Spanner
24	1-603299	6	Roller-Scalp, Anti

Ref	Part No.	Qty.	Description
25	323-23	4	Screw-HH
26	106-7354-01	1	Plate-Roller, LH
27	106-7355-01	1	Plate-Roller, RH
28	106-3217	3	Spindle ASM
29	105-7784-03	3	Blade-Hi Flow, 24.5 Inch
30	103-0865	3	Washer-Blade Bolt, Heavy
31	103-0862	3	Screw-Cap
32	3231-1	10	Screw-CARR
33	1-303334	4	Washer-Spring
34	3274-104	2	Screw-HSBH
35	323-12	3	Screw-HH
36	3296-29	4	Nut-Lock, NI
37	107-3138	1	Plate-Turbo
38	105-7730-01	1	Baffle ASM
39	322-50	1	Screw-HH
40	98-5967	1	Spacer-Wheel
41	105-7669-01	1	Baffle ASM
43	107-1664	2	Lever ASM
44	108-2792	1	Rubber Deflector ASM
45	105-4622	1	Spacer
46	108-4052	1	Spring-Torsion
47	108-4121-01	4	Bracket-Cover
48	32144-70	4	Screw-HH
49	99-3058	4	Washer



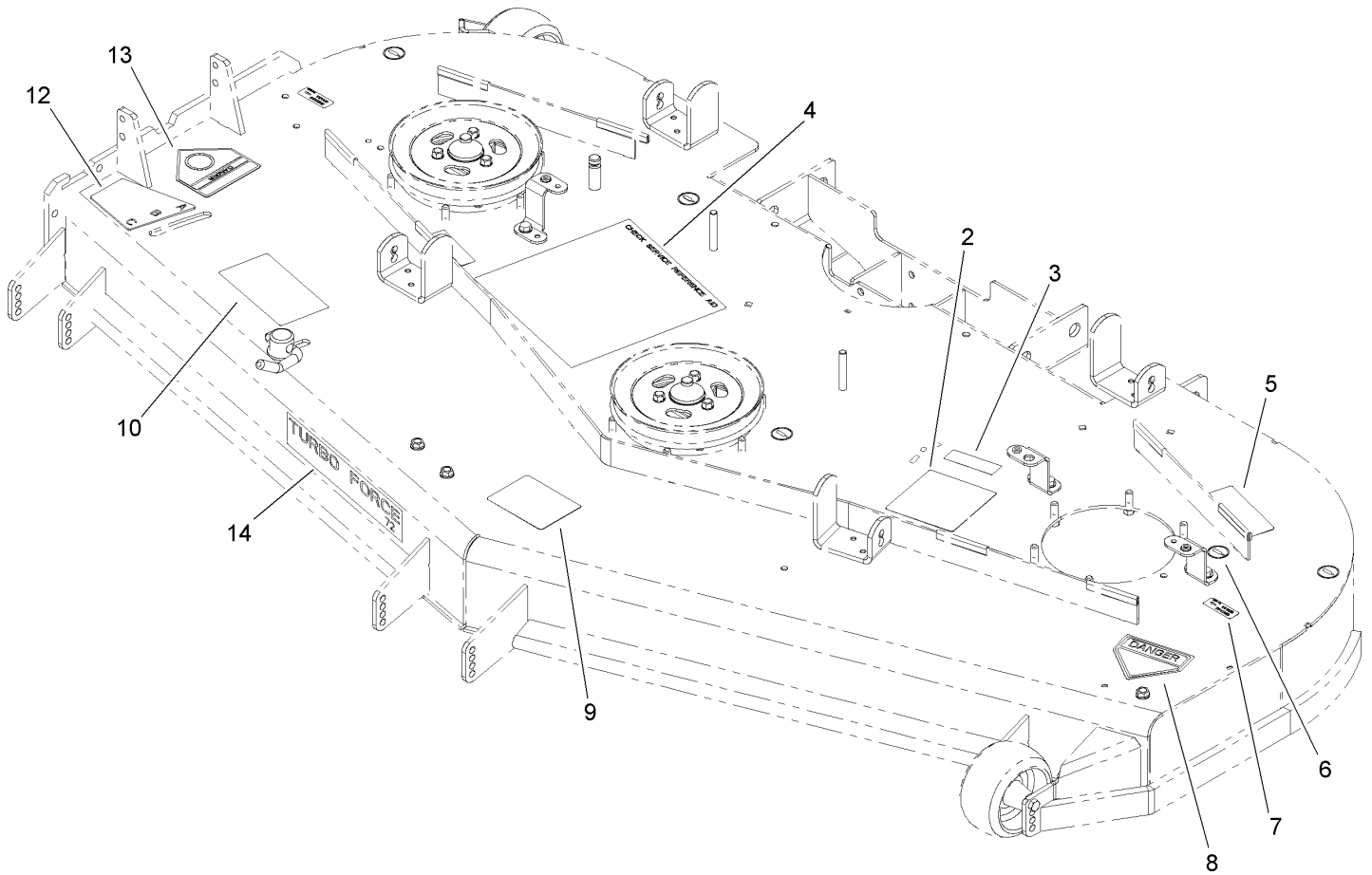

## Deck Decal Assembly No. 107-7677

Ref	Part No.	Qty.	Description
2	107-7673	1	Decal-Routing, Belt
3	98-5954	3	Decal-Missing, Cover
4	107-9863	1	Decal-Check, Service
5	68-8340	1	Decal-Torque
6	58-6520	6	Decal-Grease
7	107-1613	2	Decal-Grease
8	1-403005	1	Decal-Danger
9	105-7798	1	Decal-Scalp, Anti
10	66-1340	1	Decal-Danger
12	107-1622	1	Decal-Adjustment, Baffle
13	54-9220	1	Decal-Danger
14	107-1620	1	Decal

--	--	--	--

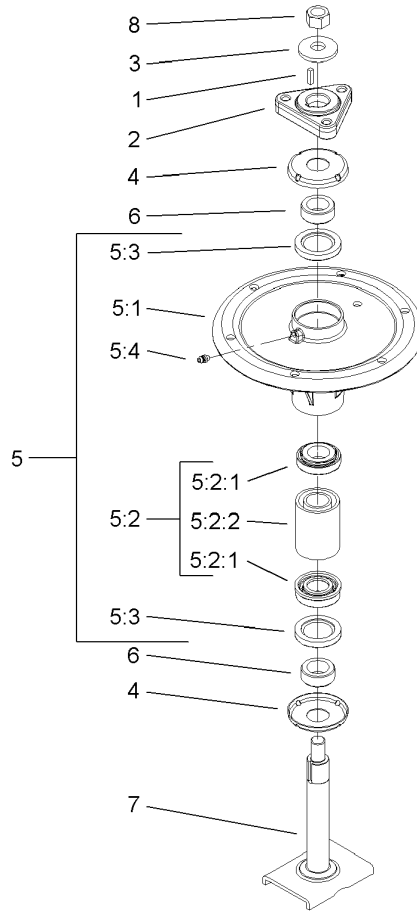

## Spindle Assembly No. 106-3217

Ref	Part No.	Qty.	Description
1	10-8040	1	Key-Square
2	106-3277	1	Hub-Pulley
3	103-0865	1	Washer-Blade Bolt, Heavy
4	106-3204	2	Shield-Bearing
5		1	Spindle Bearing ASM
5:1	106-3211	1	Housing-Spindle
5:2	106-3207	1	Bearing ASM
5:2:1	27-0960	1	Bearing ASM
5:2:2	106-3206	1	Spacer-Set, Matched
5:3	253-133	2	Seal-Oil
5:4	302-5	1	Fitting-Grease
6	106-3218	2	Spacer-Seal
7	106-3233	1	Spindle Shaft ASM
8	3219-6	1	Nut-Hex

--	--	--	--





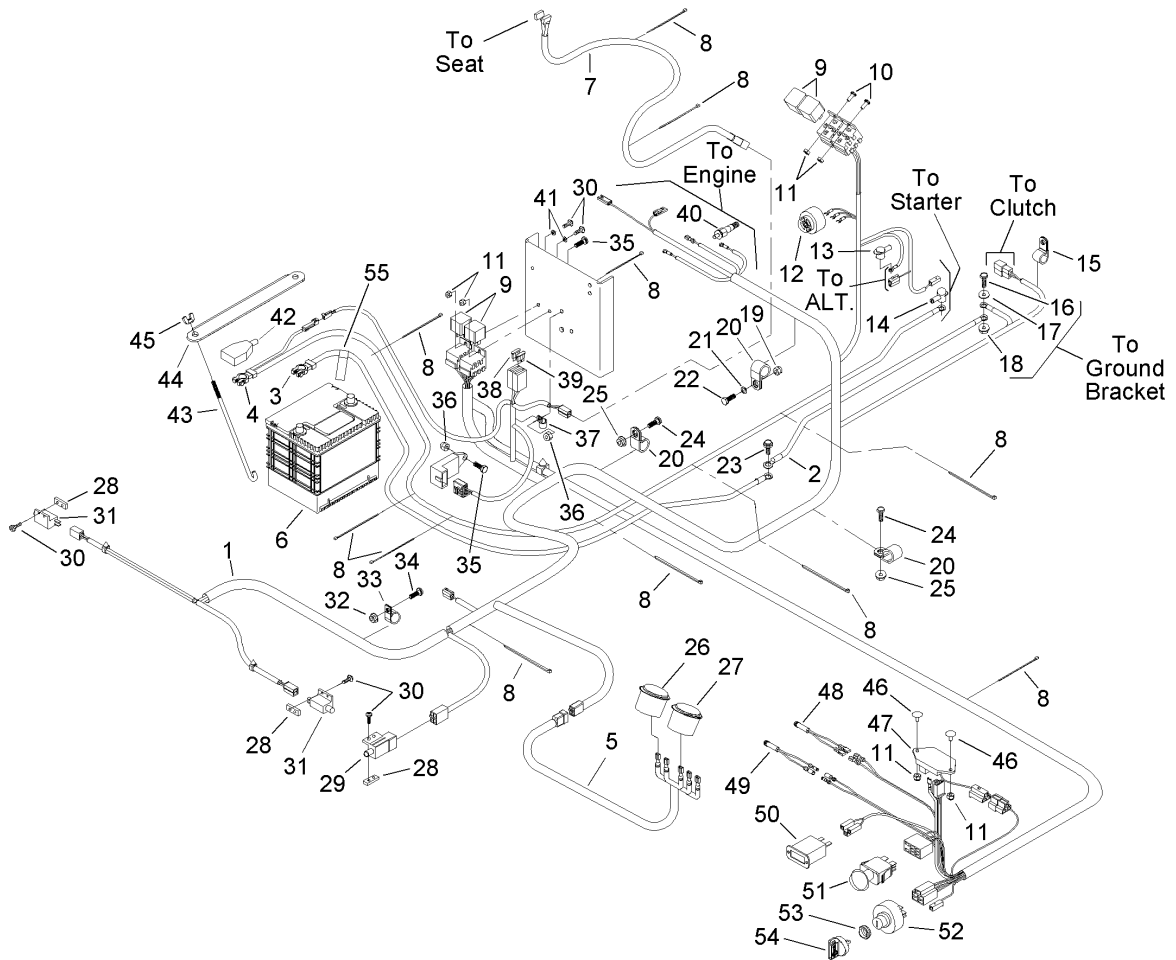

## Electrical Component Assembly

Ref	Part No.	Qty.	Description
1	103-4340	1	Harness-Wire
2	103-1349	1	Cable-Ground, Engine
3	103-1159	1	Cable-Ground, Battery
4	103-1160	1	Cable-Starter
5	103-4339	1	Harness-Gauge
6	106-5187	1	Battery
7	103-1227	1	Harness-Wiring, Seat
8	1-303335	11	Tie-Plastic
9	1-643275	4	Relay
10	1-803071	2	Screw
11	3296-2	8	Nut-Lock
12	103-0205	1	Alarm-Tone, Dual
13	1-643178	1	Cap-Insulator, Red
14	103-1420	1	Insulator-Starter
15	1-603727	1	Clip-Loom
16	323-6	1	Screw-HH
17	3256-24	1	Washer-Flat
18	3290-357	1	Nut-HHF, Whiz
19	33023-00	1	Nut-Lock
20	1-633396	3	Clip-Loom
21	3256-22	1	Washer-Flat
22	33113-020	1	Screw-HH
23	32144-70	1	Screw-HH
24	322-3	2	Screw-HH

Ref	Part No.	Qty.	Description
25	32128-20	2	Nut-HF
26	1-643037	1	Gauge-Voltmeter
27	1-643021	1	Gauge-Temperature
28	1-633181	3	Plate-Tapped
29	1-633111	1	Switch
30	3290-500	8	Screw-PPH
31	1-513051	2	Switch-Open, Normally
32	32128-33	1	Nut-HF
33	1-323229	1	Clip-Loom
34	321-2	1	Screw-HH
35	321-4	3	Screw-HH
36	3296-42	2	Nut-Lock, NI
37	1-513762	1	Clip-Loom
38	1-816001	1	Fuse-Blade Type, 20 Amp
39	103-1368	1	Fuse-40 Amp
40	103-0949	1	Sender-Temperature
41	3256-14	2	Washer-Flat
42	103-1340	1	Insulator-Terminal, Battery
43	103-1312	2	Bolt-Holddown
44	103-1311-03	1	Holddown-Battery
45	1-543792	2	Wingnut
46	1-807513	2	Bolt-CARR
47	103-5218	1	Module-Delay, Seat
48	1-643267	1	Indicator-Led, Red

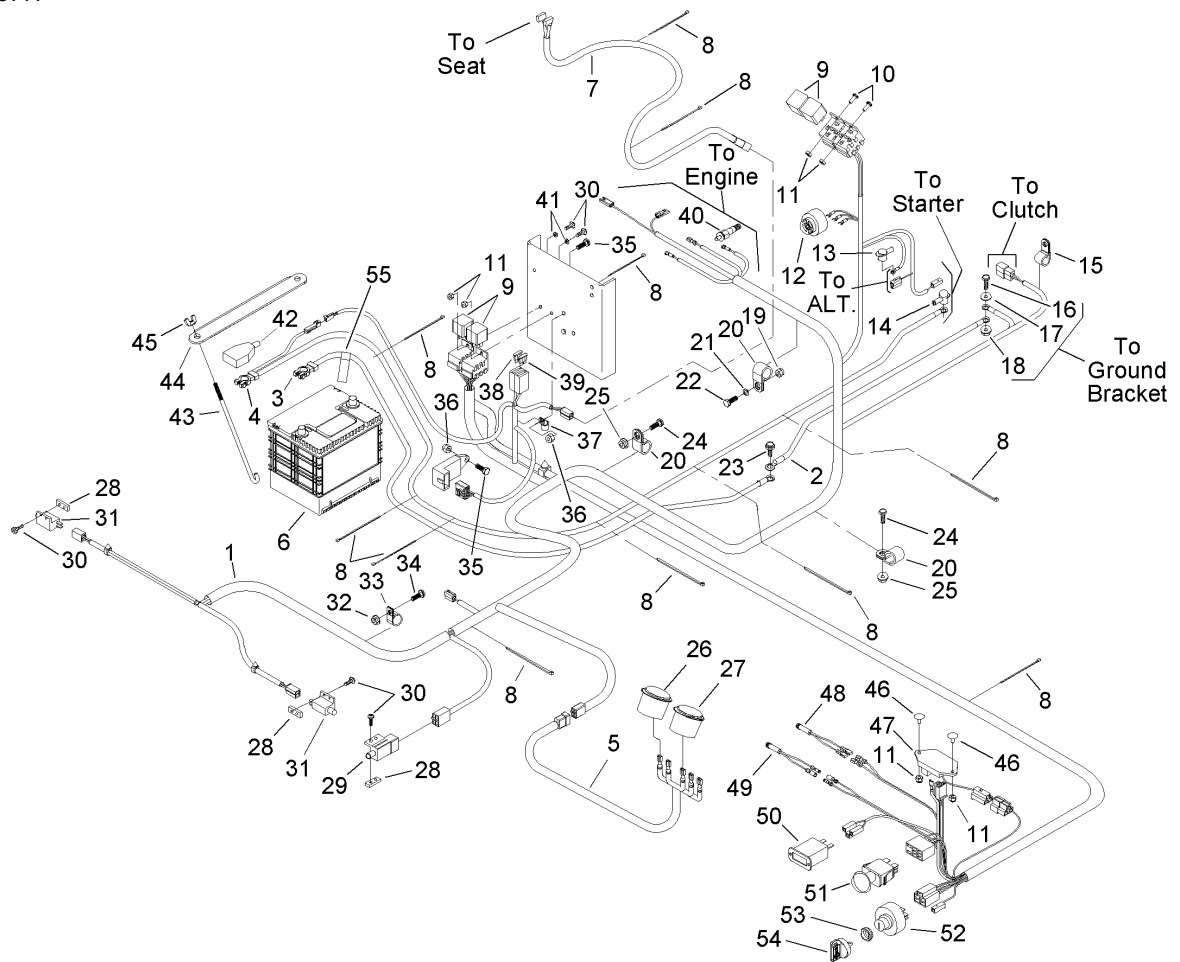

## Electrical Component Assembly (continued)

Ref	Part No.	Qty.	Description
49	103-1320	1	Indicator-Led, Amber
50	1-513374	1	Meter-Hour
51	103-5221	1	Switch-PTO
52	103-0206	1	Switch-Starting, Key
53	103-0498	1	Nut-Switch, Ignition
54	63-8360	2	Key-Ignition
55	107-9309	1	Decal-Instructions, Charging

--	--	--	--

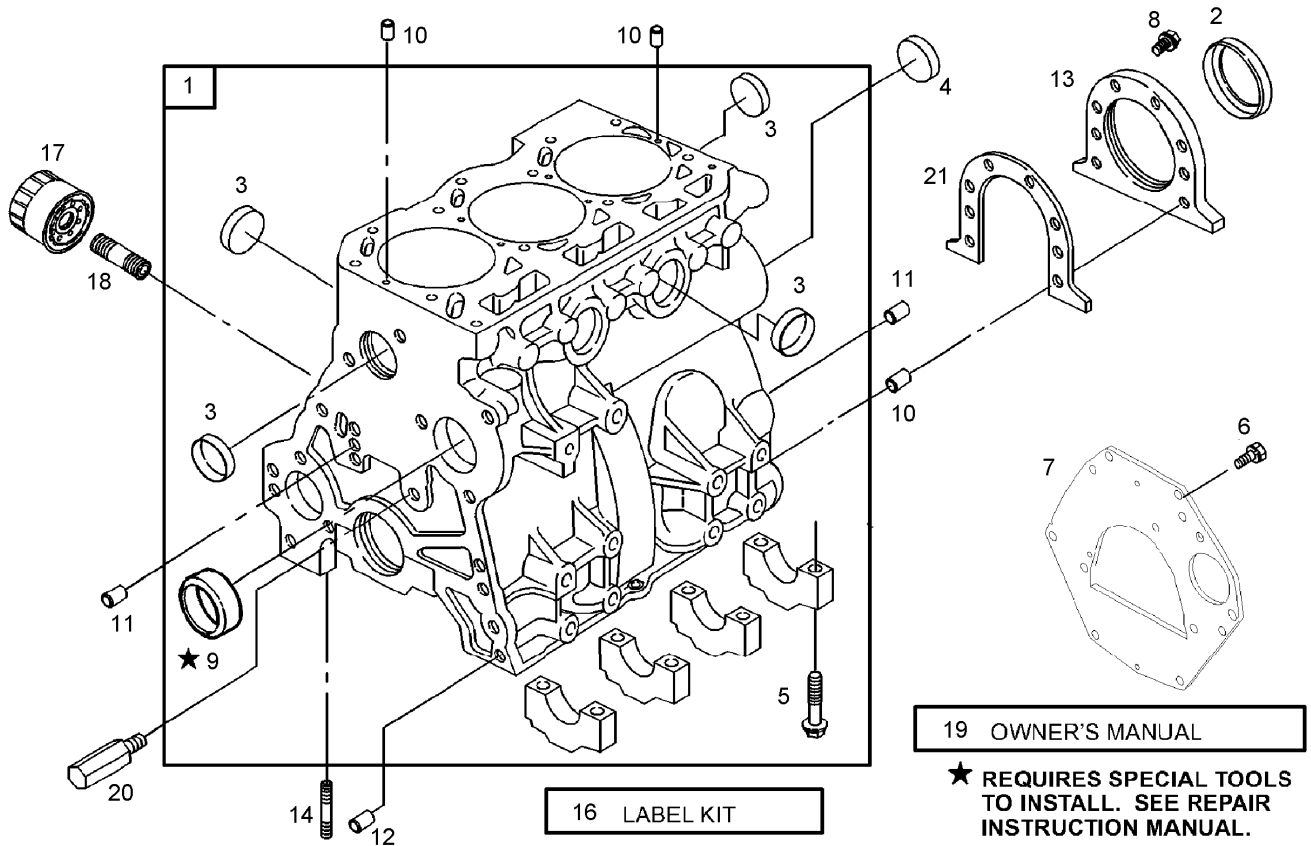

Assemblies include all parts shown in frames.

## Cylinder Assembly

Ref	Part No.	Qty.	Description
1	107-9891	1	Cylinder ASM
2	99-9003	1	Seal-Oil
3	99-9008	1	Plug-Welch
4	107-9892	1	Plug-Welch (Cam)
5	99-9006	1	Screw-Hex
6	99-9005	1	Screw-Hex
7	107-9893	1	Plate-End, Rear
8	99-9004	1	Screw-Hex
9	99-9002	1	Bushing
10	99-9012	1	Pin-Locating
11	99-9013	1	Pin-Locating
12	99-9014	1	Pin-Locating
13	99-9022	1	Retainer-Seal
14	99-9007	1	Stud-Metric
16	107-9894	1	Kit-Label
17	99-9017	1	Filter-Oil
18	105-9337	1	Adapter-Filter, Oil
19	103-1384	1	Manual-Engine
20	99-9020	1	Nozzle-Oil
21	99-9021	1	Gasket-Retainer

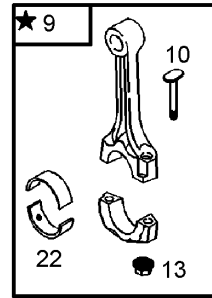
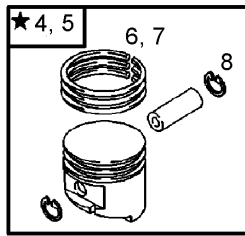
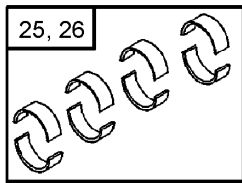
★ REQUIRES SPECIAL TOOLS TO INSTALL. SEE REPAIR INSTRUCTION MANUAL.

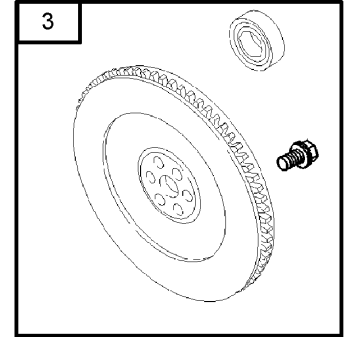
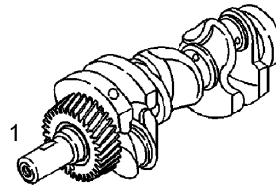
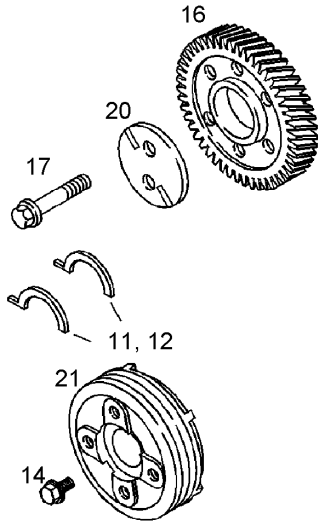
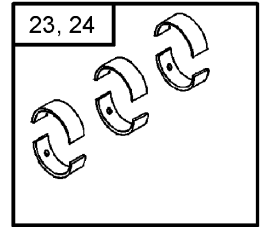

Assemblies include all parts shown in frames.

## Crankshaft Assembly

Ref	Part No.	Qty.	Description
1	105-9339	1	Crankshaft
3	99-9024	1	Flywheel
4	107-9895	1	Piston ASM
5	107-9896	1	Piston ASM (Oversize)
6	105-9340	1	Ring Set
7	99-9269	1	Ring Set (.010 In Oversized)
8	99-9607	1	Lock-Pin, Piston
9	99-9608	1	Rod-Connecting
10	99-9030	1	Screw-Rod, Connecting
11	99-9035	1	Washer-Thrust
12	99-9036	1	Washer-Thrust (.005 In Oversized)
13	99-9034	1	Nut-Hex
14	107-9897	1	Screw-Hex
15	99-9037	1	Pin-Locating
16	99-9609	1	Gear-Drive
17	99-9032	1	Screw-Hex
20	99-9040	1	Plate-Gear, Idler
21	99-9041	1	Pulley-Crankshaft
22	99-9042	1	Bearing-Rod
23	99-9043	1	Set-Bearing, Rod
24	99-9044	1	Set-Bearing, Rod (.010 Undersized)
25	99-9045	1	Set-Bearing, Main (Set Of 8)

Ref	Part No.	Qty.	Description
26	99-9046	1	Set-Bearing, Main (.010 Undersized)

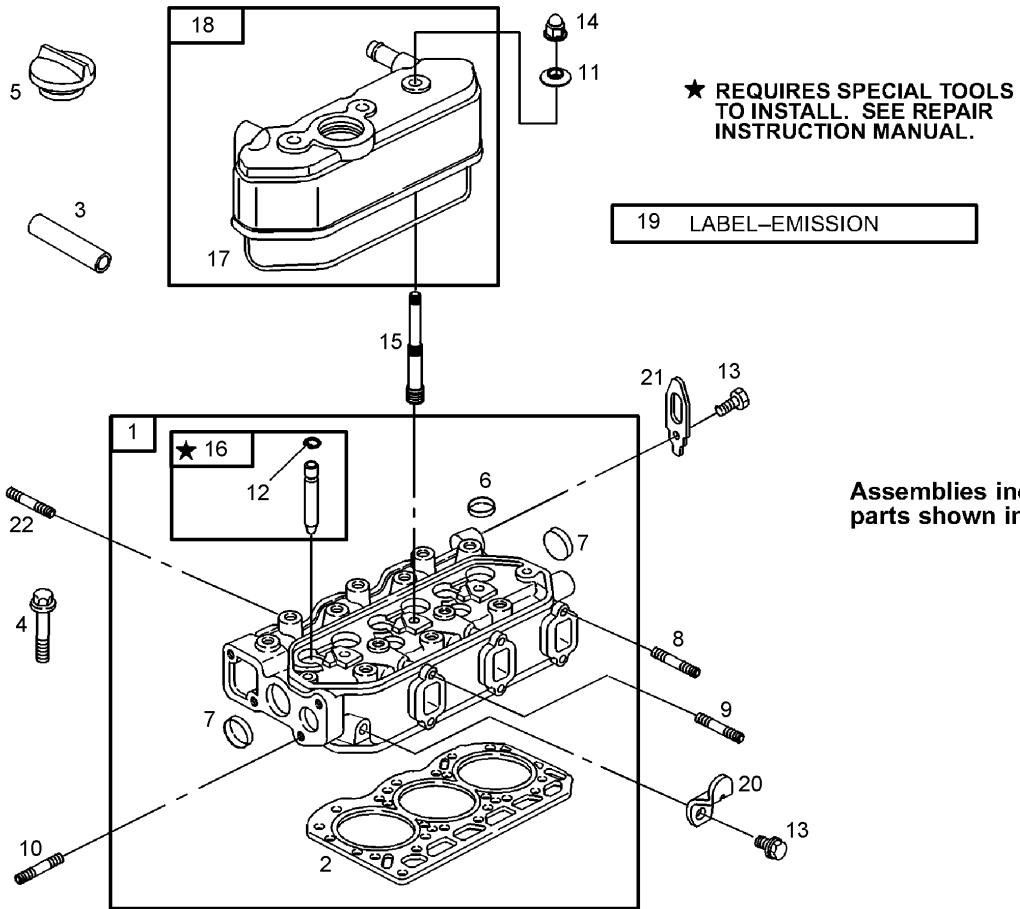

## Cylinder Head Assembly

Ref	Part No.	Qty.	Description
1	105-9341	1	Head-Cylinder
2	107-9898	1	Gasket-Head, Cylinder
3	105-9342	1	Tube-Breather
4	99-9614	1	Screw-Metric
5	99-9052	1	Cap-Fill, Oil
6	99-9060	1	Plug-Welch
7	99-9008	1	Plug-Welch
8	99-9058	1	Stud-Metric
9	99-9059	1	Stud-Metric
10	99-9057	1	Stud-Metric
11	99-9063	1	Washer-Seal
12	99-9067	1	Retainer
13	99-9054	1	Screw-Hex
14	99-9061	1	Nut-Hex, Metric
15	99-9101	1	Stud-Arm, Rocker
16	99-9070	1	Bushing-Guide
17	99-9073	1	Gasket-Cover, Rocker
18	100-6402	1	Cover-Rocker
19	107-9899	1	Emmision Label Kit
20	99-9076	1	Bracket-Lifting
21	99-9077	1	Bracket-Lifting
22	99-9055	1	Stud-Metric

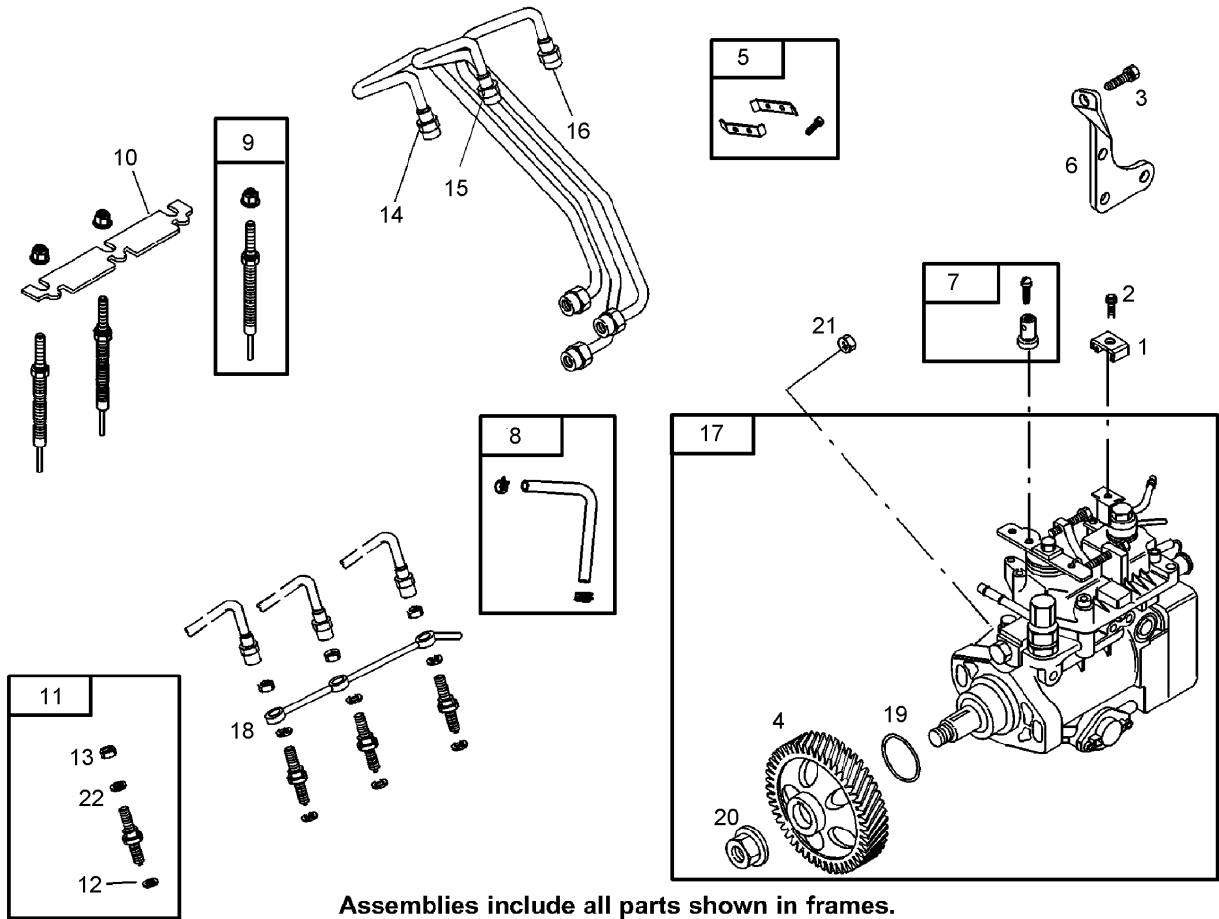



Assemblies include all parts shown in frames.

## Injection Pump Assembly

Ref	Part No.	Qty.	Description
1	99-9622	1	Clamp-Casing
2	99-9056	1	Screw-Hex
3	99-9616	1	Screw-Hex
4	99-9689	1	Gear-Drive
5	99-9625	1	Clamp
6	99-9626	1	Bracket-Support
7	99-9628	1	Clamp-Swivel
8	99-9629	1	Hose / Clamp ASM
9	99-9630	1	Plug-Glow
10	99-9631	1	Strap-Plug, Glow
11	99-9632	1	Nozzle-Injector
12	99-9633	1	Seat-Injector
13	105-9345	1	Nut
14	99-9690	1	Pipe-Injector, No. 1
15	99-9634	1	Pipe-Injector, No. 2
16	99-9635	1	Pipe-Injector, No. 3
17	105-9334	1	Pump-Injection
18	99-9637	1	Pipe-Return, Fuel
19	99-9618	1	O-Ring
20	99-9620	1	Nut-Hex, Metric
21	99-9619	1	Nut-Hex, Metric
22	105-9343	1	Seat-Injector

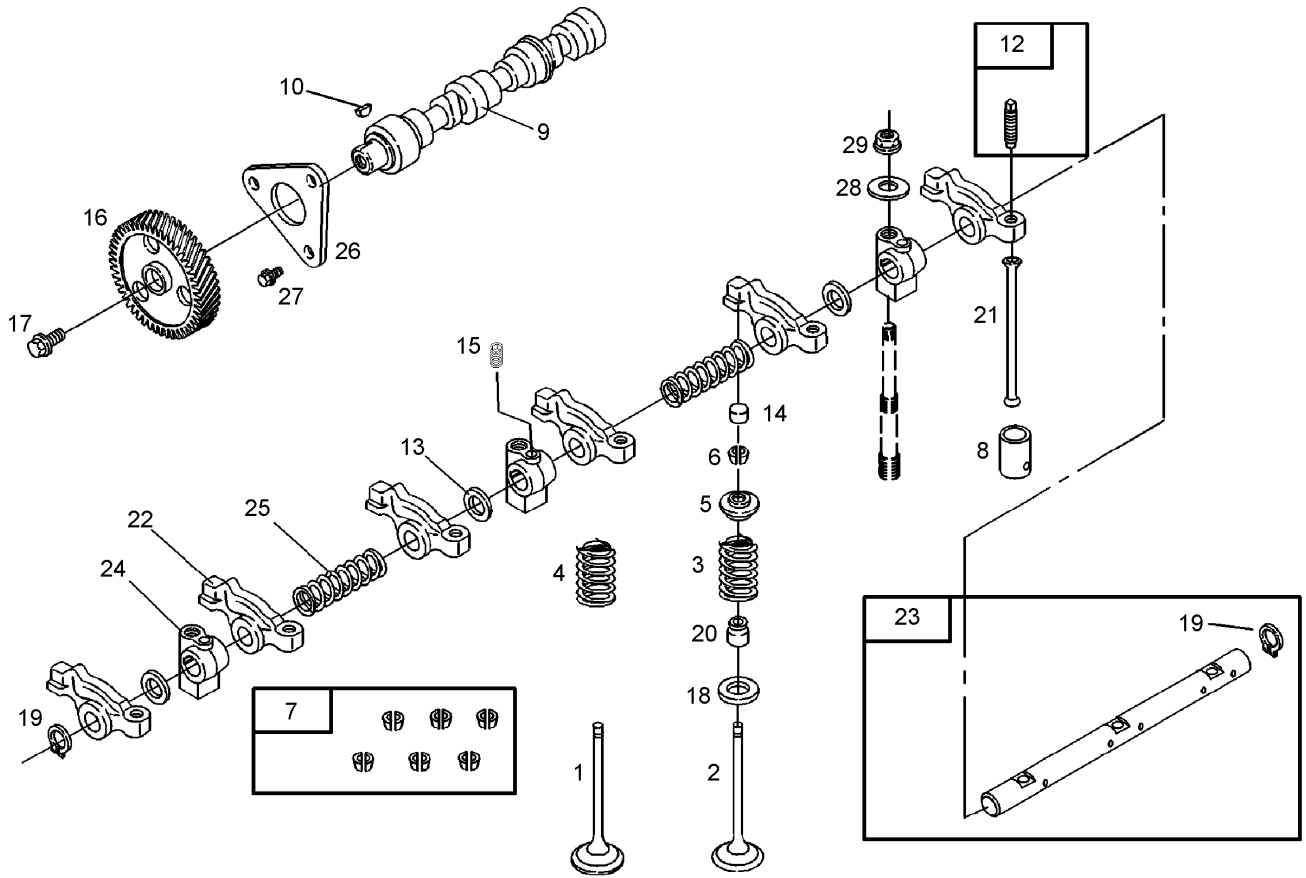
--	--	--	--



Assemblies include all parts shown in frames.

## Camshaft Assembly

Ref	Part No.	Qty.	Description
1	99-9638	1	Valve-Exhaust
2	99-9639	1	Valve-Intake
3	99-9640	1	Spring-Valve
4	99-9640	1	Spring-Valve
5	99-9084	1	Retainer-Valve
6	99-9086	1	Keeper-Valve
7	99-9087	1	Keeper-Valve (Set Of 6)
8	99-9088	1	Tappet-Valve
9	99-9097	1	Shaft-Cam
10	99-9675	1	Key-Timing
12	99-9092	1	Adjuster-Arm, Rocker
13	99-9093	1	Washer-Spacer
14	99-9094	1	Cap-Valve
15	99-9090	1	Screw-Metric
16	99-9641	1	Gear-Cam
17	99-9085	1	Screw-Metric
18	99-9096	1	Seat-Spring, Valve
19	99-9099	1	Retainer
20	99-9643	1	Seal-Valve
21	99-9103	1	Rod-Push
22	99-9104	1	Arm-Rocker
23	99-9106	1	Shaft-Arm, Rocker
24	99-9107	1	Support-Arm, Rocker
25	99-9108	1	Spring-Shaft, Rocker

Ref	Part No.	Qty.	Description
26	99-9109	1	Retainer-Camshaft
27	99-9083	1	Screw-Hex
28	99-9079	1	Washer-Flat
29	99-9091	1	Nut-Hex, Metric

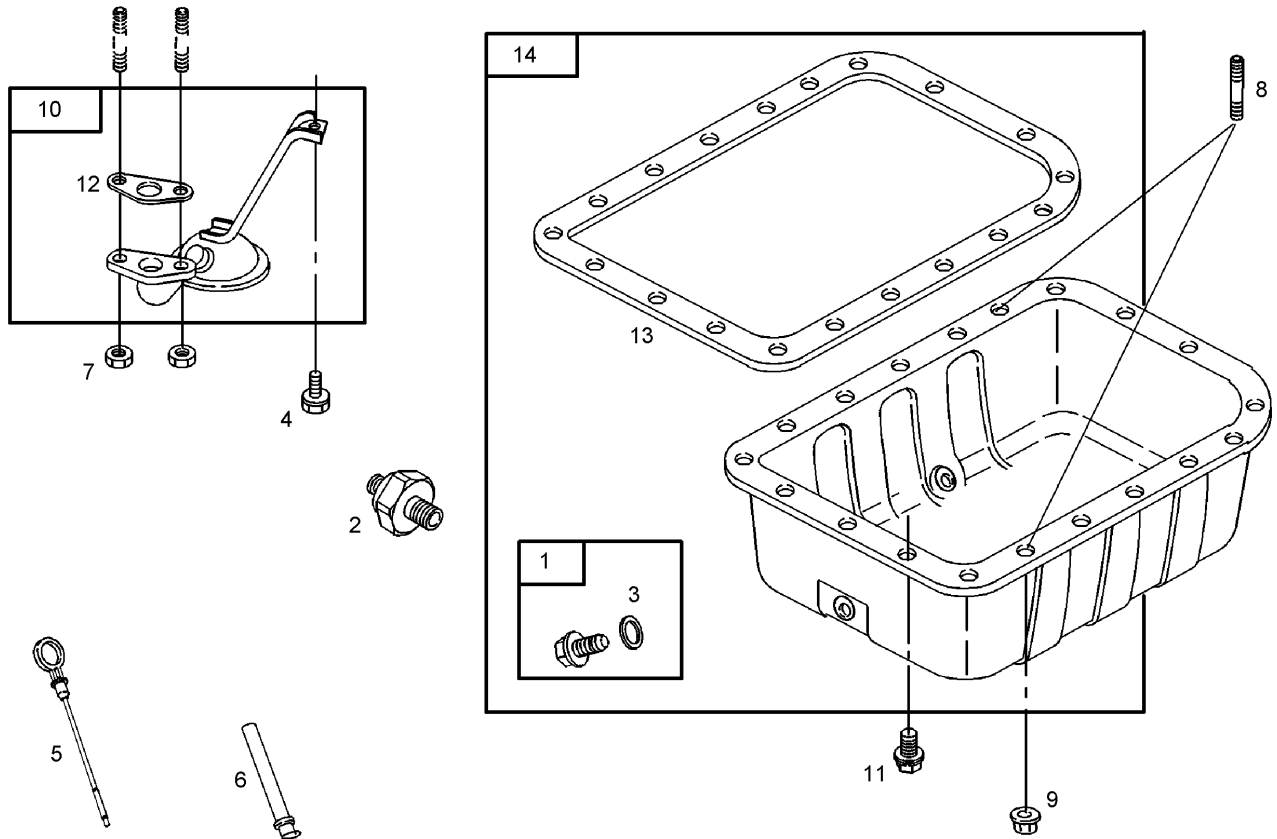

Assemblies include all parts shown in frames.

## Oil Pan Assembly

Ref	Part No.	Qty.	Description
1	99-9247	1	Plug-Drain, Oil
2	107-9908	1	Switch-Pressure, Oil
3	99-9249	1	Washer-Seal
4	99-9111	1	Screw-Hex
5	99-9272	1	Dipstick
6	99-9118	1	Tube-Dipstick
7	99-9114	1	Nut-Hex, Metric
8	99-9112	1	Stud-Metric
9	99-9113	1	Nut-Hex, Metric
10	99-9116	1	Screen-Pump, Oil
11	99-9111	1	Screw-Hex
12	99-9120	1	Gasket-Strainer, Oil
13	99-9121	1	Gasket-Pan, Oil
14	99-9241	1	Pan-Oil

--	--	--	--

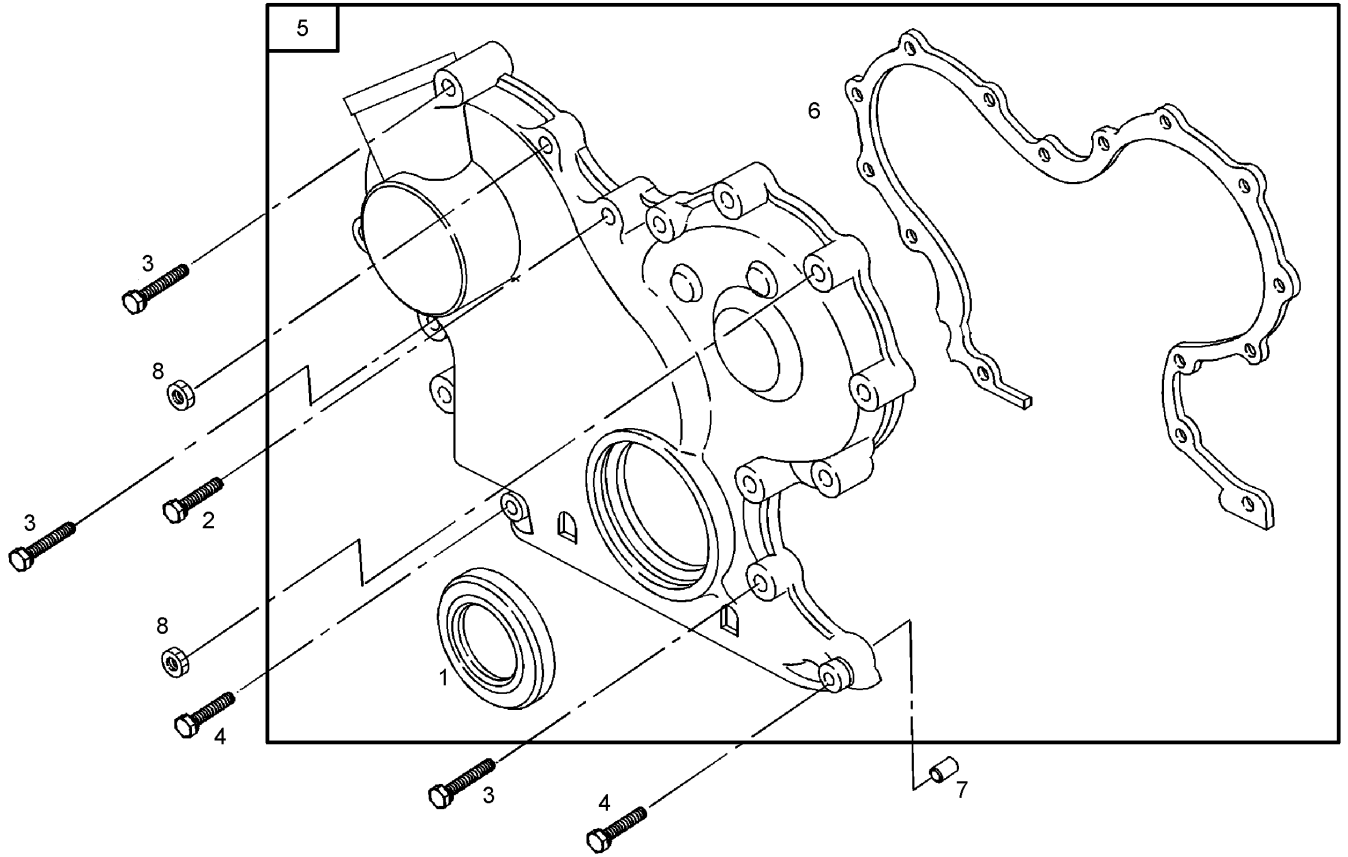

Assemblies include all parts shown in frames.

### Gear Cover Assembly

Ref	Part No.	Qty.	Description
1	107-9900	1	Seal-Oil
2	99-9651	1	Screw-Hex
3	99-9128	1	Screw-Hex
4	99-9129	1	Screw-Hex
5	99-9652	1	Gear Cover ASM
6	99-9653	1	Gasket-Cover, Gear
7	99-9014	1	Pin-Locating
8	99-9114	1	Nut-Hex, Metric

--	--	--	--

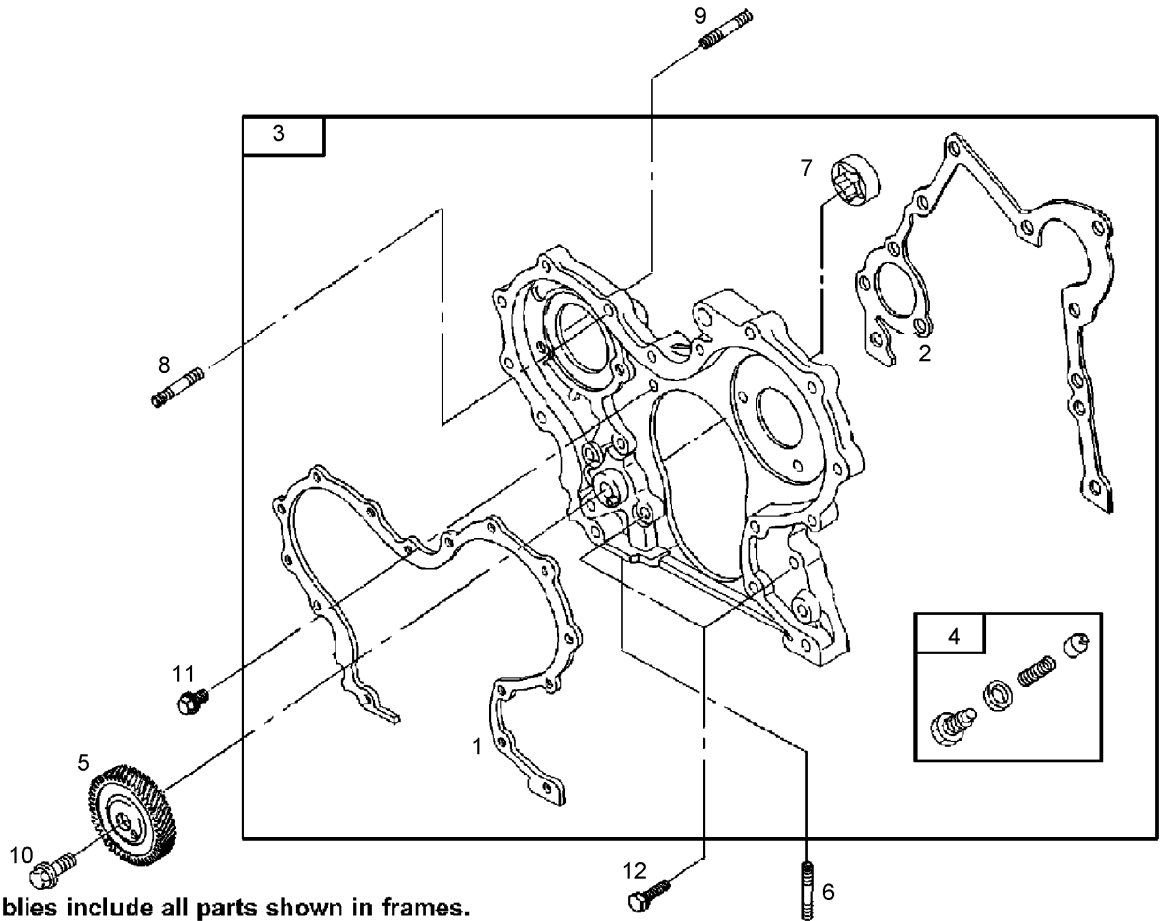

## Gear Housing Assembly

Ref	Part No.	Qty.	Description	
1	99-9653	1	Gasket-Cover, Gear	
2	99-9136	1	Gasket-Cover, Gear	
3	99-9655	1	Housing-Gear	
4	99-9142	1	Valve-Relief, Oil	
5	99-9656	1	Gear-Drive	
6	99-9007	1	Stud-Metric	
7		1	Pump-Oil	
8	99-9137	1	Stud-Metric	
9	99-9654	1	Stud-Metric	
10	99-9135	1	Screw-Hex	
11	99-9134	1	Screw-Hex	
12	99-9133	1	Screw-Hex	

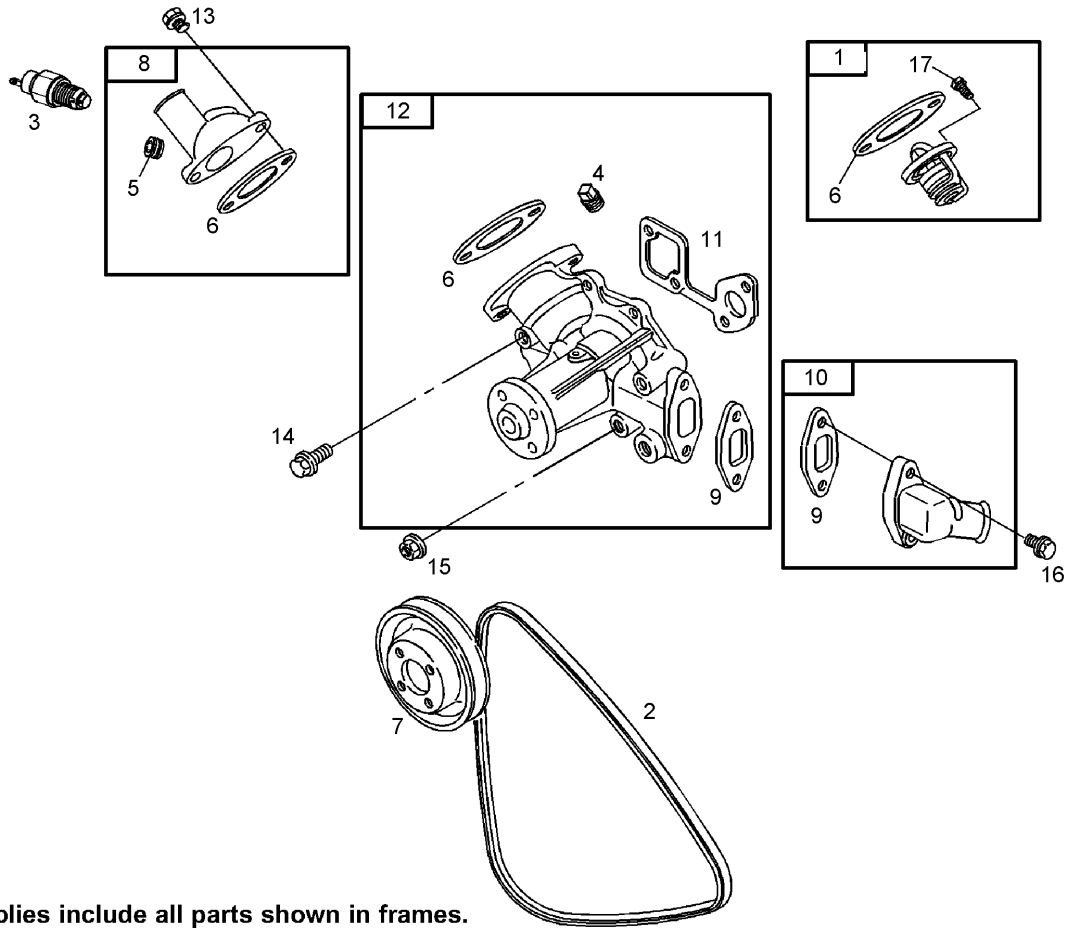

Assemblies include all parts shown in frames.

## Water Pump Assembly

Ref	Part No.	Qty.	Description
1	99-9155	1	Thermostat
2	99-9156	1	Belt-V
3	107-9902	1	Switch-Temperature, Water
4	99-9159	1	Plug
5	99-9158	1	Plug
6	99-9163	1	Gasket-Outlet
7	99-9164	1	Pulley-Pump
8	99-9165	1	Housing-Outlet
9	99-9166	1	Gasket-Housing, Inlet
10	99-9167	1	Housing-Inlet
11	99-9168	1	Gasket-Pump, Water
12	99-9659	1	Pump-Water
13	99-9004	1	Screw-Hex
14	99-9151	1	Screw-Hex
15	99-9153	1	Nut-Hex, Metric
16	99-9004	1	Screw-Hex
17	99-9152	1	Screw-Metric

--	--	--	--





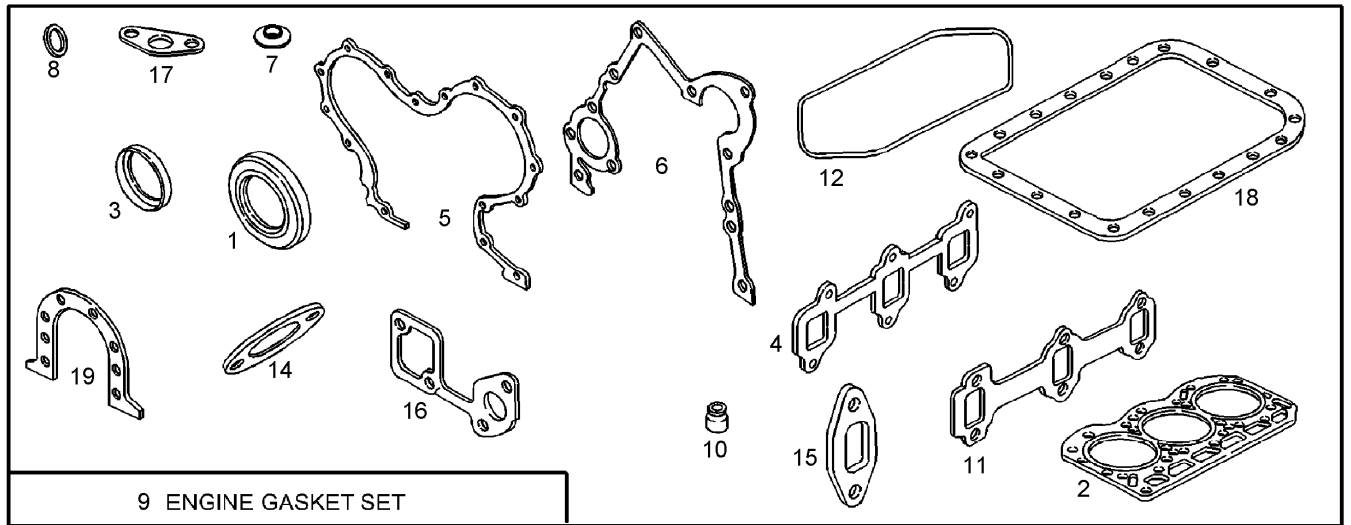

9 ENGINE GASKET SET

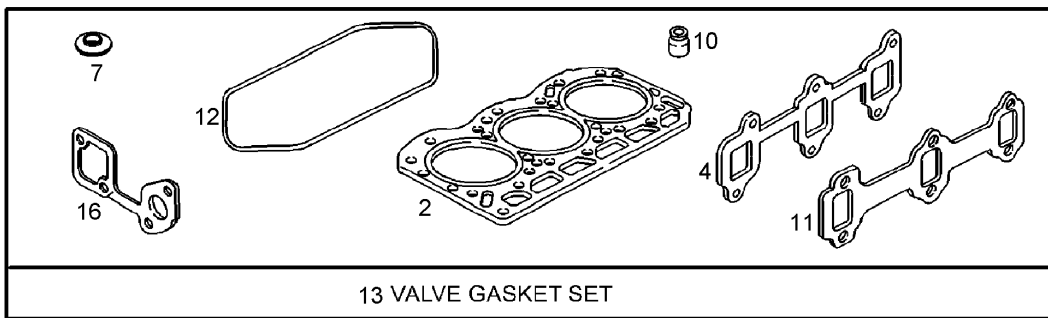

13 VALVE GASKET SET

Assemblies include all parts shown in frames.

## Gasket Assembly

Ref	Part No.	Qty.	Description
1	99-9003	1	Seal-Oil
2	107-9898	1	Gasket-Head, Cylinder
3	107-9900	1	Seal-Oil
4	99-9662	1	Gasket-Intake
5	99-9653	1	Gasket-Cover, Gear
6	99-9136	1	Gasket-Cover, Gear
7	99-9063	1	Washer-Seal
8	99-9249	1	Washer-Seal
9	107-9906	1	Gasket Set
10	99-9643	1	Seal-Valve
11	106-1855	1	Gasket-Exhaust
12	99-9073	1	Gasket-Cover, Rocker
13	107-9907	1	Valve Overhaul Kit
14	99-9163	1	Gasket-Outlet
15	99-9166	1	Gasket-Housing, Inlet
16	99-9168	1	Gasket-Pump, Water
17	99-9120	1	Gasket-Strainer, Oil
18	99-9121	1	Gasket-Pan, Oil
19	99-9021	1	Gasket-Retainer

--	--	--	--

## NOTES

# NOTES

# NOTES

