



## Z500 Z Master<sup>®</sup> With 52in 7-Gauge Side Discharge Mower

Model No. 74248 - 260000001 and up.

### Parts Catalog

---

#### Ordering Replacement Parts

To order replacement parts, please supply the part number, the quantity, and the description of each part desired.

#### Understanding Reference Numbers

Each Identified part in an illustration has a reference number. The reference number for a part also appears in the parts list, along with other information about the part.

This catalog uses two special reference number formats, one to indicate parts in a service assembly and another to indicate the quantity of a given part in an illustration.

#### Service Assembly Reference Numbers

Parts in service assemblies have reference numbers in the form a:b. The a represents the reference number of the entire service assembly and the b represents a sequential number unique to each part within the service assembly.

For example, a wheel assembly might be identified by reference number 6, the tire by 6:1, the valve by 6:2, and the wheel by 6:3. When you order the assembly identified by reference number 6, you receive all parts identified by reference numbers 6:1, 6:2, and 6:3. However, you may also order any part individually. Reference numbers of this type appear in illustrations and in part lists.

#### Reference Numbers Indicating Quantity

In an illustration, if a reference number indicates more than one part, the reference number has the form nX y. The n represents the quantity of the part, the X is the multiplication symbol, and the y represents the reference number.

For example, in an illustration, the reference number 2X 37 means that two of the parts identified by reference number 37 are indicated.

# Contents

Description	Page	Description	Page
Front Frame Assembly	3	Cylinder and Crankcase Assembly Kawasaki FH721D-CS05-R	23
Caster and Wheel Assembly	4	Piston and Crankshaft Assembly Kawasaki FH721D-CS05-R	25
Main Frame Assembly	5	Valve and Camshaft Assembly Kawasaki FH721D-CS05-R	27
Brake and Wheel Hub Assembly	6	Lubrication Equipment Assembly Kawasaki FH721D-CS05-R	29
Steering Control Assembly	7	Cooling Equipment Assembly Kawasaki FH721D-CS05-R	31
Hydraulic System Assembly	8	Electric Equipment Assembly Kawasaki FH721D-CS05-R	33
Seat and Roll-Over-Protection-System Assembly	10	Control Equipment Assembly Kawasaki FH721D-CS05-R	35
Seat Assembly No. 110-0442	11	Carburetor Assembly Kawasaki FH721D-CS05-R	37
Roll-Over-Protection-System Assembly No. 108-1097	12	Air Filter and Muffler Assembly Kawasaki FH721D-CS05-R	39
Deck Connection Assembly	13	Fuel Tank and Valve Assembly Kawasaki FH721D-CS05-R	41
Drive Idler Assembly	14	Power-Take-Off Equipment Assembly Kawasaki FH721D-CS05-R	44
Engine and Clutch Assembly	15	Label Assembly Kawasaki FH721D-CS05-R	45
Muffler and Guard Assembly	16	Attachments and Accessories List	46
Fuel Tank Assembly	17		
Electrical Assembly	18		
52 Inch Deck Assembly	19		
Spindle Assembly No. 107-8504	20		
Deck Assembly No. 110-5551	21		
Rubber Deflector Assembly No. 108-7770	22		
Starter Assembly Kawasaki FH721D-CS05-R	43		

## Part Description Abbreviations

Part descriptions in this catalog may include the following abbreviations.

AR. .... as required	INC. .... incorporated
ASM. .... assembly	LH. .... left hand
BBC. .... blade brake clutch	NI. .... nylon insert
CARR. .... carriage	NPTF. .... national pipe thread fine
DEG. .... degrees	PFH. .... phillips flat head
EXT. .... external	PPH. .... phillips pan head
FH. .... flat head	PPHTF. .... phillips pan head thread forming
GA. .... gauge	PRH. .... phillips round head
HF. .... hex flange	PTH. .... phillips truss head
HH. .... hex head	PTO. .... power-take-off
HHF. .... hex head flange	RH. .... right hand
HHFTF. .... hex head flange thread forming	ROPS. .... roll-over-protection-system
HJ. .... hex jam	SFH. .... slotted fillister head
HLH. .... hex lag head	SHH. .... slotted hex head
HOC. .... height-of-cut	SHWH. .... slotted hex washer head
HSBH. .... hex socket button head	SPH. .... slotted pan head
HSFH. .... hex socket flat head	SQH. .... square head
HSH. .... hex socket head	SRH. .... slotted round head
HWH. .... hex washer head	STD. .... standard
HWHTF. .... hex washer head thread forming	TAP. .... self tapping
HYD. .... hydraulic	TTH. .... torx truss head

## Footnotes

- ❶ Not illustrated
- ❷ Obtain from your local Kawasaki dealer

- ❸ Not serviced separately

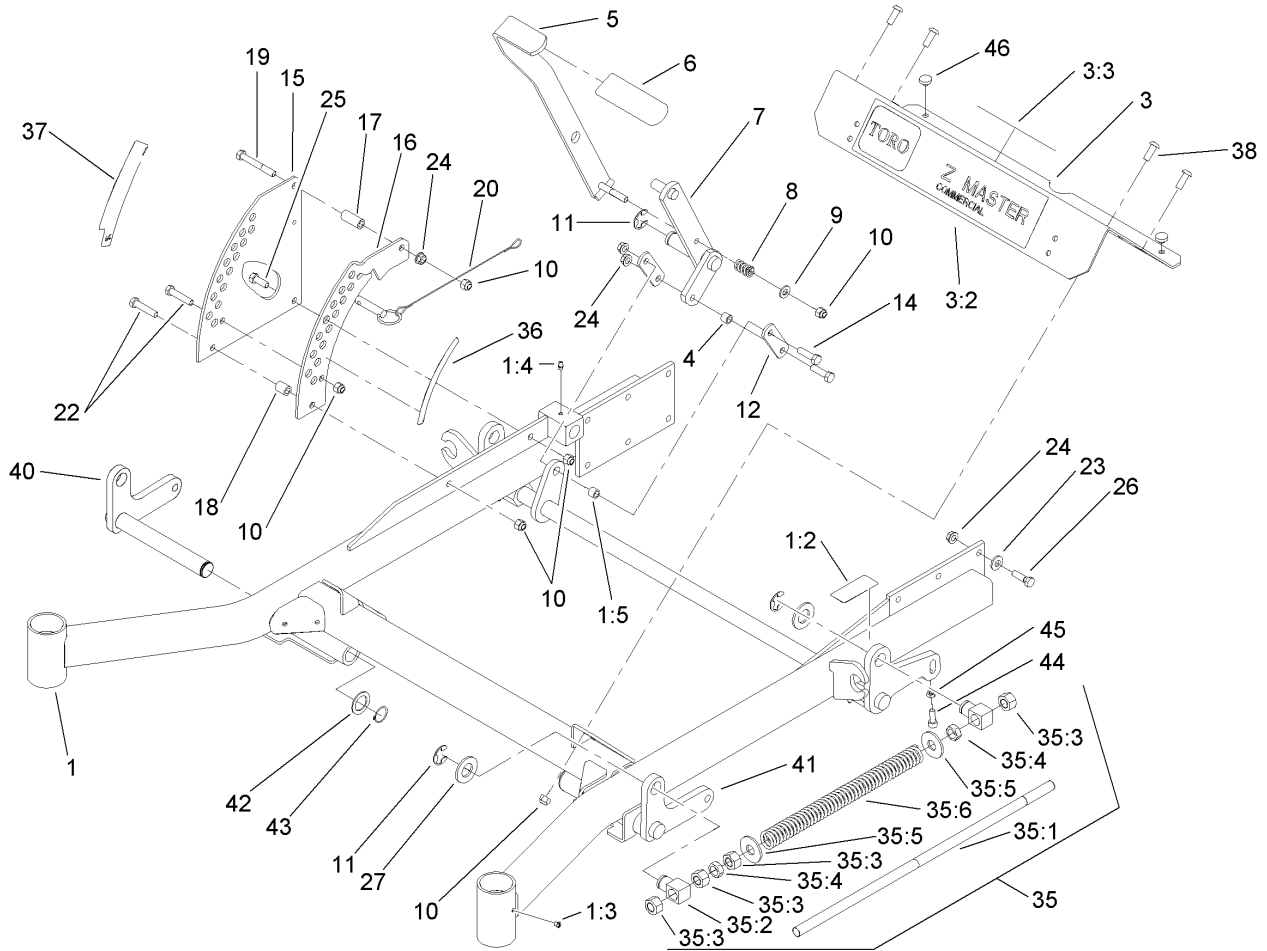

## Front Frame Assembly

Ref	Part No.	Qty.	Description
1	106-8978	1	Frame ASM
1:2	107-1857	1	Decal-Brake, Parking
1:3	1-811010	2	Plug
1:4	302-19	5	Fitting-Grease
1:5	103-1918	1	Bushing
3	106-9981	1	Front Floorpan ASM
3:2	106-7451	1	Decal
3:3	107-2112	1	Decal-Warning
4	103-1918	1	Bushing
5	103-2083-03	1	Lift Lever ASM
6	1-633295	1	Grip-Lever, Lift
7	103-2064-03	1	Arm-Lift, Deck
8	1-633325	1	Spring-Compression
9	3256-24	1	Washer-Flat
10	3296-39	9	Nut-Lock, NI
11	32151-103	5	Ring-Snap
12	1-633068	2	Arm-Lift, Deck
14	323-29	2	Screw-HH
15	1-633889-01	1	Plate-Lift, Deck
16	108-7759-01	1	Plate-Lift, Deck
17	1-633082	1	Bushing-Lever, Lift
18	1-633080	1	Bushing-Lever, Lift
19	323-13	1	Screw-HH
20	106-9951	1	Hitch Pin ASM

Ref	Part No.	Qty.	Description
22	323-9	2	Screw-HH
23	98-5975	12	Washer-Belleville
24	3290-357	15	Nut-HHF, Whiz
25	323-6	1	Screw-HH
26	323-7	12	Screw-HH
27	3256-29	4	Washer-Flat
35		2	Front Frame Spring ASM
35:1	1-633096	1	Rod-Lift, Deck
35:2	1-633441	2	Swivel-Deck Mount, Rear
35:3	3217-11	4	Nut-Hex
35:4	3218-6	2	Nut-Jam
35:5	3256-7	2	Washer-Flat
35:6	1-633064	1	Spring-Support, Deck
36	107-1861	1	Decal-Height, Deck
37	107-1860	1	Decal-Height, Deck
38	3274-94	4	Screw-HSBH
40	110-4156-01	1	RH Deck Lift ASM
41	106-8984-01	1	LH Deck Lift ASM
42	1-523157	2	Washer-Spacer, 14 GA
43	32151-29	2	Ring-Retaining
44	3274-18	2	Screw-HSH
45	3218-2	2	Nut-Jam
46	1-513658	2	Bumper

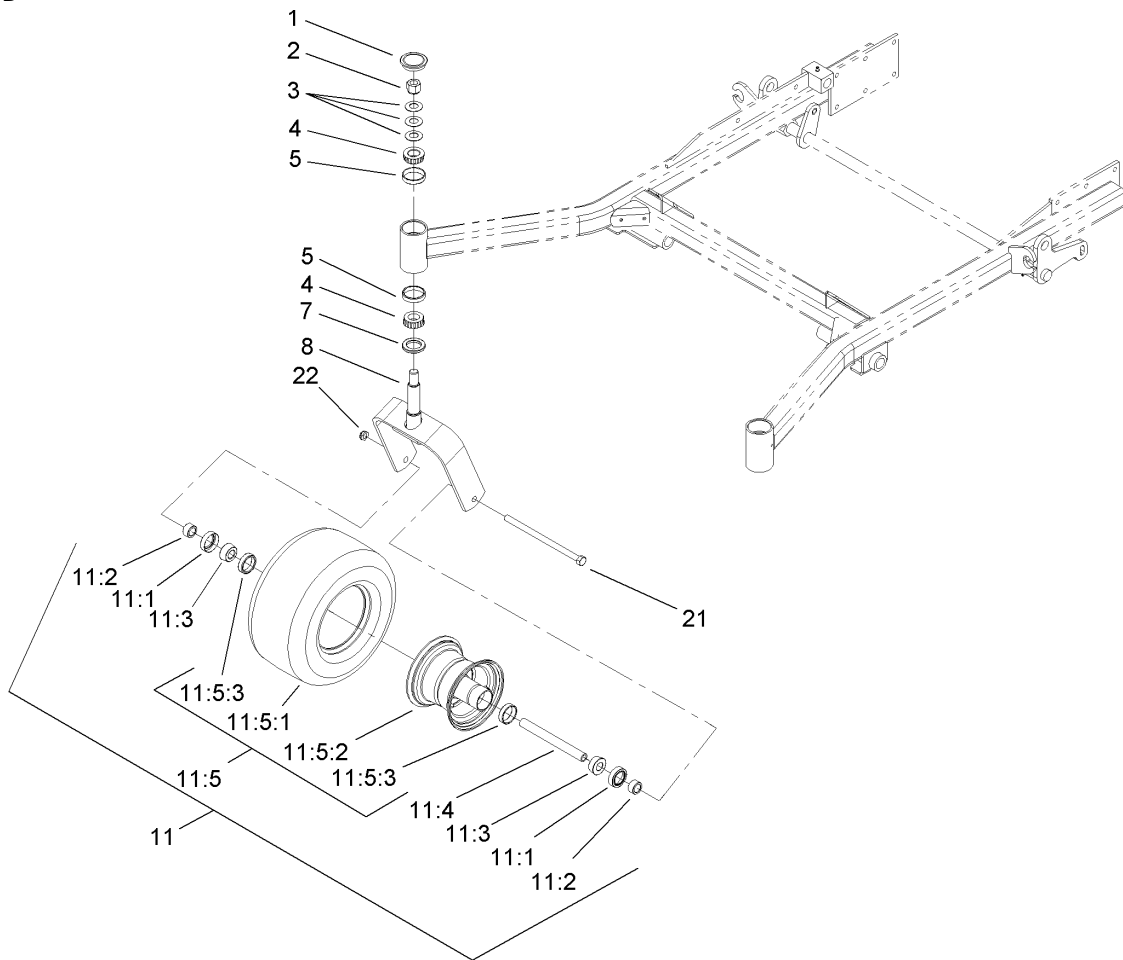

## Caster and Wheel Assembly

Ref	Part No.	Qty.	Description
1	103-4882	2	Cap-Grease
2	3296-51	2	Nut-Lock, NI
3	1-633508	6	Washer-Bellville
4	254-94	4	Bearing-Cone, Tapered
5	254-72	4	Bearing-Cup, Tapered
7	1-543511	2	Seal-Grease
8	1-642111-01	2	Caster
11	1-644251	2	Caster Wheel ASM
11:1	1-633580	2	Seal-Bearing
11:2	1-633581	2	Spacer-Bearing
11:3	1-633585	2	Bearing-Cone, Taper
11:4	1-633959	1	Spacer-Caster, Front
11:5		1	Wheel And Tire ASM
11:5:1	1-523009	1	Tire
11:5:2	1-633987	1	Wheel
11:5:3	1-633584	2	Bearing-Cup
21	325-24	2	Screw-HH
22	3296-45	2	Nut-Lock, NI

Ref	Part No.	Qty.	Description

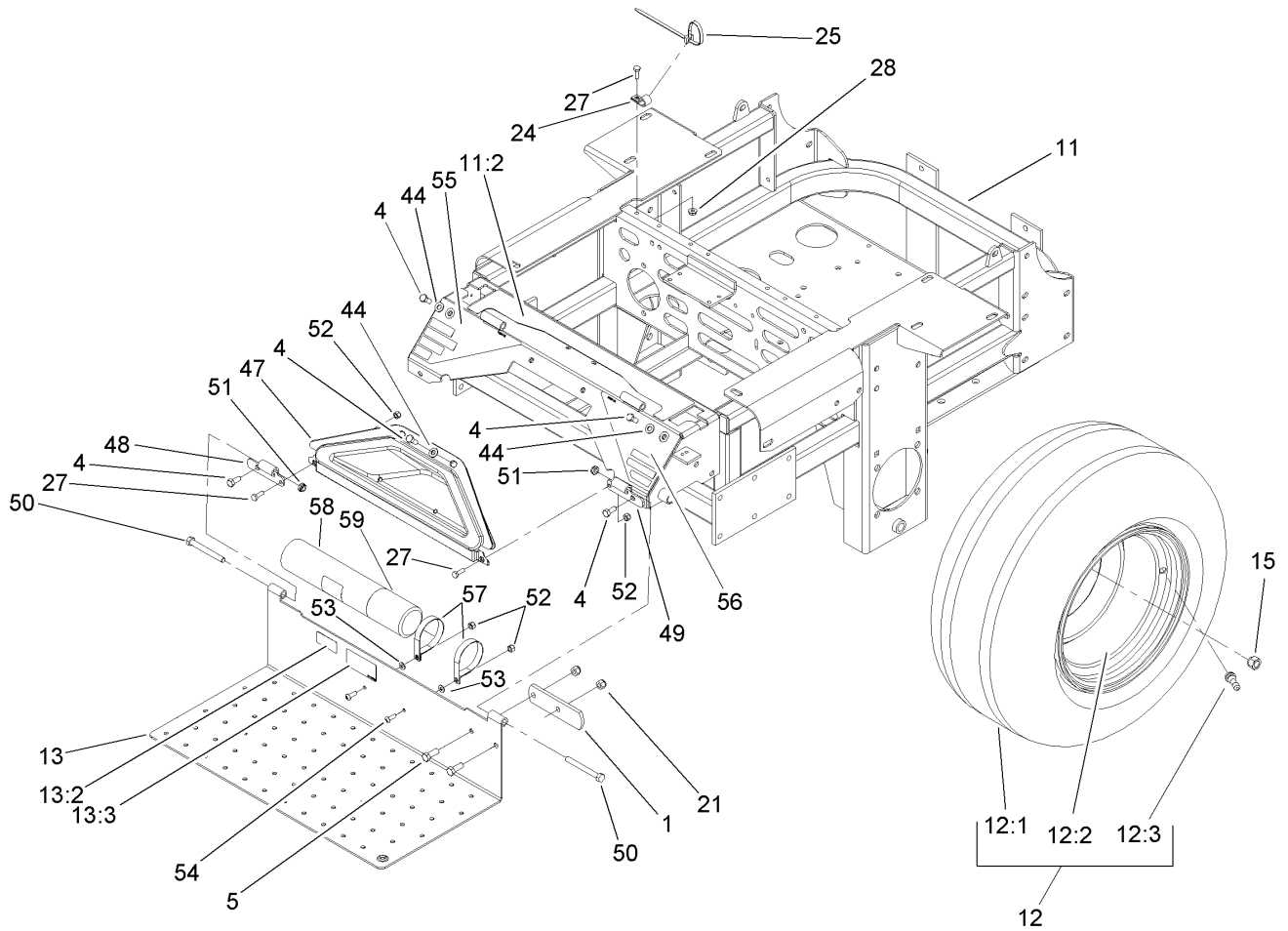

## Main Frame Assembly

Ref	Part No.	Qty.	Description
1	1-633964-03	1	Stop-Brake, Park
4	322-43	6	Screw-HH
5	323-6	2	Screw-HH
11	108-1095	1	Main Frame ASM
11:2	107-8076	1	Decal-Console, Top
12	1-653010	2	Wheel And Tire ASM
12:1	1-653160	1	Tire
12:2	1-653158	1	Wheel
12:3	232-27	1	Stem-Valve
13	107-1858	1	Floorpan
13:2	98-4387	1	Decal-Protection, Ear
13:3	107-1864	1	Decal-Location, Manual
15	242-50	8	Nut-Lug
21	3296-39	2	Nut-Lock, NI
24	1-513762	1	Clip-Loom
25	1-303335	1	Tie-Plastic
27	321-4	3	Screw-HH
28	32128-33	1	Nut-HF
44	3256-70	6	Washer-Flat
47	106-7498	1	Pocket
48	106-7488-03	1	Hinge-Floorpan, LH
49	106-7489-03	1	Hinge-Floorpan, RH
50	323-20	2	Screw-HH
51	3296-59	2	Nut-Lock, NI

Ref	Part No.	Qty.	Description
52	3296-42	4	Nut-Lock, NI
53	3256-63	2	Washer-Flat
54	3258-166	2	Screw-PRH
55	106-9989	1	Decal-Warning
56	106-7492	1	Decal-Danger
57	107-1865	2	R-Clamp
58	104-7050	1	Housing-Manual
59	104-7048	1	Cap-Housing

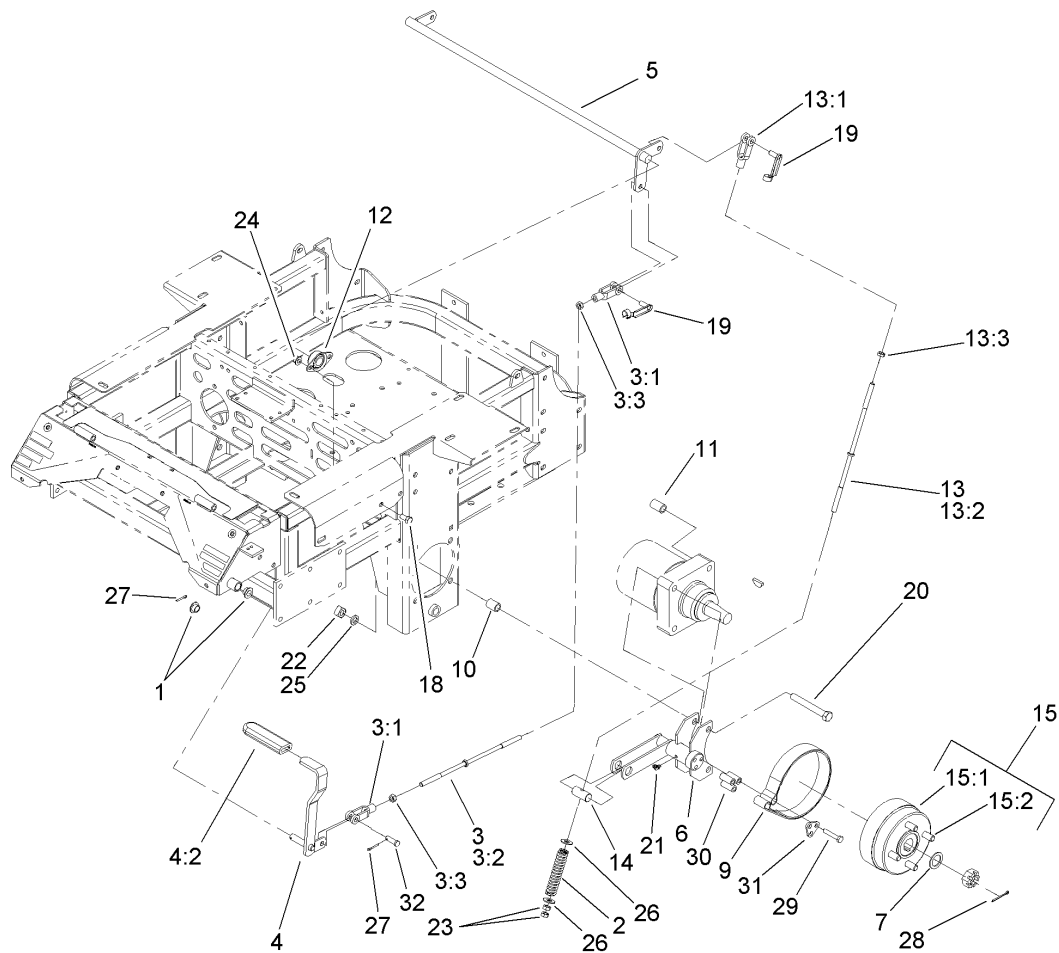

## Brake and Wheel Hub Assembly

Ref	Part No.	Qty.	Description
1	1-513140	2	Bearing-Control
2	1-633454	2	Spring-Brake
3	103-4332	1	Brake Rod And Yoke ASM
3:1	1-633131	2	Yoke-Linkage, Brake
3:2	1-633477	1	Rod-Brake
3:3	3219-3	2	Nut-Hex
4	1-634500	1	Brake Lever ASM
4:2	1-633268	1	Grip-Lever, Brake
5	1-632217-03	1	Shaft-Brake
6	103-0352-03	2	Bracket-Brake
7	1-523157	2	Washer-Spacer, 14 GA
9	103-0355	2	Band-Brake
10	1-633380	4	Spacer-Wheel, Short
11	1-633382	4	Spacer-Wheel, Long
12	1-633102	2	Bearing-Flange, Side
13	103-4333	2	Brake Rod And Yoke ASM
13:1	1-633131	1	Yoke-Linkage, Brake
13:2	1-633477	1	Rod-Brake
13:3	3219-3	1	Nut-Hex
14	1-633144	2	Pin-Trunion
15	103-0590	2	Hub And Wheel ASM
15:1	103-0589	1	Wheel Hub ASM
15:2	1-633926	4	Stud-Wheel
18	323-4	4	Screw-HH

Ref	Part No.	Qty.	Description
19	103-2399	3	Pin-Spring, Clevis
20	325-17	8	Screw-HH
21	1481	2	Fitting-Grease
22	103-0131	8	Nut-Square
23	3219-3	4	Nut-Hex
24	3290-357	4	Nut-HHF, Whiz
25	3253-7	8	Washer-Lock
26	3256-4	4	Washer-Flat
27	3272-10	2	Pin-Cotter
28	1-806800	2	Pin-Cotter
29	322-9	6	Screw-HH
30	103-0384	6	Spacer
31	103-0374	2	Retainer-Band, Brake
32	1-808285	1	Pin-Clevis

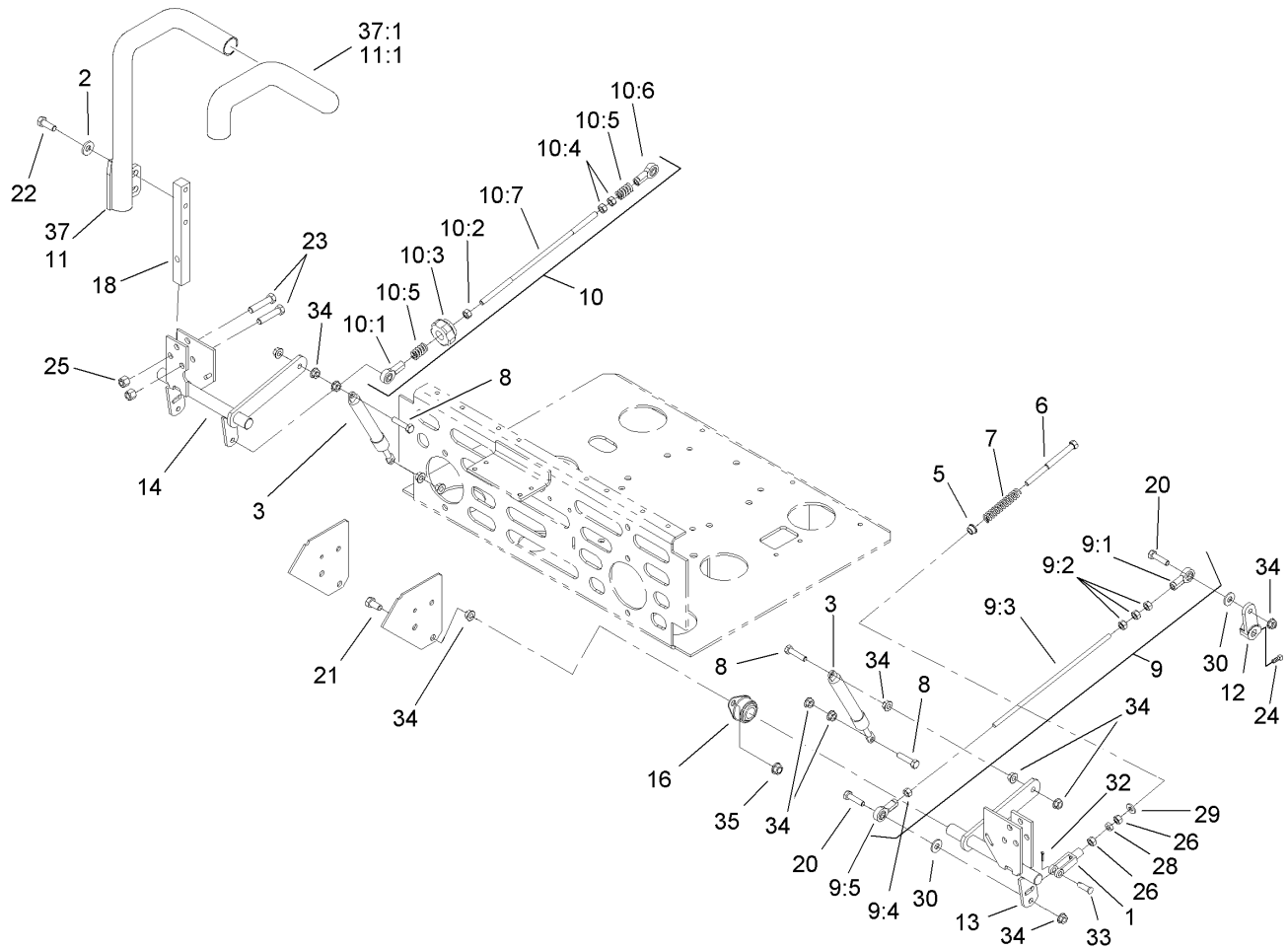

## Steering Control Assembly

Ref	Part No.	Qty.	Description
1	1-303105	2	Yoke-Adjustable
2	98-5975	4	Washer-Belleville
3	103-4079	2	Damper-Control, Motion
5	1-603735	2	Bushing-Flanged
6	1-603737	2	Bolt-Return, Neutral
7	1-603807	2	Spring-Return, Neutral
8	1-403180	4	Screw-HH
9	103-4331	1	Tracking Rod ASM
9:1	1-543017	1	Balljoint-RH
9:2	3219-2	3	Nut-Hex
9:3	103-3064	1	Link-Rod, Tracking
9:4	1-804524	1	Nut
9:5	1-633152	1	Balljoint-Thread, LH
10	103-4330	1	Tracking Rod ASM
10:1	1-543017	1	Balljoint-RH
10:2	3219-2	1	Nut-Hex
10:3	103-3060	1	Knob-Tracking
10:4	1-804524	2	Nut
10:5	1-323245	2	Spring-Compression
10:6	1-633152	1	Balljoint-Thread, LH
10:7	103-3064	1	Link-Rod, Tracking
11	103-0631	1	LH Lever ASM
11:1	1-633257	1	Grip-Control, Motion
12	1-632208	2	Arm-Control, Pump

Ref	Part No.	Qty.	Description
13	103-4781	1	Control-Motion, LH
14	103-4782	1	Control-Motion, RH
16	1-633102	4	Bearing-Flange, Side
18	103-0407	2	Arm-Shaft, Control
20	322-6	4	Screw-HH
21	323-4	8	Screw-HH
22	323-6	4	Screw-HH
23	323-9	6	Screw-HH
24	1-803022	2	Screw-Set
25	3296-39	6	Nut-Lock, NI
26	3219-2	4	Nut-Hex
28	3220-2	2	Nut-Jam
29	3256-2	2	Washer-Flat
30	3256-3	4	Washer-Flat
32	3272-5	2	Pin-Cotter
33	1-808280	2	Pin-Clevis
34	32128-20	16	Nut-HF
35	3290-357	8	Nut-HHF, Whiz
37	103-0632	1	RH Lever ASM
37:1	1-633257	1	Grip-Control, Motion

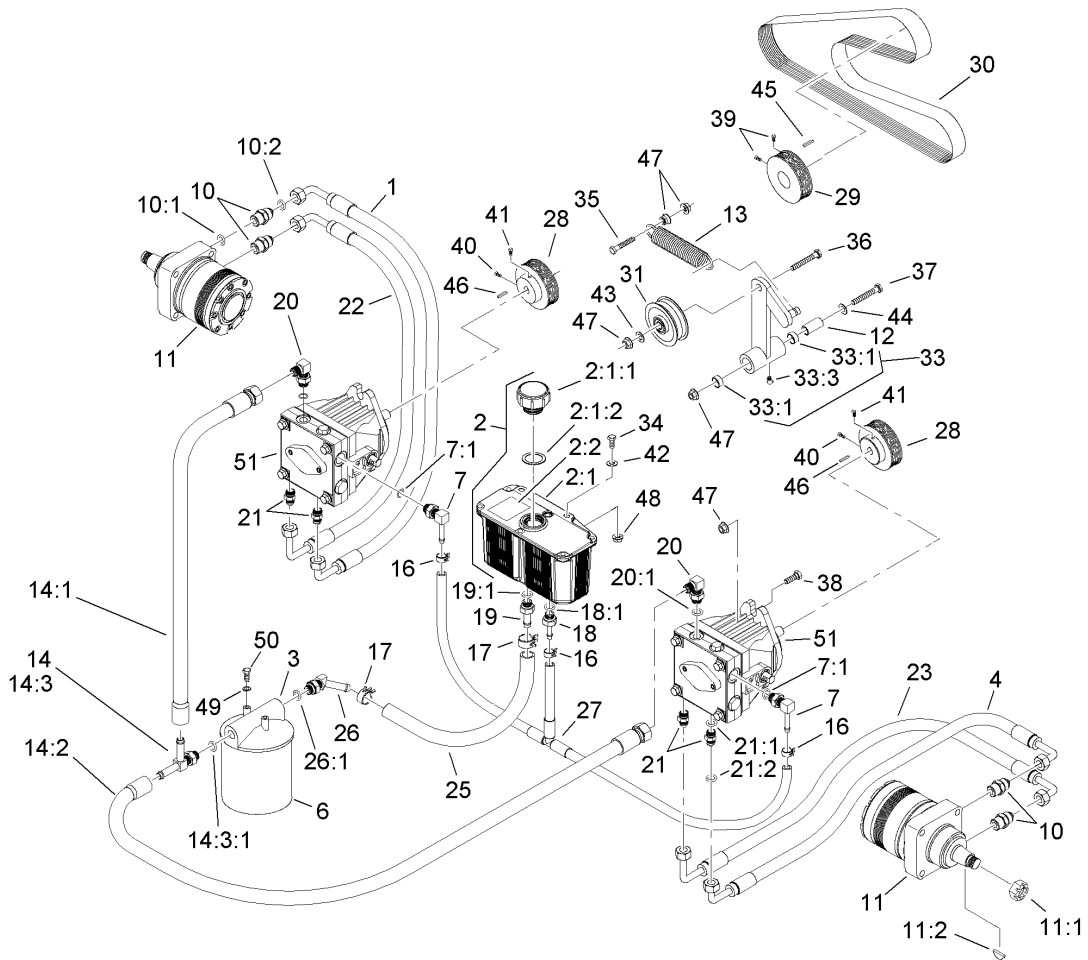

## Hydraulic System Assembly

Ref	Part No.	Qty.	Description
1	103-3736	1	HYD Hose ASM
2	103-1947	1	HYD Reservoir ASM
2:1		1	Reservoir-HYD
2:1:1	103-1948	1	Cap-Reservoir, HYD
2:1:2	103-1949	1	Gasket-Cap
2:2	1-523552	1	Decal-Tank, HYD
3	104-7836	1	Head-Filter
4	103-3733	1	HYD Hose ASM
6	1-633750	1	Filter-HYD
6	1-633752	1	Filter-HYD, Winter
7	103-1799	2	Elbow-90 DEG
7:1	237-42	1	O-Ring
10	1-603991	4	Fitting-Straight
10:1	237-80	1	O-Ring
10:2	1-603992	1	O-Ring
11	103-6988	2	Motor-Wheel
11:1	1-809036	1	Nut-HH
11:2	3257-42	1	Key-Woodruff
11:99	1-000099	1	Seal Kit
11:99	1-000139	1	Bearing Kit
11:99	103-2748	1	Drive Link Kit
12	1-603384	1	Bushing-Pivot, Idler
13	103-3330	1	Spring-Extension
14	109-1936	1	Pump Inlet Hose ASM

Ref	Part No.	Qty.	Description
14:1	103-1826	1	HYD Hose ASM
14:2	103-1827	1	HYD Hose ASM
14:3	103-1828	1	Adapter-Run, Tee
14:3:1	237-42	1	O-Ring
16	103-1716	3	Clamp-Hose
17	103-1988	2	Clamp-Hose
18	103-1801	1	Adapter-Straight
18:1	237-42	1	O-Ring
19	103-1912	1	Adapter-Straight
19:1	237-42	1	O-Ring
20	103-1802	2	Fitting-HYD, 90 DEG
20:1	1-603921	1	O-Ring
21	1-603990	4	Fitting-Straight
21:1	1-603920	1	O-Ring
21:2	1-603992	1	O-Ring
22	103-3737	1	HYD Hose ASM
23	103-3735	1	HYD Hose ASM
25	103-1808	1	Hose-HYD
26	103-1807	1	Elbow-45 DEG
26:1	237-42	1	O-Ring
27	103-1806	1	HYD Hose ASM
28	103-6907	2	Sheave
29	1-633567	1	Sheave
30	103-7445	1	Belt-V





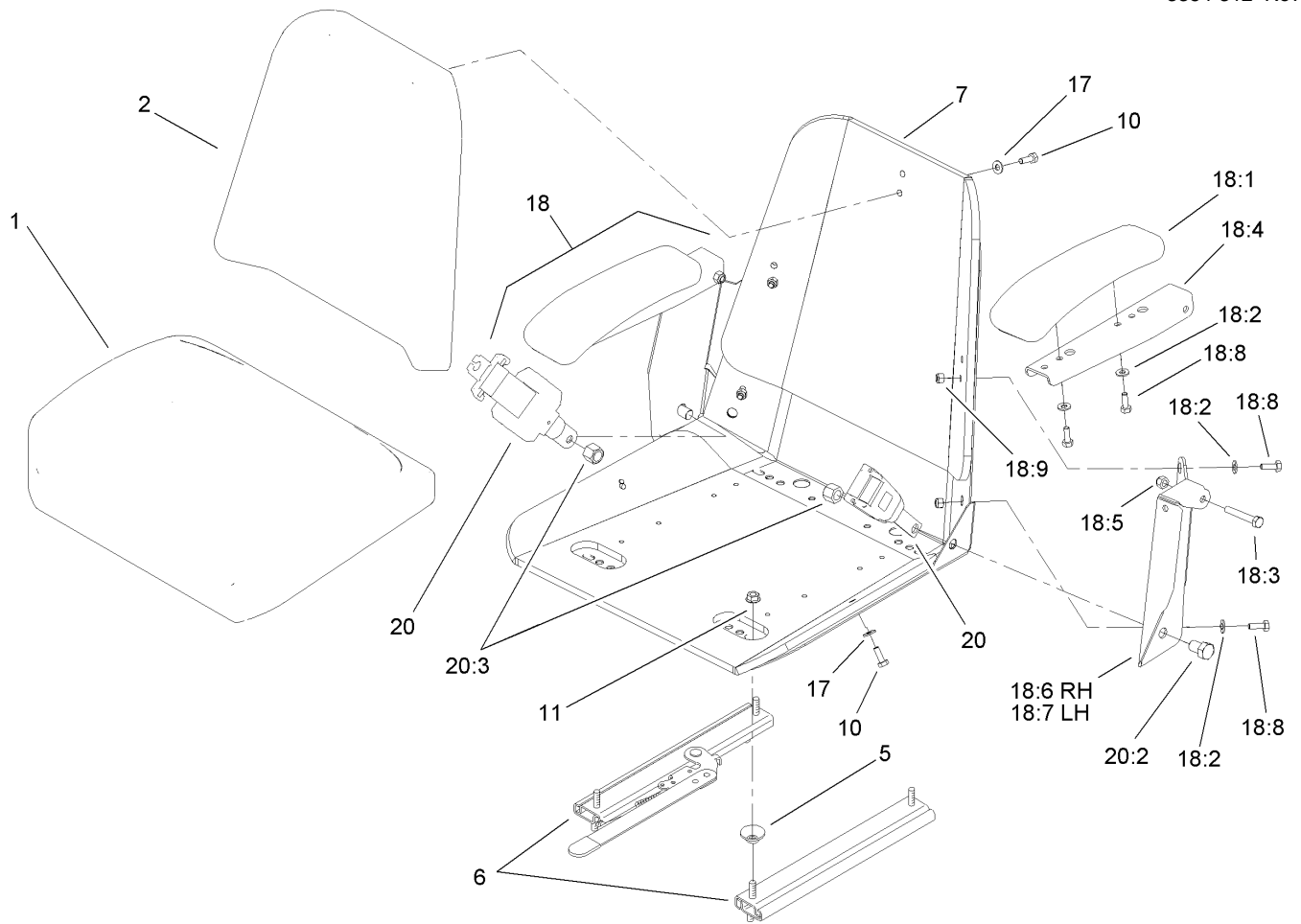

### Seat Assembly No. 110-0442

Ref	Part No.	Qty.	Description
1	103-0290	1	Cushion-Seat, Bottom
2	104-7754	1	Cushion-Seat, Back
5	1-543401	4	Spacer-Track
6	1-643255	1	Track-Seat
7	1-633859	1	Frame-Seat
10	321-30	11	Screw-HH
11	32128-20	4	Nut-HF
17	3256-22	11	Washer-Flat
18	105-3620	1	Armrest Kit
18:1	1-633710	2	Cushion-Armrest
18:2	3256-22	4	Washer-Flat
18:3	322-10	2	Screw-HH
18:4	105-3623	2	Channel-Armrest
18:5	32153-3	2	Nut-Hex, Side Deform
18:6	105-3621	1	Bracket-Armrest, RH
18:7	105-3622	1	Bracket-Armrest, LH
18:8	321-30	6	Screw-HH
18:9	3296-42	4	Nut-Lock, NI
20	110-0883	1	Retractable Seatbelt Kit
20:2	3212-4	2	Screw-HH
20:3	3296-7	2	Nut-Lock

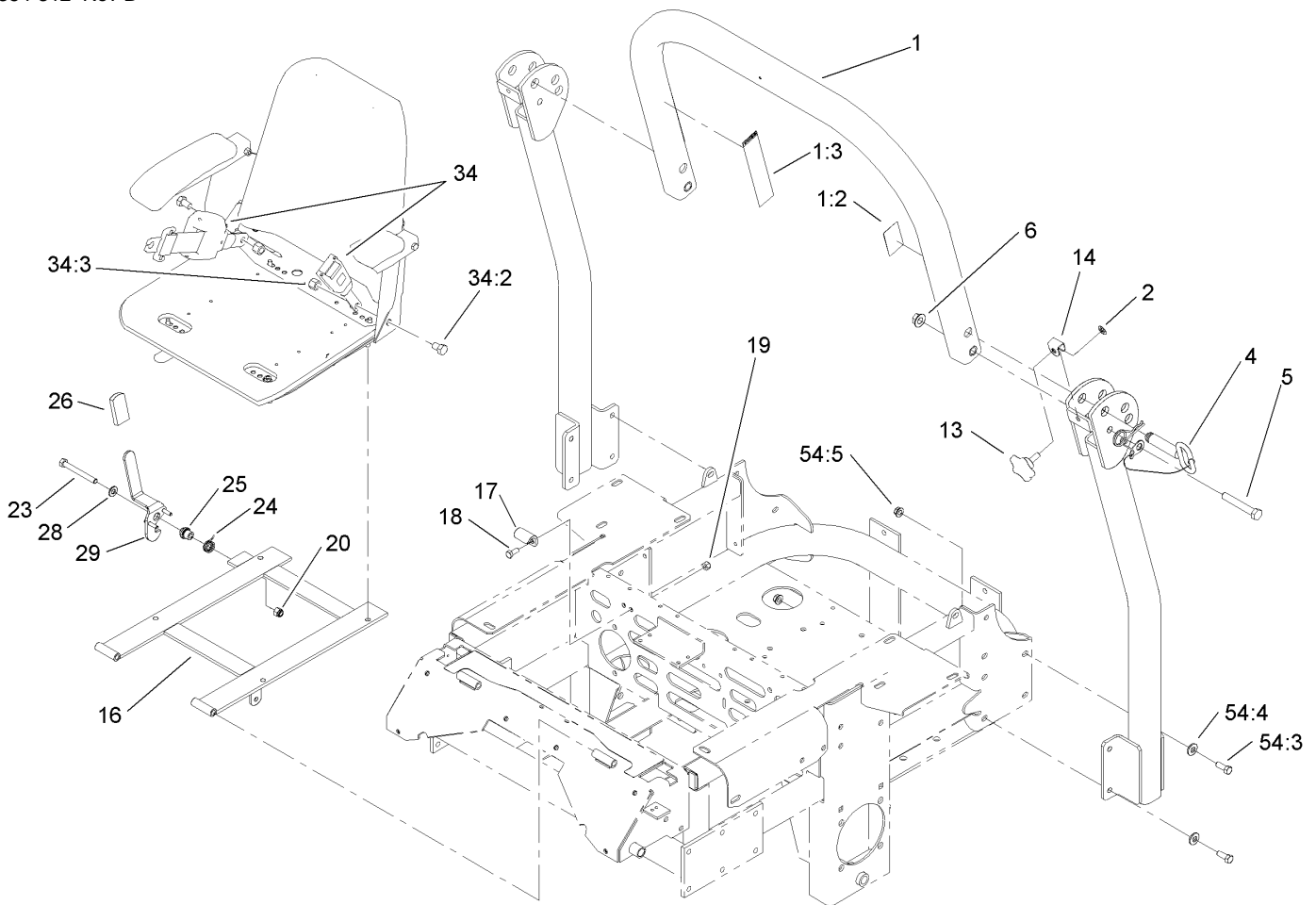



## Roll-Over-Protection-System Assembly No. 108-1097

Ref	Part No.	Qty.	Description
① 1		1	Upper Tube ASM
1:2	107-2101	1	Decal-ROPS
1:3	107-2102	1	Decal-Warning, Folding ROPS
2	107-3154	2	Nut-Push
4	103-4553	2	ROPS Fold Pin ASM
5	325-13	2	Screw-HH
6	32128-23	2	Nut-HF
13	106-0887	2	Knob
14	107-3124	2	Clip
16	107-3052-03	1	Seat Support Frame ASM
17	107-3058	1	Catch-Latch, Seat
18	322-3	2	Screw-HH
19	3296-29	2	Nut-Lock, NI
20	3296-39	1	Nut-Lock, NI
23	323-20	1	Screw-HH
24	107-0076	1	Spring-Torsion
25	107-0075	1	Bushing-Latch, Seat
26	103-4434	1	Grip-Lever
28	3256-24	1	Washer-Flat
29	107-3083	1	Latch ASM
34	110-0883	1	Retractable Seatbelt Kit
34:2	3212-4	2	Screw-HH
34:3	3296-7	2	Nut-Lock
① ② 54		1	Bag-Bolt, ROPS

Ref	Part No.	Qty.	Description
54:3	323-6	8	Screw-HH
54:4	98-5975	8	Washer-Belleville
54:5	3290-357	8	Nut-HHF, Whiz

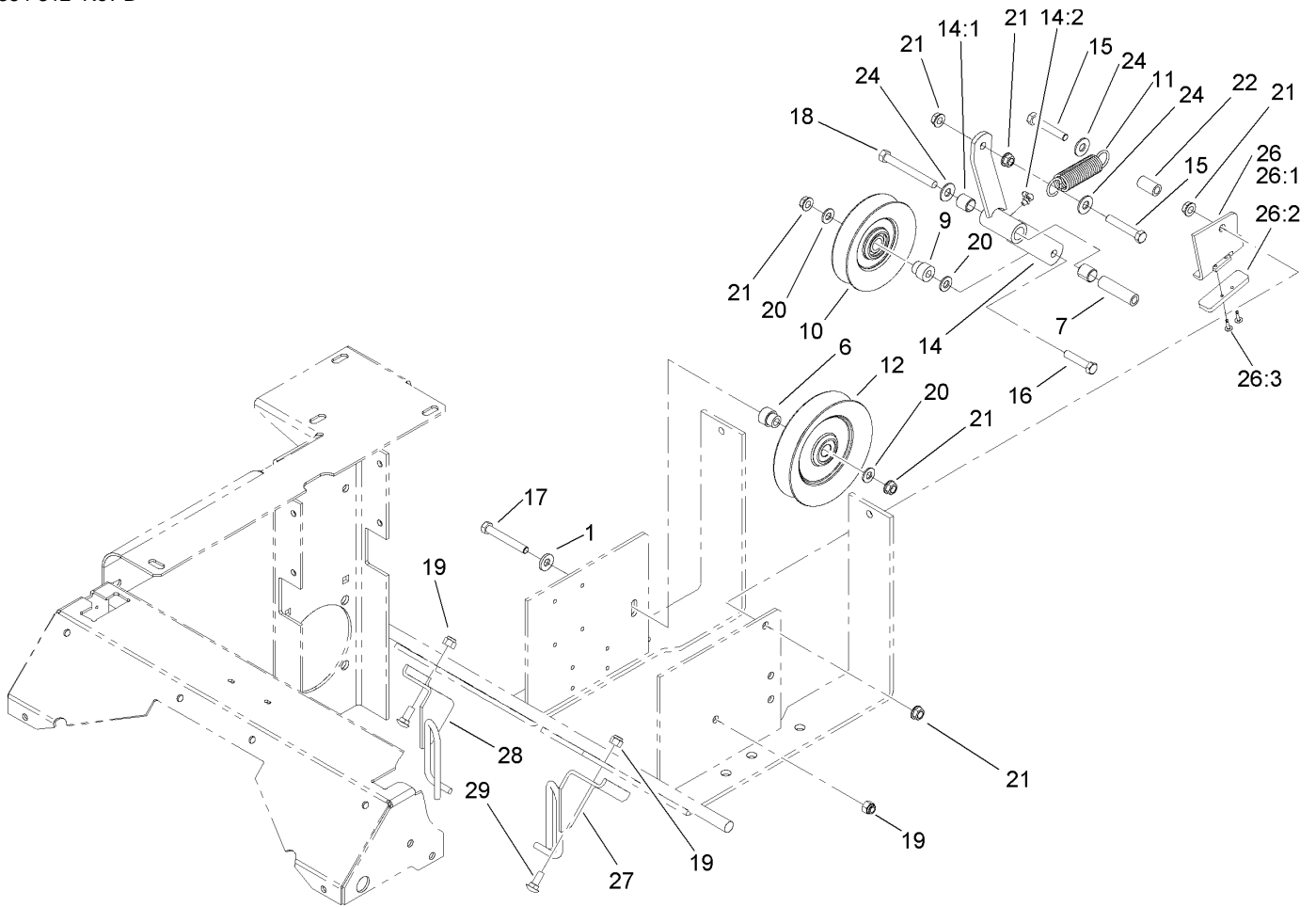



### Drive Idler Assembly

Ref	Part No.	Qty.	Description
1	98-5975	1	Washer-Belleville
6	103-2627	1	Bushing-Idler
7	1-603384	1	Bushing-Pivot, Idler
9	1-603496	1	Bushing-Idler
10	99-4638	1	Idler
11	1-603402	1	Spring-Extension
12	1-633166	1	Pulley-Idler
14	103-3147	1	Arm ASM
14:1	1-513034	2	Sleeve-Bearing
14:2	302-40	1	Fitting-Grease
15	323-12	2	Screw-HH
16	323-9	1	Screw-HH
17	323-13	1	Screw-HH
18	1-800805	1	Screw-HH
19	3296-39	3	Nut-Lock, NI
20	3256-24	3	Washer-Flat
21	3290-357	6	Nut-HHF, Whiz
22	1-603401	1	Spacer-Fender
24	3256-4	3	Washer-Flat
26	106-3271	1	Travel Limiter ASM
26:1	106-3228-03	1	Plate-Limiter, Pulley
26:2	106-3229	1	Pad-Bumper
26:3	3269-24	2	Rivet
27	108-7204-03	1	Guide-Belt, LH

Ref	Part No.	Qty.	Description
28	108-7229-03	1	Guide-Belt, RH
29	3231-2	2	Screw-CARR



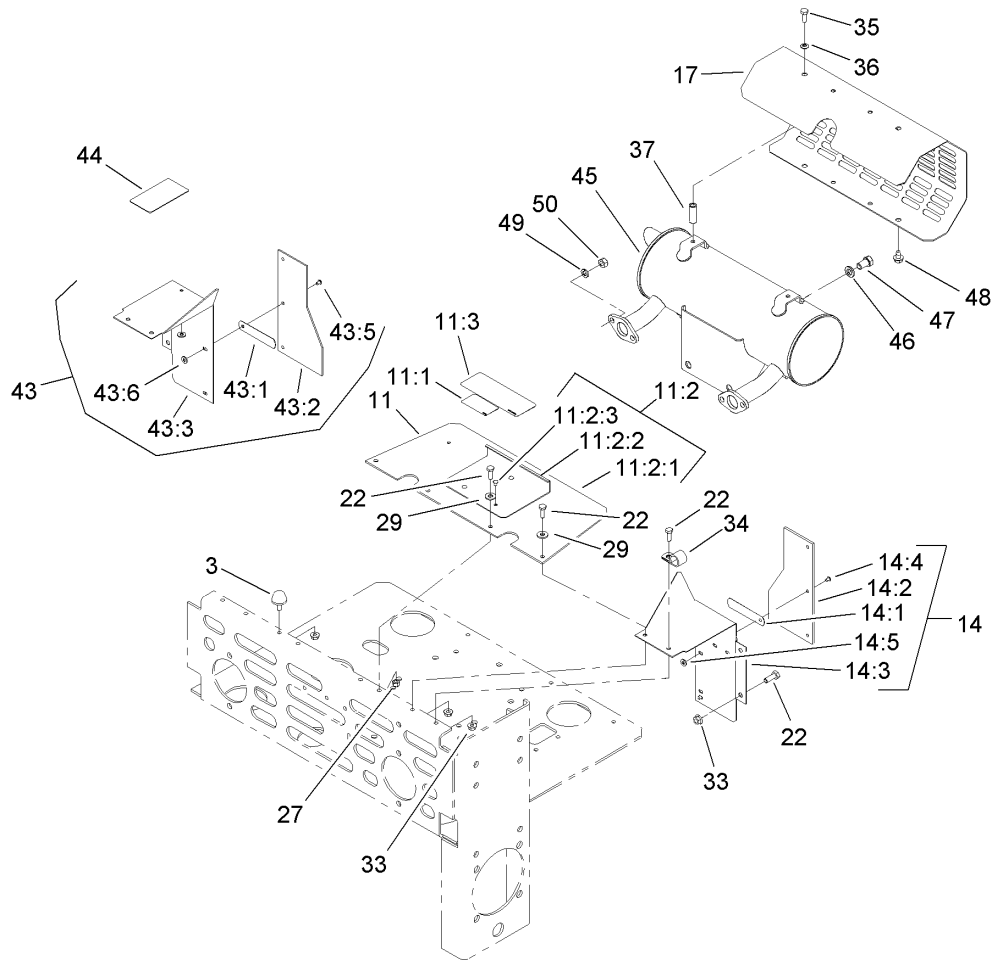

## Muffler and Guard Assembly

Ref	Part No.	Qty.	Description
3	1-523420	2	Bumper
11	105-6196	1	Shield ASM
11:1	1-633462	1	Decal-Important
11:2	103-1301	1	Drive Cover ASM
11:2:1	103-1308	1	Shield-Engine
11:2:2	103-1304-03	1	Plate-Cover, Drive
11:2:3	1-803035	5	Rivet-Pop
11:3	103-5881	1	Decal-Devices, Rotating
14	103-0241	1	LH Extended Shield ASM
14:1	1-523285	2	Clip-Baffle, Rear
14:2	103-0243	1	Shield
14:3	1-633795-03	1	Baffle-Engine Shield, LH
14:4	1-803035	3	Rivet-Pop
14:5	3256-63	3	Washer-Flat
17	1-643313-03	1	Guard-Muffler
22	321-4	10	Screw-HH
27	3296-42	4	Nut-Lock, NI
29	3256-2	4	Washer-Flat
33	32128-33	5	Nut-HF
34	1-633396	1	Clip-Loom
35	1-809108	2	Screw-HWH
36	1-323235	2	Washer-Spring
37	1-323236	2	Spacer
43	103-0242	1	RH Extended Shield ASM

Ref	Part No.	Qty.	Description
43:1	1-523285	2	Clip-Baffle, Rear
43:2	103-0243	1	Shield
43:3	1-633794-03	1	Shield-RH
43:5	1-803035	3	Rivet-Pop
43:6	3256-63	3	Washer-Flat
44	1-643339	1	Decal-Routing, Belt
45	103-2758	1	Muffler
46	3253-6	2	Washer-Lock
47	324-2	2	Screw-HH
48	9266934	2	Screw
49	1-805005	4	Washer-Lock
50	33014-00	4	Nut-Hex

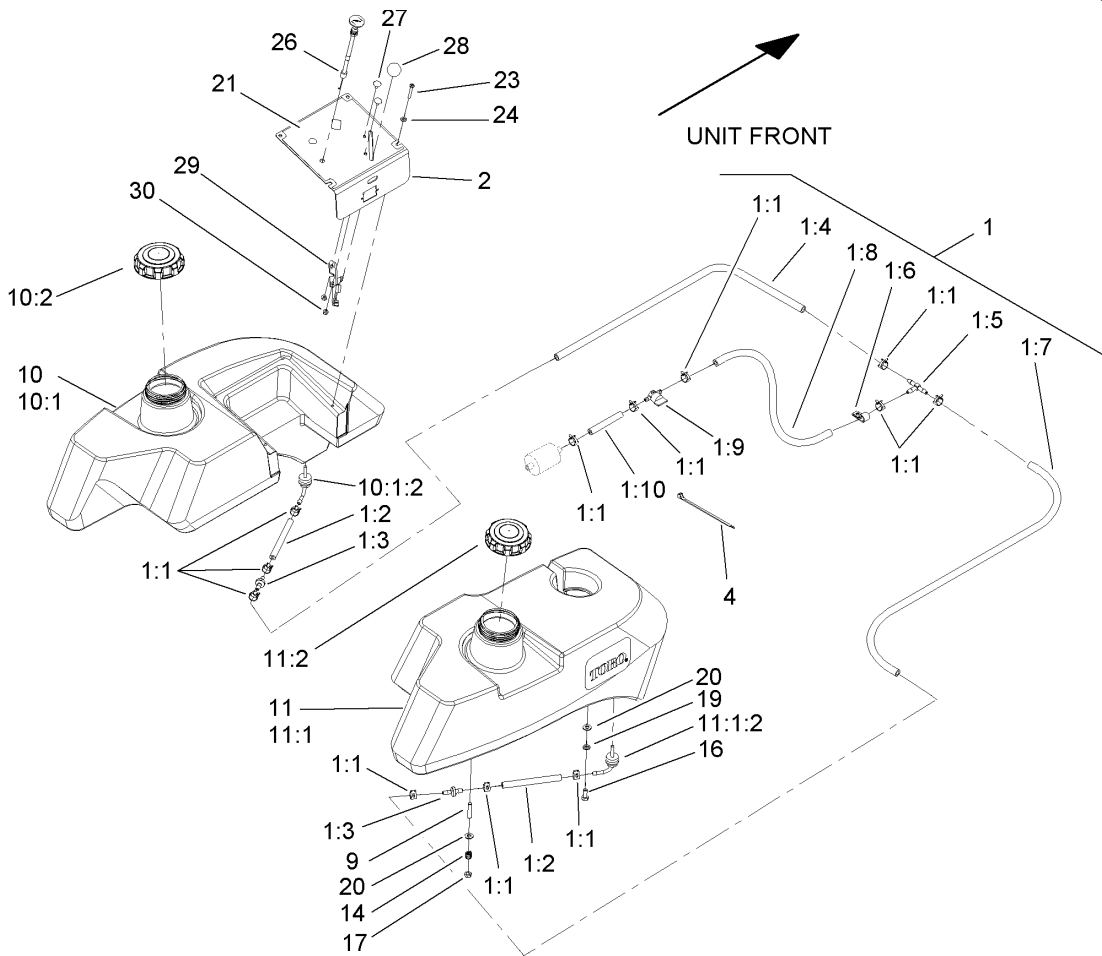

## Fuel Tank Assembly

Ref	Part No.	Qty.	Description
1	107-9285	1	Fuel Line ASM
1:1	1-303077	12	Clamp
1:2	109-0678	2	Hose-Fuel
1:3	99-5000	2	Valve-Check, Fuel
1:4	109-0305	1	Hose-Fuel
1:5	99-5005	1	Fitting-Tee, Barbed
1:6	1-513762	1	Clip-Loom
1:7	109-0302	1	Hose-Fuel
1:8	110-5702	1	Hose-Fuel
1:9	1-603770	1	Valve-Fuel
1:10	109-0660	1	Hose-Fuel
2	107-8079-03	1	Panel-Control
4	1-303335	4	Tie-Plastic
9	1-633023	6	Stud
10	105-3644	1	LH Fuel Tank Kit ASM
② 10:1		1	LH Fuel Tank ASM
10:1:2	103-2605	1	Fitting-Fuel, Bulkhead
10:2	109-0346	1	Cap-Fuel, Gas
11	105-3643	1	RH Fuel Tank Kit ASM
② 11:1		1	RH Fuel Tank ASM
11:1:2	103-2605	1	Fitting-Fuel, Bulkhead
11:2	109-0346	1	Cap-Fuel, Gas
14	1-633349	6	Spring-Tank, Fuel
16	322-3	2	Screw-HH

Ref	Part No.	Qty.	Description
17	3296-47	6	Nut-Lock, NI
19	1-805005	2	Washer-Lock
20	3256-23	8	Washer-Flat
21	106-9969	1	Decal-Panel, Control
23	3251-1	4	Screw-PPH
24	1-303435	4	Washer-Spring
26	106-9962	1	Control-Choke, Push / Pull
27	1-807513	2	Bolt-CARR
28	1-513592	1	Knob-Ball
29	107-8073	1	Cable-Throttle
30	3296-2	2	Nut-Lock

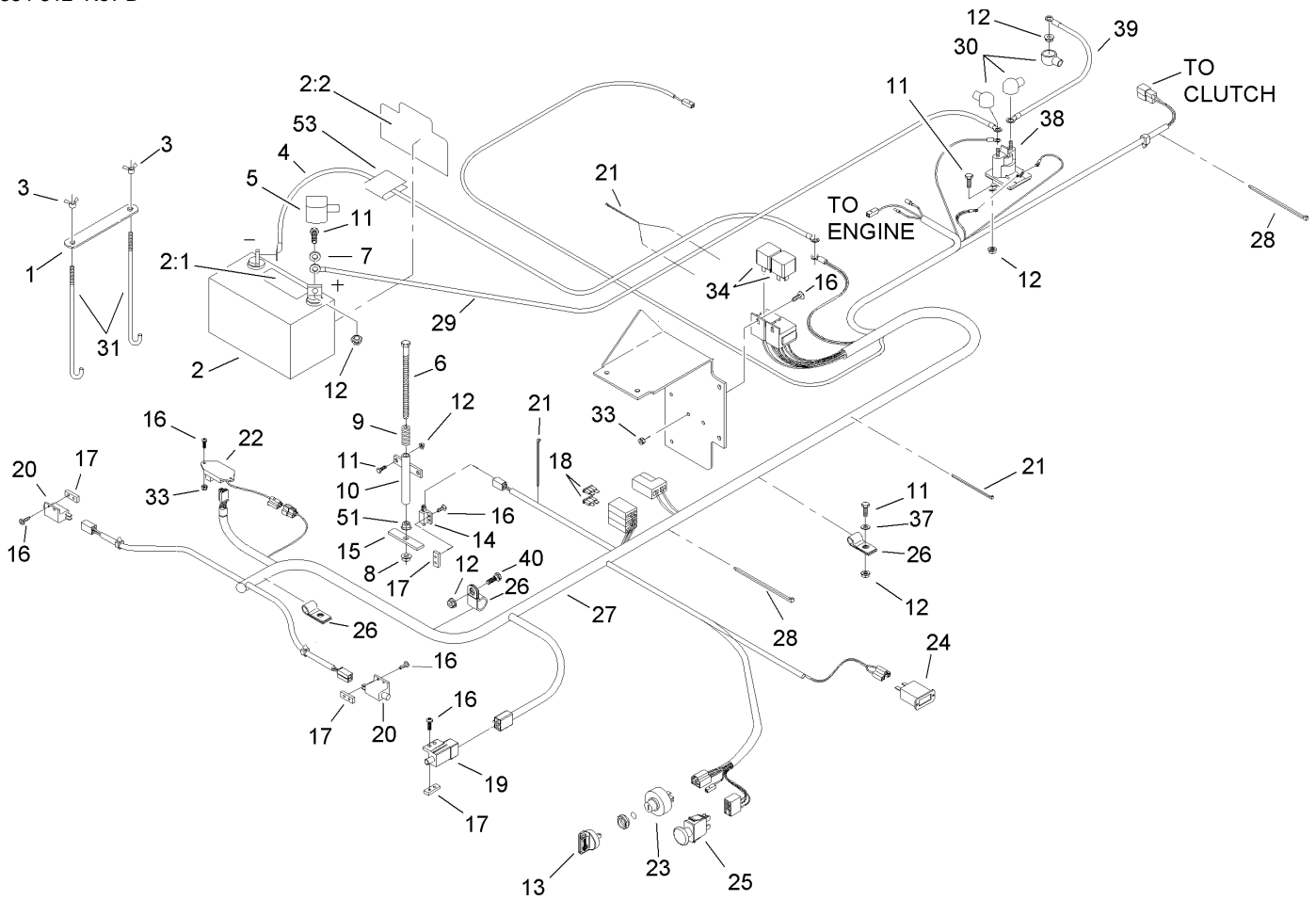

## Electrical Assembly

Ref	Part No.	Qty.	Description
1	107-9277-03	1	Strap-Holddown, Battery
2	105-1692	1	Battery
2:1	104-4163	1	Decal-Battery
2:2	104-4164	1	Decal-Battery
3	1-543792	2	Wingnut
4	1-633307	1	Wire-Ground
5	1-543391	1	Insulator-Battery
6	1-800282	1	Screw-HH
7	3256-2	2	Washer-Flat
8	3296-29	1	Nut-Lock, NI
9	1-523415	1	Spring-Switch, Seat
10	1-522424-03	1	Mount-Spring, Seat
11	321-4	6	Screw-HH
12	32128-33	6	Nut-HF
13	63-8360	2	Key-Ignition
14	1-513152	1	Switch-Closed, Normally
15	1-513180	1	Plate-Switch, Seat
16	3290-500	12	Screw-PPH
17	1-633181	4	Plate-Tapped
18	1-816001	2	Fuse-Blade Type, 20 Amp
19	1-633111	1	Switch
20	1-513051	2	Switch-Open, Normally
21	1-303287	5	Tie-Plastic
22	100-6186	1	Module-Delay, Seat

Ref	Part No.	Qty.	Description
23	103-0206	1	Switch-Starting, Key
24	1-513374	1	Meter-Hour
25	103-5221	1	Switch-PTO
26	1-633396	3	Clip-Loom
27	106-7494	1	Harness-Wire
28	1-303335	2	Tie-Plastic
29	1-523281	1	Wire-Starter
30	1-543393	1	Insulator-Solenoid
31	1-633651	2	Bolt-Holddown
33	3296-2	4	Nut-Lock
34	1-643275	2	Relay
37	3256-22	1	Washer-Flat
38	1-513075	1	Switch-Solenoid
39	1-633306	1	Wire-Starter
40	321-2	1	Screw-HH
51	3217-6	1	Nut-Hex
53	107-9309	1	Decal-Instructions, Charging

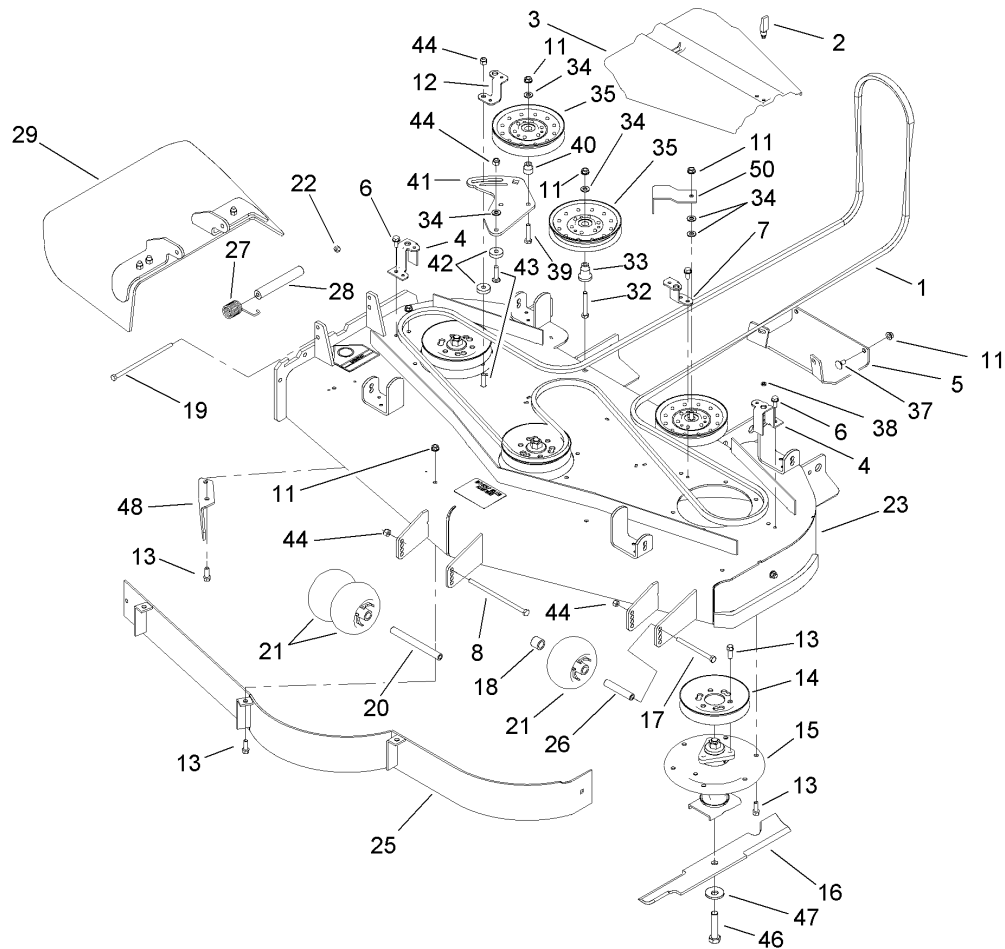

## 52 Inch Deck Assembly

Ref	Part No.	Qty.	Description
1	105-7790	1	Belt
2	74-5950	2	Latch-Swell
3	107-8536	2	Cover-Belt
4	108-4121-01	2	Bracket-Cover
5	106-7358-01	1	Plate-Skid
6	32144-70	3	Screw-HH
7	108-2177-01	1	Bracket-Cover, Tall
8	323-28	1	Screw-HH
11	3290-357	37	Nut-HHF, Whiz
12	108-2178-01	1	Bracket-Cover, Short
13	92-1624	32	Screw
14	107-1683	3	Pulley
15	107-8504	3	Spindle ASM
16	105-7781-03	3	Blade-Hi Flow
17	323-23	1	Screw-HH
18	98-7913	1	Tube-Spacer
19	322-50	1	Screw-HH
20	98-5967	1	Spacer-Wheel
21	1-603299	3	Roller-Scalp, Anti
22	3296-29	1	Nut-Lock, NI
23	110-5551	1	Deck ASM
25	108-2185-01	1	Baffle ASM
26	98-7912	1	Tube-Spanner
27	108-4052	1	Spring-Torsion

Ref	Part No.	Qty.	Description
28	105-4622	1	Spacer
29	108-7770	1	Rubber Deflector ASM
32	323-12	2	Screw-HH
33	106-3214	2	Mount-Pulley
34	3256-24	5	Washer-Flat
35	1-633109	3	Idler-Flat
37	3231-1	11	Screw-CARR
38	99-3058	2	Washer
39	323-9	1	Screw-HH
40	1-603496	1	Bushing-Idler
41	107-8516-01	1	Plate-Idler
42	105-7788	2	Spacer
43	3231-4	2	Screw-CARR
44	3296-39	4	Nut-Lock, NI
46	103-0862	3	Screw-Cap
47	103-0865	3	Washer-Blade Bolt, Heavy
48	106-3216-01	1	Baffle-Discharge
50	108-7220-01	1	Guide-Belt

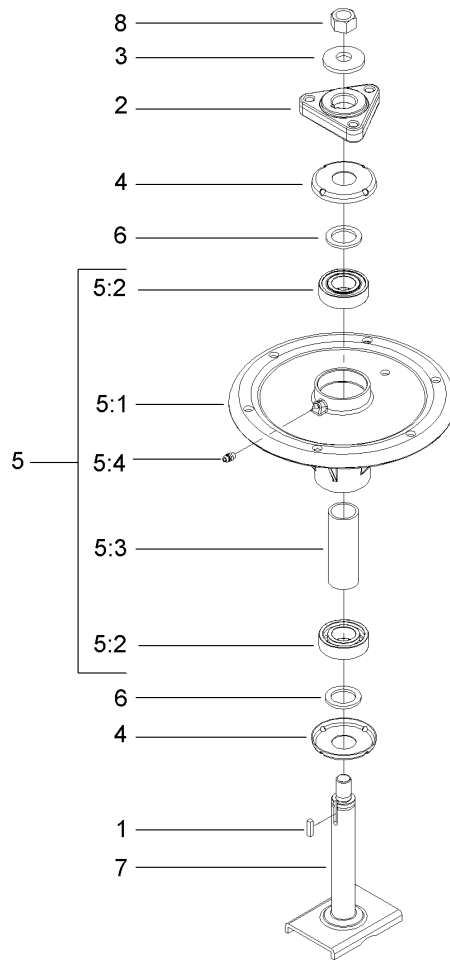

## Spindle Assembly No. 107-8504

Ref	Part No.	Qty.	Description
1	10-8040	1	Key-Square
2	106-3277	1	Hub-Pulley
3	103-0865	1	Washer-Blade Bolt, Heavy
4	106-3204	2	Shield-Bearing
5		1	Spindle Bearing ASM
5:1	106-3211	1	Housing-Spindle
5:2	113514	2	Bearing-Ball
5:3	107-8502	1	Spacer-Bearing
5:4	302-5	1	Fitting-Grease
6	3-8514	2	Washer-Thrust
7	107-8501	1	Spindle ASM
8	3219-6	1	Nut-Hex

--	--	--	--





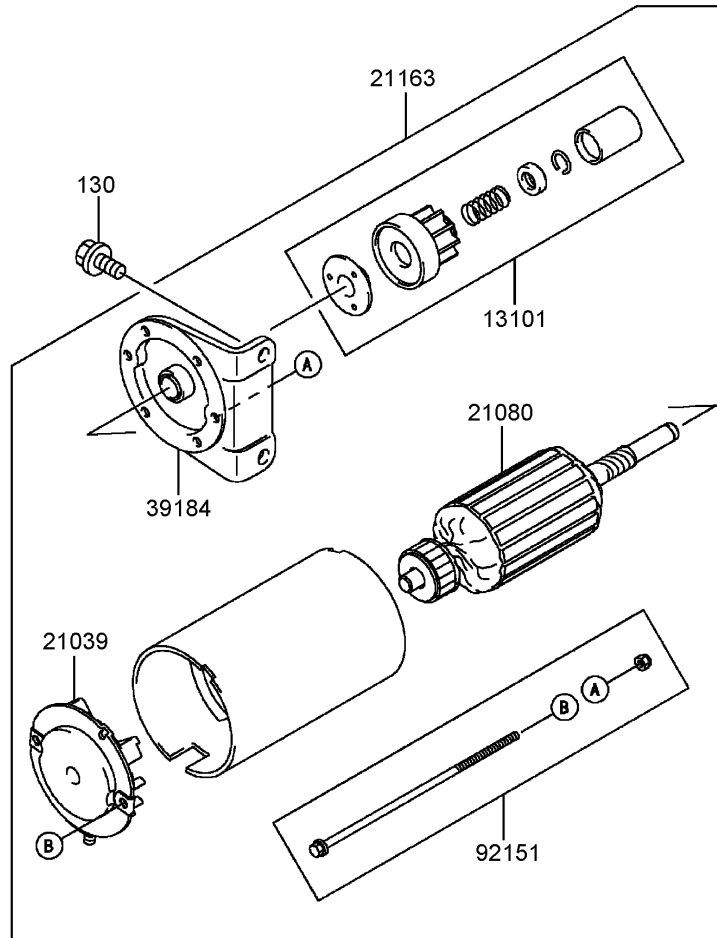

## Starter Assembly Kawasaki FH721D-CS05-R

Ref	Part No.	Qty.	Description
● 13101	13101-7003	1	Gear ASM
● 21039	21039-7004	1	Brush
● 21080	21080-7001	1	Armature
● 21163	21163-7010	1	Starter-Electric
● 39184	39184-7004	1	Bracket ASM
● 92151	92151-7013	1	Bolt
● 130	130B0816	2	Bolt-Flanged

# Cylinder and Crankcase Assembly Kawasaki FH721D-CS05-R

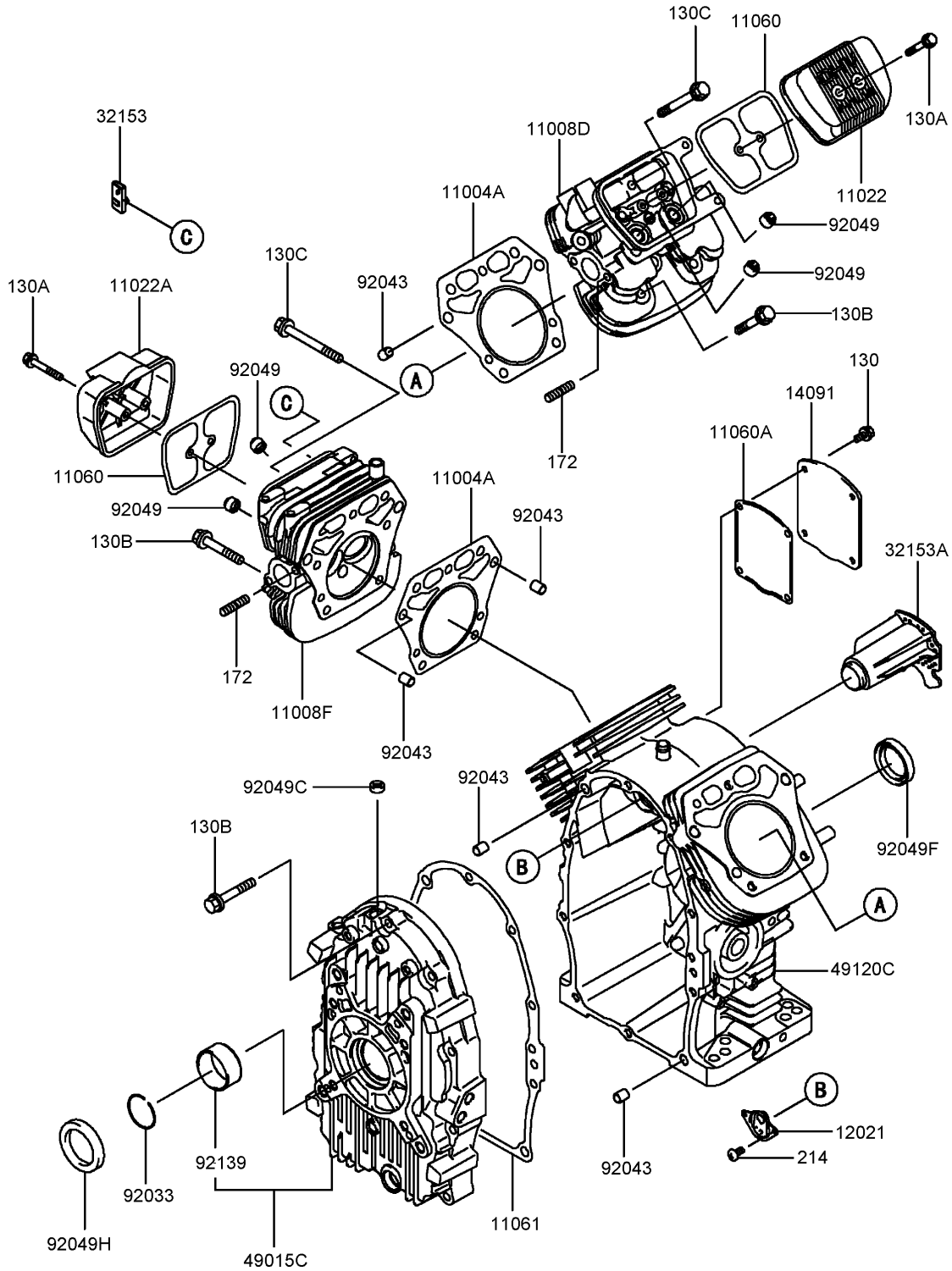

## Cylinder and Crankcase Assembly Kawasaki FH721D-CS05-R

Ref	Part No.	Qty.	Description				
③11004A	11004-7006	2	Gasket-Head				
③11008D	11008-7023	1	Head-Cylinder, No.2				
③11008F	11008-7024	1	Head-Cylinder, No.1				
③11022	11022-7002	1	Case-Rocker				
③11022A	11022-7004	1	Case-Rocker				
③11060	11060-7013	2	Gasket-Case, Rocker				
③11060A	11060-7014	1	Gasket-Breather				
③11061	11061-7047	1	Gasket-Crankcase				
③12021	12021-7002	1	Reed Valve ASM				
③14091	14091-7004	1	Cover				
③32153	32153-7003	1	Pipe				
③32153A	32153-7004	1	Pipe				
③49015C	49015-6269	1	Cover-Crankcase				
③49120C	49120-6163	1	Crankcase				
③92033	92033-7004	1	Ring-Snap				
③92043	92043-7001	6	Pin				
③92049	92049-7001	4	Seal-Oil, Rvc2 (6X11X10.2)				
③92049C	92049-7005	1	Seal-Oil, So (8X14X5 Hs)				
③92049F	92049-7010	1	Seal-Oil, Sd (35X48X8 R Hs)				
③92049H	92049-7022	1	Seal-Oil, Sd-40-55-8-L-Hs				
③92139	92139-7009	1	Bushing				
③130	130B0612	4	Bolt-Flanged				
③130A	130B0640	4	Bolt-Flanged				
③130B	130T0850	18	Bolt-Flanged				
③130c	130T0875	2	Bolt-Flanged				
③172	172G0818	4	Bolt-Stud				
③214	214B0408	2	Screw-Pan				

# Piston and Crankshaft Assembly Kawasaki FH721D-CS05-R

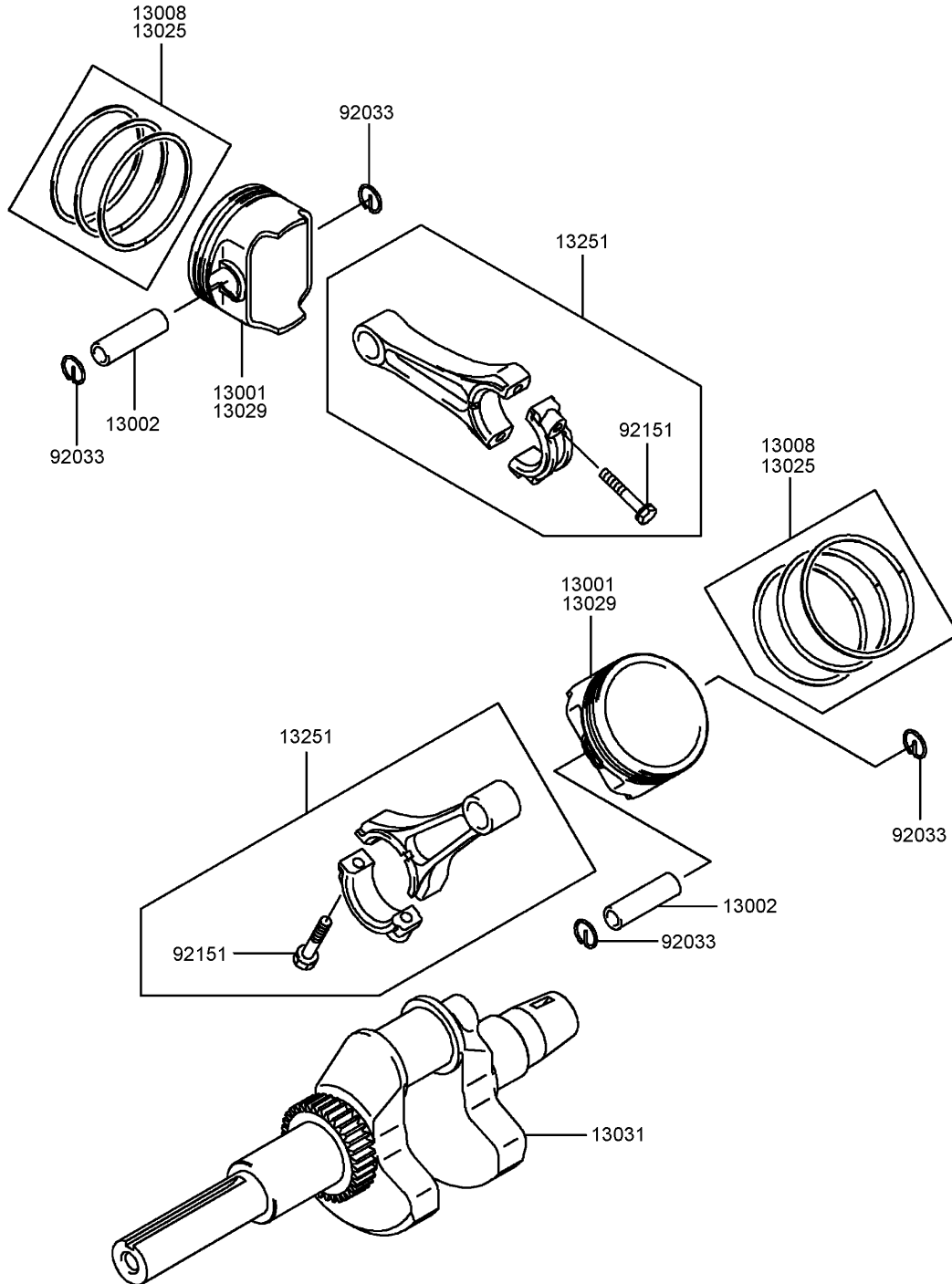

# Piston and Crankshaft Assembly

## Kawasaki FH721D-CS05-R

Ref	Part No.	Qty.	Description				
③ 13001	13001-7007	2	Piston-Engine				
③ 13002	13002-7001	2	Pin-Piston				
③ 13008	13008-6058	2	Ring Set-Piston				
③ 13025	13025-7002	1	Ring-Set, Piston (L,0.50)				
③ 13029	13029-7003	1	Piston-Engine (L,0.50)				
③ 13031	13031-7007	1	Crankshaft				
③ 13251	13251-7005	2	Connecting Rod ASM				
③ 92033	92033-7005	4	Ring-Snap				
③ 92151	92151-7017	4	Bolt (6X35)				

# Valve and Camshaft Assembly Kawasaki FH721D-CS05-R

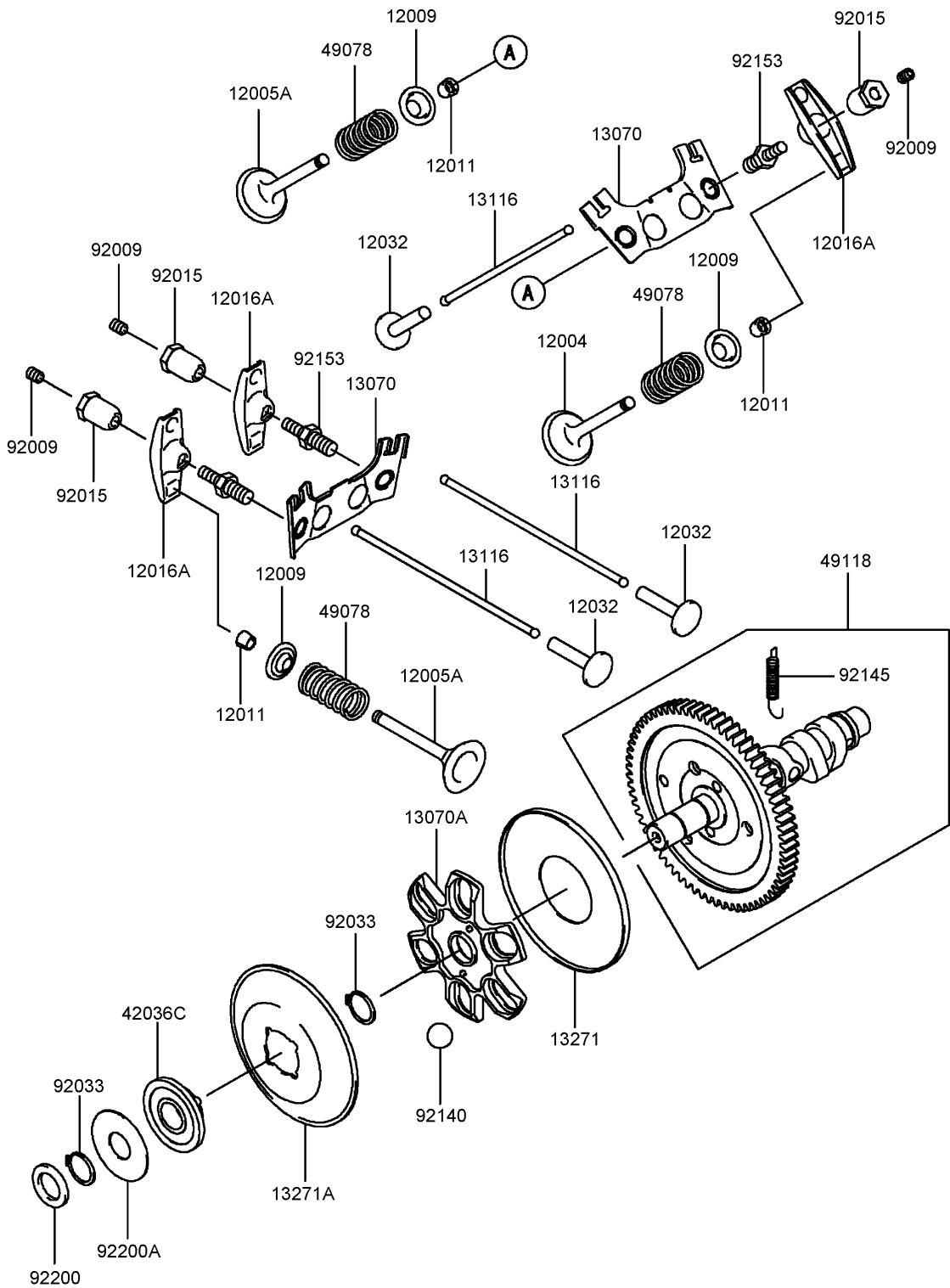

## Valve and Camshaft Assembly Kawasaki FH721D-CS05-R

Ref	Part No.	Qty.	Description				
⑤ 12004	12004-7002	2	Valve-Intake				
⑤ 12005A	12005-7004	2	Valve-Exhaust				
⑤ 12009	12009-7001	4	Retainer-Spring, Valve				
⑤ 12011	12011-2056	8	Collet				
⑤ 12016A	12016-7007	4	Arm-Rocker				
⑤ 12032	12032-7001	4	Tappet				
⑤ 13070	13070-7007	2	Guide				
⑤ 13070A	13070-7008	1	Arm-Rocker				
⑤ 13116	13116-7002	4	Rod-Push				
⑤ 13271	13271-7007	1	Plate				
⑤ 13271A	13271-7021	1	Plate-Governor				
⑤ 42036C	42036-7010	1	Sleeve				
⑤ 49078	49078-7002	4	Spring-Valve, Engine				
⑤ 49118	49118-7007	1	Camshaft				
⑤ 92009	92009-2341	4	Screw				
⑤ 92015	92015-2253	4	Nut				
⑤ 92033	92033-7001	2	Ring-Snap				
⑤ 92140	92140-7002	6	Ball				
⑤ 92145	92145-7001	1	Spring				
⑤ 92153	92153-7019	4	Bolt				
⑤ 92200	92200-7001	1	Washer				
⑤ 92200A	92200-7009	1	Washer				

# Lubrication Equipment Assembly Kawasaki FH721D-CS05-R

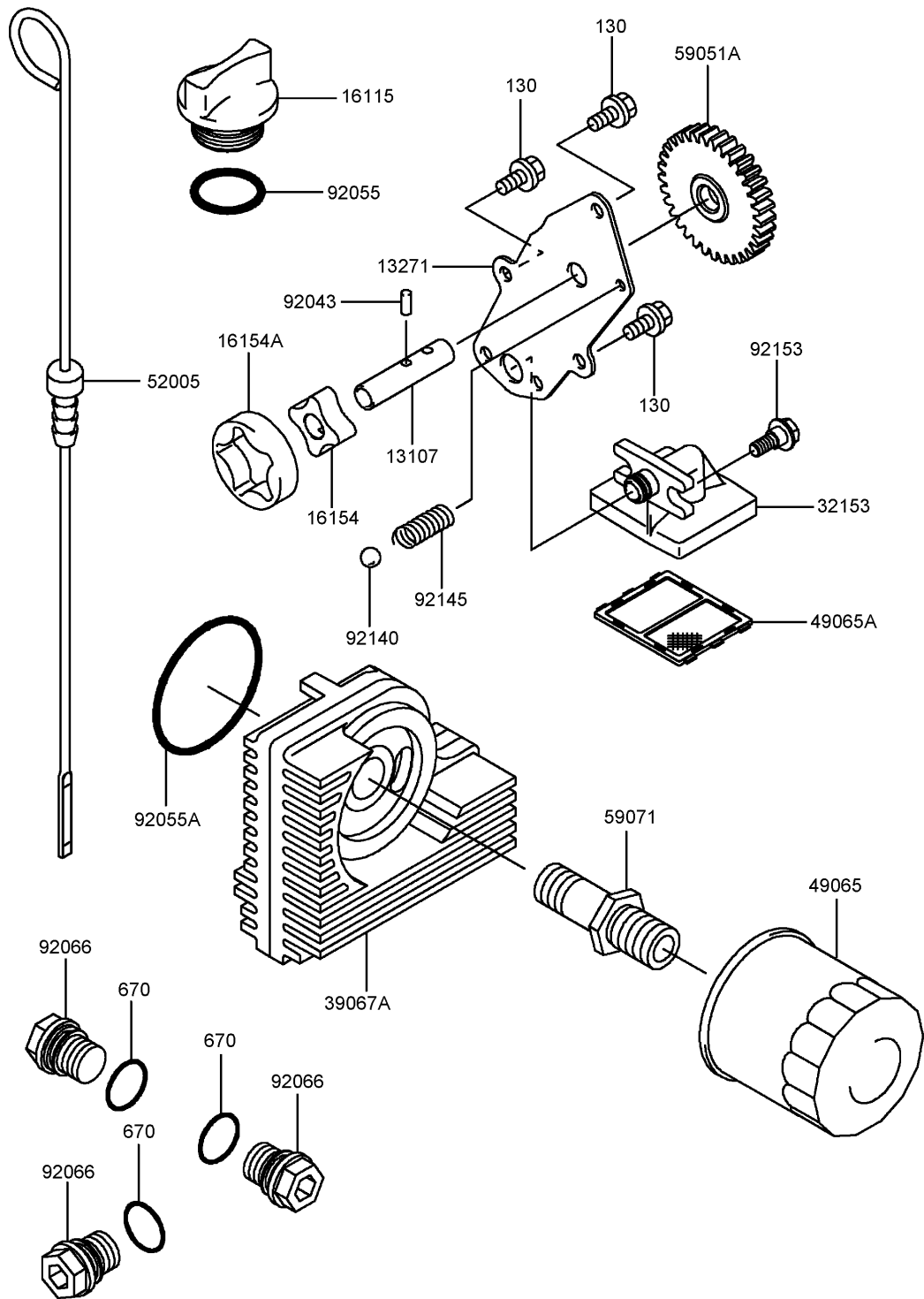

## Lubrication Equipment Assembly Kawasaki FH721D-CS05-R

Ref	Part No.	Qty.	Description				
③13107	13107-7009	1	Shaft				
③13271	13271-7014	1	Plate				
③16115	16115-7001	1	Cap-Filter, Oil				
③16154	16154-2053	1	Rotor-Pump (In)				
③16154A	16154-2054	1	Rotor-Pump (Out)				
③32153	32153-7002	1	Pipe				
③39067A	39067-7002	1	Cooler-Oil				
③49065	49065-2078	1	Filter-Oil				
③49065A	49065-7005	1	Filter-Oil				
③52005	52005-7003	1	Guage				
③59051A	59051-7011	1	Gear-Spur				
③59071	59071-7009	1	Joint				
③92043	92043-7003	2	Pin				
③92055	92055-7004	1	O-Ring				
③92055A	92055-7006	1	O-Ring				
③92066	92066-7003	3	Plug				
③92140	92140-7003	1	Ball				
③92145	92145-7002	1	Spring				
③92153	92153-7007	2	Bolt				
③130	130B0612	3	Bolt-Flanged				
③670	670D2016	3	O-Ring (16Mm)				

# Cooling Equipment Assembly Kawasaki FH721D-CS05-R

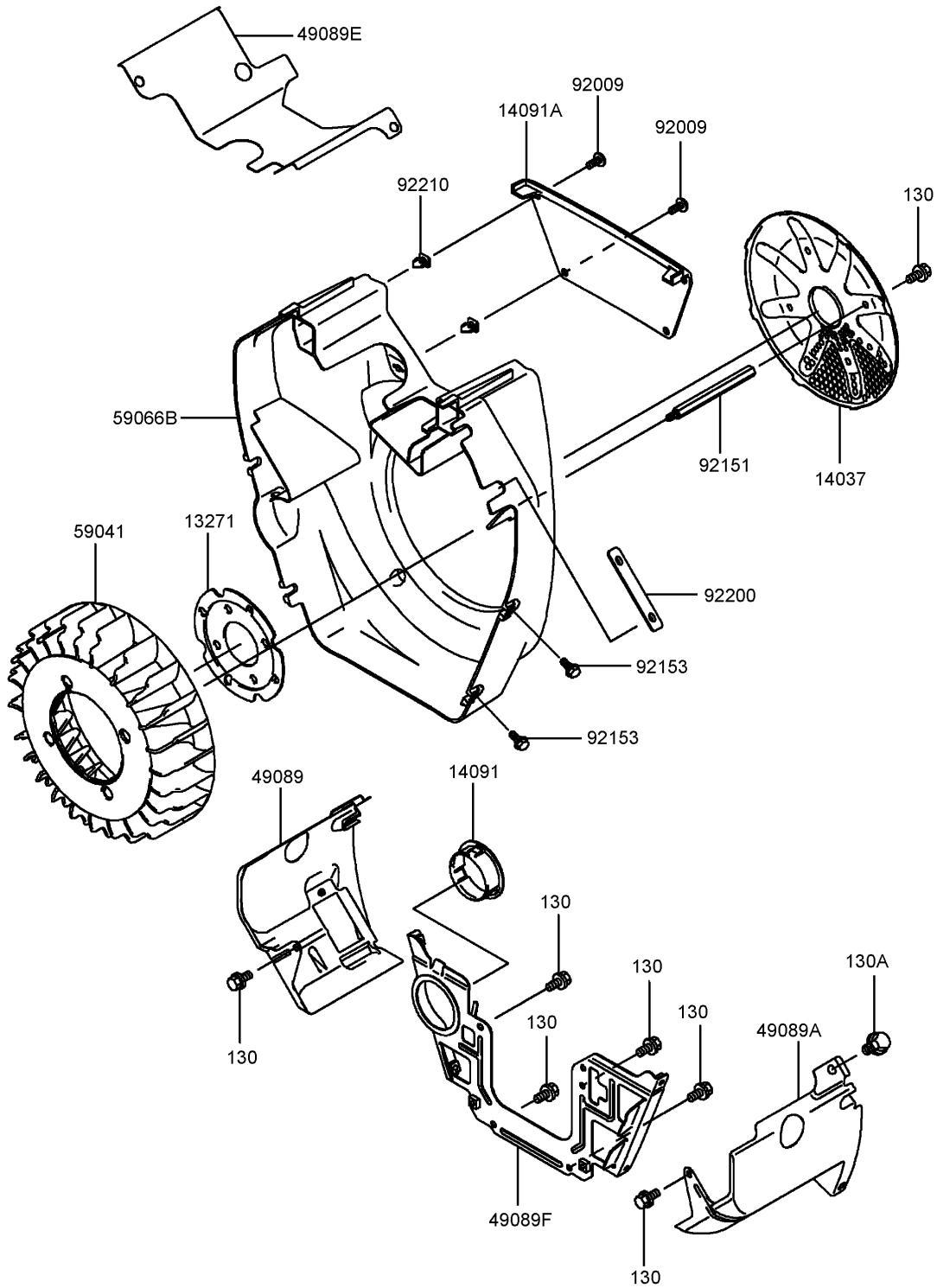

## Cooling Equipment Assembly Kawasaki FH721D-CS05-R

Ref	Part No.	Qty.	Description				
③13271	13271-7015	1	Plate				
③14037	14037-7014	1	Screen				
③14091	14091-7002	1	Cover				
③14091A	14091-7005	1	Cover				
③49089	49089-7004	1	Shroud-Engine				
③49089A	49089-7005	1	Shroud-Engine				
③49089E	49089-7050	1	Shroud-Engine				
③49089F	49089-7056	1	Shroud-Engine				
③59041	59041-7004	1	Fan				
③59066B	59066-7033	1	Housing-Fan				
③92009	92009-7009	4	Screw				
③92151	92151-7018	4	Bolt				
③92153	92153-7007	4	Bolt				
③92200	92200-7011	1	Washer				
③92210	92210-7011	4	Nut				
③130	130B0612	10	Bolt-Flanged				
③130A	130B0816	2	Bolt-Flanged				

# Electric Equipment Assembly Kawasaki FH721D-CS05-R

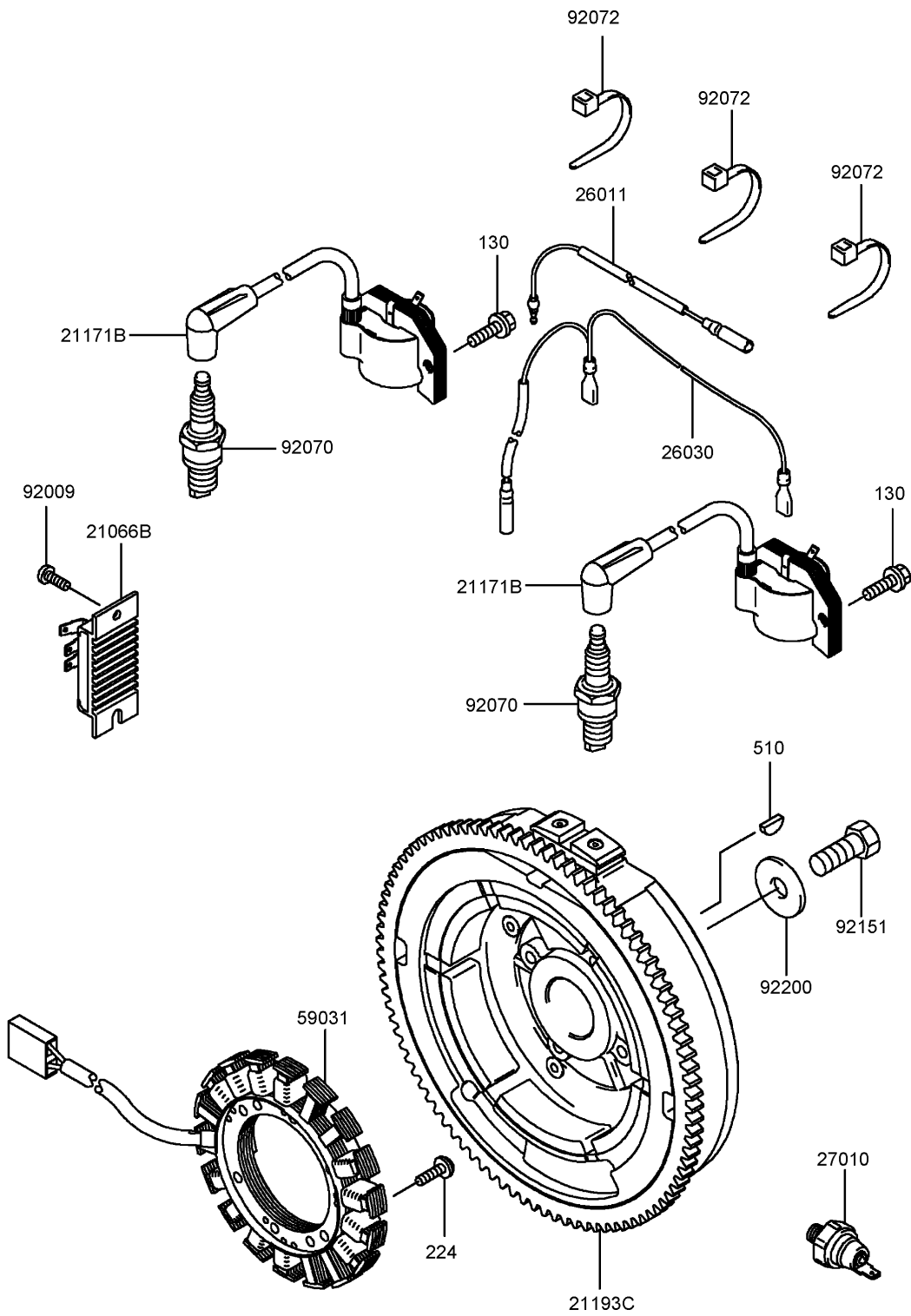

## Electric Equipment Assembly Kawasaki FH721D-CS05-R

Ref	Part No.	Qty.	Description				
③21066B	21066-7011	1	Regulator-Voltage				
③21171B	21171-7013	2	Ignition Coil ASM				
③21193C	21193-7030	1	Flywheel ASM				
③26011	26011-7008	1	Wire-Lead				
③26030	26030-7002	1	Harness				
③27010	27010-7001	1	Switch				
③59031	59031-7009	1	Coil-Charging				
③92009	92009-2308	1	Screw				
③92070	92070-7004	2	Plug-Spark,Bpr4Es(Ngk), Solid				
③92072	92072-7003	3	Band				
③92151	92151-2097	1	Bolt (12X30)				
③92200	92200-7002	1	Washer				
③130	130B0620	4	Bolt-Flanged				
③224	224B0520	4	Screw-Pan				
③510	510A5100	1	Key-Woodruff				

# Control Equipment Assembly Kawasaki FH721D-CS05-R

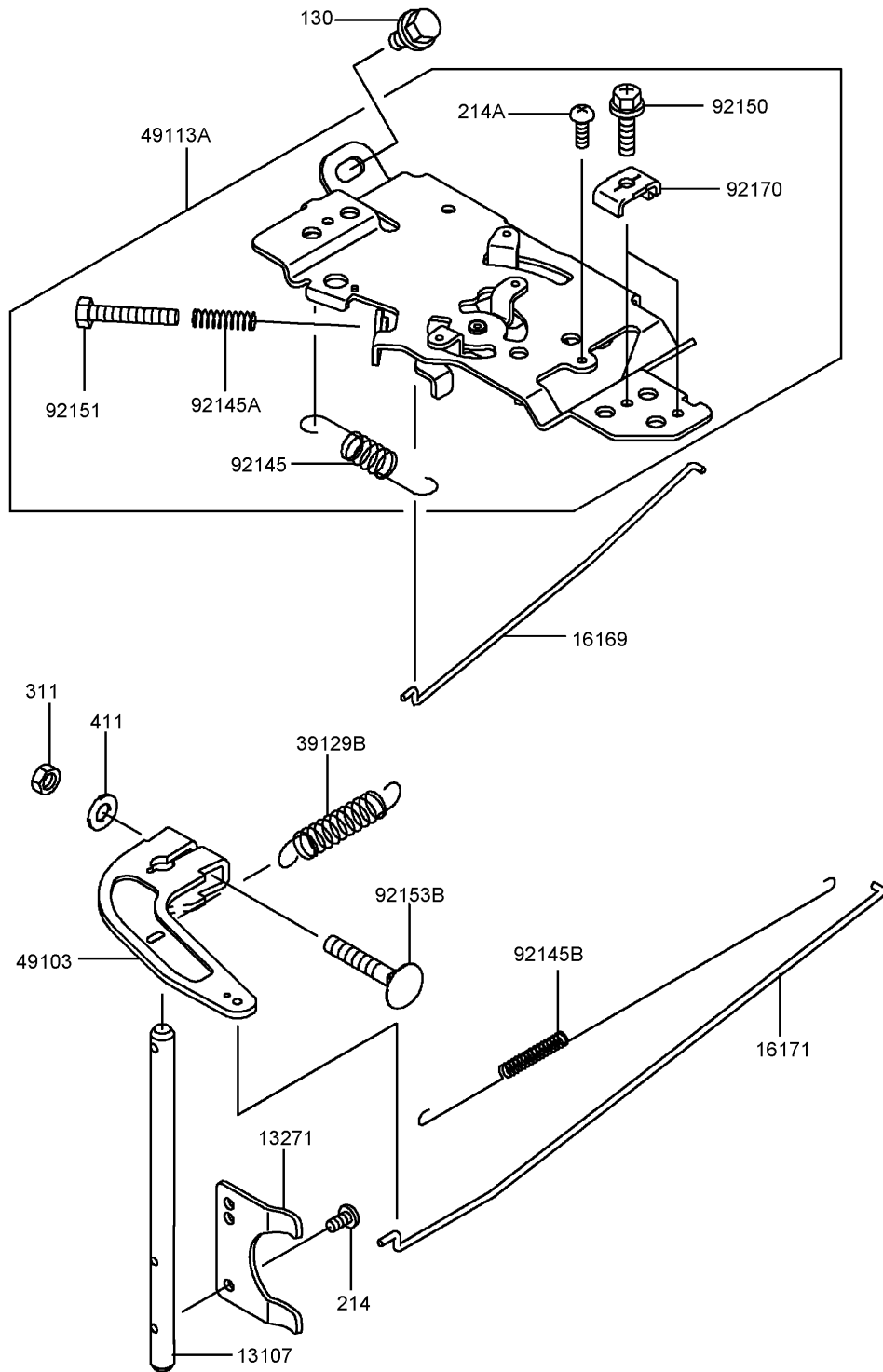

## Control Equipment Assembly Kawasaki FH721D-CS05-R

Ref	Part No.	Qty.	Description				
③13107	13107-7011	1	Shaft				
③13271	13271-7018	1	Plate				
③16169	16169-7008	1	Link-Choke				
③16171	16171-7005	1	Link				
③39129B	39129-7012	1	Spring-Governor				
③49103	49103-7004	1	Arm-Governor				
③49113A	49113-7023	1	Panel-Control				
③92145	92145-7004	1	Spring				
③92145A	92145-7005	1	Spring				
③92145B	92145-7014	1	Spring				
③92150	92150-2182	2	Bolt (5X18)				
③92151	92151-7014	1	Bolt (5X30)				
③92153B	92153-7033	1	Bolt (6X35)				
③92170	92170-7001	2	Clamp				
③130	130B0612	2	Bolt-Flanged				
③214	214B0408	2	Screw-Pan				
③214A	214B0412	1	Screw-Pan				
③311	311B0600	1	Nut-Hex				
③411	411b0600	1	Washer-Plain				

# Carburetor Assembly Kawasaki FH721D-CS05-R

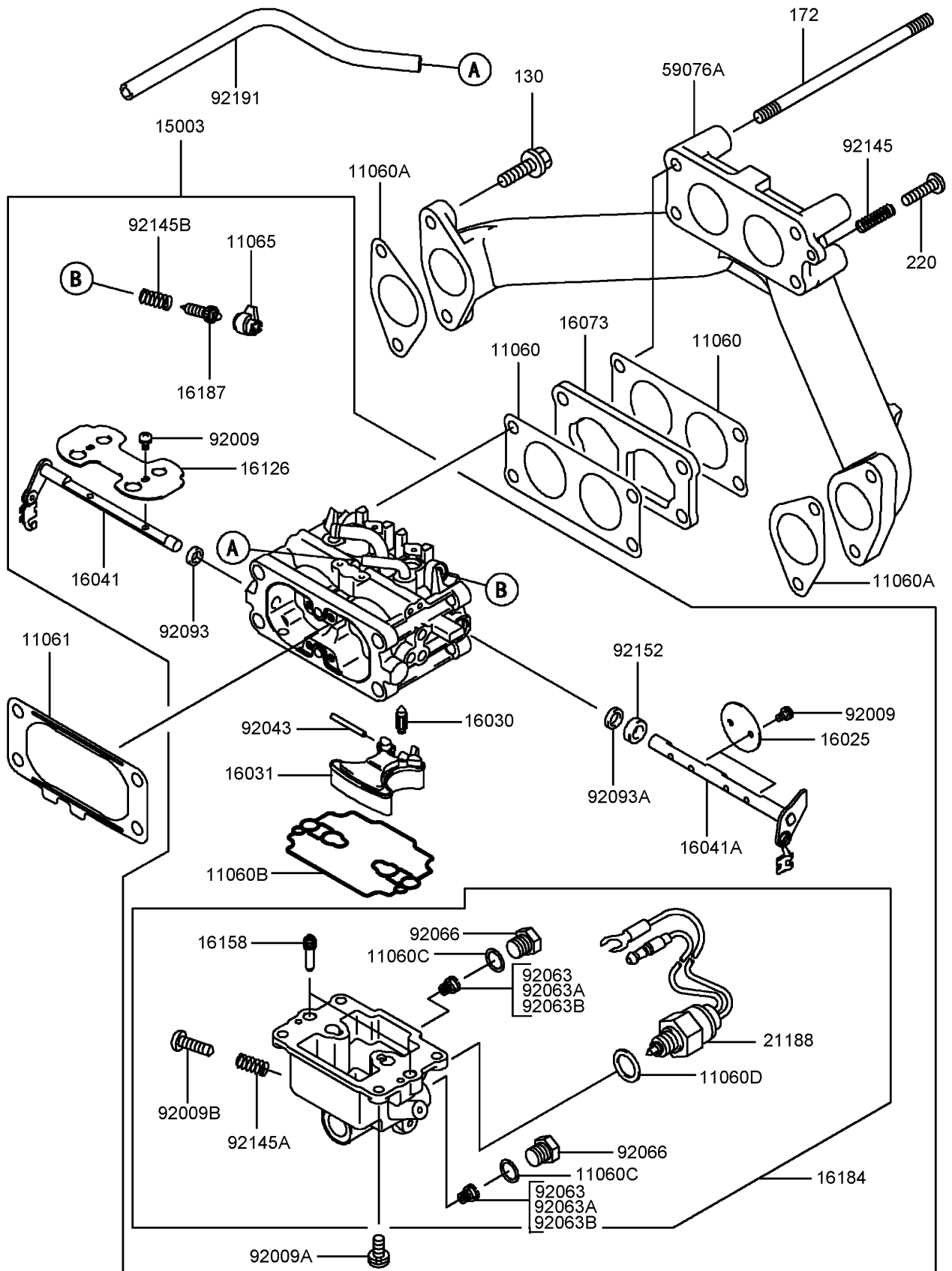

## Carburetor Assembly Kawasaki FH721D-CS05-R

Ref	Part No.	Qty.	Description				
③ 11060	11060-7010	2	Gasket-Carburetor				
③ 11060A	11060-7011	2	Gasket				
③ 11060B	11060-7018	1	Gasket-Chamber, Float				
③ 11060C	11060-7019	2	Gasket-Plug, Main				
③ 11060D	11060-7020	1	Gasket-Solenoid				
③ 11061	11061-7042	1	Gasket-Filter, Air				
③ 11065	11065-7004	2	Cap-Limiter				
③ 15003	15003-7042	1	Carburetor ASM				
③ 16025	16025-7002	2	Valve-Throttle				
③ 16030	16030-7002	1	Valve-Float				
③ 16031	16031-7001	1	Float				
③ 16041	16041-7011	1	Shaft-Carburetor				
③ 16041A	16041-7012	1	Shaft-Carburetor				
③ 16073	16073-7003	1	Insulator				
③ 16126	16126-7004	1	Valve-Choke				
③ 16158	16158-7003	2	Jet-Slow, No.56				
③ 16184	16184-7005	1	Float Chamber ASM				
③ 16187	16187-7003	2	Needle-Jet				
③ 21188	21188-7001	1	Solenoid				
③ 59076A	59076-7006	1	Manifold-Intake				
③ 92009	92009-7003	6	Screw				
③ 92009A	92009-7005	4	Screw				
③ 92009B	92009-7006	1	Screw-Drain				
③ 92043	92043-7004	1	Pin-Float				
③ 92063	92063-7012	2	Jet-Main, No.108				
③ 92063A	92063-7013	1	Jet-Main, No.105				
③ 92063B	92063-7014	1	Jet-Main, No.102				
③ 92066	92066-7008	2	Plug-Jet, Main				
③ 92093	92093-7001	1	Seal				
③ 92093A	92093-7002	1	Seal				
③ 92145	92145-7005	1	Spring				
③ 92145A	92145-7011	1	Spring				
③ 92145B	92145-7013	2	Spring				
③ 92152	92152-7002	1	Collar				
③ 92191	92191-7010	1	Tube				
③ 130	130B0620	4	Bolt-Flanged				
③ 172	172G006105	2	Bolt-Stud				
③ 220	220B0520	1	Screw-Pan				

# Air Filter and Muffler Assembly Kawasaki FH721D-CS05-R

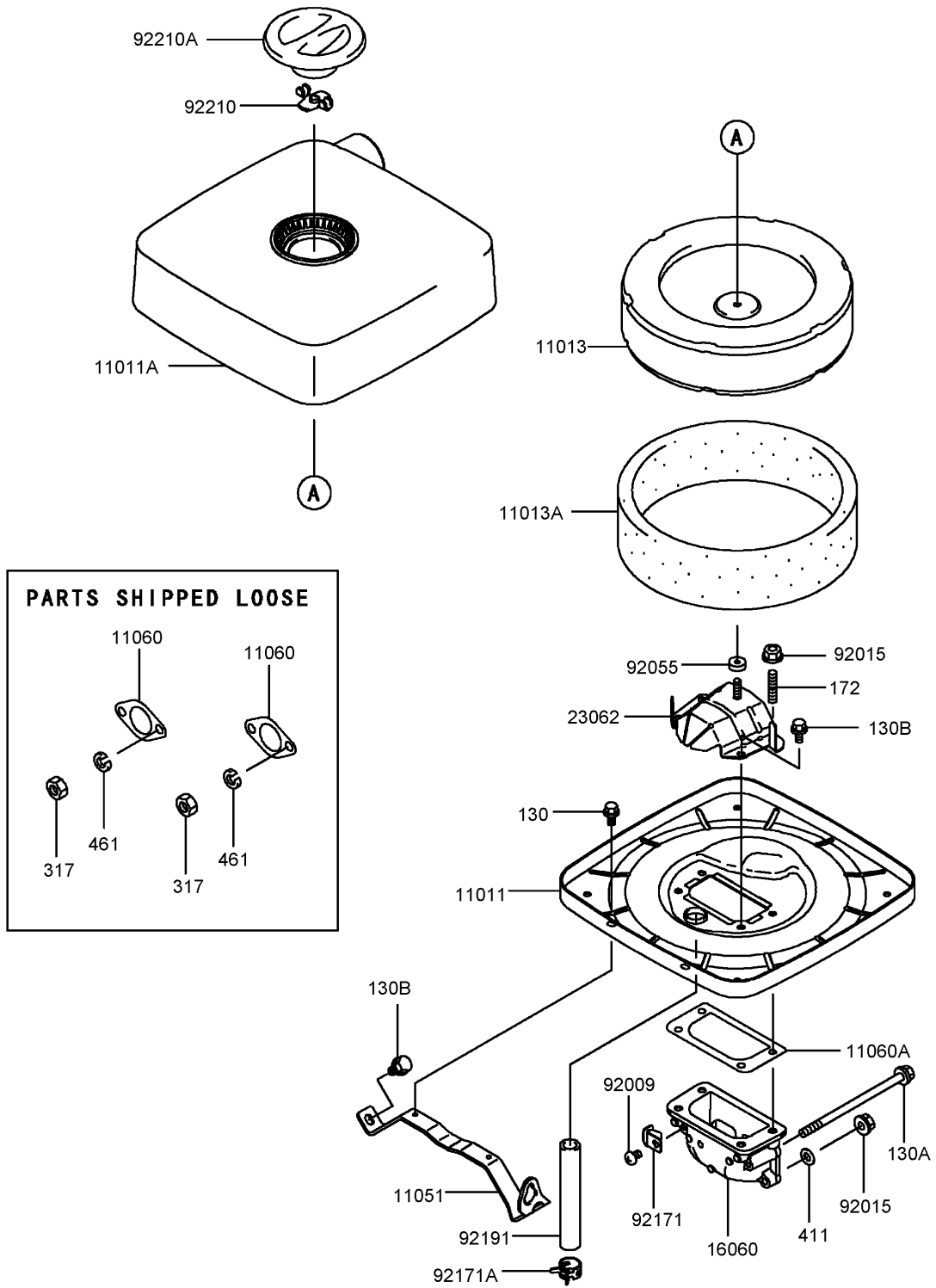

## Air Filter and Muffler Assembly Kawasaki FH721D-CS05-R

Ref	Part No.	Qty.	Description				
③11011	11011-7004	1	Case-Filter, Air				
③11011A	11011-7030	1	Case-Filter, Air				
③11013	11013-7022	1	Element-Filter, Air				
③11013A	11013-7023	1	Element-Filter, Air				
③11051	11051-7007	1	Bracket				
③11060	11060-7016	2	Gasket-Muffler				
③11060A	11060-7022	1	Gasket-Case, A/C				
③16060	16060-7004	1	Pipe-Intake				
③23062	23062-7006	1	Bracket				
③92009	92009-2166	1	Screw				
③92015	92015-1193	4	Nut				
③92055	92055-7005	1	O-Ring				
③92171	92171-7003	1	Clamp				
③92171A	92171-7013	1	Clamp				
③92191	92191-7020	1	Tube				
③92210	92210-7004	1	Nut				
③92210A	92210-7010	1	Nut				
③130	130B0510	2	Bolt-Flanged				
③130A	130B06105	2	Bolt-Flanged				
③130B	130B0612	4	Bolt-Flanged				
③172	172G0612	2	Bolt-Stud				
③317	317R0800	4	Nut-Hex				
③411	411b0600	1	Washer-Plain				
③461	461F0800	4	Washer-Spring				

# Fuel Tank and Valve Assembly Kawasaki FH721D-CS05-R

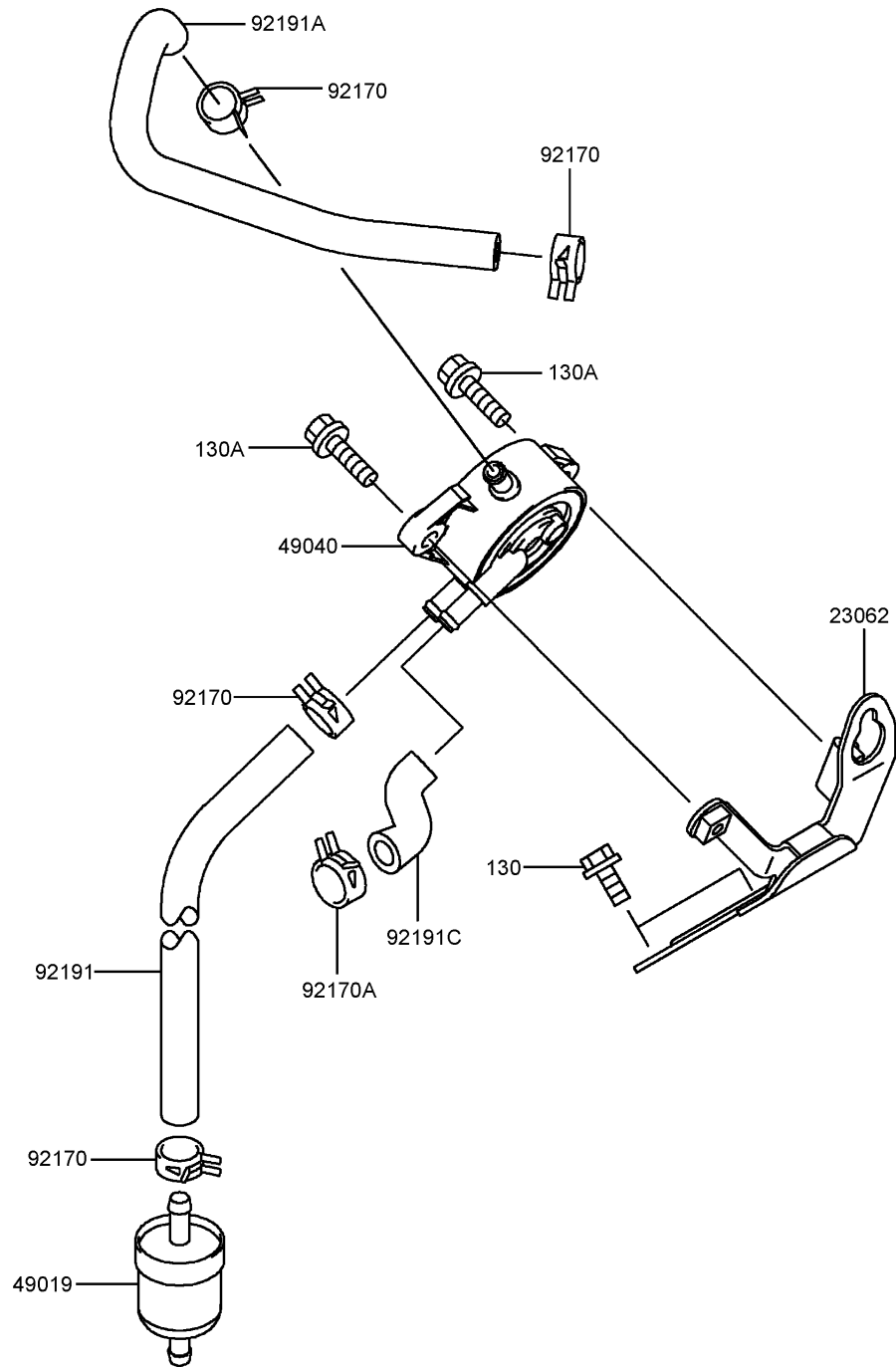

## Fuel Tank and Valve Assembly Kawasaki FH721D-CS05-R

Ref	Part No.	Qty.	Description				
③23062	23062-7004-9H	1	Bracket				
③49019	49019-7001	1	Filter-Fuel				
③49040	49040-7001	1	Pump-Fuel				
③92170	92170-2088	4	Clamp				
③92170A	92170-7003	1	Clamp				
③92191	92191-7003	1	Tube (6.35X12.7X160)				
③92191A	92191-7012	1	Tube				
③92191C	92191-7027	1	Tube				
③130	130B0616	2	Bolt-Flanged				
③130A	130B0620	2	Bolt-Flanged				





## Attachments and Accessories

### For 74248 - Z500 Z Master, With 52in 7-Gauge Side Discharge Mower

<b>Product Name</b>	<b>Model/Part</b>
Z Stand Kit .....	105-1622
Blade-Recycler, 18 Inch .....	105-7779-03
Blade-Hi Flow, 18 Inch .....	105-7781-03
Blade-Med Flow, 18 Inch .....	105-7794-03
Blade-Low Flow, 18 Inch .....	105-7795-03
Blade-Atomic, 18 Inch .....	105-7796-03
52 Inch Recycler Kit .....	107-1610
Striping Kit .....	107-1630
Turbo Baffle Kit .....	107-1634
Deluxe Suspension Seat .....	107-1891
Suspension Kit for Standard Seat .....	107-1892
52 Inch Twin Soft Bagger .....	78498
52 Inch TURBO FORCE Mower Finishing Kit .....	78512
DFS Vac Collection System, 2005 and After 500 Series Z Master .....	78513
Filter Minder Gauge .....	99-4664
Hitch Kit .....	99-8925

# NOTES

