



Count on it.

Operator's Manual

Commercial Walk-Behind Mower

For Fixed Deck, Pistol Grip, Hydro, with a 40in, 48in, or 52in TURBO FORCE[®] Cutting Unit

Model No. 30986—Serial No. 260000001 and Up

Model No. 30988—Serial No. 260000001 and Up

Model No. 30989—Serial No. 260000001 and Up

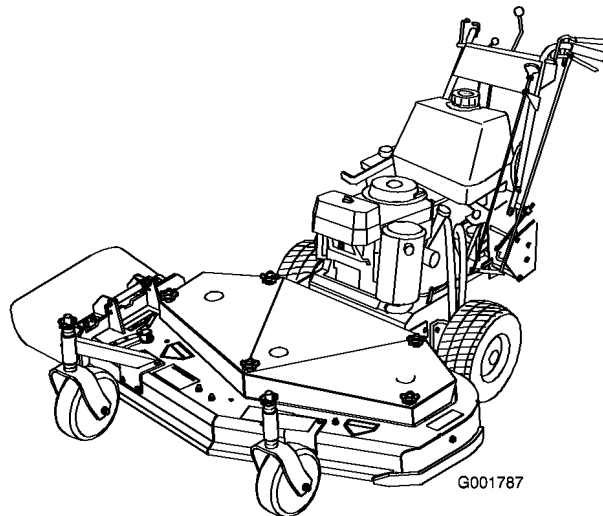

Warning

CALIFORNIA Proposition 65 Warning

The engine exhaust from this product contains chemicals known to the State of California to cause cancer, birth defects, or other reproductive harm.

This spark ignition system complies with Canadian ICES-002

Important: This engine is not equipped with a spark arrester muffler. It is a violation of California Public Resource Code Section 4442 to use or operate the engine on any forest-covered, brush-covered, or grass-covered land. Other states or federal areas may have similar laws.

The enclosed Engine Owner's Manual is supplied for information regarding the US Environmental Protection Agency (EPA) and the California Emission Control Regulation of emission systems, maintenance, and warranty. Replacements may be ordered through the engine manufacturer.

Introduction

Read this information carefully to learn how to operate and maintain your product properly and to avoid injury and product damage. You are responsible for operating the product properly and safely.

You may contact Toro directly at www.Toro.com for product and accessory information, help finding a dealer, or to register your product.

Whenever you need service, genuine Toro parts, or additional information, contact an Authorized Service Dealer or Toro Customer Service and have the model and serial numbers of your product ready. Figure 1 identifies the location of the model and serial numbers on the product. Write the numbers in the space provided.

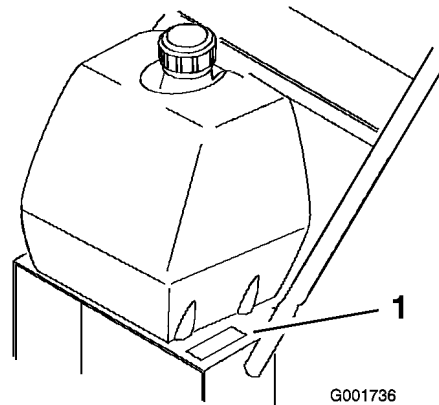

Figure 1

1. Model and serial number location

Model No. _____
Serial No. _____

This manual identifies potential hazards and has safety messages identified by the safety alert symbol (Figure 2), which signals a hazard that may cause serious injury or death if you do not follow the recommended precautions.



Figure 2

1. Safety alert symbol

This manual uses 2 other words to highlight information. **Important** calls attention to special mechanical information and **Note** emphasizes general information worthy of special attention.

Contents

Introduction	2
Safety	4
Safe Operating Practices	4
Toro Mower Safety	5
Slope Chart	7
Safety and Instructional Decals	8
Setup	11
1 Checking the Fluids and Tire Pressure	11
2 Reading the Manual and Viewing the Safety Video.....	11

Product Overview	12	Adjusting the Hydro Control	
Controls	12	Linkages.....	34
Specifications	13	Adjusting the Control Rod	36
Operation.....	14	Adjusting the Tracking	37
Adding Fuel	14	Adjusting the Spring Anchor	
Think Safety First.....	15	Links	37
Operating the Parking Brake	15	Checking the Tire Pressure.....	38
Starting and Stopping the		Cooling System Maintenance	38
Engine	15	Cleaning the Air Intake Screen	38
Operating the Neutral Locks.....	16	Cleaning the Cooling System.....	38
Operating the Mower Blade		Brake Maintenance	39
Control Knob		Servicing the Brake.....	39
(PTO)	17	Belt Maintenance.....	39
The Safety Interlock System.....	18	Checking the Belts	39
Driving the Machine Forward and		Replacing the Mower Belt	40
Backward	18	Adjusting the Mower Belt	
Bringing the Machine to Neutral		Tension	40
Position.....	19	Hydraulic System Maintenance	43
Stopping the Machine.....	19	Servicing the Hydraulic	
Pushing the Machine by Hand.....	19	System.....	43
Adjusting the Flow Baffle.....	20	Mower Deck Maintenance	45
Positioning the Flow Baffle	20	Servicing the Cutting Blades.....	45
Transporting Machines.....	22	Adjusting the Blade Brake	47
Side Discharging or Mulching the		Replacing the Grass Deflector.....	48
Grass.....	22	Storage.....	49
Adjusting the Height-of-Cut	22	Troubleshooting.....	50
Adjusting the Caster Position	23	Schematics	52
Adjusting the Handle Height.....	24		
Height-of-Cut Chart.....	25		
Maintenance.....	26		
Recommended Maintenance			
Schedule(s)	26		
Lubrication.....	27		
How to Grease	27		
Lubricating the Caster and Wheel			
Bearings	27		
Greasing the Mower Belt Idler.....	27		
Greasing the Pump Control and			
Bell Crank	27		
Engine Maintenance.....	27		
Servicing the Air Cleaner	27		
Servicing the Engine Oil	28		
Servicing the Spark Plugs	30		
Fuel System Maintenance	31		
Servicing the Fuel Tank.....	31		
Servicing the Fuel Filter	32		
Drive System Maintenance.....	32		
Adjusting the Speed Control			
Linkage	32		
Adjusting the Neutral Control			
Linkages.....	33		

Safety

Note: The addition of attachments made by other manufacturers that do not meet American National Standards Institute certification will cause noncompliance of this machine.

Improper use or maintenance by the operator or owner can result in injury. To reduce the potential for injury, comply with these safety instructions and always pay attention to the safety alert symbol **A**, which means CAUTION, WARNING, or DANGER—"personal safety instruction." Failure to comply with the instruction may result in personal injury or death.

Safe Operating Practices

The following instructions are from ANSI standard B71.4-2004.

Training

- Read the Operator's Manual and other training material. If the operator(s) or mechanic(s) can not read English it is the owner's responsibility to explain this material to them.
- Become familiar with the safe operation of the equipment, operator controls, and safety signs.
- All operators and mechanics should be trained. The owner is responsible for training the users.
- Never let children or untrained people operate or service the equipment. Local regulations may restrict the age of the operator.
- The owner/user can prevent and is responsible for accidents or injuries occurring to himself or herself, other people or property.

Preparation

- Evaluate the terrain to determine what accessories and attachments are needed to properly and safely perform the job. Only use accessories and attachments approved by the manufacturer.
- Wear appropriate clothing including hard hat, safety glasses and hearing protection. Long hair, loose clothing or jewelry may get tangled in moving parts.
- Inspect the area where the equipment is to be used and remove all objects such as rocks, toys and wire which can be thrown by the machine.

- Use extra care when handling gasoline and other fuels. They are flammable and vapors are explosive.
 - Use only an approved container
 - Never remove gas cap or add fuel with engine running. Allow engine to cool before refueling. Do not smoke.
 - Never refuel or drain the machine indoors.
- Check that operator's presence controls, safety switches and shields are attached and functioning properly. Do not operate unless they are functioning properly.

Operation

- Never run an engine in an enclosed area.
- Only operate in good light, keeping away from holes and hidden hazards.
- Be sure all drives are in neutral and parking brake is engaged before starting engine. Only start engine from the operator's position.
- Be sure of your footing while using this machine, especially when backing up. Walk, don't run. Never operate on wet grass. Reduced footing could cause slipping.
- Slow down and use extra care on hillsides. Be sure to travel side to side on hillsides. Turf conditions can affect the machine's stability. Use caution while operating near drop-offs.
- Slow down and use caution when making turns and when changing directions on slopes.
- Never raise deck with the blades running.
- Never operate with the PTO shield, or other guards not securely in place. Be sure all interlocks are attached, adjusted properly, and functioning properly.
- Never operate with the discharge deflector raised, removed or altered, unless using a grass catcher.
- Do not change the engine governor setting or overspeed the engine.
- Stop on level ground, disengage drives, engage parking brake (if provided), shut off engine before leaving the operator's position for any reason including emptying the catchers or unclogging the chute.

- Stop equipment and inspect blades after striking objects or if an abnormal vibration occurs. Make necessary repairs before resuming operations.
- Keep hands and feet away from the cutting unit.
- Look behind and down before backing up to be sure of a clear path.
- Keep pets and bystanders away.
- Slow down and use caution when making turns and crossing roads and sidewalks. Stop blades if not mowing.
- Be aware of the mower discharge direction and do not point it at anyone.
- Do not operate the mower under the influence of alcohol or drugs.
- Use care when loading or unloading the machine into or from a trailer or truck.
- Use care when approaching blind corners, shrubs, trees, or other objects that may obscure vision.

Maintenance and storage

- Disengage drives, set parking brake, stop engine and remove key or disconnect spark plug wire. Wait for all movement to stop before adjusting, cleaning or repairing.
- Clean grass and debris from cutting unit, drives, mufflers, and engine to help prevent fires. Clean up oil or fuel spillage.
- Let engine cool before storing and do not store near flame.
- Shut off fuel while storing or transporting. Do not store fuel near flames or drain indoors.
- Park machine on level ground. Set parking brake. Never allow untrained personnel to service machine.
- Use jack stands to support components when required.
- Carefully release pressure from components with stored energy.
- Disconnect the battery or remove spark plug wire before making any repairs. Disconnect the negative terminal first and the positive last. Reconnect the positive first and negative last.
- Use care when checking blades. Wrap the blade(s) or wear gloves, and use caution when

servicing them. Only replace blades. Never straighten or weld them.

- Keep hands and feet away from moving parts. If possible, do not make adjustments with the engine running.
- Keep all parts in good working condition and all hardware tightened. Replace all worn or damaged decals.

Toro Mower Safety

The following list contains safety information specific to Toro products and other safety information you must know.

This product is capable of amputating hands and feet and throwing objects. Always follow all safety instructions to avoid serious injury or death.

This product is designed for cutting and recycling grass or, when equipped with a grass bagger, for catching cut grass. Any use for purposes other than these could prove dangerous to user and bystanders.

General Operation

- Be sure the area is clear of other people before mowing. Stop the machine if anyone enters the area.
- Do not touch equipment or attachment parts which may be hot from operation. Allow to cool before attempting to maintain, adjust or service.
- Use only Toro-approved attachments. Warranty may be voided if used with unapproved attachments.
- Check carefully for overhead clearances (i.e. branches, doorways, electrical wires) before operating under any objects and do not contact them.

Slope Operation

All slopes and ramps require extra caution. If you feel uneasy on a slope, do not mow it.

- Remove obstacles such as rocks, tree limbs, etc. from the mowing area.
- Watch for holes, ruts or bumps. Tall grass can hide obstacles.
- Use caution near drop-offs, ditches, or embankments. The machine could suddenly

turn over if a wheel goes over the edge of a cliff or ditch, or if an edge caves in.

- Use extra care with grass catchers or other attachments. These can change the stability of the machine.
- Keep all movement on slopes slow and gradual. Do not make sudden changes in speed or direction.
- Mow slopes side to side.
- Do not mow slopes greater than 15 degrees.

Service

- Never store the machine or fuel container inside where there is an open flame, such as near a water heater or furnace.
- Keep nuts and bolts tight, especially the blade attachment bolts and nuts. Keep equipment in good condition.
- Never tamper with safety devices. Check safety systems for proper operation before each use.
- Use only genuine replacement parts to ensure that original standards are maintained.
- Check brake operation frequently. Adjust and service as required.

Slope Chart



Safety and Instructional Decals



Safety decals and instructions are easily visible to the operator and are located near any area of potential danger. Replace any decal that is damaged or lost.



1-523552



98-0776



43-8480

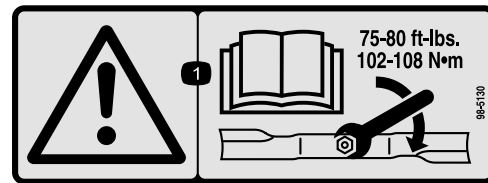

98-5130

1. Warning—read the *Operator's Manual* for instructions on torquing the blade bolt/nut to 75-80 ft-lb (102-106 N·m).



66-1340

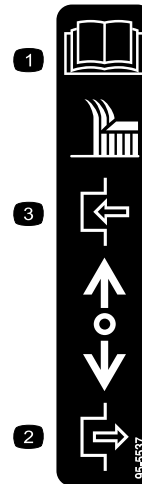

95-5537

1. Read the *Operator's Manual* for instructions on operating the cutting blade
2. Pull back to disengage
3. Push forward to engage

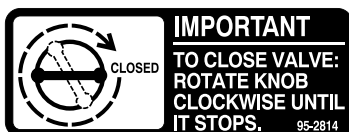

95-2814



98-5954



105-4110

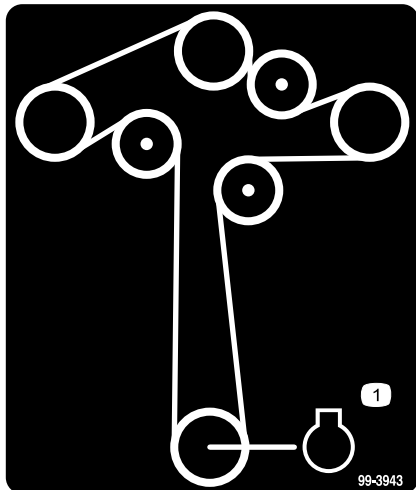

99-3943

1. Engine



106-0699

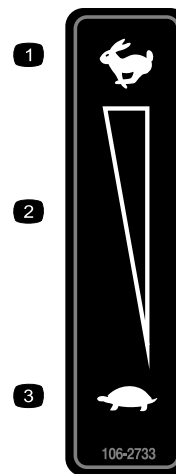

106-2733

- 1. Fast
- 2. Continuous variable setting
- 3. Slow



103-2103



104-8569



105-4109

106-2738

- | | | | |
|------------|---------------------------------|--------------------------------|-------------|
| 1. Park | 4. Engine—stop | 7. Fast | 10. Neutral |
| 2. Drive | 5. Engine—run | 8. Continuous variable setting | |
| 3. Neutral | 6. Warning—wear ear protection. | 9. Slow | |

⚠ CAUTION

- DRIVE SYSTEM MAY NOT HOLD MACHINE IF PARKED ON SLOPE.
- MOVEMENT OF AN UNATTENDED MACHINE CAN CAUSE PROPERTY DAMAGE OR PERSONAL INJURY.
- WHEELS MUST BE BLOCKED IF MACHINE IS PARKED ON SLOPE.
- WHEN POSSIBLE, PARK MACHINE ON LEVEL SURFACE.

106-2743

106-2743

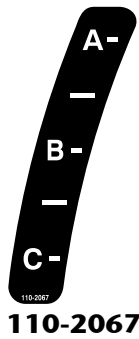

110-2067

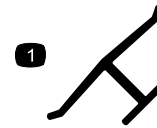

Manufacturer's Mark

1. Indicates the blade is identified as a part from the original machine manufacturer.

**ADJUSTABLE BAFFLE
BAFLE AJUSTABLE**

<p>A -</p> <ul style="list-style-type: none"> • Short, light grass • Dry conditions • Maximum dispersion 	<ul style="list-style-type: none"> • <i>Césped corto y ligero</i> • <i>Condiciones secas</i> • <i>Maxima dispersion</i> 	110-2068
<p>B -</p> <ul style="list-style-type: none"> • Bagging setting 	<ul style="list-style-type: none"> • <i>Posicion para usar con bolsa</i> 	
<p>C -</p> <ul style="list-style-type: none"> • Tall, dense grass • Wet conditions • Maximum ground speed 	<ul style="list-style-type: none"> • <i>Césped alto y denso</i> • <i>Condiciones mojadas</i> • <i>Maxima velocidad</i> 	

110-2068

1. Read the *Operator's Manual*.

Setup

Loose Parts

Use the chart below to verify that all parts have been shipped.

Step	Description	Qty.	Use
1	No parts required	–	Check the fluids and tire pressure.
2	Operator's Manual Engine Operator's Manual Parts Catalog Safety Video Registration Card Oil drain hose	1 1 1 1 1 1	Read the Operator's Manual and watch the video before operating the machine.

Note: Determine the left and right sides of the machine from the normal operating position.

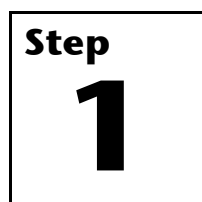

Checking the Fluids and Tire Pressure

No Parts Required

Procedure

- Before you start the engine and use the machine, check the oil level in the engine crankcase; refer to Checking the Engine Oil Level.
- Check the grease for the mower and mower deck.
- Check the tire pressure; refer to Checking the Tire Pressure.

Note: The cutting blades are set to a 3 inch (76mm) height-of-cut at initial purchase. The axle position is D, with 4 spacers below both the spindle and the caster.



Reading the Manual and Viewing the Safety Video

Parts needed for this step:

1	<i>Operator's Manual</i>
1	<i>Engine Operator's Manual</i>
1	<i>Parts Catalog</i>
1	<i>Safety Video</i>
1	<i>Registration Card</i>
1	<i>Oil drain hose</i>

Procedure

- Read the *Operator's Manual*.
- View the safety video.
- Fill out the registration card and mail it in or register online at www.Toro.com.
- Use the oil drain hose when changing the engine oil.

Product Overview

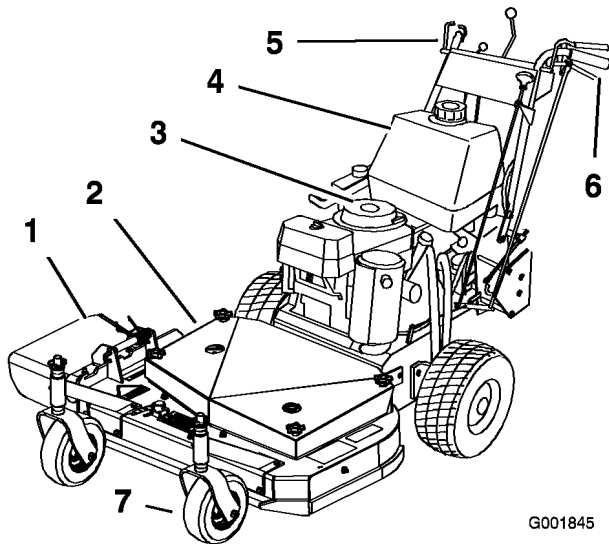

Figure 3

- | | |
|-------------------|-----------------|
| 1. Side discharge | 5. Controls |
| 2. Mower deck | 6. Handle |
| 3. Recoil starter | 7. Caster wheel |
| 4. Gas tank | |

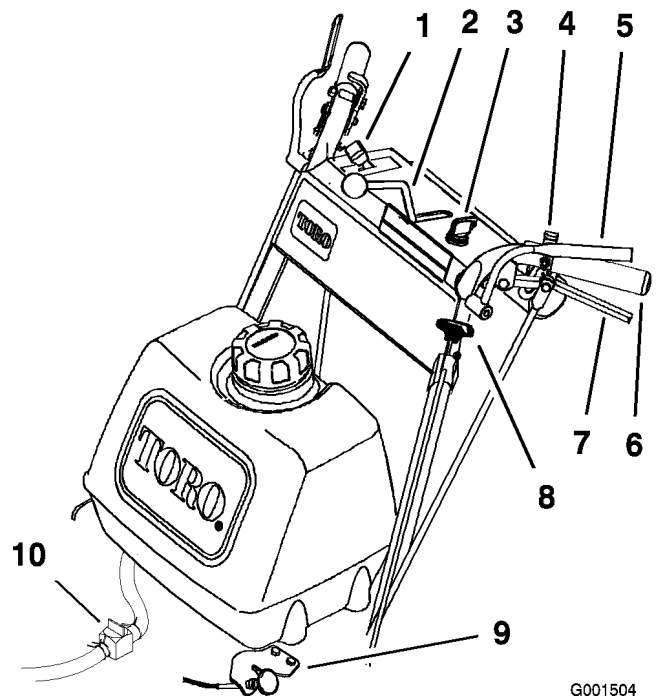

Figure 4

- | | |
|---|--------------------------------------|
| 1. Throttle control | 6. Handle |
| 2. Speed control lever | 7. Drive Lever |
| 3. Ignition switch | 8. Blade control knob (PTO) |
| 4. Neutral lock | 9. Choke |
| 5. Operator Presence Control levers (OPC) | 10. Fuel shut-off valve levers (OPC) |

Controls

Become familiar with all the controls (Figure 4) before you start the engine and operate the machine.

Throttle Control

The throttle control has two positions: **Fast** and **Slow**.

Operator Presence Control (OPC) Levers

When you squeeze the OPC levers against the handles, the OPC system senses that the operator is in the normal operating position. When you release the OPC levers, the OPC system senses that the operator has left the normal operating position, and the system will stop the engine if either the speed control lever is not in the **neutral** position or the blade control (PTO) knob is engaged.

Blade Control Knob (PTO)

The blade control knob (PTO) is used to engage and disengage the drive belt to drive the mower blades with the OPC levers pressed against the handles. Pull the knob up to engage the blades and down to disengage the blades.

Ignition Switch

This switch is used in conjunction with recoil starter and has two positions: **Run** and **Off**.

Speed Control Lever

This machine has a variable speed control with a neutral position. This controls how fast the machine will travel forward.

Drive Levers

Release drive levers to engage forward traction operation and squeeze the levers until an increase in force is felt to go into neutral position and continue to squeeze to go in reverse. Squeeze right side of drive lever to turn right and left side to turn left.

Neutral Lock

Squeeze drive levers back until an increase in force is felt and move locks to the rear for neutral lock.

Recoil Starter

Pull the recoil starter handle to start engine (Figure 3).

Fuel Shut-off Valve

Close the fuel shut-off valve when transporting or storing mower.

Choke

Use the choke to start a cold engine.

Specifications

Note: Specifications and design are subject to change without notice.

40 inch mowers:

Width with deflector down	55-1/2 inches (141 cm)
Length	75-3/8 inches (191.3 cm)
Height	44 inches (111.8 cm)
Weight	547 lb (248 kg)

48 inch mowers:

Width with deflector down	63-1/2 inches (161.3 cm)
Length	78-3/8 inches (198.9 cm)

Height	44 inches (111.8 cm)
Weight	570 lb (259 kg)

52 inch mowers:

Width with deflector down	67-5/8 inches (171.7 cm)
Length	79-3/8 inches (201.4 cm)
Height	44 inches (111.8 cm)
Weight	593 lb (269 kg)

Attachments/Accessories

A selection of Toro approved attachments and accessories are available for use with the machine to enhance and expand its capabilities. Contact your Authorized Service Dealer or Distributor or go to www.Toro.com for a list of all approved attachments and accessories.

Operation

Adding Fuel

Use **Unleaded** Regular Gasoline suitable for automotive use (85 pump octane minimum). Leaded regular gasoline may be used if unleaded regular is not available.

Important: Never use methanol, gasoline containing methanol, or gasohol containing more than 10% ethanol because the fuel system could be damaged. Do not mix oil with gasoline.



In certain conditions, gasoline is extremely flammable and highly explosive. A fire or explosion from gasoline can burn you and others and can damage property.

- Fill the fuel tank outdoors, in an open area, when the engine is cold. Wipe up any gasoline that spills.
- Never fill the fuel tank inside an enclosed trailer.
- Do not fill the fuel tank completely full. Add gasoline to the fuel tank until the level is 1/4 to 1/2 inch (6 to 13 mm) below the bottom of the filler neck. This empty space in the tank allows gasoline to expand.
- Never smoke when handling gasoline, and stay away from an open flame or where gasoline fumes may be ignited by a spark.
- Store gasoline in an approved container and keep it out of the reach of children. Never buy more than a 30-day supply of gasoline.
- Do not operate without entire exhaust system in place and in proper working condition.



In certain conditions during fueling, static electricity can be released causing a spark which can ignite the gasoline vapors. A fire or explosion from gasoline can burn you and others and can damage property.

- Always place gasoline containers on the ground away from your vehicle before filling.
- Do not fill gasoline containers inside a vehicle or on a truck or trailer bed because interior carpets or plastic truck bed liners may insulate the container and slow the loss of any static charge.
- When practical, remove gas-powered equipment from the truck or trailer and refuel the equipment with its wheels on the ground.
- If this is not possible, then refuel such equipment on a truck or trailer from a portable container, rather than from a gasoline dispenser nozzle.
- If a gasoline dispenser nozzle must be used, keep the nozzle in contact with the rim of the fuel tank or container opening at all times until fueling is complete.



Gasoline is harmful or fatal if swallowed. Long-term exposure to vapors can cause serious injury and illness.

- Avoid prolonged breathing of vapors.
- Keep face away from nozzle and gas tank or conditioner bottle opening.
- Keep gas away from eyes and skin.

Using Stabilizer/Conditioner

Use a fuel stabilizer/conditioner in the machine to provide the following benefits:

- Keeps gasoline fresh during storage of 90 days or less. For longer storage it is recommended that the fuel tank be drained.

- Cleans the engine while it runs
- Eliminates gum-like varnish buildup in the fuel system, which causes hard starting

Important: Do not use fuel additives containing methanol or ethanol.

Add the correct amount of gas stabilizer/conditioner to the gas.

Note: A fuel stabilizer/conditioner is most effective when mixed with fresh gasoline. To minimize the chance of varnish deposits in the fuel system, use fuel stabilizer at all times.

Filling the Fuel Tank

1. Shut the engine off and set the parking brake.
2. Clean around fuel tank cap and remove the cap. Add unleaded regular gasoline to fuel tank, until the level is 1/4 to 1/2 inch (6 to 13 mm) below the bottom of the filler neck. This space in the tank allows gasoline to expand. Do not fill the fuel tank completely full.
3. Install fuel tank cap securely. Wipe up any gasoline that may have spilled.

Think Safety First

Carefully read all the safety instructions and decals in the safety section. Knowing this information could help you or any bystanders avoid injury.

The use of protective equipment for eyes, hearing, feet and head is recommended.



This machine produces sound levels in excess of 85 dBA at the operator's ear and can cause hearing loss through extended periods of exposure.

Wear hearing protection when operating this machine.



Figure 5

1. Warning—wear hearing protection.

Operating the Parking Brake

Always set the parking brake when you stop the machine or leave it unattended. Before each use, check the parking brake for proper operation.

If the parking brake does not hold securely, adjust it. Refer to Servicing the Parking Brake.



Children or bystanders may be injured if they move or attempt to operate the machine while it is unattended.

Always remove the ignition key and set the parking brake when leaving the machine unattended, even if just for a few minutes.

Setting the Parking Brake

Pull the parking brake lever rearward (Figure 6).

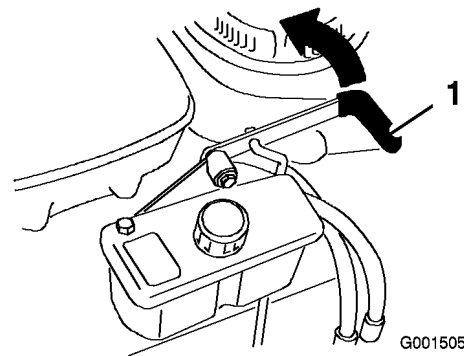

Figure 6

1. Parking brake lever (in the released position)

Releasing the Parking Brake

Push the parking brake lever forward.

Starting and Stopping the Engine

Starting the Engine

1. Connect the wires to the spark plugs.
2. Open the fuel valve.

Note: A cold weather starting kit has been incorporated to assist engine starting in cold weather or when the unit has not been run for a period of time.

To use the cold start kit:

- Grasp split ring (Figure 7) on right side of machine, pull ring and chain straight out from side of machine and hook ring over control shield bolt.

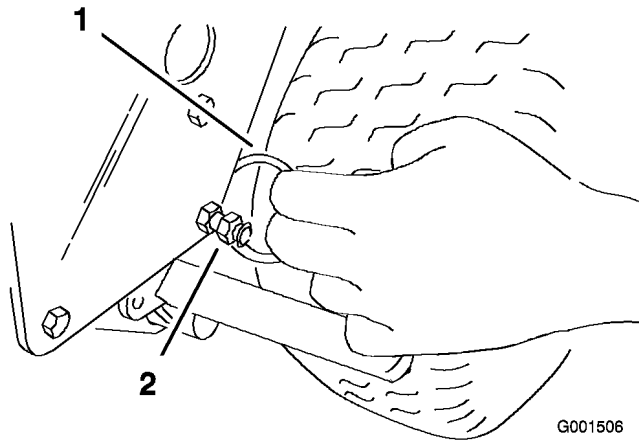

Figure 7

1. Split ring 2. Control shield bolt

- After the engine is started, pull the chain straight out from side of machine until ring can be removed from shield bolt. Slowly release tension on chain.

3. Disengage the blade control knob (PTO) and move the speed control lever to neutral.
 4. Move the drive levers to neutral and set the neutral locks.
 5. Set the parking brake.
 6. Turn the ignition key to the **run** position (Figure 4).
 7. To start a cold engine, move the throttle control midway between the **fast** and **slow** positions.
 8. To start a warm engine, move the throttle control to the **fast** position.
 9. Pull the choke knob if the engine is cold (Figure 4).
- Note:** A warm or hot engine usually does not require any choking.
10. Grasp the recoil starter handle firmly and pull it out until positive engagement results; then pull the handle vigorously to start the engine. Allow the rope to recoil slowly.

11. Push the choke to off as the engine warms up (Figure 8).
12. If the engine is cold, allow it to warm up and then move the throttle control to the **fast** position.

Stopping the Engine

1. Move the throttle lever to slow (Figure 8).
2. Move drive levers to neutral and set neutral locks.
3. Disengage the blade control knob (PTO) and move the speed control lever to neutral.
4. Let engine idle for 30 to 60 seconds before turning the engine off.
5. To stop the engine, turn the ignition key to off.

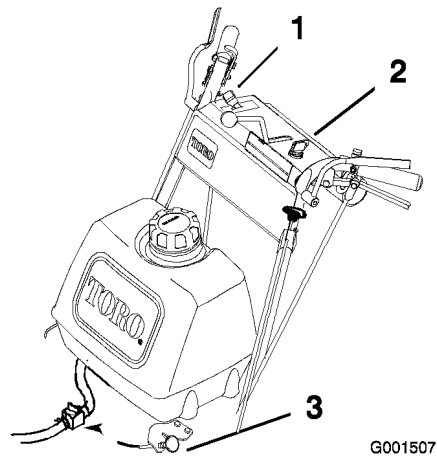

Figure 8

1. Throttle lever 3. Choke
2. Ignition switch

Important: Make sure fuel shut off valve is closed before transporting or storing machine, as fuel leakage may occur. Before storing machine, pull wire off spark plug(s) to prevent possibility of accidental starting.

Operating the Neutral Locks

Always set the neutral lock when you stop the machine. Set the parking brake if it is left unattended.

Setting the Neutral Lock

1. Squeeze the drive levers back until an increase in force is felt.
2. Place thumbs on the upper part of the locks and move them back (Figure 9).

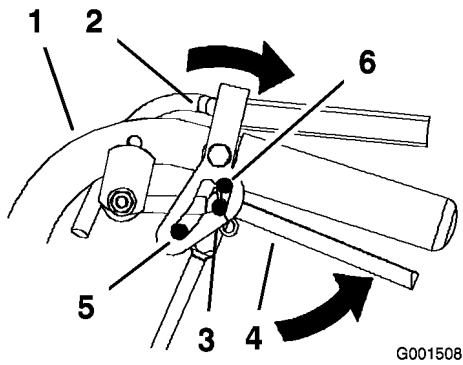

Figure 9

- | | |
|---------------------|-----------------------|
| 1. Handle | 4. Drive lever |
| 2. Neutral lock | 5. Full speed forward |
| 3. Neutral position | 6. Reverse position |

Releasing the Neutral Lock

1. Squeeze the drive levers back until an increase in force is felt.
2. Place thumbs on the upper part of locks and move them forward until the pins are in the forward slot (Figure 10).

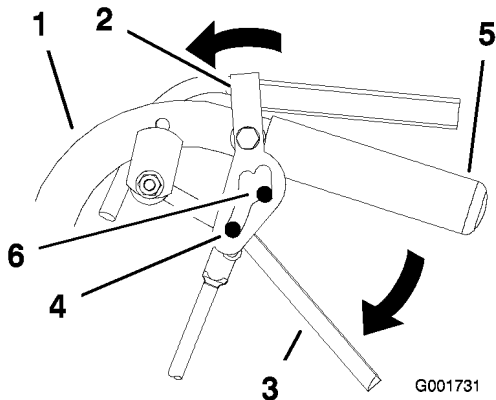

Figure 10

- | | |
|-----------------|------------------------------|
| 1. Handle | 4. Pin in full speed forward |
| 2. Neutral lock | 5. Handle |
| 3. Drive lever | 6. Forward slot |

Operating the Mower Blade Control Knob (PTO)

The blade control knob (PTO) is used in conjunction with the Operator Presence Control (OPC) levers to engage and disengage the mower blades.

Engaging the Mower Blades (PTO)

1. To engage blades, squeeze the Operator Presence Control (OPC) levers against handle grips (Figure 11).
2. Pull blade control knob (PTO) up. Hold the OPC levers against handle grip.

Note: The engine will kill if the OPC levers are released with the mower running.

3. Restart the engine and repeat the procedure to engage the mower blades if the operator presence control (OPC) levers are released.

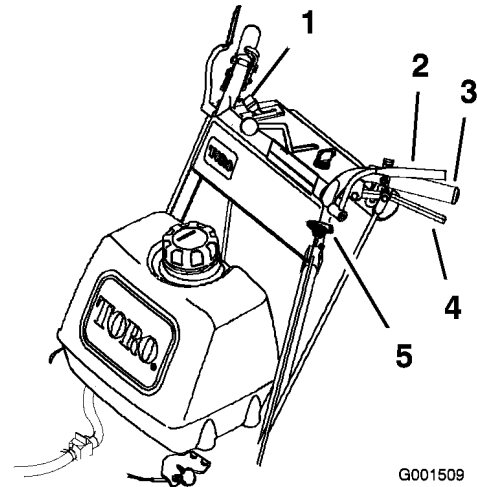

Figure 11

- | | |
|---|-----------------------------|
| 1. Throttle lever | 4. Drive Lever |
| 2. Operator Presence Control levers (OPC) | 5. Blade control knob (PTO) |
| 3. Handle | |

Disengaging the Mower Blades (PTO)

The mower blades can be disengaged by one of the following steps.

1. Push the blade control knob (PTO) down to off (Figure 11).
2. Releasing the Operator Presence Control (OPC) levers will kill the engine and stop the blades (Figure 11) with the blade control lever engaged.

The Safety Interlock System



If safety interlock switches are disconnected or damaged the machine could operate unexpectedly causing personal injury.

- Do not tamper with the interlock switches.
- Check the operation of the interlock switches daily and replace any damaged switches before operating the machine.

Understanding the Safety Interlock System

The safety interlock system is designed to prevent the mower from starting unless:

- The blade control knob (PTO) is pushed off.
- The speed control lever is in neutral.

The safety interlock system is designed to kill the engine when:

- The Operator Presence Control (OPC) levers are released with the mower engaged and/or the speed control is out of neutral.
- The speed control lever is shifted out of neutral without holding OPC levers or with the brake engaged.
- The blade control knob (PTO) is pulled up without holding the OPC levers.

Testing the Safety Interlock System

Test the safety interlock system before you use the machine each time. If the safety system does not operate as described, have an Authorized Service Dealer repair the safety system immediately.



While testing the safety interlock system, the machine may move forward and cause personal injury or property damage.

- Perform the safety interlock test in an open area.
- Ensure no one is standing in front of the machine while performing the safety interlock test.

1. Set the neutral locks and place speed control lever in neutral.
2. Start the engine; refer to Starting and Stopping the Engine.
3. Without holding the Operator Presence Control (OPC) levers, pull the blade control knob (PTO) up. The engine should kill.
4. Push the blade control knob down to off.
5. With engine running, hold down the OPC levers. Pull the blade control knob (PTO) up. The drive belt should engage and the mower blades begin rotating.
6. Release the OPC levers. The engine should kill.
7. With the engine running, move the speed control lever forward. Release the OPC levers. The engine should kill.
8. If all the above conditions are not met have an Authorized Service Dealer repair the safety system immediately.

Driving the Machine Forward and Backward

The throttle control regulates the engine speed as measured in RPM (revolutions per minute). Place the throttle control in the **fast** position for best mowing performance.

Driving Forward

1. Release the parking brake.
2. To go forward, move the speed control lever to desired speed.
3. Release the neutral lock. Refer to Releasing the Neutral Lock.
4. Slowly release the drive levers to move forward (Figure 12).

To go straight, release drive levers equally (Figure 12).

To turn, squeeze the drive lever on the side and direction you want to turn (Figure 12).

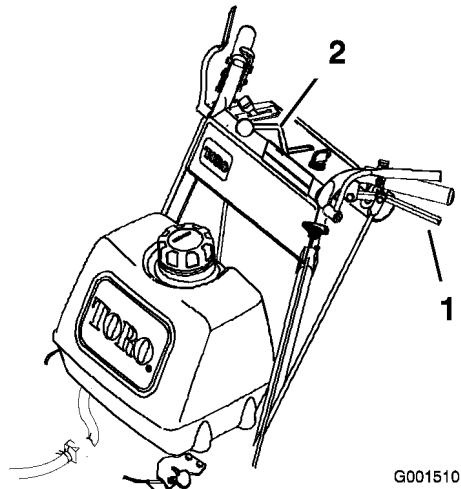

Figure 12

1. Drive lever 2. Speed control lever

Driving Backward

Slowly squeeze the drive levers back together to move rearward (Figure 12).

Bringing the Machine to Neutral Position

Always set the neutral lock and parking brake when you stop the machine.

1. Squeeze the drive levers to neutral position.
2. Set the neutral locks. Refer to Operating Neutral Locks.
3. Move speed control lever to neutral position.

Stopping the Machine

1. To stop the machine, squeeze the drive levers to neutral position and engage neutral locks.
2. Move speed control lever into neutral.
3. Stop the engine; refer to Stopping the Engine.
4. Wait for all moving parts to stop before leaving the operating position. Set the parking brake.



Children or bystanders may be injured if they move or attempt to operate the machine while it is unattended.

Always remove the ignition key and set the parking brake when leaving the machine unattended, even if just for a few minutes.

Pushing the Machine by Hand

The by-pass valves allow the machine to be pushed by hand without the engine running.

Important: Always push the machine by hand. Never tow the machine because hydraulic damage may occur.

To Push the Machine

1. Disengage the PTO, move the motion control levers to the neutral locked position and set the parking brake.
2. Open the by-pass valves by turning them counter clockwise 1 to 2. This allows hydraulic fluid to by-pass the pumps and the wheels to turn (Figure 13).
3. Release the parking brake.
4. Push the machine to the desired location.
5. Set the parking brake.
6. Close the by-pass valves, but do not overtighten them.

Note: Rotate the by-pass valves a maximum of 2 turns so the valve does not come out of the body causing fluid to run out.

Important: Do not start or operate the machine with the by-pass valves open. Damage to system may occur.

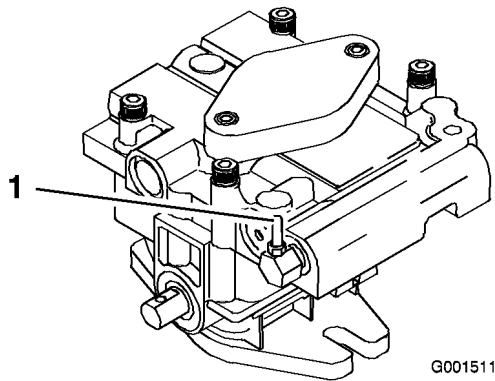

Figure 13

1. By-pass valve

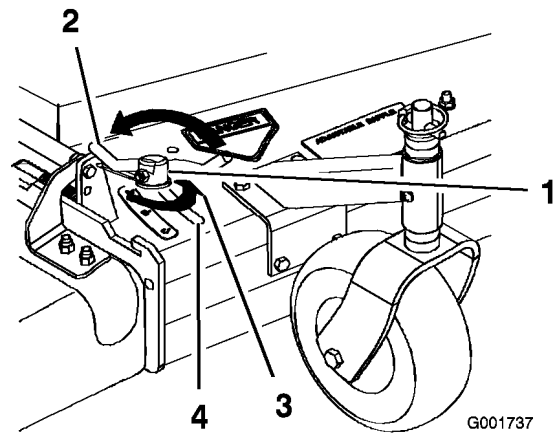

Figure 14

1. Cam lock
2. Lever
3. Rotate cam to increase or decrease locking pressure
4. Slot

Adjusting the Flow Baffle

The mower discharge flow can be adjusted for different types of mowing conditions. Position the cam lock and baffle to give the best quality of cut.

1. Disengage the PTO, move the motion control levers to the neutral locked position and set the parking brake.
2. Stop the engine, remove the key, and wait for all moving parts to stop before leaving the operating position.
3. To adjust the cam lock, swing the lever up to loosen the cam lock (Figure 14).
4. Adjust the baffle and cam lock in the slot to the desired discharge flow.
5. Swing the lever back over to tighten the baffle and cam lock (Figure 14).
6. If the cam does not lock the baffle into place or it is too tight, loosen the lever and then rotate the cam lock. Adjust the cam lock until the desired locking pressure is achieved.

Positioning the Flow Baffle

The following figures are only recommendations for use. Adjustments will vary by grass type, moisture content, and height of grass.

Note: If the engine power draws down and the mower ground speed is the same, open up the baffle.

Position A

This is the full rear position (see Figure 15). The suggested use for this position is as follows.

- Use for short, light grass mowing conditions.
- Use in dry conditions.
- For smaller grass clippings.
- Propels grass clippings farther away from the mower.

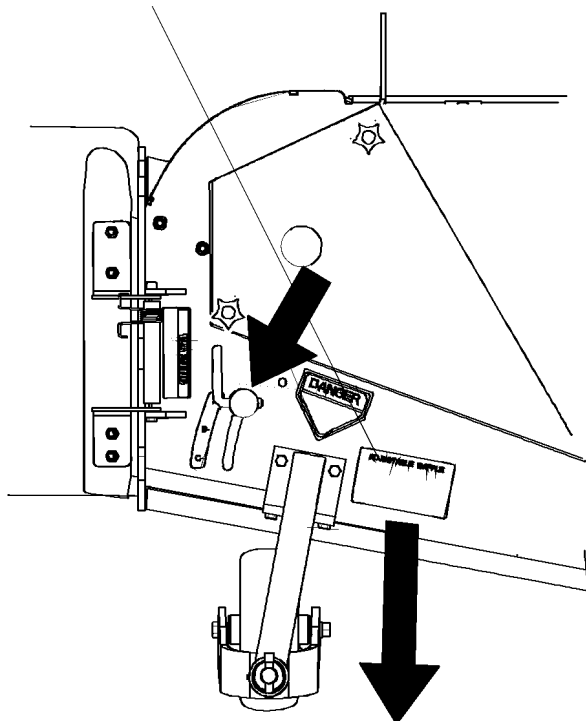

ADJUSTABLE Baffle
BAFLE AJUSTABLE

A	<ul style="list-style-type: none"> • Short, light grass • Dry conditions • Maximum dispersion 		<ul style="list-style-type: none"> • Césped corto y ligero • Condiciones secas • Máxima dispersión
B	<ul style="list-style-type: none"> • Bagging setting 		<ul style="list-style-type: none"> • Posición para usar con bolsa
C	<ul style="list-style-type: none"> • Tall, dense grass • Wet conditions • Maximum ground speed 		<ul style="list-style-type: none"> • Césped alto y denso • Condiciones mojadas • Máxima velocidad

G001738

Figure 15

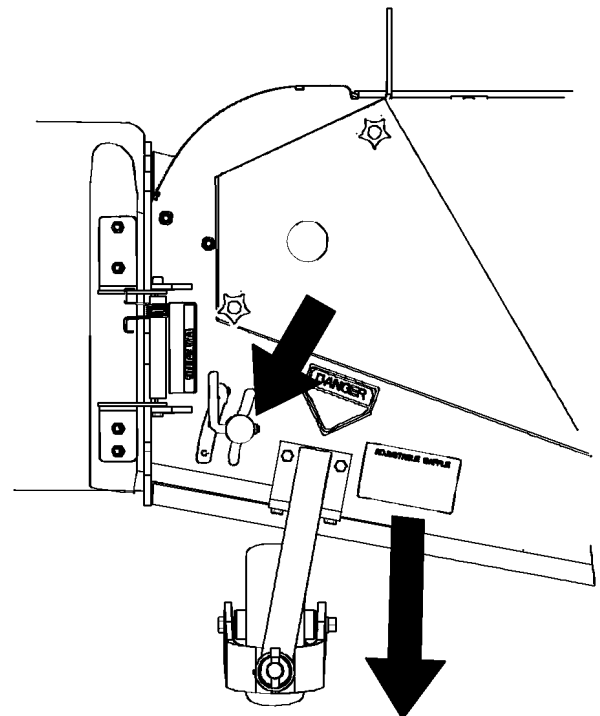

ADJUSTABLE Baffle
BAFLE AJUSTABLE

A	<ul style="list-style-type: none"> • Short, light grass • Dry conditions • Maximum dispersion 		<ul style="list-style-type: none"> • Césped corto y ligero • Condiciones secas • Máxima dispersión
B	<ul style="list-style-type: none"> • Bagging setting 		<ul style="list-style-type: none"> • Posición para usar con bolsa
C	<ul style="list-style-type: none"> • Tall, dense grass • Wet conditions • Maximum ground speed 		<ul style="list-style-type: none"> • Césped alto y denso • Condiciones mojadas • Máxima velocidad

G001739

Figure 16

Position B

Use this position when bagging (Figure 16).

Position C

This is the full open position. The suggested use for this position is as follows (Figure 17).

- Use in tall, dense grass mowing conditions.
- Use in wet conditions.
- Lowers the engine power consumption.
- Allows increased ground speed in heavy conditions.
- This position is similar to the benefits of the Toro SFS mower.

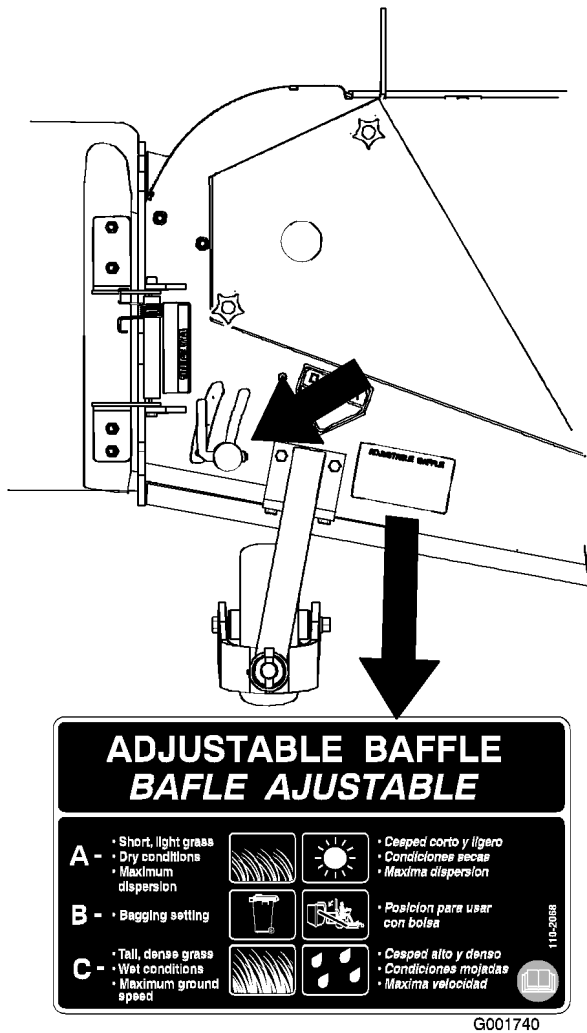

Figure 17

Transporting Machines

Use a heavy-duty trailer or truck to transport the machine. Ensure that the trailer or truck has all necessary lighting and marking as required by law. Please carefully read all the safety instructions. Knowing this information could help you, your family, pets or bystanders avoid injury.

To transport the machine:

- Stop the engine, remove the key, set the brake, and close the fuel valve.
- Securely fasten the machine to the trailer or truck with straps, chains, cable, or ropes.
- Secure a trailer to towing vehicle with safety chains.

Side Discharging or Mulching the Grass

This mower has a hinged grass deflector that disperses clippings to the side and down toward the turf.



Without the grass deflector, discharge cover, or complete grass catcher assembly mounted in place, you and others are exposed to blade contact and thrown debris. Contact with rotating mower blade(s) and thrown debris will cause injury or death.

- Never remove the grass deflector from the mower because the grass deflector routes material down toward the turf. If the grass deflector is ever damaged, replace it immediately.
- Never put your hands or feet under the mower.
- Never try to clear discharge area or mower blades unless you release the bail and the power take off (PTO) is off. Rotate the ignition key to Off. Also remove the key and pull the wire off the spark plug(s).

Adjusting the Height-of-Cut

This machine has a 1 to 4-1/4 inch (26 to 108 mm) range for height-of-cut. This can be achieved by adjusting blade spacers, rear axle height and front caster spacers. Use the Height-of-Cut chart to select the combination of adjustments required

Adjusting the Blade Height

Adjust the Blades by using the 4 spacers (1/4 inch) spacers on the blade spindle bolts. This allows for a 1-inch (25 mm) adjustment range of cutting height, in 1/4 inch (6 mm) increments, in any axle position. Use the same number of blade spacers on all blades to achieve a level cut (2 above and 2 below, 1 above and 3 below, etc.).

1. Disengage the PTO and pull the throttle to the slow position.

2. Turn the ignition switch to off.
3. Wait for all moving parts to stop before leaving the operating position. Set the parking brake.
4. Hold the blade bolt and remove the nut. Slide the bolt down through the spindle, and change the spacers as needed (Figure 18).

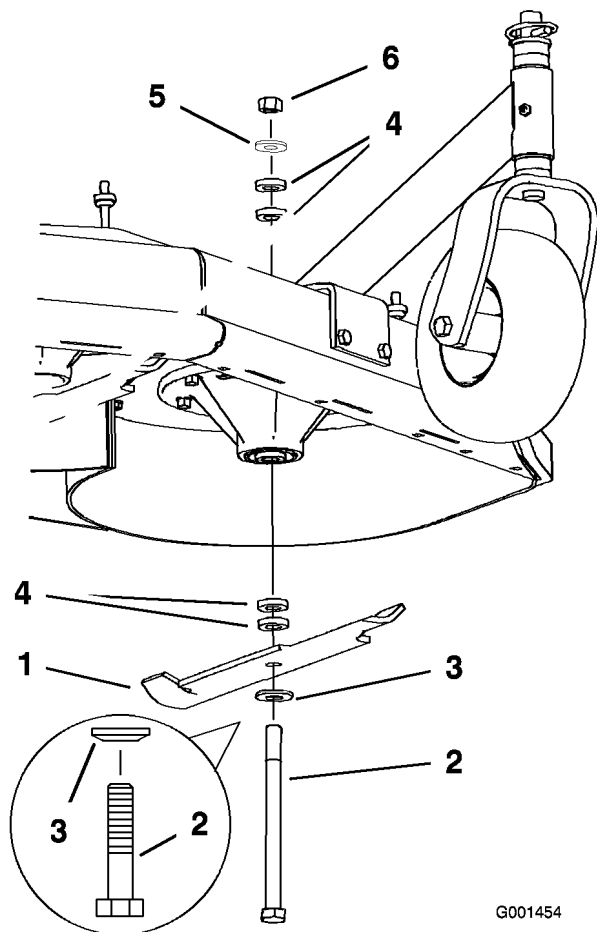

Figure 18

- | | |
|------------------|----------------|
| 1. Blade | 4. Spacer |
| 2. Blade bolt | 5. Thin washer |
| 3. Curved washer | 6. Nut |

5. Install the bolt, curved washer, blade, add extra spacers, and secure them with a thin washer and a nut (Figure 18).
6. Torque the blade bolt to 75-80 ft.-lb. (101-108 N•m).

Adjusting the Axle Height

Adjust the axle position to the selected height-of-cut setting.

1. Disengage the PTO and pull the throttle to the stop position.

2. Wait for all moving parts to stop before leaving the operating position and then set the parking brake.
3. Place a jack under the rear center of the engine frame. Raise the back end of the engine frame up enough to remove the drive wheels.
4. Remove the drive wheels.
5. Loosen, but do not remove, the 2 top axle bolts (Figure 19).
6. Remove the 2 lower axle bolts (Figure 19).

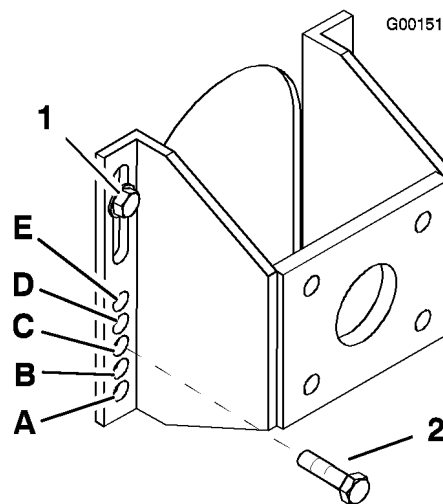

Figure 19

- | | |
|------------------|--------------------|
| 1. Top axle bolt | 2. Lower axle bolt |
|------------------|--------------------|

7. Raise or lower the mounting bracket, so that you can install the 2 axle adjustment bolts in the desired hole location (Figure 19). A tapered punch can be used to help align the holes.
8. Tighten all 4 bolts.
9. Install drive wheels and lower the mower.

Adjusting the Caster Position

1. Using the Height-of-Cut Chart, adjust the caster spacers to match with the axle hole selected (Figure 20).

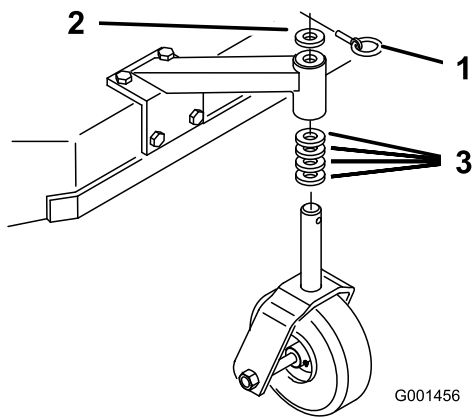

Figure 20

- | | |
|-----------------------------|-----------------------------|
| 1. Latch pin | 3. Spacer, 1/2 inch (13 mm) |
| 2. Spacer, 3/16 inch (5 mm) | |

- Remove the latch pin, slide the caster from the support, and change the spacers (Figure 20).
- Install the caster in the support and insert the latch pin (Figure 20).

Adjusting the Handle Height

The handle position can be adjusted to match the operator's height preference.

- Remove the hairpin cotter pins and clevis pins from the drive levers and neutral locks (Figure 21).

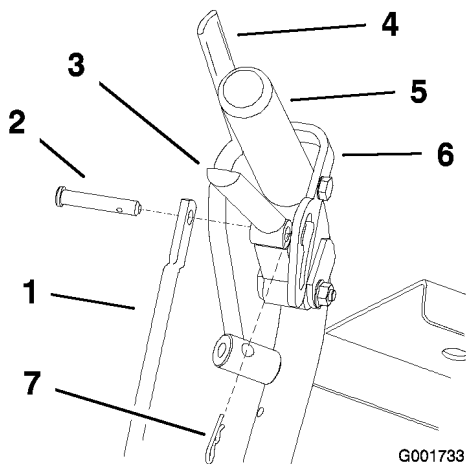

Figure 21

- | | |
|--|-----------------------|
| 1. Control rod | 5. Left handle shown |
| 2. Clevis pin | 6. Neutral lock |
| 3. Drive lever | 7. Hairpin cotter pin |
| 4. Operator Presence Control lever (OPC) | |

- Loosen the upper flange bolts (3/8 x 1-1/4 inch) and flange nut securing handle to rear frame (Figure 22).
- Remove the lower flange bolts (3/8 x 1 inch) and flange nuts securing handle to rear frame (Figure 22).
- Pivot handle to desired operating position and install lower flange bolts (3/8 x 1 inch) and flange nuts into mounting holes. Tighten all flange bolts.

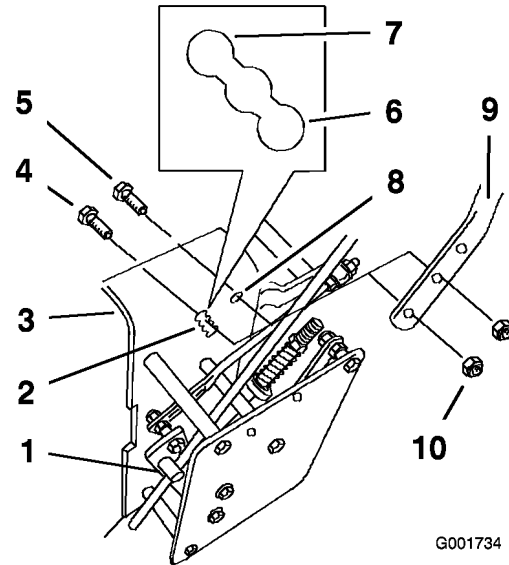

Figure 22

- | | |
|---|---------------------------|
| 1. Control rod fitting | 7. Lower position |
| 2. Lower mounting holes | 8. Upper mounting hole |
| 3. Rear frame | 9. Handle |
| 4. Lower flange bolt (3/8 x 1 inch) | 10. Flange nut (3/8 inch) |
| 5. Upper flange bolt (3/8 x 1-1/4 inches) | 11. |
| 6. High position | |

- Adjust the control rod length by rotating the control rod in the rod fitting (Fig. 8).
 - Install hairpin cotter between drive levers and neutral locks and into clevis pins (Fig. 25).
- Note:** Make sure the clevis pins are inserted into the neutral locks.
- Perform the hydraulic linkage adjustments when the handle height is changed; refer Hydraulic Linkage Adjustments.

Height-of-Cut Chart

Axle Position	Number of spacers below caster		Number of 1/4 inch blade spacers below spindle				
	1/2 inch (13mm)	3/16 inch (5 mm)	4	3	2	1	0
A	0	0	1 inch (26 mm)	1-1/4 inch (32 mm)	1-1/2 inch (38 mm)	1-3/4 inch (45 mm)	2 inch (29 mm)
A	0	1	1-1/8 inch (29 mm)	1-3/8 inch (29 mm)	1-5/8 inch (29 mm)	1-7/8 inch (29 mm)	2-1/8 inch (55 mm)
A	1	0	1-3/8 inch (35 mm)	1-5/8 inch (29 mm)	1-7/8 inch (29 mm)	2-1/8 inch (55 mm)	2-3/8 inch (29 mm)
B	0	1	1-3/8 inch (35 mm)	1-1/8 inch (29 mm)	1-1/8 inch (29 mm)	2-1/8 inch (55 mm)	1-1/8 inch (29 mm)
B	1	0	1-5/8 inch (41 mm)	1-1/8 inch (29 mm)	2-1/8 inch (55 mm)	1-1/8 inch (29 mm)	1-1/8 inch (29 mm)
B	1	1	1-3/4 inch (45 mm)	1-1/8 inch (29 mm)	2-1/4 inch (58 mm)	2-1/2 inch (64 mm)	2-3/4 inch (70 mm)
B	2	0	2 inch (50 mm)	2-1/4 inch (58 mm)	2-1/2 inch (64 mm)	2-3/4 inch (70 mm)	1-1/8 inch (29 mm)
C	1	1	1-7/8 inch (48 mm)	2-1/8 inch (55 mm)	1-1/8 inch (29 mm)	1-1/8 inch (29 mm)	2-7/8 inch (73 mm)
C	2	0	2-1/8 inch (55 mm)	1-1/8 inch (29 mm)	1-1/8 inch (29 mm)	2-7/8 inch (73 mm)	3-1/8 inch (79 mm)
C	2	1	2-1/4 inch (58 mm)	2-1/2 inch (64 mm)	2-3/4 inch (70 mm)	3 inch (76 mm)	3-1/4 inch (82 mm)
C	3	0	2-1/2 inch (64 mm)	2-3/4 inch (70 mm)	3 inch (76 mm)	3-1/4 inch (82 mm)	3-1/2 inch (89 mm)
D	2	1	2-3/8 inch (61 mm)	1-1/8 inch (29 mm)	2-7/8 inch (73 mm)	3-1/8 inch (79 mm)	3-3/8 inch (86 mm)
D	3	0	2-1/2 inch (64 mm)	2-3/4 inch (70 mm)	3 inch (76 mm)	3-1/4 inch (82 mm)	3-1/2 inch (89 mm)
D	3	1	2-3/4 inch (70 mm)	3 inch (76 mm)	3-1/4 inch (82 mm)	3-1/2 inch (89 mm)	3-3/4 inch (96 mm)
D	4	0	3 inch (76 mm)	3-1/4 inch (82 mm)	3-1/2 inch (89 mm)	3-3/4 inch (96 mm)	4 inch (102 mm)
E	3	1	2-7/8 inch (73 mm)	3-1/8 inch (79 mm)	3-3/8 inch (86 mm)	3-5/8 inch (92 mm)	3-7/8 inch (99 mm)
E	4	0	3-1/8 inch (79 mm)	3-3/8 inch (86 mm)	3-5/8 inch (92 mm)	3-7/8 inch (99 mm)	4-1/8 inch (105 mm)
E	4	1	3-1/4 inch (82 mm)	3-1/2 inch (89 mm)	3-3/4 inch (96 mm)	4 inch (102 mm)	4-1/4 inch (108 mm)

Maintenance

Note: Determine the left and right sides of the machine from the normal operating position.

Recommended Maintenance Schedule(s)

Maintenance Service Interval	Maintenance Procedure
After the first 8 operating hours	<ul style="list-style-type: none"> • Change the engine oil. • Check the mower belt tension.
After the first 25 operating hours	<ul style="list-style-type: none"> • Check the mower belt tension.
Before each use or daily	<ul style="list-style-type: none"> • Check the safety system. • Grease the caster wheels and caster pivot. • Check the engine oil level. • Clean the air intake screen. • Inspect the blades. • Clean the mower deck.
Every 25 hours	<ul style="list-style-type: none"> • Clean foam air cleaner element.
Every 50 hours	<ul style="list-style-type: none"> • Grease the mower belt idler. • Grease the pump drive idler pivot. • Grease the pump control. • Check the paper air cleaner element. • Check the tire pressure. • Check the belts. • Check the mower belt tension.
Every 100 hours	<ul style="list-style-type: none"> • Grease the blade engagement bellcrank. • Change the engine oil. • Check the spark plugs. • Check and clean engine cooling fins and shrouds.
Every 200 hours	<ul style="list-style-type: none"> • Replace the paper air cleaner element. • Replace the oil filter. • Replace the fuel filter.
Every 400 hours	<ul style="list-style-type: none"> • Lubricate cam lock with Never-Seez®.
Before storage	<ul style="list-style-type: none"> • Paint chipped surfaces. • Perform all maintenance procedures listed above before storage.

Important: Refer to your engine operator’s manual for additional maintenance procedures.



If you leave the key in the ignition switch, someone could accidentally start the engine and seriously injure you or other bystanders.

Remove the key from the ignition and disconnect the spark plug wire from the spark plug(s) before you do any maintenance. Set the wire aside so that it does not accidentally contact the spark plug.

Lubrication

Use Figure 23 for locating the grease points on the machine.

Grease with No. 2 general purpose lithium base or molybdenum base grease.

How to Grease

1. Disengage the PTO and set the parking brake.
2. Stop the engine, remove the key, and wait for all moving parts to stop before leaving the operating position.
3. Clean the grease fittings with a rag. Make sure to scrape any paint off the front of the fitting(s).
4. Connect a grease gun to the fitting. Pump grease into the fittings until grease begins to ooze out of the bearings.
5. Wipe up any excess grease.

Lubricating the Caster and Wheel Bearings

Lubricate the front wheel bearings and front spindles (Figure 23).

Greasing the Mower Belt Idler

Grease the fitting on the mower belt idler arm pivot (Figure 23).

Note: Remove the mower deck cover to access the grease fitting for the mower belt idler arm.

Greasing the Pump Control and Bell Crank

Grease the fitting on the pump drive idler pivot and the pump control every 50 hours.

Grease the blade engagement (PTO) bellcrank every 100 hours (Figure 23).

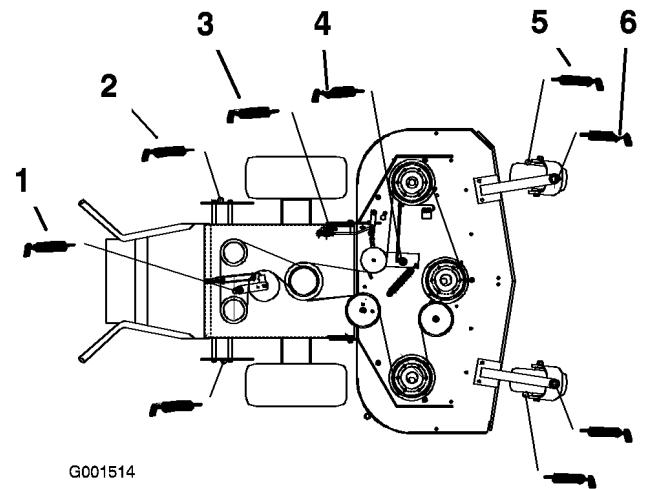

Figure 23

- | | |
|-------------------------|-------------------------|
| 1. Pump drive idler arm | 4. Mower belt idler arm |
| 2. Pump control arm | 5. Caster wheel bearing |
| 3. Bellcrank | 6. Caster pivot |

Engine Maintenance

Servicing the Air Cleaner

Service Interval/Specification

Foam element: Clean it after every 25 operating hours.

Paper element: Check it after every 50 operating hours. Replace it after every 200 operating hours or yearly, whichever comes first.

Inspect the foam and paper elements and replace them if they are damaged or excessively dirty.

Note: Service the air cleaner more frequently (every few operating hours) if the operating conditions are extremely dusty or sandy.

Important: Do not oil the foam or paper element.

Removing the Foam and Paper Elements

1. Disengage the PTO and set the parking brake.
2. Stop the engine, remove the key, and wait for all moving parts to stop before leaving the operating position.
3. Clean around the air cleaner to prevent dirt from getting into the engine and causing damage (Figure 24).

4. Unscrew the cover knob and remove the air cleaner cover (Figure 24).
5. Remove the 2 wing nuts and remove the air cleaner assembly (Figure 24).
6. Carefully pull the foam element off the paper element (Figure 24).

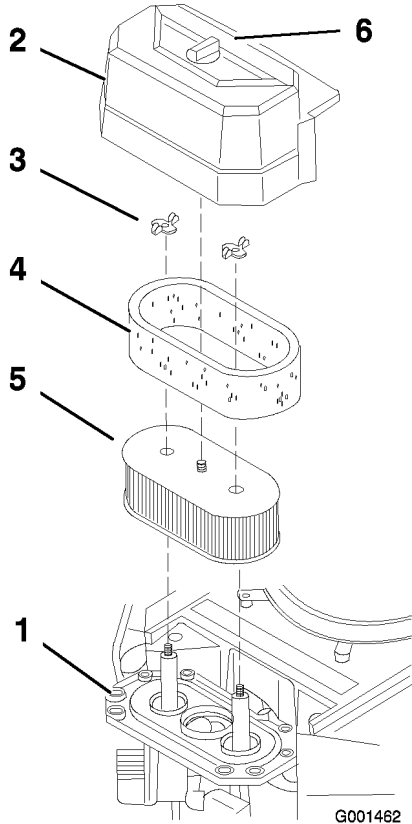

Figure 24

- | | |
|-------------|------------------|
| 1. Engine | 4. Foam element |
| 2. Cover | 5. Paper element |
| 3. Wing nut | 6. Cover knob |

Cleaning the Foam Air Cleaner Element

1. Wash the foam element in liquid soap and warm water. When the element is clean, rinse it thoroughly.
2. Dry the element by squeezing it in a clean cloth.

Important: Replace the foam element if it is torn or worn.

Servicing the Paper Air Cleaner Element

1. Do not clean the paper filter. Replace it after 200 operating hours (Figure 24).

2. Inspect the element for tears, an oily film, or damage to the rubber seal.
3. Replace the paper element if it is damaged.

Installing the Foam and Paper Elements

Important: To prevent engine damage, always operate the engine with the complete foam and paper air cleaner assembly installed.

1. Carefully slide the foam element onto the paper air cleaner element (Figure 24).
2. Place the air cleaner assembly onto the air cleaner base and secure it with the 2 wing nuts (Figure 24).
3. Place the air cleaner cover into position and tighten the cover knob (Figure 24).

Servicing the Engine Oil

Service Interval/Specification

Change the engine oil as follows:

- After the first 8 operating hours
- After every 100 operating hours

Note: Change the oil more frequently when the operating conditions are extremely dusty or sandy.

Oil Type: Detergent oil (API service SF, SG, SH, or SJ)

Crankcase Capacity: 58 ounces (1.7 liter) with the filter removed; 51 ounces (1.5 liter) without the filter removed

Viscosity: Refer to the table (Figure 25).

USE THESE SAE VISCOSITY OILS

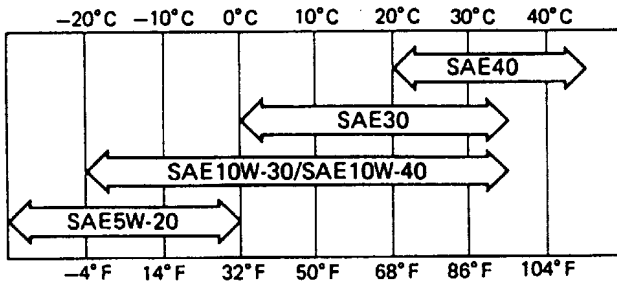

G001463

Figure 25

Checking the Engine Oil Level

1. Park the machine on a level surface.
2. Disengage the PTO and set the parking brake.
3. Stop the engine, remove the key, and wait for all moving parts to stop before leaving the operating position.
4. Clean around the oil dipstick (Figure 26) so that dirt cannot fall into the filler hole and damage the engine.

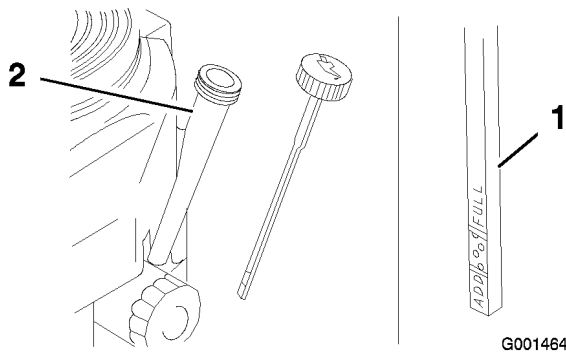

G001464

Figure 26

1. Oil dipstick
2. Filler tube

5. Unscrew the oil dipstick and wipe the end clean (Figure 26).
6. Slide the oil dipstick fully into the filler tube, but do not thread onto tube (Figure 26).
7. Pull the dipstick out and look at the end. If the oil level is low, slowly pour only enough oil into the filler tube to raise the level to the Full mark.

Important: Do not overfill the crankcase with oil and run the engine; engine damage can result.

Changing the Oil

1. Start the engine and let it run five minutes. This warms the oil so it drains better.
2. Park the machine so that the drain side is slightly lower than the opposite side to assure the oil drains completely.
3. Disengage the PTO and set the parking brake.
4. Stop the engine, remove the key, and wait for all moving parts to stop before leaving the operating position.
5. Slide the drain hose over the oil drain valve.
6. Place a pan below the drain hose. Rotate oil drain valve to allow oil to drain (Figure 27).
7. When oil has drained completely, close the drain valve.
8. Remove the drain hose (Figure 27).

Note: Dispose of the used oil at a recycling center.

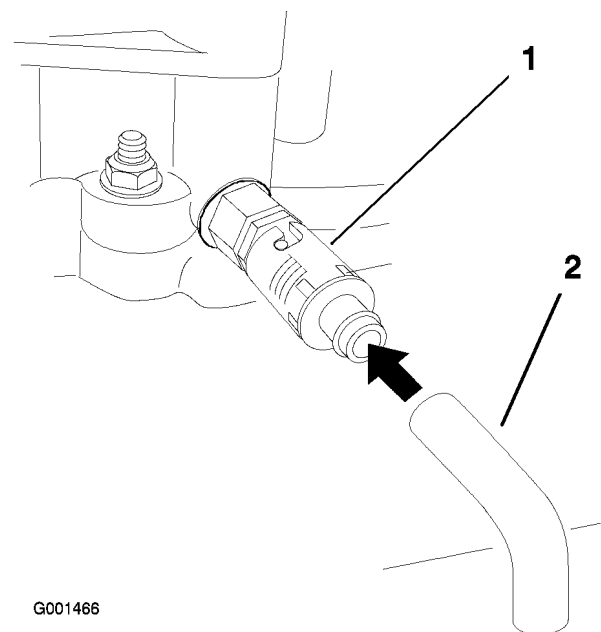

G001466

Figure 27

1. Oil drain valve
2. Oil drain hose

9. Slowly pour approximately 80% of the specified oil into the filler tube (Figure 26).
10. Check the oil level; refer to Checking the Engine Oil Level.
11. Slowly add the additional oil to bring it to the **Full** mark.

Changing the Oil Filter

Replace the oil filter every 200 operating hours or every other oil change.

Note: Change the oil filter more frequently when the operating conditions are extremely dusty or sandy.

1. Drain the oil from the engine; refer to Changing the Engine Oil.
2. Remove the old filter (Figure 28).

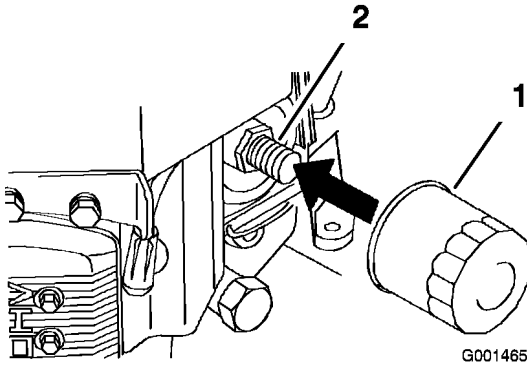

Figure 28

1. Oil filter
2. Adapter

3. Apply a thin coat of new oil to the rubber gasket on the replacement filter (Figure 28).
4. Install the replacement oil filter to the filter adapter, turn the oil filter clockwise until the rubber gasket contacts the filter adapter, then tighten the filter an additional 3/4 turn (Figure 28).
5. Fill the crankcase with the proper type of new oil; refer to Servicing the Engine Oil.
6. Run the engine for about 3 minutes, stop the engine, and check for oil leaks around the oil filter and drain valve.
7. Check the engine oil level and add oil if needed.

Servicing the Spark Plugs

Service Interval/Specification

Check the spark plugs after every 100 operating hours.

Ensure that the air gap between the center and side electrodes is correct before installing the spark plug. Use a spark plug wrench for removing and

installing the spark plugs and a gapping tool/feeler gauge to check and adjust the air gap. Install a new spark plugs if necessary.

Type: Champion® RCJ8Y or equivalent Air Gap: 0.030 inch (0.75 mm)

Removing the Spark Plugs

1. Disengage the PTO and set the parking brake.
2. Stop the engine, remove the key, and wait for all moving parts to stop before leaving the operating position.
3. Disconnect the wires from the spark plugs (Figure 29).

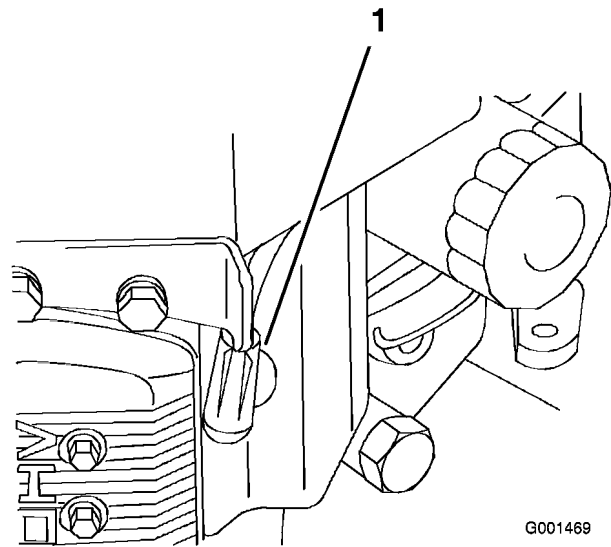

Figure 29

1. Spark-plug wire/spark plug
4. Clean around the spark plugs to prevent dirt from falling into the engine and potentially causing damage.
5. Remove the spark plugs and the metal washers.

Checking the Spark Plugs

1. Look at the center of the spark plugs (Figure 30). If you see light brown or gray on the insulator, the engine is operating properly. A black coating on the insulator usually means that the air cleaner is dirty.
2. If needed, clean the spark plug with a wire brush to remove carbon deposits.

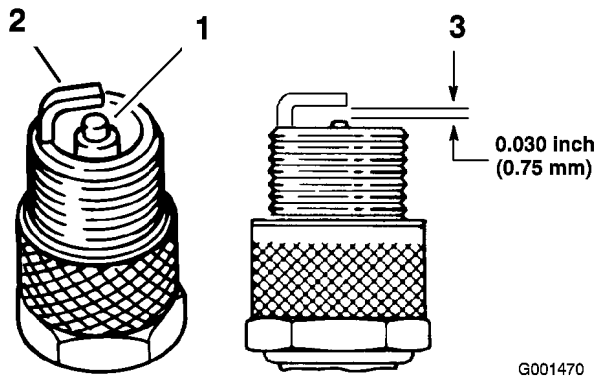

Figure 30

1. Center electrode insulator
2. Side electrode
3. Air gap (not to scale)

Important: Always replace the spark plugs when it has a black coating, worn electrodes, an oily film, or cracks.

3. Check the gap between the center and side electrodes (Figure 30). Bend the side electrode (Figure 30) if the gap is not correct.

Installing the Spark Plugs

1. Install the spark plugs and the metal washer. Ensure that the air gap is set correctly.
2. Tighten the spark plugs to 16 ft-lb (22 N•m).
3. Connect the wires to the spark plugs (Figure 30).

Fuel System Maintenance

Servicing the Fuel Tank



In certain conditions, gasoline is extremely flammable and highly explosive. A fire or explosion from gasoline can burn you and others and can damage property.

- Drain gasoline from the fuel tank when the engine is cold. Do this outdoors in an open area. Wipe up any gasoline that spills.
- Never smoke when draining gasoline, and stay away from an open flame or where a spark may ignite the gasoline fumes.

Draining the Fuel Tank

1. Park the machine on a level surface, to assure fuel tank drains completely. Then disengage the power take off (PTO), set the parking brake, and turn the ignition key to **off**. Remove the key.
2. Close the fuel shut-off valve at the fuel tank (Figure 31).
3. Squeeze the ends of the hose clamp together and slide it up the fuel line away from fuel filter (Figure 31).
4. Pull the fuel line off the fuel filter (Figure 31). Open the fuel shut-off valve and allow the gasoline to drain into a gas can or drain pan.

Note: Now is the best time to install a new fuel filter because the fuel tank is empty. Refer to Replacing the Fuel Filter.

5. Install the fuel line onto the fuel filter. Slide the hose clamp close to the valve to secure the fuel line.

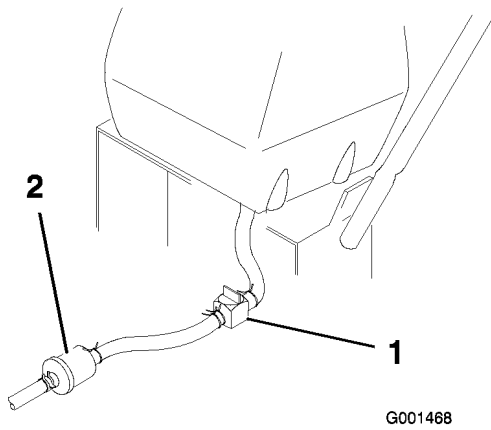

Figure 31

1. Fuel shut-off valve 2. Clamp

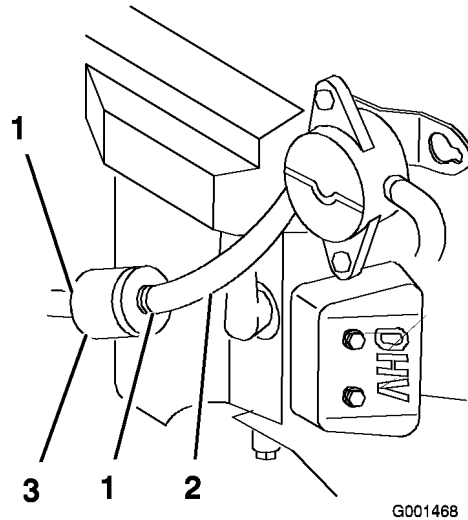

Figure 32

1. Hose clamp 3. Filter
2. Fuel line

Servicing the Fuel Filter

Replace the fuel filter after every 200 operating hours or yearly, whichever occurs first.

Replacing the Fuel Filter

Never install a dirty filter if it is removed from the fuel line.

Note: Note how the fuel filter is installed in order to install the new filter correctly.

Note: Wipe up any spilled fuel.

1. Disengage the PTO and set the parking brake.
2. Stop the engine, remove the key, and wait for all moving parts to stop before leaving the operating position.
3. Close fuel shut-off valve at the fuel tank (Figure 31).
4. Squeeze the ends of the hose clamps together and slide them away from the filter (Figure 32).

5. Remove the filter from the fuel lines.
6. Install a new filter and move the hose clamps close to the filter.
7. Open fuel shut-off valve at fuel tank (Figure 31).
8. Check for fuel leaks and repair if needed.
9. Wipe up any spilled fuel.

Drive System Maintenance

Perform the following linkage adjustments when the machine needs maintenance. Perform steps Adjust the Speed Control Linkage through Adjusting the Tracking. If an adjustment is needed, do them in the order that they are listed.

Adjusting the Speed Control Linkage

1. Disengage the PTO and set the parking brake.
2. Stop the engine and wait for all moving parts to stop before leaving the operating position.
3. Move the speed control lever (located on the console) to the full forward position.
4. Check the orientation of the tabs on the ends of the speed control crank. These tabs should be pointing straight down at the 6 o'clock position approximately (Figure 33).

- Adjust the threaded yoke at the bottom of the speed control linkage until the tabs are at the 6 o'clock position (Figure 33).

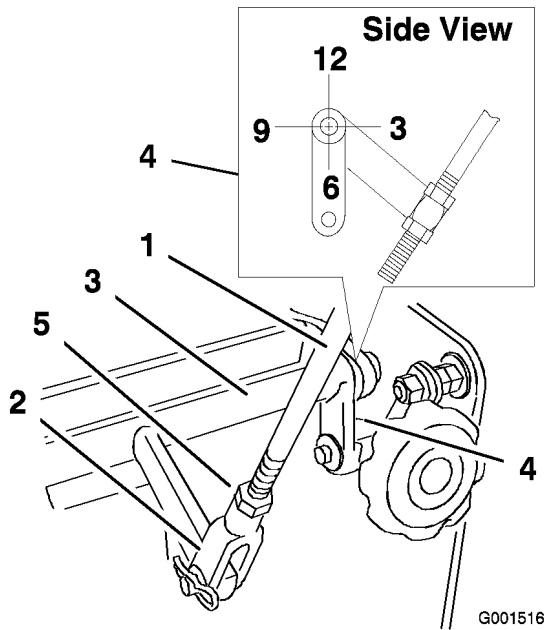

Figure 33

- | | |
|------------------------|-----------------------------|
| 1. Speed control rod | 4. Tabs, 6 o'clock position |
| 2. Yoke | 5. Jam nut |
| 3. Speed control crank | |

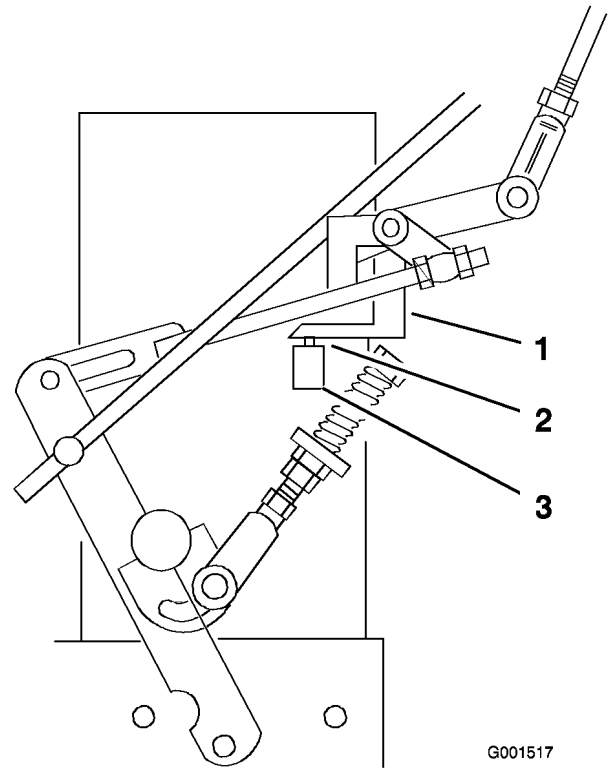

Figure 34

- | | |
|---------------------------|------------------|
| 1. Actuating tab | 3. Safety switch |
| 2. 5/16 inch (8 mm) space | |

- Pull the speed control lever back to neutral.
- Check to make sure the safety switch is depressed and there is a 5/16 inch (8 mm) space between the actuating tab and the switch. (Figure 34).
- If needed, adjust switch location to create the 5/16 inch (8 mm) space (Figure 34).

Adjusting the Neutral Control Linkages



Engine must be running so control linkage adjustments can be performed. Contact with moving parts or hot surfaces may cause personal injury.

Keep hands, feet, face, clothing and other body parts away from rotating parts, muffler and other hot surfaces.



Mechanical or hydraulic jacks may fail to support machine and cause a serious injury.

- Use jack stands when supporting machine.
- Do not use hydraulic jacks.

- Disengage the PTO and set the parking brake.

2. Stop the engine and wait for all moving parts to stop before leaving the operating position.
3. Raise the rear of the machine onto jack stands to raise the drive wheels off the ground.
4. Disengage the parking brake.
5. Start the engine and move the throttle ahead to the full throttle position.
6. Place the neutral locks in the full forward position and move the speed control lever to the medium speed position.
7. Hold OPC levers down.

Note: The OPC levers must be held down whenever the speed control lever is out of the neutral position or the engine will kill.



Electrical system will not perform proper safety shut off with Operator Presence Control (OPC) levers held down in place.

- **Make sure Operator Presence Control (OPC) levers are working when adjustment is completed.**
- **Never operate this unit with Operator Presence Control (OPC) levers held down in place.**

8. Squeeze one drive lever until an increased resistance is felt. This is where neutral should be.

Note: Make sure you have not reached the end of the neutral lock slot. If you have, shorten the control lever linkage. Refer to Adjusting the Control Rod.
9. If the wheel turns while holding the drive lever in neutral, the neutral control linkages need to be adjusted (Figure 35). If wheel stops then go to step 12.
10. Loosen the nut against the neutral control linkage yoke (Figure 35).
11. Adjust the neutral control linkage until the respective drive wheel stops while the drive lever is pulled against the neutral spring (neutral position) (Figure 35).
12. Turn the adjusting bolt approximately 1/4 turn clockwise if the wheel is turning in reverse or turn the bolt approximately 1/4

turn counter-clockwise if the wheel is turning forward (Figure 35).

13. Release the drive lever to the forward drive position and squeeze back into the neutral position. Check to see if the wheel stops. If not, repeat the above adjustment procedure.
14. After adjustments are made, tighten the nuts against the yokes.
15. Repeat this procedure for the opposite side.

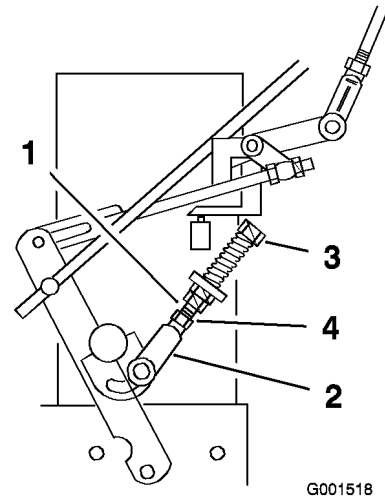



Figure 35

- | | |
|----------------------------|-------------------|
| 1. Neutral control linkage | 3. Adjusting bolt |
| 2. Yoke | 4. Nut |

Adjusting the Hydro Control Linkages



Engine must be running so control linkage adjustments can be performed. Contact with moving parts or hot surfaces may cause personal injury.

Keep hands, feet, face, clothing and other body parts away from rotating parts, muffler and other hot surfaces.



Mechanical or hydraulic jacks may fail to support machine and cause a serious injury.

- **Use jack stands when supporting machine.**
- **Do not use hydraulic jacks.**

Adjusting the Left Side Linkage

1. Disengage the PTO and set the parking brake.
2. Stop the engine and wait for all moving parts to stop before leaving the operating position.
3. Raise the rear of the machine onto jack stands high enough to raise the drive wheels off of the ground.
4. Disengage the parking brake.
5. Start the engine and move the throttle ahead to the full throttle position.
6. Place the left drive lever in the full forward position.
7. Place the speed control lever in the neutral position.



Electrical system will not perform proper safety shut off with Operator Presence Control (OPC) levers held in place.

- **Make sure Operator Presence Control (OPC) levers are working when adjustment is completed.**
- **Never operate this unit with Operator Presence Control (OPC) levers held in place.**

8. Loosen the front adjusting nut on left hydro control linkage as shown in Figure 37.
9. Turn the left rear adjusting nut counter-clockwise until wheel rotates forward (Figure 37).
10. Turn the rear adjusting nut clockwise 1/4 of a turn at a time. Then move the speed control lever forward and back to neutral. Repeat this until left wheel stops rotating forward (Figure 37).
11. Turn the rear nut an additional 1/2 turn and tighten the front adjusting nut.

Note: Make sure flat part of linkage is perpendicular to pin part of swivel.

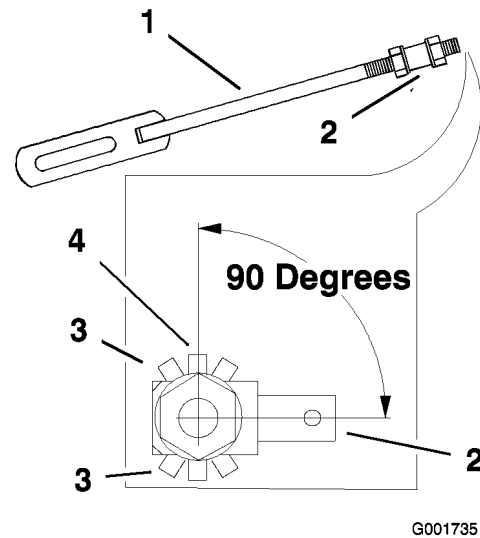

Figure 36

12. After adjusting the left hydro control linkage, move the speed control lever forward and then back to the neutral position.
13. Hold the OPC levers down.

Note: The OPC levers must be held down whenever the speed control lever is out of the neutral position or the engine will kill.
14. Make sure the speed control lever is in the neutral position and the tire does not rotate.
15. Repeat the adjustment if needed.

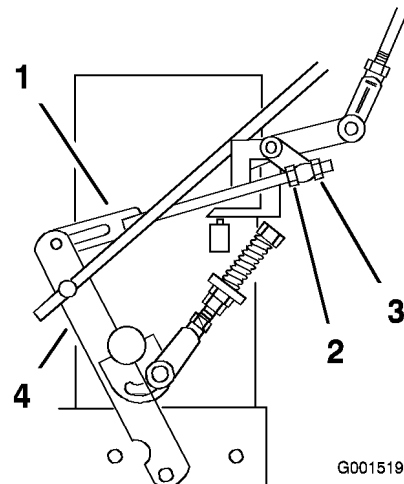

Figure 37

- | | |
|--------------------------|-----------------------|
| 1. Hydro control linkage | 3. Rear adjusting nut |
| 2. Front adjusting nut | 4. Control arm |

Note: If inconsistent neutral occurs, check to be sure both springs are properly tightened on the speed control lever under the console, especially the rear pivot spring. Repeat above adjustments if necessary (Figure 38).

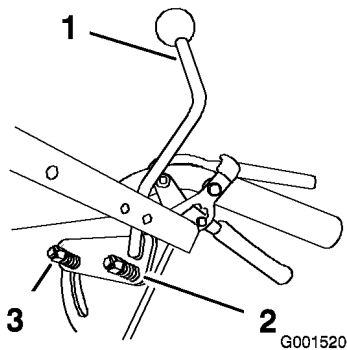

Figure 38

- | | |
|------------------------|-----------|
| 1. Speed control lever | 3. spring |
| 2. Rear pivot spring | |

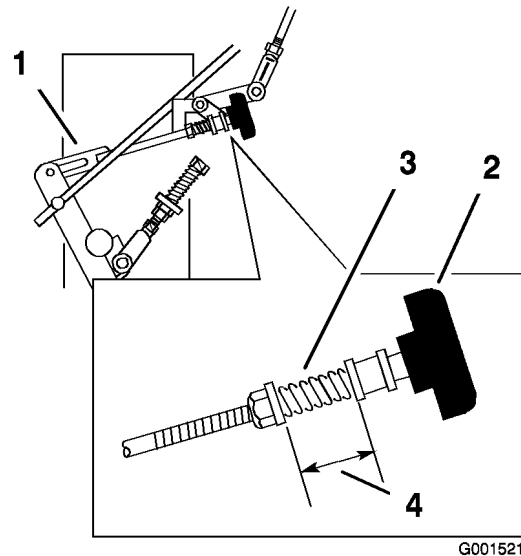

Figure 39

- | | |
|--------------------------|-------------------|
| 1. Hydro control linkage | 3. Spring |
| 2. Quick track knob | 4. 1 inch (26 mm) |

Adjusting the Right Side Linkage

1. Place the speed control lever in the neutral position.
2. Place the right drive lever in the full forward position.
3. Adjust the right side linkage by turning the quick track knob counterclockwise until the tire begins to rotate forward (Figure 39).
4. Turn the knob clockwise 1/4 of a turn at a time. Then move the speed control forward and back to neutral. Repeat this until right wheel stops rotating forward (Figure 39).
5. Hold the OPC levers down.

Note: The OPC levers must be held down whenever the speed control lever is out of the neutral position or the engine will kill.

6. The spring that keeps tension on the knob should normally not need adjustment. However if an adjustment is needed, adjust the length of spring to 1 inch (26 mm) between the washers (Figure 39).
7. Adjust spring length by turning nut at front of spring (Figure 39).

Adjusting the Control Rod

Checking the Control Rod

1. With rear of machine still on jack stands and engine running at full throttle, move the speed control lever to the medium speed position.

Note: The OPC levers must be held down whenever the speed control lever is out of the neutral position or the engine will kill.
2. Move the respective drive lever upward until it reaches the neutral position and engage neutral locks.
3. If the tire rotates in either direction, the length of the control rod will need to be adjusted.

Adjusting the Control Rod

1. Adjust the rod length by releasing the drive lever and removing the hairpin cotter pin and clevis pin. Rotate the rod in the rod fitting (Figure 40).
2. Lengthen the control rod if the tire is turning in reverse and shorten the rod if the tire is turning forward.
3. Rotate the rod several turns if the tire is rotating fast. Then, adjust the rod in 1/2 turn increments.
4. Place the clevis pin into the drive lever (Figure 40).

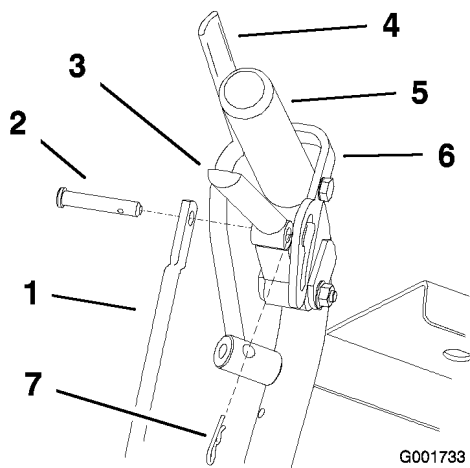

Figure 40

- | | |
|--|-----------------------|
| 1. Control rod | 5. Left handle shown |
| 2. Clevis pin | 6. Neutral lock |
| 3. Drive lever | 7. Hairpin cotter pin |
| 4. Operator Presence Control lever (OPC) | |

5. Release and engage neutral lock checking that the tire does not rotate (Figure 41). Continue this process until the tire does not rotate.
6. Install the hairpin cotter pin between the drive levers and the neutral locks and into the clevis pins (Figure 40).
7. Repeat this adjustment for the opposite side.

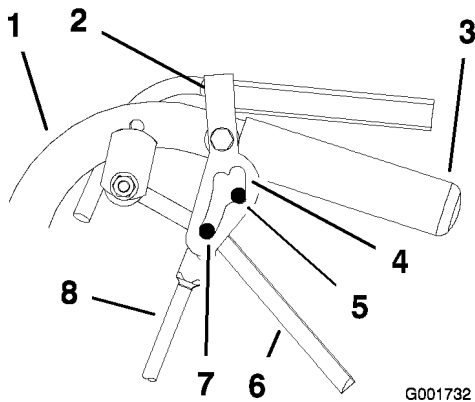

Figure 41

- | | |
|----------------------|-----------------------|
| 1. Handle | 5. Neutral position |
| 2. Neutral lock | 6. Drive lever |
| 3. Handle | 7. Full speed forward |
| 4. Neutral lock slot | 8. Control rod |

Adjusting the Tracking

1. Remove machine from any jack stands.
2. Check the rear tire pressure. Refer to Checking the Tire Pressure.

3. Run the unit and observe the tracking on a level, smooth, hard surface such as concrete or asphalt.
4. If the unit tracks to one side or the other, turn the quick track knob. Turn the knob right to steer right and turn the knob left to steer left (Figure 42).

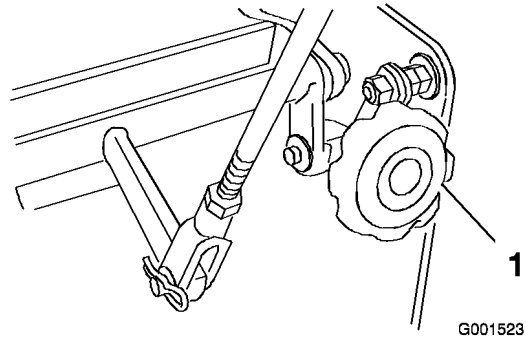

Figure 42

1. Quick track knob

Adjusting the Spring Anchor Links

For medium or heavy duty drive conditions, such as operating with a sulky on steep slopes, a higher spring force may be required on the hydro pump control arms to prevent the drive system from stalling.

1. Disengage the PTO and set the parking brake.
2. Stop the engine and wait for all moving parts to stop before leaving the operating position.
3. For a heavier drive setting, relocate the spring anchor links to either the medium or heavy duty positions (Figure 43). The spring anchor links are attached to the upper rear corner of the hydro drive shields on the left and right sides of the machine.

Note: In the medium or heavy duty positions, the drive lever forces at the upper handle will also be increased

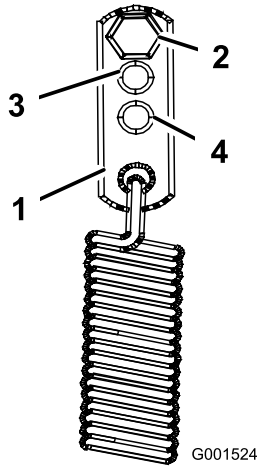

Figure 43

- | | |
|---------------------|-----------------------|
| 1. Spring anchor | 3. Medium setting |
| 2. Standard setting | 4. Heavy duty setting |

Checking the Tire Pressure

Maintain the air pressure in the front and rear tires as specified. Check the pressure at the valve stem after every 50 operating hours or monthly, whichever occurs first (Figure 44).

Rear Tire Pressure: 15 psi (103 kPa)

Caster Tire Pressure: 25-30 psi (172-207 kPa)

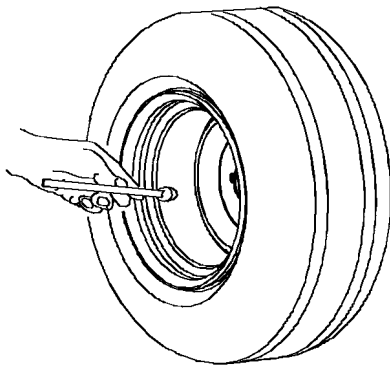

G001055

Figure 44

- | | |
|--------------|----------------|
| 1. Rear Tire | 2. Caster tire |
|--------------|----------------|

Cooling System Maintenance

Cleaning the Air Intake Screen

Before each use remove any build-up of grass, dirt or other debris from the cylinder and cylinder head cooling fins, air intake screen on flywheel end, and carburetor-governor levers and linkage. This will help insure adequate cooling and correct engine speed and will reduce the possibility of overheating and mechanical damage to the engine.

Cleaning the Cooling System

Clean the air intake screen from grass and debris before each use.

Check and clean cooling fins and engine shrouds every 100 hours or yearly, whichever ever comes first.

1. Disengage the PTO and set the parking brake.
2. Stop the engine, remove the key, and wait for all moving parts to stop before leaving the operating position.
3. Remove the air intake screen, recoil starter and fan housing (Figure 45).
4. Clean the debris and grass from the engine parts.
5. Install air intake screen, recoil starter and fan housing (Figure 45).

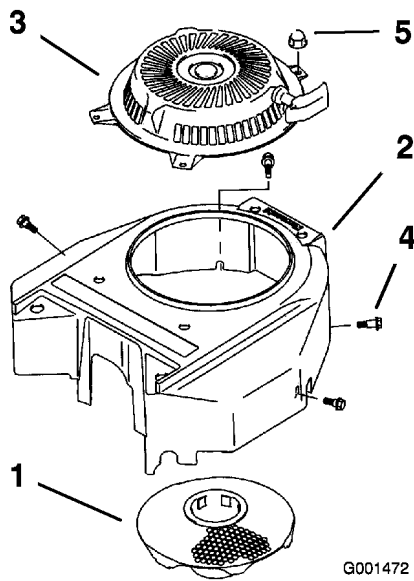

Figure 45

- | | |
|----------------------|---------|
| 1. Air intake screen | 4. Bolt |
| 2. Fan housing | 5. Nut |
| 3. Recoil starter | |

2. Release the parking brake; refer to Releasing the Parking Brake.
3. Remove the spring hair pin from the lower brake link (Figure 46).

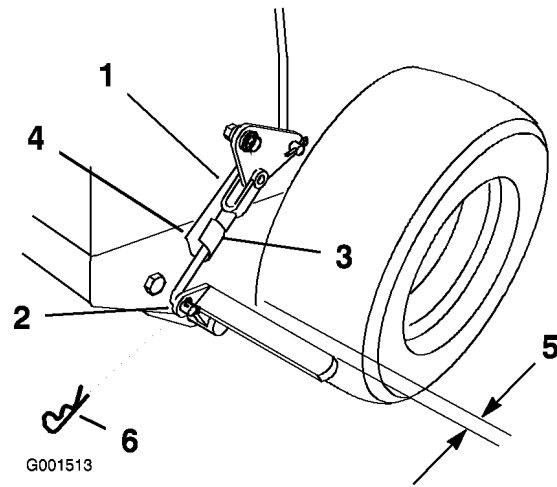

Figure 46

- | | |
|-----------------------|---------------------|
| 1. Brake linkage yoke | 4. Lower brake link |
| 2. Lower brake lever | 5. 1/4 inch (6 mm) |
| 3. Spring clevis pin | 6. Hair pin |

Brake Maintenance

Servicing the Brake

Before each use, check the parking brake for proper operation.

Always set the parking brake when you stop the machine or leave it unattended. If the parking brake does not hold securely, adjust it.

Checking the Parking Brake

1. Move the machine onto a level surface.
2. Disengage the power take off (PTO) and stop the engine.
3. Set the parking brake.

Note: Setting the parking brake should take a reasonable amount of force. If it engages too hard or too easily, an adjustment is required. Refer to Adjusting the Parking Brake.

Adjusting the Parking Brake

The parking brake lever is on the right side of the machine (Figure 43). If the parking brake does not hold securely, adjust it.

1. Check the parking brake before you adjust it; refer to Checking the Parking Brake.

4. Rotate the lower brake link yoke clockwise into the yoke to tighten the parking brake; rotate the brake link yoke counterclockwise out of the yoke out to loosen the parking brake (Figure 46).

Note: There should be approximately 1/4 inch clearance between the tire and the flat bar when the parking brake in the released position (Figure 46).

5. Secure the lower link to the lower brake lever with the hair pin cotter and the clevis pin (Figure 46).
6. Check the brake operation again; refer to Checking the Parking Brake.

Belt Maintenance

Checking the Belts

Check all belts after every 50 operating hours or monthly, whichever occurs first.

Look for dirt, wear, cracks and signs of overheating.

Replacing the Mower Belt

1. Disengage the blade control (PTO) lever and set the parking brakes.
2. Stop the engine and wait for all moving parts to stop before leaving the operating position.
3. Remove the knobs and the belt cover on the mower.
4. Remove the idler pulley and the worn belt (Figure 47).
5. Install the new mower belt.
6. Install the idler pulley.
7. Engage the blade control (PTO) lever and check the belt tension. Refer to Adjusting the Mower Belt Tension.

Note: The proper mower belt tension is 10-15 lbf. (44-67 N) with the belt deflected 1/2 inch (13 mm) halfway between the pulleys (Figure 47).

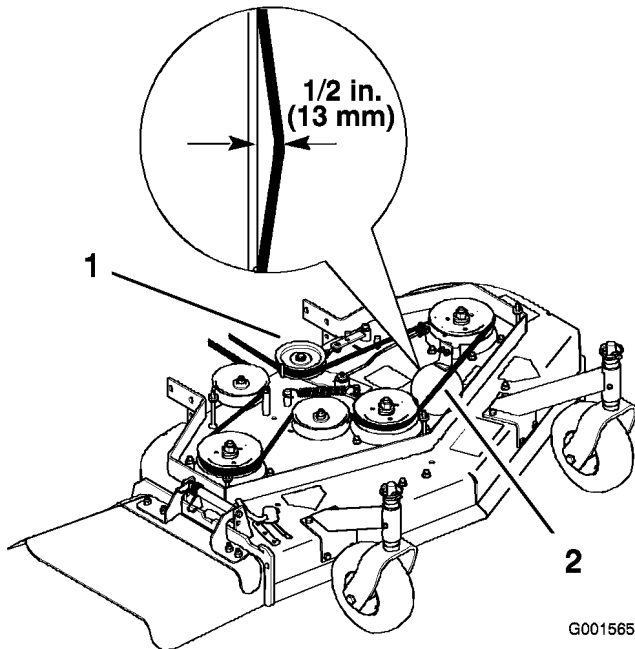

Figure 47

1. Mower belt with 1/2 inch (13mm) deflection 2. Idler pulley

Adjusting the Mower Belt Tension

Adjusting the Tension

Adjust the mower belt tension as follows:

- After the first 8 operating hours.
- After the first 25 operating hours.
- After every 50 operating hours.

Check the belt tension after the first 8 operating hours and 25 operating hours thereafter. Check the belt tension after every 50 operating hours.

Important: The brake needs to be adjusted when the belt tension or the brake linkage is adjusted.

Important: The belt must be tight enough to not slip during heavy loads while cutting grass. Over tensioning the belt will reduce the spindle bearing life, the belt life and the idler pulley life.

The belt must be tight enough so it does not slip during heavy loads while cutting grass and over-tensioning will reduce belt and spindle bearing life.

1. Disengage the blade control (PTO) lever and set the parking brakes.
2. Stop the engine and wait for all moving parts to stop before leaving the operating position.
3. Loosen the locknut on the turnbuckle (Figure 48).
4. Rotate the turnbuckle toward the rear of the mower to increase the tension on the belt. Rotate the turnbuckle toward the front of the mower to decrease the tension on the belt (Figure 48).

Note: The eyebolt threads on both ends of the turnbuckle should be engaged a minimum of 5/16 inch (8 mm).

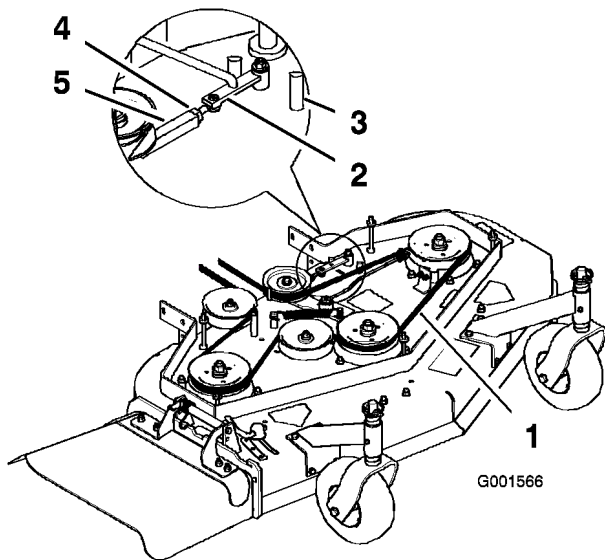

Figure 48

- | | |
|--|---------------|
| 1. 1/2 inch (13 mm)
deflection here | 4. Locknut |
| 2. Assist arm | 5. Turnbuckle |
| 3. Front stop | |

5. Engage the bladed control lever (PTO) and check the belt tension.
6. If there is no adjustment left in the turnbuckle and the belt is still loose, the rear idler pulley needs to be positioned to the middle or front hole (Figure 49). Use the hole that will give the correct adjustment.
7. When the idler pulley is moved the belt guide must be moved. Move the belt guide to the front position (Figure 49).

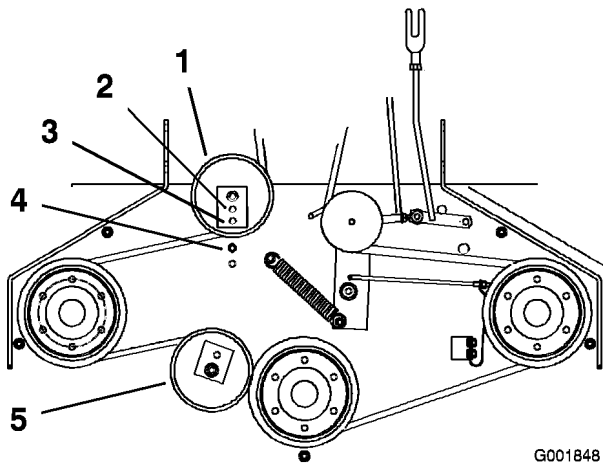

Figure 49

- | | |
|----------------------|--------------------------------|
| 1. Rear idler pulley | 4. Belt guide in back position |
| 2. Middle hole | 5. Front idler pulley |
| 3. Front hole | |

8. Check the belt guide under the engine frame for proper adjustment (Figure 50).

Note: The distance between the belt guide and the mower belt should be 3/4 inch (19 mm) when you engage the mower belt (Figure 50). Adjust the mower belt as necessary. The disengaged belt should not drag or fall off the pulley when the guides are properly adjusted.

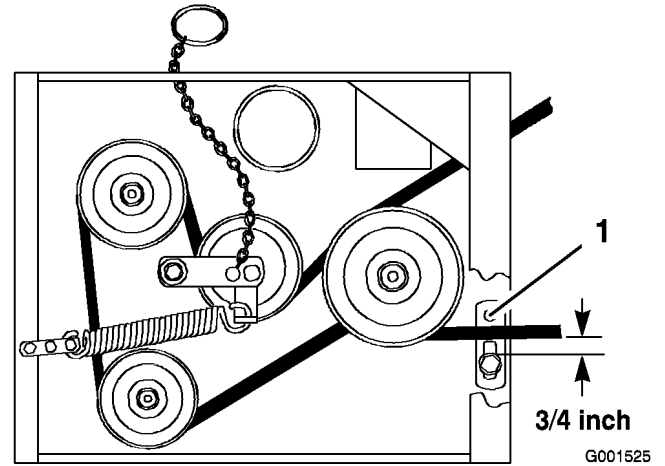

Figure 50

1. Belt guide

9. Check the blade brake adjustment; refer to Adjusting the Blade Brake.

Adjusting the PTO Engagement Linkage

The PTO engagement linkage adjustment is located beneath the front left hand corner of the engine deck.

1. Disengage the blade control (PTO) lever and set the parking brakes.
2. Stop the engine and wait for all moving parts to stop before leaving the operating position.
3. Engage the blade control lever (PTO).
4. Adjust the linkage length to where the lower end of the bellcrank just clears the axle support gusset (Figure 51).

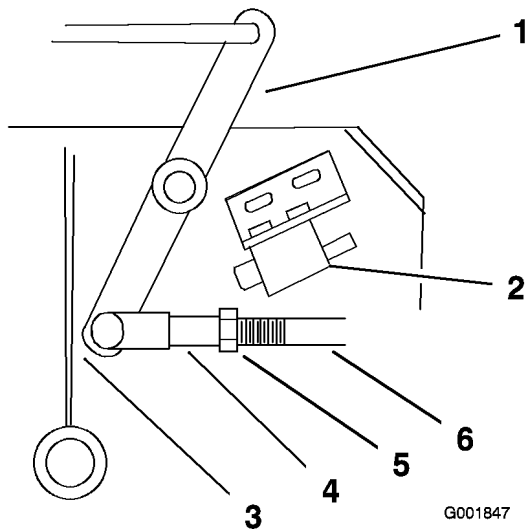

Figure 51

- | | |
|--|--------------------|
| 1. Bellcrank | 4. Yoke |
| 2. Safety switch located under engine deck | 5. Nut |
| 3. Bellcrank just clears the gusset with the PTO engaged | 6. Assist arm link |

5. Make sure the assist arm is against the rear assist arm stop on the deck (Figure 52).
6. Push the blade control lever (PTO) down to the disengaged position.
7. The assist arm should contact the front assist arm stop. If it does not contact, adjust the bellcrank so it is closer to the gusset (Figure 52).

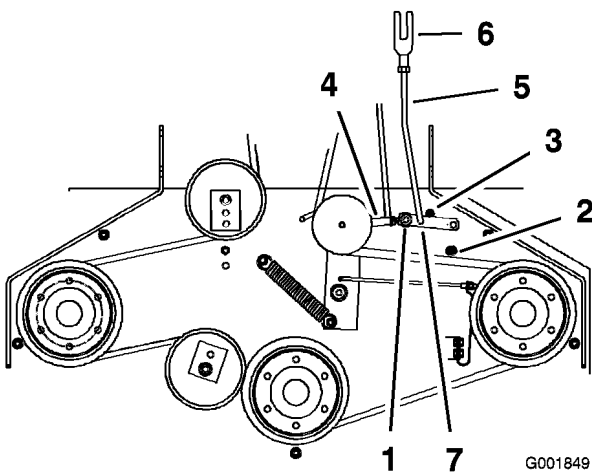

Figure 52

- | | |
|--------------------------|-------------------------|
| 1. Assist arm | 3. Rear assist arm stop |
| 2. Front assist arm stop | 4. Turnbuckle |

8. To adjust the assist arm link, remove the hairpin cotter pin from the assist arm (Figure 52).
9. Loosen the nut against the yoke (Figure 51).
10. Remove the assist arm link from the assist arm and rotate the link to adjust the length.
11. Install the assist arm link into the assist arm and secure it with the hairpin cotter pin (Figure 52).
12. Check if the assist arm hits against the stops correctly.

Adjusting the PTO Safety Switch

1. Disengage the blade control (PTO) lever and set the parking brakes.
2. Stop the engine and wait for all moving parts to stop before leaving the operating position.
3. Disengage the blade control lever (PTO). Make sure the assist arm is against the front assist stop arm.
4. If needed, adjust the blade safety switch by loosening the bolts holding the switch bracket (Figure 53).
5. Move the mounting bracket until the bellcrank depresses the plunger by a 1/4 inch (6 mm).
- 6.

Note: Make sure the bellcrank does not touch the switch body or damage to the switch could occur (Figure 53). Tighten the switch mounting bracket.

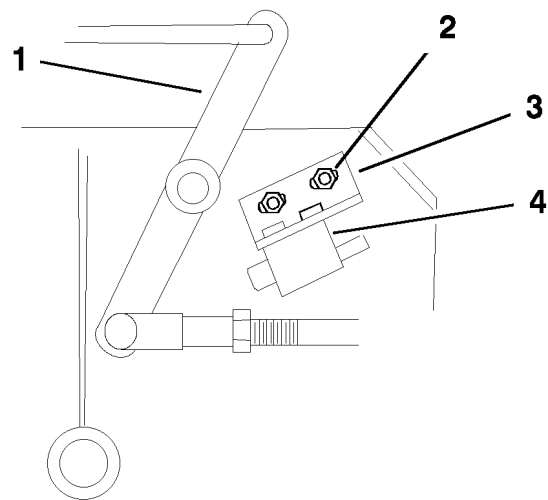

Figure 53

- | | |
|-------------------|----------------------------|
| 1. Bellcrank | 3. Switch mounting bracket |
| 2. Bolts and nuts | 4. Switch body |

Hydraulic System Maintenance

Servicing the Hydraulic System

Checking the Hydraulic Fluid

Check the hydraulic fluid level as follows:

- Check the hydraulic fluid level before engine is first started.
- Check the hydraulic fluid level after first 8 operating hours.
- Check the hydraulic fluid level after every 25 operating hours.

Fluid Type: Mobil 1 15W-50 synthetic motor oil or equivalent synthetic oil.

Important: Use oil specified or equivalent. Other fluids could cause system damage.

Hydraulic System Oil Capacity: 77 oz. (2.3 l)

Note: There are two ways of checking the hydraulic oil. One is when the oil is warm and one is when the oil is cold. The baffle inside the tank has two levels depending if the oil is warm or cold.

1. Position machine on a level surface.
2. Disengage the power take off (PTO) and shut off the engine.
3. Wait for all moving parts to stop before leaving the operating position and then set the parking brake.
4. Clean area around cap and filler neck of hydraulic tank (Figure 54).

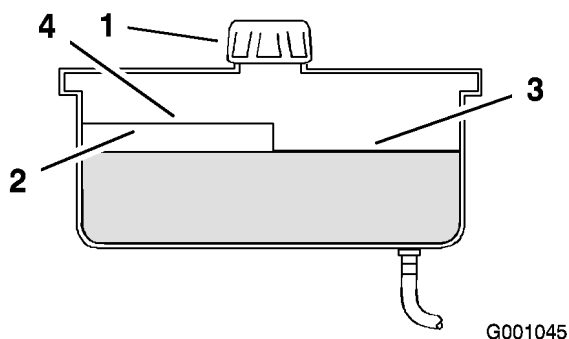



Figure 54

1. Cap
2. Baffle
3. Cold fluid level-full
4. Hot fluid level-full

5. Remove cap from filler neck. Look inside to check if there is fluid in the reservoir. (Figure 54).
 6. If there is no fluid, add fluid to the reservoir until it reaches the cold level of the baffle.
 7. Run the machine at low idle for 15 minutes to allow any air to purge out of the system and warm fluid. Refer to Starting and Stopping the Engine.
 8. Recheck the fluid level while the fluid is warm. If required, add fluid to the reservoir until it reaches the hot level of the baffle.
- Note:** The fluid level should be to the top of the hot level of the baffle, when the fluid is warm (Figure 54).
9. Install cap on filler neck.



Hydraulic fluid escaping under pressure can penetrate skin and cause injury.

- **If hydraulic fluid is injected into the skin it must be surgically removed within a few hours by a doctor familiar with this type of injury. Gangrene may result if this is not done.**
- **Keep body and hands away from pin hole leaks or nozzles that eject high pressure hydraulic fluid.**
- **Use cardboard or paper to find hydraulic leaks.**
- **Safely relieve all pressure in the hydraulic system before performing any work on the hydraulic system.**
- **Make sure all hydraulic fluid hoses and lines are in good condition and all hydraulic connections and fittings are tight before applying pressure to hydraulic system.**

Replacing the Hydraulic Filter

Change the hydraulic filter as follows:

- After the first 8 operating hours.
 - After every 200 operating hours.
1. Disengage the PTO and set the parking brake.

2. Stop the engine and wait for all moving parts to stop before leaving the operating position.

Important: Do not substitute automotive oil filter or severe hydraulic system damage may result.

3. Remove hydraulic reservoir cap and temporarily cover opening with a plastic bag and rubber band to prevent all hydro fluid from draining out.
4. Locate filter under engine base and place drain pan under filter (Figure 55).
5. Remove the old filter and wipe the filter adapter gasket surface clean (Figure 55).

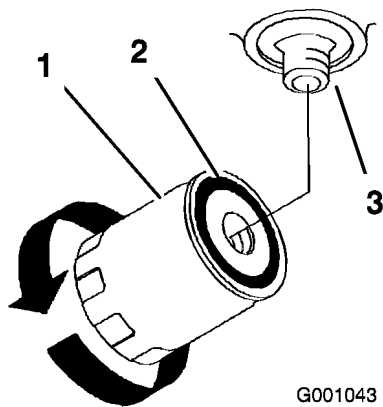

Figure 55

- | | |
|---------------------|------------|
| 1. Hydraulic filter | 3. Adapter |
| 2. Gasket | |

6. Apply a thin coat hydro fluid to the rubber gasket on the replacement filter.
7. Install replacement hydraulic filter onto the filter adapter. Do not tighten.
8. Remove plastic bag from reservoir opening and allow filter to fill with hydraulic fluid.
9. When the hydraulic filter is full, turn the oil filter clockwise until the rubber gasket contacts the filter adapter, then tighten the filter an additional 1/2 turn (Figure 55).
10. Clean up any spilled fluid.
11. If there is no fluid, add Mobil 1 15W-50 synthetic motor oil or equivalent synthetic oil to approximately 1/4 inch (6 mm) below the top of reservoir baffle.

Important: Use oil specified or equivalent. Other fluids could cause system damage.

12. Start engine and let run for about two minutes to purge air from the system. Stop the engine and check for leaks. If one or both wheels will not drive, refer to Bleeding Hydraulic System.
13. Recheck level and add fluid, if required. Do not overfill.

Bleeding the Hydraulic System

The traction system is self bleeding, however, it may be necessary to bleed the system if fluid is changed or after work is performed on the system.

Air must be purged from the hydraulic system when any hydraulic components, including oil filter, are removed or any of the hydraulic lines are disconnected. The critical area for purging air from the hydraulic system is between the oil reservoir and each charge pump located on the top of each variable displacement pump. Air in other parts of the hydraulic system will be purged through normal operation once the charge pump is primed.

1. Disengage the PTO and set the parking brake.
2. Stop the engine and wait for all moving parts to stop before leaving the operating position.
3. Raise the rear of the machine up onto jack stands high enough to raise the drive wheels off the ground.
4. Check the hydraulic fluid level.
5. Start the engine and move the throttle control to the full throttle position. Move the speed control lever to the middle speed position and place the drive levers into the drive position.

If either drive wheel does not rotate, it is possible to assist the purging of the charge pump by carefully rotating the tire in the forward direction.

Note: It is necessary to lightly touch the charge pump cap with your hand to check the pump temperature. If the cap is too hot to touch, turn off engine. The pumps may be damaged if the pump becomes too hot. If either drive wheel still does not rotate continue to next step.

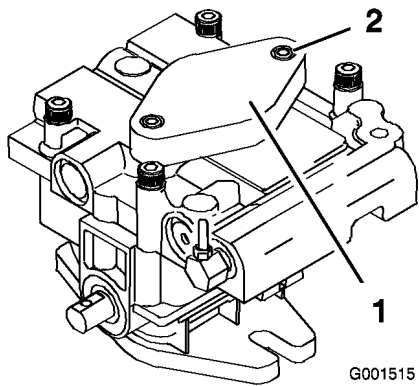

Figure 56

1. Charge pump cap 2. Socket head screw

6. Thoroughly clean the area around each of the charge pump housings.
7. To prime the charge pump, loosen two hex socket head capscrews (Figure 56) 1-1/2 turns only. Make sure engine is not running. Lift charge pump housing upward and wait for a steady flow of oil to flow out from under housing. Retighten capscrews. Do this for both pumps.

Note: Hydraulic reservoir can be pressurized to up to 5 psi to speed this process.

8. If either drive wheel still does not rotate, stop and repeat steps 4 and 5 on the respective pump. If wheels rotate slowly, the system may prime after additional running. Recheck hydraulic fluid level.
9. Allow unit to run several minutes after the charge pumps are primed with drive system in the full speed position.
10. Check the hydro control linkage adjustment. Refer to Adjusting the Hydro Control Linkages.

Checking the Hydraulic Lines

After every 100 operating hours, check hydraulic lines and hoses for leaks, loose fittings, kinked lines, loose mounting supports, wear, weather and chemical deterioration. Make necessary repairs before operating.

Note: Keep areas around hydraulic system clean from grass and debris build up.



Hydraulic fluid escaping under pressure can penetrate skin and cause injury.

- If hydraulic fluid is injected into the skin it must be surgically removed within a few hours by a doctor familiar with this type of injury. Gangrene may result if this is not done.
- Keep body and hands away from pin hole leaks or nozzles that eject high pressure hydraulic fluid.
- Use cardboard or paper to find hydraulic leaks.
- Safely relieve all pressure in the hydraulic system before performing any work on the hydraulic system.
- Make sure all hydraulic fluid hoses and lines are in good condition and all hydraulic connections and fittings are tight before applying pressure to hydraulic system.

Mower Deck Maintenance

Servicing the Cutting Blades

To ensure a superior quality of cut, keep the blades sharp. For convenient sharpening and replacement, you may want to keep extra blades on hand.



A worn or damaged blade can break, and a piece of the blade could be thrown into the operator's or bystander's area, resulting in serious personal injury or death.

- Inspect the blade periodically for wear or damage.
- Replace a worn or damaged blade.

Before Inspecting or Servicing the Blades

Park the machine on a level surface, disengage the blade control bail and set the parking brake. Turn the ignition key to off. Remove the key and disconnect the spark plug wire(s) from the spark plug(s).

Inspecting the Blades

Inspect the blades every 8 hours.

1. Inspect the cutting edges (Figure 57). If the edges are not sharp or have nicks, remove and sharpen the blades. Refer to Sharpening the Blades.

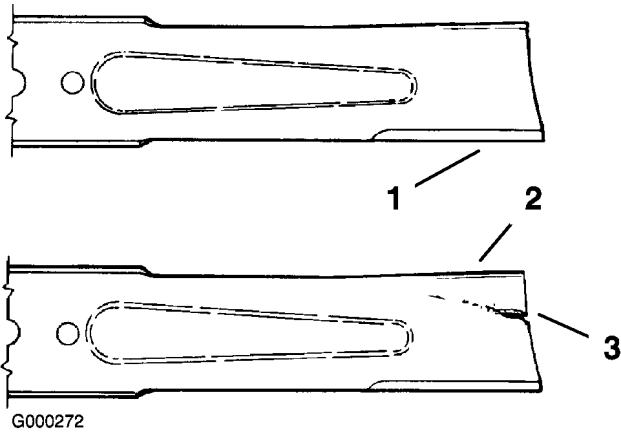

Figure 57

1. Cutting Edge
2. Curved Area
3. Wear/slot Forming

2. Inspect the blades, especially the curved area (Figure 57). If you notice any damage, wear, or a slot forming in this area (item 3 in Figure 57), immediately install a new blade.

Checking for Bent Blades

1. Rotate the blades until the ends face forward and backward (Figure 58).

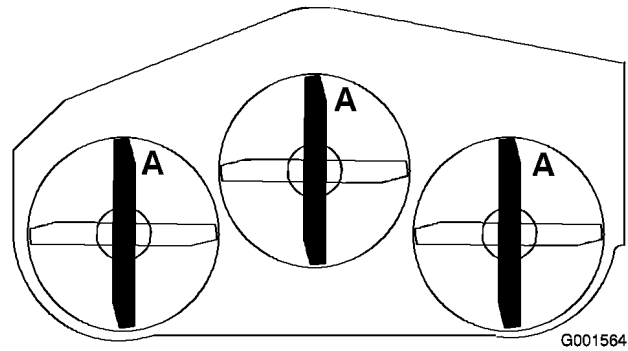

Figure 58

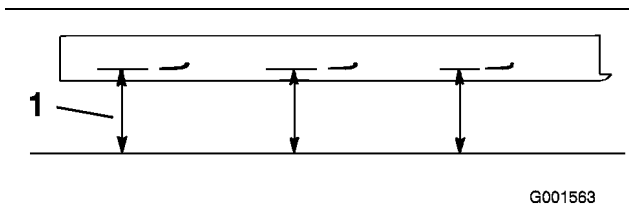

Figure 59

1. Measure from cutting edge to a level surface
2. Measure from a level surface to the cutting edge, position A, of the blades (Figure 59). Note this dimension.
3. Rotate the opposite ends of the blades forward.
4. Measure from a level surface to the cutting edge of the blades at the same position as in step 1. The difference between the dimensions obtained in steps 1 and 2 must not exceed 1/8 inch (3 mm). If this dimension exceeds 1/8 inch (3 mm), the blade is bent and must be replaced. Refer to Removing the Blades and Installing the Blades.



A blade that is bent or damaged could break apart and could seriously injure or kill you or bystanders.

- Always replace bent or damaged blade with a new blade.
- Never file or create sharp notches in the edges or surfaces of blade.

Removing the Blades

Replace the blades if you hit a solid object or if the blades are out of balance or bent. To ensure optimum performance and continued

safety conformance of the machine, use genuine Toro replacement blades. Replacement blades made by other manufacturers may result in non-conformance with safety standards.

1. Hold the blade bolt with a wrench.
2. Remove the nut, blade bolt, curved washer, blade, spacers, and thin washer from the spindle (Figure 60).

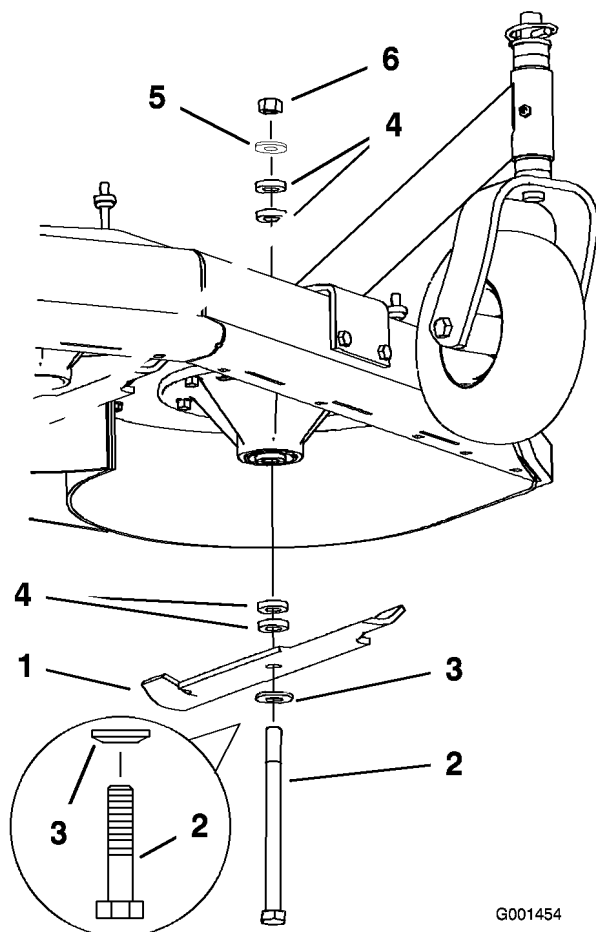

Figure 60

- | | |
|------------------|----------------|
| 1. Blade | 4. Spacer |
| 2. Blade bolt | 5. Thin washer |
| 3. Curved washer | 6. Nut |

Sharpening the Blades

1. Use a file to sharpen the cutting edge at both ends of the blade (Figure 61). Maintain the original angle. The blade retains its balance if the same amount of material is removed from both cutting edges.

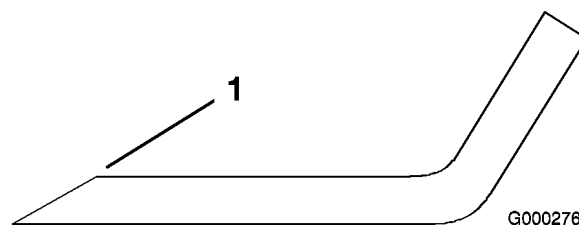

Figure 61

1. Sharpen at original angle

2. Check the balance of the blade by putting it on a blade balancer (Figure 62). If the blade stays in a horizontal position, the blade is balanced and can be used. If the blade is not balanced, file some metal off the end of the sail area only (Figure 62). Repeat this procedure until the blade is balanced.

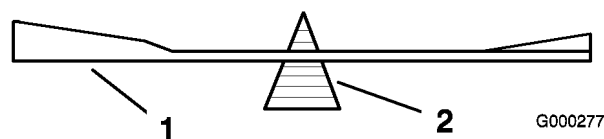

Figure 62

1. Blade
2. Balancer

Installing the Blades

1. Install the bolt, curved washer, and blade. Select the proper number of spacer(s) for the height-of-cut, and slide the bolt into the spindle (Figure 60).

Important: The curved part of the blade must point upward toward the inside of the mower to ensure proper cutting.

2. Install the remaining spacer(s) and secure them with a thin washer and a nut (Figure 60).
3. Torque the blade bolt to 75-80 ft-lb (101-108 N•m).

Adjusting the Blade Brake

1. Disengage the PTO, turn the ignition key to off, and remove the key.
2. Wait for all moving parts to stop before leaving the operating position and then set the parking brakes.
3. If necessary, adjust the spring mounting bolts so that the blade brake pad rubs against both sides of the pulley groove (Figure 63).

- Adjust the nut at the end of the blade brake rod until there is 1/8-3/16 inch (3 mm -5 mm) between the nut and spacer (Figure 63).
- Engage the blades. Ensure the blade brake pad no longer contacts the pulley groove.

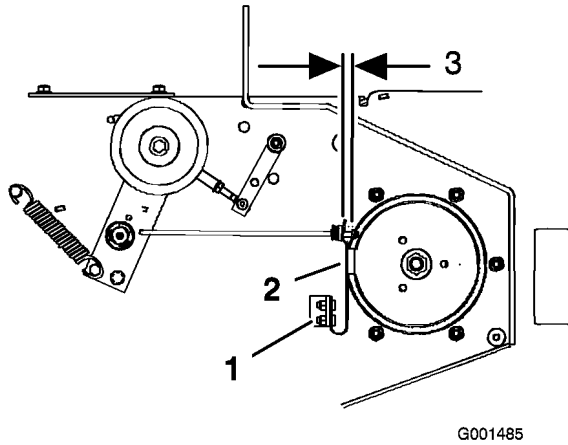

Figure 63

- Spring mounting bolts
- Blade brake pad
- 1/8-3/16 inch (3mm-5mm)

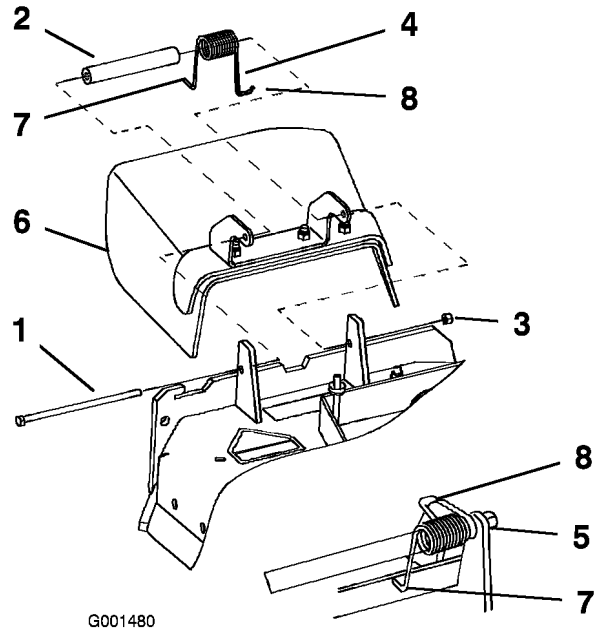

Figure 64

- Bolt
- Spacer
- Locknut
- Spring
- Spring installed
- Grass Deflector
- L end of spring, place behind deck edge before installing bolt
- J hook end of spring

Replacing the Grass Deflector



An uncovered discharge opening could allow the lawn mower to throw objects in the operator's or bystander's direction and result in serious injury or death. Also, contact with the blade could occur.

Never operate the lawn mower with the grass deflector removed unless you install a cover plate, a mulch plate, or a grass chute and catcher.

- Remove the locknut, bolt, spring and spacer holding the deflector to the pivot brackets (Figure 64). Remove damaged or worn grass deflector.

- Place spacer and spring onto grass deflector. Place the L end of spring behind deck edge.

Note: Make sure the L end of spring is installed behind deck edge before installing the bolt as shown in Figure 64.

- Install bolt and nut. Place the J hook end of spring around grass deflector (Figure 64).

Important: The grass deflector must be free to rotate. Lift the deflector up to the full open position and ensure that it rotates freely without binding into the full down position.

Storage

1. Disengage the power take off (PTO), set the parking brake, and turn the ignition key to off. Remove the key.
2. Remove grass clippings, dirt, and grime from the external parts of the entire machine, especially the engine. Clean dirt and chaff from the outside of the engine's cylinder head fins and blower housing.

Important: You can wash the machine with mild detergent and water. Do not pressure wash the machine. Avoid excessive use of water, especially near the shift lever plate, and engine.

3. Check the brake; refer to Servicing the Brake in Brake Maintenance, page 39.
4. Service the air cleaner; refer to Servicing the Air Cleaner.
5. Grease the machine; refer to Greasing and Lubrication in Lubrication, page 27.
6. Change the crankcase oil; refer to Servicing the Engine in.
7. Check the tire pressure; refer to Checking the Tire Pressure in Drive System Maintenance, page 32.
8. For long-term storage:
 - A. Add stabilizer/conditioner additive to fuel in the tank.
 - B. Run engine to distribute conditioned fuel through the fuel system (5 minutes).
 - C. Stop engine, allow to cool and drain the fuel tank; refer to Servicing the Fuel Tank in Fuel System Maintenance, page 31, or operate engine until it stops.
 - D. Restart engine and run until it stops. Repeat, on Choke until engine will not restart.
 - E. Dispose of fuel properly. Recycle as per local codes.

Note: Do not store stabilizer/conditioned gasoline over 90 days.

9. Remove the spark plug(s) and check its condition; refer to Servicing the Spark Plug. With the spark plug(s) removed from the

engine, pour two tablespoons of engine oil into the spark plug hole. Now use the starter to crank the engine and distribute the oil inside the cylinder. Install the spark plug(s). Do not install the wire on the spark plug(s).

10. Check and tighten all bolts, nuts, and screws. Repair or replace any part that is damaged or defective.
11. Paint all scratched or bare metal surfaces. Paint is available from your Authorized Service Dealer.
12. Store the machine in a clean, dry garage or storage area. Remove the key from the ignition switch and keep it in a memorable place. Cover the machine to protect it and keep it clean.

Troubleshooting

Problem	Possible Cause	Corrective Action
Engine will not start, starts hard, or fails to keep running.	<ol style="list-style-type: none"> 1. Fuel tank is empty. 2. Fuel shut off valve is closed. 3. Choke is not on. 4. Air cleaner is dirty. 5. Spark plug wire is loose or disconnected. 6. Spark plug is pitted, fouled, or the gap is incorrect. 7. Dirt in the fuel filter. 8. Dirt, water, or stale fuel is in the fuel system. 	<ol style="list-style-type: none"> 1. Fill fuel tank with gasoline. 2. Open the fuel shut off valve. 3. Move the throttle lever to choke position. 4. Clean or replace the air cleaner element. 5. Install wire on spark plug. 6. Install a new, correctly gapped spark plug. 7. Replace the fuel filter. 8. Contact an Authorized Service Dealer.
Engine loses power.	<ol style="list-style-type: none"> 1. Engine load is excessive. 2. Air cleaner is dirty. 3. Oil level in the crankcase is low. 4. Cooling fins and air passages under the engine blower housing are plugged. 5. Spark plug is pitted, fouled, or the gap is incorrect. 6. Vent hole in the fuel cap is plugged. 7. Dirt in the fuel filter. 8. Dirt, water, or stale fuel is in the fuel system. 	<ol style="list-style-type: none"> 1. Reduce the ground speed. 2. Clean the air cleaner element. 3. Add oil to the crankcase. 4. Remove the obstruction from the cooling fins and air passages. 5. Install a new, correctly gapped spark plug. 6. Clean or replace the fuel cap. 7. Replace the fuel filter. 8. Contact an Authorized Service Dealer.
Engine overheats.	<ol style="list-style-type: none"> 1. Engine load is excessive. 2. Oil level in the crankcase is low. 3. Cooling fins and air passages under the engine blower housing are plugged. 	<ol style="list-style-type: none"> 1. Reduce the ground speed. 2. Add oil to the crankcase. 3. Remove the obstruction from the cooling fins and air passages.

Problem	Possible Cause	Corrective Action
Machine does not drive.	<ol style="list-style-type: none"> 1. Shift lever is in neutral. 2. Traction belt is worn, loose or broken. 3. Traction belt is off a pulley. 4. Broken or missing idler spring. 	<ol style="list-style-type: none"> 1. Move the shift lever to a drive gear position. 2. Change the belt. 3. Change the belt. 4. Replace the spring.
Abnormal vibration.	<ol style="list-style-type: none"> 1. Cutting blade(s) is/are bent or unbalanced. 2. Blade mounting bolt is loose. 3. Engine mounting bolts are loose. 4. Loose engine pulley, idler pulley, or blade pulley. 5. Engine pulley is damaged. 6. Blade spindle is bent. 	<ol style="list-style-type: none"> 1. Install new cutting blade(s). 2. Tighten the blade mounting bolt. 3. Tighten the engine mounting bolts. 4. Tighten the appropriate pulley. 5. Contact an Authorized Service Dealer. 6. Contact an Authorized Service Dealer.
Uneven cutting height.	<ol style="list-style-type: none"> 1. Blade(s) not sharp. 2. Cutting blade(s) is/are bent. 3. Mower is not level. 4. Underside of mower is dirty. 5. Tire pressure is not correct. 6. Blade spindle bent. 	<ol style="list-style-type: none"> 1. Sharpen the blade(s). 2. Install new cutting blade(s). 3. Level the mower from side-to-side and front-to-rear. 4. Clean the underside of the mower. 5. Adjust the tire pressure. 6. Contact an Authorized Service Dealer.
Blades do not rotate.	<ol style="list-style-type: none"> 1. Mower deck belt is worn or loose. 2. Mower deck belt is broken. 3. Mower deck belt is off pulley. 4. Broken or missing idler spring. 	<ol style="list-style-type: none"> 1. Check the belt tension. 2. Install new deck belt. 3. Inspect the belt and replace if damaged. Check the pulleys and idlers and adjust the belt tension. 4. Replace the spring.

Schematics

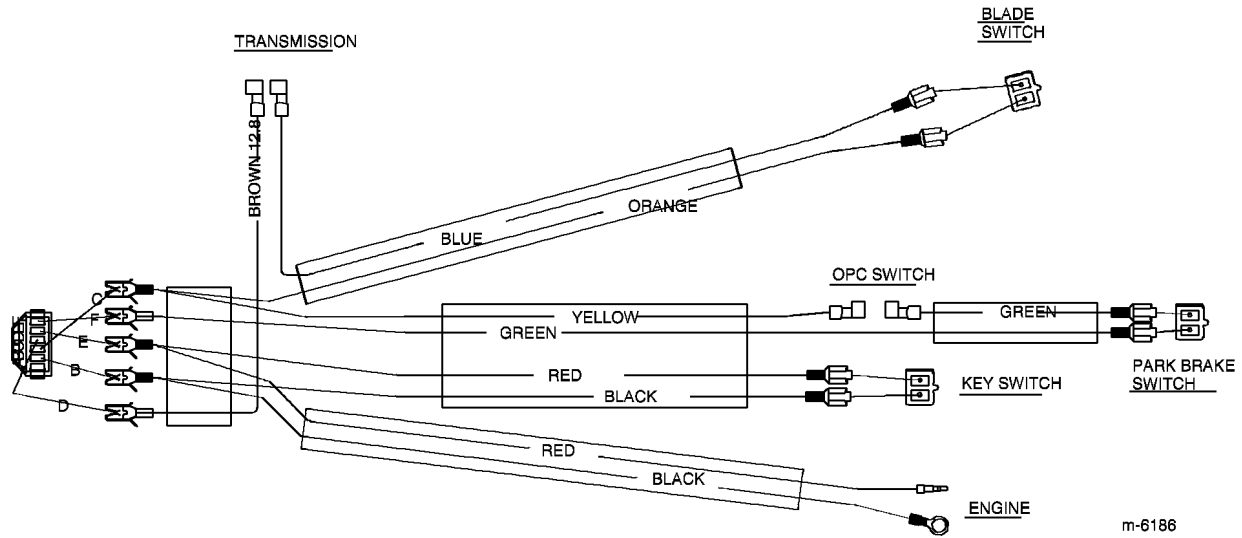

m-6186

Electrical Schematic (Rev. -)

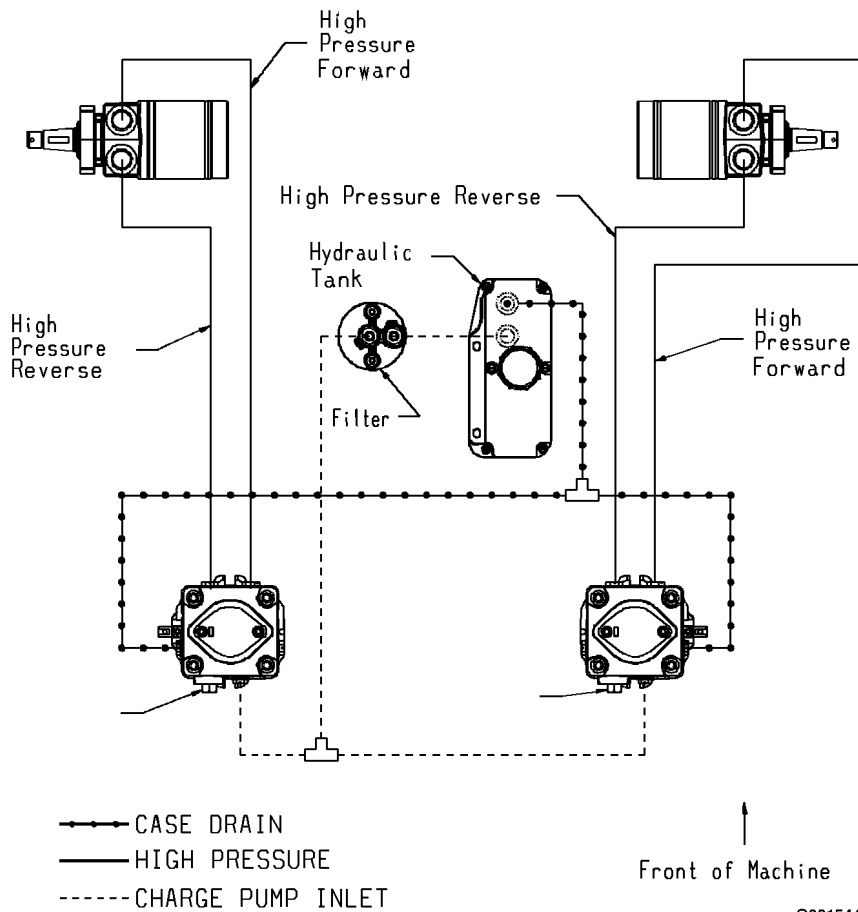

G001544

Hydraulic Schematic (Rev. -)



Evaporative Emission Control Warranty Statement

California Evaporative Emission Control Warranty Statement
Your Warranty Rights and Obligations

Introduction

The California Air Resources Board and The Toro® Company are pleased to explain the evaporative emission control system's warranty on your 2006 model year equipment. In California, new equipment that use small off-road engines must be designed, built, and equipped to meet the State's stringent anti-smog standards. The Toro® Company must warrant the evaporative emission control system on your equipment for two years provided there has been no abuse, neglect or improper maintenance of your equipment. Your evaporative emission control system may include parts such as: fuel lines, fuel line fittings, and clamps.

Manufacturer's Warranty Coverage:

This evaporative emission control system is warranted for two years. If any evaporative emission-related part on your equipment is defective, the part will be repaired or replaced by The Toro® Company.

Owner's Warranty Responsibilities:

- As the equipment owner, you are responsible for performance of the required maintenance listed in your Operator's Manual. The Toro® Company recommends that you retain all receipts covering maintenance on your equipment, but The Toro® Company cannot deny warranty solely for the lack of receipts.
- As the equipment owner, you should however be aware that The Toro® Company may deny you warranty coverage if your emission warranty parts have failed due to abuse, neglect, or improper maintenance or unapproved modifications.
- You are responsible for presenting your equipment to an Authorized Service Dealer as soon as the problem exists. The warranty repairs should be completed in a reasonable amount of time, not to exceed 30 days. If you have a question regarding your warranty coverage, you should contact The Toro® Company at 1-952-948-4027 or call us toll free at the number listed in your Toro Warranty statement.

Defects Warranty Requirements:

1. The warranty period begins on the date the engine or equipment is delivered to an ultimate purchaser.
2. General Evaporative Emissions Warranty Coverage. The emission warranty parts must be warranted to the ultimate purchaser and any subsequent owner that the evaporative emission control system when installed was:
 - A. Designed, built, and equipped so as to conform with all applicable regulations; and
 - B. Free from defects in materials and workmanship that causes the failure of a warranted part for a period of two years.
3. The warranty on evaporative emissions-related parts will be interpreted as follows:
 - A. Any warranted part that is not scheduled for replacement as required maintenance in the written instructions must be warranted for the warranty period of two years. If any such part fails during the period of warranty coverage, it must be repaired or replaced by The Toro® Company. Any such part repaired or replaced under the warranty must be warranted for a time not less than the remaining warranty period.
 - B. Any warranted part that is scheduled only for regular inspection in the written instructions must be warranted for the warranty period of two years. A statement in such written instructions to the effect of "repair or replace as necessary" will not reduce the period of warranty coverage. Any such part repaired or replaced under warranty must be warranted for a time not less than the remaining warranty period.
 - C. Any warranted part that is scheduled for replacement as required maintenance in the written instructions must be warranted for the period of time prior to the first scheduled replacement point for that part. If the part fails prior to the first scheduled replacement, the part must be repaired or replaced by The Toro® Company. Any such part repaired or replaced under warranty must be warranted for a time not less than the remainder of the period prior to the first scheduled replacement point for the part.
 - D. Repair or replacement of any warranted part under the warranty provisions of this article must be performed at no charge to the owner at an Authorized Service Dealer.
 - E. Notwithstanding the provisions of subsection (D) above, warranty services or repairs must be provided at an Authorized Service Dealer.
 - F. The owner must not be charged for diagnostic labor that leads to the determination that a warranted part is in fact defective, provided that such diagnostic work is performed at an Authorized Service Dealer.
 - G. Throughout the evaporative emission control system's two year warranty period, The Toro® Company must maintain a supply of warranted parts sufficient to meet the expected demand for such parts.
 - H. Manufacturer approved replacement parts must be used in the performance of any warranty maintenance or repairs and must be provided without charge to the owner. Such use will not reduce the warranty obligations of The Toro® Company.
 - I. The use of any add-on or modified parts will be grounds for disallowing a warranty claim made in accordance with this article. The Toro® Company will not be liable under this Article to warrant failures of warranted parts caused by the use of an add-on or modified part.
 - J. The Toro® Company shall provide any documents that describe the warranty procedures or policies within five working days of request by the Air Resources Board.

Emission Warranty Parts List:

The following lists includes the parts covered under this warranty:

- Fuel Lines
- Fuel Line Fittings
- Clamps



LCE

The Toro Total Coverage Guarantee

A Limited Warranty

Conditions and Products Covered

The Toro® Company and its affiliate, Toro Warranty Company, pursuant to an agreement between them, jointly promise to repair the listed Toro Products if defective in materials or workmanship.

This warranty applies to:

- ProLine Mid-Size Walk Power Mowers and Accessories
- Z Master Mid-Mount ZRTs and Accessories
- Z Master Outfront ZRTs and Accessories
- Groundsmaster 120 OFRs and Accessories

The following time periods apply from the date of purchase:

Components	Warranty Period
Engines	2 years
Hydraulic Systems	2 years
Traction Unit Frame	2 years
Carrier Frame	2 years
Deck Shells	2 years
Deck Spindles	3 years Parts 2 years Labor
Z500 Series Clutches	2 years
Remaining Components	1 year

This warranty includes the cost of parts and labor, but you must pay transportation costs.

Some engines used on Toro LCE Products are warranted by the engine manufacturer.

Instructions for Obtaining Warranty Service

If you think that your Toro Product contains a defect in materials or workmanship, follow this procedure:

1. Contact any Toro Authorized or Master Service Dealer to arrange service at their dealership. To locate a dealer convenient to you, access our website at www.Toro.com. You may also call our Toro Customer Care Department toll free at 888-577-7466 (U.S. customers) or 877-484-9255 (Canada customers).
2. Bring the product and your proof of purchase (sales receipt) to the Service Dealer.

If for any reason you are dissatisfied with the Service Dealer's analysis or with the assistance provided, contact us at:

Owner Responsibilities

You must maintain your Toro Product by following the maintenance procedures described in the operator's manual. Such routine maintenance, whether performed by a dealer or by you, is at your expense.

Countries Other than the United States or Canada

Customers who have purchased Toro products exported from the United States or Canada should contact their Toro Distributor (Dealer) to obtain guarantee policies for your country, province, or state. If for any reason you are dissatisfied with your Distributor's service or have difficulty obtaining guarantee information, contact the Toro importer. If all other remedies fail, you may contact us at Toro Warranty Company.

Items and Conditions Not Covered

There is no other express warranty except for special emission system coverage on some products. This express warranty does not cover the following:

- Cost of regular maintenance service or parts, such as filters, fuel, lubricants, tune-up parts, blade sharpening, brake and clutch adjustments.
- Any product or part which has been altered or misused or required replacement or repair due to normal wear, accidents, or lack of proper maintenance.
- Repairs necessary due to improper fuel, contaminants in the fuel system, or failure to properly prepare the fuel system prior to any period of non-use over three months.
- Pickup and delivery charges.

All repairs covered by this warranty must be performed by an Authorized Toro Service Dealer using Toro approved replacement parts.

General Conditions

Repair by an Authorized Toro Service Dealer is your sole remedy under this warranty.

Neither The Toro® Company nor Toro Warranty Company is liable for indirect, incidental or consequential damages in connection with the use of the Toro Products covered by this warranty, including any cost or expense of providing substitute equipment or service during reasonable periods of malfunction or non-use pending completion of repairs under this warranty.

Some states do not allow exclusions of incidental or consequential damages, or limitations on how long an implied warranty lasts, so the above exclusions and limitations may not apply to you.

All implied warranties of merchantability (that the product is fit for ordinary use) and fitness for use (that the product is fit for a particular purpose) are limited to the duration of the express warranty.

This warranty gives you specific legal rights, and you may also have other rights which vary from state to state.

LCB Customer Service Department
 Toro Warranty Company
 8111 Lyndale Avenue South
 Bloomington, MN 55420-1196
 888-577-7466 (U.S. customers)
 877-484-9255 (Canada customers)