



## Z557 Z Master<sup>®</sup> With 72in TURBO FORCE<sup>®</sup> Side Discharge Mower

Model No. 74263 - 260000001 and up.

### Parts Catalog

---

#### Ordering Replacement Parts

To order replacement parts, please supply the part number, the quantity, and the description of each part desired.

#### Understanding Reference Numbers

Each Identified part in an illustration has a reference number. The reference number for a part also appears in the parts list, along with other information about the part.

This catalog uses two special reference number formats, one to indicate parts in a service assembly and another to indicate the quantity of a given part in an illustration.

#### Service Assembly Reference Numbers

Parts in service assemblies have reference numbers in the form a:b. The a represents the reference number of the entire service assembly and the b represents a sequential number unique to each part within the service assembly.

For example, a wheel assembly might be identified by reference number 6, the tire by 6:1, the valve by 6:2, and the wheel by 6:3. When you order the assembly identified by reference number 6, you receive all parts identified by reference numbers 6:1, 6:2, and 6:3. However, you may also order any part individually. Reference numbers of this type appear in illustrations and in part lists.

#### Reference Numbers Indicating Quantity

In an illustration, if a reference number indicates more than one part, the reference number has the form nX y. The n represents the quantity of the part, the X is the multiplication symbol, and the y represents the reference number.

For example, in an illustration, the reference number 2X 37 means that two of the parts identified by reference number 37 are indicated.

# Contents

Description	Page	Description	Page
Front Frame Assembly	..... 3	Fuel Tank Assembly	..... 23
Castor and Wheel Assembly	..... 4	Electrical Assembly	..... 24
Main Frame Assembly	..... 5	Crankshaft Assembly Kohler CH750-0010	..... 25
Brake and Wheel Hub Assembly	..... 6	Crankcase Assembly Kohler CH750-0010	..... 26
Steering Control Assembly	..... 7	Oil Pan and Lubrication Assembly Kohler CH750-0010	..... 27
Hydraulic System Assembly	..... 8	Head, Valve and Breather Assembly Kohler CH750-0010	..... 28
Seat and Roll-Over-Protection-System Assembly	..... 10	Ignition and Electrical Assembly Kohler CH750-0010	..... 29
Seat Assembly No. 110-0446	..... 11	Blower Housing and Baffle Assembly Kohler CH750-0010	..... 30
Roll-Over-Protection-System Assembly No. 108-1097	..... 12	Starting System Assembly Kohler CH750-0010	..... 31
Deck Connection Assembly	..... 13	Fuel System Assembly Kohler CH750-0010	..... 32
Deck Assembly	..... 14	Engine Control Assembly Kohler CH750-0010	..... 33
Spindle Assembly No. 106-3217	..... 16	Air Intake and Filtration Assembly Kohler CH750-0010	..... 35
Deck and Decal Assembly No. 107-1625	..... 17	Exhaust Assembly Kohler CH750-0010	..... 34
Rubber Deflector Assembly No. 108-2792	..... 18	Decal Assembly Kohler CH750-0010	..... 37
Lever Assembly No. 107-1664	..... 19		
Drive Idler Assembly	..... 20		
Engine and Clutch Assembly	..... 21		
Muffler and Guard Assembly	..... 22		

## Part Description Abbreviations

Part descriptions in this catalog may include the following abbreviations.

AR. .... as required	INC. .... incorporated
ASM. .... assembly	LH. .... left hand
BBC. .... blade brake clutch	NI. .... nylon insert
CARR. .... carriage	NPTF. .... national pipe thread fine
DEG. .... degrees	PFH. .... phillips flat head
EXT. .... external	PPH. .... phillips pan head
FH. .... flat head	PPHTF. .... phillips pan head thread forming
GA. .... gauge	PRH. .... phillips round head
HF. .... hex flange	PTH. .... phillips truss head
HH. .... hex head	PTO. .... power-take-off
HHF. .... hex head flange	RH. .... right hand
HHFTF. .... hex head flange thread forming	ROPS. .... roll-over-protection-system
HJ. .... hex jam	SFH. .... slotted fillister head
HLH. .... hex lag head	SHH. .... slotted hex head
HOC. .... height-of-cut	SHWH. .... slotted hex washer head
HSBH. .... hex socket button head	SPH. .... slotted pan head
HSFH. .... hex socket flat head	SQH. .... square head
HSH. .... hex socket head	SRH. .... slotted round head
HWH. .... hex washer head	STD. .... standard
HWHTF. .... hex washer head thread forming	TAP. .... self tapping
HYD. .... hydraulic	TTH. .... torx truss head

## Footnotes

- |                      |  |
|----------------------|--|
| ❶ Not illustrated    | ❷ Not serviced separately              |
| ❸ Optional Equipment | ❹ Obtain from your local Kohler dealer |

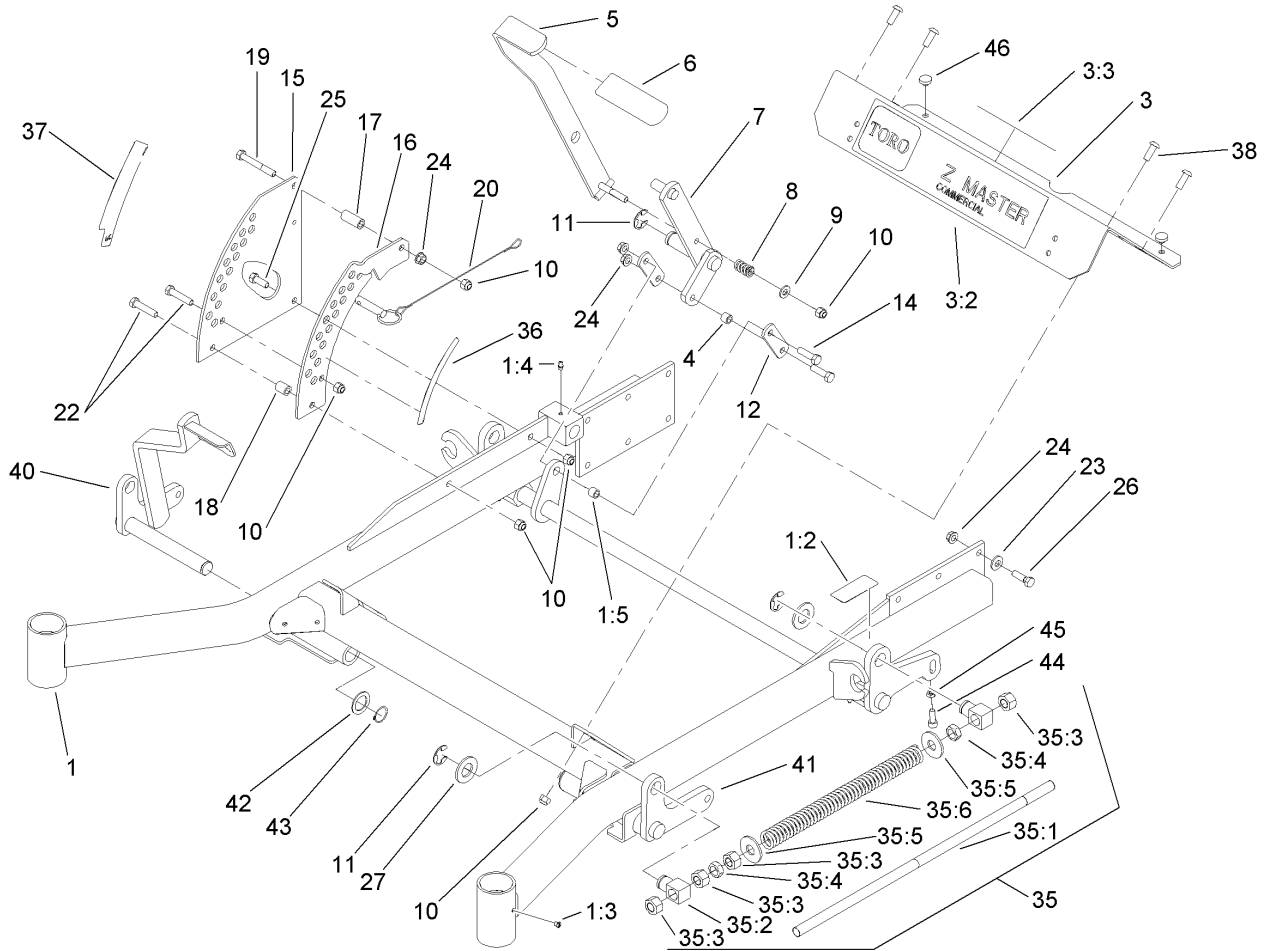

## Front Frame Assembly

Ref	Part No.	Qty.	Description
1	107-8084	1	Front Frame ASM
1:2	107-1857	1	Decal-Brake, Parking
1:3	1-811010	2	Plug
1:4	302-19	5	Fitting-Grease
1:5	103-1918	1	Bushing
3	106-9981	1	Front Floorpan ASM
3:2	106-7451	1	Decal
3:3	107-2112	1	Decal-Warning
4	103-1918	1	Bushing
5	103-2083-03	1	Lift Lever ASM
6	1-633295	1	Grip-Lever, Lift
7	103-2064-03	1	Arm-Lift, Deck
8	1-633325	1	Spring-Compression
9	3256-24	1	Washer-Flat
10	3296-39	9	Nut-Lock, NI
11	32151-103	5	Ring-Snap
12	1-633068	2	Arm-Lift, Deck
14	323-29	2	Screw-HH
15	1-633889-01	1	Plate-Lift, Deck
16	108-7759-01	1	Plate-Lift, Deck
17	1-633082	1	Bushing-Lever, Lift
18	1-633080	1	Bushing-Lever, Lift
19	323-13	1	Screw-HH
20	106-9951	1	Hitch Pin ASM

Ref	Part No.	Qty.	Description
22	323-9	2	Screw-HH
23	98-5975	12	Washer-Belleville
24	3290-357	15	Nut-HHF, Whiz
25	323-6	1	Screw-HH
26	323-7	12	Screw-HH
27	3256-29	4	Washer-Flat
● 35		2	Front Frame Spring ASM
35:1	1-633096	1	Rod-Lift, Deck
35:2	1-633441	2	Swivel-Deck Mount, Rear
35:3	3217-11	3	Nut-Hex
35:4	3218-6	3	Nut-Jam
35:5	3256-7	2	Washer-Flat
35:6	1-643015	1	Spring-Support, Deck
36	107-1861	1	Decal-Height, Deck
37	107-1860	1	Decal-Height, Deck
38	3274-94	4	Screw-HSBH
40	108-7786-01	1	RH Front Deck Lift ASM
41	106-8984-01	1	LH Deck Lift ASM
42	1-523157	2	Washer-Spacer, 14 GA
43	32151-29	2	Ring-Retaining
44	3274-18	2	Screw-HSH
45	3218-2	2	Nut-Jam
46	1-513658	2	Bumper

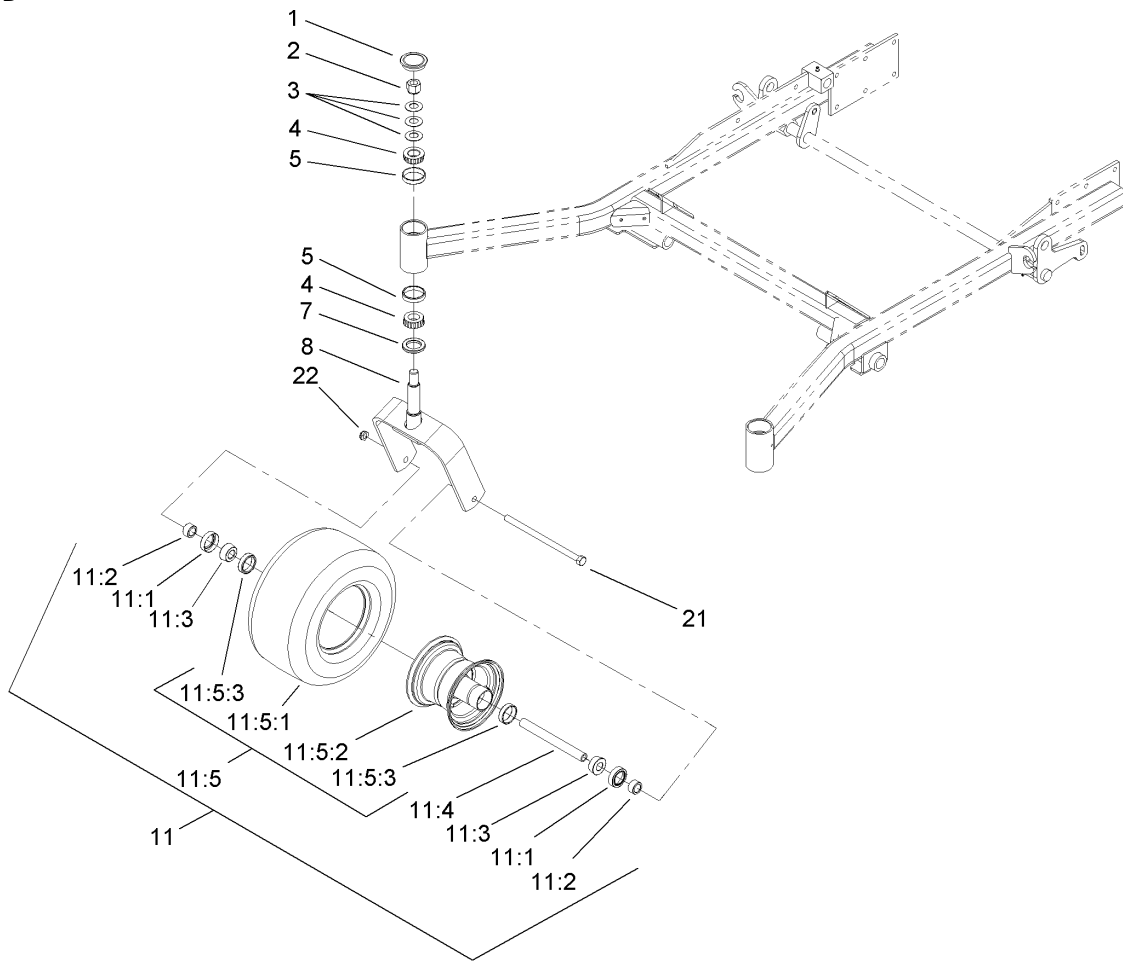

## Castor and Wheel Assembly

Ref	Part No.	Qty.	Description
1	103-4882	2	Cap-Grease
2	3296-51	2	Nut-Lock, NI
3	1-633508	6	Washer-Bellville
4	254-94	4	Bearing-Cone, Tapered
5	254-72	4	Bearing-Cup, Tapered
7	1-543511	2	Seal-Grease
8	103-1474-01	2	Fork-Caster
11	1-644251	2	Caster Wheel ASM
11:1	1-633580	2	Seal-Bearing
11:2	1-633581	2	Spacer-Bearing
11:3	1-633585	2	Bearing-Cone, Taper
11:4	1-633959	1	Spacer-Caster, Front
11:5		1	Wheel And Tire ASM
11:5:1	1-523009	1	Tire
11:5:2	1-633987	1	Wheel
11:5:3	1-633584	2	Bearing-Cup
21	325-39	2	Screw-HH
22	3296-23	2	Nut-Lock, NI

Ref	Part No.	Qty.	Description

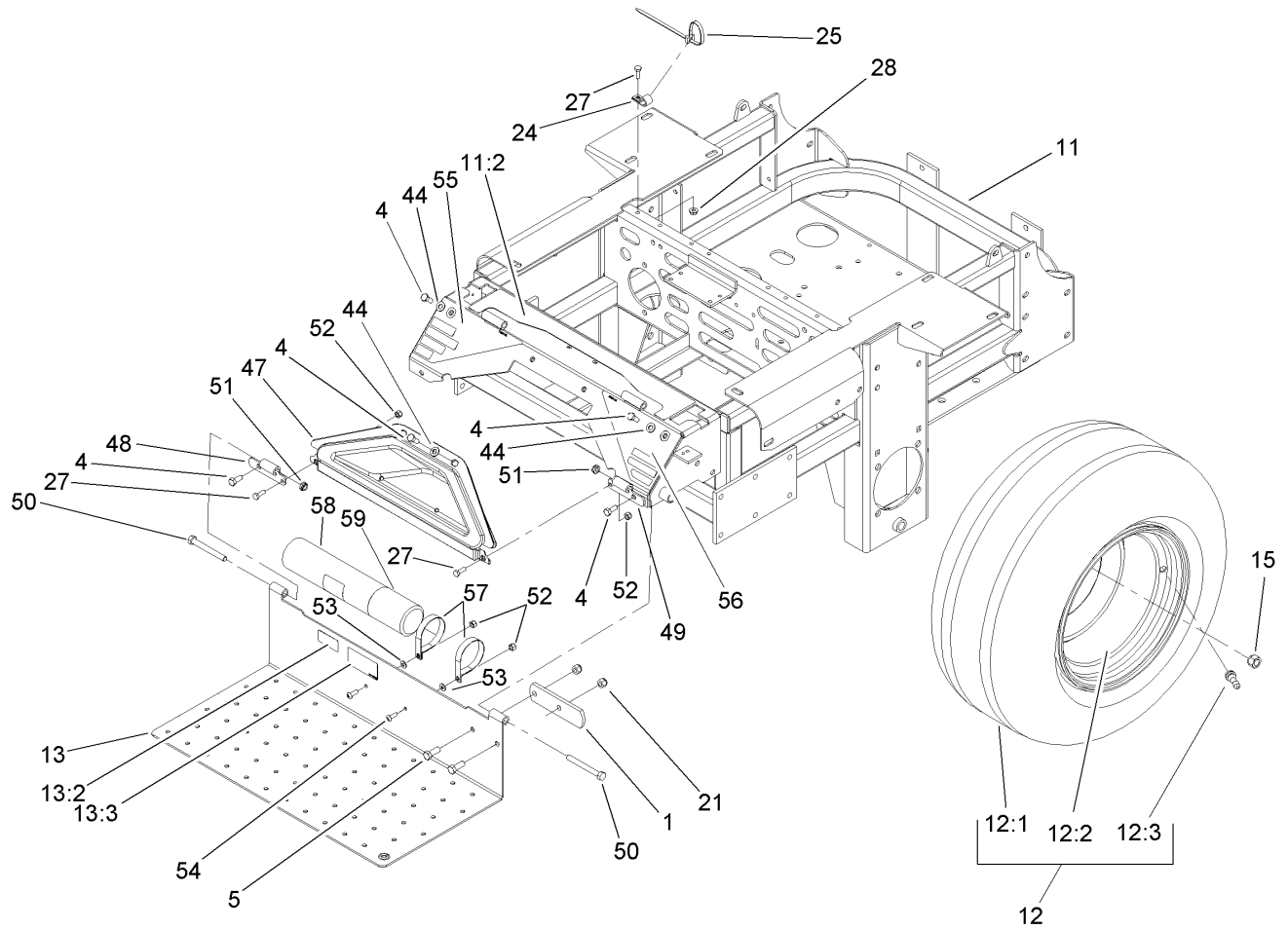

## Main Frame Assembly

Ref	Part No.	Qty.	Description
1	1-633964-03	1	Stop-Brake, Park
4	322-43	6	Screw-HH
5	323-6	2	Screw-HH
11	108-1095	1	Main Frame ASM
11:2	107-8076	1	Decal-Console, Top
12	1-633970	2	Wheel And Tire ASM
12:1	1-633993	1	Tire
12:2	1-633992	1	Wheel
12:3	232-27	1	Stem-Valve
13	107-1858	1	Floorpan
13:2	98-4387	1	Decal-Protection, Ear
13:3	107-1864	1	Decal-Location, Manual
15	242-50	8	Nut-Lug
21	3296-39	2	Nut-Lock, NI
24	1-513762	1	Clip-Loom
25	1-303335	1	Tie-Plastic
27	321-4	3	Screw-HH
28	32128-33	1	Nut-HF
44	3256-70	6	Washer-Flat
47	106-7498	1	Pocket
48	106-7488-03	1	Hinge-Floorpan, LH
49	106-7489-03	1	Hinge-Floorpan, RH
50	323-20	2	Screw-HH
51	3296-59	2	Nut-Lock, NI

Ref	Part No.	Qty.	Description
52	3296-42	4	Nut-Lock, NI
53	3256-63	2	Washer-Flat
54	3258-166	2	Screw-PRH
55	106-9989	1	Decal-Warning
56	106-7492	1	Decal-Danger
57	107-1865	2	R-Clamp
58	104-7050	1	Housing-Manual
59	104-7048	1	Cap-Housing

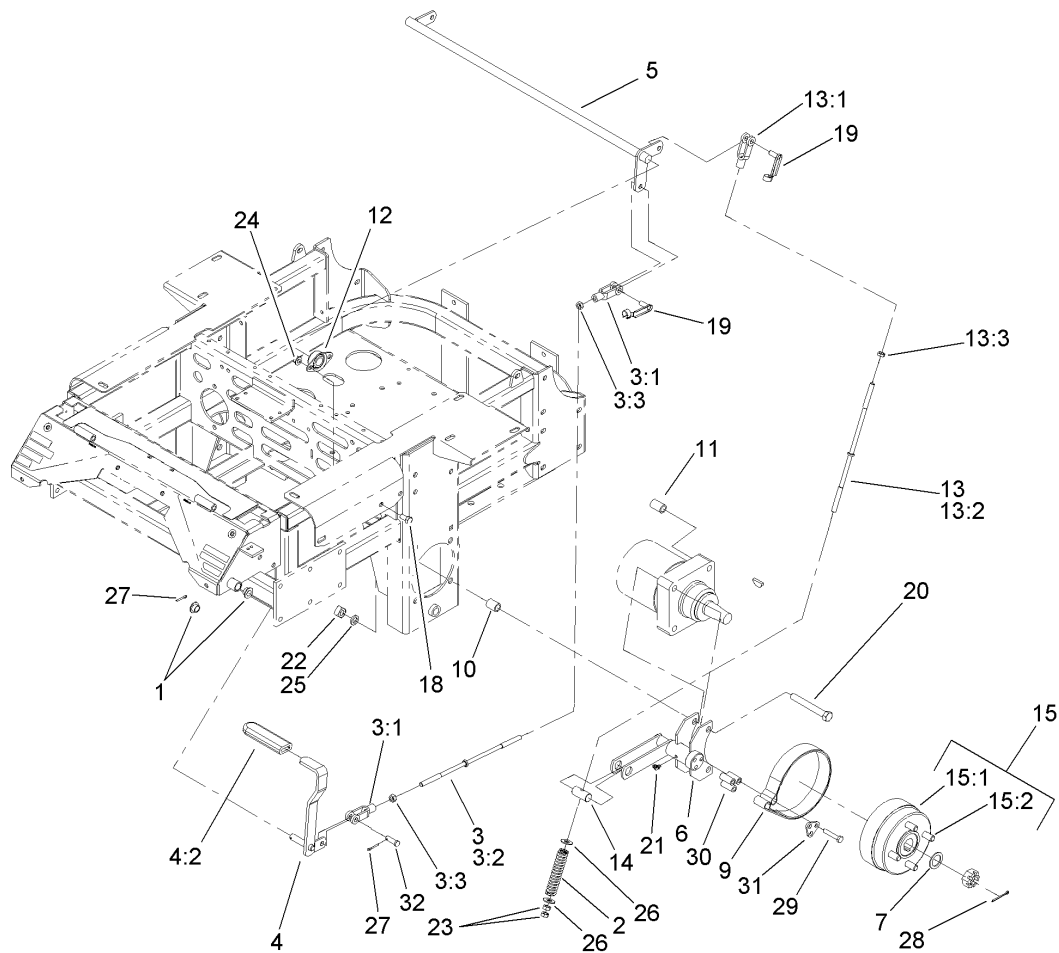

## Brake and Wheel Hub Assembly

Ref	Part No.	Qty.	Description
1	1-513140	2	Bearing-Control
2	1-633454	2	Spring-Brake
3	103-4332	1	Brake Rod And Yoke ASM
3:1	1-633131	2	Yoke-Linkage, Brake
3:2	1-633477	1	Rod-Brake
3:3	3219-3	2	Nut-Hex
4	1-634500	1	Brake Lever ASM
4:2	1-633268	1	Grip-Lever, Brake
5	1-632217-03	1	Shaft-Brake
6	103-0354-03	2	Bracket-Brake ASM
7	1-523157	2	Washer-Spacer, 14 GA
9	103-0355	2	Band-Brake
10	1-633060	4	Spacer-Wheel, Short
11	1-633062	4	Spacer-Wheel, Long
12	1-633102	2	Bearing-Flange, Side
13	103-4333	2	Brake Rod And Yoke ASM
13:1	1-633131	1	Yoke-Linkage, Brake
13:2	1-633477	1	Rod-Brake
13:3	3219-3	1	Nut-Hex
14	1-633144	2	Pin-Trunion
15	103-0590	2	Hub And Wheel ASM
15:1	103-0589	1	Wheel Hub ASM
15:2	1-633926	4	Stud-Wheel
18	323-4	4	Screw-HH

Ref	Part No.	Qty.	Description
19	103-2399	3	Pin-Spring, Clevis
20	325-20	8	Screw-HH
21	302-19	2	Fitting-Grease
22	103-0131	8	Nut-Square
23	3219-3	4	Nut-Hex
24	3290-357	4	Nut-HHF, Whiz
25	3253-7	8	Washer-Lock
26	3256-4	4	Washer-Flat
27	3272-10	2	Pin-Cotter
28	1-806800	2	Pin-Cotter
29	322-9	6	Screw-HH
30	103-0384	6	Spacer
31	103-0374	2	Retainer-Band, Brake
32	1-808285	1	Pin-Clevis

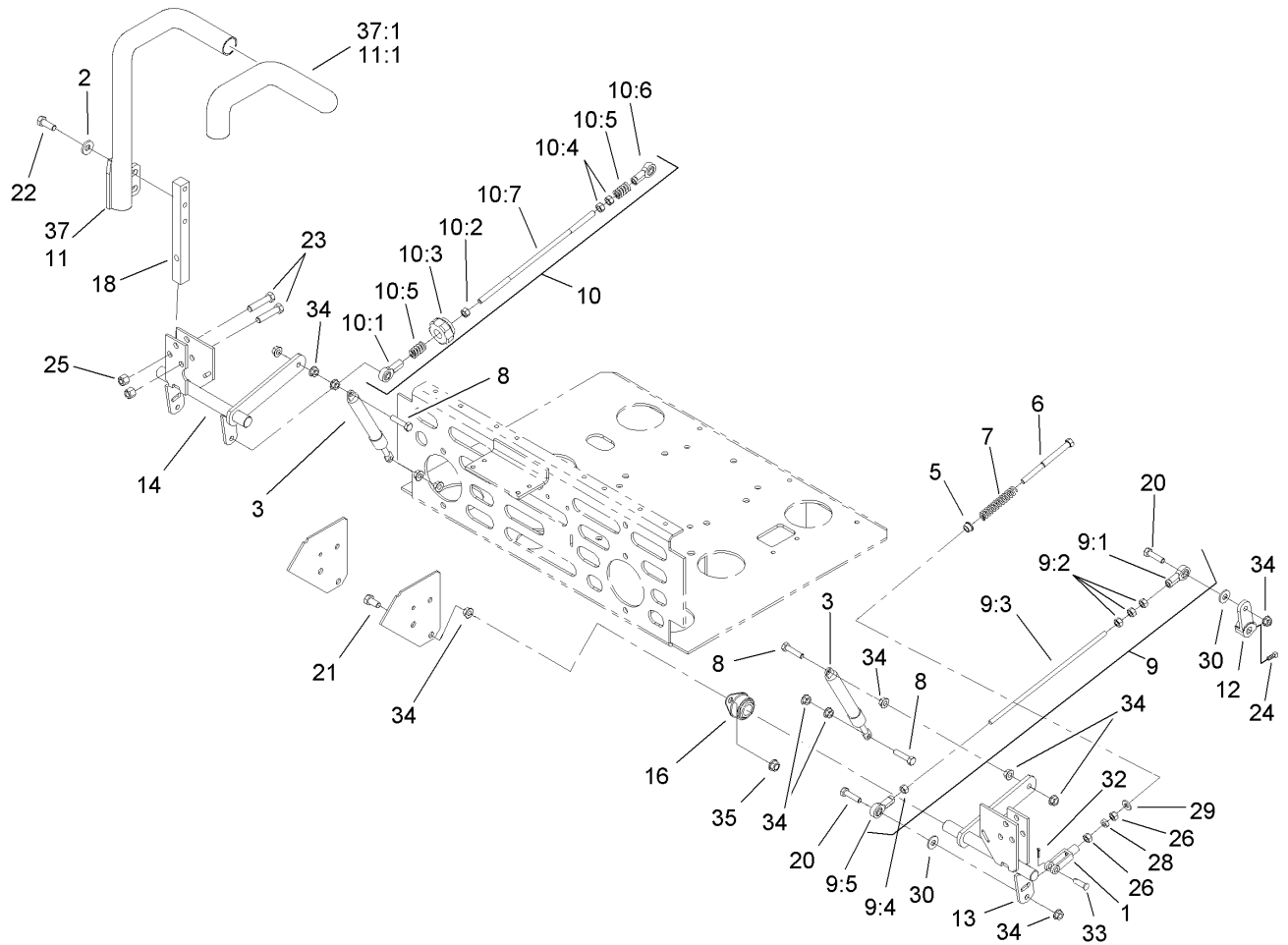

## Steering Control Assembly

Ref	Part No.	Qty.	Description
1	1-303105	2	Yoke-Adjustable
2	98-5975	4	Washer-Belleville
3	103-4079	2	Damper-Control, Motion
5	1-603735	2	Bushing-Flanged
6	1-603737	2	Bolt-Return, Neutral
7	1-603807	2	Spring-Return, Neutral
8	1-403180	4	Screw-HH
9	103-4331	1	Tracking Rod ASM
9:1	1-543017	1	Balljoint-RH
9:2	3219-2	3	Nut-Hex
9:3	103-3064	1	Link-Rod, Tracking
9:4	1-804524	1	Nut
9:5	1-633152	1	Balljoint-Thread, LH
10	103-4330	1	Tracking Rod ASM
10:1	1-543017	1	Balljoint-RH
10:2	3219-2	1	Nut-Hex
10:3	103-3060	1	Knob-Tracking
10:4	1-804524	2	Nut
10:5	1-323245	2	Spring-Compression
10:6	1-633152	1	Balljoint-Thread, LH
10:7	103-3064	1	Link-Rod, Tracking
11	108-7238	1	LH Lever ASM
11:1	106-9987	1	Grip-Control, Motion
12	1-632208	2	Arm-Control, Pump

Ref	Part No.	Qty.	Description
13	103-4781	1	Control-Motion, LH
14	103-4782	1	Control-Motion, RH
16	1-633102	4	Bearing-Flange, Side
18	103-0407	2	Arm-Shaft, Control
20	322-6	4	Screw-HH
21	323-4	8	Screw-HH
22	323-6	4	Screw-HH
23	323-9	6	Screw-HH
24	1-803022	2	Screw-Set
25	3296-39	6	Nut-Lock, NI
26	3219-2	4	Nut-Hex
28	3220-2	2	Nut-Jam
29	3256-2	2	Washer-Flat
30	3256-3	4	Washer-Flat
32	3272-5	2	Pin-Cotter
33	1-808280	2	Pin-Clevis
34	32128-20	16	Nut-HF
35	3290-357	8	Nut-HHF, Whiz
37	108-7237	1	RH Lever ASM
37:1	106-9987	1	Grip-Control, Motion

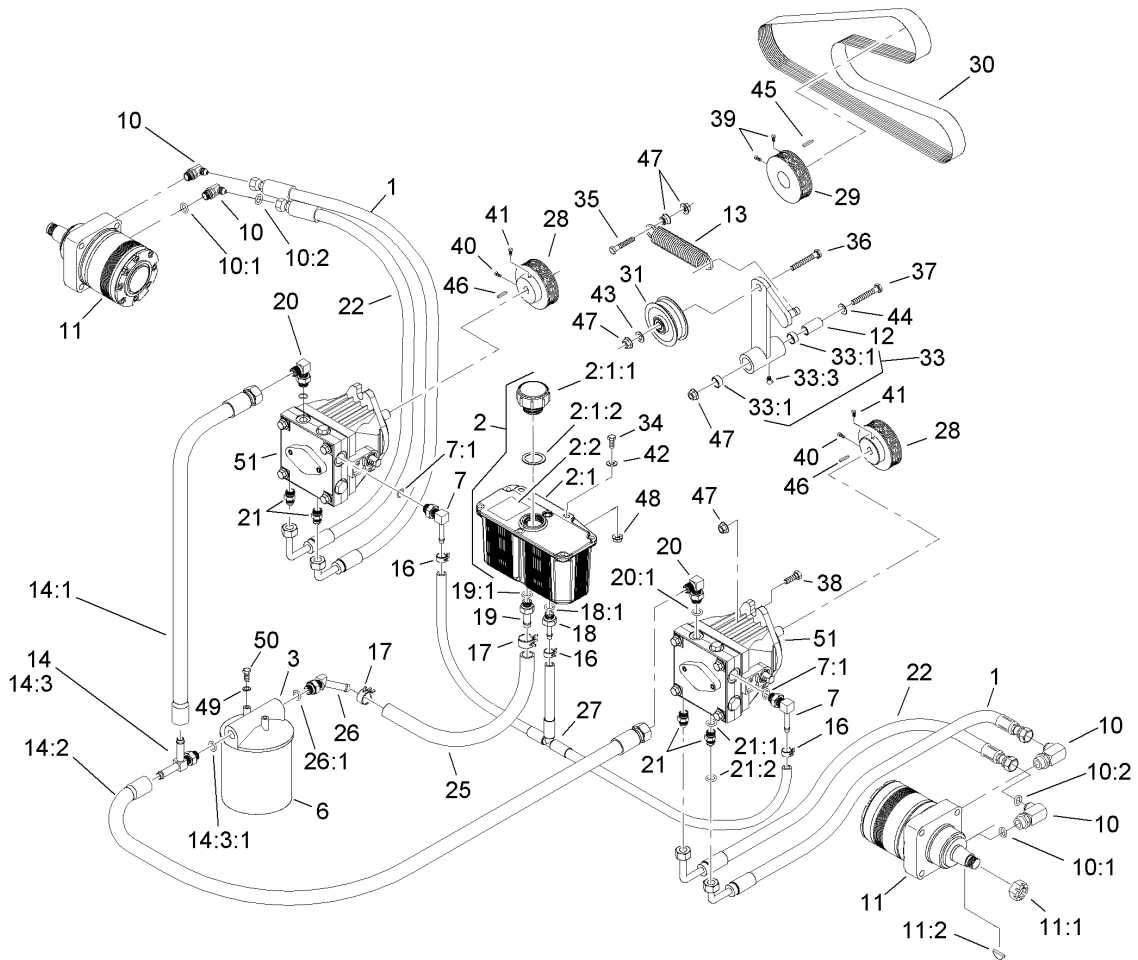

## Hydraulic System Assembly

Ref	Part No.	Qty.	Description
1	103-3734	2	HYD Hose ASM
2	103-1947	1	HYD Reservoir ASM
2:1		1	Reservoir-HYD
2:1:1	103-1948	1	Cap-Reservoir, HYD
2:1:2	103-1949	1	Gasket-Cap
2:2	1-523552	1	Decal-Tank, HYD
3	104-7836	1	Head-Filter
6	1-633752	1	Filter-HYD, Winter
6	1-633750	1	Filter-HYD
7	103-1799	2	Elbow-90 DEG
7:1	237-42	1	O-Ring
10	1-633786	4	Fitting-90 DEG
10:1	237-80	1	O-Ring
10:2	1-603992	1	O-Ring
11	103-6988	2	Motor-Wheel
11:1	1-809036	1	Nut-HH
11:2	3257-42	1	Key-Woodruff
11:99	1-000099	1	Seal Kit
11:99	1-000139	1	Bearing Kit
11:99	103-2748	1	Drive Link Kit
12	1-603384	1	Bushing-Pivot, Idler
13	103-3330	1	Spring-Extension
14	109-1936	1	Pump Inlet Hose ASM
14:1	103-1826	1	HYD Hose ASM

Ref	Part No.	Qty.	Description
14:2	103-1827	1	HYD Hose ASM
14:3	103-1828	1	Adapter-Run, Tee
14:3:1	237-42	1	O-Ring
16	103-1716	3	Clamp-Hose
17	103-1988	2	Clamp-Hose
18	103-1801	1	Adapter-Straight
18:1	237-42	1	O-Ring
19	103-1912	1	Adapter-Straight
19:1	237-42	1	O-Ring
20	103-1802	2	Fitting-HYD, 90 DEG
20:1	1-603921	1	O-Ring
21	1-603990	4	Fitting-Straight
21:1	1-603920	1	O-Ring
21:2	1-603992	1	O-Ring
22	103-1863	2	Hose-Lower
25	103-1808	1	Hose-HYD
26	103-1807	1	Elbow-45 DEG
26:1	237-42	1	O-Ring
27	103-1806	1	HYD Hose ASM
28	103-6907	2	Sheave
29	1-633567	1	Sheave
30	103-7445	1	Belt-V
31	1-633167	1	Sheave-Idler
33	1-634277	1	Bearing Arm ASM

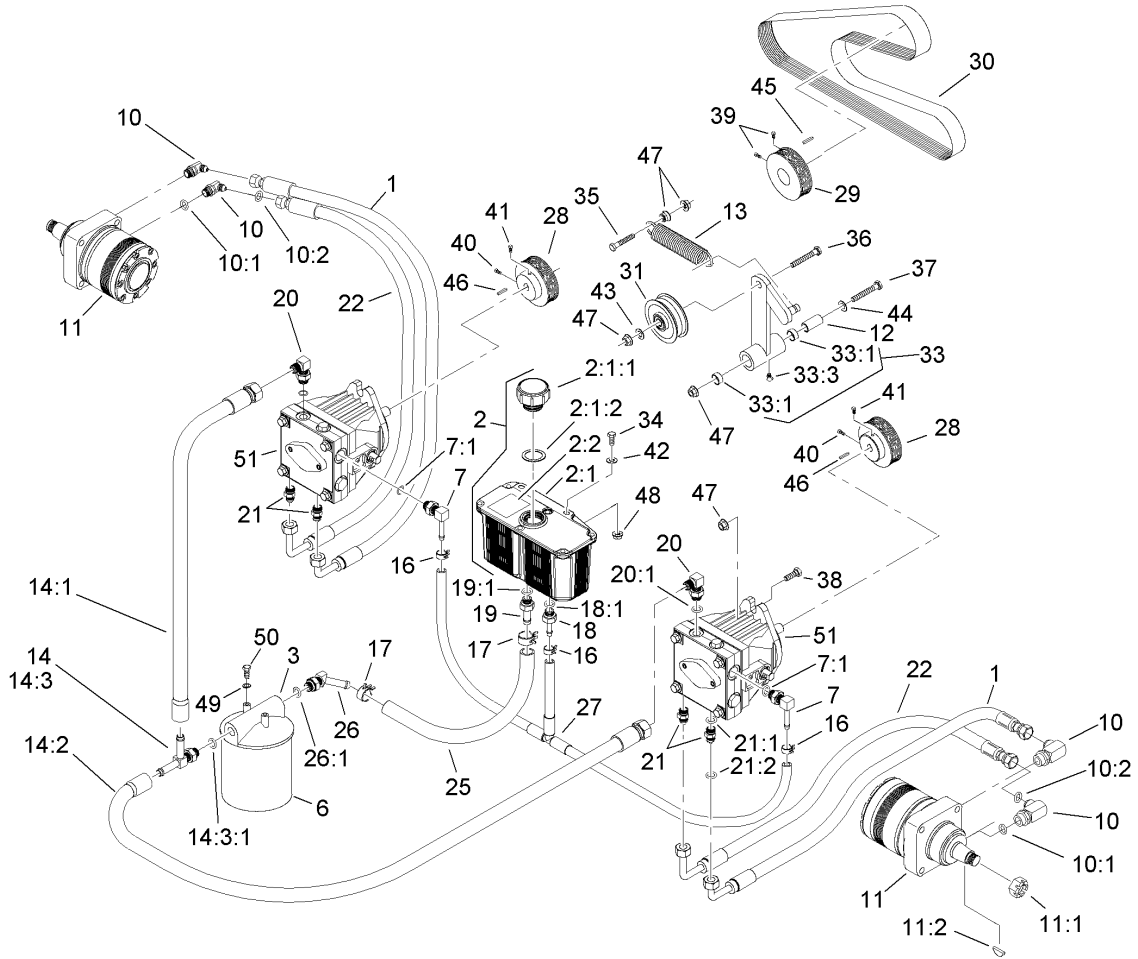

## Hydraulic System Assembly (continued)

Ref	Part No.	Qty.	Description
33:1	1-513034	2	Sleeve-Bearing
33:3	302-40	1	Fitting-Grease
34	321-6	2	Screw-HH
35	323-8	1	Screw-HH
36	323-9	1	Screw-HH
37	1-800805	1	Screw-HH
38	323-7	4	Screw-HH
39	1-803022	2	Screw-Set
40	30-1710	2	Screw
41	1-803050	2	Screw-Set
42	3256-22	2	Washer-Flat
43	3256-3	1	Washer-Flat
44	3256-4	1	Washer-Flat
45	13-2840	1	Key-Square
46	5-1077	2	Key-Square
47	3290-357	8	Nut-HHF, Whiz
48	32128-33	2	Nut-HF
49	1-805004	2	Washer-Lock
50	321-3	2	Screw-HH
51	103-7262	2	Pump-HYD
●51:1	103-7441	1	Bearing-Shaft, Input
●51:2	103-7443	1	Cylinder Block Kit
●51:3	103-8448	1	Thrust Bearing Kit
●51:4	105-6184	1	Overhaul Seal Kit

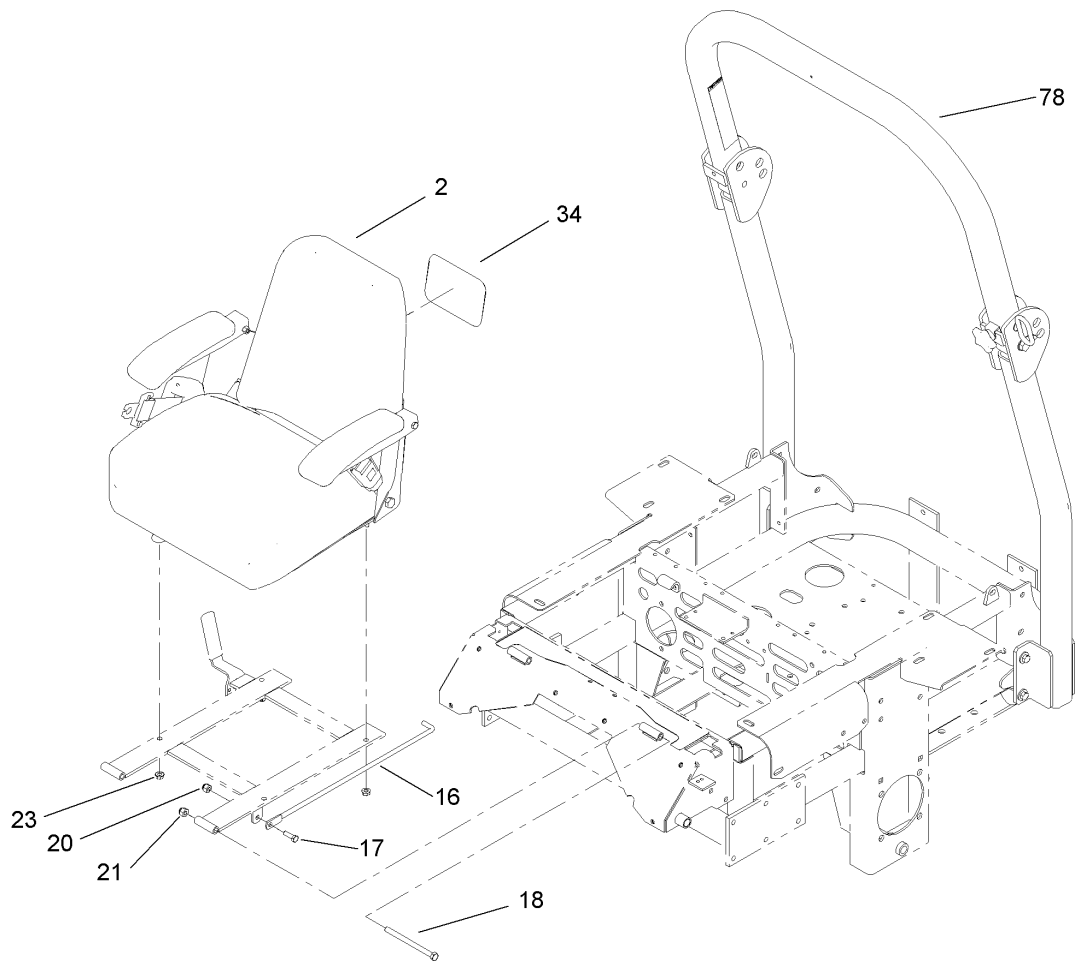
## Seat and Roll-Over-Protection-System Assembly

Ref	Part No.	Qty.	Description				
2	110-0446	1	Seat ASM				
16	1-633293	1	Rod-Holdup, Seat				
17	322-5	1	Screw-HH				
18	323-39	2	Screw-HH				
20	3296-29	3	Nut-Lock, NI				
21	3296-39	3	Nut-Lock, NI				
23	32128-20	4	Nut-HF				
34	99-4693	1	Decal				
78	108-1097	1	ROPS ASM				



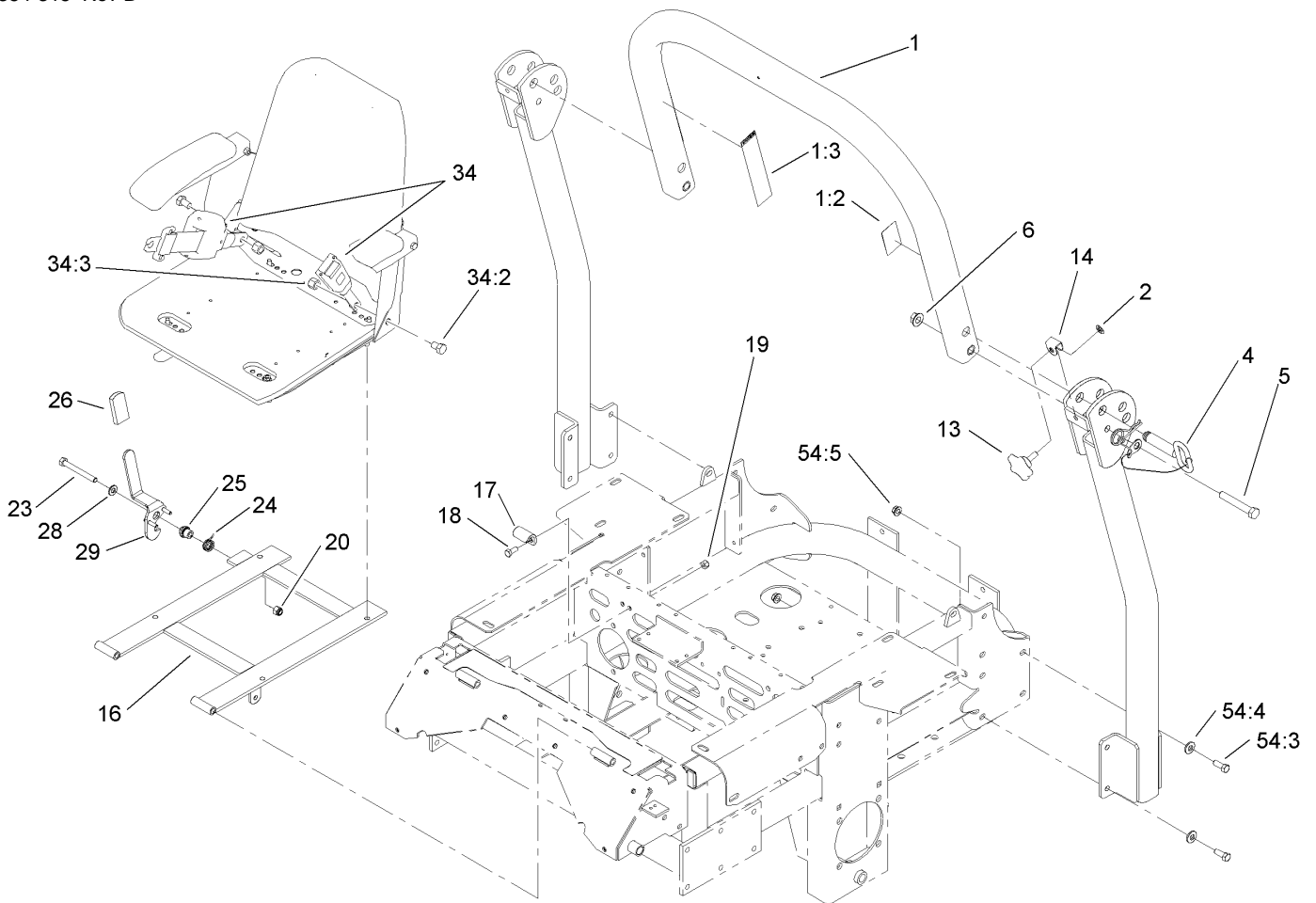

## Roll-Over-Protection-System Assembly No. 108-1097

Ref	Part No.	Qty.	Description
① 1		1	Upper Tube ASM
1:2	107-2101	1	Decal-ROPS
1:3	107-2102	1	Decal-Warning, Folding ROPS
2	107-3154	2	Nut-Push
4	103-4553	2	ROPS Fold Pin ASM
5	325-13	2	Screw-HH
6	32128-23	2	Nut-HF
13	106-0887	2	Knob
14	107-3124	2	Clip
16	107-3052-03	1	Seat Support Frame ASM
17	107-3058	1	Catch-Latch, Seat
18	322-3	2	Screw-HH
19	3296-29	2	Nut-Lock, NI
20	3296-39	1	Nut-Lock, NI
23	323-20	1	Screw-HH
24	107-0076	1	Spring-Torsion
25	107-0075	1	Bushing-Latch, Seat
26	103-4434	1	Grip-Lever
28	3256-24	1	Washer-Flat
29	107-3083	1	Latch ASM
34	110-0883	1	Retractable Seatbelt Kit
34:2	3212-4	2	Screw-HH
34:3	3296-7	2	Nut-Lock
① ② 54		1	Bag-Bolt, ROPS

Ref	Part No.	Qty.	Description
54:3	323-6	8	Screw-HH
54:4	98-5975	8	Washer-Belleville
54:5	3290-357	8	Nut-HHF, Whiz



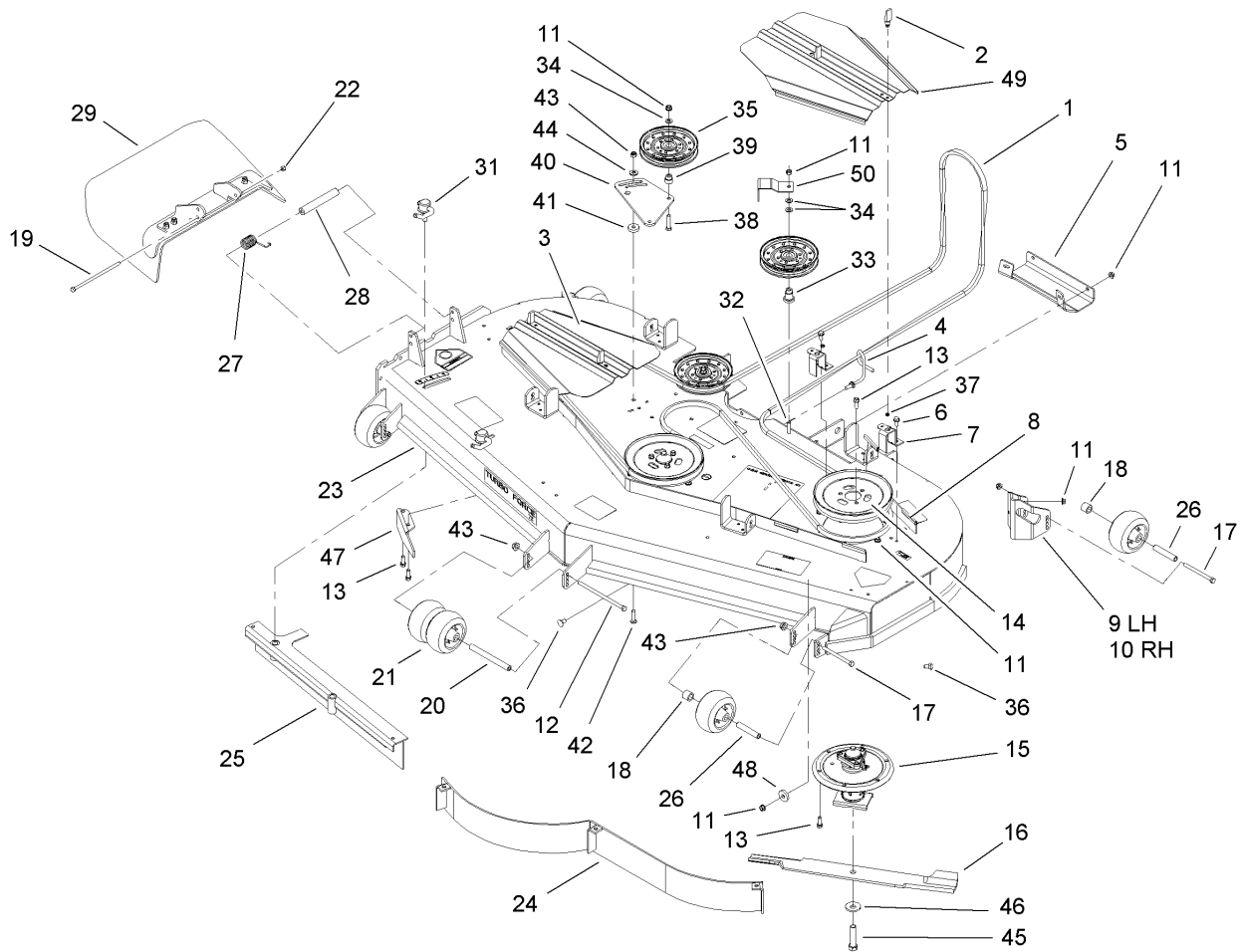

## Deck Assembly

Ref	Part No.	Qty.	Description
1	106-7350	1	Belt
2	74-5950	4	Latch-Swell
3	105-8786-03	1	Cover-Belt
4	106-3220	1	Guide-Belt
5	106-3279-01	1	Plate-Skid
6	32144-70	4	Screw-HH
7	108-4121-01	4	Bracket-Cover
8	105-7699	8	Strip-Seal
9	106-7354-01	1	Plate-Roller, LH
10	106-7355-01	1	Plate-Roller, RH
11	3290-357	38	Nut-HHF, Whiz
12	323-28	1	Screw-HH
13	92-1624	33	Screw
14	105-7733	3	Pulley
15	106-3217	3	Spindle ASM
16	105-7784-03	3	Blade-Hi Flow, 24.5 Inch
17	323-23	4	Screw-HH
18	98-7913	4	Tube-Spacer
19	322-50	1	Screw-HH
20	98-5967	1	Spacer-Wheel
21	1-603299	6	Roller-Scalp, Anti
22	3296-29	1	Nut-Lock, NI
23	107-1625	1	Deck ASM
24	105-7730-01	1	Baffle ASM

Ref	Part No.	Qty.	Description
25	105-7669-01	1	Baffle ASM
26	98-7912	4	Tube-Spanner
27	108-4052	1	Spring-Torsion
28	105-4622	1	Spacer
29	108-2792	1	Rubber Deflector ASM
31	107-1664	2	Lever ASM
32	323-12	2	Screw-HH
33	106-3214	2	Mount-Pulley
34	3256-24	4	Washer-Flat
35	1-633109	3	Idler-Flat
36	3231-1	10	Screw-CARR
37	99-3058	4	Washer
38	323-9	1	Screw-HH
39	1-603496	1	Bushing-Idler
40	105-7787-01	1	Plate-Idler
41	105-7788	2	Spacer
42	3231-4	2	Screw-CARR
43	3296-39	7	Nut-Lock, NI
44	98-5975	1	Washer-Belleville
45	103-0862	3	Screw-Cap
46	103-0865	3	Washer-Blade Bolt, Heavy
47	106-3216-01	1	Baffle-Discharge
48	112843	1	Washer
49	106-3275-03	1	Cover-Belt



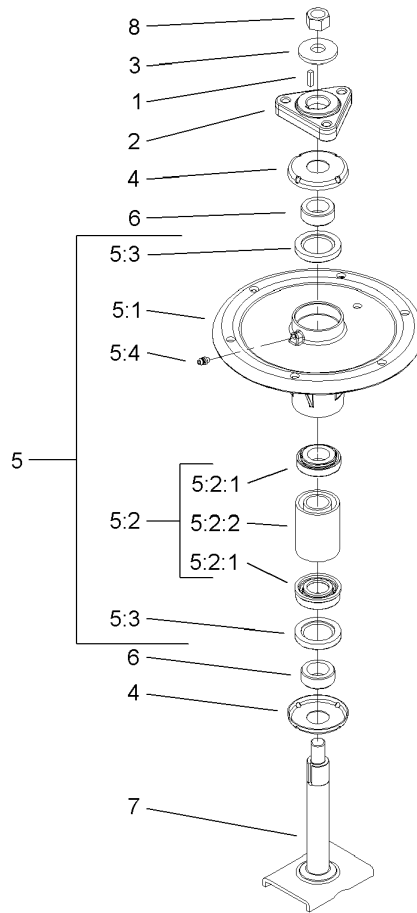

## Spindle Assembly No. 106-3217

Ref	Part No.	Qty.	Description				
1	10-8040	1	Key-Square				
2	106-3277	1	Hub-Pulley				
3	103-0865	1	Washer-Blade Bolt, Heavy				
4	106-3204	2	Shield-Bearing				
5		1	Spindle Bearing ASM				
5:1	106-3211	1	Housing-Spindle				
5:2	106-3207	1	Bearing ASM				
5:2:1	27-0960	1	Bearing ASM				
5:2:2	106-3206	1	Spacer-Set, Matched				
5:3	253-133	2	Seal-Oil				
5:4	302-5	1	Fitting-Grease				
6	106-3218	2	Spacer-Seal				
7	106-3233	1	Spindle Shaft ASM				
8	3219-6	1	Nut-Hex				

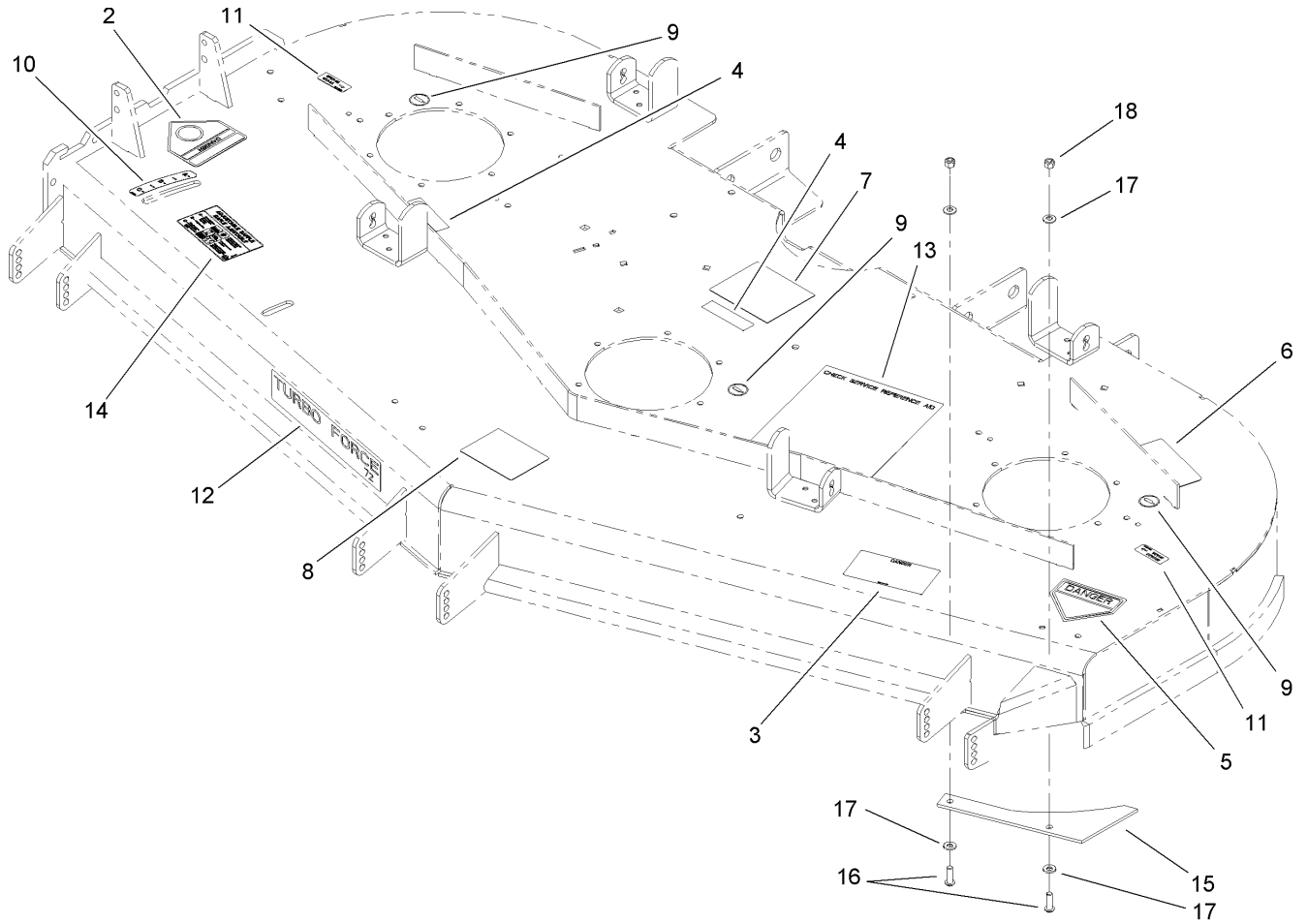

## Deck and Decal Assembly No. 107-1625

Ref	Part No.	Qty.	Description
2	54-9220	1	Decal-Danger
3	66-1340	1	Decal-Danger
4	98-5954	3	Decal-Missing, Cover
5	1-403005	1	Decal-Danger
6	68-8340	1	Decal-Torque
7	105-7797	1	Decal-Routing, Belt
8	105-7798	1	Decal-Scalp, Anti
9	58-6520	3	Decal-Grease
10	110-2067	1	Decal-Setting, Baffle
11	107-1613	2	Decal-Grease
12	107-1620	1	Decal
13	107-1621	1	Decal-Service, Check
14	110-2068	1	Decal-Adjustment, Baffle
15	107-3138	1	Plate-Turbo
16	3274-104	2	Screw-HSBH
17	1-303334	4	Washer-Spring
18	3296-29	2	Nut-Lock, NI

--	--	--	--





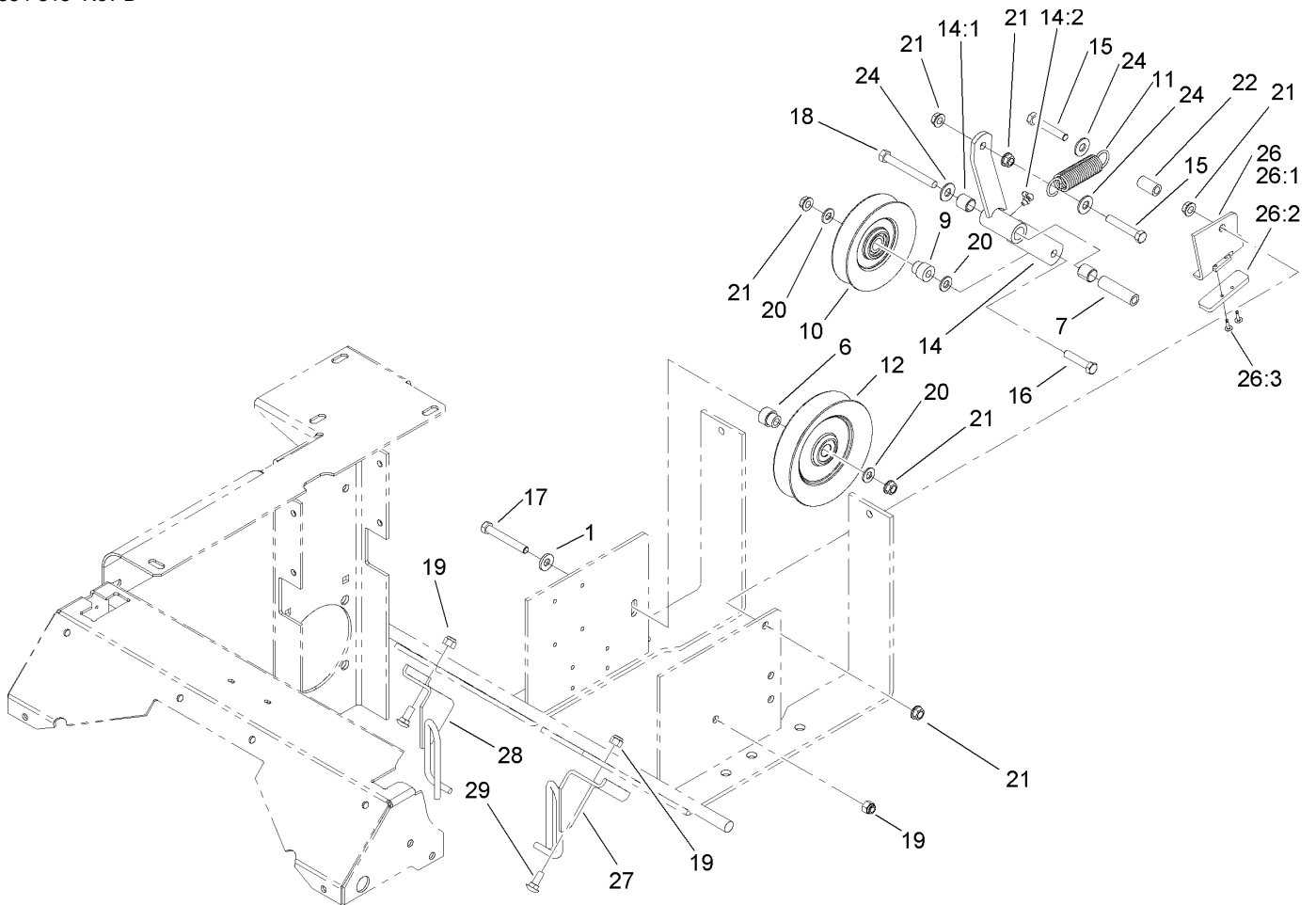

### Drive Idler Assembly

Ref	Part No.	Qty.	Description
1	98-5975	1	Washer-Belleville
6	103-2627	1	Bushing-Idler
7	1-603384	1	Bushing-Pivot, Idler
9	1-603496	1	Bushing-Idler
10	99-4638	1	Idler
11	1-603402	1	Spring-Extension
12	1-633166	1	Pulley-Idler
14	103-3147	1	Arm ASM
14:1	1-513034	2	Sleeve-Bearing
14:2	302-40	1	Fitting-Grease
15	323-12	2	Screw-HH
16	323-9	1	Screw-HH
17	323-13	1	Screw-HH
18	1-800805	1	Screw-HH
19	3296-39	3	Nut-Lock, NI
20	3256-24	3	Washer-Flat
21	3290-357	6	Nut-HHF, Whiz
22	1-603401	1	Spacer-Fender
24	3256-4	3	Washer-Flat
26	106-3271	1	Travel Limiter ASM
26:1	106-3228-03	1	Plate-Limiter, Pulley
26:2	106-3229	1	Pad-Bumper
26:3	3269-24	2	Rivet
27	108-7204-03	1	Guide-Belt, LH

Ref	Part No.	Qty.	Description
28	108-7229-03	1	Guide-Belt, RH
29	3231-2	2	Screw-CARR



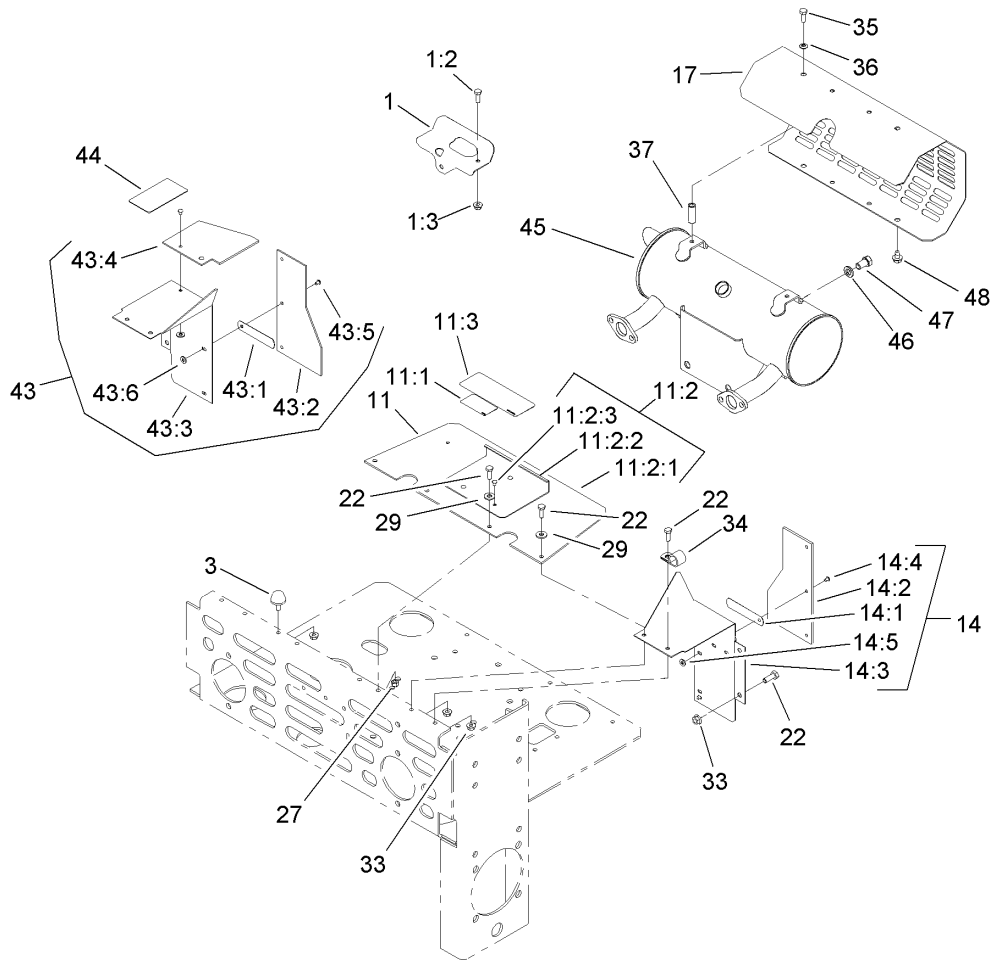

## Muffler and Guard Assembly

Ref	Part No.	Qty.	Description
1	103-3535	1	Cable Heat Shield Kit
1:2	321-4	1	Screw-HH
1:3	32128-33	1	Nut-HF
3	1-523420	2	Bumper
11	1-644276	1	Shield ASM
11:1	1-633462	1	Decal-Important
11:2	1-634308	1	Shield/Lift ASM
11:2:1	103-1308	1	Shield-Engine
11:2:2	1-633300-03	1	Lift-Shield
11:2:3	1-803035	3	Rivet-Pop
11:3	103-5881	1	Decal-Devices, Rotating
14	1-634796	1	LH Shield ASM
14:1	1-523285	1	Clip-Baffle, Rear
14:2	1-633301	1	Shield-Engine
14:3	1-633795-03	1	Baffle-Engine Shield, LH
14:4	1-803035	3	Rivet-Pop
14:5	3256-63	3	Washer-Flat
17	1-643313-03	1	Guard-Muffler
22	321-4	10	Screw-HH
27	3296-42	4	Nut-Lock, NI
29	3256-2	4	Washer-Flat
33	32128-33	8	Nut-HF
34	1-633396	1	Clip-Loom
35	1-809108	2	Screw-HWH

Ref	Part No.	Qty.	Description
36	1-323235	2	Washer-Spring
37	1-323236	2	Spacer
43	1-644316	1	RH Shield ASM
43:1	1-523285	1	Clip-Baffle, Rear
43:2	1-633301	1	Shield-Engine
43:3	1-633794-03	1	Shield-RH
43:4	1-643315	1	Baffle-Cooler, Engine
43:5	1-803035	5	Rivet-Pop
43:6	3256-63	5	Washer-Flat
44	1-643339	1	Decal-Routing, Belt
45	103-7482	1	Muffler
46	3253-6	2	Washer-Lock
47	324-2	2	Screw-HH
48	9266934	2	Screw

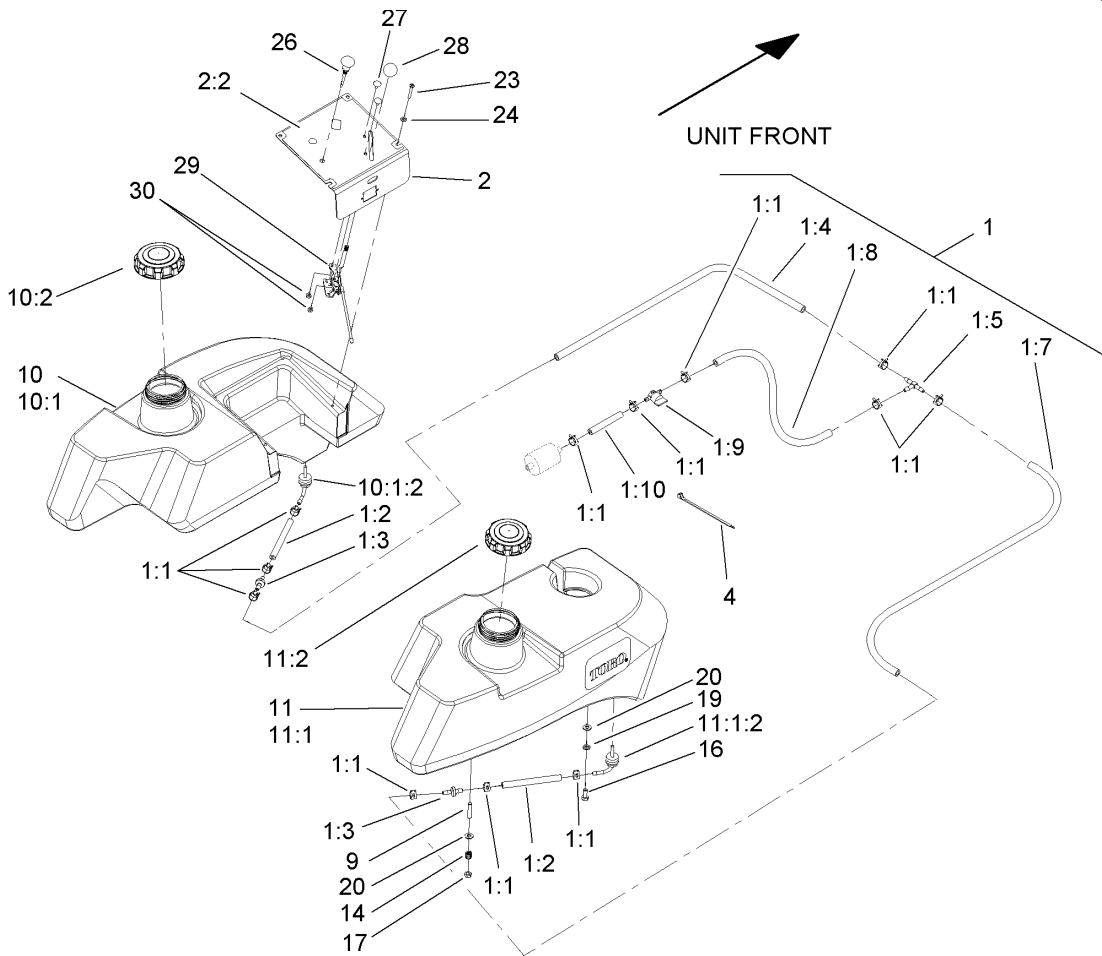

## Fuel Tank Assembly

Ref	Part No.	Qty.	Description
1	107-9285	1	Fuel Line ASM
1:1	1-303077	12	Clamp
1:2	109-0678	2	Hose-Fuel
1:3	99-5000	2	Valve-Check, Fuel
1:4	109-0305	1	Hose-Fuel
1:5	99-5005	1	Fitting-Tee, Barbed
1:7	109-0302	1	Hose-Fuel
1:8	110-5702	1	Hose-Fuel
1:9	1-603770	1	Valve-Fuel
1:10	109-0660	1	Hose-Fuel
2	110-3886	1	Control Panel ASM
2:2	110-5721	1	Decal-Panel, Control
4	1-303335	4	Tie-Plastic
9	1-633023	6	Stud
10	105-3644	1	LH Fuel Tank Kit ASM
② 10:1		1	LH Fuel Tank ASM
10:1:2	103-2605	1	Fitting-Fuel, Bulkhead
10:2	109-0346	1	Cap-Fuel, Gas
11	105-3643	1	RH Fuel Tank Kit ASM
② 11:1		1	RH Fuel Tank ASM
11:1:2	103-2605	1	Fitting-Fuel, Bulkhead
11:2	109-0346	1	Cap-Fuel, Gas
14	1-633349	6	Spring-Tank, Fuel
16	322-3	2	Screw-HH

Ref	Part No.	Qty.	Description
17	3296-47	6	Nut-Lock, NI
19	1-805005	2	Washer-Lock
20	3256-23	8	Washer-Flat
23	3251-1	4	Screw-PPH
24	1-303435	4	Washer-Spring
26	110-5720	1	Control-Choke, Push / Pull
27	1-807513	2	Bolt-CARR
28	1-603175	1	Knob-Ball
29	110-5717	1	Cable-Throttle
30	3296-2	2	Nut-Lock

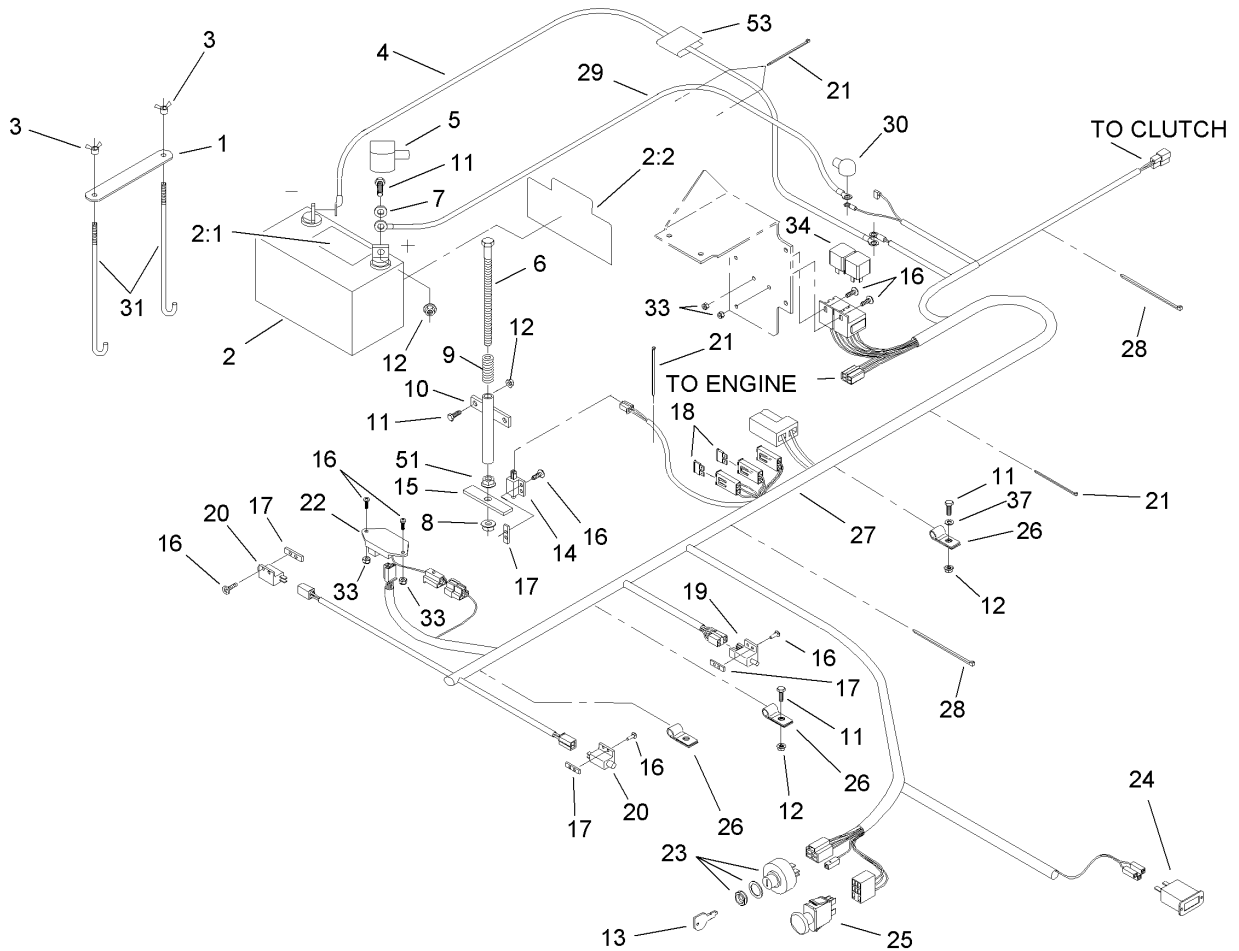

## Electrical Assembly

Ref	Part No.	Qty.	Description
1	107-9277-03	1	Strap-Holddown, Battery
2	105-1692	1	Battery
2:1	104-4163	1	Decal-Battery
2:2	104-4164	1	Decal-Battery
3	1-543792	2	Wingnut
4	1-633307	1	Wire-Ground
5	1-543391	1	Insulator-Battery
6	1-800282	1	Screw-HH
7	3256-2	2	Washer-Flat
8	3296-29	1	Nut-Lock, NI
9	1-523415	1	Spring-Switch, Seat
10	1-522424-03	1	Mount-Spring, Seat
11	321-4	6	Screw-HH
12	32128-33	6	Nut-HF
13	63-8360	2	Key-Ignition
14	1-513152	1	Switch-Closed, Normally
15	1-513180	1	Plate-Switch, Seat
16	3290-500	12	Screw-PPH
17	1-633181	4	Plate-Tapped
18	1-816001	2	Fuse-Blade Type, 20 Amp
19	1-633111	1	Switch
20	1-513051	2	Switch-Open, Normally
21	1-303287	5	Tie-Plastic
22	100-6186	1	Module-Delay, Seat

Ref	Part No.	Qty.	Description
23	103-0206	1	Switch-Starting, Key
24	1-513374	1	Meter-Hour
25	103-5221	1	Switch-PTO
26	1-633396	3	Clip-Loom
27	106-7497	1	Harness-Wire
28	1-303335	2	Tie-Plastic
29	1-523281	1	Wire-Starter
30	1-543393	1	Insulator-Solenoid
31	1-633651	2	Bolt-Holddown
33	3296-2	4	Nut-Lock
34	1-643275	2	Relay
37	3256-22	1	Washer-Flat
51	3217-6	1	Nut-Hex
53	107-9309	1	Decal-Instructions, Charging



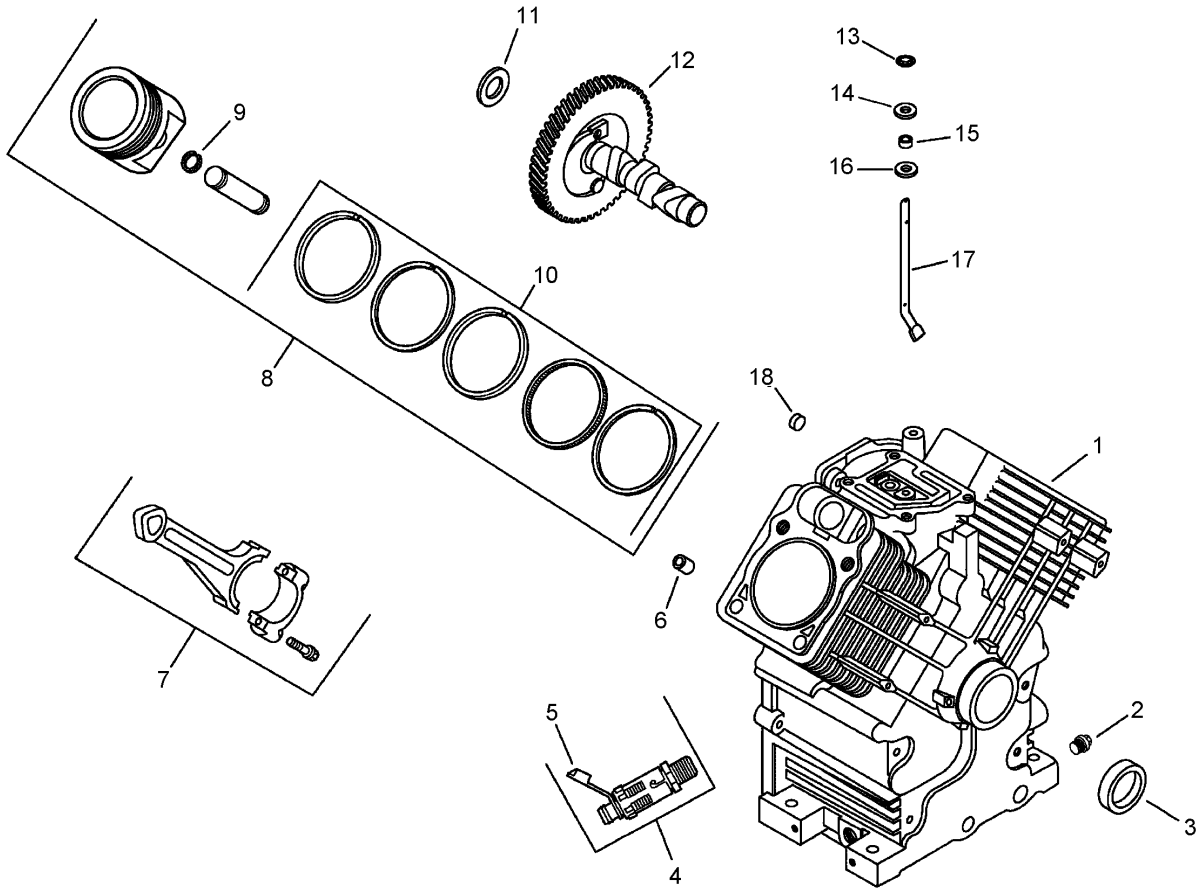

## Crankcase Assembly Kohler CH750-0010

Ref	Part No.	Qty.	Description
2 4 1		1	Crankcase
4 2	52 139 02-S	1	Plug-Pipe
4 3	24 032 01-S	1	Seal-Oil, Front
4 4	25 755 14-S	1	Valve-Drain, Oil (Includes 5)
4 5	25 173 14-S	1	Cap-Valve, Oil Drain
4 6	24 380 16-S	6	Pin-Locating
4 7	24 067 13-S	2	Rod-Connecting (STD)
4	24 067 14-S	2	Rod-Connecting (.25)
4 8	66 874 01-S	2	Piston W/Ring Set (STD) (Includes 9,10)
4	66 874 02-S	2	Piston W/Ring Set (.08)
4	66 874 03-S	2	Piston W/Ring Set (.25)
4	66 874 04-S	2	Piston W/Ring Set (.50)
4 9	24 018 01-S	4	Retainer-Pin, Piston
4 10	24 108 05-S	2	Ring Set (.25)
4	24 108 06-S	2	Ring Set (.25)
4	24 108 07-S	2	Ring Set (.50)
4 11	12 422 09-S	1	Shim-Camshaft, Red
4	12 422 13-S	1	Shim-Camshaft, Black
4	12 422 07-S	1	Shim-Camshaft, White
4	12 422 08-S	1	Shim-Camshaft, Blue
4	12 422 10-S	1	Shim-Camshaft, Yellow
4	12 422 11-S	1	Shim-Camshaft, Green
4	12 422 12-S	1	Shim-Camshaft, Gray

Ref	Part No.	Qty.	Description
4 12	24 012 18-S	1	Camshaft
4 13	24 018 09-S	1	Retainer-Ring
4 14	M-931010-S	1	Washer-Plain
4 15	28 032 09-S	1	Seal-Cross Shaft, Governor
4 16	24 468 15-S	1	Washer-Flat
4 17	24 144 38-S	1	Shaft-Cross, Governor
4 18	52 139 09-S	1	Plug-Cup

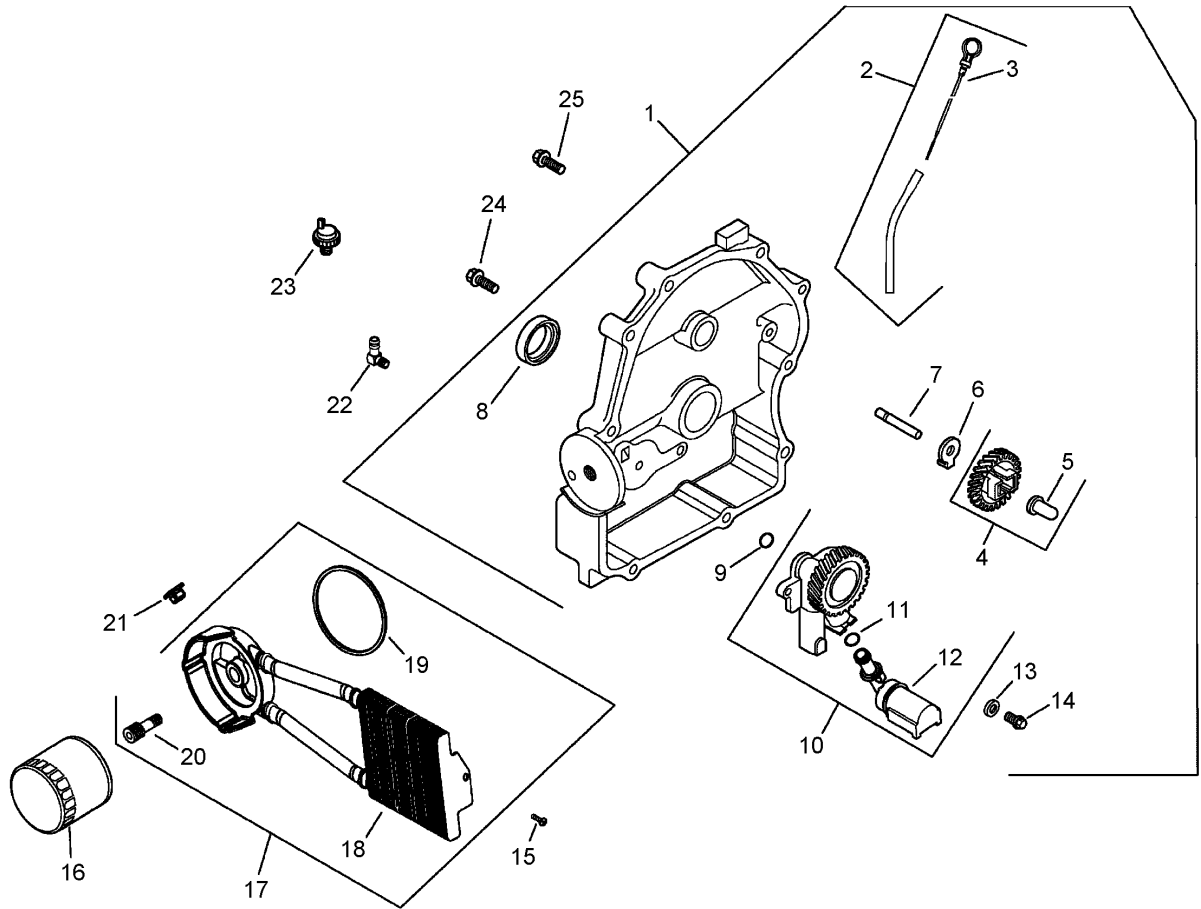

## Oil Pan and Lubrication Assembly Kohler CH750-0010

Ref	Part No.	Qty.	Description
1	24 009 163-S	1	Closure Plate ASM (Includes 2-14)
2	24 755 121-S	1	Dipstick Tube ASM (Includes 3)
3	24 038 10-S	1	Dipstick
4	24 043 12-S	1	Governor Gear Kit (Includes 5)
5	12 380 01-S	1	Pin-Regulating, Governor
6	24 448 02-S	1	Tab-Locking
7	12 144 02-S	1	Shaft-Gear, Governor
8	52 032 08-S	1	Seal-Oil
9	24 153 08-S	1	O-Ring
10	24 393 51-S	1	Oil Pump ASM (Includes 11,12)
11	24 381 04-S	1	Pick Up-Oil
12	24 153 01-S	1	O-Ring (Oil Pick Up)
13	M-631005-S	2	Washer-Plain (6Mm)
14	M-645025-S	2	Screw-HF (M6X1.0X25)
15	25 086 49-S	2	Screw-Tapping, 1/4-1X3/4
16	12 050 01-S	1	Filter-Oil
17	54 755 21-S	1	Oil Cooler Kit (Includes 18-20)
18	24 594 32-S	1	Cooler-Oil (Phenolic)
19	24 153 21-S	1	O-Ring
20	28 136 01-S	1	Nipple-Filter, Oil
21	24 100 01-S	2	Nut-Plastic
22	25 155 02-S	1	Connector
23	24 099 03-S	1	Switch-Pressure

Ref	Part No.	Qty.	Description
24	24 086 16-S	9	Screw-HF (M8X1.25X45)
25	24 086 17-S	1	Screw-HF (M8X1.25X45)

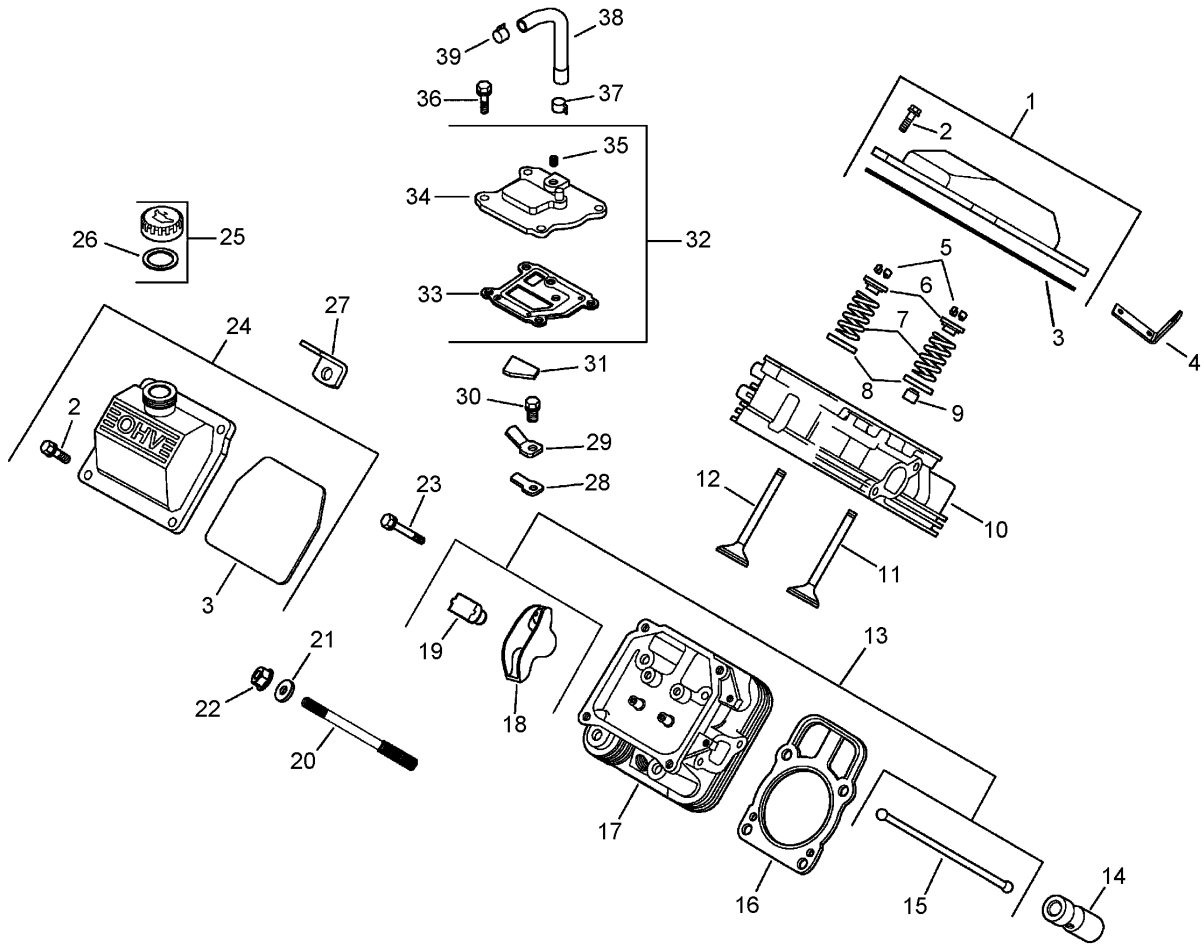

## Head, Valve and Breather Assembly Kohler CH750-0010

Ref	Part No.	Qty.	Description
❶	24 755 141-S	1	Plain Valve Cover Kit (Includes 2, 3)
❷	M-651030-S	4	Screw-HF (M6X1.0X30)
❸	24 153 28-S	1	O-Ring
❹	24 445 01-S	1	Strap-Lifting
❺	12 755 03-S	4	Retainer Kit
❻	12 173 01-S	2	Cap-Spring, Valve
❼	24 089 02-S	2	Spring-Valve
❽	235011-S	2	Retainer-Spring
❾	66 032 05-S	1	Seal-Stem, Valve
❿	24 318 99-S	1	Head ASM (No. 1 Cylinder)
⓫	24 017 01-S	1	Valve-Intake (STD)
⓫	24 017 02-S	1	Valve-Intake (.25)
⓬	24 016 01-S	1	Valve-Exhaust (STD)
⓬	24 016 02-S	1	Valve-Exhaust (.25)
⓭	24 755 66-S	1	Valve Train Kit (Includes 15, 18, 19)
⓮	25 351 04-S	4	Lifter-Valve
⓯	24 411 05-S	2	Rod-Push
⓰	24 841 03-S	2	Cylinder Head Gasket Kit (Includes 21, 22)
⓱	24 318 100-S	1	Head ASM (No. 2 Cylinder)
⓲	25 186 01-S	2	Arm-Rocker
⓳	24 599 01-S	2	Pivot-Arm, Rocker
⓴	24 072 09-S	8	Stud-Head, Cylinder

Ref	Part No.	Qty.	Description
⓴	24 468 16-S	8	Washer
⓴	24 100 10-S	8	Nut-HF (M8X1.25)
⓴	M-640034-S	2	Screw-HF (M6X1.0X34)
⓴	24 755 140-S	1	Oil Fill Valve Cover Kit (Includes 2, 3)
⓴	25 755 13-S	1	Oil Fill Cap ASM (Includes 26)
⓴	24 153 02-S	1	O-Ring
⓴	12 445 05-S	1	Strap-Lifting
⓴	24 402 03-S	1	Reed-Breather
⓴	66 018 04-S	1	Retainer-Reed, Breather
⓴	M-545010-S	1	Screw-HF (M5X0.8X10)
⓴	24 050 01-S	1	Filter-Breather
⓴	24 033 01-S	1	Breather Kit (Includes 33-35)
⓴	24 041 51-S	1	Gasket-Breather
⓴	24 096 86-S	1	Cover-Breather
⓴	25 139 60-S	1	Plug-Pipe, 1/8In Allen Head
⓴	M-645020-S	4	Screw-HF (M6X1.0X20)
⓴	25 237 14-S	1	Clamp
⓴	24 326 80-S	1	Hose-Breather
⓴	25 237 08-S	1	Clamp-Hose
❶	24 755 147-S	1	Cylinder Head Hardware Kit (Includes 5-9, 11, 12, 14, 18, 19, 23)

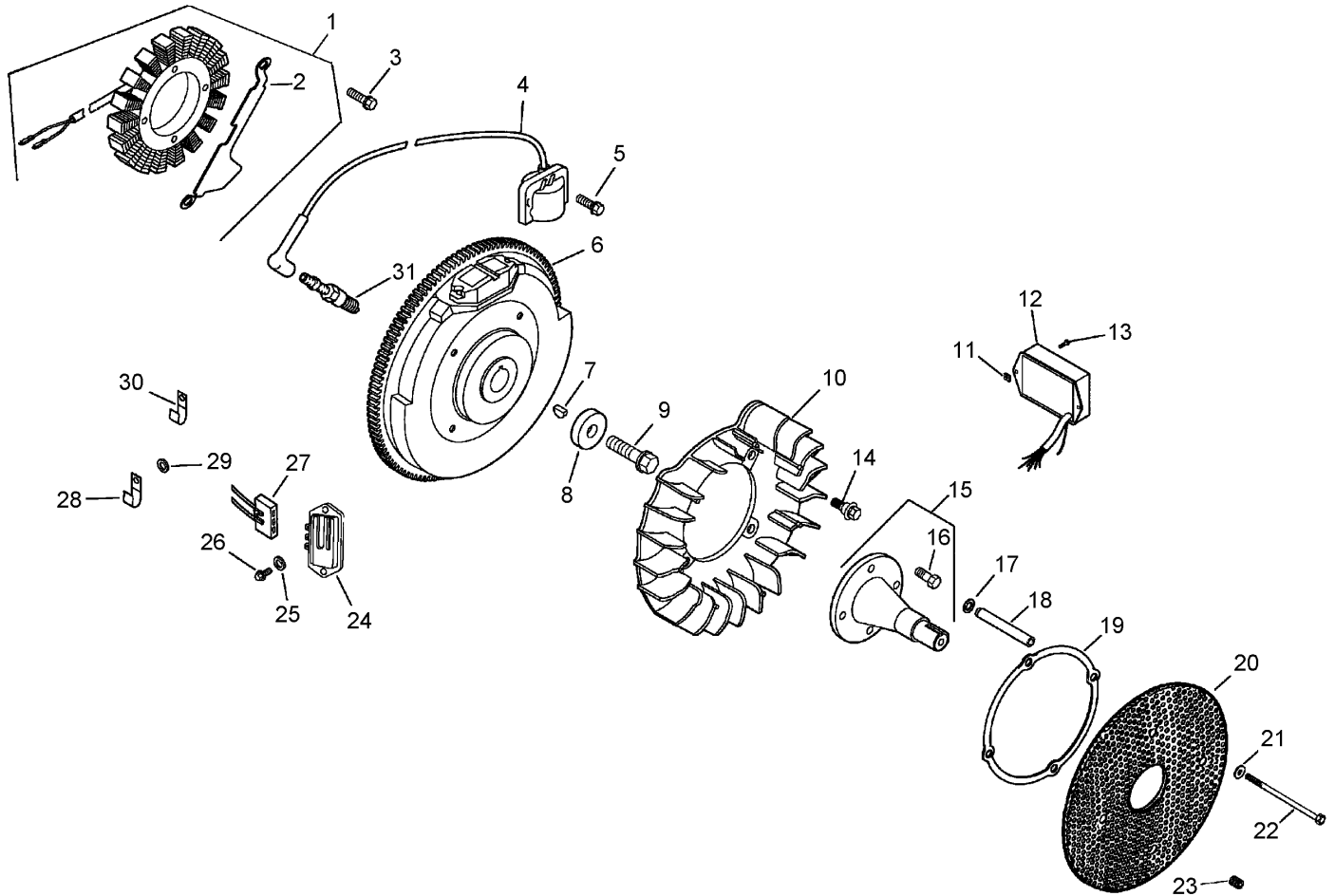

## Ignition and Electrical Assembly Kohler CH750-0010

Ref	Part No.	Qty.	Description
❶	54 755 09-S	1	Stator Kit (Includes 2)
❷	24 126 139-S	1	Bracket-Wire, Stator
❸	M-548025-S	2	Screw (M5X0.8X25)
❹	24 584 36-S	2	Module-Ignition
❺	M-545020-S	4	Screw-HF (M5X0.8X20)
❻	24 025 15-S	1	Flywheel
❼	X-42-15-S	1	Key
❽	12 468 03-S	1	Washer-Plain (3/8In)
❾	12 086 14-S	1	Screw-HF (M10X1.5X46)
❿	24 157 11-S	1	Fan
⓫	24 100 02-S	2	Nut-Plastic
⓬	24 584 38-S	1	Module-Advance, Speed
⓭	24 086 41-S	2	Screw
⓮	25 086 47-S	4	Bolt-Shoulder (M6X1.0X16)
⓯	24 755 08-S	1	Front Drive Shaft Kit (Includes 16)
⓰	M-839025-S	4	Screw-HF (M8X1.25X25)
⓱	X-25-53-S	4	Washer-Plain, 1/4In
⓲	24 112 14-S	4	Spacer
⓳	24 141 06-S	1	Ring-Support
⓴	24 162 22-S	1	Screen-Grass
⓵	24 468 11-S	4	Washer-Spring
⓶	M-603100-S	4	Screw-HH (M6X1.0X100)
⓷	25 086 43-S	1	Screw-Set
⓸	41 403 09-S	1	Rectifier-Regulator

Ref	Part No.	Qty.	Description
⓹	X-25-92-S	2	Washer-Plain
⓺	24 086 18-S	2	Screw-Head, Phillips
⓻	236602-S	1	Connector
⓼	12 154 01-S	1	Clamp-Line, Fuel
⓽	X-25-63-S	1	Washer-Plain (1/4In)
⓾	47 154 01-S	1	Clip-Cable
⓿	25 132 12-S	2	Spark Plug
⓿	24 176 98-S	1	Harness-Wiring
⓿	25 454 03-S	2	Tie-Cable
⓿	24 126 137-S	1	Bracket-Strap, Ground
⓿	25 468 07-S	1	Washer



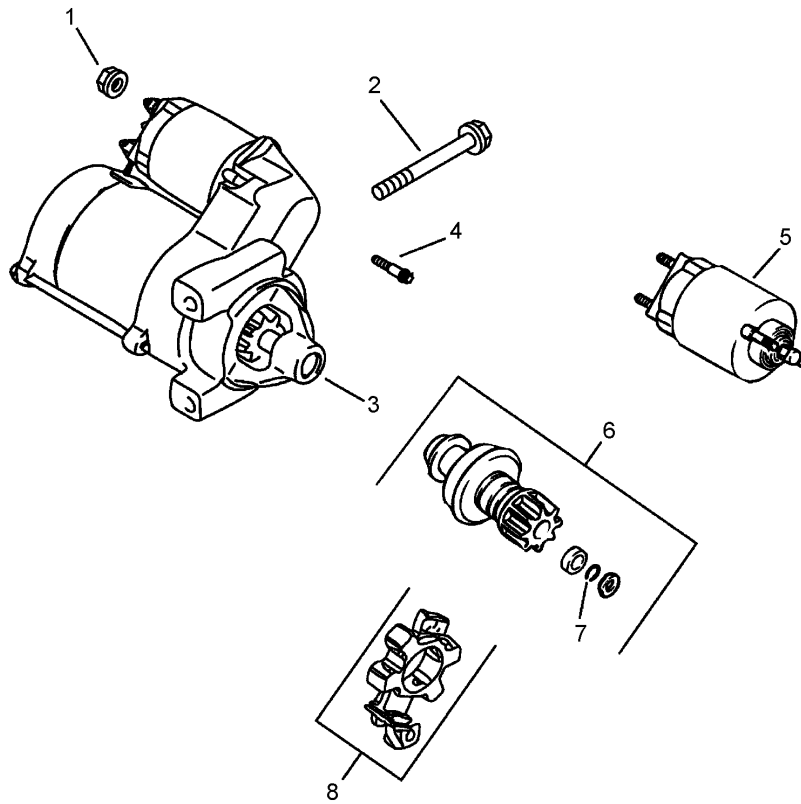

## Starting System Assembly Kohler CH750-0010

Ref	Part No.	Qty.	Description				
1	M-841080-S	1	Nut-HF (M8X1.25)				
2	M-839080-S	2	Screw-HF (M8X1.25X80)				
3	25 098 09-S	1	Starter ASM (Includes 4-8)				
4	25 086 113-S	3	Screw-Torx Head, External				
5	25 435 06-S	1	Solenoid Kit (Includes 4)				
6	25 755 33-S	1	Pinion Drive Kit (Includes 7)				
7	25 141 05-S	1	Ring				
8	25 221 01-S	1	Brush Kit				

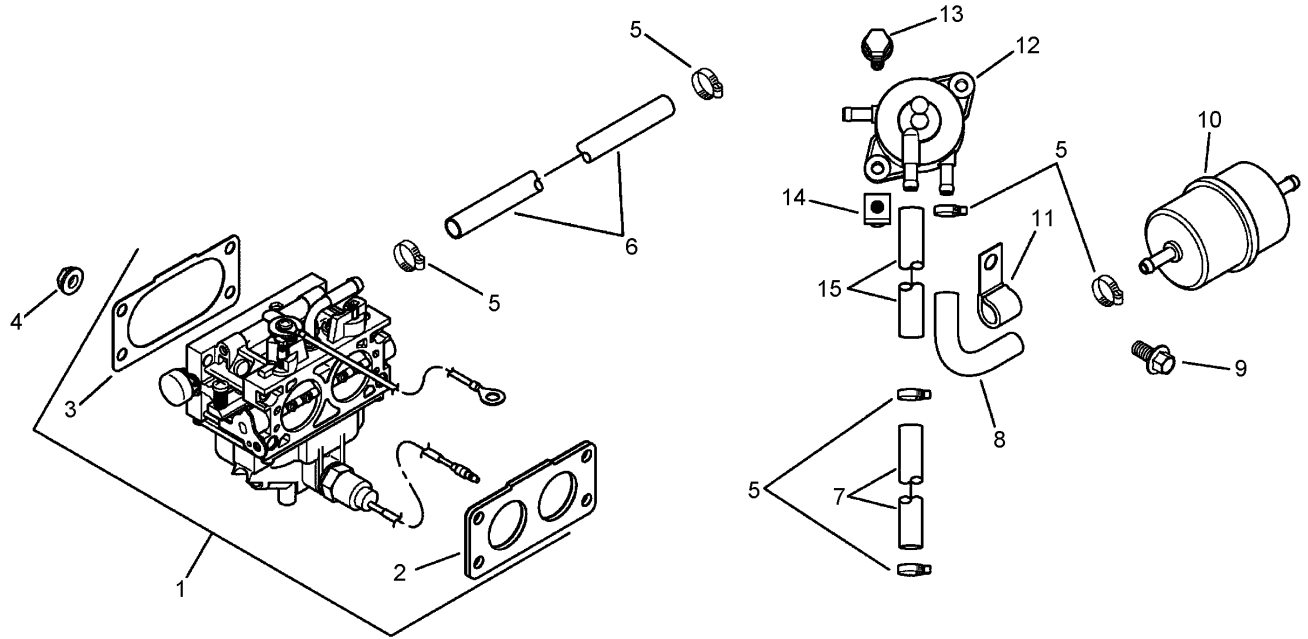

## Fuel System Assembly Kohler CH750-0010

Ref	Part No.	Qty.	Description
1	24 853 104-S	1	Carburetor Kit (Includes 2, 3)
2	24 041 60-S	1	Gasket-Manifold/Carburetor
3	24 041 58-S	1	Gasket-Carburetor/Elbow
4	M-641060-S	4	Nut-HF
5	25 237 14-S	6	Clamp
6	25 111 34-S	1	Line (Fuel Pump To Carburetor)
7	24 353 02-S	1	Line-Fuel
8	25 111 36-S	1	Line (Fuel Pump To Filter)
9	M-650012-S	1	Screw-HF (M6X1.0X12)
10	24 050 10-S	1	Filter-Fuel
11	47 154 01-S	1	Clip-Cable
12	24 393 16-S	1	Pump-Fuel
13	24 086 12-S	2	Screw
14	24 100 01-S	2	Nut-Plastic
15	24 431 02-S	1	Sleeve-Insulating
14	24 757 48-S	1	Service Choke Repair Kit
14	24 757 49-S	1	Float Kit
14	24 757 50-S	1	Solenoid Valve Kit
14	24 757 51-S	1	Overhaul Kit

--	--	--	--

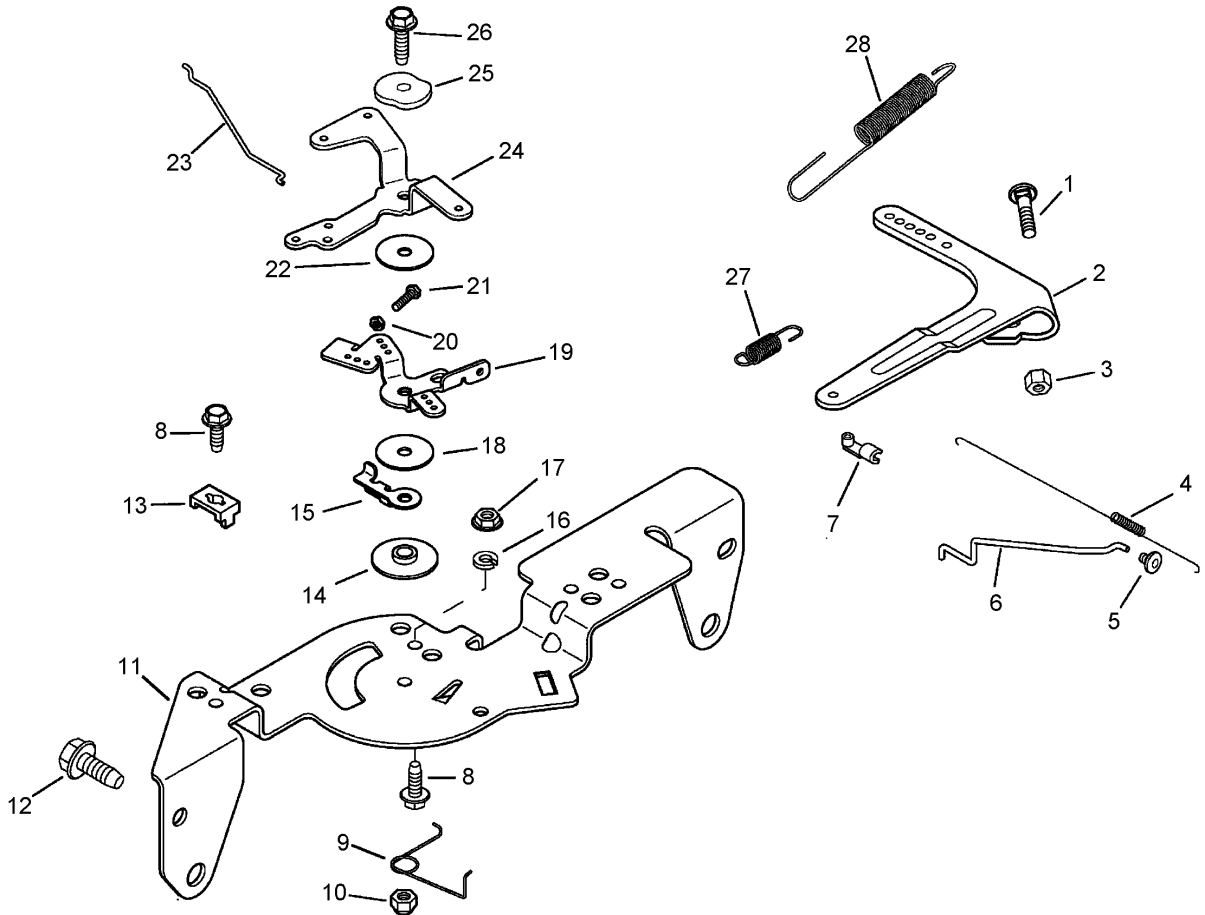

## Engine Control Assembly Kohler CH750-0010

Ref	Part No.	Qty.	Description
1	24 211 03-S	1	Bolt-Square Neck, Round Head
2	24 090 33-S	1	Lever-Governor
3	M-641060-S	1	Nut-HF
4	24 089 01-S	1	Spring-Linkage
5	25 158 08-S	1	Bushing-Retaining, Linkage
6	24 079 26-S	1	Linkage-Throttle
7	25 158 11-S	1	Bushing-Linkage
8	M-545016-S	3	Screw-HF (M5X0.8X16)
9	24 089 03-S	1	Spring-Return, Choke
10	M-547050-S	1	Nut-Lock, Hex (M5X0.8)
11	24 126 56-S	1	Bracket-Control
12	M-645016-S	4	Screw-HF (M6X1.0X16)
13	12 237 01-S	2	Clamp-Cable
14	24 112 27-S	1	Spacer Control ASM
15	24 090 47-S	1	Lever-Actuator, Throttle
16	X-20-1-S	1	Washer-Lock (1/4In)
17	M-541050-S	1	Nut-HF (M5X0.8)
18	24 468 20-S	1	Washer-Flat
19	24 090 03-S	1	Lever-Control, Throttle
20	M-446030-S	1	Nut-HF (M4X0.7)
21	M-401030-S	1	Screw (M4X0.7X30)
22	24 468 01-S	1	Washer-Plain
23	24 079 27-S	1	Linkage-Choke
24	24 090 05-S	1	Lever-Choke

Ref	Part No.	Qty.	Description
25	41 468 03-S	1	Washer
26	M-545020-S	1	Screw-HF (M5X0.8X20)
27	24 089 55-S	1	Spring-Idle, Governed
28	24 089 49-S	1	Spring-Governor

# Air Intake and Filtration Assembly Kohler CH750-0010

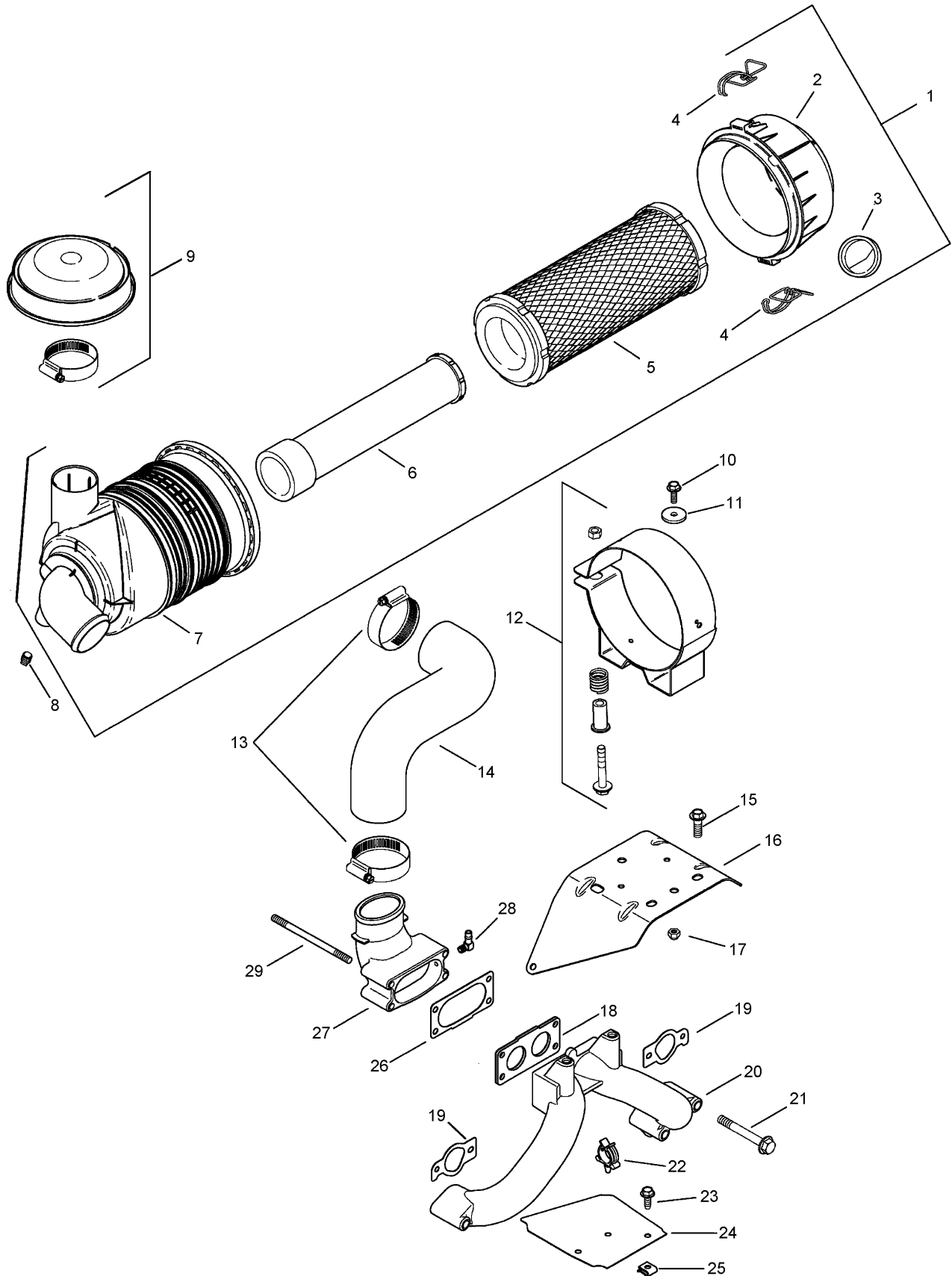

## Air Intake and Filtration Assembly Kohler CH750-0010

Ref	Part No.	Qty.	Description				
④1	25 048 07-S	1	Air Cleaner ASM (Includes 2-7)				
④2	25 096 06-S	1	Cover ASM				
④3	24 462 07-S	1	Valve-Ejector, Dust				
④4	25 154 05-S	2	Clip				
④5	25 083 01-S	1	Element-Air, Primary				
④6	25 083 04-S	1	Element-Air, Safety				
④7	25 081 01-S	1	Housing-Air Cleaner, Heavy Duty				
④8	25 139 20-S	1	Plug-Pipe				
④9	25 324 02-S	1	Hood-Cleaner, Air				
④10	M-639016-S	2	Screw-HF (M6X1.0X16)				
④11	X-25-73-S	2	Washer-Plain				
④12	25 126 02-S	1	Air Cleaner Bracket ASM				
④13	25 237 21-S	2	Clamp-Hose				
④14	24 326 81-S	1	Hose-Cleaner, Air				
④15	M-839020-S	2	Screw-HF				
④16	24 126 147-S	1	Bracket-Mounting, Air Cleaner				
④17	M-647060-S	2	Nut				
④18	24 041 60-S	1	Gasket-Manifold/Carburetor				
④19	24 041 01-S	2	Gasket-Manifold, Intake				
④20	24 164 87-S	1	Manifold-Intake (Includes 17, 18, 25)				
④21	25 086 84-S	4	Screw-HF (M6X1.0X55)				
④22	25 018 03-S	1	Retainer-Clip				
④23	M-645016-S	2	Screw-HF (M6X1.0X16)				
④24	24 314 48-S	1	Shield-Debris				
④25	25 154 02-S	2	Clip				
④26	24 041 58-S	1	Gasket-Carburetor/Elbow				
④27	24 054 17-S	1	Elbow-Air Cleaner (Includes 25)				
④28	25 155 38-S	2	Connector-Hose				
④29	M-629122-S	4	Stud-Carburetor				
①④	25 113 05-S	1	Decal-Sentry, Oil				
①④	25 113 27-S	1	Decal-Cleaner, Air				



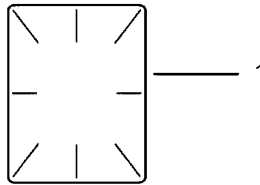

**OIL COOLER MAINTENANCE**

Oil cooler must be kept free of debris.

Inspect and clean every 25 hours, more frequently under severe conditions.

2

Artwork is representative.  
Actual labels may differ depending on model and specification number.

## Decal Assembly Kohler CH750-0010

Ref	Part No.	Qty.	Description
1	25 113 39-S	1	Decal-Lamination, Clear
2	24 113 25-S	1	Decal-Cooler, Oil

## NOTES

# NOTES

