



## Pro Sweep 5200 Turf Sweeper

Model No. 07065 - 260000201 and up.

### Parts Catalog

---

#### **Ordering Replacement Parts**

To order replacement parts, please supply the part number, the quantity, and the description of each part desired.

#### **Understanding Reference Numbers**

Each Identified part in an illustration has a reference number. The reference number for a part also appears in the parts list, along with other information about the part.

This catalog uses two special reference number formats, one to indicate parts in a service assembly and another to indicate the quantity of a given part in an illustration.

#### **Service Assembly Reference Numbers**

Parts in service assemblies have reference numbers in the form a:b. The a represents the reference number of the entire service assembly and the b represents a sequential number unique to each part within the service assembly.

For example, a wheel assembly might be identified by reference number 6, the tire by 6:1, the valve by 6:2, and the wheel by 6:3. When you order the assembly identified by reference number 6, you receive all parts identified by reference numbers 6:1, 6:2, and 6:3. However, you may also order any part individually. Reference numbers of this type appear in illustrations and in part lists.

#### **Reference Numbers Indicating Quantity**

In an illustration, if a reference number indicates more than one part, the reference number has the form nX y. The n represents the quantity of the part, the X is the multiplication symbol, and the y represents the reference number.

For example, in an illustration, the reference number 2X 37 means that two of the parts identified by reference number 37 are indicated.

# Contents

Description	Page	Description	Page
Main Frame and Axle Assembly	..... 3	Hopper Assembly	..... 13
Trailer Axle Assembly No. 107-1529	..... 4	Hopper Lid and Baffle Assembly	..... 14
Pitch Frame and Cylinder Assembly	..... 5	Hose Assembly	..... 15
Hydraulic Cylinder Assembly No. 107-1310	..... 6	Manifold Block Assembly No. 107-1400	..... 16
Saddle Frame Assembly	..... 7	Tongue Assembly	..... 17
Brush Housing Assembly	..... 8	Wire Harness Assembly	..... 18
Brush, Motor and Shield Assembly	..... 9	Remote Control Assembly No. 110-7520	..... 19
Hydraulic Motor Assembly No. 105-9455	..... 10	Hydraulic Fitting Assembly	..... 20
Brush Assembly No. 107-1452	..... 11	Control Box Mounting Assembly	..... 21
Roller Assembly	..... 12	Windrow Assembly	..... 22
		Attachments and Accessories List	..... 23

## Part Description Abbreviations

Part descriptions in this catalog may include the following abbreviations.

AR. .... as required	INC. .... incorporated
ASM. .... assembly	LH. .... left hand
BBC. .... blade brake clutch	NI. .... nylon insert
CARR. .... carriage	NPTF. .... national pipe thread fine
DEG. .... degrees	PFH. .... phillips flat head
EXT. .... external	PPH. .... phillips pan head
FH. .... flat head	PPHTF. .... phillips pan head thread forming
GA. .... gauge	PRH. .... phillips round head
HF. .... hex flange	PTH. .... phillips truss head
HH. .... hex head	PTO. .... power-take-off
HHF. .... hex head flange	RH. .... right hand
HHFTF. .... hex head flange thread forming	ROPS. .... roll-over-protection-system
HJ. .... hex jam	SFH. .... slotted fillister head
HLH. .... hex lag head	SHH. .... slotted hex head
HOC. .... height-of-cut	SHWH. .... slotted hex washer head
HSBH. .... hex socket button head	SPH. .... slotted pan head
HSFH. .... hex socket flat head	SQH. .... square head
HSH. .... hex socket head	SRH. .... slotted round head
HWH. .... hex washer head	STD. .... standard
HWHTF. .... hex washer head thread forming	TAP. .... self tapping
HYD. .... hydraulic	TTH. .... torx truss head

## Footnotes

❶ Not illustrated

❷ Not serviced separately

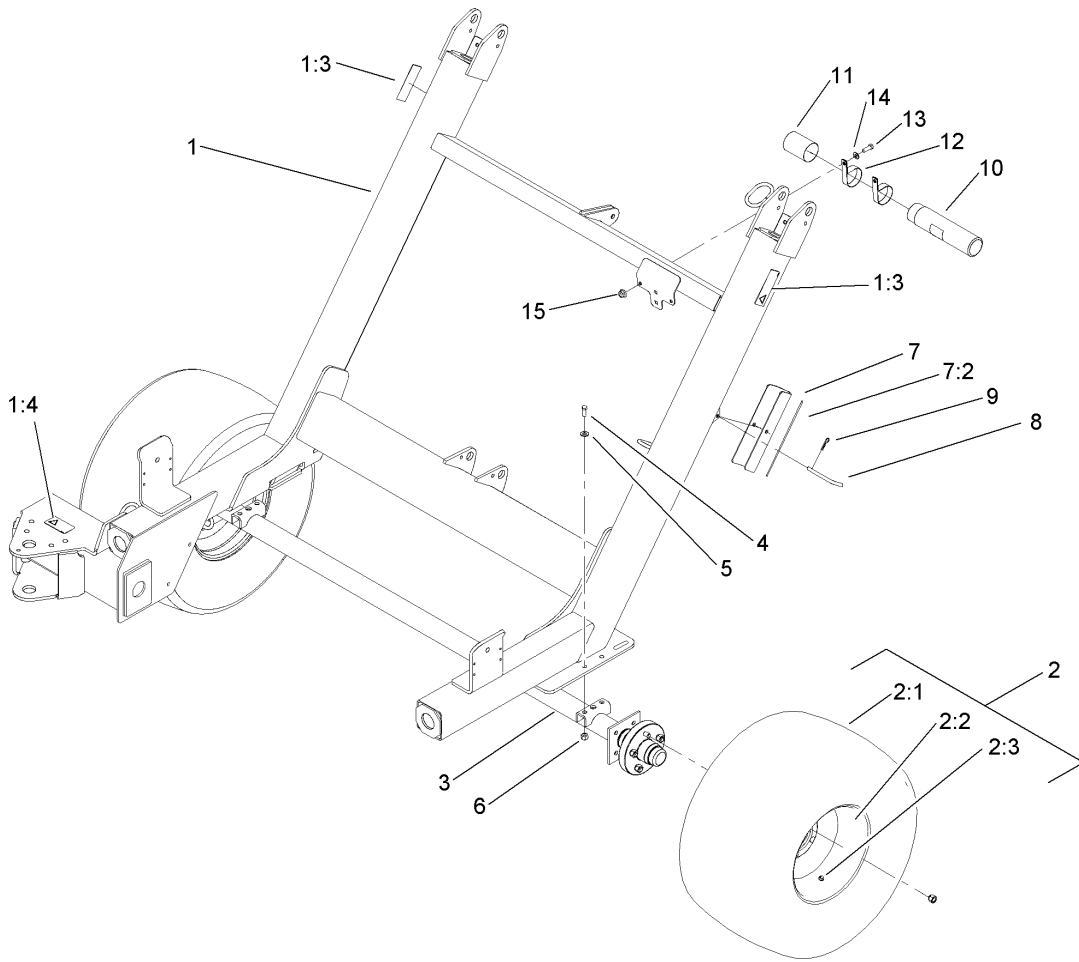

## Main Frame and Axle Assembly

Ref	Part No.	Qty.	Description
1	108-0776	1	Frame-Main
1:3	108-0865	2	Decal-Pinchpoint
1:4	108-0866	1	Decal-Pinchpoint
2	107-1459	2	Wheel And Tire ASM
2:1	93-6152	1	Tire
2:2	107-1461	1	Rim
2:3	232-24	1	Stem-Valve
3	107-1529	1	Trailer Axle ASM
4	324-5	4	Screw-HH
5	3256-25	8	Washer-Flat
6	3296-48	4	Nut-Lock, NI
7	108-0777	1	Stop-Cylinder
7:2	93-9852	1	Decal-Warning
8	63-7880	1	Pin-Latch, Brake
9	3290-250	1	Pin-Hair
10	104-7050	1	Housing-Manual
11	104-7048	1	Cap-Housing
12	2412-133	2	R-Clamp
13	323-6	2	Screw-HH
14	3256-24	2	Washer-Flat
15	104-8301	2	Nut-Flange, NI

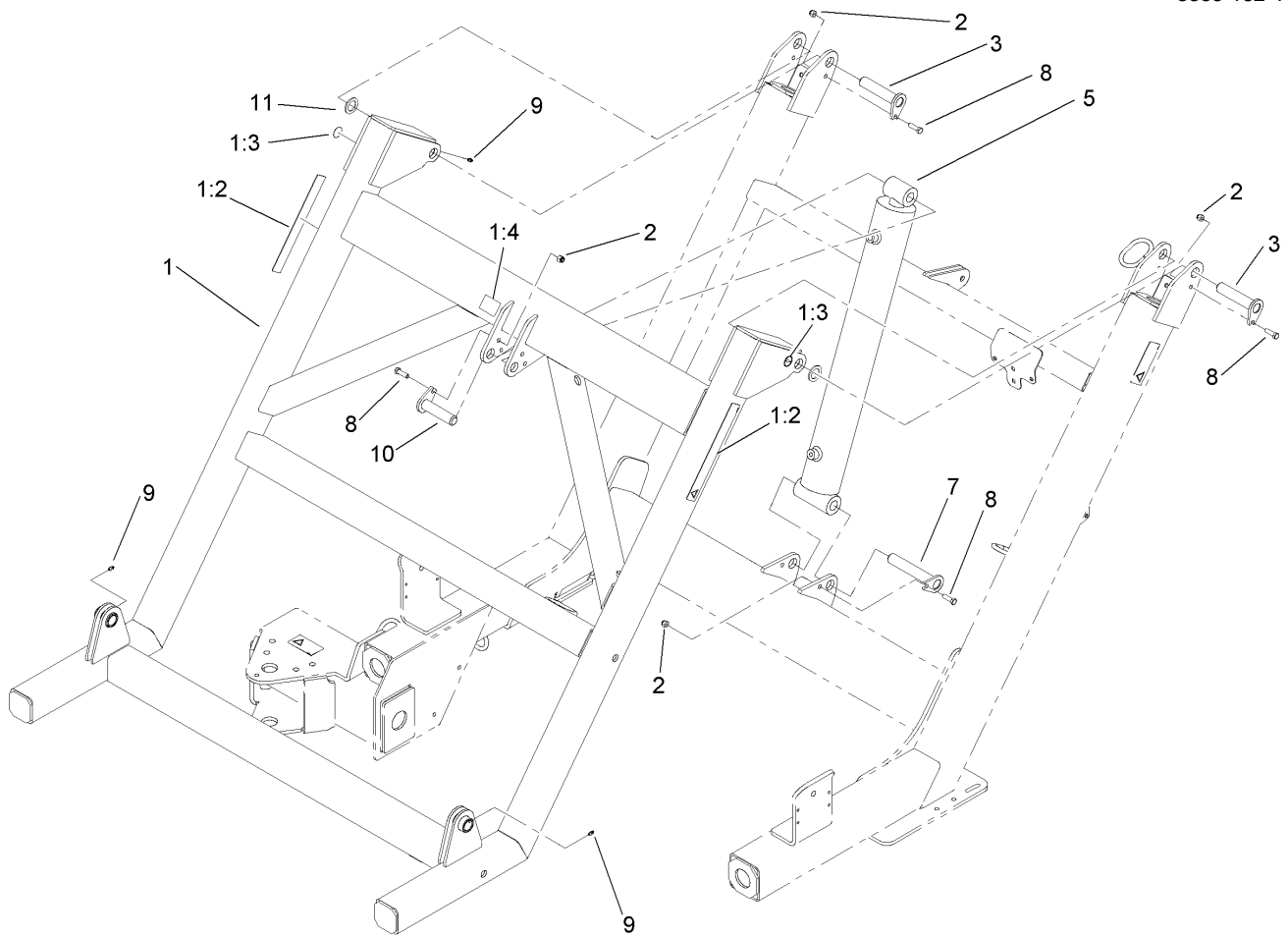

## Pitch Frame and Cylinder Assembly

Ref	Part No.	Qty.	Description
1	108-0778	1	Frame-Pitch
1:2	108-0863	2	Decal-Caution, Bystanders (Ce)
1:3	58-6520	2	Decal-Grease
1:4	93-9899	1	Decal-Warning
2	104-8301	4	Nut-Flange, NI
3	107-1258	2	Pin-Flag
5	107-1310	1	Cylinder-HYD
7	108-0669	1	Pin-Flag
8	323-7	4	Screw-HH
9	302-5	4	Fitting-Grease
10	108-0826	1	Pin-Flag
11	92-7845	2	Spacer-Hardened

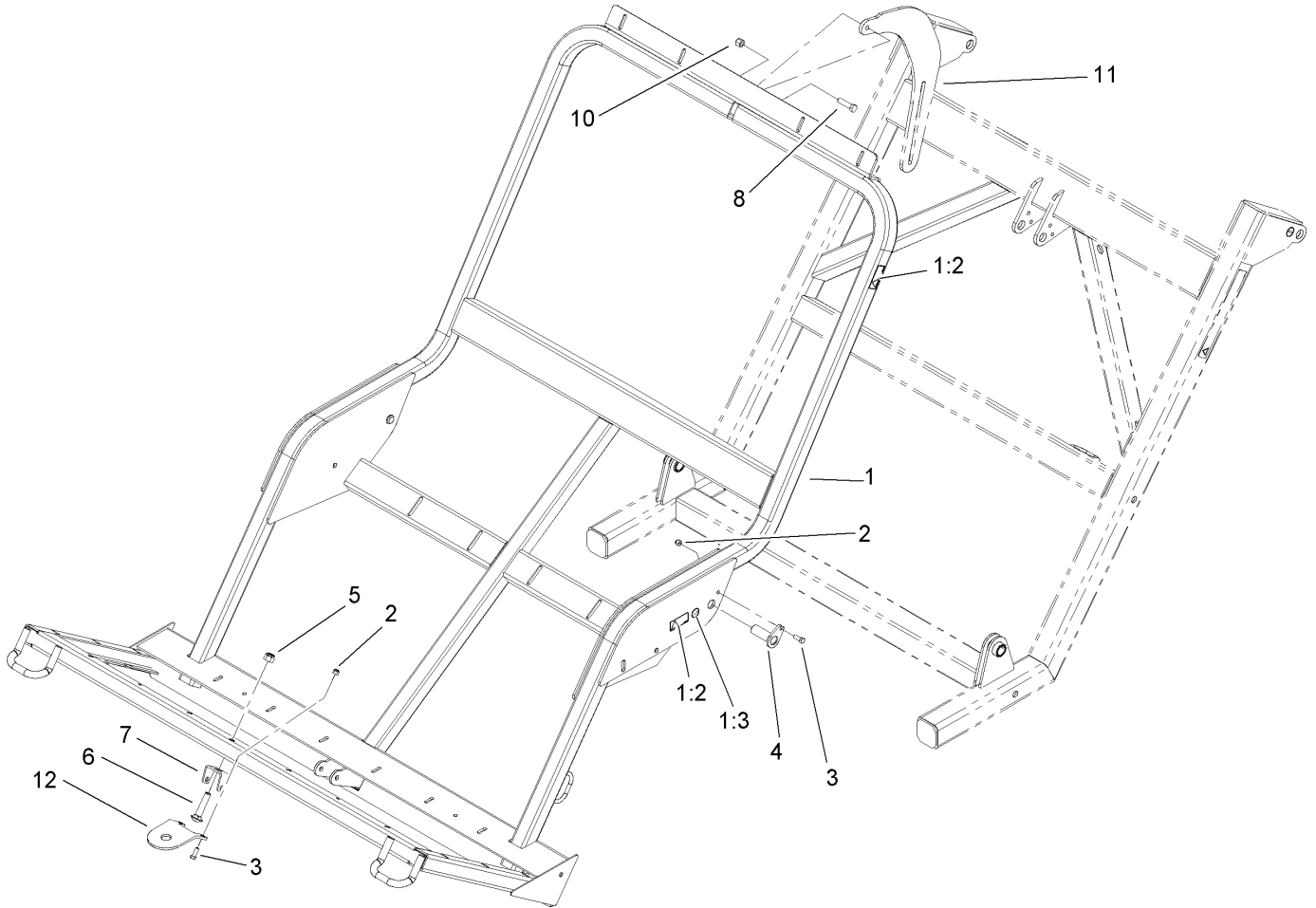

### Saddle Frame Assembly

Ref	Part No.	Qty.	Description				
1	108-0779	1	Saddle ASM				
1:2	108-0872	4	Decal-Warning				
1:3	58-6520	2	Decal-Grease				
2	104-8301	4	Nut-Flange, NI				
3	323-6	4	Screw-HH				
4	108-0657	2	Pin-Flag				
5	3296-53	1	Nut-Lock, NI				
6	3233-32	1	Bolt-Carriage				
7	107-1458-03	1	Pivot-Saddle				
8	325-7	2	Screw-HH				
10	3296-23	2	Nut-Lock, NI				
11	108-0759-01	1	Link				
12	107-1327-03	1	Plate-Hook, Tow				

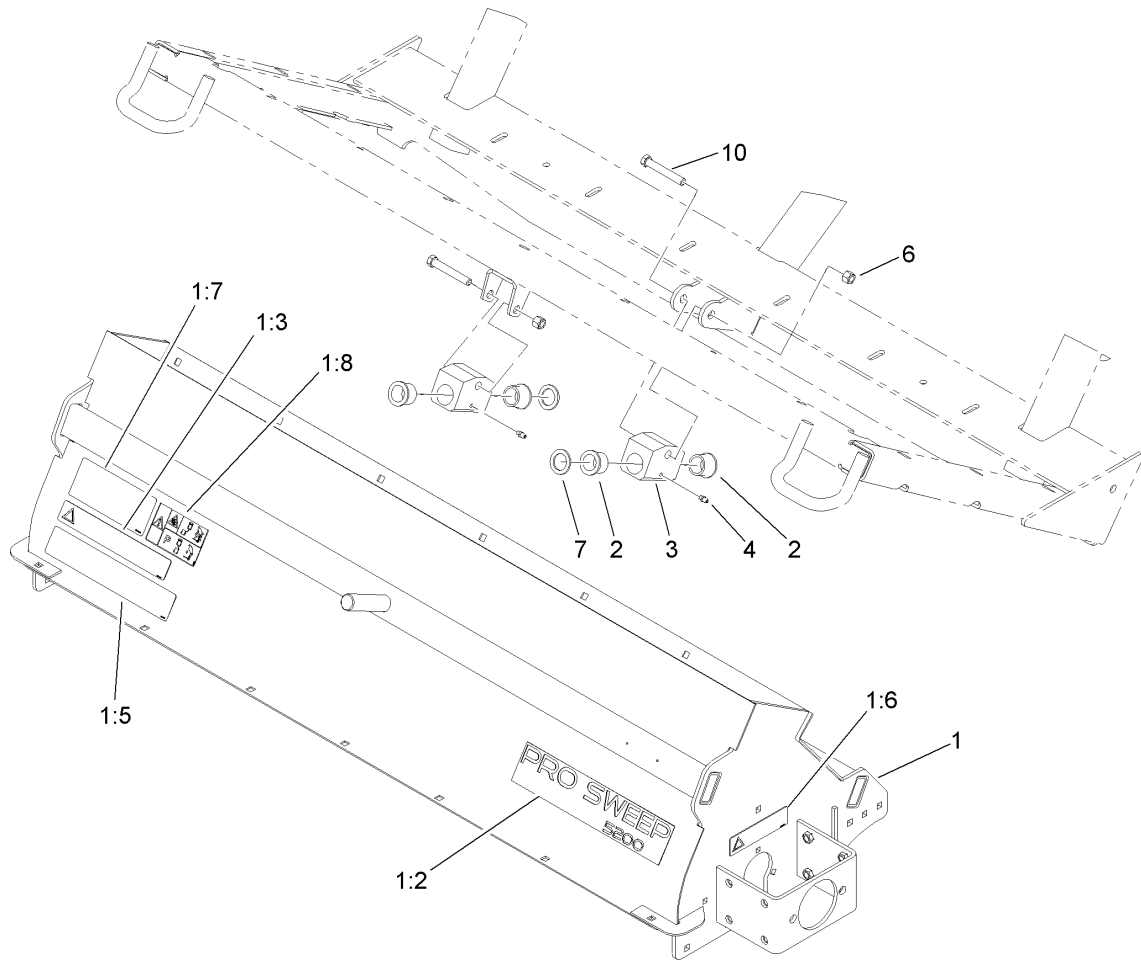

## Brush Housing Assembly

Ref	Part No.	Qty.	Description
1	108-0780	1	Brush Housing ASM
1:2	107-1453	1	Decal
1:3	108-0862	1	Decal-Warning, Shields
1:5	108-0868	1	Decal-Pinchpoint
1:6	108-0870	1	Decal-Warning, Shields
1:7	108-0873	1	Decal-Danger
1:8	110-7999	1	Decal-Warning, Offset Lift
2	94-8949	4	Bushing-Flange
3	107-1547	2	Mount-Pivot
4	302-5	2	Fitting-Grease
6	99-5107	2	Nut-Loc
7	3-8514	2	Washer-Thrust
10	325-14	2	Screw-HH

--	--	--	--

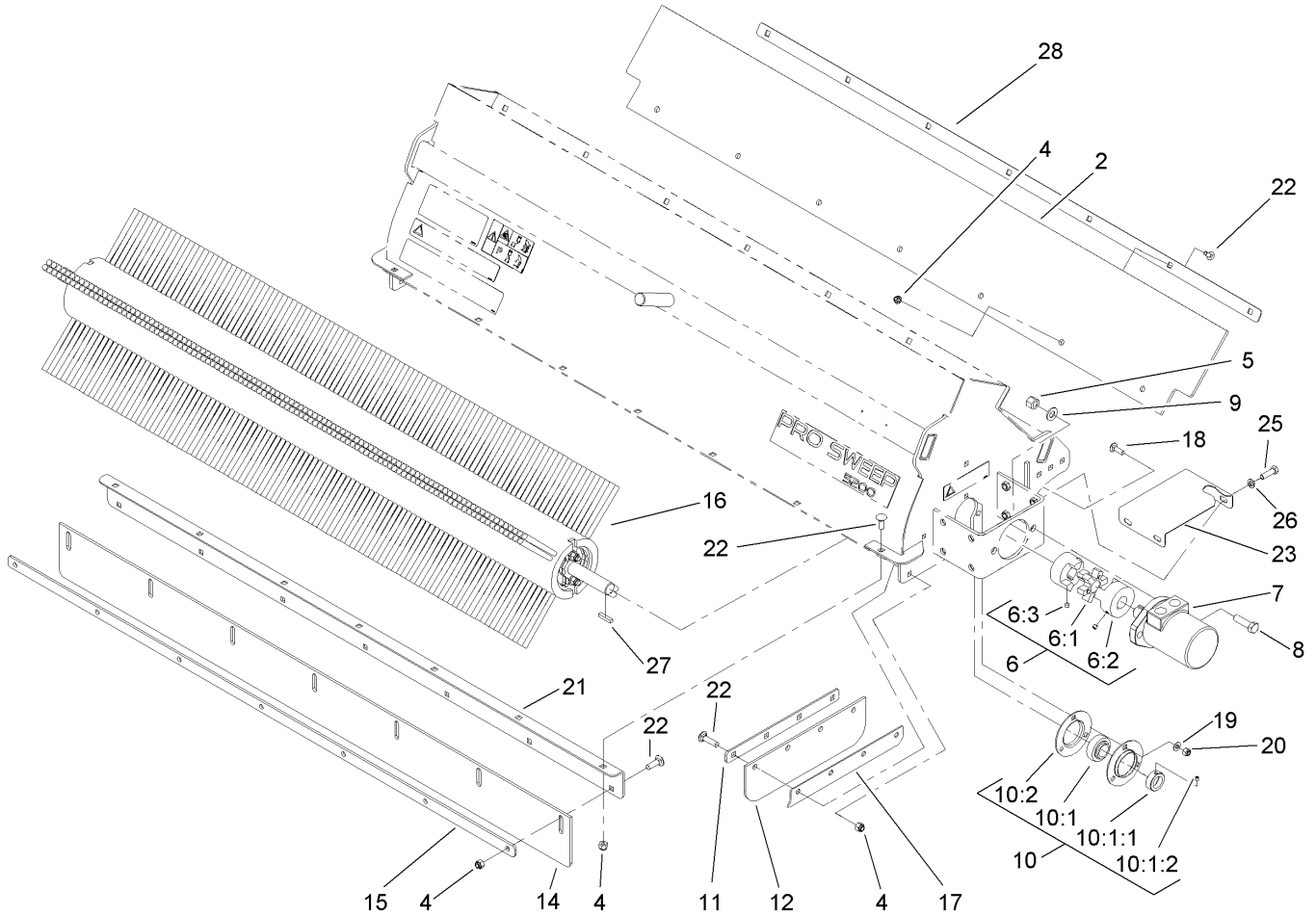

## Brush, Motor and Shield Assembly

Ref	Part No.	Qty.	Description
2	108-0686	1	Shield-Rubber, Top
4	104-8301	29	Nut-Flange, NI
5	3296-23	2	Nut-Lock, NI
6	108-0760	1	Coupling-Jaw, Stock
6:1	108-0761	1	Spider-Coupling
6:2	108-0762	2	Coupling-Jaw
6:3	3246-2	4	Screw-Set, HSH
7	105-9455	1	Motor
8	325-7	2	Screw-HH
9	3256-26	2	Washer-Flat
10	107-1471	2	Bearing-Flange, 3-Bolt
10:1	107-1472	1	Bearing
10:1:1	251-77	1	Lockcollar-Bearing
10:1:2	3245-35	1	Screw-Set
10:2	107-1474	2	Flange-3 Bolt
11	108-0668-03	2	Plate-Skirt, Side
12	108-0683	2	Shield-Rubber, Side
14	107-1302	1	Shield-Rubber, Front
15	108-0667-03	1	Plate-Skirt, Front
16	107-1452	1	Brush ASM
17	107-1439-03	2	Plate-Angle
18	3230-2	6	Bolt-CARR
19	3256-23	6	Washer-Flat
20	3296-29	6	Nut-Lock, NI

Ref	Part No.	Qty.	Description
21	107-1280-01	1	Angle-Front
22	3231-25	29	Screw-CARR
23	108-0781	2	Cover-Coupler
25	323-6	8	Screw-HH
26	3253-21	8	Washer-Lock
27	13-2840	1	Key-Square
28	108-0844-03	1	Plate-Shield, Top

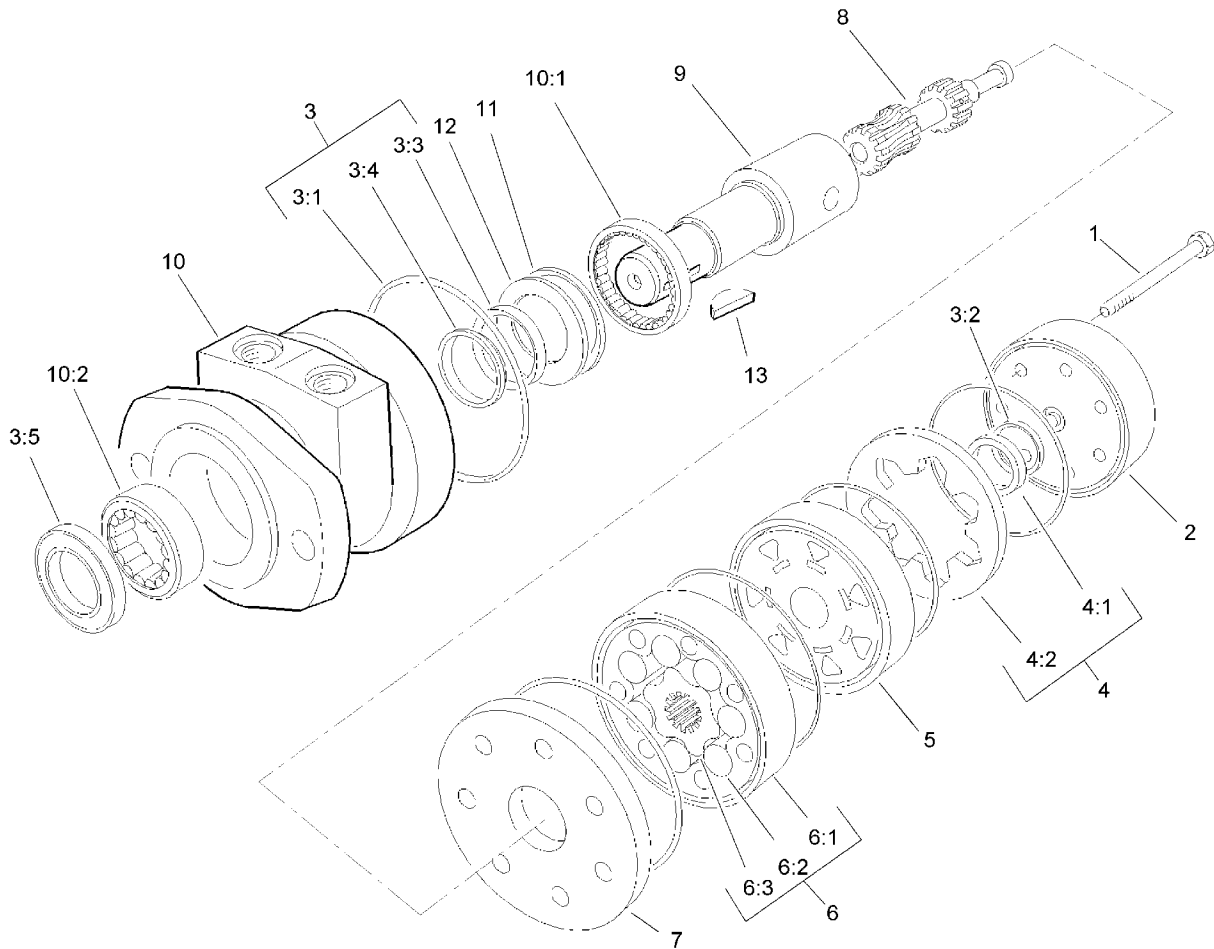

## Hydraulic Motor Assembly No. 105-9455

Ref	Part No.	Qty.	Description
1	322-33	5	Screw-HH
2	106-1981	1	Cover-End
3	106-1989	1	Seal Kit
②3:1		6	Seal-Ring
②3:2		1	Seal-Commutator
②3:3		1	Seal-Dirt And Water
②3:4		1	Washer-Backup
②3:5		1	Seal-Shaft
①②3:6		1	Ring-Back Up
4	106-1982	1	Commutator ASM
②4:1		1	Commutator
②4:2		1	Ring-Commutator
5	106-1983	1	Manifold
6	106-1984	1	Rotor Set
②6:1		1	Stator
②6:2		7	Vane
②6:3		1	Rotor
7	106-1985	1	Plate-Wear
8	106-1986	1	Link-Drive
9	106-1987	1	Shaft-Coupling
10	106-1988	1	Housing ASM
②10:1		1	Bearing
②10:2		1	Bearing
②11		1	Bearing-Thrust

Ref	Part No.	Qty.	Description
②12		1	Washer-Thrust
13	106-1990	1	Key-Woodruff





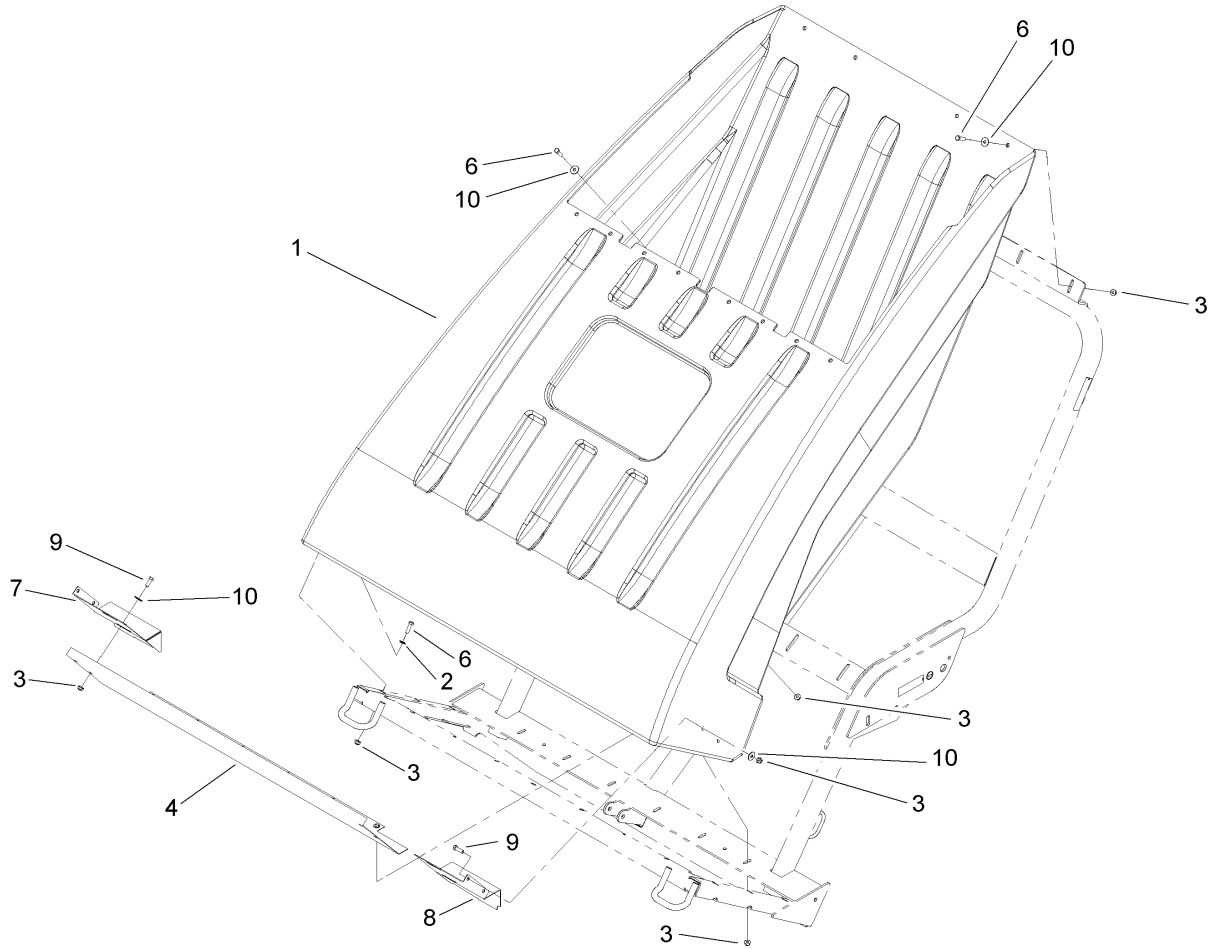

### Hopper Assembly

Ref	Part No.	Qty.	Description
1	107-1272	1	Hopper-Dump
2	3256-24	13	Washer-Flat
3	104-8301	34	Nut-Flange, NI
4	107-1225-03	1	Baffle-Hopper
6	323-7	21	Screw-HH
7	107-1462-03	1	Plate-Side, Baffle LH
8	107-1442-03	1	Plate-Side, Baffle RH
9	323-6	8	Screw-HH
10	3256-35	13	Washer-Flat

--	--	--	--



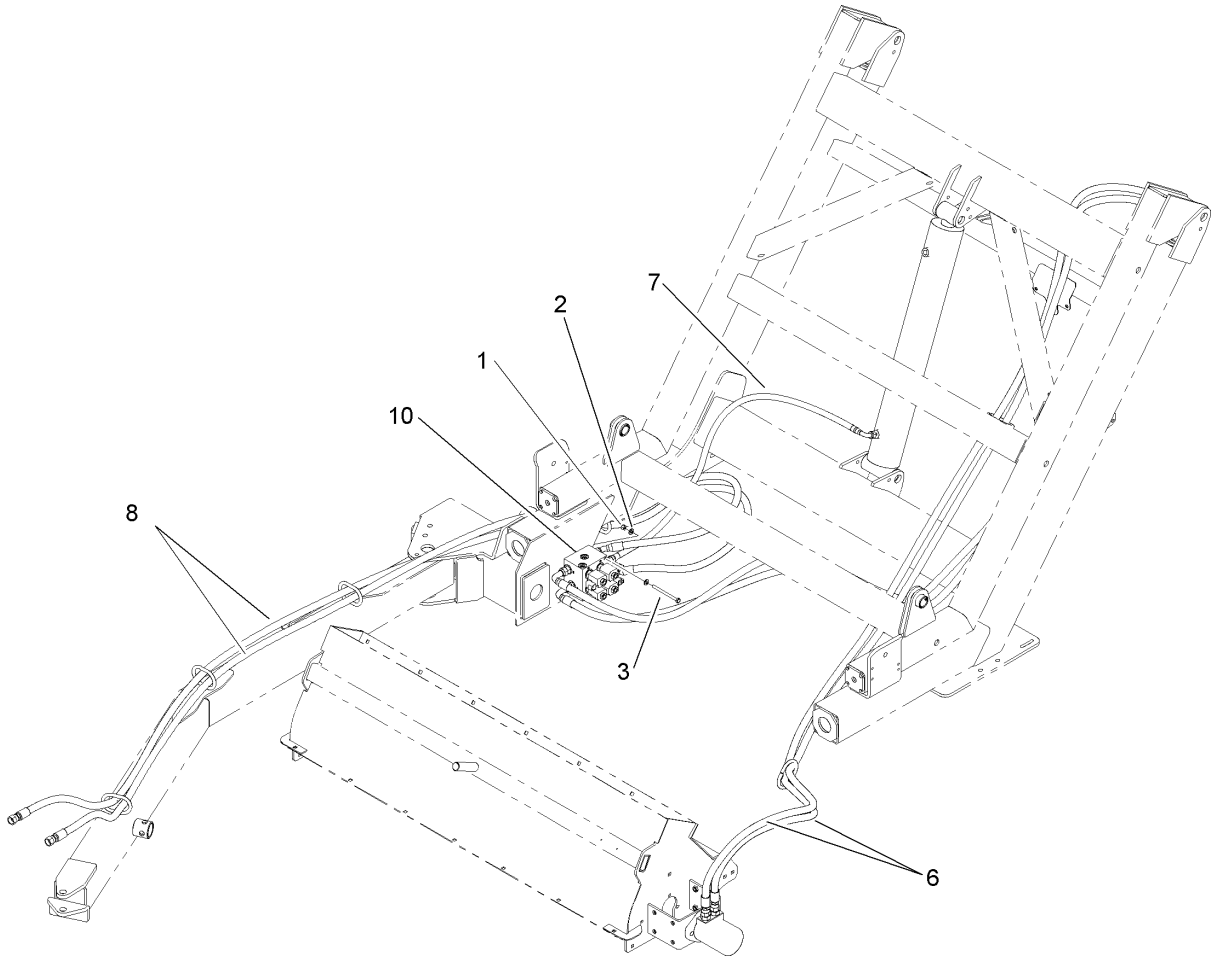

### Hose Assembly

Ref	Part No.	Qty.	Description
1	3296-29	2	Nut-Lock, NI
2	3256-23	4	Washer-Flat
3	322-19	2	Screw-HH
6	107-1394	2	HYD Hose ASM
7	107-1396	1	HYD Hose ASM
8	107-1395	2	HYD Hose ASM
10	107-1400	1	Block-Manifold

--	--	--	--

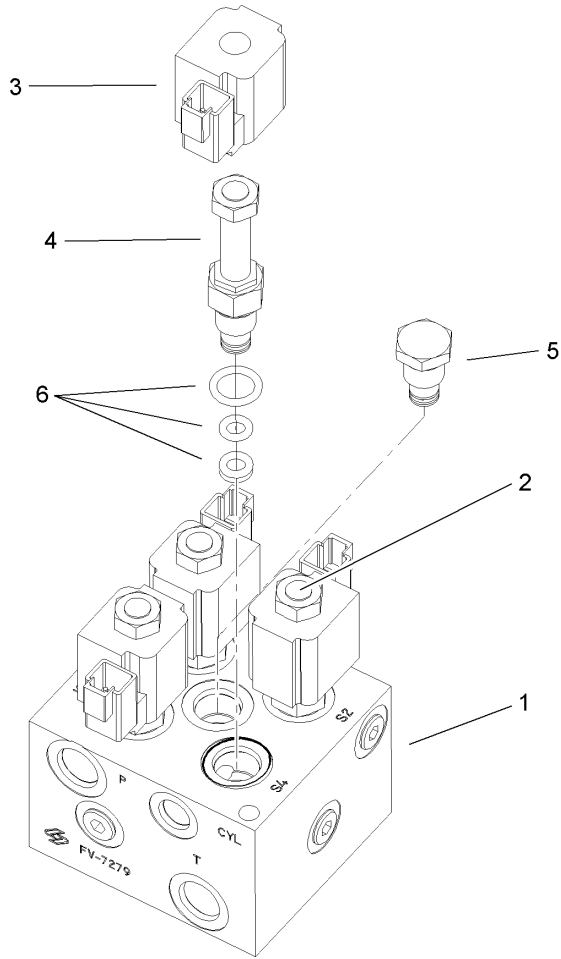

### Manifold Block Assembly No. 107-1400

Ref	Part No.	Qty.	Description
① 1		1	Valve Body
2	108-2884	1	Valve-Solenoid
3	108-2885	4	Receptacle-Deutsch, 12 Vdc
4	108-2886	3	Valve-Solenoid
5	108-2887	1	Valve-Check
6	95-1232	4	Valve Seal Kit









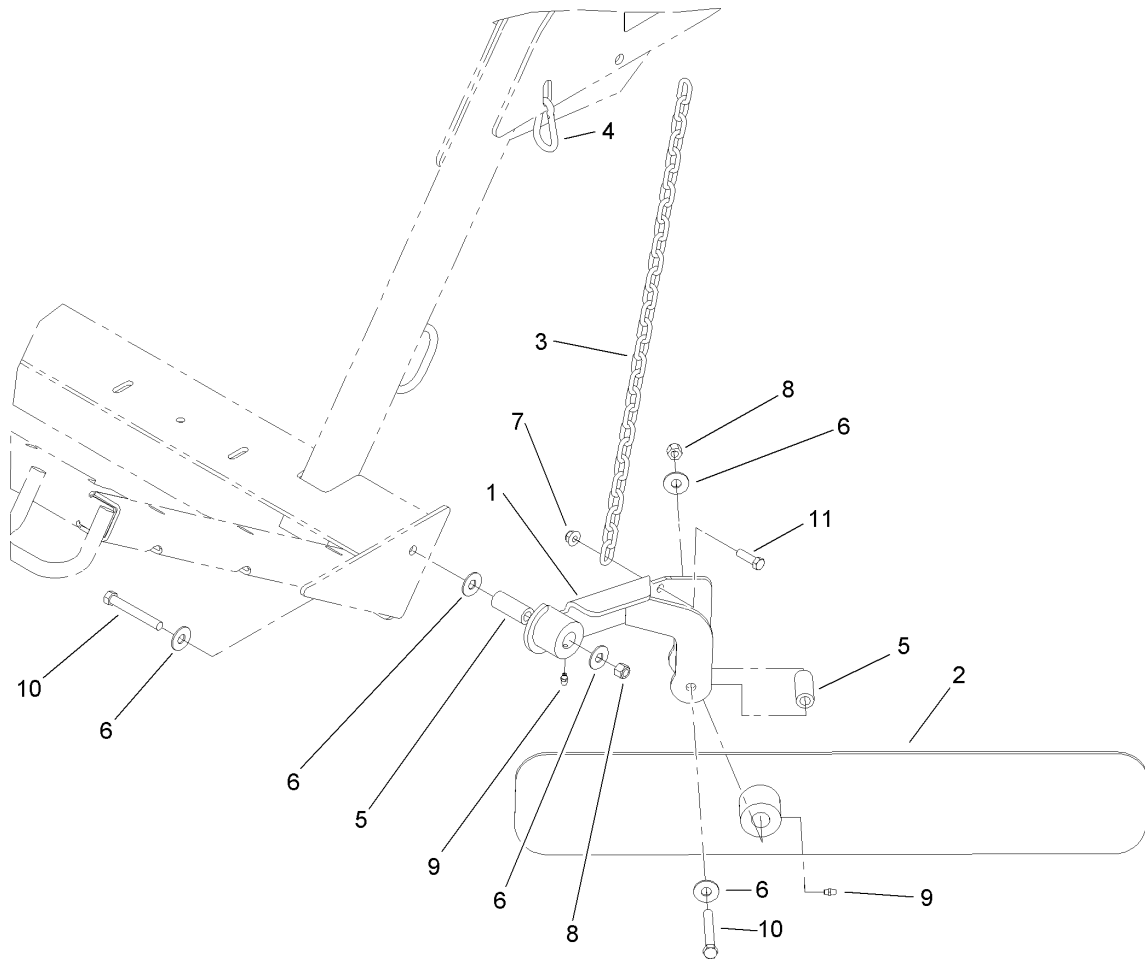

## Windrow Assembly

Ref	Part No.	Qty.	Description
1	107-1506-01	1	Arm ASM
2	108-0836-01	1	Windrow Blade ASM
3	SV139-00	1	Chain-Link
4	107-1507	1	Link-Snap
5	104-0958	2	Spacer-Windrow
6	3256-5	5	Washer-Flat
7	104-8301	1	Nut-Flange, NI
8	3296-48	2	Nut-Lock, NI
9	302-5	2	Fitting-Grease
10	324-13	2	Screw-HH
11	323-7	1	Screw-HH

--	--	--	--

# Attachments and Accessories

## For 07065 - Pro Sweep 5200 Turf Sweeper

Product Name	Model/Part
Brake Kit .....	07086
Windrow Kit .....	07087
Electric Offset Arm .....	07088
Jack ASM .....	106-9699
Wheel Scraper Kit .....	107-1370
Slow-Moving Vehicle Sign Kit .....	107-1372
Side Mirror Kit .....	107-8048
Pin-Hitch, Pointed .....	13-6200
Rear View Mirror Kit .....	92-2670

