



Commercial Walk-Behind Mower Fixed Deck, Pistol Grip, Hydro Drive with 36in TURBO FORCE® Cutting Unit

Model No. 30984 - 260000001 and up.

Parts Catalog

Ordering Replacement Parts

To order replacement parts, please supply the part number, the quantity, and the description of each part desired.

Understanding Reference Numbers

Each Identified part in an illustration has a reference number. The reference number for a part also appears in the parts list, along with other information about the part.

This catalog uses two special reference number formats, one to indicate parts in a service assembly and another to indicate the quantity of a given part in an illustration.

Service Assembly Reference Numbers

Parts in service assemblies have reference numbers in the form a:b. The a represents the reference number of the entire service assembly and the b represents a sequential number unique to each part within the service assembly.

For example, a wheel assembly might be identified by reference number 6, the tire by 6:1, the valve by 6:2, and the wheel by 6:3. When you order the assembly identified by reference number 6, you receive all parts identified by reference numbers 6:1, 6:2, and 6:3. However, you may also order any part individually. Reference numbers of this type appear in illustrations and in part lists.

Reference Numbers Indicating Quantity

In an illustration, if a reference number indicates more than one part, the reference number has the form nX y. The n represents the quantity of the part, the X is the multiplication symbol, and the y represents the reference number.

For example, in an illustration, the reference number 2X 37 means that two of the parts identified by reference number 37 are indicated.

Contents

Description	Page	Description	Page
Engine and Fuel Tank Assembly 3	Valve and Camshaft Assembly Kawasaki Model FH430V-AS25 22
Drive Assembly 4	Lubrication Equipment Assembly Kawasaki Model FH430V-AS25 23
Parking Brake Assembly 6	Cooling Equipment Assembly Kawasaki Model FH430V-AS25 24
Frame and Wheel Assembly 7	Electric Equipment Assembly Kawasaki Model FH430V-AS25 25
Hydraulic Assembly 8	Control Equipment Assembly Kawasaki Model FH430V-AS25 26
Hydraulic Pump Assembly No. 106-5490 9	Carburetor Assembly Kawasaki Model FH430V-AS25 27
Pivot and Linkage Assembly 10	Air Filter and Muffler Assembly Kawasaki Model FH430V-AS25 28
Handle and Control Assembly 11	Fuel Tank and Fuel Valve Assembly Kawasaki Model FH430V-AS25 29
Control panel Assembly No. 110-6907 13	Starter Assembly Kawasaki Model FH430V-AS25 30
Deck Assembly 14	Label Assembly Kawasaki Model FH430V-AS25 31
Deck Decal Assembly No. 110-4907 15		
Deflector Assembly No. 110-0790 16		
Sheave, Spindle and Blade Assembly 17		
Idler Assembly 18		
Castor Assembly 19		
Cylinder and Crankcase Assembly Kawasaki Model FH430V-AS25 20		
Piston and Crankshaft Assembly Kawasaki Model FH430V-AS25 21		

Part Description Abbreviations

Part descriptions in this catalog may include the following abbreviations.

AR. as required	INC. incorporated
ASM. assembly	LH. left hand
BBC. blade brake clutch	NI. nylon insert
CARR. carriage	NPTF. national pipe thread fine
DEG. degrees	PFH. phillips flat head
EXT. external	PPH. phillips pan head
FH. flat head	PPHTF. phillips pan head thread forming
GA. gauge	PRH. phillips round head
HF. hex flange	PTH. phillips truss head
HH. hex head	PTO. power-take-off
HHF. hex head flange	RH. right hand
HHFTF. hex head flange thread forming	ROPS. roll-over-protection-system
HJ. hex jam	SFH. slotted fillister head
HLH. hex lag head	SHH. slotted hex head
HOC. height-of-cut	SHWH. slotted hex washer head
HSBH. hex socket button head	SPH. slotted pan head
HSFH. hex socket flat head	SQH. square head
HSH. hex socket head	SRH. slotted round head
HWH. hex washer head	STD. standard
HWHTF. hex washer head thread forming	TAP. self tapping
HYD. hydraulic	TTH. torx truss head

Footnotes

- ❶ Not illustrated
- ❷ Not serviced separately
- ❸ Obtain from your local Kawasaki dealer

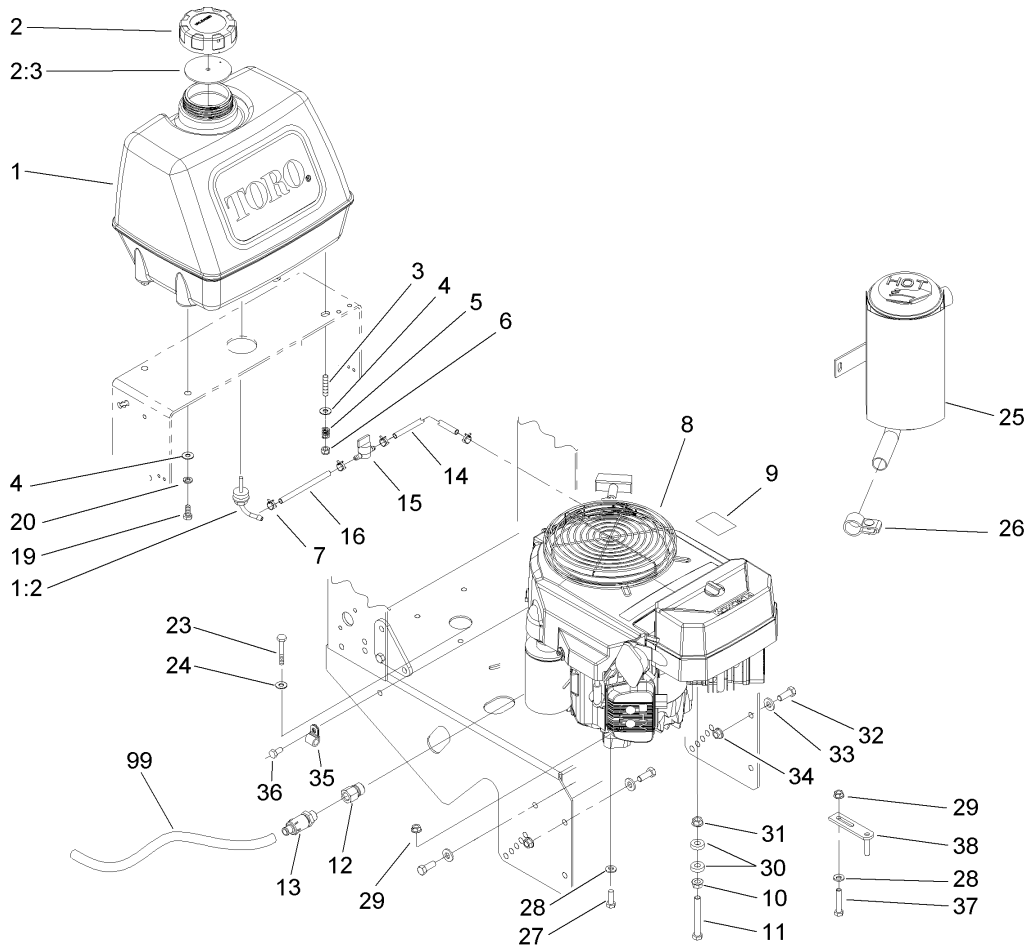

Engine and Fuel Tank Assembly

Ref	Part No.	Qty.	Description
1	106-0730	1	Fuel Tank ASM
1:2	103-2605	1	Fitting-Fuel, Bulkhead
2	88-3980	1	Gas Cap ASM
2:3	88-4010	1	Gasket-Cap, Gas
3	1-633023	2	Stud
4	3256-23	4	Washer-Flat
5	1-633349	2	Spring-Tank, Fuel
6	3296-47	2	Nut-Lock, NI
7	1-303077	4	Clamp
8		1	Engine-Kawasaki, FH430V-As25
9	106-0699	1	Decal-Warning, Hot Surfaces
10	32128-21	1	Nut-HF
11	323-14	1	Screw-HH
12	103-1966	1	Adapter
13	92-6877	1	Valve-Drain, Oil
14	109-0293	1	Hose-Fuel
15	1-603770	1	Valve-Fuel
16	109-0306	1	Hose-Fuel
19	322-3	2	Screw-HH
20	1-805005	2	Washer-Lock
23	33113-016	1	Screw-HH
24	1-805004	1	Washer-Lock
25	100-6467	1	Muffler
26	103-5465	1	Clamp-Muffler

Ref	Part No.	Qty.	Description
27	322-7	3	Screw-HH
28	1-303334	4	Washer-Spring
29	32128-20	4	Nut-HF
30	5-0652	2	Spacer
31	3296-39	1	Nut-Lock, NI
32	323-6	8	Screw-HH
33	98-5975	8	Washer-Belleville
34	3290-357	8	Nut-HHF, Whiz
35	1-413510	1	Clip-Loom
36	33114-016	1	Screw-HH
37	322-9	1	Screw-HH
38	1-322110	1	Guide-Belt
99	103-1964	1	Hose-Drain, Oil

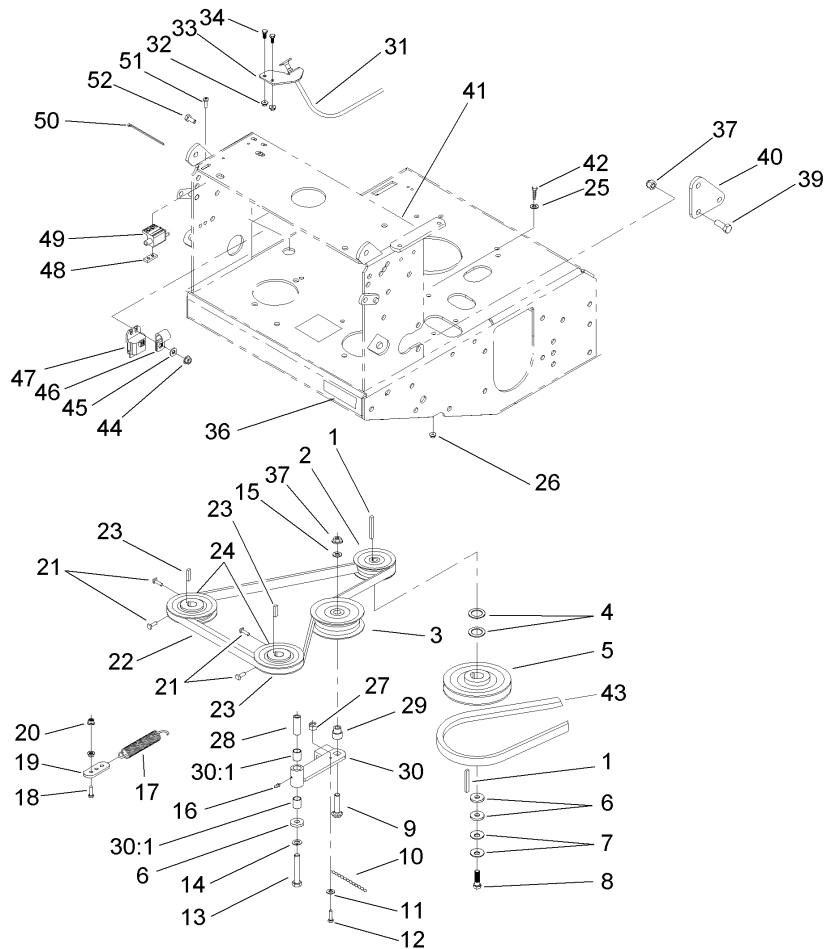

Drive Assembly

Ref	Part No.	Qty.	Description
1	1-807259	2	Key
2	1-653035	1	Pulley
3	1-603843	1	Pulley-Idler
4	1-523157	2	Washer-Spacer, 14 GA
5	110-4891	1	Pulley ASM
6	1-373034	3	Washer
7	1-603610	2	Washer-Spring
8	3212-6	1	Screw-HH
9	3231-6	1	Screw-CARR
10	1-323365	1	Chain-Link, Twist
11	3256-14	1	Washer-Flat
12	1-809069	1	Screw-Cap Socket Head
13	323-12	1	Screw-HH
14	1-373034	1	Washer
15	5-0652	1	Spacer
16	302-19	1	Fitting-Grease
17	1-603402	1	Spring-Extension
18	322-5	1	Screw-HH
19	1-603801	1	Anchor-Spring
20	32128-20	2	Nut-HF
21	1-803050	4	Screw-Set
22	106-2740	1	V-Belt-Drive, Hydro
23	1-807272	2	Key
24	1-413010	2	Sheave W/Hub

Ref	Part No.	Qty.	Description
25	3256-24	1	Washer-Flat
26	3290-357	1	Nut-HHF, Whiz
27	3296-2	1	Nut-Lock
28	1-603044	1	Bushing
29	1-603496	1	Bushing-Idler
30	1-602521	1	Idler Arm ASM
30:1	103-4681	2	Sleeve-Bearing
31	103-1796	1	Cable-Choke
32	32128-33	2	Nut-HF
33	103-1797-01	1	Bracket-Cable, Choke
34	321-3	2	Screw-HH
36	98-0776	1	Decal-Caution
37	3296-39	3	Nut-Lock, NI
39	323-6	2	Screw-HH
40	1-413497	1	Bellcrank
41	95-2814	1	Decal-Shut Off, Fuel
42	323-7	1	Screw-HH
43	108-6644	1	Belt-V
44	3296-42	1	Nut-Lock, NI
45	3256-22	1	Washer-Flat
46	1-603727	1	Clip-Loom
47	1-323430	1	Module-Interlock
48	1-633181	1	Plate-Tapped
49	1-513051	1	Switch-Open, Normally

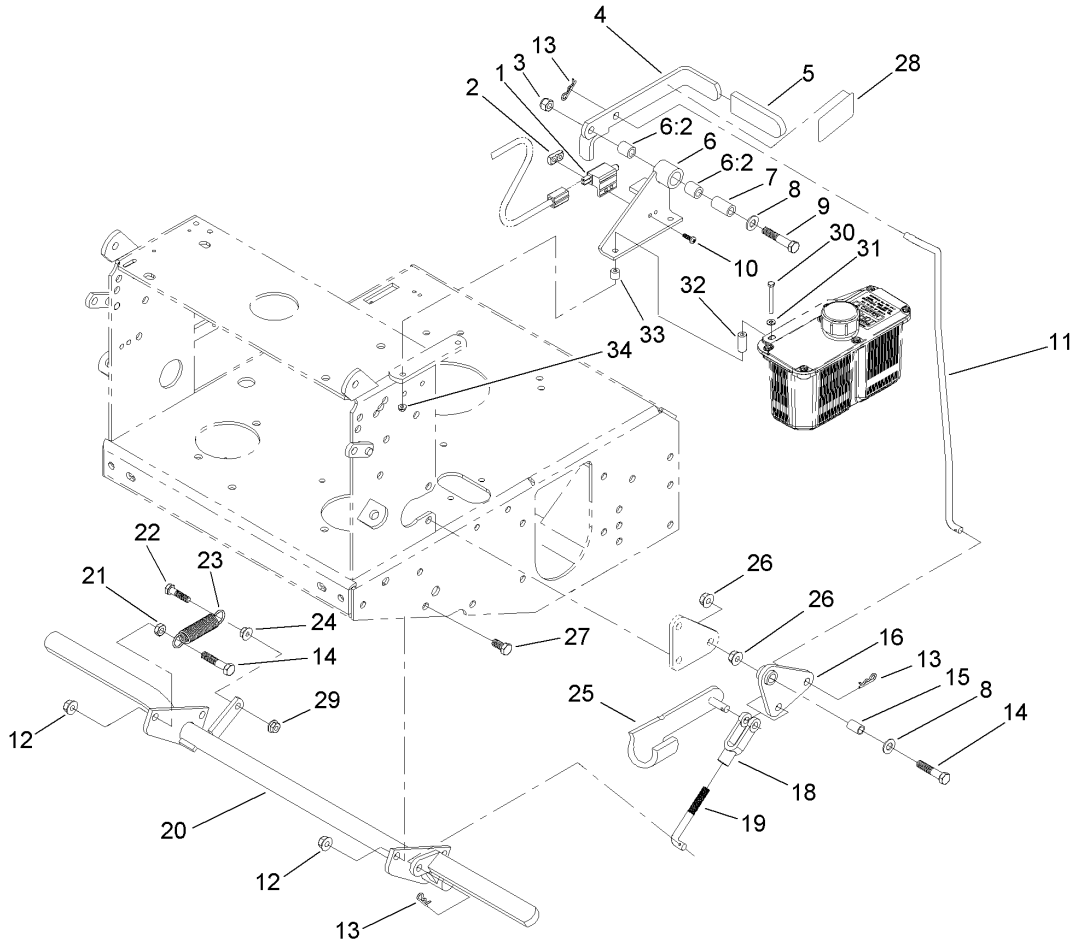

Parking Brake Assembly

Ref	Part No.	Qty.	Description
1	1-513051	1	Switch-Open, Normally
2	1-633181	1	Plate-Tapped
3	3296-39	1	Nut-Lock, NI
4	1-412501-03	1	Lever-Parkbrake
5	1-303020	1	Grip-Lever
6	1-414504	1	Bracket ASM
6:2	1-413347	2	Sleeve-Bushing
7	1-413344	1	Bushing-Pivot
8	3256-24	2	Washer-Flat
9	323-10	1	Screw-HH
10	3290-500	2	Screw-PPH
11	1-413496	1	Linkage-Upper
12	3296-39	4	Nut-Lock, NI
13	1-806003	3	Pin-Hair
14	323-9	2	Screw-HH
15	1-303548	1	Bushing-Plastic
16	1-414508	1	Bellcrank ASM
18	1-633131	1	Yoke-Linkage, Brake
19	1-413489	1	Linkage-Lower
20	103-2085-03	1	Brake ASM
21	3218-3	1	Nut-Jam
22	322-6	1	Screw-HH
23	1-323161	1	Spring-Idler
24	32128-20	1	Nut-HF

Ref	Part No.	Qty.	Description
25	103-2399	1	Pin-Spring, Clevis
26	32128-21	2	Nut-HF
27	323-6	3	Screw-HH
28	103-2103	1	Decal-Brake, Park
29	3296-29	1	Nut-Lock, NI
30	321-23	2	Screw-HH
31	3256-22	2	Washer-Flat
32	103-2191	2	Spacer
33	1-323549	2	Spacer
34	32128-33	2	Nut-HF

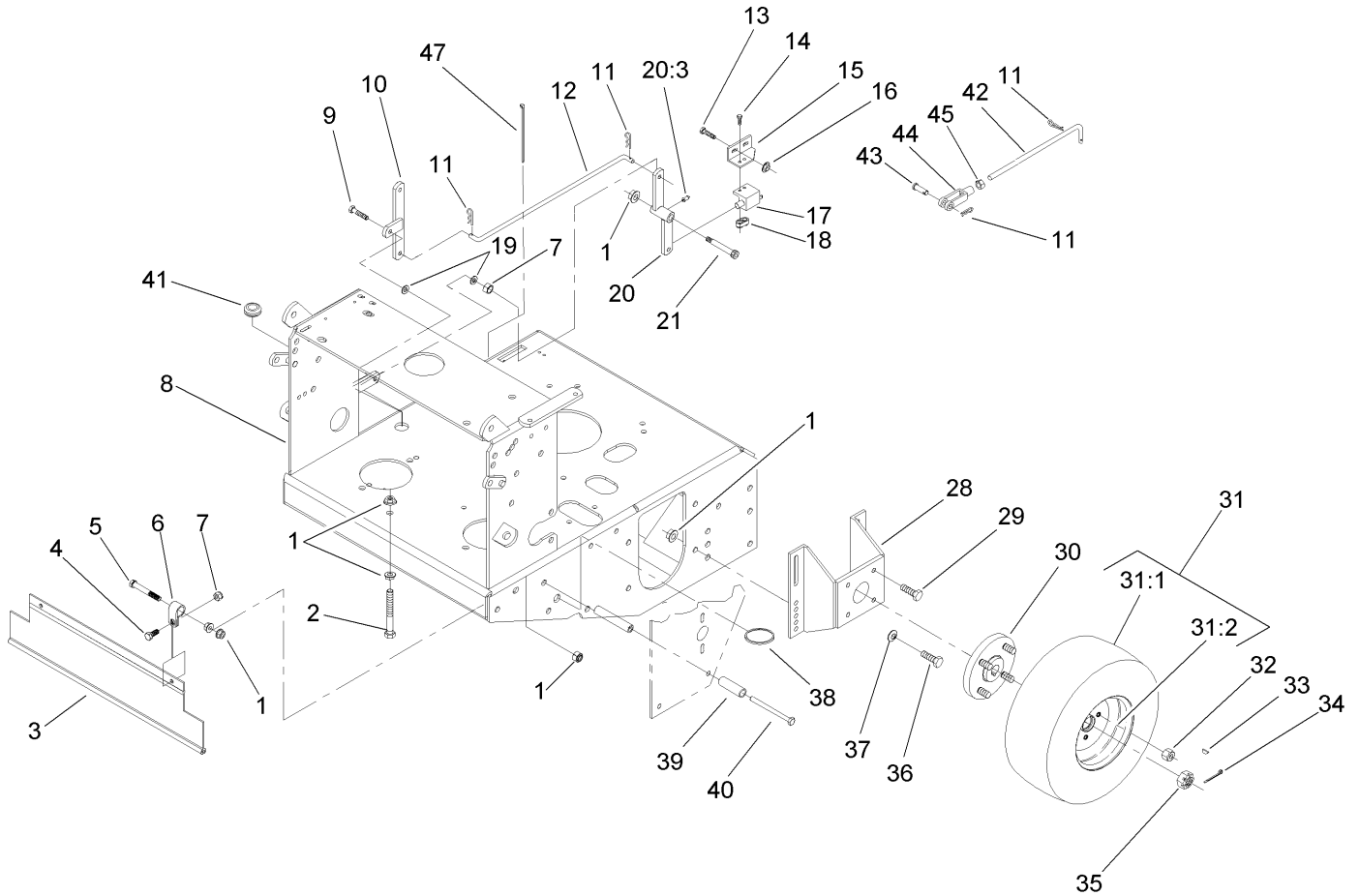

Frame and Wheel Assembly

Ref	Part No.	Qty.	Description
1	3290-357	16	Nut-HHF, Whiz
2	323-11	1	Screw-HH
3	103-2056	1	Shield-Drag
4	322-3	2	Screw-HH
5	323-13	2	Screw-HH
6	1-413510	2	Clip-Loom
7	3296-29	3	Nut-Lock, NI
8	110-6915-01	1	Hydro Frame ASM
9	322-6	1	Screw-HH
10	1-322090-01	1	Bellcrank ASM
11	1-806003	4	Pin-Hair
12	1-323172	1	Linkage-Engage, Blade
13	321-3	2	Screw-HH
14	3290-500	2	Screw-PPH
15	1-323213	1	Bracket-Switch, Blade
16	32128-33	2	Nut-HF
17	1-513051	1	Switch-Open, Normally
18	1-633181	1	Plate-Tapped
19	3256-23	2	Washer-Flat
20	1-322108	1	Bellcrank ASM
20:3	302-40	1	Fitting-Grease
21	1-809062	1	Screw
28	103-2289-01	2	Mount-Motor
29	3234-12	8	Screw-HHF

Ref	Part No.	Qty.	Description
30	1-602997	2	Hub W/Studs
31	31	2	Wheel And Tire ASM
31:1	1-413474	1	Tire-Turfmaster
31:2	1-603715	1	Wheel-Rim
32	242-50	8	Nut-Lug
33	1-807019	2	Key-Woodruff
34	1-806800	2	Pin-Cotter
35	32136-5	2	Nut-Hex, Slotted
36	323-6	8	Screw-HH
37	98-5975	8	Washer-Belleville
38	1-323366	1	Ring-Split
39	105-4820	1	Spacer-Short
40	323-23	1	Screw-HH
41	1-543296	1	Grommet
42	1-323174	1	Arm-Linkage, Assist
43	1-808280	1	Pin-Clevis
44	1-303105	1	Yoke-Adjustable
45	3219-2	1	Nut-Hex
47	1-303287	2	Tie-Plastic

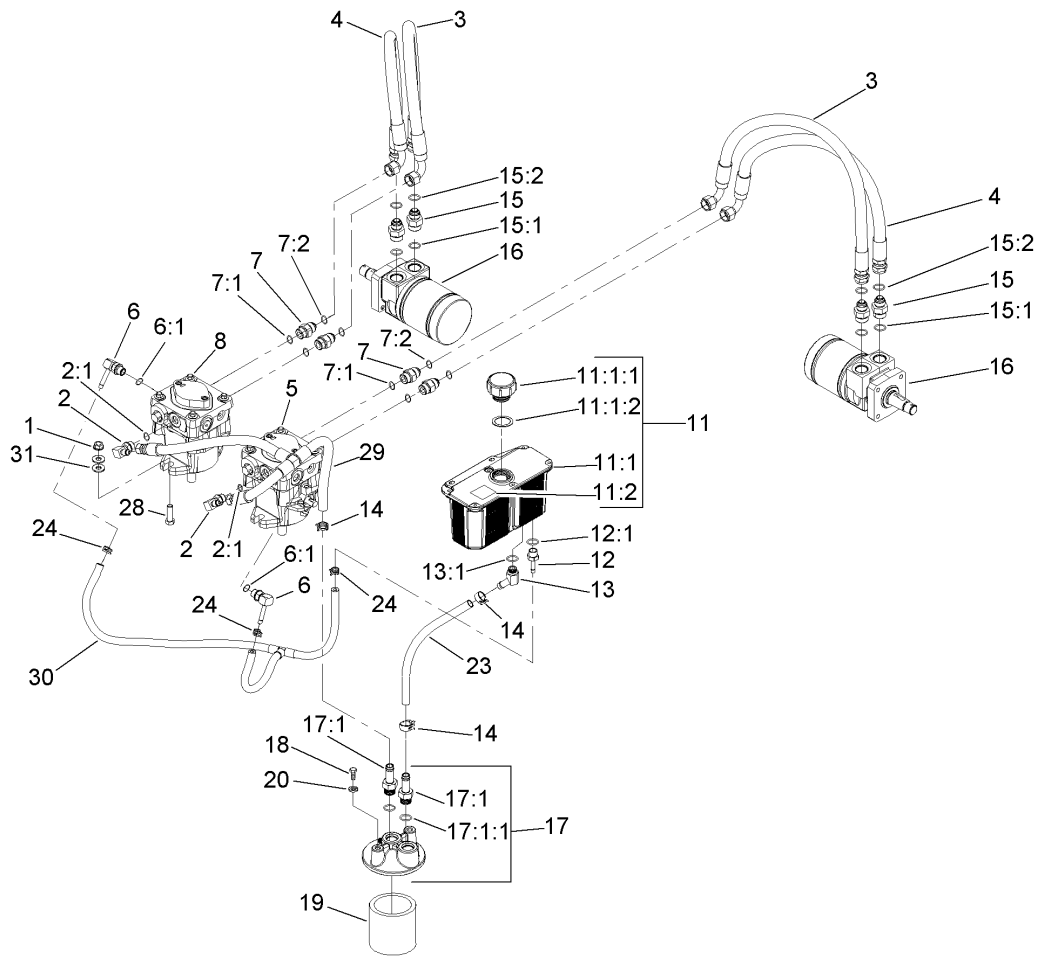

Hydraulic Assembly

Ref	Part No.	Qty.	Description
1	3290-357	4	Nut-HHF, Whiz
2	103-1802	2	Fitting-HYD, 90 DEG
2:1	1-603921	1	O-Ring
3	1-323241	2	Hose-Pressure, High
4	1-613034	2	Hose-Pressure, High
5	103-4611	1	Pump-HYD
●5:1	105-6184	1	Overhaul Seal Kit
●5:2	105-6185	1	Plate-Valve
●5:8	103-2664	1	Input Shaft Kit
●5:9	94-6922	1	Bearing-Thrust
●5:10	103-2666	1	Cylinder Block Kit
6	103-1799	2	Elbow-90 DEG
6:1	237-42	1	O-Ring
7	1-603990	4	Fitting-Straight
7:1	1-603920	1	O-Ring
7:2	1-603992	1	O-Ring
8	106-5490	1	Hydraulic Pump ASM
11	103-1947	1	HYD Reservoir ASM
●11:1		1	Reservoir-HYD
11:1:1	103-1948	1	Cap-Reservoir, HYD
11:1:2	103-1949	1	Gasket-Cap
11:2	1-523552	1	Decal-Tank, HYD
12	103-1801	1	Adapter-Straight
12:1	237-42	1	O-Ring

Ref	Part No.	Qty.	Description
13	103-1807	1	Elbow-45 DEG
13:1	237-42	1	O-Ring
14	103-1988	3	Clamp-Hose
15	1-603991	4	Fitting-Straight
15:1	237-80	1	O-Ring
15:2	1-603992	1	O-Ring
16	1-603718	2	Motor-Wheel
●16:1	1-000119	1	Seal Kit
17	103-2889	1	Filter Head ASM
17:1	103-1912	2	Adapter-Straight
17:1:1	237-42	1	O-Ring
18	321-3	2	Screw-HH
19	1-633750	1	Filter-HYD
20	1-805004	2	Washer-Lock
23	103-2959	1	Hose-Charge
24	103-1716	3	Clamp-Hose
28	323-7	4	Screw-HH
29	103-3914	1	Charge Hose ASM
30	103-4019	1	Case Drain Hose ASM
31	3256-3	8	Washer-Flat

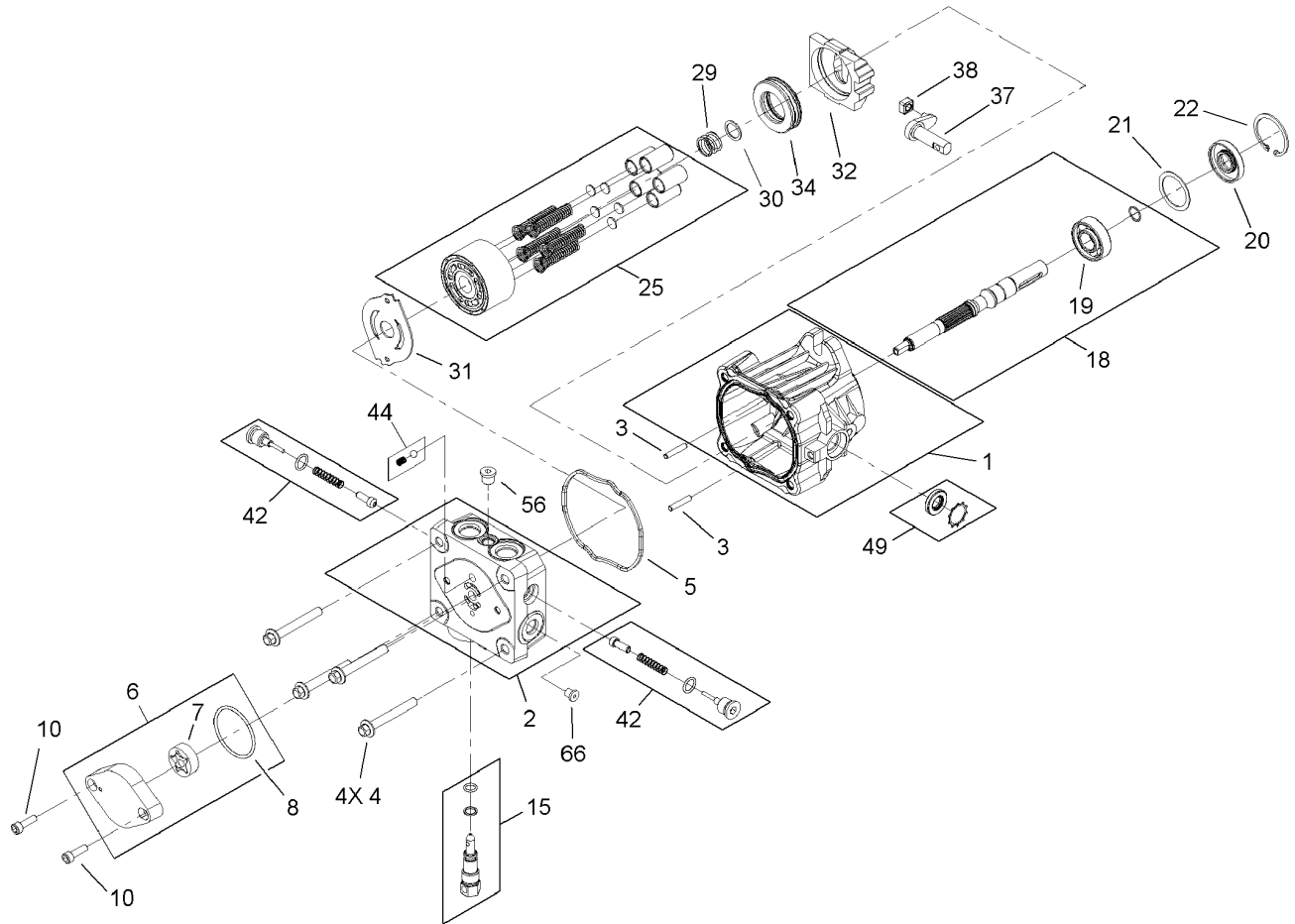

Hydraulic Pump Assembly No. 106-5490

Ref	Part No.	Qty.	Description
1	106-8751	1	Housing Kit
2	106-8752	1	End Cap Kit (W/Poppets)
3	106-8753	2	Pin-Headless, Straight
4	106-8754	4	Bolt-HF
5	106-8755	1	O-Ring
6	106-8756	1	Charge Pump Kit
7	104-2122	1	Gerotor ASM
8	106-8757	1	O-Ring
10	106-8758	2	Screw-HSH
15	106-8759	1	Bypass Valve Kit
18	103-2664	1	Input Shaft Kit
19	104-5311	1	Bearing-Ball
20	104-5310	1	Seal-Lip
21	104-5308	1	Spacer
22	104-5309	1	Ring-Retaining
25	104-2106	1	Cylinder Block ASM
29	94-1936	1	Spring-Block
30	94-1937	1	Washer-Block, Thrust
31	105-6185	1	Plate-Valve
32	94-1907	1	Swashplate-Variable
34	94-6922	1	Bearing-Thrust
37	94-1909	1	Arm-Trunion
38	94-1910	1	Guide-Slot
42	98-3252	2	Valve-Check (W/Poppet)

Ref	Part No.	Qty.	Description
44	106-8760	1	Charge Relief Valve Kit
49	106-8761	1	Trunion Seal / Retainer Kit
56	106-8762	1	Plug-HSH
66	106-8763	1	Plug-HSH
99	105-6184	1	Overhaul Seal Kit

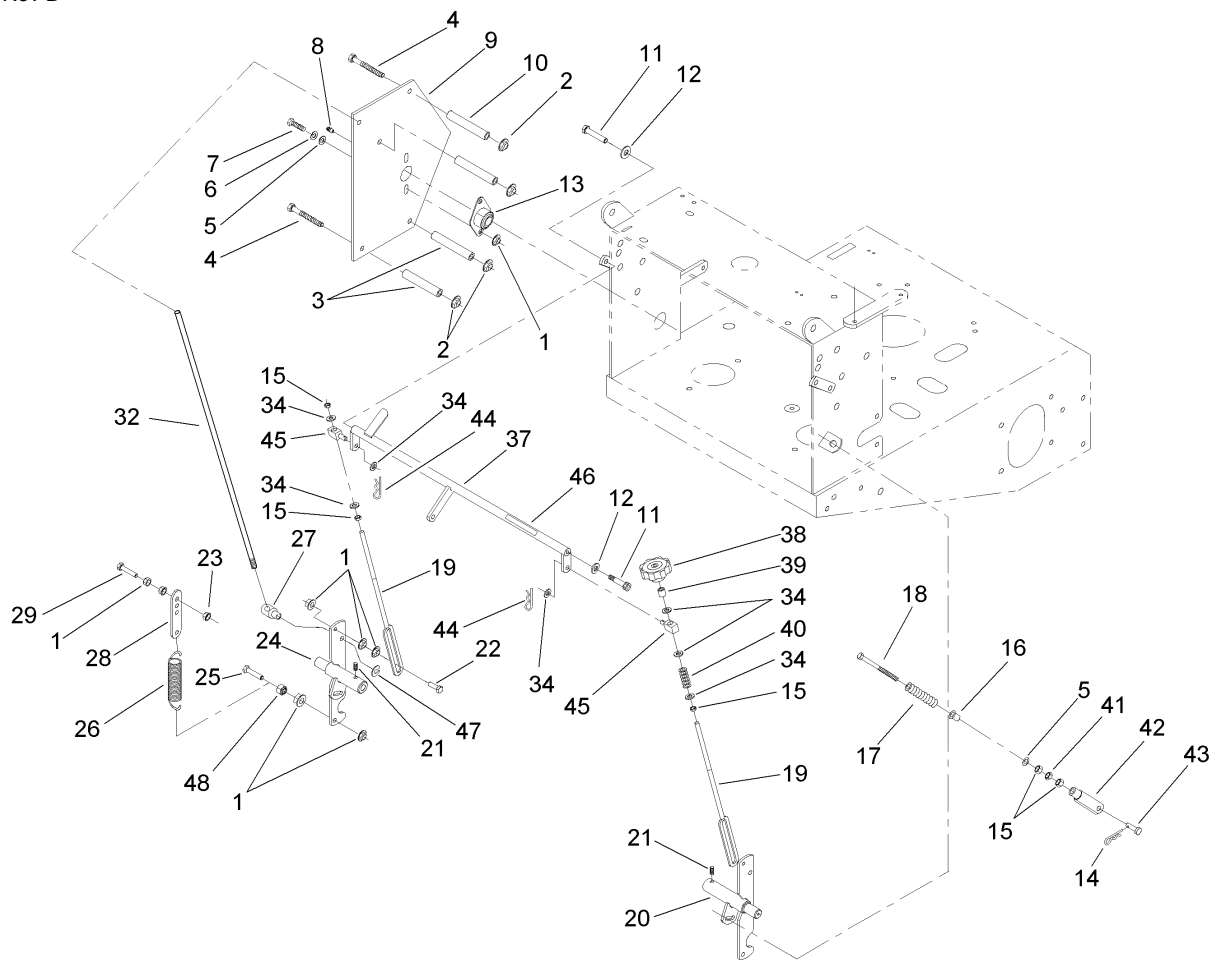

Pivot and Linkage Assembly

Ref	Part No.	Qty.	Description
1	32128-20	18	Nut-HF
2	3290-357	7	Nut-HHF, Whiz
3	1-323197-01	4	Spacer-Shield
4	323-16	7	Screw-HH
5	3256-2	6	Washer-Flat
6	1-805005	4	Washer-Lock
7	322-3	4	Screw-HH
8	302-19	2	Fitting-Grease
9	110-4897-01	2	Shield-Controls, Hydro
10	1-323195-01	4	Spacer-Shield
11	1-809056	2	Screw
12	3256-24	2	Washer-Flat
13	1-633102	2	Bearing-Flange, Side
14	1-806003	2	Pin-Hair
15	3219-2	7	Nut-Hex
16	1-603735	2	Bushing-Flanged
17	1-603807	2	Spring-Return, Neutral
18	1-603737	2	Bolt-Return, Neutral
19	1-413350	2	Link-Control, Speed
20	103-4796-01	1	Shaft-Control, RH
21	1-803022	2	Screw-Set
22	1-403180	2	Screw-HH
23	3296-29	2	Nut-Lock, NI
24	103-1190-01	1	Shaft-Control, LH

Ref	Part No.	Qty.	Description
25	322-6	2	Screw-HH
26	1-603693	2	Spring-Extension
27	103-1235	2	Swivel-Lever, Drive
28	1-613089	2	Tab-Spring, Extension
29	1-800016	2	Bolt-TAP, HH
32	1-413219	2	Rod-Lever, Drive
34	3256-23	7	Washer-Flat
37	1-412203-01	1	Crank-Control, Speed
38	1-413151	1	Knob-Tracking
39	1-603903	1	Spacer
40	1-323245	1	Spring-Compression
41	3220-2	2	Nut-Jam
42	1-303105	2	Yoke-Adjustable
43	1-808280	2	Pin-Clevis
44	3272-5	2	Pin-Cotter
45	1-603676	2	Swivel-Adjustable, Short
46	105-4109	1	Decal-Tracking
47	32151-47	2	Ring-Retaining
48	3218-2	2	Nut-Jam

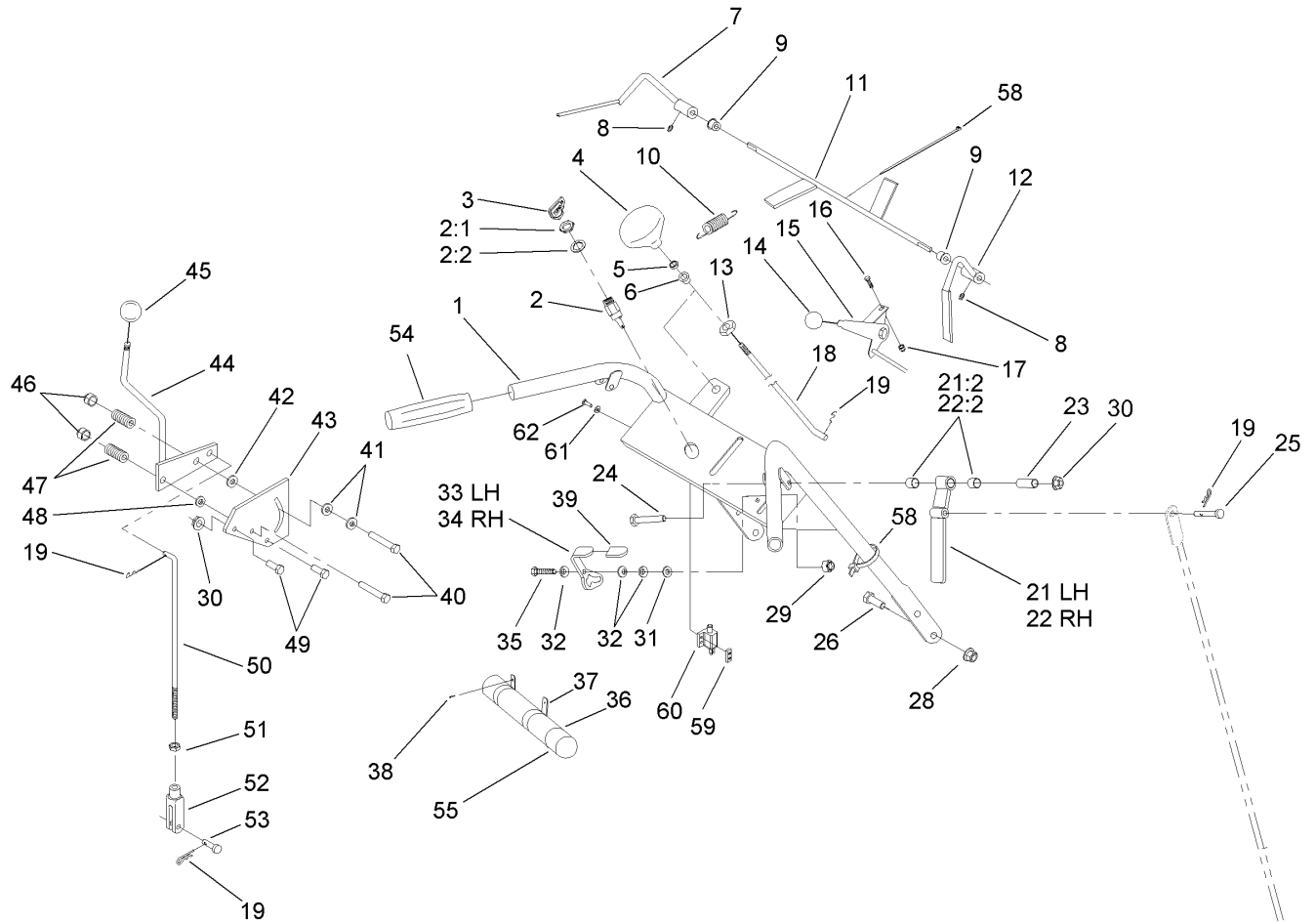

Handle and Control Assembly

Ref	Part No.	Qty.	Description
1	110-6907	1	Hydro Handle ASM
2	29-5560	1	Switch-On / Off
2:1	218-461	1	Nut-HH
2:2	3254-5	1	Washer-Tooth
3	63-8360	1	Key-Ignition
4	1-323134	1	Knob-Push/Pull
5	3218-2	1	Nut-Jam
6	1-323143	1	Bearing-Nylon
7	106-5485	1	LH Opc Lever ASM
8	1-803322	2	Screw-Set
9	1-303365	2	Bushing-Nylon
10	1-303363	1	Spring-Extension
11	106-2717-03	1	Rod-Control, Operator Presence
12	106-5486	1	RH Opc Lever ASM
13	1-323142	1	Nut-Push
14	1-513592	1	Knob-Ball
15	1-633696	1	Throttle Cable ASM
16	1-807513	2	Bolt-CARR
17	3296-2	2	Nut-Lock
18	1-323181	1	Linkage-Blade
19	1-806003	5	Pin-Hair
21	103-0218	1	LH Drive Lever ASM
21:2	1-413152	2	Sleeve-Bushing
22	103-0219	1	RH Drive Lever ASM

Ref	Part No.	Qty.	Description
22:2	1-413152	2	Sleeve-Bushing
23	1-603749	2	Bushing-Lever, Drive
24	321-9	2	Screw-HH
25	1-613055	2	Pin-Clevis
26	3234-11	4	Screw-HHF
28	32128-21	4	Nut-HF
29	3296-42	2	Nut-Lock, NI
30	32128-33	4	Nut-HF
31	3256-2	2	Washer-Flat
32	1-303435	6	Washer-Spring
33	1-612167	1	LH Grip/Latch ASM
34	1-612168	1	RH Grip/Latch ASM
35	321-10	2	Screw-HH
36	104-7050	1	Housing-Manual
37	2412-120	2	R-Clamp
38	32104-76	2	Screw
39	1-303019	2	Grip-Latch
40	322-10	2	Screw-HH
41	1-603716	1	Washer-Friction
42	1-323244	2	Washer-Friction
43	1-603730	1	Plate-Lever, Shifter
44	106-2748	1	Lever-Shift
45	1-603175	1	Knob-Ball
46	3296-29	2	Nut-Lock, NI

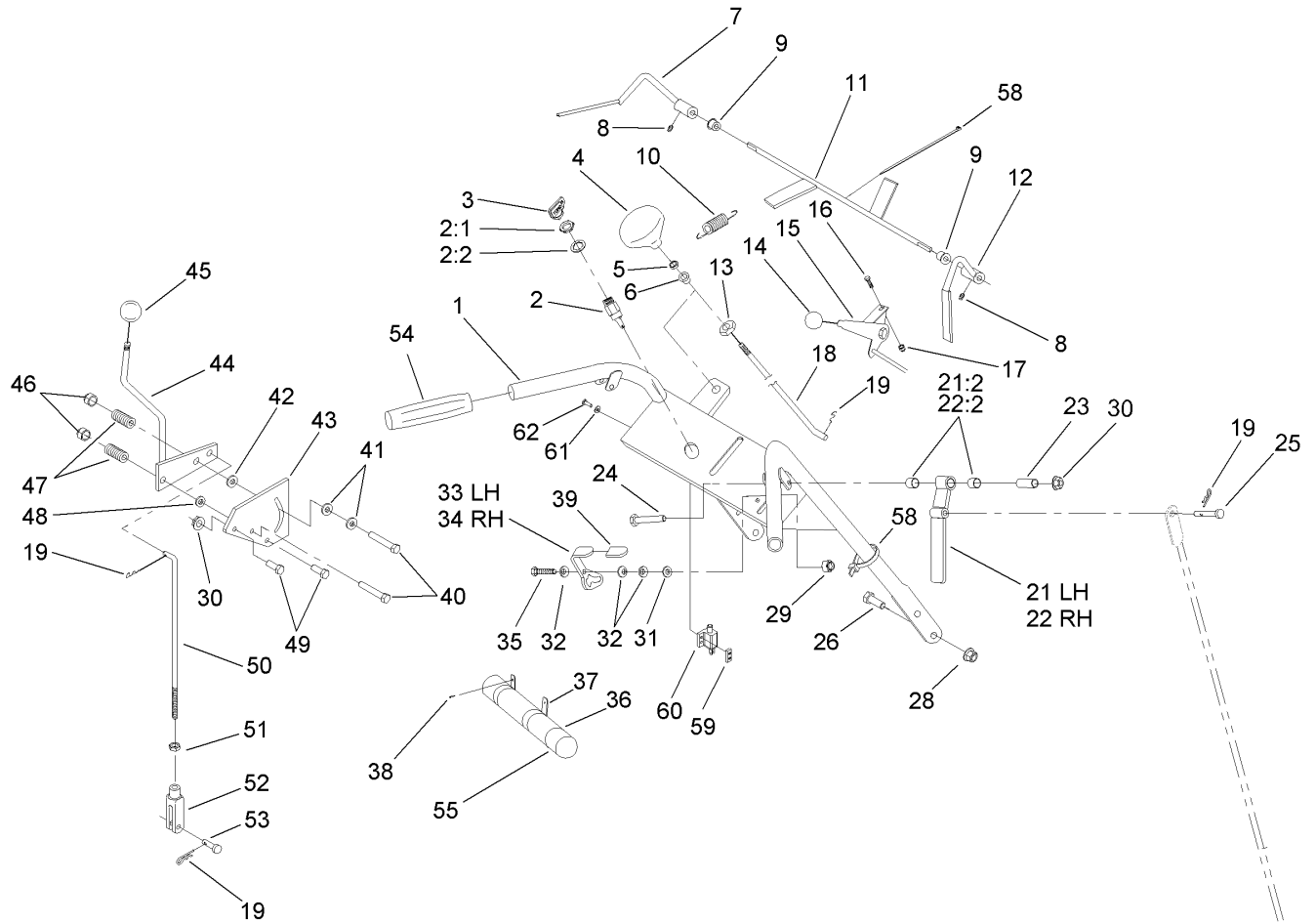

Handle and Control Assembly (continued)

Ref	Part No.	Qty.	Description
47	1-323245	2	Spring-Compression
48	3256-23	1	Washer-Flat
49	321-3	2	Screw-HH
50	1-323522	1	Rod-Control, Speed
51	3220-2	1	Nut-Jam
52	1-303105	1	Yoke-Adjustable
53	1-808280	1	Pin-Clevis
54	104-9838	2	Grip-Foam
55	104-7048	1	Cap-Housing
58	1-303287	3	Tie-Plastic
59	1-633181	1	Plate-Tapped
60	1-513051	1	Switch-Open, Normally
61	3256-14	2	Washer-Flat
62	3290-500	2	Screw-PPH
●63	103-2007	1	Harness-Wiring

--	--	--	--

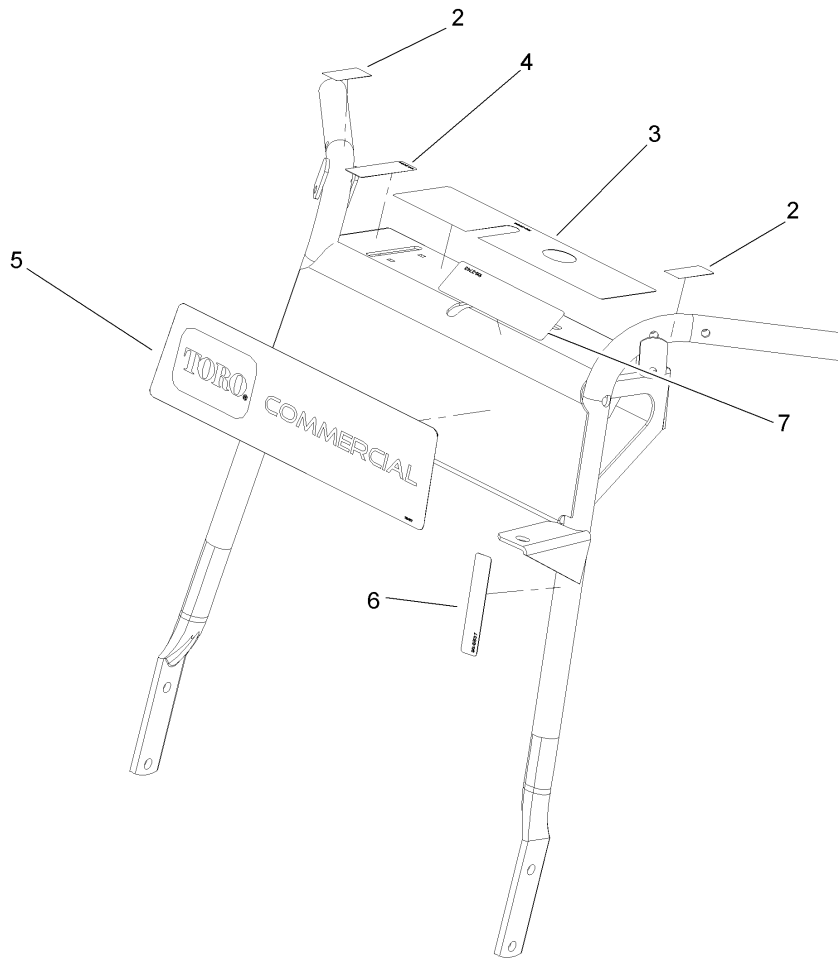

Control panel Assembly No. 110-6907

Ref	Part No.	Qty.	Description
2	105-4110	2	Decal-Lock, Neutral
3	106-2738	1	Decal-Warning
4	106-2733	1	Decal-Throttle
5	110-6917	1	Decal-Control Panel
6	95-5537	1	Decal-Engage, Deck
7	106-2743	1	Decal-Caution, Brake

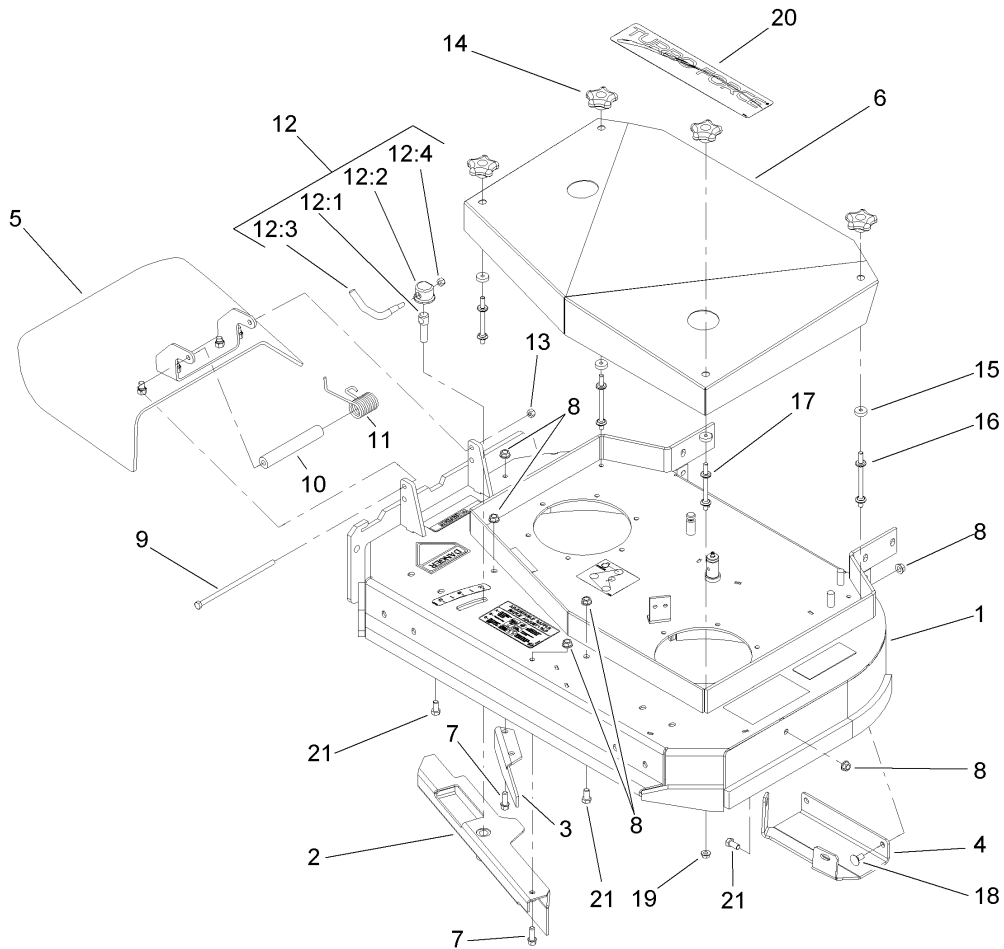

Deck Assembly

Ref	Part No.	Qty.	Description
1	110-4907	1	Deck ASM
2	110-2031-01	1	Adjustable Baffle
3	110-0754-01	1	Baffle-Discharge
4	110-2037-01	1	Plate-Skid
5	110-0790	1	Deflector ASM
6	110-2036-01	1	Cover-Deck
7	92-1624	3	Screw
8	3290-357	10	Nut-HHF, Whiz
9	322-50	1	Screw-HH
10	105-4622	1	Spacer
11	104-8554	1	Spring-Torsion
12	107-1664	1	Lever ASM
12:1	106-3239	1	Screw-Lock
12:2	107-1644	1	Cap-Lock
12:3	106-3241	1	Lever-Lock
12:4	3296-29	1	Nut-Lock, NI
13	3296-29	1	Nut-Lock, NI
14	106-4161	4	Knob-Handle
15	1-323417	4	Washer
16	1-303536	2	Stud-Shield, Belt (Long)
17	1-303537	2	Stud-Shield, Belt (Short)
18	3231-1	4	Screw-CARR
19	32128-20	4	Nut-HF
20	110-6918	1	Decal

Ref	Part No.	Qty.	Description
21	323-4	3	Screw-HH

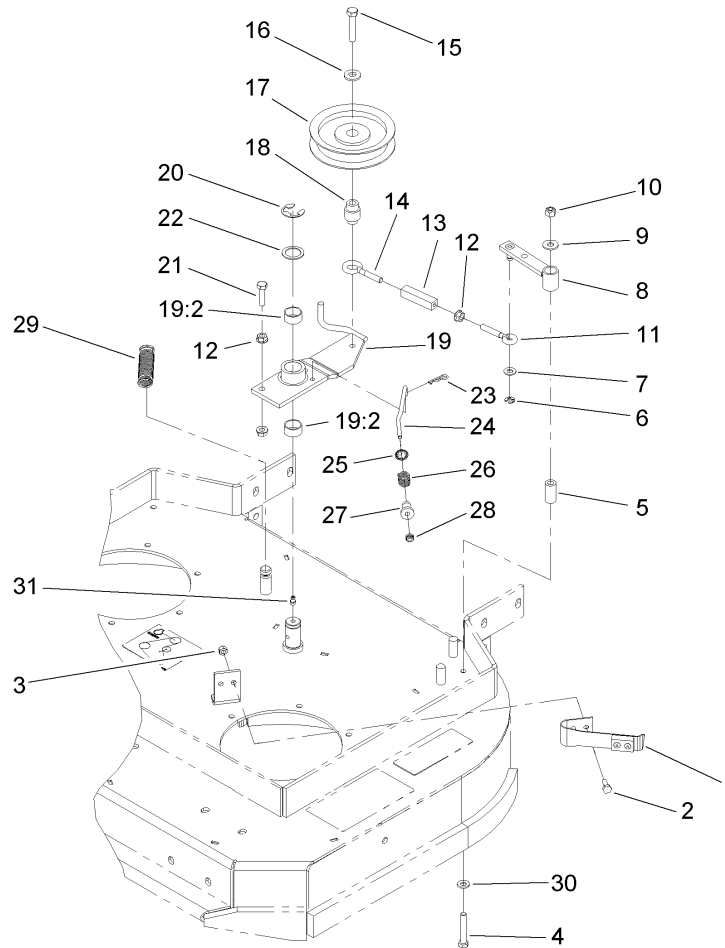

Idler Assembly

Ref	Part No.	Qty.	Description
1	1-324372	1	Pad / Spring ASM
2	321-4	2	Screw-HH
3	3296-42	2	Nut-Lock, NI
4	322-10	1	Screw-HH
5	1-403179	1	Tube-Pivot
6	32120-35	1	E-Ring
7	3256-23	1	Washer-Flat
8	1-322235	1	Arm-Assist
9	3256-3	1	Washer-Flat
10	3296-29	1	Nut-Lock, NI
11	1-303238	1	Eyebolt-Thread, RH
12	32128-20	3	Nut-HF
13	1-303236	1	Body-Turnbuckle
14	1-303348	1	Eyebolt-Thread, LH
15	702809	1	Screw-Cap
16	98-5975	1	Washer-Belleville
17	1-603843	1	Pulley-Idler
18	1-303434	1	Bushing-Engagement
19	103-3600	1	Idler Arm ASM
19:2	1-323729	2	Sleeve-Bearing
20	32151-103	1	Ring-Snap
21	322-6	1	Screw-HH
22	1-303352	1	Washer-Spindle
23	1-806003	1	Pin-Hair

Ref	Part No.	Qty.	Description
24	1-323715	1	Rod-Brake
25	1-323748	1	Ring-Push On
26	1-323747	1	Spring-Compression
27	1-323746	1	Spacer-Flanged
28	3296-56	1	Nut-Lock, NI
29	1-323071	1	Spring-Extension
30	1-303334	1	Washer-Spring
31	302-19	2	Fitting-Grease

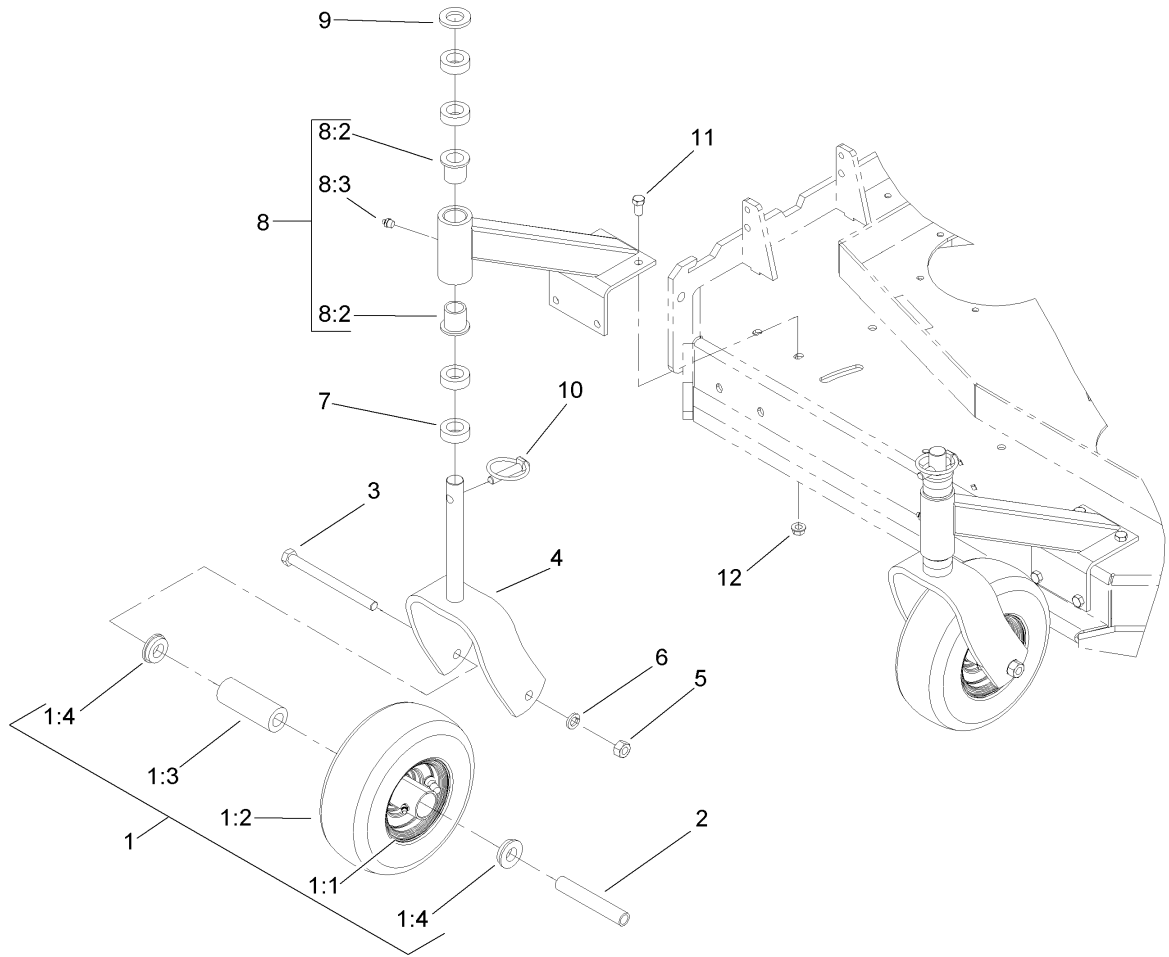

Castor Assembly

Ref	Part No.	Qty.	Description
1	1-513648	2	Wheel And Tire ASM
② 1:1		1	Rim
1:2	1-513808	1	Tire
1:3	1-513809	1	Bearing
1:4	1-513810	2	Bushing
2	1-513547	2	Spacer
3	325-20	2	Screw-HH
4	1-322145-01	2	Fork
5	3217-9	2	Nut-Hex
6	3253-7	2	Washer-Lock
7	1-303314	8	Spacer-Caster
8	110-2130	2	Support ASM
8:2	1-303514	2	Bearing-Flanged
8:3	302-52	1	Fitting-Grease
9	1-513338	2	Washer-Flat
10	1-809020	2	Pin
11	323-4	8	Screw-HH
12	3290-357	8	Nut-HHF, Whiz

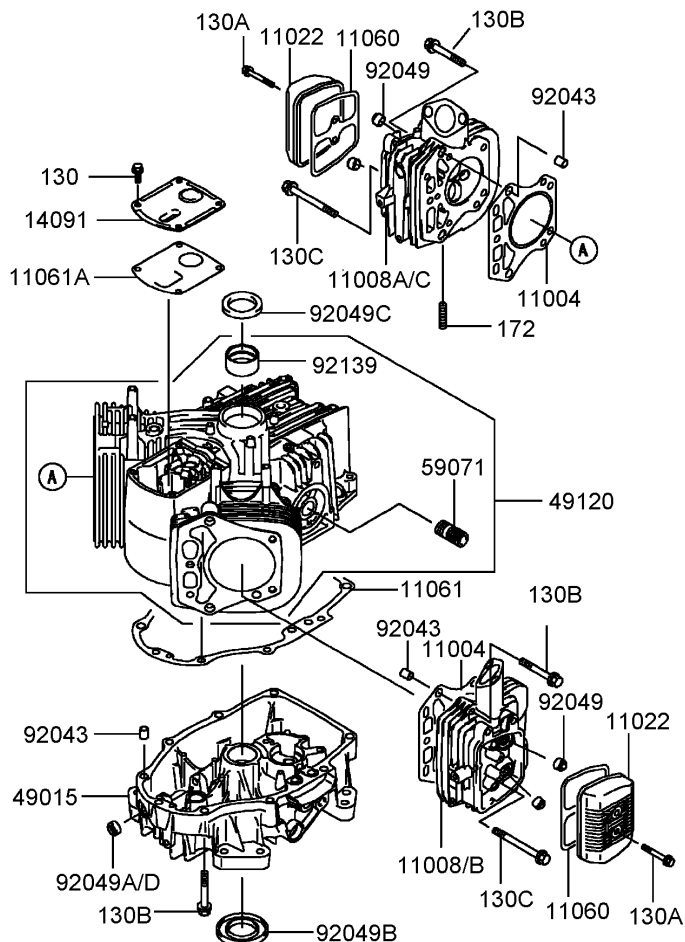

Cylinder and Crankcase Assembly Kawasaki Model FH430V-AS25

Ref	Part No.	Qty.	Description
●11004	11004-7008	1	Gasket-Head
●11008	11008-7011	1	Head-Comp-Cylinder, No.2
●11008A	11008-7017	1	Head-Comp-Cylinder, No.1
●11008B	11008-7021	1	Head-Cylinder, No. 2
●11008C	11008-7022	1	Head-Cylinder, No. 1
●11022	11022-7003	1	Case-Rocker
●11060	11060-7001	1	Gasket-Case, Rocker
●11061	11061-7007	1	Gasket-Cover, Crankcase
●11061A	11061-7008	1	Gasket-Breather
●14091	14091-7007	1	Cover
●49015	49015-7032	1	Cover-Crankcase
●49120	49120-7015	1	Crankcase
●59071	59071-2079	1	Joint
●92043	92043-7001	1	Pin
●92049	92049-7001	1	Seal-Oil, Rvc2 (6X11X10.2)
●92049A	92049-7005	1	Seal-Oil, So (8X14X5 Hs)
●92049B	92049-7015	1	Seal-Oil, Sd (35X62X8 L Hs)
●92049C	92049-7016	1	Seal-Oil, Sd (35X48X8 R Hs)
●92049D	92049-7019	1	Seal-Oil, So (8X14X5 Hs)
●92139	92139-7002	1	Bushing
●130	130B0612	1	Bolt-Flanged
●130A	130B0640	1	Bolt-Flanged
●130B	130T0850	1	Bolt-Flanged
●130C	130T0875	1	Bolt-Flanged

Ref	Part No.	Qty.	Description
●172	172G0818	1	Bolt-Stud

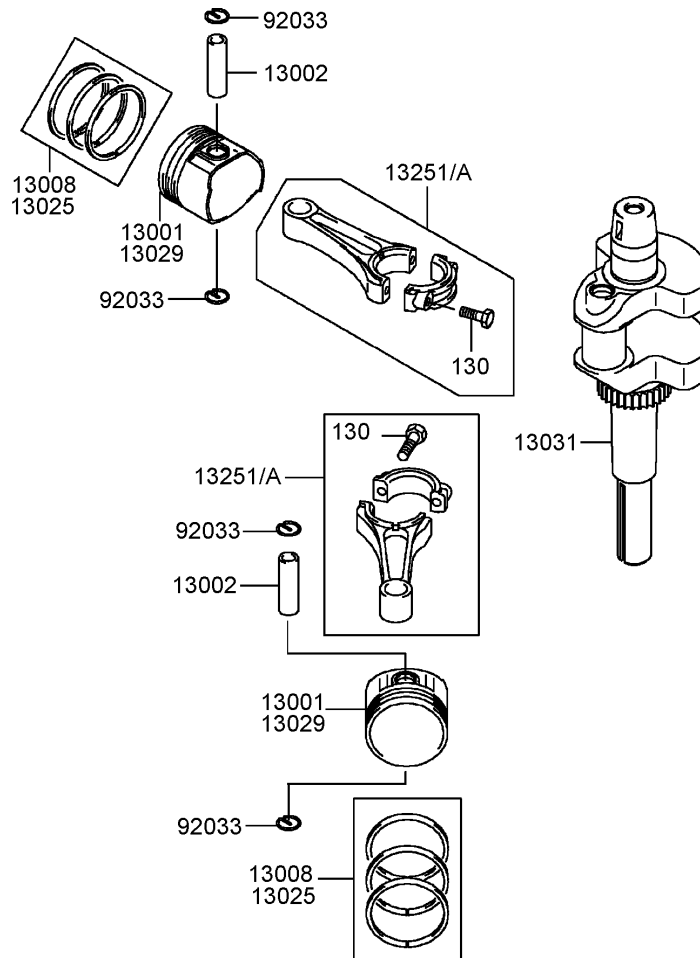

Piston and Crankshaft Assembly Kawasaki Model FH430V-AS25

Ref	Part No.	Qty.	Description
● 13001	13001-7009	1	Piston-Engine
● 13002	13002-7001	1	Pin-Piston
● 13008	13008-7001	1	Ring Set-Piston
● 13025	13025-7003	1	Ring Set-Piston (L,0.50)
● 13029	13029-7005	1	Piston-Engine (L,0.50)
● 13031	13031-7033	1	Crankshaft
● 13251	13251-7007	1	Connecting Rod ASM
● 13251A	13251-7008	1	Connecting Rod ASM (U/S=0.50)
● 92033	92033-7005	1	Ring-Snap
● 130	130G0630	1	Bolt-Flanged

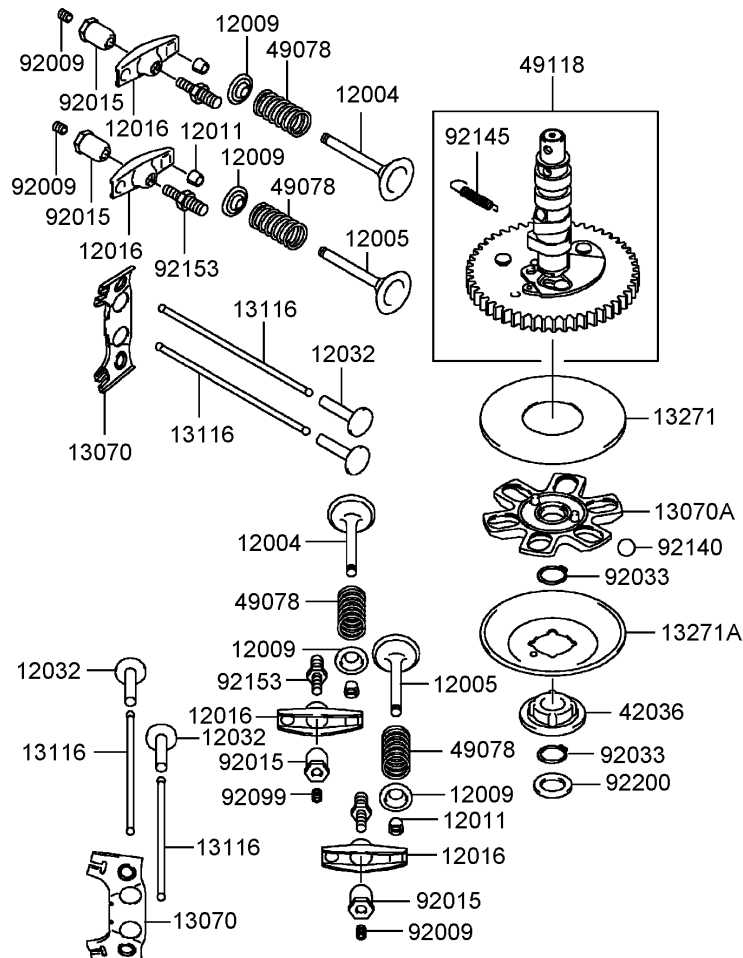

Valve and Camshaft Assembly Kawasaki Model FH430V-AS25

Ref	Part No.	Qty.	Description
①12004	12004-7003	1	Valve-Intake
①12005	12005-7003	1	Valve-Exhaust
①12009	12009-7001	1	Retainer-Spring, Valve
①12011	12011-2056	1	Collet
①12016	12016-7001	1	Arm-Rocker
①12032	12032-7001	1	Tappet
①13070	13070-7001	1	Guide
①13070A	13070-7004	1	Guide
①13116	13116-2057	1	Rod-Push
①13271	13271-7007	1	Plate
①13271A	13271-7021	1	Plate-Governor
①42036	42036-7009	1	Sleeve
①49078	49078-7001	1	Spring-Valve, Engine
①49118	49118-7009	1	Camshaft
①92009	92009-2341	1	Screw
①92015	92015-2253	1	Nut
①92033	92033-7001	1	Ring-Snap
①92140	92140-7002	1	Ball
①92145	92145-7001	1	Spring
①92153	92153-7019	1	Bolt
①92200	92200-7001	1	Washer

--	--	--	--

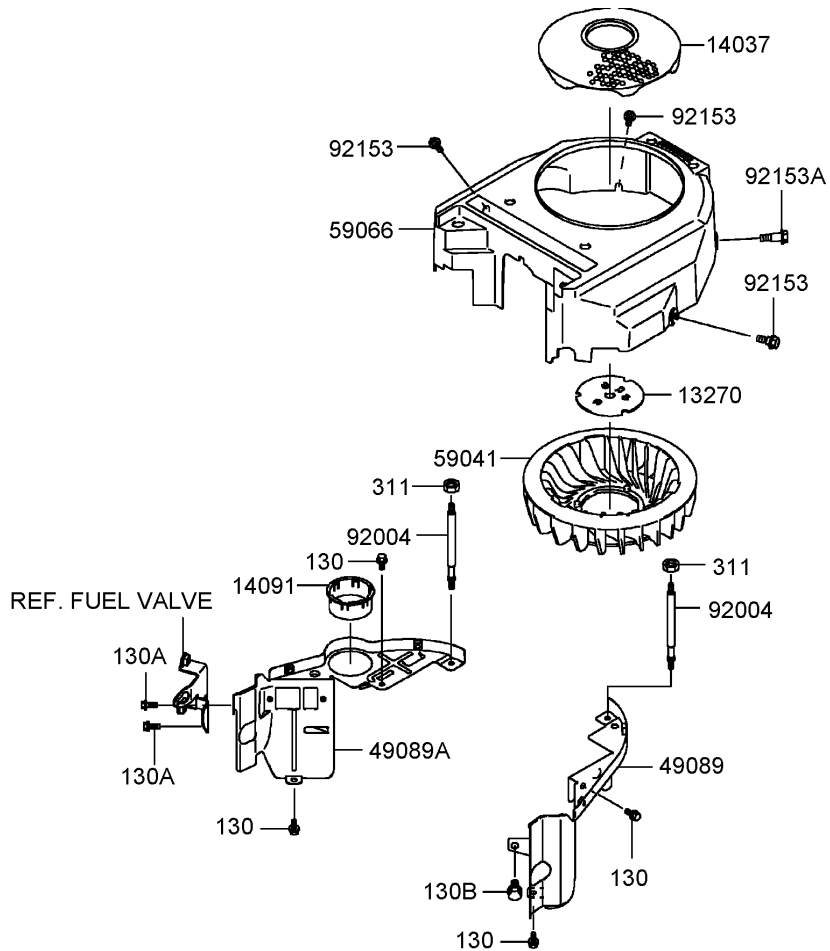

Cooling Equipment Assembly Kawasaki Model FH430V-AS25

Ref	Part No.	Qty.	Description
③13270	13270-7007	1	Plate
③14037	14037-7021-9H	1	Screen
③14091	14091-7009	1	Cover
③49089	49089-7044	1	Shroud-Engine
③49089A	49089-7045	1	Shroud-Engine
③59041	59041-7010	1	Fan
③59066	59066-7023	1	Housing-Fan
③92004	92004-7007	1	Stud
③92153	92153-7007	1	Bolt
③92153A	92153-7008	1	Bolt
③130	130B0612	1	Bolt-Flanged
③130A	130B0616	1	Bolt-Flanged
③130B	130B0816	1	Bolt-Flanged
③311	311F0600	1	Nut-Hex

--	--	--	--

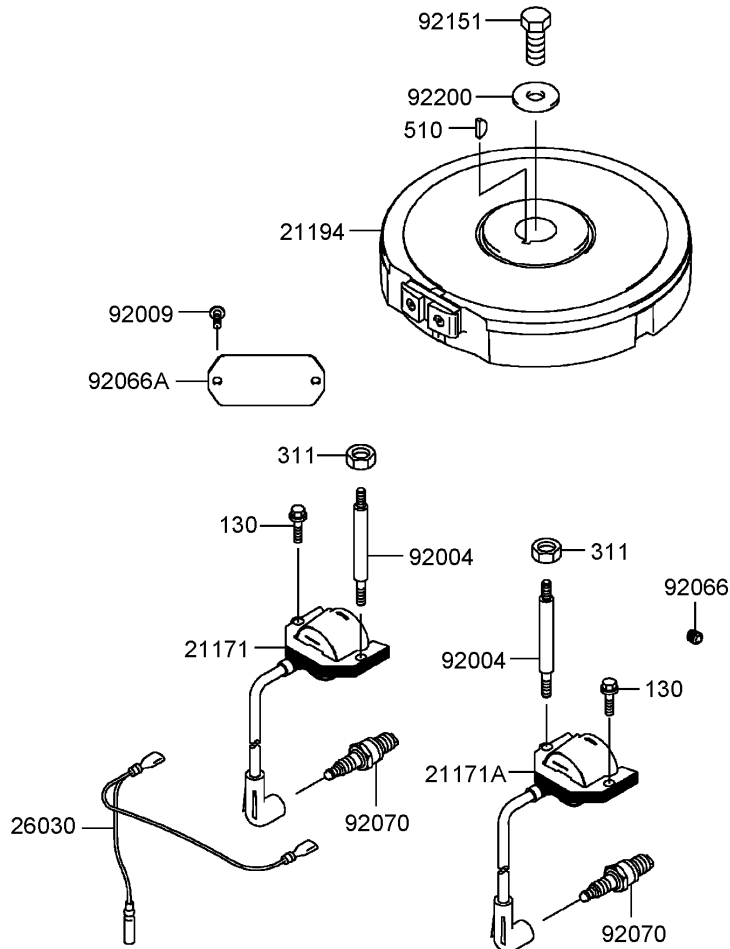

Electric Equipment Assembly Kawasaki Model FH430V-AS25

Ref	Part No.	Qty.	Description
③21171	21171-7013	1	Ignition Coil ASM
③21171A	21171-7014	1	Ignition Coil ASM
③21194	21194-7013	1	Flywheel-Comp
③26030	26030-7001	1	Harness
③92004	92004-7008	1	Stud
③92009	92009-2308	1	Screw
③92066	92066-7002	1	Plug
③92066A	92066-7005	1	Plug
③92070	92070-7003	1	Plug-Spark (Rcj8Y, Solid)
③92151	92151-2097	1	Bolt (12X30)
③92200	92200-7002	1	Washer
③130	130B0620	1	Bolt-Flanged
③311	311F0600	1	Nut-Hex
③510	510A5100	1	Key-Woodruff

--	--	--	--

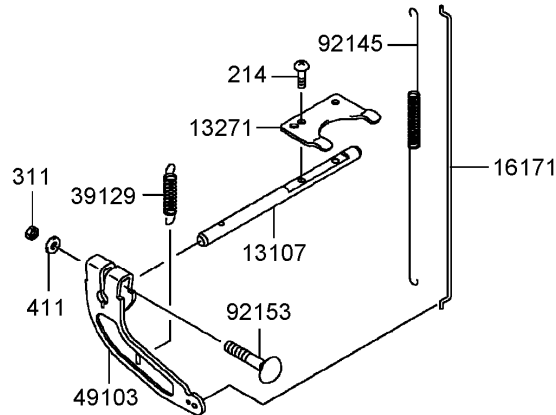
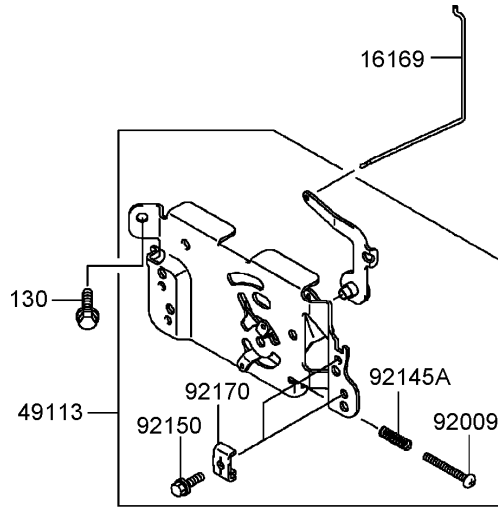

Control Equipment Assembly Kawasaki Model FH430V-AS25

Ref	Part No.	Qty.	Description
③13107	13107-7010	1	Shaft
③13271	13271-7018	1	Plate
③16169	16169-7012	1	Link-Choke
③16171	16171-7007	1	Link
③39129	39129-7003	1	Spring-Governor
③49103	49103-7004	1	Arm-Governor
③49113	49113-7024	1	Panel-Control
③92009	92009-7007	1	Screw (4X35)
③92145	92145-7003	1	Spring
③92145A	92145-7005	1	Spring
③92150	92150-2182	1	Bolt (5X18)
③92153	92153-7005	1	Bolt (6X35)
③92170	92170-7001	1	Clamp
③130	130B0612	1	Bolt-Flanged
③214	214B0408	1	Screw-Pan
③311	311B0600	1	Nut-Hex
③411	411b0600	1	Washer-Plain

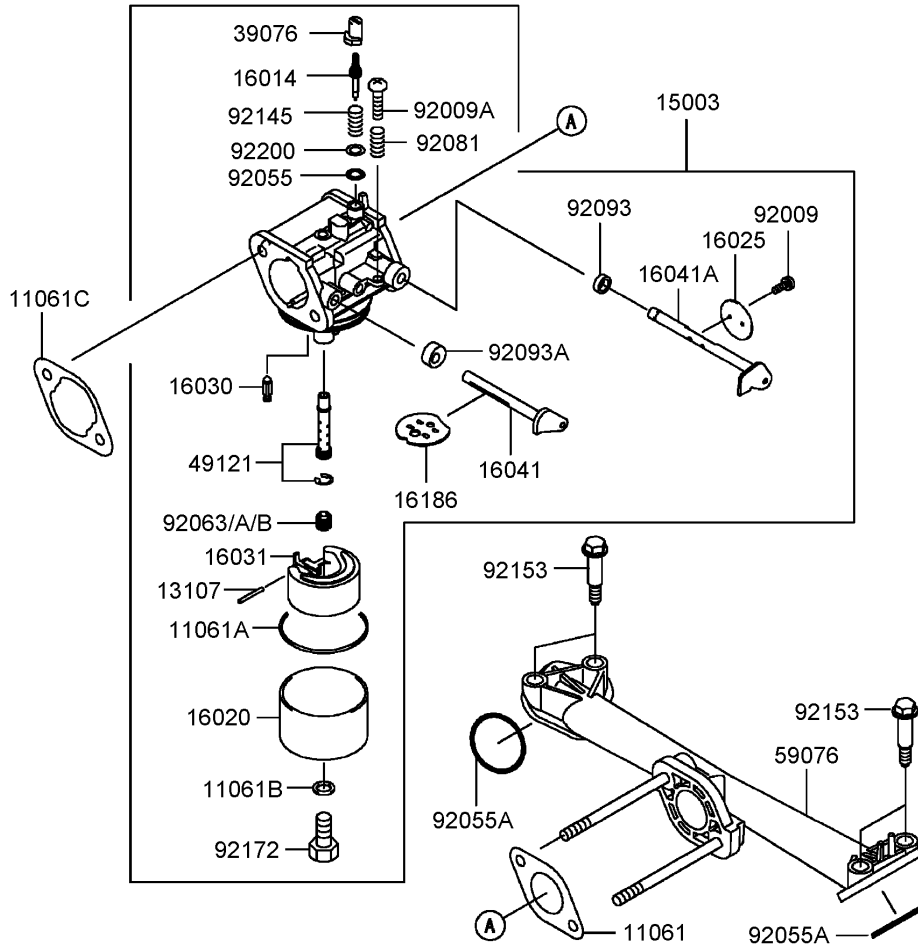

Carburetor Assembly Kawasaki Model FH430V-AS25

Ref	Part No.	Qty.	Description
● 11061	11061-7004	1	Gasket-Insulator
● 11061A	11061-7009	1	Gasket-Chamber
● 11061B	11061-7010	1	Gasket-Screw
● 11061C	11061-7018	1	Gasket-Cleaner, Air
● 13107	13107-7018	1	Shaft
● 15003	15003-7061	1	Carburetor ASM
● 16014	16014-7002	1	Screw-Pilot
● 16020	16020-7003	1	Chamber-Float
● 16025	16025-7006	1	Valve-Throttle
● 16030	16030-7003	1	Valve-Float
● 16031	16031-7002	1	Float
● 16041	16041-7016	1	Shaft-Choke, Carburetor
● 16041A	16041-7018	1	Shaft-Throttle, Carburetor
● 16186	16186-7002	1	Choke Valve ASM
● 39076	39076-7001	1	Limiter
● 49121	49121-7001	1	Nozzle-Main
● 59076	59076-7005	1	Manifold-Intake
● 92009	92009-2083	1	Screw
● 92009A	92009-2349	1	Screw
● 92055	92055-2174	1	O-Ring
● 92055A	92055-7007	1	O-Ring (Id=31)
● 92063	92063-7026	1	Jet-Main, No. 88
● 92063A	92063-7028	1	Jet-Main, No. 85
● 92063B	92063-7029	1	Jet-Main, No. 82

Ref	Part No.	Qty.	Description
● 92081	92081-2234	1	Spring
● 92093	92093-2100	1	Seal
● 92093A	92093-7003	1	Seal
● 92145	92145-7015	1	Spring
● 92153	92153-7009	1	Bolt
● 92172	92172-7002	1	Screw
● 92200	92200-7014	1	Washer

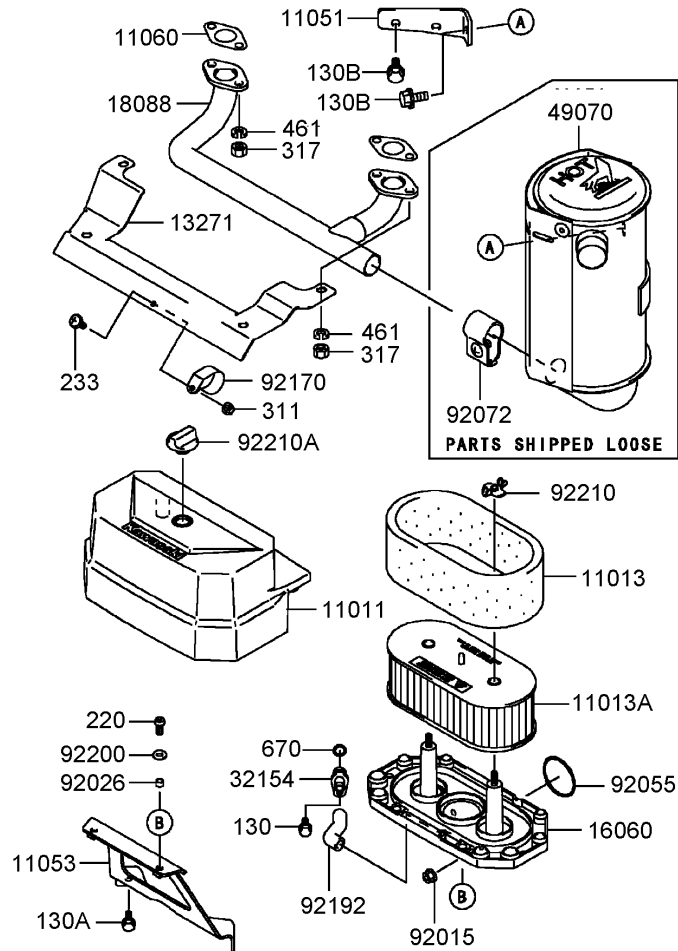

Air Filter and Muffler Assembly Kawasaki Model FH430V-AS25

Ref	Part No.	Qty.	Description
③11011	11011-7035	1	Case-Filter, Air
③11013	11013-7025	1	Element-Filter, Air
③11013A	11013-7031	1	Element-Filter, Air
③11051	11051-7005-9H	1	Bracket
③11053	11053-7022	1	Bracket
③11060	11060-7021	1	Gasket-Muffler
③13271	13271-7022	1	Plate
③16060	16060-7016	1	Pipe-Intake
③18088	18088-7001	1	Pipe-Exhaust
③32154	32154-7006	1	Pipe
③49070	49070-7015	1	Muffler
③92015	92015-1193	1	Nut
③92026	92026-7001	1	Spacer (6.2X7.9X5)
③92055	92055-7015	1	Ring-O
③92072	92072-7008	1	Band
③92170	92170-7002	1	Clamp
③92192	92192-7010	1	Tube
③92200	92200-2070	1	Washer
③92210	92210-7004	1	Nut
③92210A	92210-7019	1	Nut
③130	130B0610	1	Bolt-Flanged
③130A	130B0612	1	Bolt-Flanged
③130B	130B0816	1	Bolt-Flanged

Ref	Part No.	Qty.	Description
③220	220B0614	1	Screw-Pan (Cross)
③233	233B0416	1	Screw
③311	311B0400	1	Nut-Hex
③317	317R0800	1	Nut-Hex
③461	461F0800	1	Washer-Spring
③670	670B2010	1	O-Ring (10Mm)

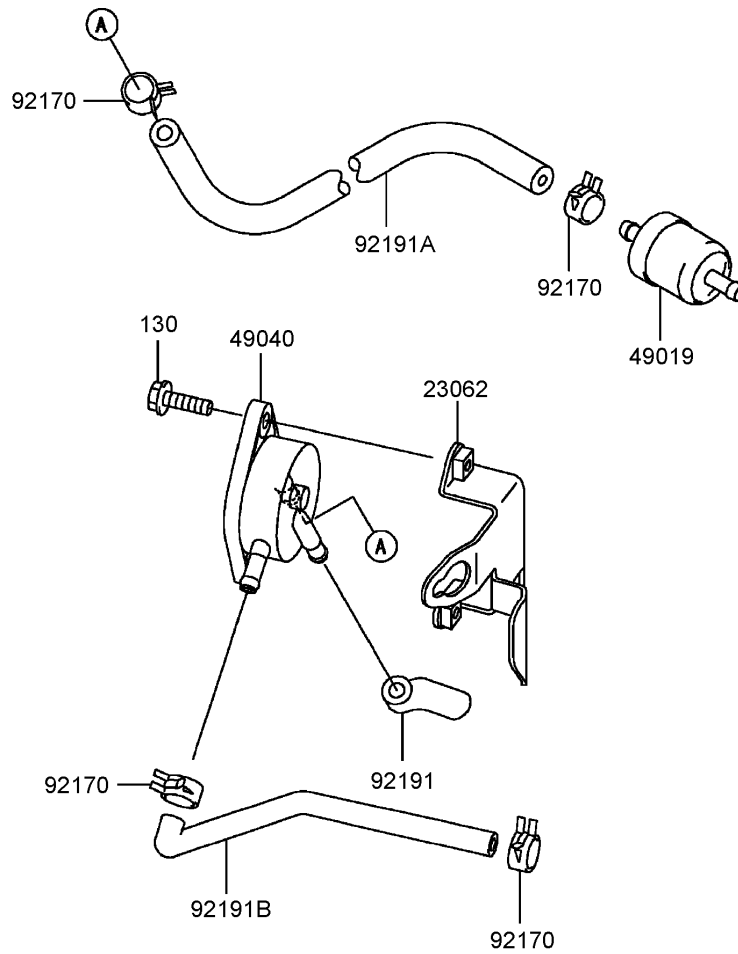

Fuel Tank and Fuel Valve Assembly Kawasaki Model FH430V-AS25

Ref	Part No.	Qty.	Description
●23062	23062-7004-9H	1	Bracket
●49019	49019-7001	1	Filter-Fuel
●49040	49040-7001	1	Pump-Fuel
●92170	92170-2088	1	Clamp
●92191	92191-7002	1	Tube
●92191A	92191-7003	1	Tube (6.35X12.7X160)
●92191B	92191-7004	1	Tube
●130	130B0620	1	Bolt-Flanged

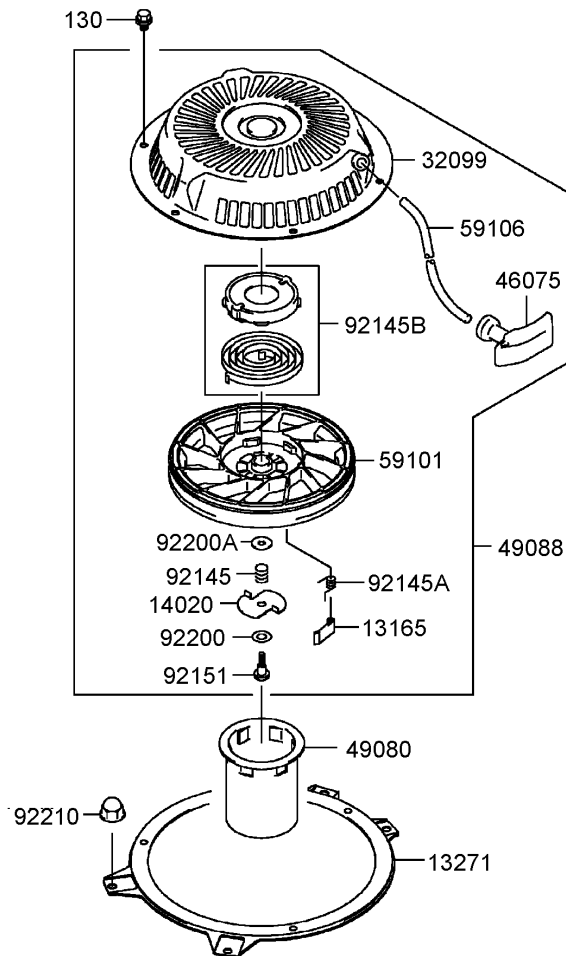

Starter Assembly Kawasaki Model FH430V-AS25

Ref	Part No.	Qty.	Description				
13165	13165-7001	1	Pawl-Starter, Recoil				
13271	13271-7003-9H	1	Plate				
14020	14020-7001	1	Retainer				
32099	32099-7002	1	Case-Recoil, Starter				
46075	46075-7001	1	Grip-Recoil, Starter				
49080	49080-7001	1	Pulley-Starting				
49088	49088-7013	1	Starter-Recoil				
59101	59101-7001	1	Reel-Recoil				
59106	59106-7001	1	Rope				
92145	92145-7006	1	Spring				
92145A	92145-7007	1	Spring				
92145B	92145-7008	1	Spring				
92151	92151-7008	1	Bolt				
92200	92200-7004	1	Washer				
92200A	92200-7005	1	Washer				
92210	92210-0003	1	Nut				
130	130B0608	1	Bolt-Flanged				

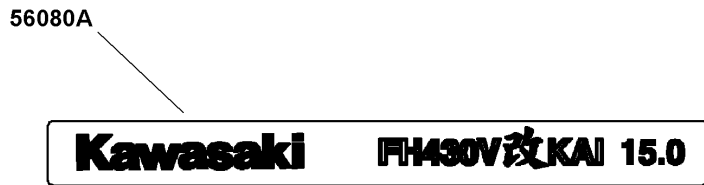
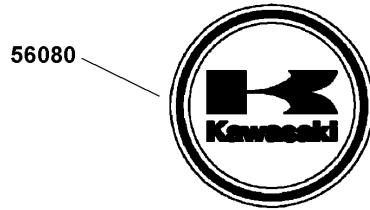
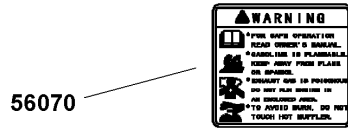
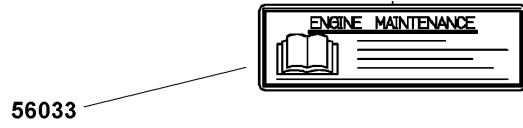

Label Assembly
Kawasaki Model FH430V-AS25

Ref	Part No.	Qty.	Description
⑤56033	56033-7001	1	Label-Manual
⑤56070	56070-7001	1	Label-Warning
⑤56080	56080-2077	1	Label-Brand
⑤56080A	56080-7024	1	Label-Brand

