



Snow Commander[®] Snowthrower

Model No. 38602 - 240000001 and up.

Parts Catalog

Ordering Replacement Parts

To order replacement parts, please supply the part number, the quantity, and the description of each part desired.

Understanding Reference Numbers

Each identified part in an illustration has a reference number. The reference number for a part also appears in the parts list, along with other information about the part.

This catalog uses two special reference number formats, one to indicate parts in a service assembly and another to indicate the quantity of a given part in an illustration.

Service Assembly Reference Numbers

Parts in service assemblies have reference numbers in the form a:b. The a represents the reference number of the entire service assembly and the b represents a sequential number unique to each part within the service assembly.

For example, a wheel assembly might be identified by reference number 6, the tire by 6:1, the valve by 6:2, and the wheel by 6:3. When you order the assembly identified by reference number 6, you receive all parts identified by reference numbers 6:1, 6:2, and 6:3. However, you may also order any part individually. Reference numbers of this type appear in illustrations and in part lists.

Reference Numbers Indicating Quantity

In an illustration, if a reference number indicates more than one part, the reference number has the form nX y. The n represents the quantity of the part, the X is the multiplication symbol, and the y represents the reference number.

For example, in an illustration, the reference number 2X 37 means that two of the parts identified by reference number 37 are indicated.

Contents

Description	Page	Description	Page
Upper Housing and Side Plate Assembly 3	Upper Handle Assembly 10
Lower Housing Assembly 4	Lower Handle Assembly 11
Impeller Drive Assembly 5	Crankcase, Crankshaft, Cylinder Head, and	
Chute Assembly 6	Connecting Rod Assemblies Briggs and 12
Impeller Assembly 7	Stratton 084333-0199-E1	
Engine and Frame Assembly 8	Intake Manifold, Carburetor, and Muffler	
Upper Shroud and Control Panel Assembly 9	Assemblies Briggs and Stratton 084333-0199- E1 13
		Flywheel, Blower Housing, and Starter	
		Assemblies Briggs and Stratton 084333-0199- E1 14

Part Description Abbreviations

Part descriptions in this catalog may include the following abbreviations.

AR. as required	INC. incorporated
ASM. assembly	LH. left hand
BBC. blade brake clutch	NI. nylon insert
CARR. carriage	NPTF. national pipe thread fine
DEG. degrees	PFH. phillips flat head
EXT. external	PPH. phillips pan head
FH. flat head	PPHTF. phillips pan head thread forming
GA. gauge	PRH. phillips round head
HF. hex flange	PTH. phillips truss head
HH. hex head	PTO. power-take-off
HHF. hex head flange	RH. right hand
HHFTF. hex head flange thread forming	ROPS. roll-over-protection-system
HJ. hex jam	SFH. slotted fillister head
HLH. hex lag head	SHH. slotted hex head
HOC. height-of-cut	SHWH. slotted hex washer head
HSBH. hex socket button head	SPH. slotted pan head
HSFH. hex socket flat head	SQH. square head
HSH. hex socket head	SRH. slotted round head
HWH. hex washer head	STD. standard
HWHTF. hex washer head thread forming	TAP. self tapping
HYD. hydraulic	TTH. torx truss head

Footnotes

- ❶ Not illustrated
- ❷ Not serviced separately
- ❸ Obtain from your local Briggs & Stratton dealer

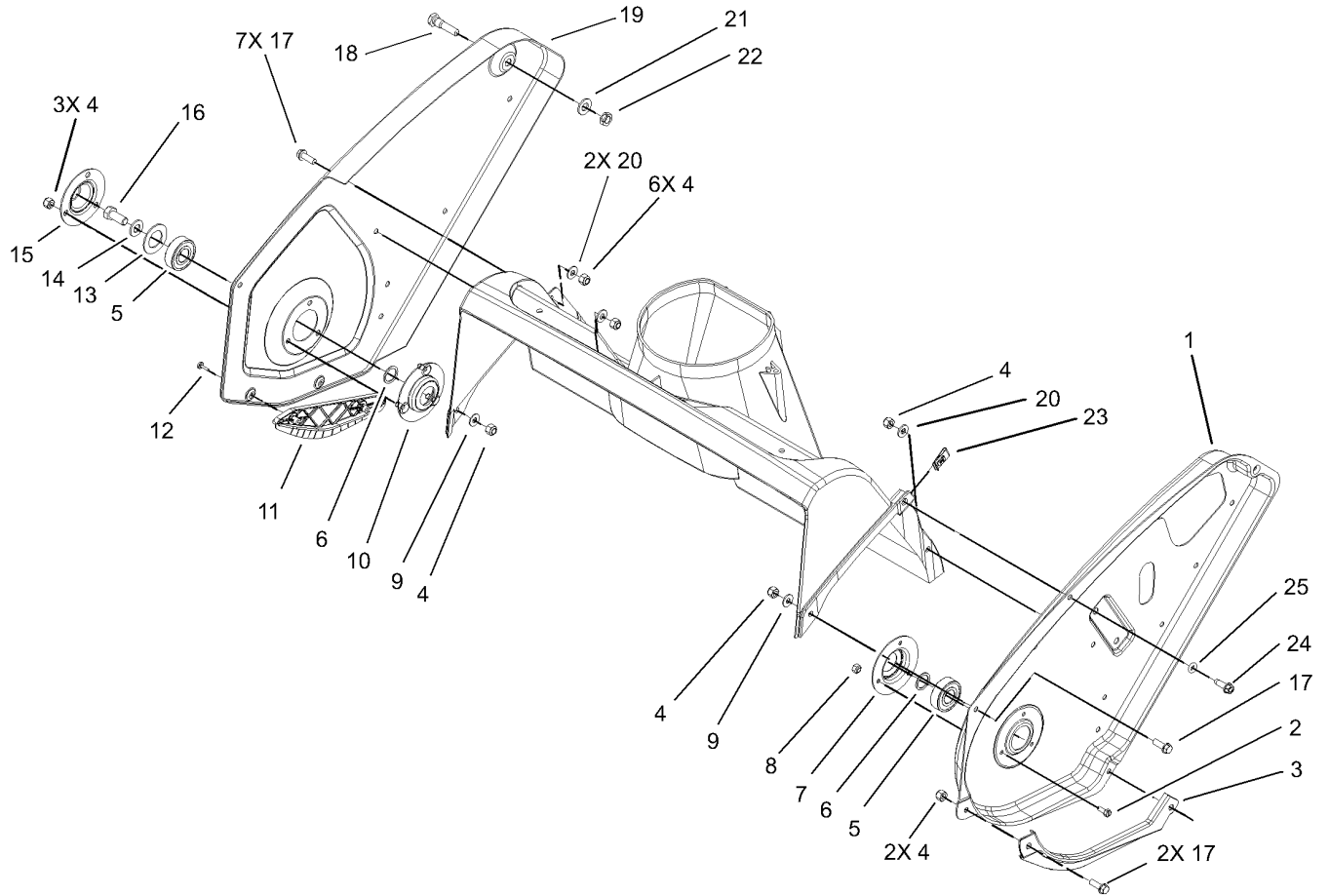

Upper Housing and Side Plate Assembly

Ref	Part No.	Qty.	Description
1	100-9865-03	1	Sideplate-LH
2	32105-8	3	Screw-SHH
3	104-0871	1	Guard-Rotor, LH
4	3296-42	14	Nut-Lock, NI
5	100-1048	2	Bearing-Ball
6	52-7280	2	Washer-Thrust
7	38-8620	1	Flange-Bearing
8	3296-2	3	Nut-Lock
9	3256-1	2	Washer-Flat
10	52-9110	1	Flange-Bearing
11	104-0872	1	Guard-Rotor, RH
12	95-4234	2	Screw-PPH
13	52-7270	1	Washer-Rubber
14	3256-24	1	Washer-Flat
15	52-7290-03	1	Retainer-Bearing
16	3234-25	1	Screw-HHF
17	32105-15	10	Screw
18	38-8211	1	Pin-Rotor
19	100-9870-03	1	Sideplate-RH
20	3256-22	3	Washer-Flat
21	3256-24	1	Washer-Flat
22	32152-8	1	Nut-Lock, Cone
23	702552	1	Nut-Speed
24	49-2040	1	Screw-HWHTF

Ref	Part No.	Qty.	Description
25	104-8657	1	O-Ring

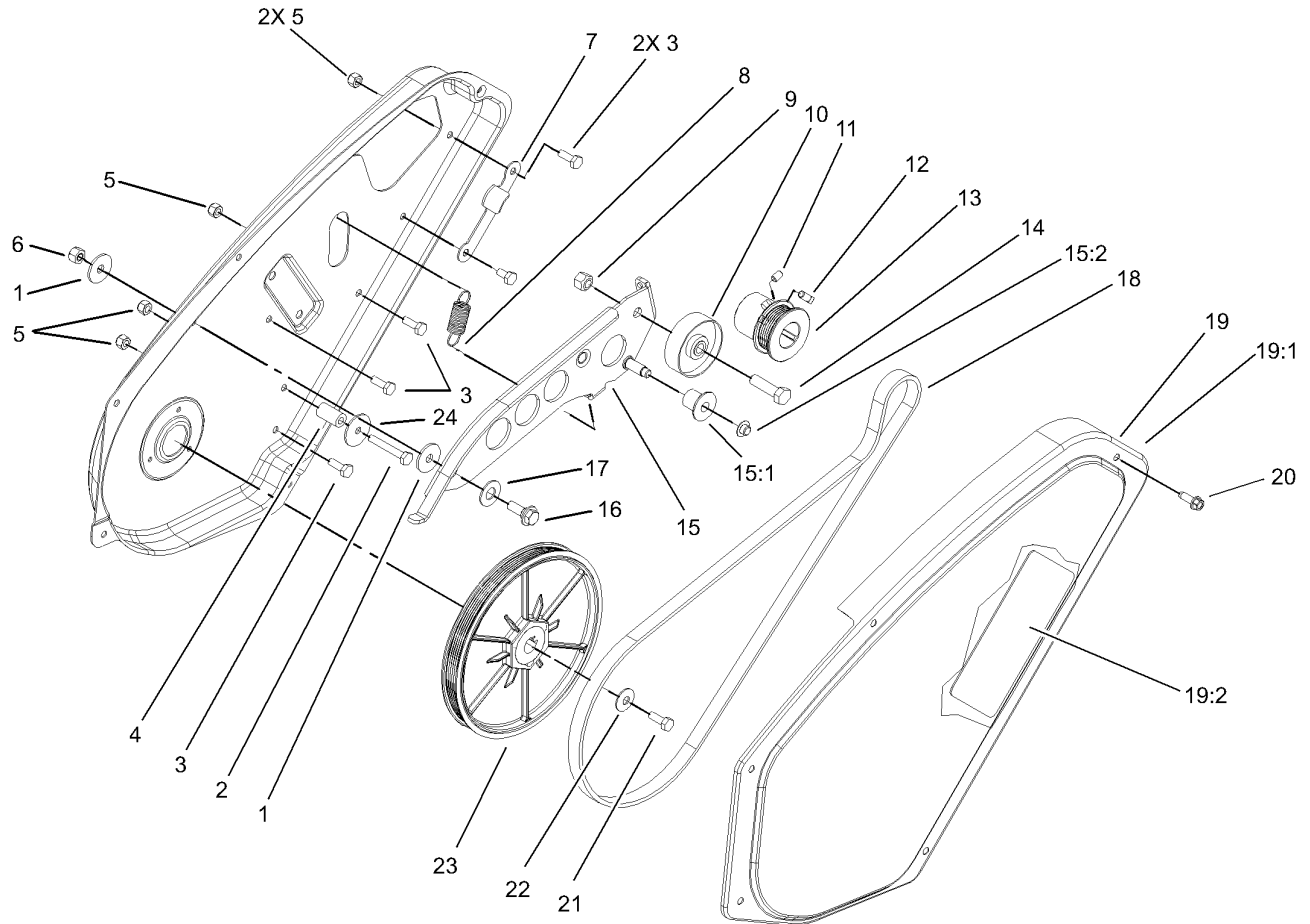

Impeller Drive Assembly

Ref	Part No.	Qty.	Description
1	5-4460	2	Washer-Pivot
2	321-10	1	Screw-HH
3	321-4	5	Screw-HH
4	55-9530	1	Sleeve-Guide, Belt
5	3296-42	5	Nut-Lock, NI
6	3296-29	1	Nut-Lock, NI
7	104-0868	1	Belt-Guide
8	104-0869	1	Spring-Brake
9	32152-2	1	Nut-Lock, Cone
10	55-9290	1	Pulley-Idler
11	3245-41	1	Screw-HSH
12	3241-7	1	Screw-SQH
13	104-4108	1	Pulley
14	323-29	1	Screw-HH
15	104-4113	1	Brake-Arm
15:1	104-4114	1	Roller-Brake
15:2	32112-11	1	Nut-Push
16	27-0410	1	Screw-Shoulder
17	25-5640	1	Washer
18	104-0851	1	Belt-Drive
19	104-4140	1	Drive Cover ASM
19:1	104-2767	1	Decal-Warning
19:2	104-4125	1	Decal-Belt Routing
20	49-2040	1	Screw-HWHTF

Ref	Part No.	Qty.	Description
21	321-30	1	Screw-HH
22	3290-456	1	Washer-Belleville
23	100-9871	1	Pulley-Rotor
24	3256-55	1	Washer-Flat

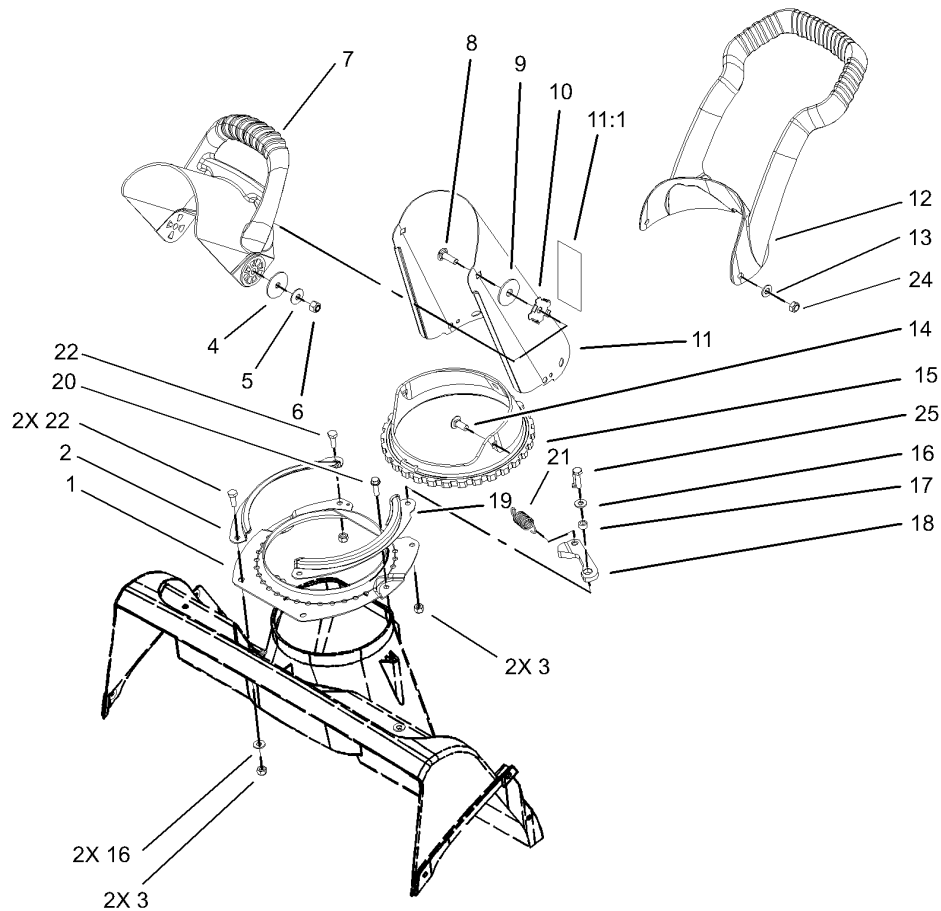

Chute Assembly

Ref	Part No.	Qty.	Description
1	55-8921-03	1	Ring-Support, Chute
2	71-4990-03	1	Retainer-Chute, RH
3	3296-42	4	Nut-Lock, NI
4	3256-68	2	Washer-Flat
5	3290-456	2	Washer-Belleville
6	3296-29	2	Nut-Lock, NI
7	104-0882	1	Chute-Deflector
8	3230-22	2	Screw-CARR
9	20-4320	2	Washer-Rubber
10	55-8950	2	Plate-Friction
11	104-4115	1	Chute ASM
11:1	104-4135	1	Decal-Danger
12	104-0884	1	Handle-Control, Chute
13	3256-70	3	Washer-Flat
14	100-5487	3	Screw-PTH
15	104-2763	1	Ring-Chute
16	3256-22	3	Washer-Flat
17	55-9370	1	Spacer-Blade, Rotor
18	80-4610	1	Detent
19	71-4980-03	1	Retainer-Chute, LH
20	46-8091	1	Screw-HWH
21	80-4600	1	Spring-Extension
22	321-4	3	Screw-HH
24	3296-47	3	Nut-Lock, NI

Ref	Part No.	Qty.	Description
25	321-6	1	Screw-HH

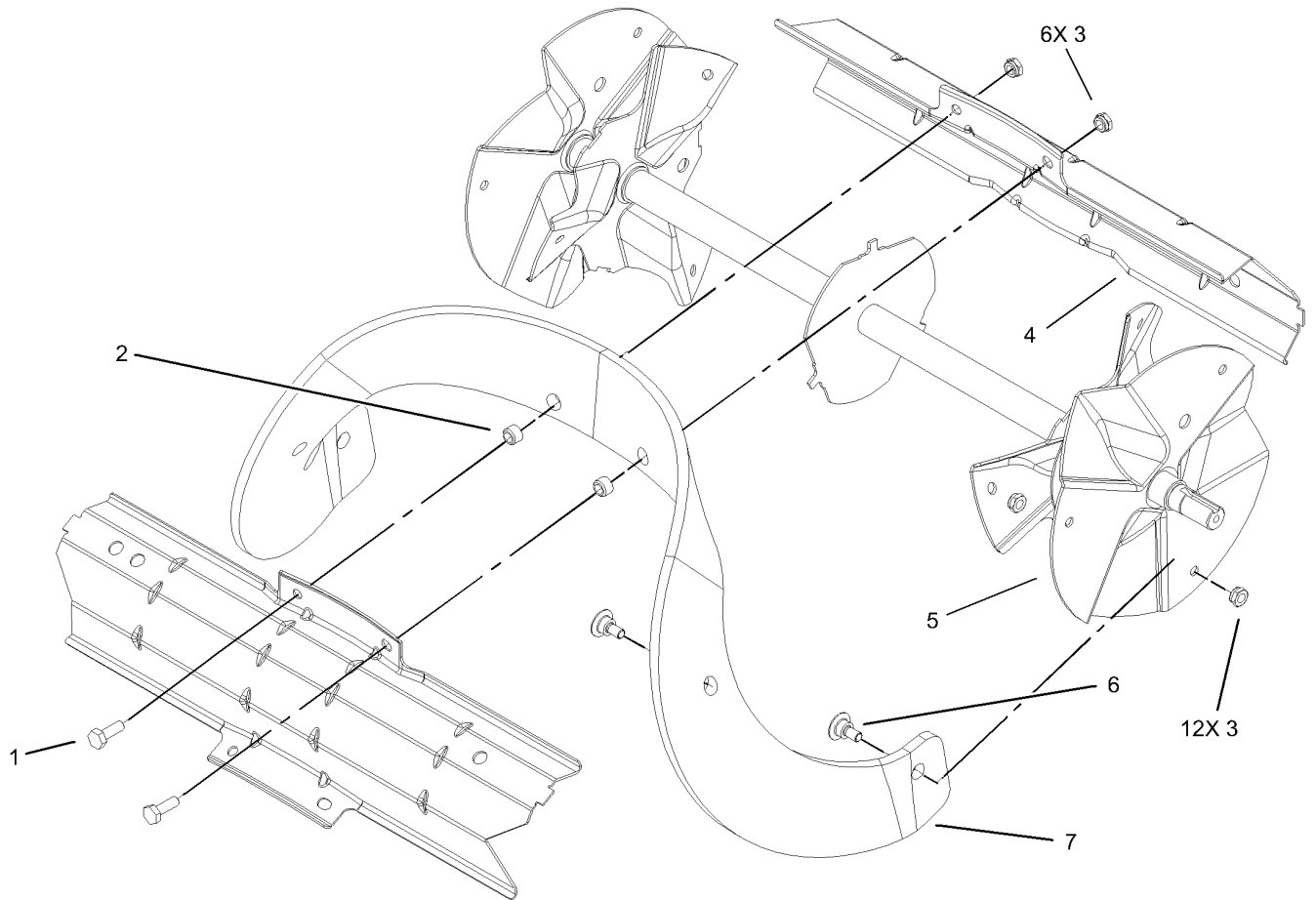

Impeller Assembly

Ref	Part No.	Qty.	Description
1	321-4	6	Screw-HH
2	55-9370	6	Spacer-Blade, Rotor
3	3296-56	18	Nut-Lock, NI
4	100-9856-03	3	Drum-Rotor
5	100-9877-03	1	Rotor ASM
6	84-1971	12	Screw
7	100-9872	3	Blade-Rotor

--	--	--	--

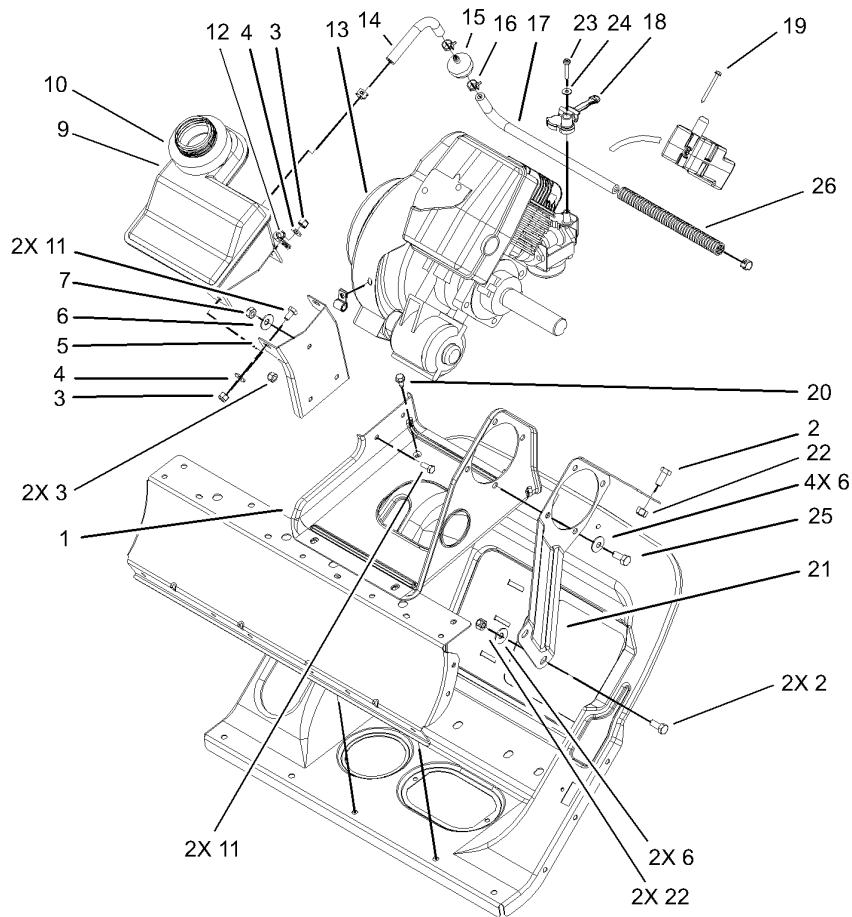

Engine and Frame Assembly

Ref	Part No.	Qty.	Description
1	105-3515-03	1	Support-Engine
2	322-3	3	Screw-HH
3	3296-42	4	Nut-Lock, NI
4	3256-22	2	Washer-Flat
5	100-9899-03	1	Support-Recoil
6	3290-456	7	Washer-Belleville
7	3296-42	1	Nut-Lock, NI
9	105-8953	1	Tank-Gas
10	55-9310	1	Seal-Foam
11	321-2	4	Screw-HH
12	2412-91	1	Clamp
13		1	Engine-Briggs And Stratton, 084333-0199-E1
14	94-9932	1	Hose-Fuel
15	56-6360	1	Filter-Fuel
16	2412-98	4	Clamp
17	49-2482	1	Line-Fuel
18	104-0878	1	Lever-Choke
19	32144-27	3	Screw
20	32144-44	3	Screw-HWH
21	104-0875-03	1	Brace-Engine
22	3296-29	3	Nut-Lock, NI
23	32144-97	1	Screw-PPH, Plastite
24	104-4143	1	Washer

Ref	Part No.	Qty.	Description
25	322-4	4	Screw-HH
26	104-4149	1	Conduit
1	106-4741	1	Cord-Electric

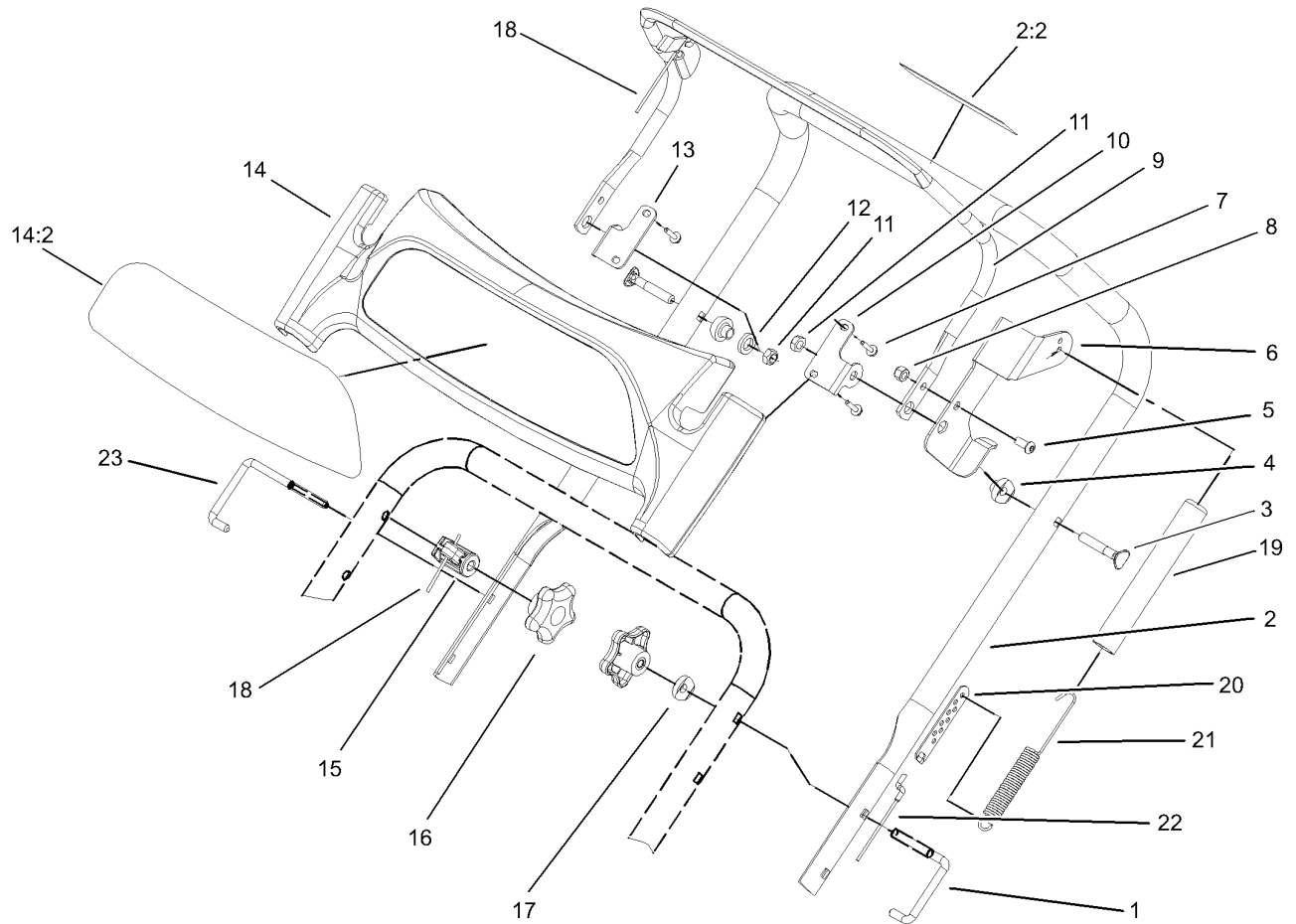

Upper Handle Assembly

Ref	Part No.	Qty.	Description
1	98-2266	1	Lock-Handle
2	104-4137	1	Upper Handle ASM
2:2	104-2775	1	Decal-Drive, Rotor
3	92-2260	2	Screw-Handle
4	55-9340	2	Spacer-Bar, Control
5	3274-31	1	Screw-HSBH
6	100-9882-03	1	Arm-Clutch, Handle
7	98-1375	4	Screw-HWH
8	3296-42	1	Nut-Lock, NI
9	104-4104-03	1	Bar-Control
10	104-4100	1	Bracket-Panel, LH
11	3296-47	2	Nut-Lock, NI
12	55-9670	1	Washer
13	104-4101	1	Bracket-Panel, RH
14	106-4737	1	Display Handle Panel ASM
14:2	106-4716	1	Decal-Handle Display
15	100-9868	1	Guide-Pivot Cable
16	106-4161	2	Knob-Handle
17	75-9130	1	Washer-Curved
18	104-0895	1	Cable-Pivot
19	104-4145	1	Cover-Spring
20	71-5330	1	Adjuster-Cable, Clutch
21	104-0894	1	Spring-Cable
22	104-0896	1	Cable-Clutch

Ref	Part No.	Qty.	Description
23	104-4126	1	Lock-Handle, RH

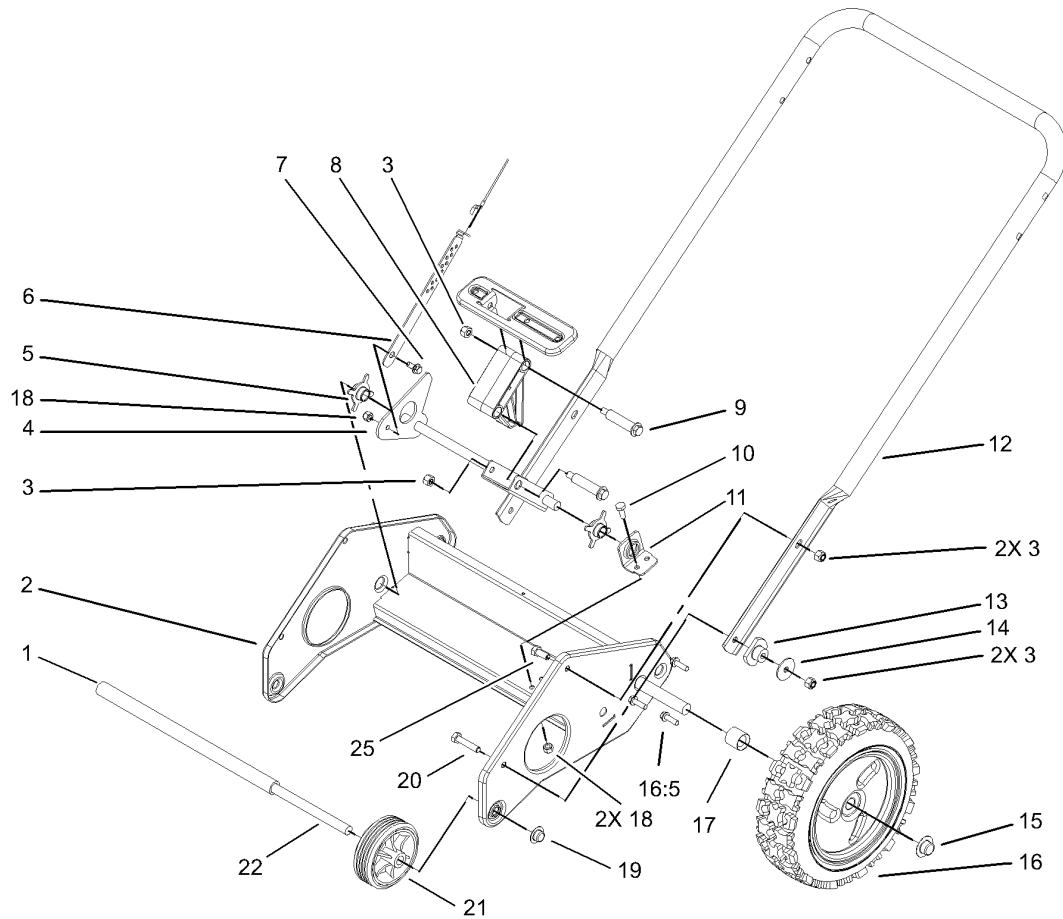

Lower Handle Assembly

Ref	Part No.	Qty.	Description
1	100-9878	1	Spacer-Plastic
2	100-9887-03	1	Wheelframe ASM
3	3296-29	6	Nut-Lock, NI
4	104-0853	1	Pivot ASM
5	104-0855	2	Bushing-Rod, Pivot
6	104-0899	1	Adjuster-Cable, Pivot
7	104-4102	1	Screw-Shoulder
8	100-9896	1	Block-Pivot
9	100-9880	2	Bolt-Shoulder
10	321-4	2	Screw-HH
11	100-9879	1	Support-Rod, Pivot
12	100-9890-03	1	Handle-Lower
13	100-9883	2	Bushing-Pivot
14	3256-57	2	Washer-Flat
15	104-4111	2	Nut-Push
16	105-3549	2	Wheel ASM
16:5	46-8091	3	Screw-HWH
17	104-0892	2	Spacer-Axle, Rear
18	3296-42	3	Nut-Lock, NI
19	32112-14	2	Nut-Push
20	322-7	2	Screw-HH
21	100-9864	2	Tire And Wheel ASM
22	100-9875	1	Axle-Front
25	322-3	2	Screw-HH

--	--	--	--

1036 EMISSIONS LABEL

48 Short Block

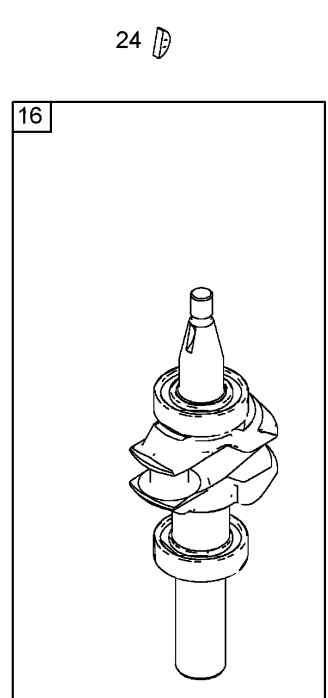
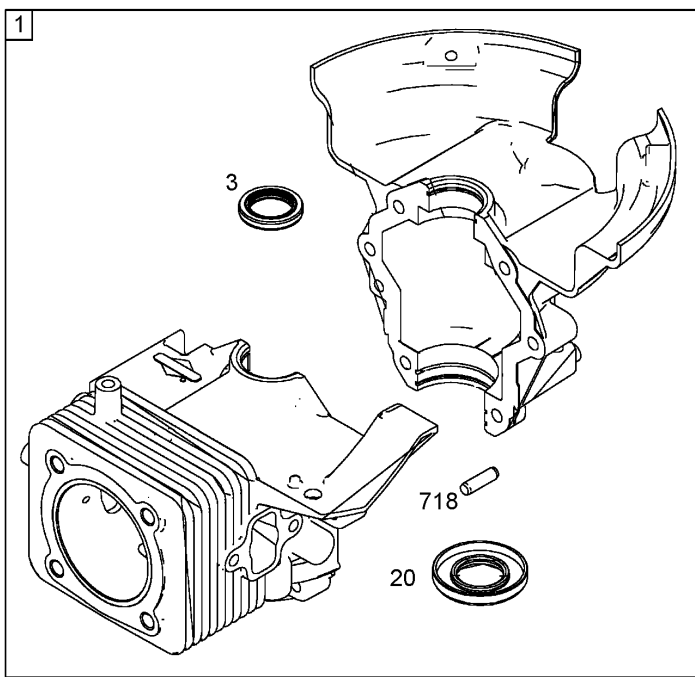
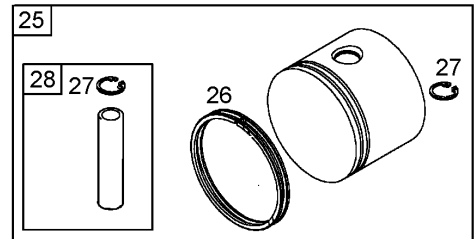
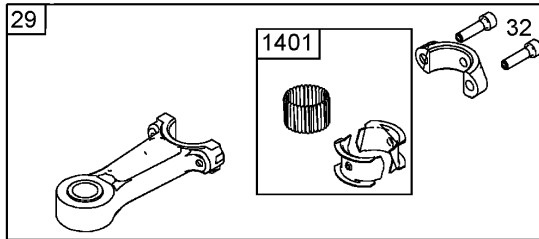
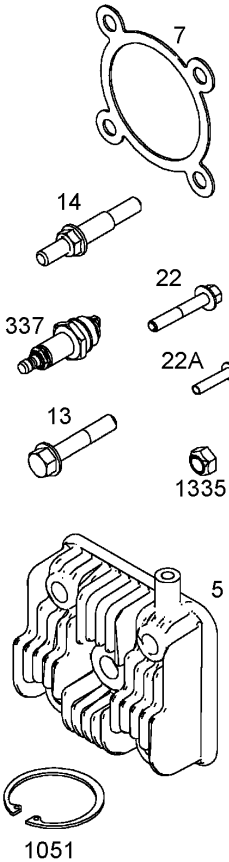

Crankcase, Crankshaft, Cylinder Head, and Connecting Rod Assemblies Briggs and Stratton 084333-0199-E1

Ref	Part No.	Qty.	Description
1	801321	1	Cylinder ASM
3	801262	1	Seal-Oil
5	801283	1	Head-Cylinder
7	801263	1	Gasket-Head, Cylinder
13	801264	1	Screw (Cylinder Head)
14	801265	1	Stud (Cylinder Head)
16	801221	1	Crankshaft
20	801261	1	Seal-Oil
22	801266	1	Screw (Crankcase Cover And Sump)
22A	801271	1	Screw (Crankcase Cover And Sump)
24	801234	1	Key-Flywheel
25	801281	1	Piston ASM
26	801282	1	Ring Set
27	801275	1	Lock-Pin, Piston
28	801276	1	Pin-Piston
29	801277	1	Rod-Connecting
32	801278	1	Screw
48	801287	1	Short Block
337	801254	1	Plug-Spark
718	690959	1	Pin-Locating
1036	801295	1	Label-Emissions
1051	801274	1	Ring-Retaining

Ref	Part No.	Qty.	Description
1335	801269	1	Nut (Blower Housing)
1401	801290	1	Roller-Strip

NOTES

