



## Power Max 6000 Snowthrower

Model No. 38610 - 260000001 and up.

### Parts Catalog

---

#### Ordering Replacement Parts

To order replacement parts, please supply the part number, the quantity, and the description of each part desired.

#### Understanding Reference Numbers

Each identified part in an illustration has a reference number. The reference number for a part also appears in the parts list, along with other information about the part.

This catalog uses two special reference number formats, one to indicate parts in a service assembly and another to indicate the quantity of a given part in an illustration.

#### Service Assembly Reference Numbers

Parts in service assemblies have reference numbers in the form a:b. The a represents the reference number of the entire service assembly and the b represents a sequential number unique to each part within the service assembly.

For example, a wheel assembly might be identified by reference number 6, the tire by 6:1, the valve by 6:2, and the wheel by 6:3. When you order the assembly identified by reference number 6, you receive all parts identified by reference numbers 6:1, 6:2, and 6:3. However, you may also order any part individually. Reference numbers of this type appear in illustrations and in part lists.

#### Reference Numbers Indicating Quantity

In an illustration, if a reference number indicates more than one part, the reference number has the form nX y. The n represents the quantity of the part, the X is the multiplication symbol, and the y represents the reference number.

For example, in an illustration, the reference number 2X 37 means that two of the parts identified by reference number 37 are indicated.

# Contents

Description	Page	Description	Page
Auger and Housing Assembly	..... 3	Lever Chute Control Assembly	..... 11
26in Auger Gearcase Assembly No. 108-7328	..... 4	Engine and Frame Assembly	..... 12
Chute Assembly	..... 5	Crankcase, Crankshaft, Cylinder Head, and Connecting Rod Assemblies Briggs and Stratton 084333-0197-E1	..... 13
Chain Drive Assembly	..... 6	Intake Manifold, Carburetor, and Muffler Assemblies Briggs and Stratton 084333-0197-E1	..... 14
Frame Assembly	..... 7	Flywheel, Blower Housing, and Starter Assemblies Briggs and Stratton 084333-0197-E1	..... 15
Control Panel Assembly	..... 9	Attachments and Accessories List	..... 16
Handle and Control Assembly	..... 10		

## Part Description Abbreviations

Part descriptions in this catalog may include the following abbreviations.

AR. .... as required	INC. .... incorporated
ASM. .... assembly	LH. .... left hand
BBC. .... blade brake clutch	NI. .... nylon insert
CARR. .... carriage	NPTF. .... national pipe thread fine
DEG. .... degrees	PFH. .... phillips flat head
EXT. .... external	PPH. .... phillips pan head
FH. .... flat head	PPHTF. .... phillips pan head thread forming
GA. .... gauge	PRH. .... phillips round head
HF. .... hex flange	PTH. .... phillips truss head
HH. .... hex head	PTO. .... power-take-off
HHF. .... hex head flange	RH. .... right hand
HHFTF. .... hex head flange thread forming	ROPS. .... roll-over-protection-system
HJ. .... hex jam	SFH. .... slotted fillister head
HLH. .... hex lag head	SHH. .... slotted hex head
HOC. .... height-of-cut	SHWH. .... slotted hex washer head
HSBH. .... hex socket button head	SPH. .... slotted pan head
HSFH. .... hex socket flat head	SQH. .... square head
HSH. .... hex socket head	SRH. .... slotted round head
HWH. .... hex washer head	STD. .... standard
HWHTF. .... hex washer head thread forming	TAP. .... self tapping
HYD. .... hydraulic	TTH. .... torx truss head

## Footnotes

- ❶ Not illustrated
- ❷ Not serviced separately
- ❸ Obtain from your local Briggs & Stratton dealer

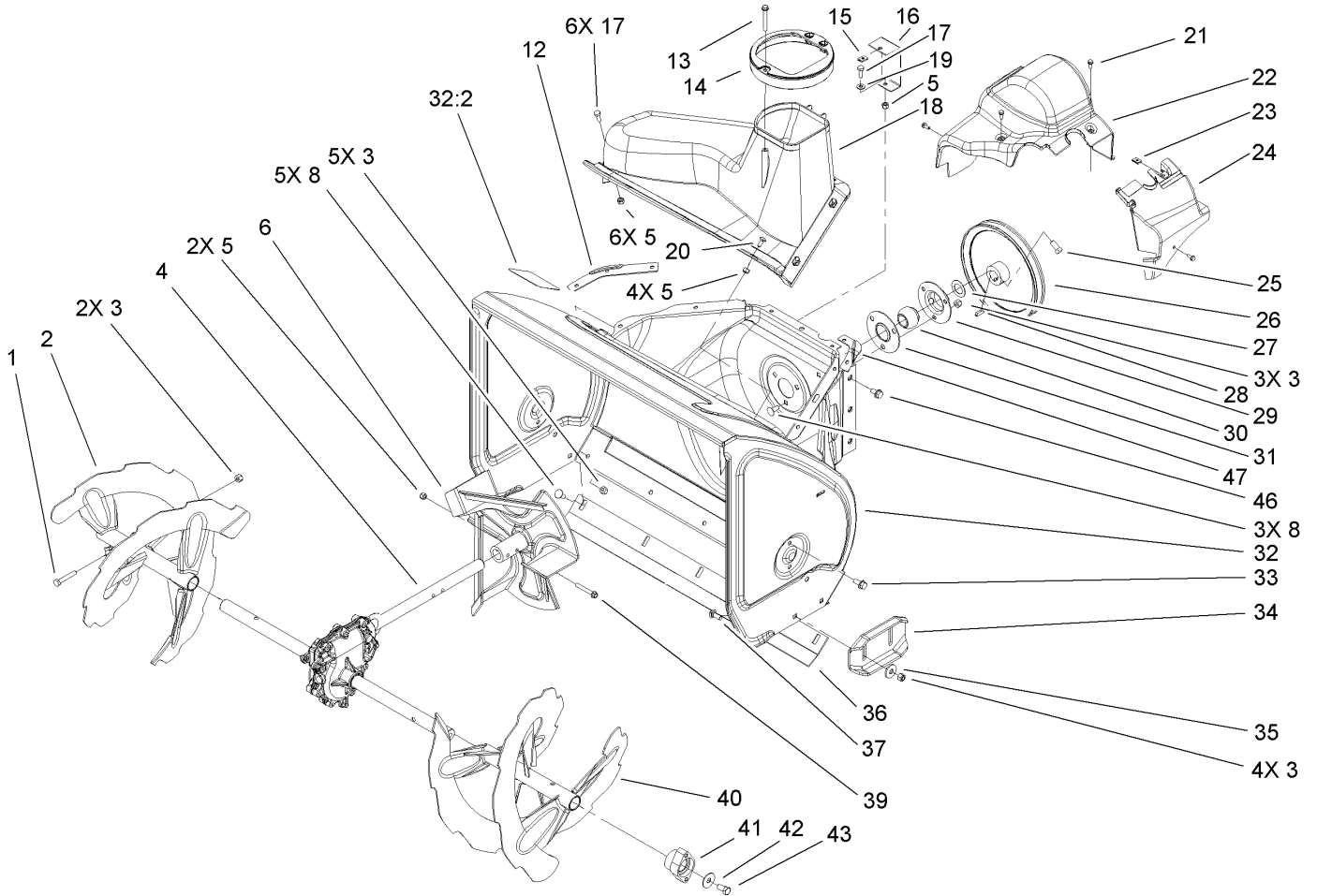

## Auger and Housing Assembly

Ref	Part No.	Qty.	Description
1	322-21	2	Screw-HH
2	106-7289-03	1	RH Auger ASM
3	3296-29	14	Nut-Lock, NI
4	108-7328	1	26 Inch Auger Gearcase ASM
5	3296-42	13	Nut-Lock, NI
6	106-4576-03	1	Impeller ASM
8	3230-23	8	Screw-CARR
12	107-1017-03	1	Seal-Flange, Cover
13	107-3003	1	Screw-Plastite
14	107-3006	1	Guide-Chute
15	107-1013	1	Nut-Speed, U-Type
16	107-1014-03	1	Bracket-Cover, Clip Nut
17	321-4	7	Screw-HH
18	108-0017	1	Cover
19	3256-22	1	Washer-Flat
20	3229-1	4	Screw-CARR
21	32144-112	4	Screw-HWH
22	107-1001	1	Cover-Belt
23	701493	1	Nut-Speed
24	107-1016	1	Cover-Extension, Belt
25	3242-4	2	Screw-Set, SQH
26	62-1300	1	Pulley-Impeller
27	252-80	1	Washer-Thrust
28	3257-23	1	Key-Woodruff

Ref	Part No.	Qty.	Description
29	26-6110	1	Flange-Cup, Bearing
30	63-3450	1	Bearing-Ball
31	26-6120	1	Flange-Cup, Bearing
32	107-3821	1	26 Inch Auger Housing ASM
32:2	53-7670	1	Decal-Warning, Auger
33	32144-70	4	Screw-HH
34	106-4588-01	2	Skid
35	52-2861	4	Washer
36	105-9976-01	1	Scraper-Fixed
37	3230-16	4	Screw-CARR
39	321-44	2	Screw-HHF
40	106-7299-03	1	LH Auger ASM
41	106-4570	2	Auger-Bearing
42	3-0750	2	Washer
43	323-4	2	Screw-HH
46	32144-14	6	Screw-HWH
47	108-0039-03	1	Seal
99	281-1	1	Plug-Pipe, SQH

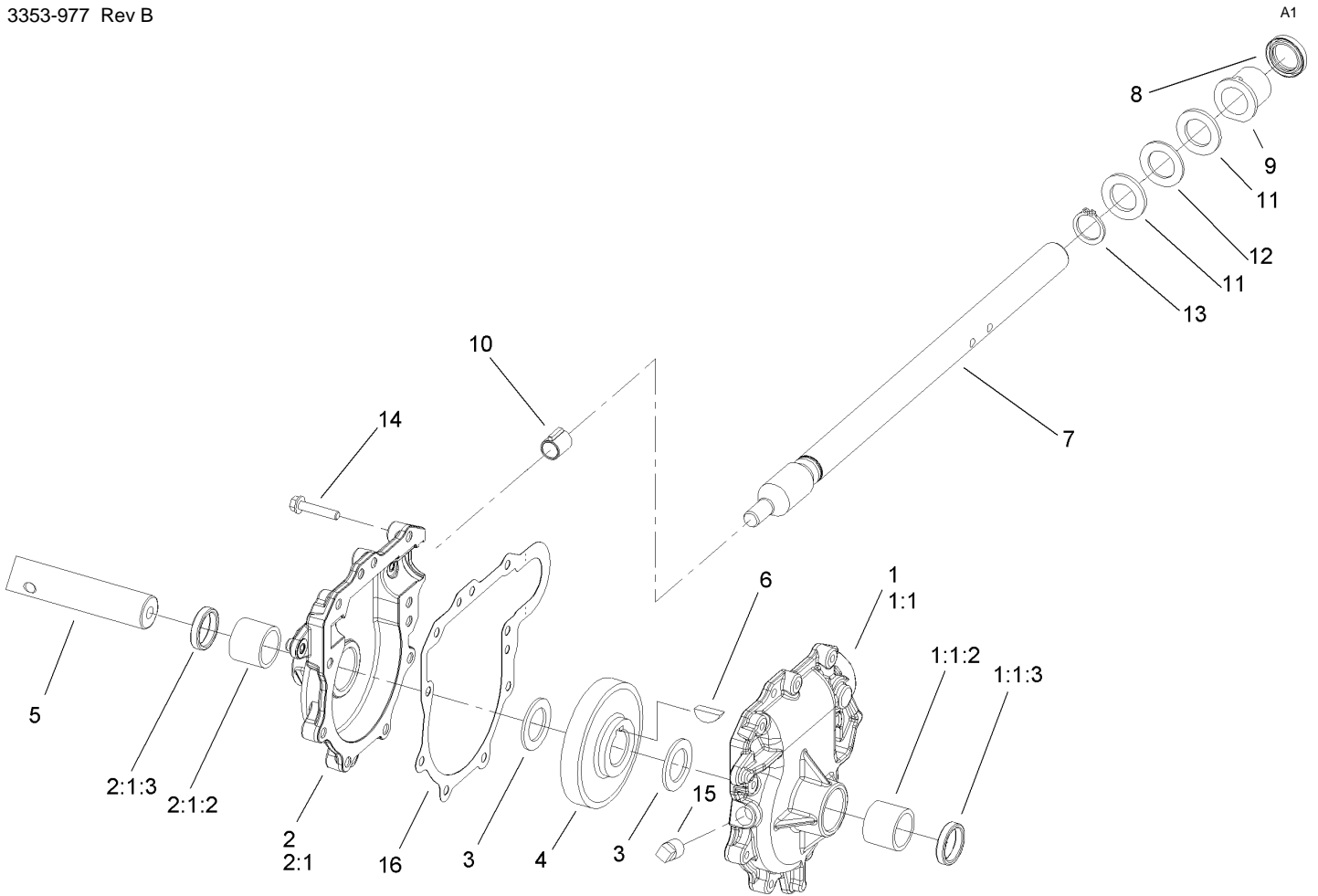

## 26in Auger Gearcase Assembly No. 108-7328

Ref	Part No.	Qty.	Description
1	108-7325	1	LH Auger Gearcase ASM
②1:1		1	Gearcase-Auger, LH
1:1:2	256-237	1	Bushing
1:1:3	7-0045	1	Seal-Oil
2	108-7327	1	RH Auger Gearcase ASM
②2:1		1	Gearcase-Auger, RH
2:1:2	256-237	1	Bushing
2:1:3	7-0045	1	Seal-Oil
3	252-71	2	Washer-Thrust
4	62-0120	1	Gear-Helical
5	106-4579	1	Shaft-Auger
6	3257-10	1	Key-Woodruff
7	66-7811	1	Shaft-Impeller
8	253-149	1	Seal-Oil
9	37-6560	1	Bushing-Input
10	62-1150	1	Bushing-Worm
11	252-78	2	Bearing-Thrust
12	252-76	1	Bearing-Thrust
13	32151-33	1	Ring-Retaining, EXT
14	108-4862	9	Screw-HWHTF
15	281-1	1	Plug-Pipe, SQH
16	108-7330	1	Gasket-Gearcase, Auger

Ref	Part No.	Qty.	Description

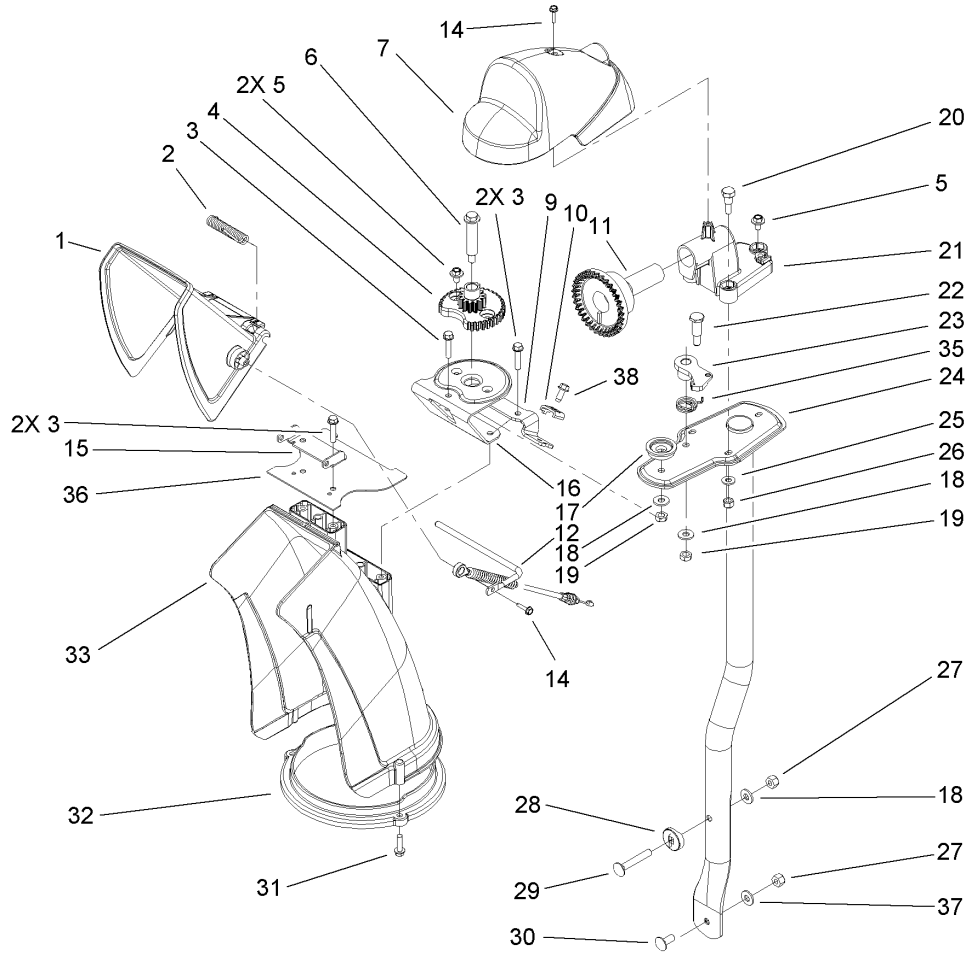

## Chute Assembly

Ref	Part No.	Qty.	Description
1	106-4587	1	Deflector-Chute
2	106-4594	1	Spring-Torsion
3	46-8092	5	Screw-Plastite
4	106-4472	1	Gear-Chute
5	46-6810	3	Screw And Washer ASM
6	100-9880	1	Bolt-Shoulder
7	106-4585	1	Cover-Gear, Chute
9	106-7296	1	Bracket-Cable, Clamp
10	106-7297	1	Clamp-Cable
11	106-4471	1	Gear-Face
12	107-1021	1	Rod-Deflector
14	98-1375	2	Screw-HWH
15	106-7266	1	Bracket-Deflector
16	106-4582-03	1	Bracket-Support, Chute
17	106-4422	1	Spacer-Chute
18	3256-2	3	Washer-Flat
19	3296-47	2	Nut-Lock, NI
20	106-7276	3	Screw-Shoulder
21	106-7257	1	Mount-Gear, Face
22	63-2650	1	Screw-Shoulder
23	106-4476	1	Latch-Chute
24	106-7253-03	1	Tube-Support
25	3256-22	3	Washer-Flat
26	3296-42	3	Nut-Lock, NI

Ref	Part No.	Qty.	Description
27	3296-29	2	Nut-Lock, NI
28	106-7260	1	Washer-Curved
29	3230-5	1	Screw-CARR
30	3230-23	1	Screw-CARR
31	46-8091	3	Screw-HWH
32	105-9991	1	Ring-Chute
33	106-4440	1	Chute-Discharge
35	108-7315	1	Spring-Torsion
36	108-5052	1	Seal-Chute
37	3290-456	1	Washer-Belleville
38	32144-10	1	Screw-HWH

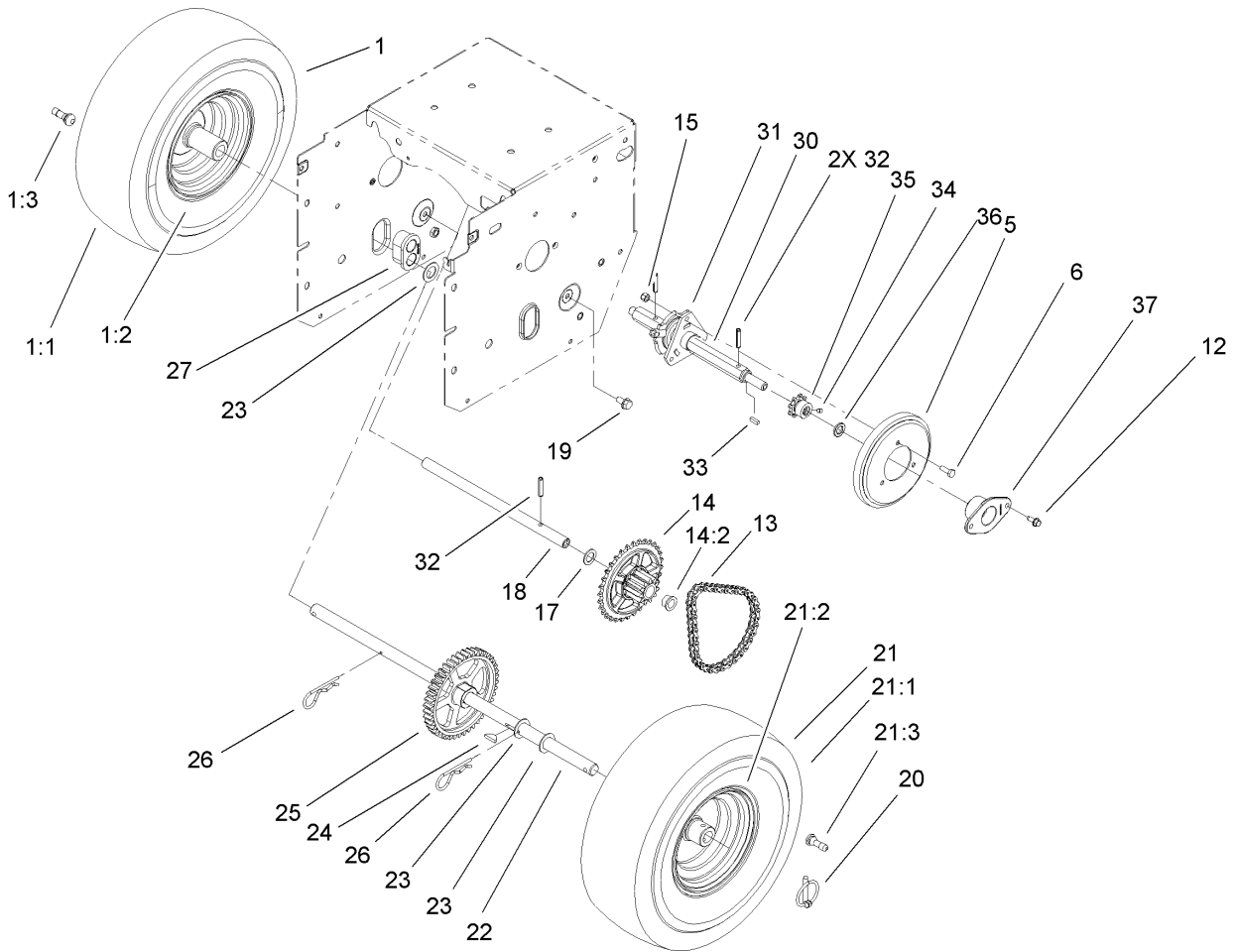

## Chain Drive Assembly

Ref	Part No.	Qty.	Description
①		1	RH Wheel And Tire ASM
1:1	107-3042	1	Tire
1:2	107-3043	1	Rim-Tire
1:3	232-27	1	Stem-Valve
5	106-4480	1	Wheel-Friction
6	321-4	3	Screw-HH
12	32144-10	4	Screw-HWH
13	108-0016	1	Chain-Roller
13	2710-6	1	Link-Connecting
14	108-0013	1	Sprocket ASM
14:2	108-2974	2	Bushing-Flange
15	3296-42	3	Nut-Lock, NI
17	107-3041	1	Washer-Flat
18	106-4592	1	Shaft-Intermediate
19	32144-14	2	Screw-HWH
20	107-3039	2	Klik Pin ASM
②		1	LH Wheel And Tire ASM
21:1	107-3042	1	Tire
21:2	107-3043	1	Rim-Tire
21:3	232-27	1	Stem-Valve
22	106-4449	1	Shaft-Axle
23	3-8664	3	Washer-Thrust
24	3257-7	1	Key-Woodruff
25	106-4572	1	Gear-Axle, 44 Tooth

Ref	Part No.	Qty.	Description
26	3290-343	2	Pin-Hair
27	106-4558	2	Bearing-Axle
30	108-5054	1	Shaft-Hex
31	106-4434	1	Trunion-Hex
32	32121-9	3	Pin-Roll, Slotted
33	94-8850	1	Key-Square
34	3245-32	2	Screw-HSH
35	106-7317	1	Sprocket-8 Tooth
36	108-5059	1	Spacer-Bushing
37	108-7319	2	Retainer-Bearing

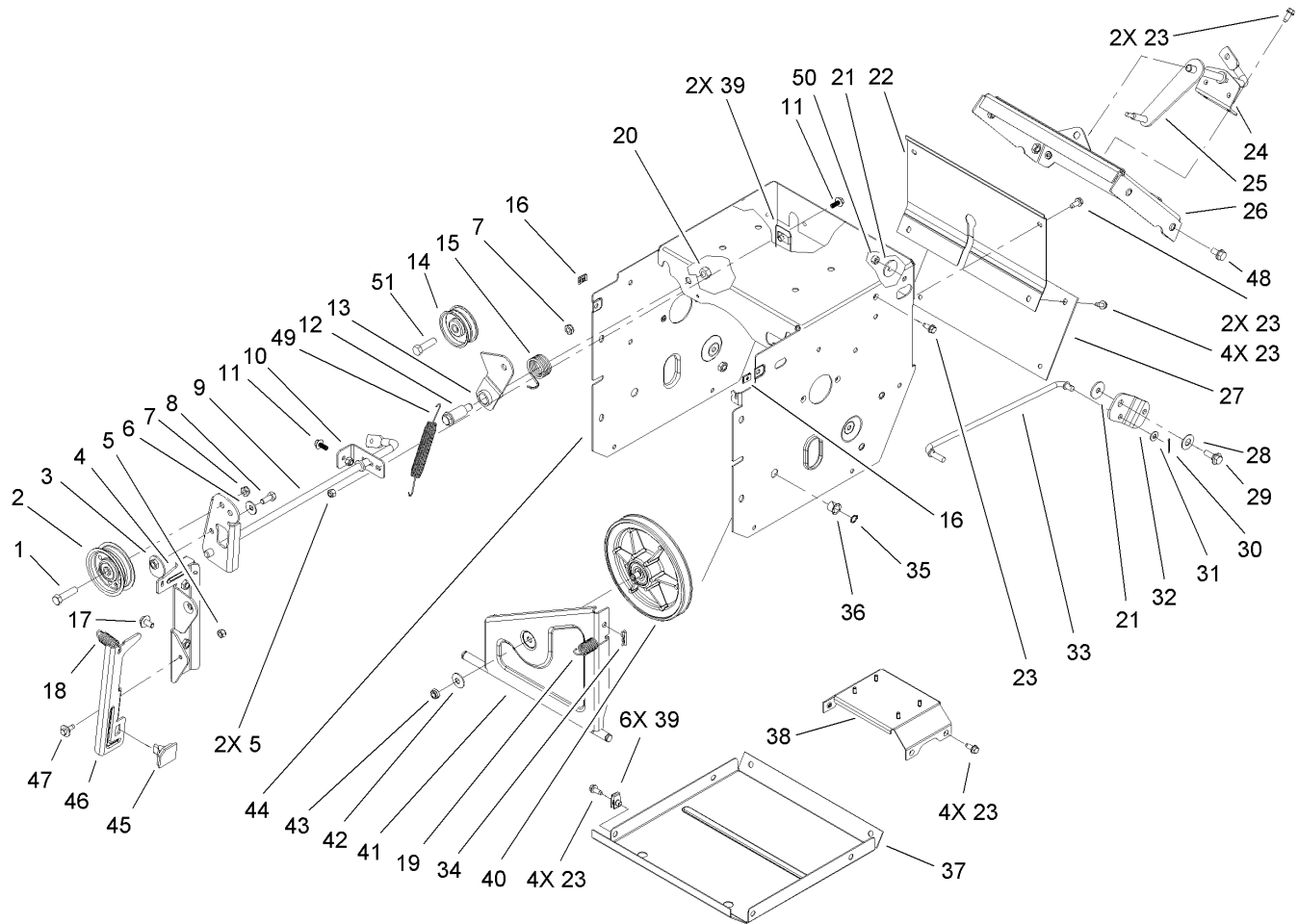

## Frame Assembly

Ref	Part No.	Qty.	Description
1	323-8	1	Screw-HH
2	92-7104	1	Pulley-Idler
3	107-1047	1	Nut
4	107-1039	1	Bracket-Idler, Impeller
5	3296-42	3	Nut-Lock, NI
6	3290-456	1	Washer-Belleveille
7	3296-59	2	Nut-Lock, NI
8	322-3	1	Screw-HH
9	107-3838-03	1	Impeller Clutch ASM
10	106-7341	1	Bracket-Rear, Clutch
11	99-6810	2	Screw-HH
12	108-5056	1	Bolt-Shoulder
13	108-5058	1	Arm-Idler, Traction
14	3-4244	1	Pulley-Idler
15	108-7332	1	Spring-Torsion
16	107-1013	2	Nut-Speed, U-Type
17	3234-7	2	Screw-HHF
18	107-1045	1	Spring-Extension
19	107-1003	1	Spring-Extension
20	3296-76	1	Nut-Lock, NI
21	5-4460	2	Washer-Pivot
22	106-4556-01	1	Cover-Upper
23	32144-10	17	Screw-HWH
24	108-0036	1	Bracket-Rod, Shift

Ref	Part No.	Qty.	Description
25	106-7268	1	Lever-Control, Traction
26	108-0026-01	1	Shift Plate ASM
27	106-7345-01	1	Cover-Lower
28	25-5640	1	Washer
29	27-0410	1	Screw-Shoulder
30	3272-4	1	Pin-Cotter
31	3256-23	1	Washer-Flat
32	107-1011	1	Bellcrank-Drive
33	106-4467	1	Link-Control, Speed
34	3290-307	1	Pin-Hair
35	32151-61	2	Ring-Retaining
36	256-257	2	Bushing-Nyliner
37	106-7330-01	1	Pan-Bottom
38	106-9189	1	Frame Brace ASM
39	107069	8	Clip
40	108-0031	1	Traction Pulley ASM
41	108-7307	1	Friction Wheel Bracket ASM
42	3290-340	1	Washer-Belleveille
43	3296-5	1	Nut-Lock
44	108-0019-01	1	Traction Frame ASM
45	66-8060	1	Pad-Brake
46	107-1000	1	Arm-Brake
47	92-9698	1	Screw-Shoulder
48	32144-14	4	Screw-HWH



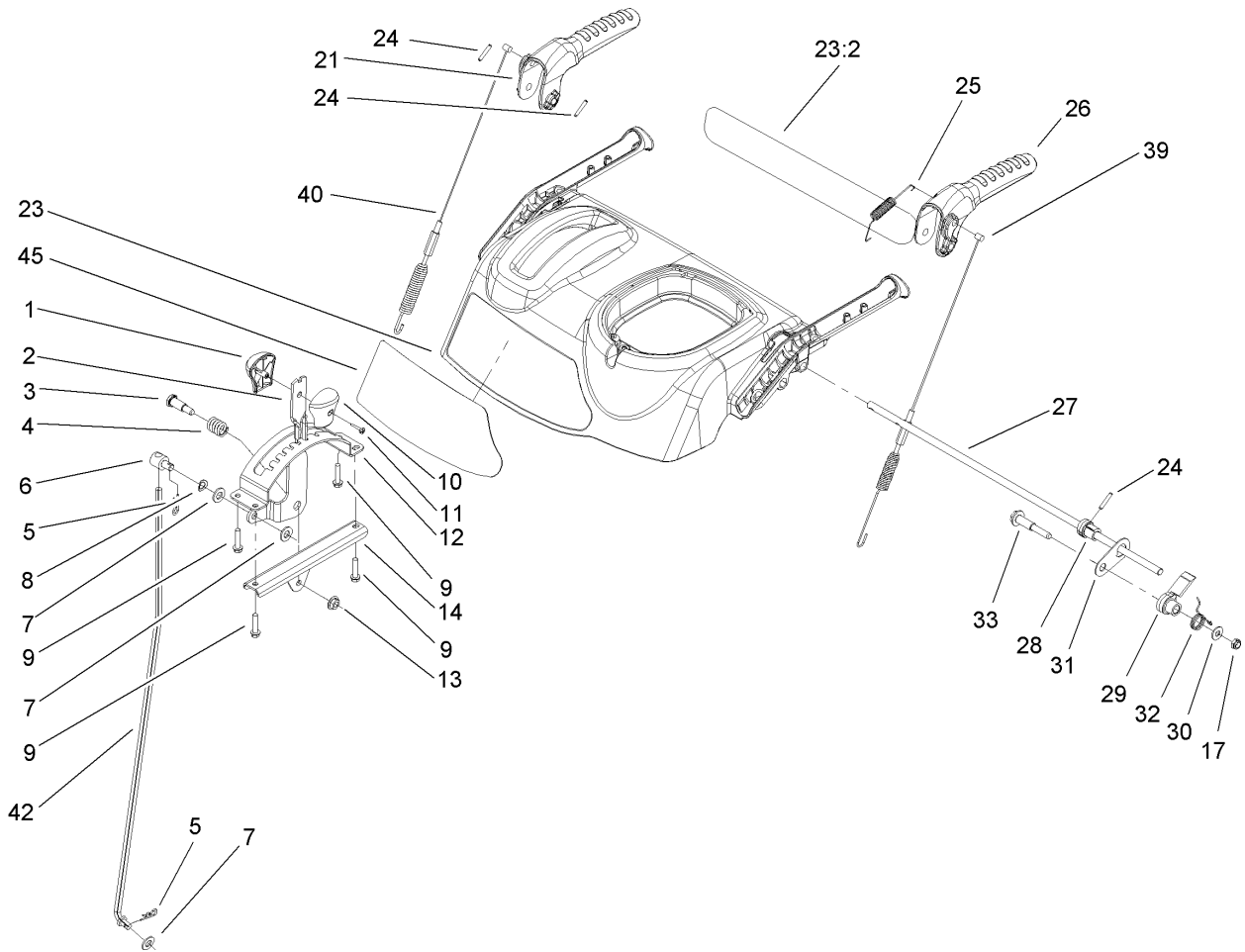

## Control Panel Assembly

Ref	Part No.	Qty.	Description
1	106-4423	1	Knob-Shift, RH
2	106-7278-03	1	Selector-Speed
3	63-2650	1	Screw-Shoulder
4	108-7313	1	Spring-Compression
5	3290-307	2	Pin-Hair
6	101161	1	Trunnion
7	3256-24	3	Washer-Flat
8	612586	1	Washer-Spring
9	46-8092	4	Screw-Plastite
10	105-9999	1	Knob-Shift, LH
11	94-4496	1	Screw-PPH
12	106-7277-03	1	Guide-Selector, Speed
13	32128-13	1	Nut-HF
14	106-7279-03	1	Mount-Selector, Speed
17	3296-72	1	Nut-Lock, NI
21	106-4413	1	Lever-Auger
23	107-3825	1	Control Panel ASM
23:2	106-4521	1	Decal-Control Panel
24	32121-125	3	Pin-Spring
25	107-3001	1	Spring-Tension
26	106-4410	1	Lever-Traction
27	105-9996	1	Rod-Lockout
28	107-1043	1	Cam-Lockout
29	108-0023	1	Latch-Lockout

Ref	Part No.	Qty.	Description
30	98-3499	1	Washer-Flat
31	107-3000	1	Link-Lockout
32	108-0024	1	Spring-Torsion
33	106-4412	1	Screw-Shoulder
39	106-4563	1	Cable-Traction
40	106-4599	1	Cable-Auger
42	107-1005	1	Rod-Shift
45	108-5062	1	Decal

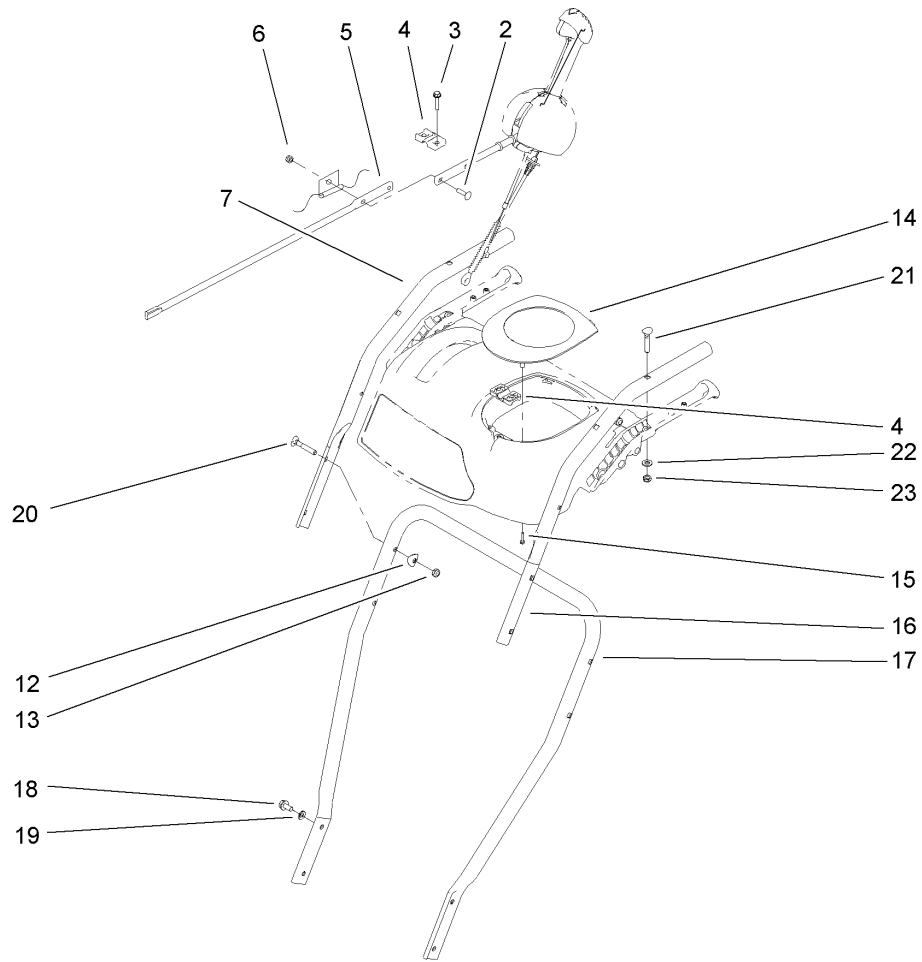

## Handle and Control Assembly

Ref	Part No.	Qty.	Description				
2	3229-30	2	Screw-CARR				
3	46-8092	2	Screw-Plastite				
4	105-9987	2	Support-Rod				
5	106-7283	1	Rod-Chute, Front				
6	3296-73	2	Nut-Lock, NI				
7	108-0038-03	1	Handle-Upper, RH				
12	107-3844	4	Washer				
13	3296-72	4	Nut-Lock, NI				
14	106-4586	1	Cover-Panel, Control				
15	94-4496	2	Screw-PPH				
16	108-0037-03	1	Handle-Upper, LH				
17	105-9981-03	1	Handle-Lower				
18	32144-14	4	Screw-HWH				
19	3290-475	4	Washer-Belleville				
20	92-2260	4	Screw-Handle				
21	107-3018	4	Screw-Handle				
22	3256-70	4	Washer-Flat				
23	3296-72	4	Nut-Lock, NI				

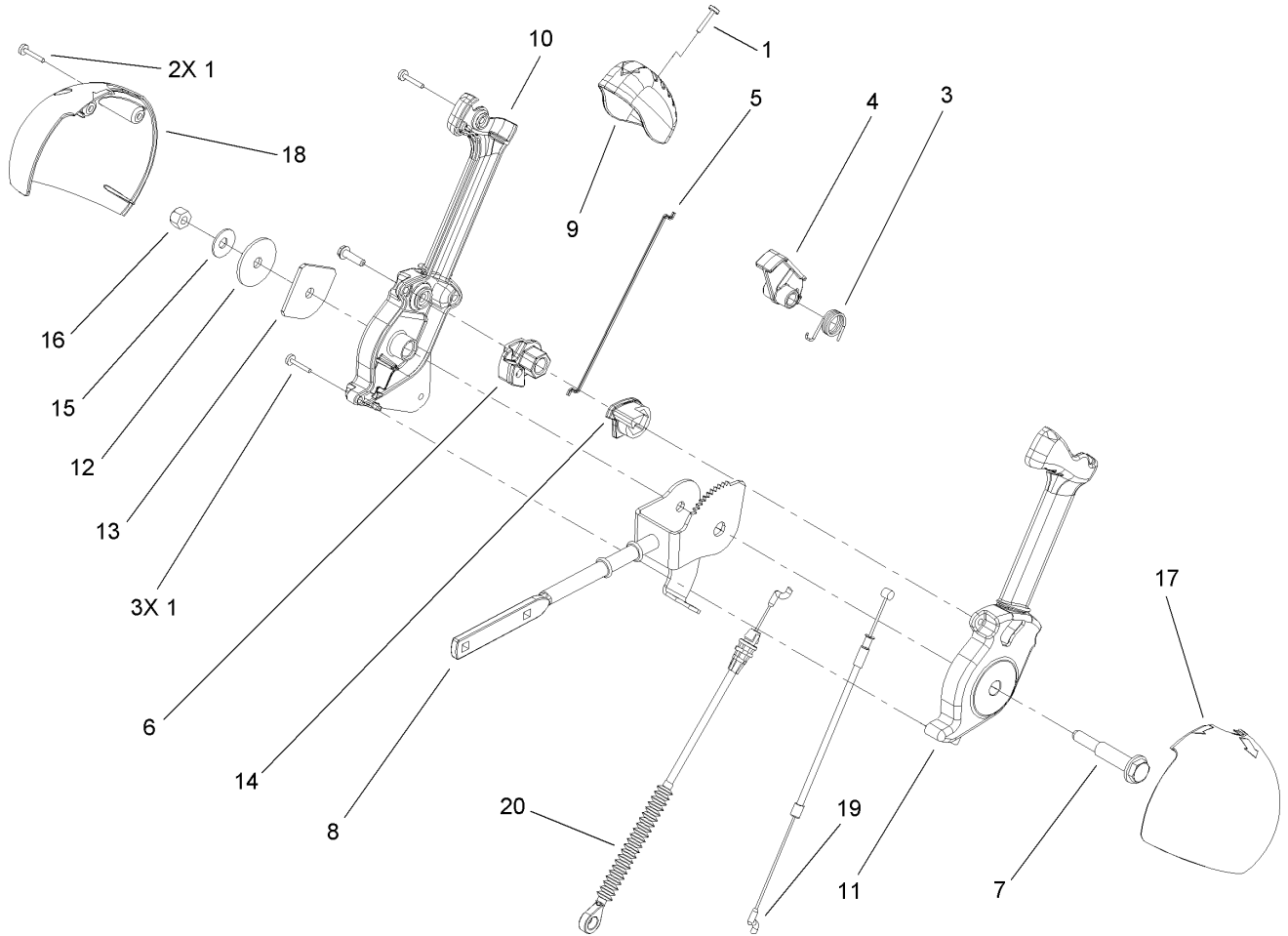

### Lever Chute Control Assembly

Ref	Part No.	Qty.	Description
1	94-4496	6	Screw-PPH
3	105-9982	1	Spring-Torsion
4	105-9984	1	Trigger-Latch
5	105-9985	1	Link-Latch
6	105-9988	1	Lever-Cable, Deflector
7	105-9995	1	Screw-Shoulder
8	106-4479	1	Rod-Control, Chute
9	106-7280	1	Cap-Lever
10	106-7281	1	Lever-Chute Control, RH
11	106-7282	1	Lever-Chute Control, LH
12	107-3002	1	Washer-Nylon
13	106-7295	1	Plate-Friction
14	106-7310	1	Pawl-Latch
15	3290-456	1	Washer-Belleville
16	3296-29	1	Nut-Lock, NI
17	105-9986	1	Cover-Chute Lever, LH
18	106-7292	1	Cover-Chute Lever, RH
19	105-9989	1	Cable-Chute Release
20	105-9990	1	Cable-Control, Deflector

--	--	--	--

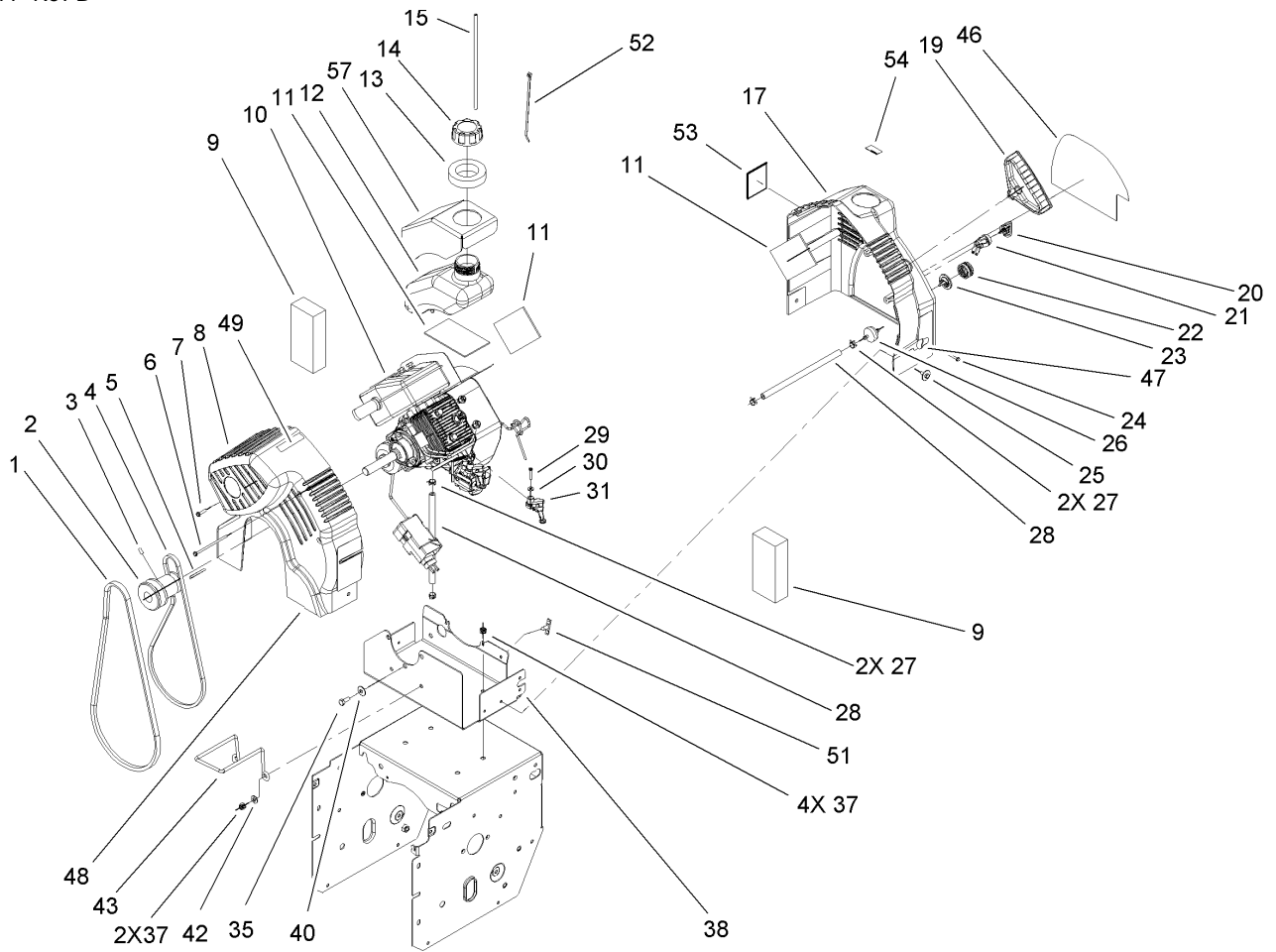

## Engine and Frame Assembly

Ref	Part No.	Qty.	Description
1	110-6254	1	Belt-V, A Section
2	105-8883	1	Pulley-Engine
3	3245-9	2	Screw-Set
4	106-9192	1	V Belt-Traction
5	7-0036	1	Key-Square
6	106-9174	2	Screw
7	106-9169	1	Screw
8	106-9194	1	Cover-Front, Styling
9	106-9178	2	Foam
10		1	Engine-Briggs And Stratton, 084333-0197-E1
11	98-1386	3	Pad-Foam
12	106-9199	1	Tank-Fuel
13	55-9310	1	Seal-Foam
14	104-4133	1	Gas Cap ASM
15	44-3170	1	Hose-Primer
17	106-9152	1	Cover ASM
19	106-9175	1	Handle-Rope Start
20	63-8360	1	Key-Ignition
21	40-5940	1	Switch
22	66-7460	1	Bulb-Primer
23	44-2750	1	Body-Primer
24	32144-27	2	Screw
25	106-9173	4	Screw

Ref	Part No.	Qty.	Description
26	56-6360	1	Filter-Fuel
27	2412-98	4	Clamp
28	49-2482	2	Line-Fuel
29	32144-97	1	Screw-PPH, Plastite
30	3256-14	1	Washer-Flat
31	104-0878	1	Lever-Choke
35	322-3	3	Screw-HH
37	3296-29	6	Nut-Lock, NI
38	105-8897-03	1	Plate-Mounting, Engine
40	3290-456	3	Washer-Belleville
42	3256-23	2	Washer-Flat
43	106-9184	1	Guide-Belt
46	106-9158	1	Decal-Panel
47	106-9160	1	Decal-Starter, Electric
48	106-9159	1	Decal-Choke
49	104-2767	1	Decal-Warning
51	32180-012	1	Clip-Harness
52	614249	3	Strap-Tie
53	110-2184	1	Decal
54	93-6659	1	Decal-Fuel, 2 Cycle
57	107-4579	1	Foam-Tank, Fuel
99	106-4741	1	Cord-Electric

1036 EMISSIONS LABEL

48 Short Block

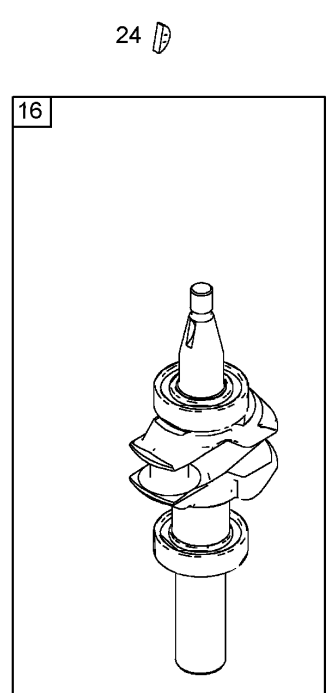
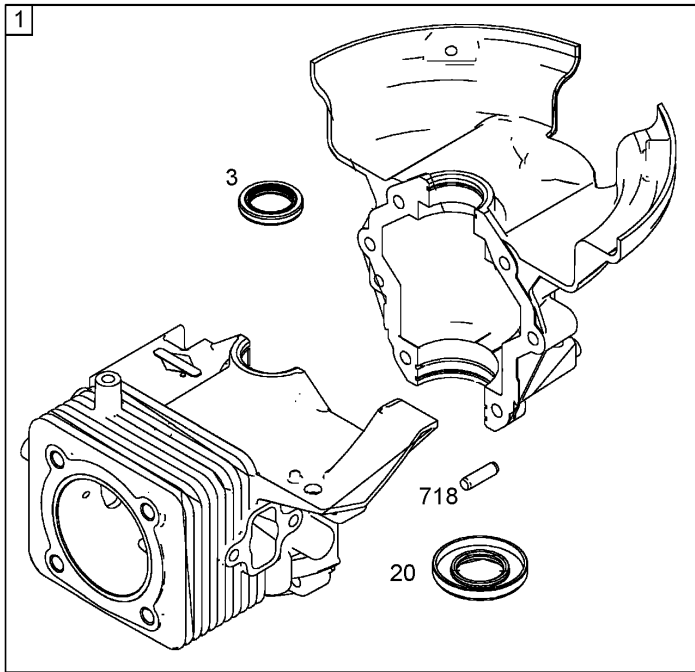
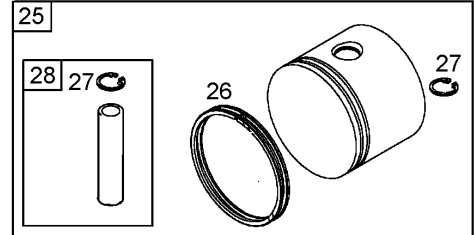
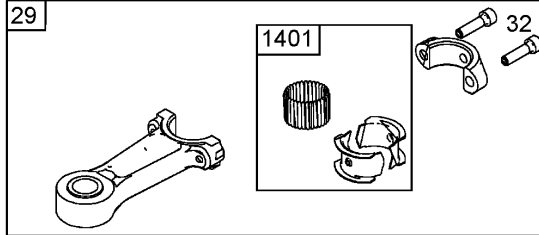
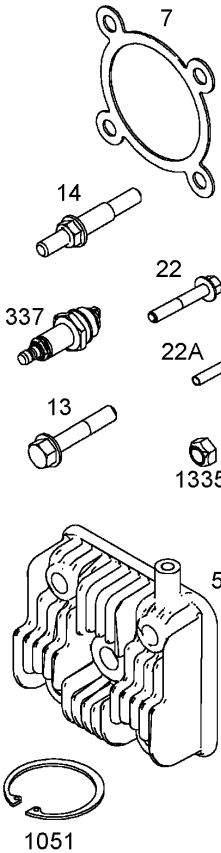

## Crankcase, Crankshaft, Cylinder Head, and Connecting Rod Assemblies Briggs and Stratton 084333-0197-E1

Ref	Part No.	Qty.	Description
1	801321	1	Cylinder ASM
3	801262	1	Seal-Oil
5	801283	1	Head-Cylinder
7	801263	1	Gasket-Head, Cylinder
13	801264	1	Screw (Cylinder Head)
14	801265	1	Stud (Cylinder Head)
16	801222	1	Crankshaft
20	801261	1	Seal-Oil
22	801266	1	Screw (Crankcase Cover And Sump)
22A	801271	1	Screw (Crankcase Cover And Sump)
24	801234	1	Key-Flywheel
25	801281	1	Piston ASM
26	801282	1	Ring Set
27	801275	1	Lock-Pin, Piston
28	801276	1	Pin-Piston
29	801277	1	Rod-Connecting
32	801278	1	Screw
48	801288	1	Short Block
337	801254	1	Plug-Spark
718	690959	1	Pin-Locating
1036	801295	1	Label-Emissions
1051	801274	1	Ring-Retaining

Ref	Part No.	Qty.	Description
1335	801269	1	Nut (Blower Housing)
1401	801290	1	Roller-Strip

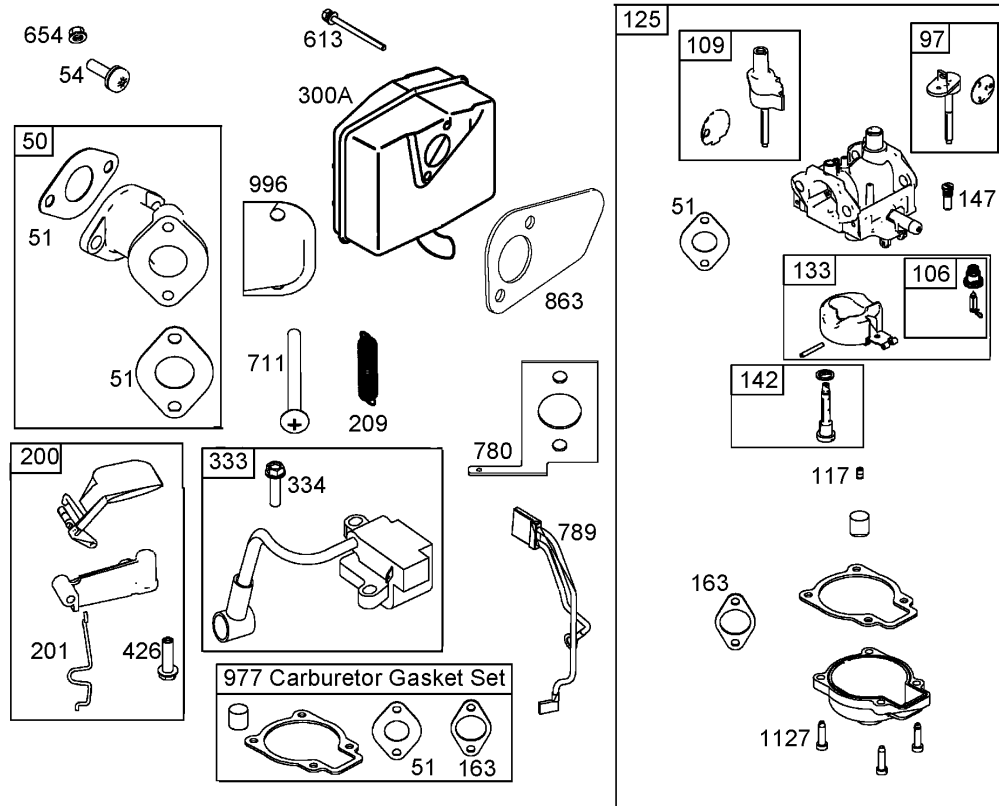

## Intake Manifold, Carburetor, and Muffler Assemblies Briggs and Stratton 084333-0197-E1

Ref	Part No.	Qty.	Description
50	801232	1	Manifold-Intake
51	801224	1	Gasket-Intake
54	801230	1	Screw (Intake Manifold)
97	801306	1	Shaft-Throttle
106	801317	1	Seat-Inlet
109	801307	1	Shaft-Choke
117	801311	1	Jet-Main
125	801255	1	Carburetor
133	801316	1	Float-Carburetor
142	801313	1	Nozzle-Carburetor
147	801309	1	Jet-Pilot
163	801227	1	Gasket-Cleaner, Air
200	801289	1	Blade-Governor
201	801225	1	Link-Vane, Air
209	801223	1	Spring-Governor
300A	801258	1	Muffler
333	801268	1	Armature-Magneto
334	801267	1	Screw
426	801231	1	Screw
613	801251	1	Screw
654	801324	1	Nut (Intake Manifold) (Used Before Engine Code Date 05042600)
711	801229	1	Screw

Ref	Part No.	Qty.	Description
780	801228	1	Anchor-Spring
789	801253	1	Wire ASM
863	801259	1	Bracket-Muffler
977	801312	1	Gasket Set-Carburetor
996	801226	1	Shield-Carburetor
1127	801318	1	Screw

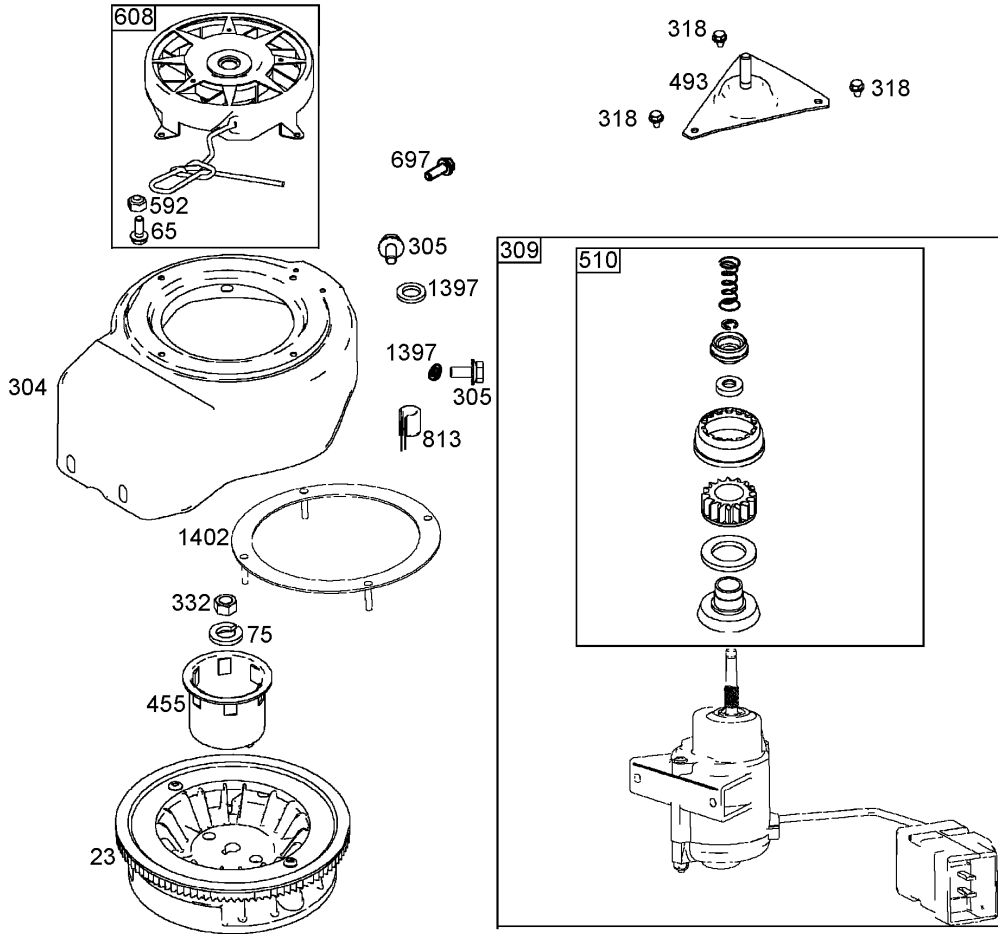

## Flywheel, Blower Housing, and Starter Assemblies Briggs and Stratton 084333-0197-E1

Ref	Part No.	Qty.	Description
❶23	801246	1	Flywheel
❶65	801243	1	Screw
❶75	801237	1	Washer
❶304	801315	1	Housing-Blower
❶305	801239	1	Screw (Blower Housing)
❶309	801247	1	Motor-Starter
❶318	801241	1	Screw
❶332	801238	1	Nut
❶455	801235	1	Cup-Flywheel
❶493	801240	1	Bracket-Mounting
❶510	801293	1	Drive-Starter
❶592	801244	1	Nut
❶608	801242	1	Starter-Rewind
❶697	801248	1	Screw (Starter Motor)
❶813	801249	1	Clamp
❶1397	801270	1	Washer (Blower Housing)
❶1402	801272	1	Ring-Support

# Attachments and Accessories

## For 38610 - Power Max 6000 Snowthrower

<b>Product Name</b>	<b>Model/Part</b>
Tire Chain Kit .....	107-3813
Snow Cab .....	107-3814
Weight Kit .....	107-3815
26 Inch Drift Breaker .....	107-3816

# NOTES

# NOTES

# NOTES

