



53cm Heavy-Duty Recycler[®] Rear Bagging Lawnmower

Model No. 22177TE - 260001051 and up.

Parts Catalog

Ordering Replacement Parts

To order replacement parts, please supply the part number, the quantity, and the description of each part desired.

Understanding Reference Numbers

Each Identified part in an illustration has a reference number. The reference number for a part also appears in the parts list, along with other information about the part.

This catalog uses two special reference number formats, one to indicate parts in a service assembly and another to indicate the quantity of a given part in an illustration.

Service Assembly Reference Numbers

Parts in service assemblies have reference numbers in the form a:b. The a represents the reference number of the entire service assembly and the b represents a sequential number unique to each part within the service assembly.

For example, a wheel assembly might be identified by reference number 6, the tire by 6:1, the valve by 6:2, and the wheel by 6:3. When you order the assembly identified by reference number 6, you receive all parts identified by reference numbers 6:1, 6:2, and 6:3. However, you may also order any part individually. Reference numbers of this type appear in illustrations and in part lists.

Reference Numbers Indicating Quantity

In an illustration, if a reference number indicates more than one part, the reference number has the form nX y. The n represents the quantity of the part, the X is the multiplication symbol, and the y represents the reference number.

For example, in an illustration, the reference number 2X 37 means that two of the parts identified by reference number 37 are indicated.

Contents

Description	Page	Description	Page
Housing, Chute and Wheel Assembly 3	Grass Bag Assembly No. 106-0975 13
Housing Assembly No. 98-7146 4	Cylinder and Crankcase Assembly 14
Front Wheel and Tire Assembly No. 100-2870 5	Piston and Crankshaft Assembly 15
Gear Case Assembly No. 74-1861 6	Valve and Camshaft Assembly 16
Engine and Blade Assembly 7	Lubrication Equipment Assembly 17
Fuel Tank Assembly 8	Cooling Equipment Assembly 18
Handle Assembly 9	Electrical Equipment Assembly 19
Control Panel Assembly 10	Control Equipment Assembly 20
Rear Drive and Wheel Assembly 11	Carburetor Assembly 21
Rear Wheel Assembly No. 100-2860 12	Air Filter and Muffler Assembly 22
		Starter Assembly 23

Part Description Abbreviations

Part descriptions in this catalog may include the following abbreviations.

AR. as required	INC. incorporated
ASM. assembly	LH. left hand
BBC. blade brake clutch	NI. nylon insert
CARR. carriage	NPTF. national pipe thread fine
DEG. degrees	PFH. phillips flat head
EXT. external	PPH. phillips pan head
FH. flat head	PPHTF. phillips pan head thread forming
GA. gauge	PRH. phillips round head
HF. hex flange	PTH. phillips truss head
HH. hex head	PTO. power-take-off
HHF. hex head flange	RH. right hand
HHFTF. hex head flange thread forming	ROPS. roll-over-protection-system
HJ. hex jam	SFH. slotted fillister head
HLH. hex lag head	SHH. slotted hex head
HOC. height-of-cut	SHWH. slotted hex washer head
HSBH. hex socket button head	SPH. slotted pan head
HSFH. hex socket flat head	SQH. square head
HSH. hex socket head	SRH. slotted round head
HWH. hex washer head	STD. standard
HWHTF. hex washer head thread forming	TAP. self tapping
HYD. hydraulic	TTH. torx truss head

Footnotes

❶ Not illustrated

❷ Not serviced separately

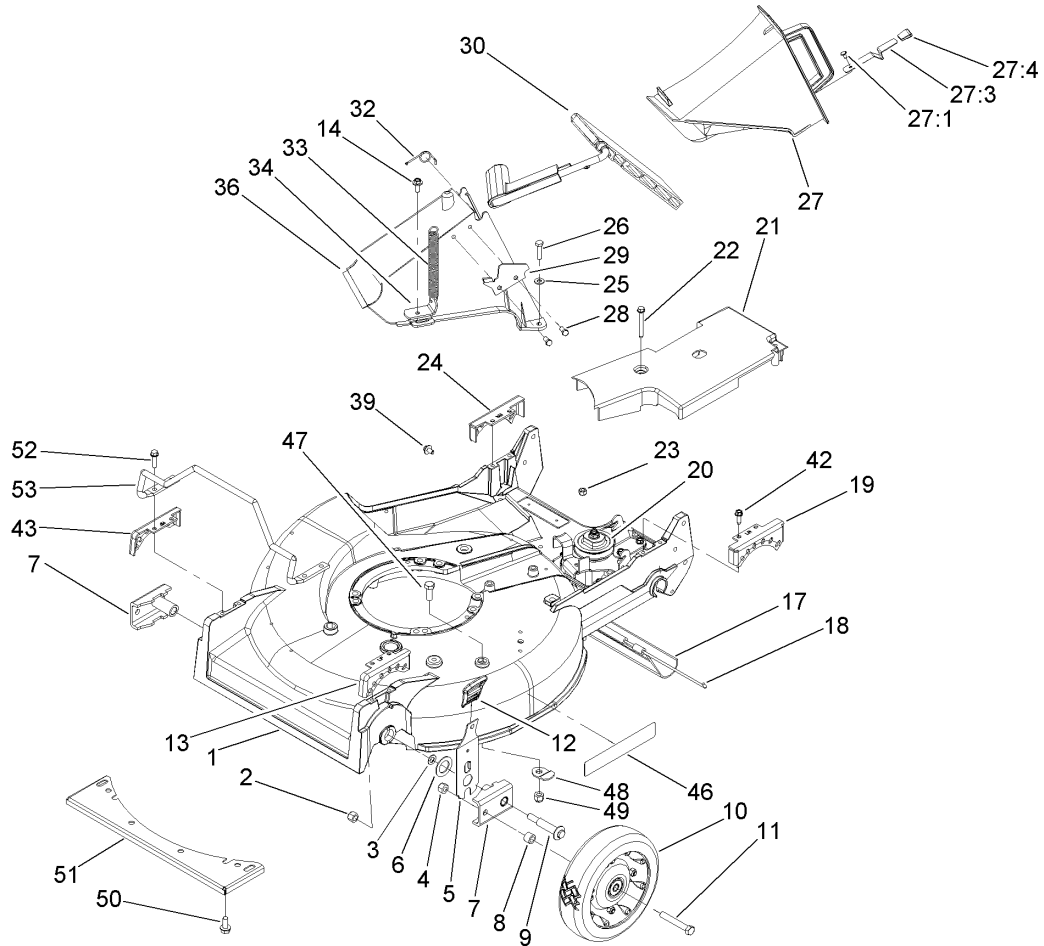

Housing, Chute and Wheel Assembly

Ref	Part No.	Qty.	Description
1	98-7146	1	Housing
2	3296-6	2	Nut-Lock
3	40-1940	2	Washer
4	32152-2	2	Nut-Lock, Cone
5	110-0537	2	Spring Arm ASM
6	257-3	2	Washer-Thrust
7	61-8300	2	Arm-Pivot, Front
8	52-2480	2	Spacer-Wheel
9	27-6232	2	Bolt-Wheel
10	100-2870	1	Wheel And Tire ASM
11	323-12	2	Screw-HH
12	110-0549	2	Knob-HOC
13	49-8760	1	Quadrant-Front, LH
14	46-6811	1	Screw-HWH
17	44-0580	1	Shield-Trailing
18	33-3208	1	Rod-Shield
19	49-8740	1	Quadrant-Rear, LH
20	74-1861	1	Gear Case ASM
21	74-1770	1	Cover-Belt
22	37-7260	2	Screw-HH
23	3296-42	2	Nut-Lock, NI
24	49-8750	1	Quadrant-Rear, RH
25	3256-22	2	Washer-Flat
26	321-8	2	Screw-HH

Ref	Part No.	Qty.	Description
27	77-0502	1	Discharge Plug ASM
27:1	3295-35	1	Rivet-Head, Flat
27:3	76-4640	1	Latch-Plug, Discharge
27:4	76-4650	1	Grip-Latch
28	46-8090	2	Screw-Plastite
29	93-3154	1	Latch-Plate
30	93-7351	1	Discharge Door ASM
32	80-3770	1	Retainer-Door
33	76-4660	1	Spring-Door
34	71-9350	1	Bracket-Spring
36	82-9151	1	Tunnel-Discharge
39	46-6810	1	Screw And Washer ASM
42	49-2040	4	Screw-HWHTF
43	49-8770	1	Quadrant-Front, RH
46	106-0689	1	Decal
47	323-6	3	Screw-HH
48	84-8930	3	Shield-Retainer
49	3296-39	3	Nut-Lock, NI
50	32144-70	4	Screw-HH
51	46-5400-03	1	Shield
52	32144-86	4	Screw-HWHTF
53	99-6722	1	Guard-Engine

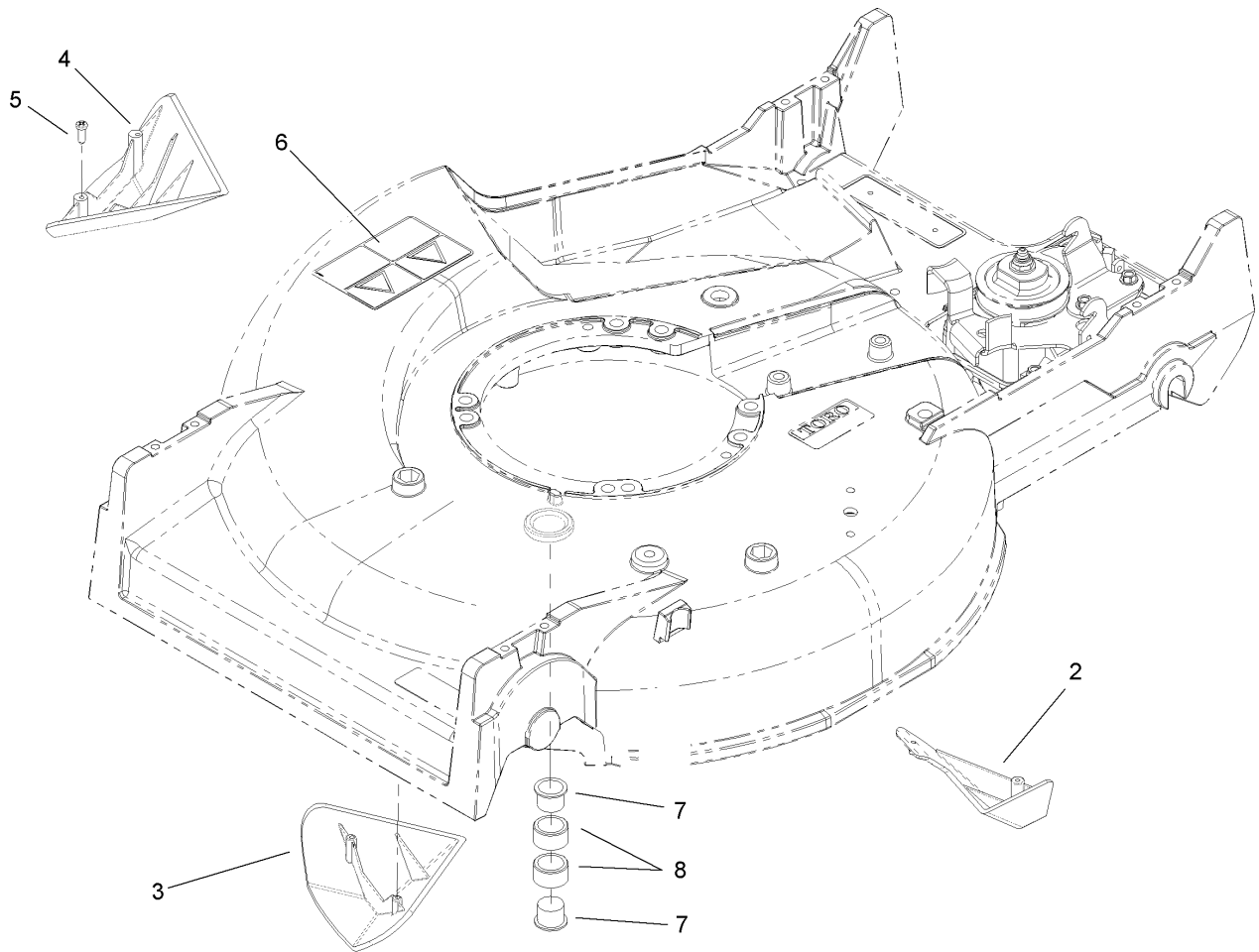

Housing Assembly No. 98-7146

Ref	Part No.	Qty.	Description				
2	92-1750	1	Kicker-Rear				
3	92-1720	1	Kicker-Front				
4	92-1730	1	Kicker-RH				
5	32144-111	6	Screw-PPH				
6	93-6654	1	Decal-Danger				
7	2410-72	2	Caplug				
8	68-9780	2	Bearing				

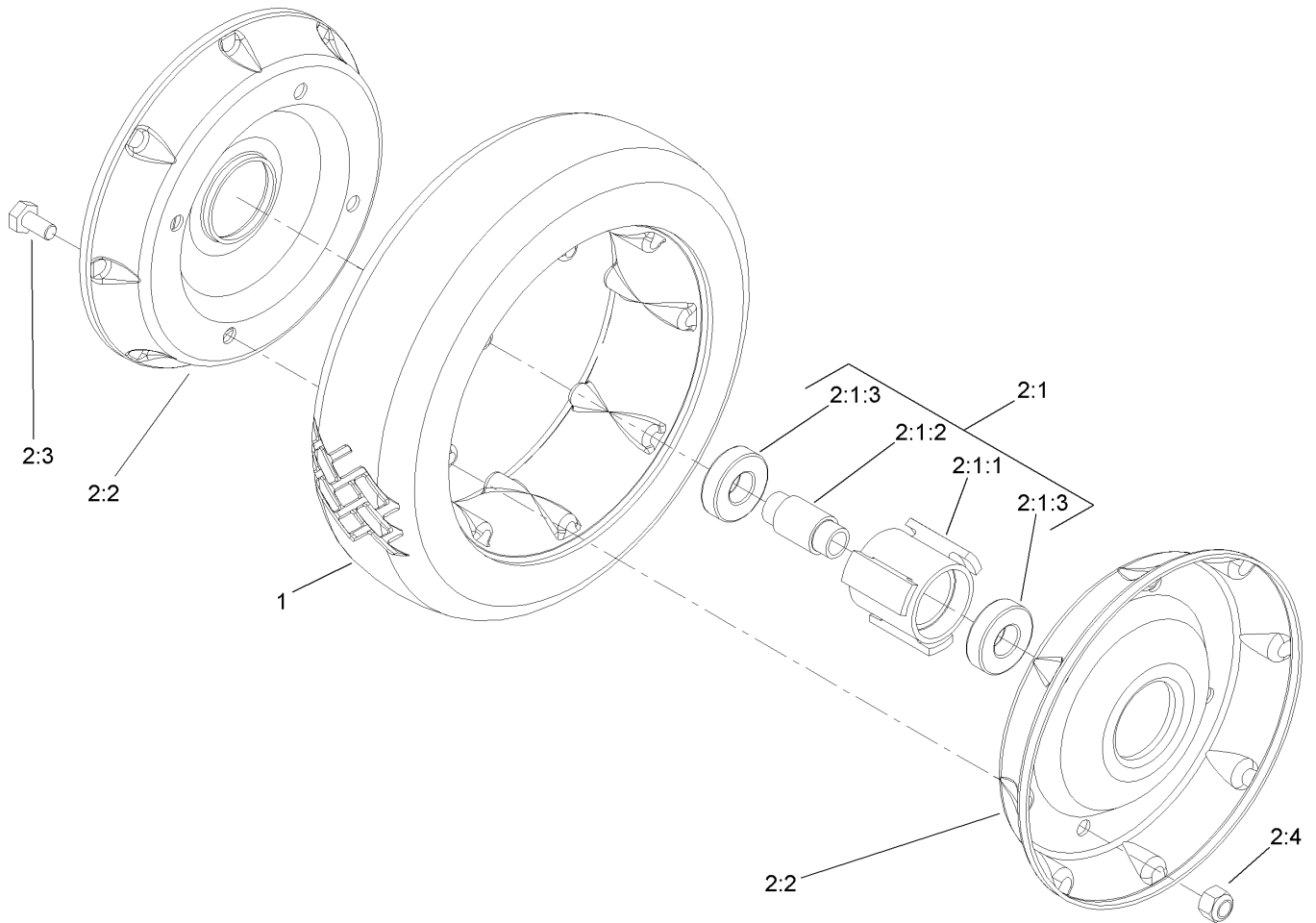

Front Wheel and Tire Assembly No. 100-2870

Ref	Part No.	Qty.	Description
1	53-7740	1	Tire
2		1	Wheel ASM
2:1		1	Hub And Bearing ASM
2:1:1	52-2410	1	Hub-Bearing
2:1:2	52-2440	1	Spacer-Bearing
2:1:3	52-2450	2	Bearing-Wheel
2:2	53-7780-06	2	Plate-Wheel, Half
2:3	321-2	4	Screw-HH
2:4	3296-42	4	Nut-Lock, NI

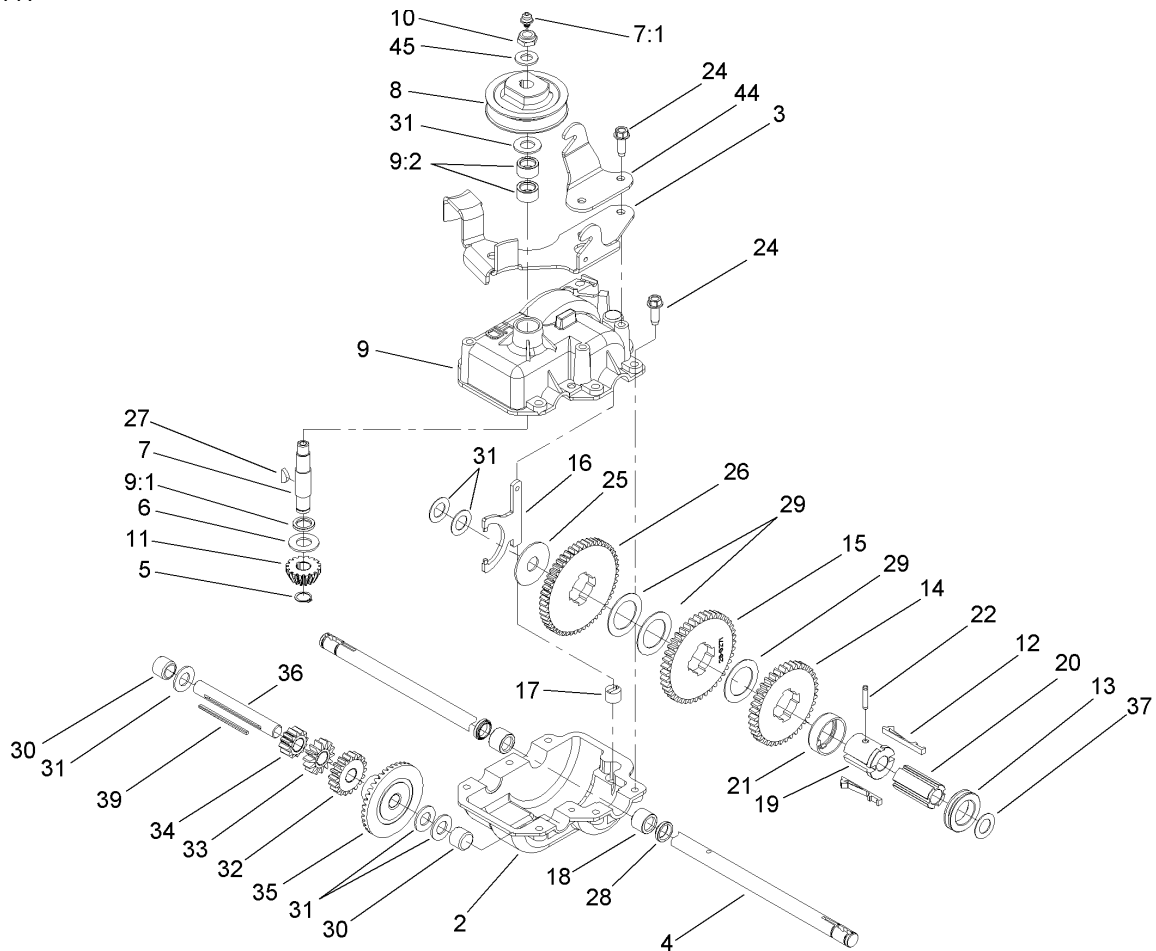

Gear Case Assembly No. 74-1861

Ref	Part No.	Qty.	Description
2	74-1920	1	Case-Gear, Lower
3	49-8461-03	1	Bracket-Guide, Belt
4	74-1890	1	Shaft-Output
5	32151-57	1	Ring-Retaining
6	47-2910	1	Washer-Thrust
7	13-5149	1	Input Shaft ASM
7:1	302-63	1	Zerk
8	39-6740	1	Pulley
9	13-9739	1	Upper Gearcase ASM
9:1	47-7260	1	Seal
9:2	47-7270	2	Bearing
10	3296-5	1	Nut-Lock
11	39-6660	1	Pinion-Bevel
12	29-9330	2	Key-Shift
13	29-9340	1	Collar-Shift
14	42-4740	1	Gear-38T
15	29-9271	1	Gear-42T
16	60-8870	1	Yoke-Shift
17	29-9570	1	Bushing-Yoke
18	47-6730	2	Seal-Oil
19	55-8010	1	Sleeve-Gear
20	39-6720	1	Sleeve
21	55-8020	1	Retainer-Key
22	3285-19	1	Pin-Groove

Ref	Part No.	Qty.	Description
24	49-2040	6	Screw-HWHTF
25	29-9690	1	Washer
26	46-3560	1	Gear
27	3257-1	2	Key-Woodruff
28	48-2060	2	Bearing-Roller
29	36-4770	3	Washer
30	252-103	2	Bearing-Closed
31	36-4792	4	Washer-Thrust
32	39-6650	1	Gear-18T
33	46-3550	1	Gear-14T
34	46-3540	1	Gear-12T
35	74-1760	1	Gear-Bevel
36	53-7950	1	Shaft-Intermediate
37	36-4780	3	Washer
39	39-7842	1	Key
44	74-1750-03	1	Bracket-Engage, Traction
45	3256-45	1	Washer-Flat

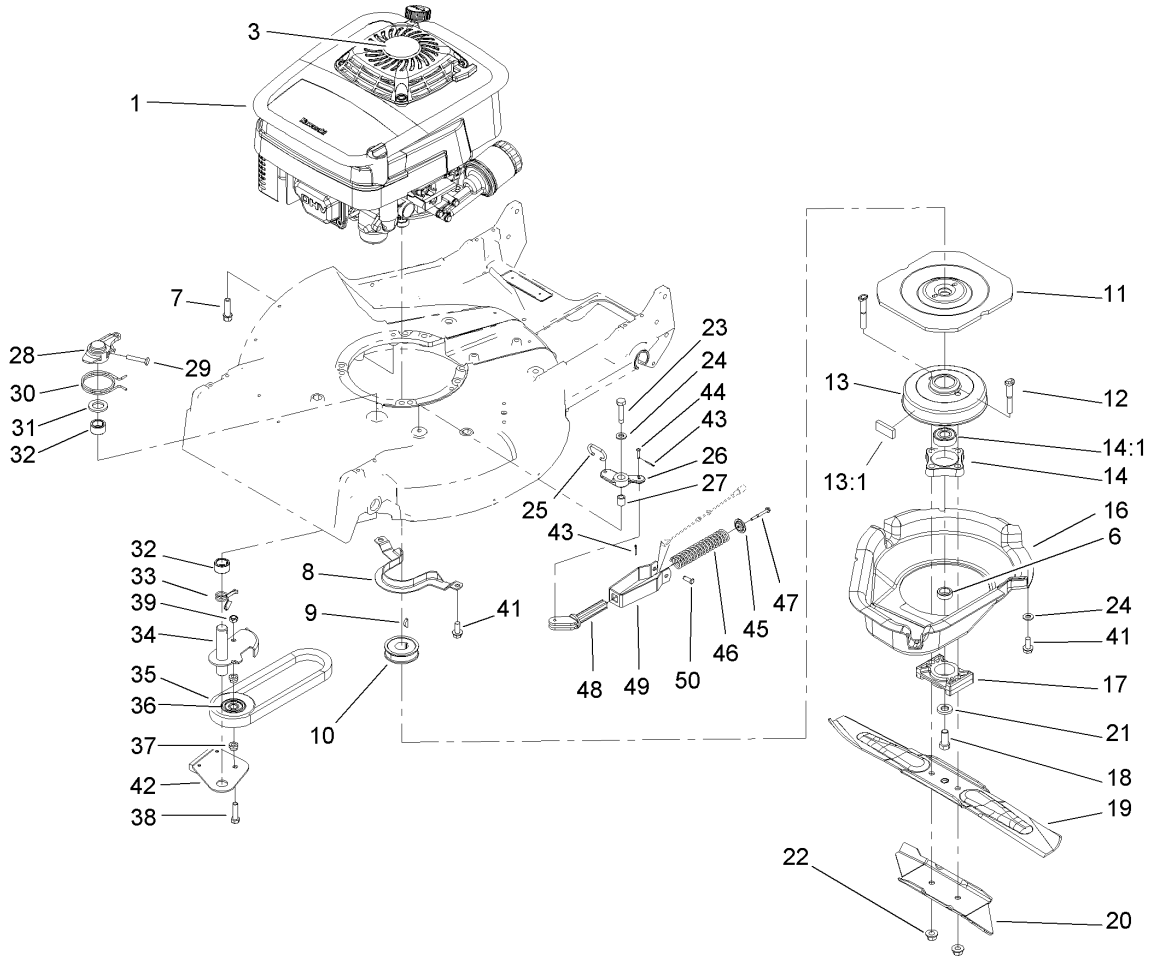

Engine and Blade Assembly

Ref	Part No.	Qty.	Description
1		1	Engine ASM
3	110-0520	1	Decal
6	107-4058	1	Spacer-Output Shaft
7	95-1727	4	Screw-Taptite
8	66-0570-03	1	Bracket-Guide, Belt
9	3257-17	1	Key-Woodruff
10	56-6180	1	Pulley-Driver
11	56-6160-03	1	Flywheel-BBC
12	42-3190	2	Bolt-Blade
13	94-9431	1	Brake Drum ASM
13:1	52-3480	2	Dampener-Vibration
14	42-6890	1	Hub ASM
14:1	100-1048	2	Bearing-Ball
16	46-5693	1	Shield
17	107-4275	1	Spacer-Blade
18	3212-4	1	Screw-HH
19	91-2256-03	1	Blade-21 Inch
20	91-2255-03	1	Stiffener-Blade
21	1-603610	2	Washer-Spring
22	54-9190	2	Nut-Lock
23	32104-107	1	Screw-HH
24	3256-23	2	Washer-Flat
25	49-2810	1	Link-Control
26	49-7960	1	Bellcrank

Ref	Part No.	Qty.	Description
27	49-7950	1	Sleeve-Bellcrank
28	49-2820	1	Lever
29	32104-96	1	Screw-HH
30	49-7970	1	Spring-Torsion
31	70-1160	1	Washer
32	68-9780	2	Bearing
33	85-6880	1	Spring-Torsion
34	84-9130	1	Arm-Idler
35	42-0884	1	V-Belt
36	46-5650	1	Pulley-Idler
37	46-5631	2	Hub-Pulley, Idler
38	322-6	1	Screw-HH
39	3296-47	1	Nut-Lock, NI
41	32144-70	3	Screw-HH
42	84-9180	1	Brake Plate ASM
43	3272-1	2	Pin-Cotter
44	84-9050	1	Pin-Spring
45	65-5280	1	Retainer-Spring
46	84-9100	1	Spring
47	46-7040	1	Screw-HWHTF
48	106-0842	1	Guide-Spring
49	107-4087-03	1	Bracket-Spring
50	84-9040	1	Pin-Cable

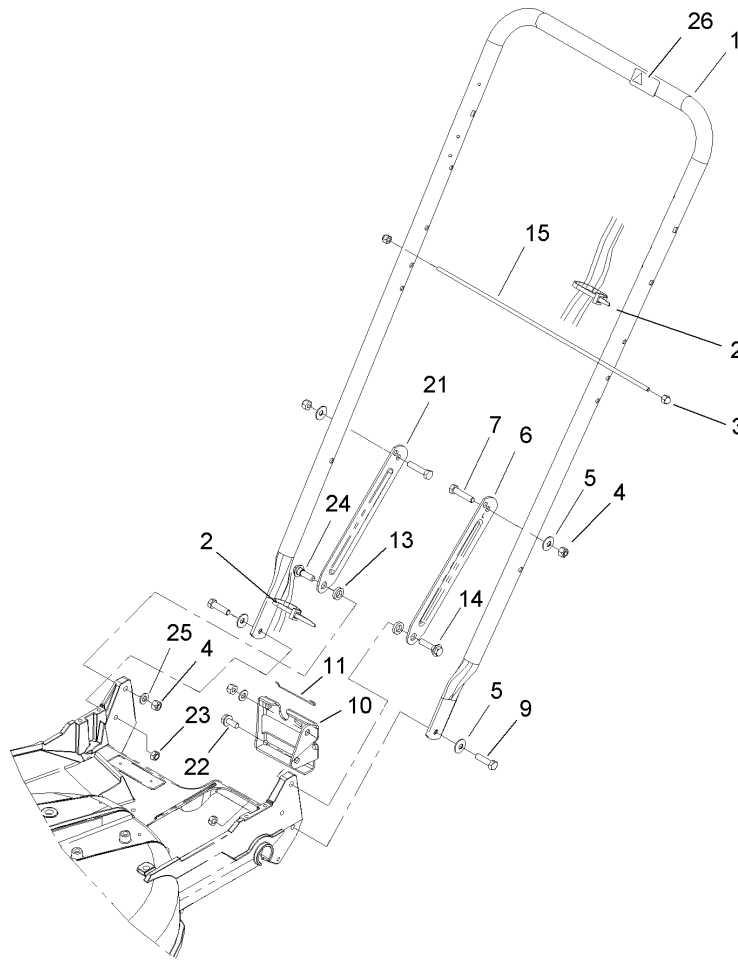

Handle Assembly

Ref	Part No.	Qty.	Description
1	98-2385-03	1	Handle
2	3290-378	2	Tie-Cable
3	32111-7	2	Nut-Cap
4	3296-29	4	Nut-Lock, NI
5	3290-456	4	Washer-Belleville
6	100-3298-03	1	Latch-Handle, LH
7	322-7	2	Screw-HH
9	322-6	2	Screw-HH
10	74-1741	1	Bracket-Adjustment, Traction
11	46-7030	1	Retainer-Cable
13	3-3287	2	Spacer-Latch, Handle
14	27-7210	1	Screw-Shoulder
15	48-2810	1	Rod-Support, Bag
21	100-3297-03	1	Latch-Handle, RH
22	32144-70	1	Screw-HH
23	3296-47	2	Nut-Lock, NI
24	27-7211	1	Screw-Shoulder
25	3256-23	2	Washer-Flat
26	98-4387	1	Decal-Protection, Ear

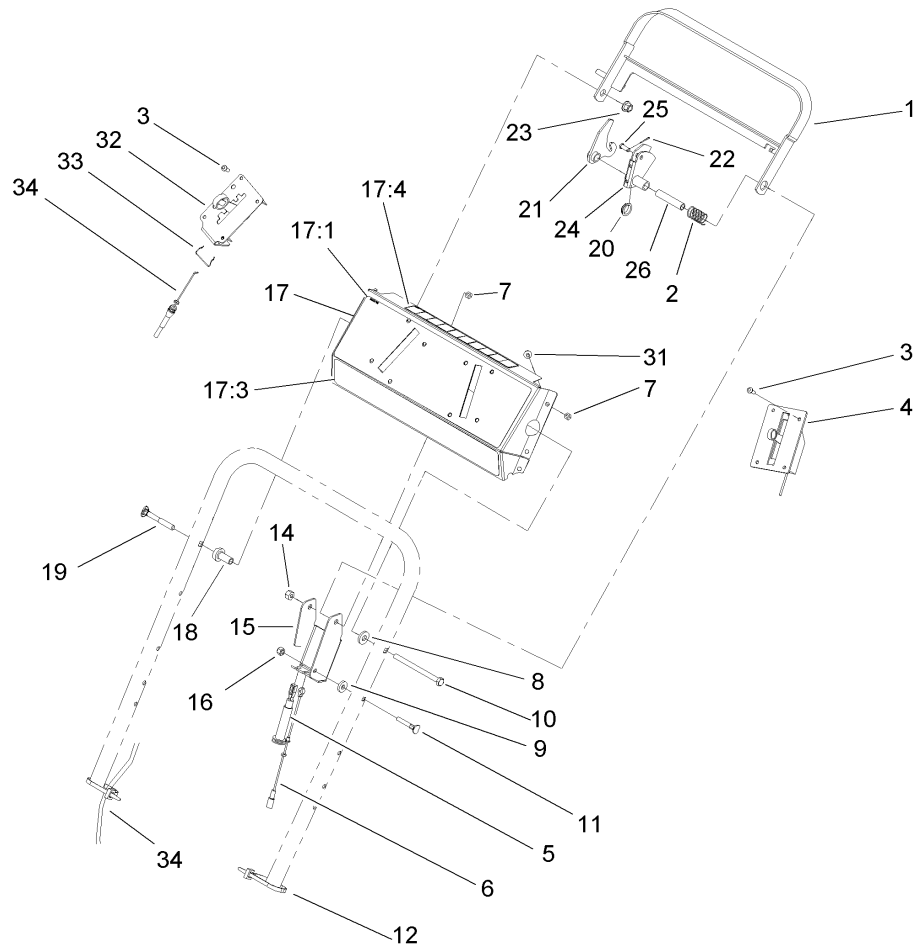

Control Panel Assembly

Ref	Part No.	Qty.	Description
1	84-8940-03	1	Bar-Control
2	85-6750	1	Spring-Control
3	3250-12	8	Screw-PPH
4	106-0857	1	Control-Throttle
5	84-9120	1	Cable-Traction
6	84-9110	1	Cable-Clutch
7	3296-2	8	Nut-Lock
8	71-9310	1	Spacer
9	71-9320	1	Spacer
10	322-19	1	Screw-HH
11	46-6430	1	Screw-Handle
12	3290-378	2	Tie-Cable
14	3296-29	1	Nut-Lock, NI
15	92-1778-03	1	Bracket-Control
16	3296-42	1	Nut-Lock, NI
17	99-8137	1	Panel ASM
17:1	98-2006	1	Decal-Panel, Control
17:3	106-0771	1	Decal-Panel
17:4	93-6655	1	Decal-Panel, Rear
18	49-1631	1	Spacer-Support
19	17-9427	1	Screw
20	86-9320	1	Bushing-Flange
21	84-9000	1	Lever-Traction
22	3272-1	1	Pin-Cotter

Ref	Part No.	Qty.	Description
23	3296-58	1	Nut-Lock, NI
24	84-8990	1	Lever-BBC
25	84-9040	1	Pin-Cable
26	84-9030	1	Spacer-Bracket, Control
31	32104-76	6	Screw
32	99-2542	1	Control-Shift
33	85-6780	1	Retainer-Cable, Throttle
34	99-2541	1	Cable-Shift

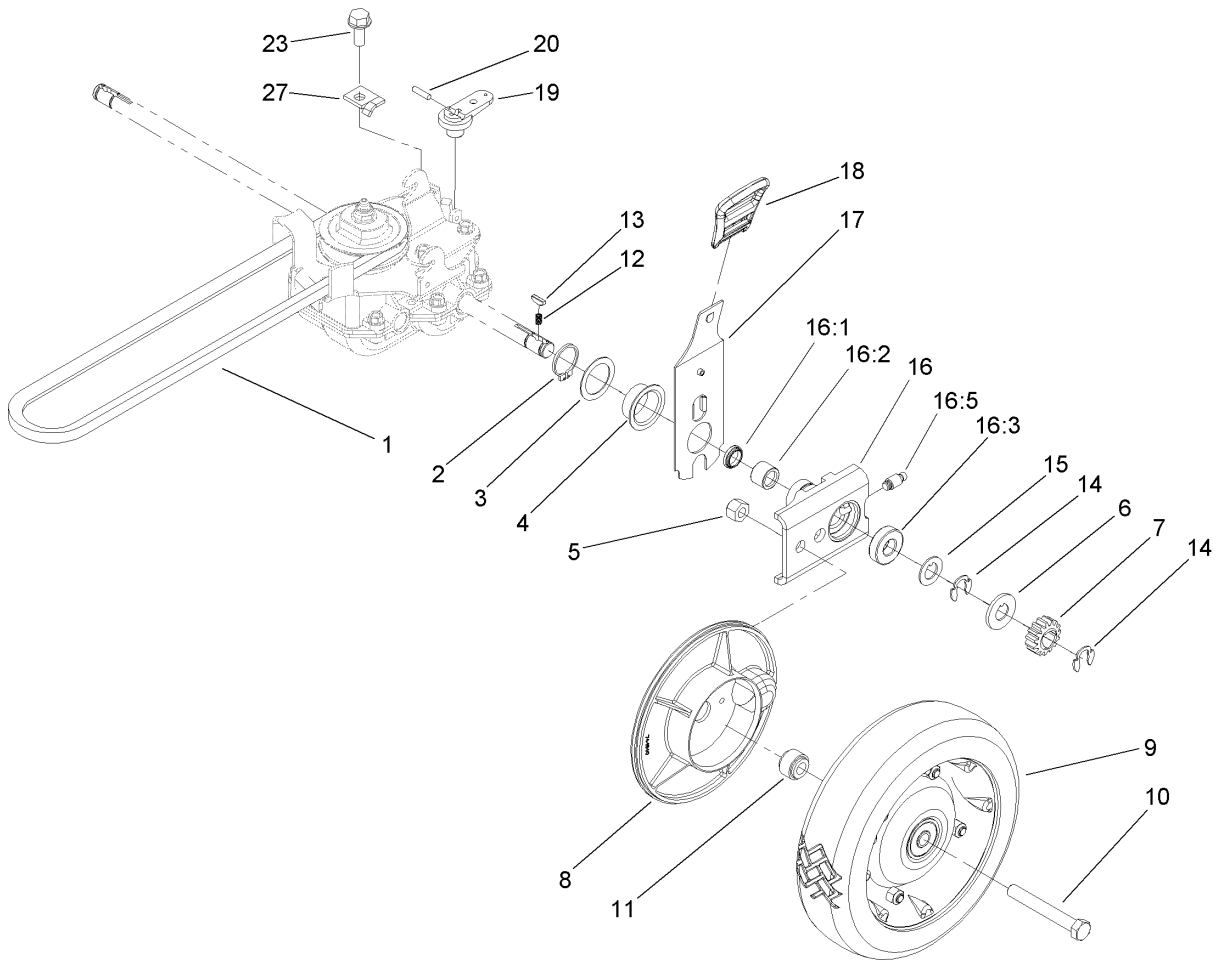

Rear Drive and Wheel Assembly

Ref	Part No.	Qty.	Description
1	36-8070	1	V-Belt
2	32151-36	2	Ring-Retaining
3	74-1810	2	Washer
4	48-2170	2	Cap-End
5	32152-2	2	Nut-Lock, Cone
6	62-3830	2	Washer-Thrust, Outer
7	39-9160	2	Gear-Pinion
8	74-1640	2	Cover-Wheel
9	100-2860	2	Wheel And Tire ASM
10	323-13	2	Screw-HH
11	74-1650	2	Spacer-Cover, Wheel
12	39-9650	2	Spring-Compression
13	612066	2	Key
14	32151-68	4	Ring-Retaining
15	49-7700	2	Washer-Thrust, Outer
16	74-1851	2	Pivot Arm ASM
16:1	47-6730	1	Seal-Oil
16:2	48-2060	1	Bearing-Roller
16:3	52-2450	1	Bearing-Wheel
16:5	92-6316	1	Zerk
17	110-0538	2	Rear Spring Arm ASM
18	110-0549	2	Knob-HOC
19	29-9560	1	Lever-Shift
20	32121-99	1	Pin-Coil

Ref	Part No.	Qty.	Description
23	32144-70	1	Screw-HH
27	62-3720	1	Clamp-Cable
●99	106-0975	1	Grass Bag ASM

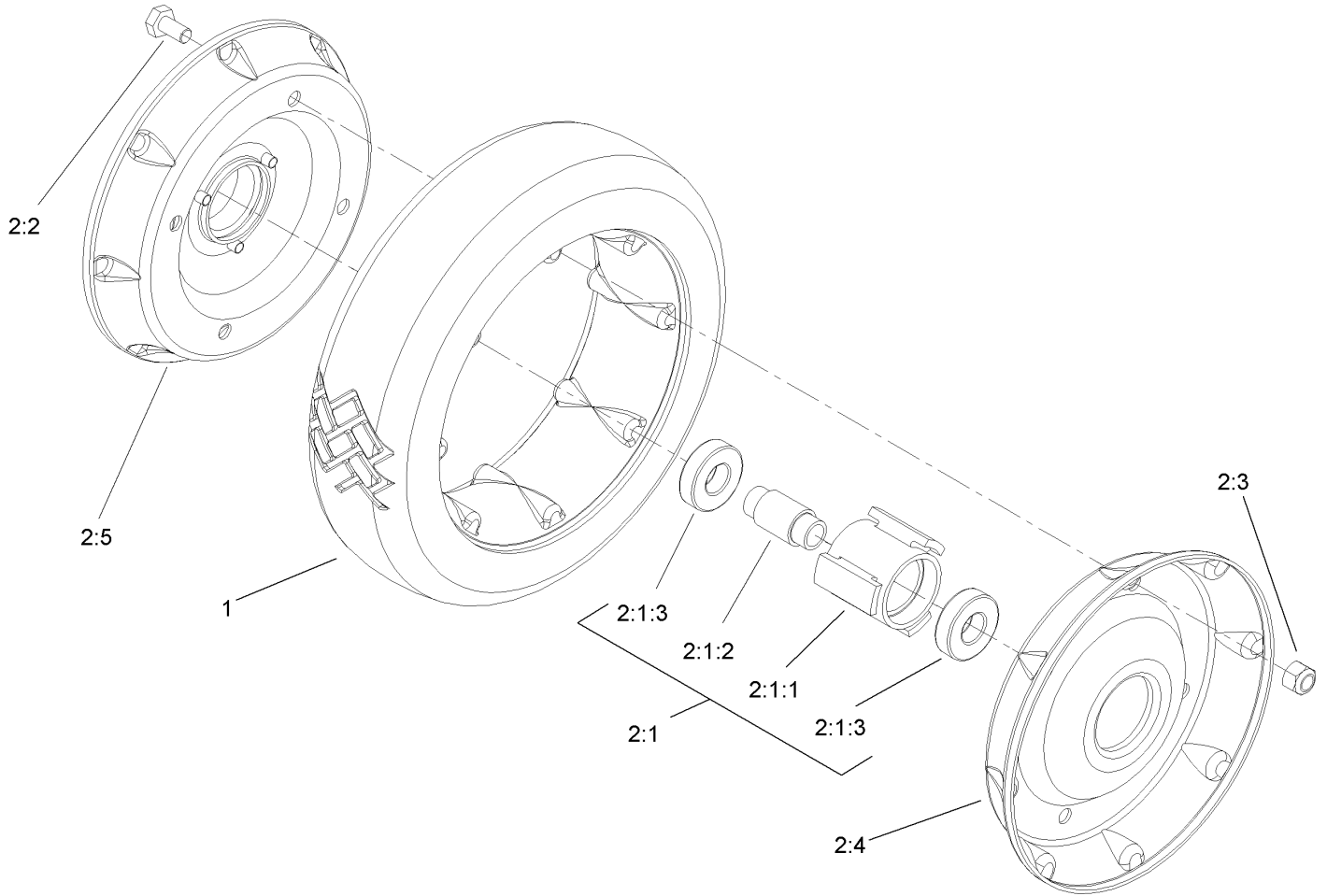

Rear Wheel Assembly No. 100-2860

Ref	Part No.	Qty.	Description
1	53-7740	1	Tire
2		1	Wheel ASM
2:1		1	Hub And Bearing ASM
2:1:1	52-2410	1	Hub-Bearing
2:1:2	52-2440	1	Spacer-Bearing
2:1:3	52-2450	2	Bearing-Wheel
2:2	321-2	4	Screw-HH
2:3	3296-42	4	Nut-Lock, NI
2:4	53-7780-06	1	Plate-Wheel, Half
2:5	92-4957-06	1	Wheel Half And Gear ASM

Ref	Part No.	Qty.	Description

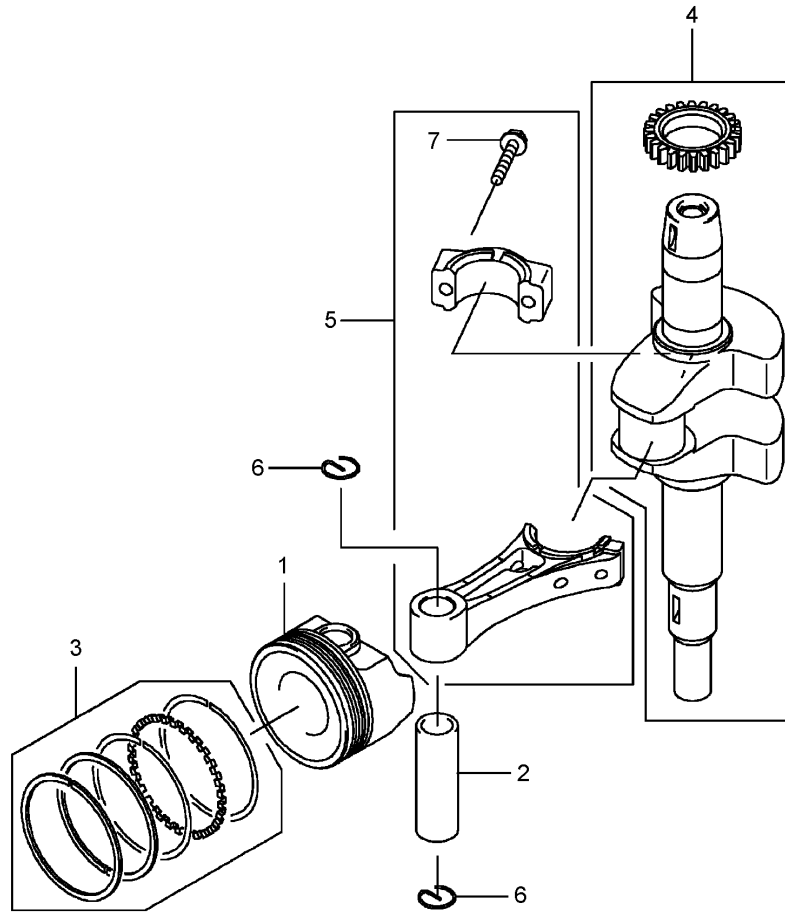

Piston and Crankshaft Assembly

Ref	Part No.	Qty.	Description
1	108-2516	1	Piston-Engine
2	108-2517	1	Pin-Piston
3	108-2518	1	Ring-Set, Piston
4	108-2626	1	Crankshaft-Comp (BBC)
5	108-2520	1	Connecting Rod ASM
6	108-2521	2	Ring-Snap
7	108-2522	2	Bolt-Flange

--	--	--	--

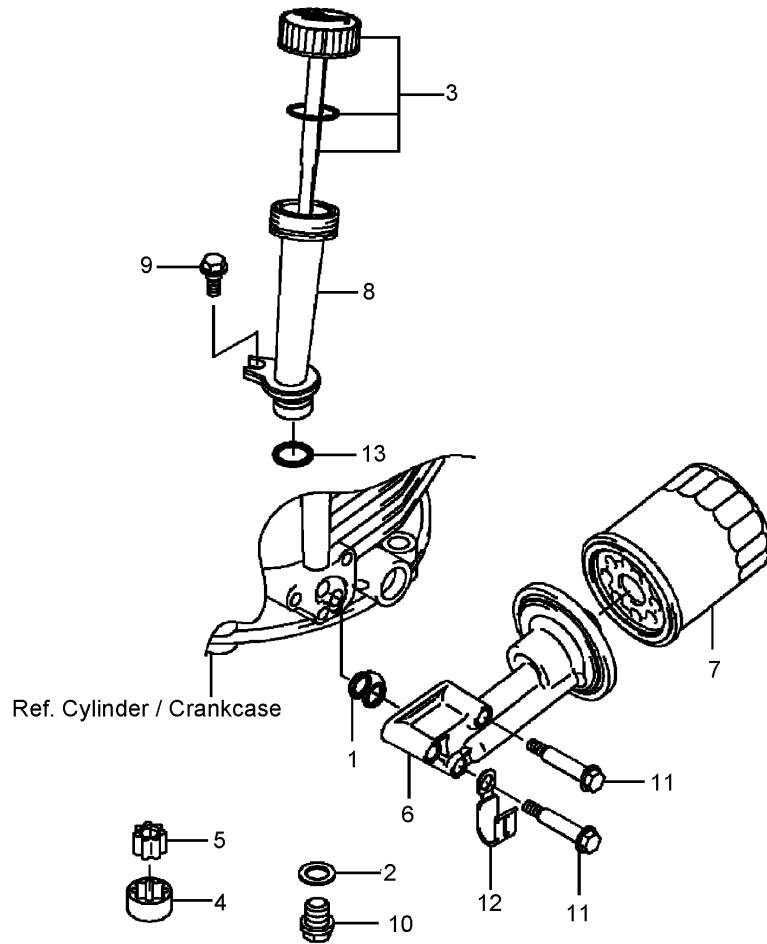

Lubrication Equipment Assembly

Ref	Part No.	Qty.	Description
1	100-2644	1	Gasket
2	108-2538	1	Gasket
3	108-2539	1	Cap ASM
4	108-2540	1	Rotor-Pump
5	108-2541	1	Rotor-Pump
6	108-2542	1	Pipe
7	KW10761	1	Filter-Oil
8	108-2543	1	Filler
9	108-2544	1	Bolt
10	108-2545	1	Bolt
11	108-2546	3	Bolt
12	108-2547	1	Clamp
13	100-2690	1	O-Ring

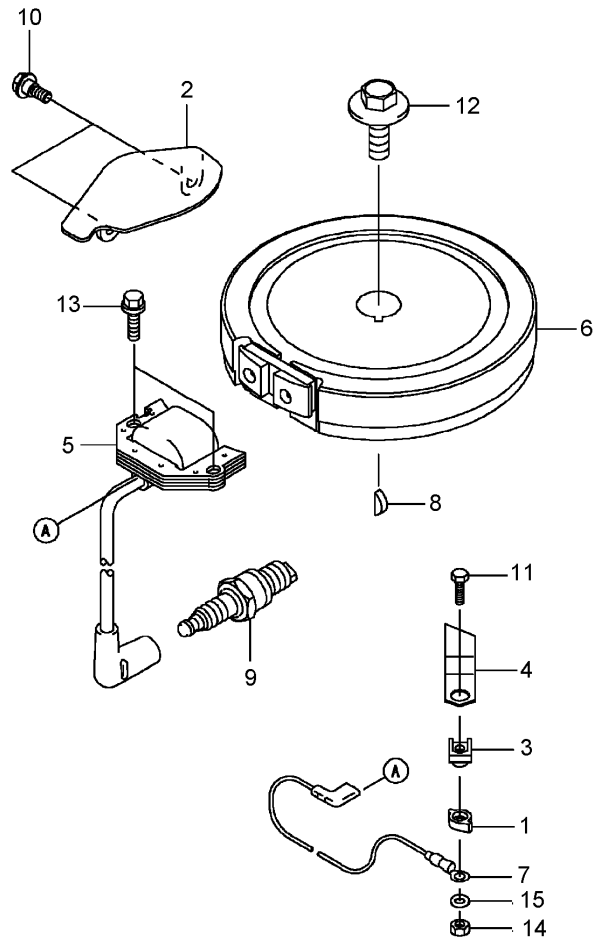

Electrical Equipment Assembly

Ref	Part No.	Qty.	Description			
1	100-2652	1	Cover			
2	108-2553	1	Cover			
3	100-2653	1	Insulator			
4	100-2796	1	Terminal			
5	108-2554	1	Coil Ignition ASM			
6	108-2555	1	Flywheel			
7	108-2556	1	Wire-Lead			
8	93-8571	1	Key			
9	KW10676	1	Spark Plug			
10	108-2544	2	Bolt			
11	108-2558	1	Bolt			
12	108-2559	1	Bolt			
13	95-9893	2	Bolt-Flanged			
14	100-2668	1	Nut-Hex			
15	100-2798	1	Washer-Plain			

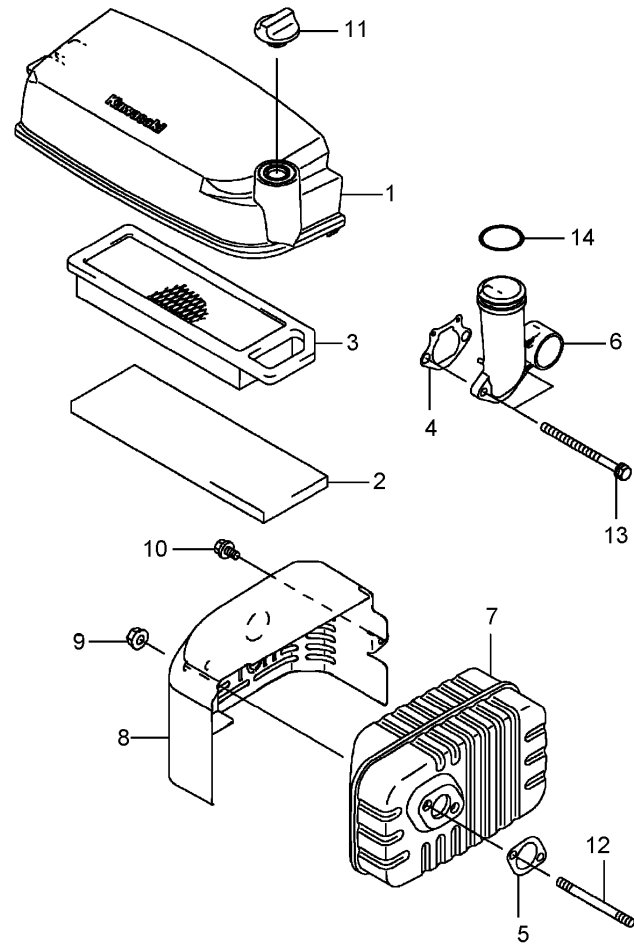

Air Filter and Muffler Assembly

Ref	Part No.	Qty.	Description
1	108-2602	1	Case-Filter, Air
2	108-2603	1	Element-Filter, Air
3	108-2604	1	Air Filter Element ASM
4	108-2605	1	Gasket-Pipe, Intake
5	108-2606	1	Gasket-Muffler
6	108-2607	1	Pipe-Intake
7	108-2608	1	Muffler
8	108-2609	1	Cover-Muffler
9	108-2610	2	Nut
10	108-2611	1	Bolt
11	108-2612	1	Nut
12	100-2761	2	Bolt-Stud
13	100-2762	2	Bolt
14	108-2613	1	O-Ring

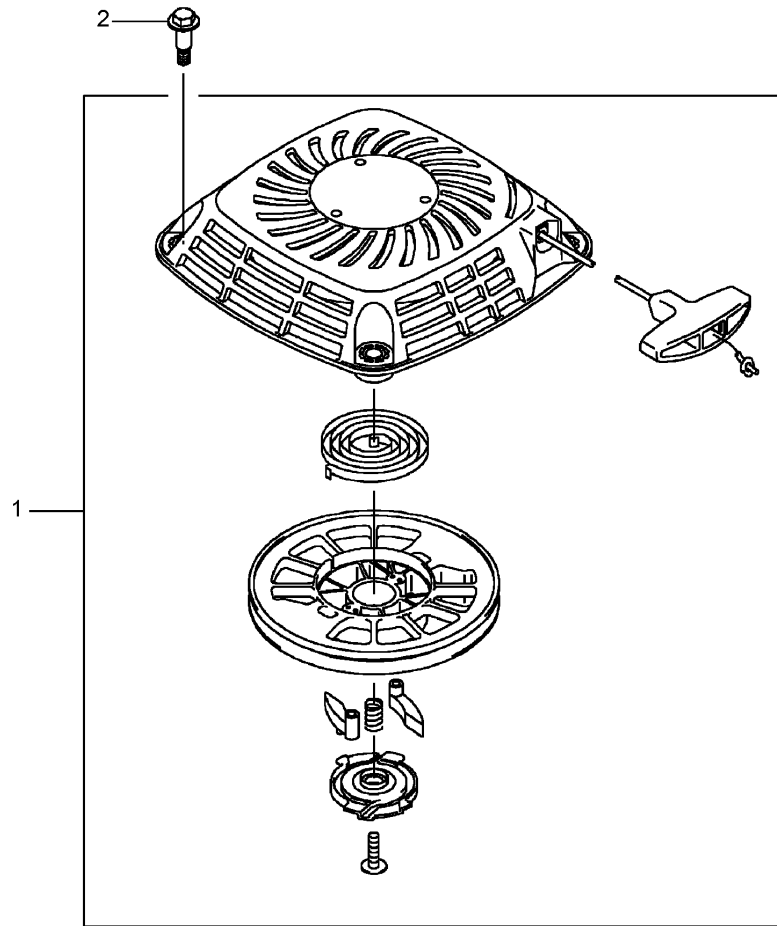

Starter Assembly

Ref	Part No.	Qty.	Description				
1	108-2614	1	Starter-Recoil				
2	108-2615	4	Bolt				

