



21in Heavy-Duty Recycler[®] Rear Bagger Lawnmower

Model No. 22167 - 260000001 and up.

Parts Catalog

Ordering Replacement Parts

To order replacement parts, please supply the part number, the quantity, and the description of each part desired.

Understanding Reference Numbers

Each Identified part in an illustration has a reference number. The reference number for a part also appears in the parts list, along with other information about the part.

This catalog uses two special reference number formats, one to indicate parts in a service assembly and another to indicate the quantity of a given part in an illustration.

Service Assembly Reference Numbers

Parts in service assemblies have reference numbers in the form a:b. The a represents the reference number of the entire service assembly and the b represents a sequential number unique to each part within the service assembly.

For example, a wheel assembly might be identified by reference number 6, the tire by 6:1, the valve by 6:2, and the wheel by 6:3. When you order the assembly identified by reference number 6, you receive all parts identified by reference numbers 6:1, 6:2, and 6:3. However, you may also order any part individually. Reference numbers of this type appear in illustrations and in part lists.

Reference Numbers Indicating Quantity

In an illustration, if a reference number indicates more than one part, the reference number has the form nX y. The n represents the quantity of the part, the X is the multiplication symbol, and the y represents the reference number.

For example, in an illustration, the reference number 2X 37 means that two of the parts identified by reference number 37 are indicated.

Contents

Description	Page	Description	Page
Housing Assembly 3	Crankshaft and Piston Assembly Honda GXV160K1-A1T 15
Housing Assembly No. 98-7139 4	Camshaft Assembly Honda GXV160K1-A1T 16
Front Wheel and Tire Assembly No. 100-2870 5	Recoil Starter Assembly Honda GXV160K1-A1T 17
Gear Case Assembly No. 74-1861 6	Fan Cover Assembly Honda GXV160K1-A1T 18
Engine and Blade Assembly 7	Carburetor Assembly Honda GXV160K1-A1T 19
Handle and Control Assembly 8	Air Cleaner Assembly Honda GXV160K1-A1T 20
Rear Axle Assembly 9	Muffler Assembly Honda GXV160K1-A1T 21
Rear Wheel Assembly No. 100-2860 10	Flywheel Assembly Honda GXV160K1-A1T 22
Grass Bag Assembly No. 106-0975 11	Control Assembly Honda GXV160K1-A1T 23
Cylinder Head Assembly Honda GXV160K1-A1T 12	Label Assembly Honda GXV160K1-A1T 24
Cylinder Barrel Assembly Honda GXV160K1-A1T 13		

Part Description Abbreviations

Part descriptions in this catalog may include the following abbreviations.

AR. as required	INC. incorporated
ASM. assembly	LH. left hand
BBC. blade brake clutch	NI. nylon insert
CARR. carriage	NPTF. national pipe thread fine
DEG. degrees	PFH. phillips flat head
EXT. external	PPH. phillips pan head
FH. flat head	PPHTF. phillips pan head thread forming
GA. gauge	PRH. phillips round head
HF. hex flange	PTH. phillips truss head
HH. hex head	PTO. power-take-off
HHF. hex head flange	RH. right hand
HHFTF. hex head flange thread forming	ROPS. roll-over-protection-system
HJ. hex jam	SFH. slotted fillister head
HLH. hex lag head	SHH. slotted hex head
HOC. height-of-cut	SHWH. slotted hex washer head
HSBH. hex socket button head	SPH. slotted pan head
HSFH. hex socket flat head	SQH. square head
HSH. hex socket head	SRH. slotted round head
HWH. hex washer head	STD. standard
HWHTF. hex washer head thread forming	TAP. self tapping
HYD. hydraulic	TTH. torx truss head

Footnotes

- ❶ Not illustrated
- ❷ Obtain from your local Honda dealer
- ❸ Not serviced separately

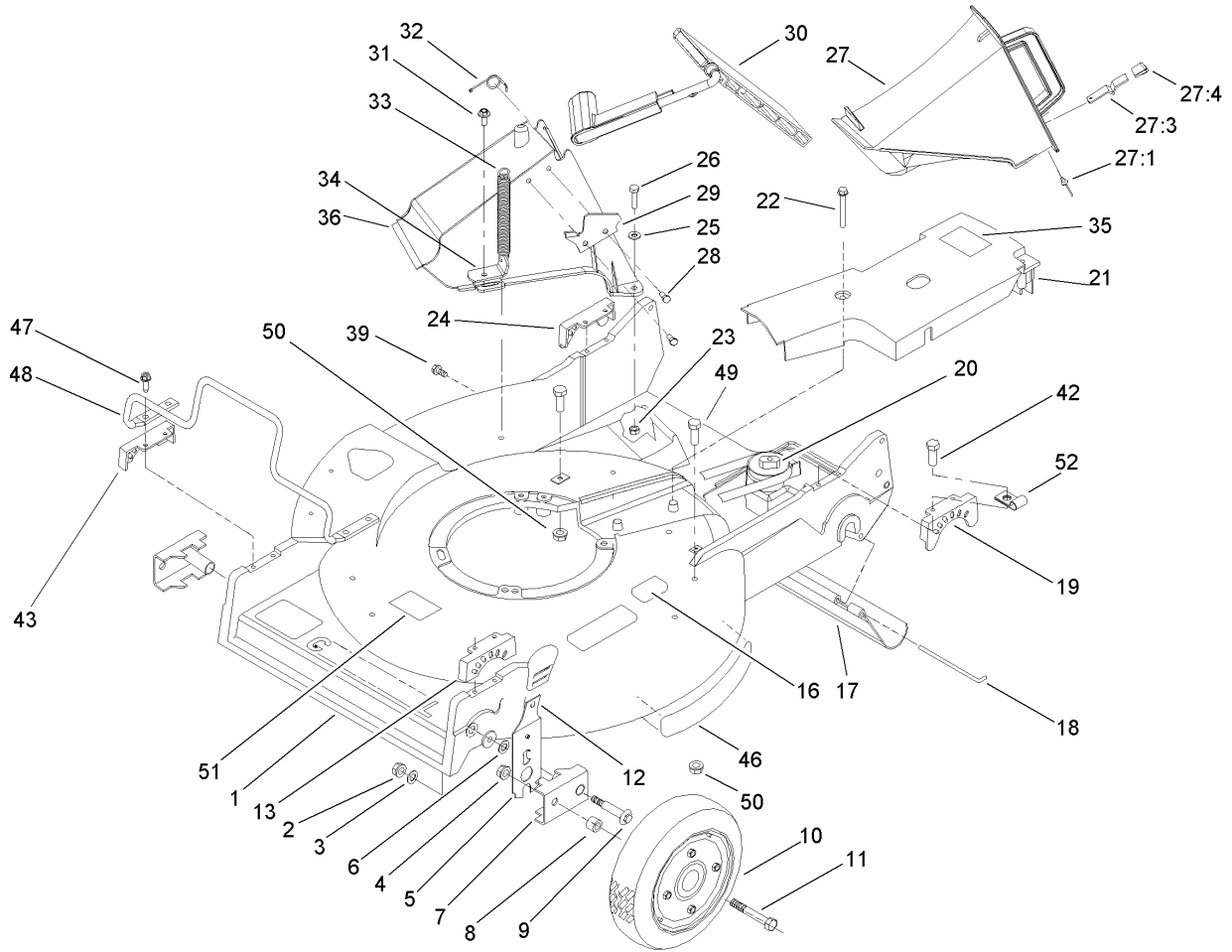

Housing Assembly

Ref	Part No.	Qty.	Description
1	98-7139	1	Housing
2	3296-6	2	Nut-Lock
3	40-1940	2	Washer
4	32152-2	2	Nut-Lock, Cone
5	110-0537	2	Spring Arm ASM
6	257-3	2	Washer-Thrust
7	61-8300	2	Arm-Pivot, Front
8	52-2480	2	Spacer-Wheel
9	27-6232	2	Bolt-Wheel
10	100-2870	2	Wheel And Tire ASM
11	323-12	2	Screw-HH
12	110-0549	2	Knob-HOC
13	49-8760	1	Quadrant-Front, LH
16	105-2625	1	Decal-STD, Safety
17	44-0580	1	Shield-Trailing
18	33-3208	1	Rod-Shield
19	49-8740	1	Quadrant-Rear, LH
20	74-1861	1	Gear Case ASM
21	74-1770	1	Cover-Belt
22	37-7260	2	Screw-HH
23	3296-42	2	Nut-Lock, NI
24	49-8750	1	Quadrant-Rear, RH
25	3256-22	2	Washer-Flat
26	321-8	2	Screw-HH

Ref	Part No.	Qty.	Description
27	77-0500	1	Discharge Plug ASM
27:1	3295-35	1	Rivet-Head, Flat
27:3	76-4640	1	Latch-Plug, Discharge
27:4	76-4650	1	Grip-Latch
28	46-8090	2	Screw-Plastite
29	93-3154	1	Latch-Plate
30	93-7351	1	Discharge Door ASM
31	46-6811	1	Screw-HWH
32	80-3770	1	Retainer-Door
33	76-4660	1	Spring-Door
34	71-9350	1	Bracket-Spring
35	52-2620	1	Label-Grease
36	82-9152	1	Tunnel-Discharge
39	46-6810	1	Screw And Washer ASM
42	49-2040	4	Screw-HWHTF
43	49-8770	1	Quadrant-Front, RH
46	106-0689	1	Decal
47	32144-86	4	Screw-HWHTF
48	99-6722	1	Guard-Engine
49	323-6	2	Screw-HH
50	3296-39	2	Nut-Lock, NI
51	68-7410	1	Decal-Blade
52	2412-72	1	Clip-Closed, Insulated

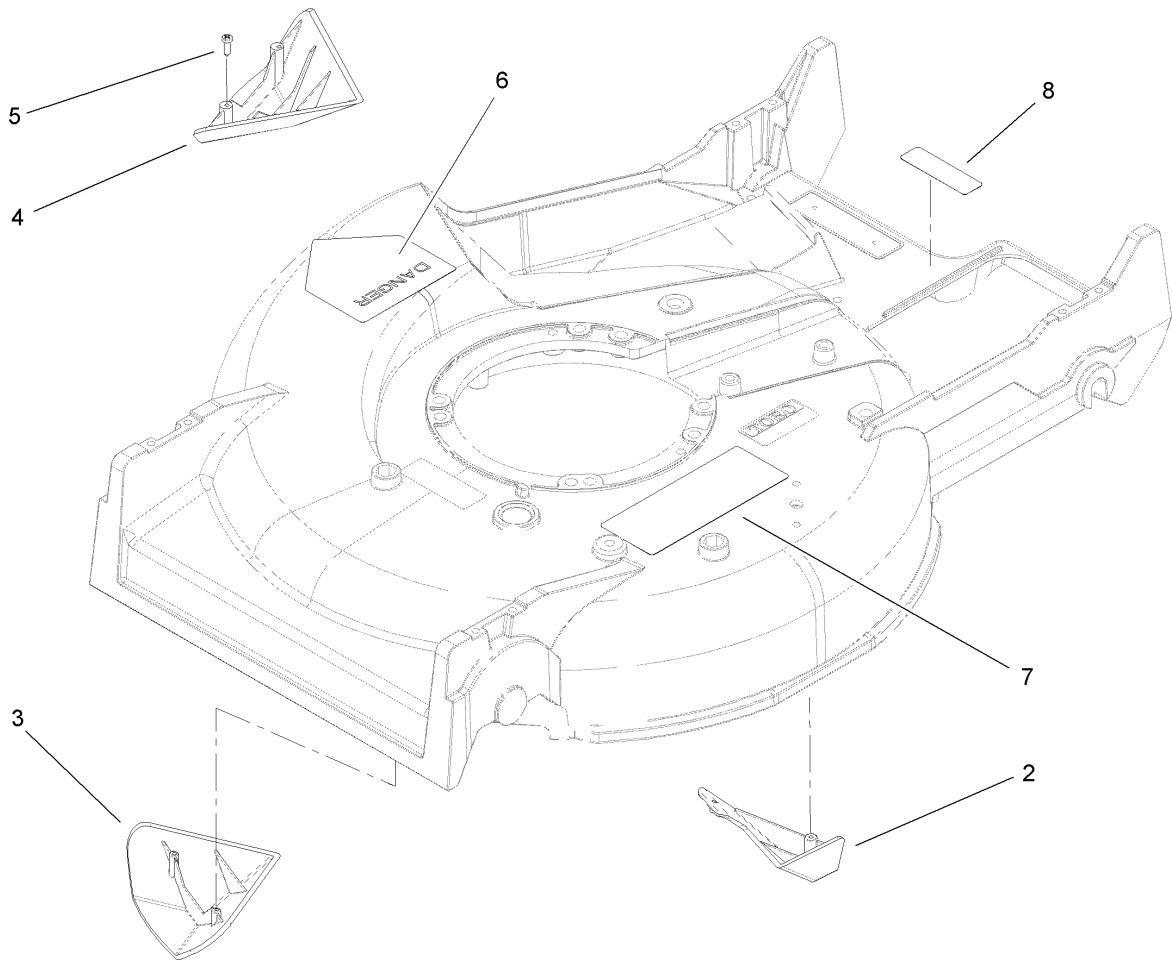

Housing Assembly No. 98-7139

Ref	Part No.	Qty.	Description
2	92-1750	1	Kicker-Rear
3	92-1720	1	Kicker-Front
4	92-1730	1	Kicker-RH
5	32144-111	6	Screw-PPH
6	39-5770	1	Decal-Danger
7	93-0248	1	Decal-Warning
8	92-1779	1	Decal-Warning

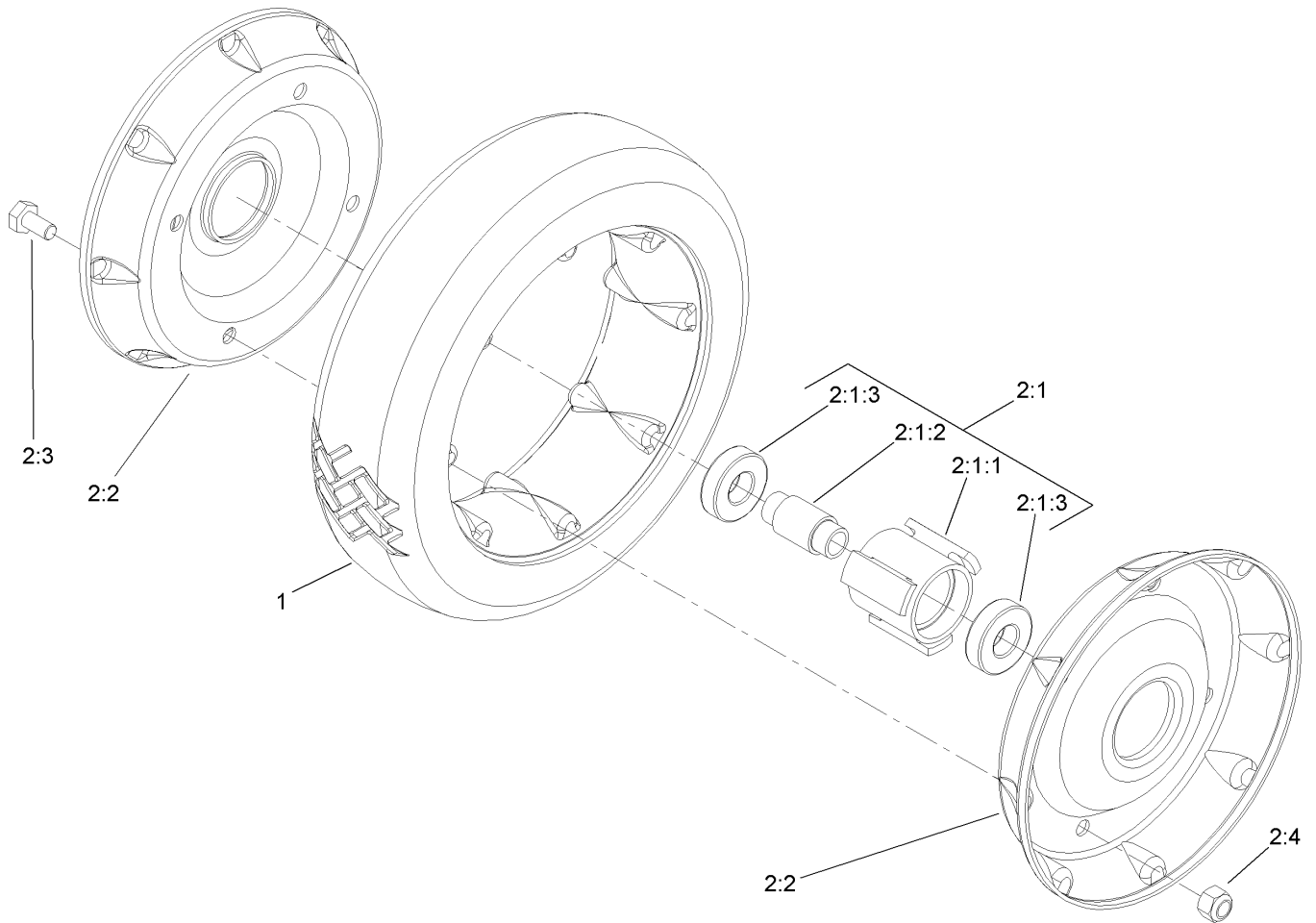

Front Wheel and Tire Assembly No. 100-2870

Ref	Part No.	Qty.	Description
1	53-7740	1	Tire
2		1	Wheel ASM
2:1		1	Hub And Bearing ASM
2:1:1	52-2410	1	Hub-Bearing
2:1:2	52-2440	1	Spacer-Bearing
2:1:3	52-2450	2	Bearing-Wheel
2:2	53-7780-06	2	Plate-Wheel, Half
2:3	321-2	4	Screw-HH
2:4	3296-42	4	Nut-Lock, NI

Ref	Part No.	Qty.	Description

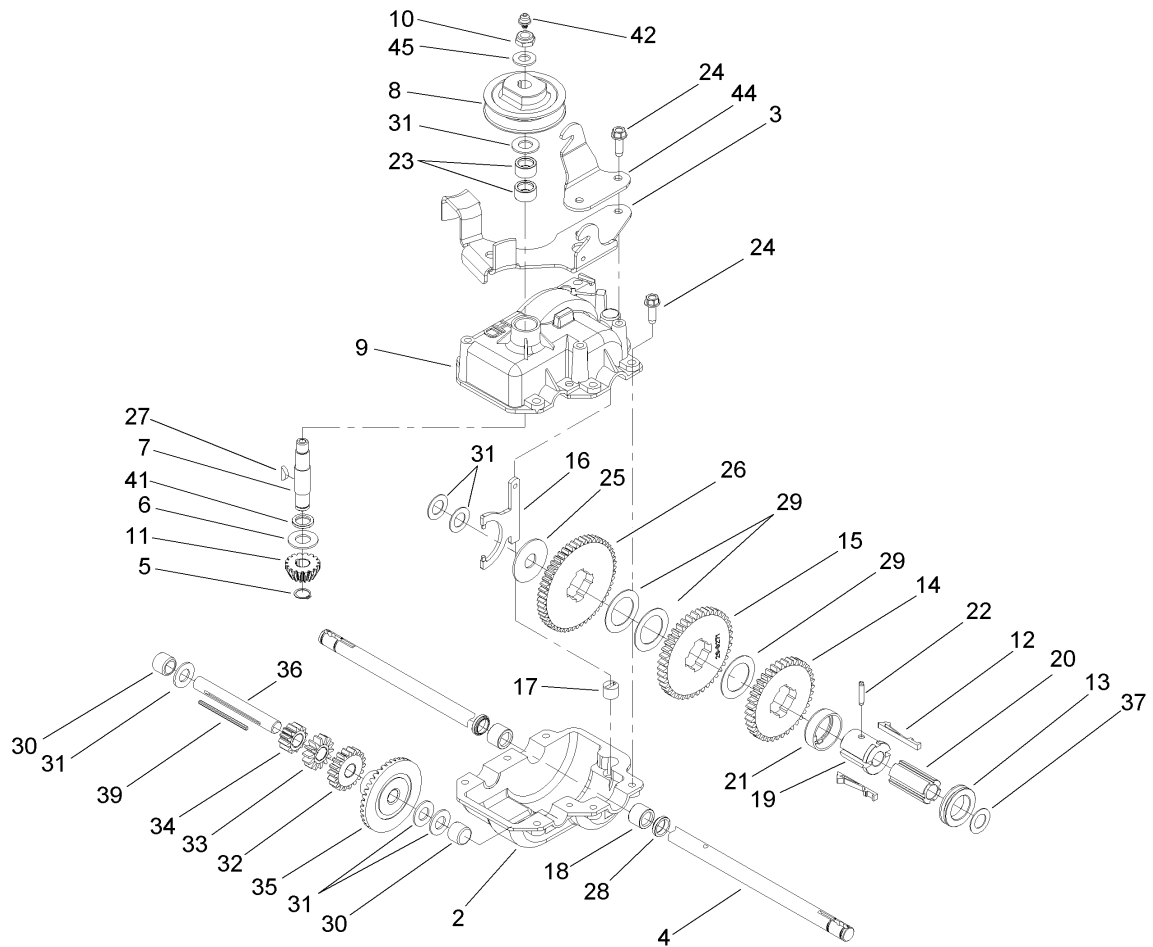

Gear Case Assembly No. 74-1861

Ref	Part No.	Qty.	Description
2	74-1920	1	Case-Gear, Lower
3	49-8461-03	1	Bracket-Guide, Belt
4	74-1890	1	Shaft-Output
5	32151-57	1	Ring-Retaining
6	47-2910	1	Washer-Thrust
7	13-5149	1	Input Shaft ASM
8	39-6740	1	Pulley
9	13-9739	1	Upper Gearcase ASM
10	3296-5	1	Nut-Lock
11	39-6660	1	Pinion-Bevel
12	29-9330	2	Key-Shift
13	29-9340	1	Collar-Shift
14	42-4740	1	Gear-38T
15	29-9271	1	Gear-42T
16	60-8870	1	Yoke-Shift
17	29-9570	1	Bushing-Yoke
18	47-6730	2	Seal-Oil
19	55-8010	1	Sleeve-Gear
20	39-6720	1	Sleeve
21	55-8020	1	Retainer-Key
22	3285-19	1	Pin-Groove
23	47-7270	2	Bearing
24	49-2040	6	Screw-HWHTF
25	29-9690	1	Washer

Ref	Part No.	Qty.	Description
26	46-3560	1	Gear
27	3257-1	2	Key-Woodruff
28	48-2060	2	Bearing-Roller
29	36-4770	3	Washer
30	252-103	2	Bearing-Closed
31	36-4792	4	Washer-Thrust
32	39-6650	1	Gear-18T
33	46-3550	1	Gear-14T
34	46-3540	1	Gear-12T
35	74-1760	1	Gear-Bevel
36	53-7950	1	Shaft-Intermediate
37	36-4780	3	Washer
39	39-7842	1	Key
41	47-7260	1	Seal
42	302-63	1	Zerk
44	74-1750-03	1	Bracket-Engage, Traction
45	3256-45	1	Washer-Flat

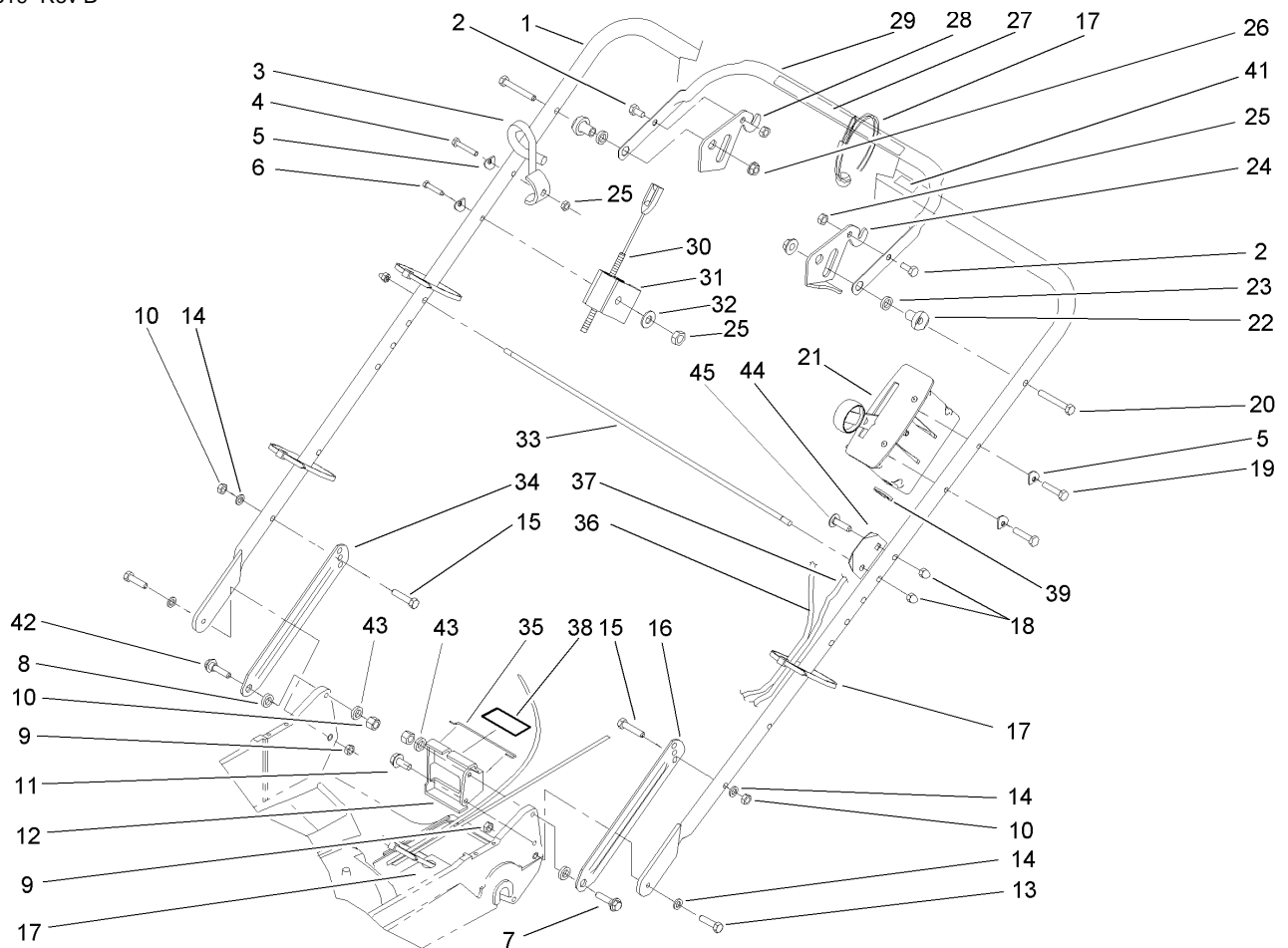

Handle and Control Assembly

Ref	Part No.	Qty.	Description
1	98-2000-03	1	Handle
2	321-4	2	Screw-HH
3	46-8081	1	Guide-Rope
4	321-9	1	Screw-HH
5	3-7501	4	Washer
6	321-15	1	Screw-HH
7	27-7210	1	Screw-Shoulder
8	3-3287	2	Spacer-Latch, Handle
9	3296-47	2	Nut-Lock, NI
10	3296-29	4	Nut-Lock, NI
11	32144-70	1	Screw-HWHTF
12	74-1741	1	Bracket-Adjustment, Traction
13	322-6	2	Screw-HH
14	3290-456	4	Washer-Belleville
15	322-7	2	Screw-HH
16	100-3298-03	1	Latch-Handle, LH
17	3290-378	5	Tie-Cable
18	32111-7	3	Nut-Cap
19	321-13	2	Screw-HH
20	322-11	2	Screw-HH
21	108-2645	1	Control-Head, Throttle
22	49-1630	2	Spacer-Support
23	256-276	2	Spacer-Nylon
24	66-5350	1	Lever-Control

Ref	Part No.	Qty.	Description
25	3296-42	4	Nut-Lock, NI
26	3296-58	2	Nut-Lock, NI
27	106-0690	1	Decal-Traction
28	77-5270	1	Lever-Control
29	61-8270-03	1	Bar-Control
30	103-2683	1	Cable-Brake
31	46-6980	1	Support-Cable
32	3256-22	1	Washer-Flat
33	48-2810	1	Rod-Support, Bag
34	100-3297-03	1	Latch-Handle, RH
35	46-7030	1	Retainer-Cable
36	74-1791	1	Cable-Traction
37	106-0888	1	Throttle Cable ASM
38	74-1970	1	Decal-Position, Gear
39	32151-86	2	E-Ring
41	98-4387	1	Decal-Protection, Ear
42	27-7211	1	Screw-Shoulder
43	3256-23	2	Washer-Flat
44	104-1326	1	Plate-Aligning, Bag
45	3229-3	1	Screw-CARR

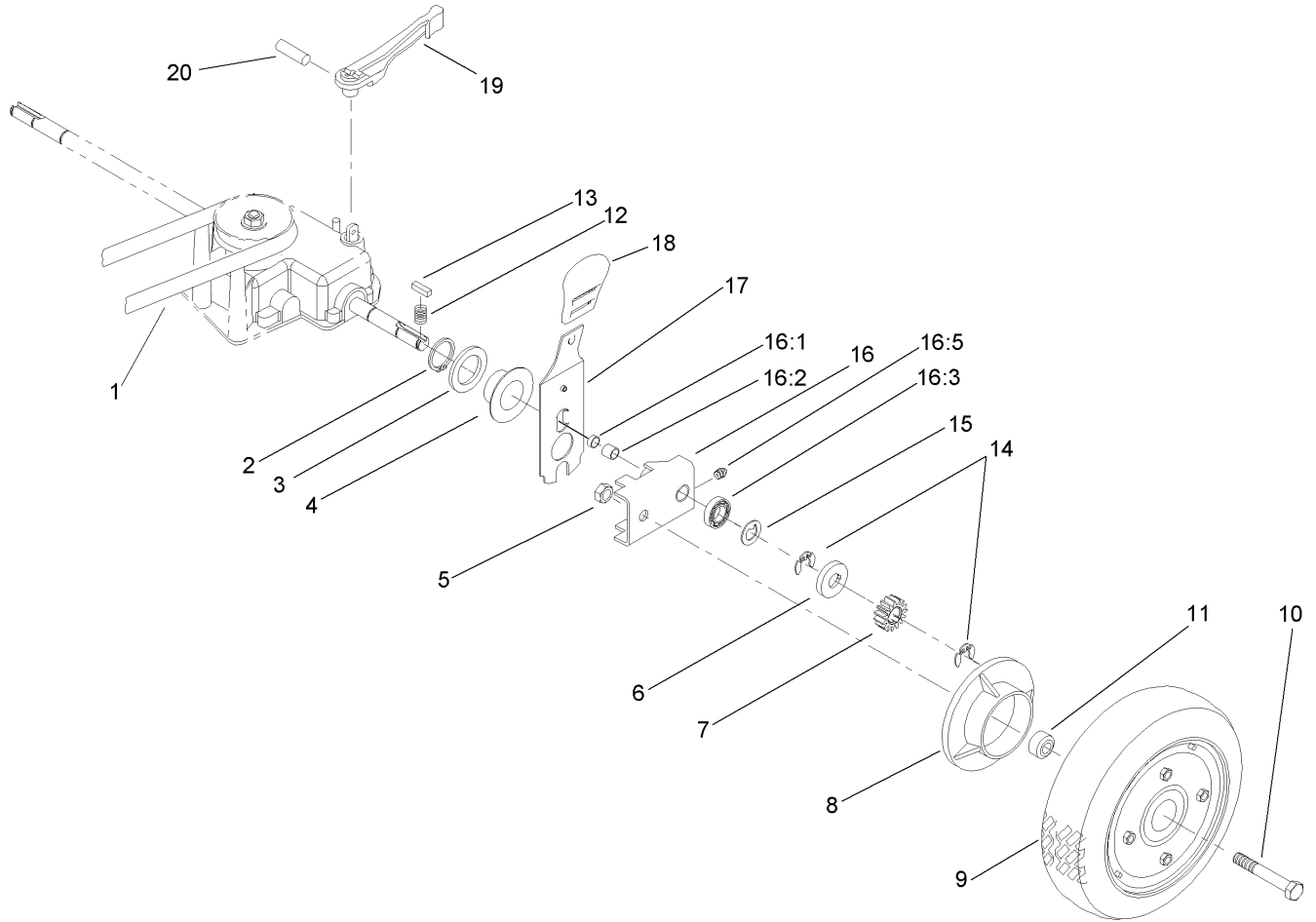

Rear Axle Assembly

Ref	Part No.	Qty.	Description
1	36-8070	1	V-Belt
2	32151-36	2	Ring-Retaining
3	74-1810	2	Washer
4	48-2170	2	Cap-End
5	32152-2	2	Nut-Lock, Cone
6	62-3830	2	Washer-Thrust, Outer
7	39-9160	2	Gear-Pinion
8	74-1640	2	Cover-Wheel
9	100-2860	2	Wheel And Tire ASM
10	323-13	2	Screw-HH
11	74-1650	2	Spacer-Cover, Wheel
12	39-9650	2	Spring-Compression
13	612066	2	Key
14	32151-68	4	Ring-Retaining
15	49-7700	2	Washer-Thrust, Outer
16	74-1851	2	Pivot Arm ASM
16:1	47-6730	1	Seal-Oil
16:2	48-2060	1	Bearing-Roller
16:3	52-2450	1	Bearing-Wheel
16:5	92-6316	1	Zerk
17	110-0538	2	Rear Spring Arm ASM
18	110-0549	2	Knob-HOC
19	74-1960	1	Lever-Shift
20	32121-99	1	Pin-Coil

Ref	Part No.	Qty.	Description
●99	106-0975	1	Grass Bag ASM

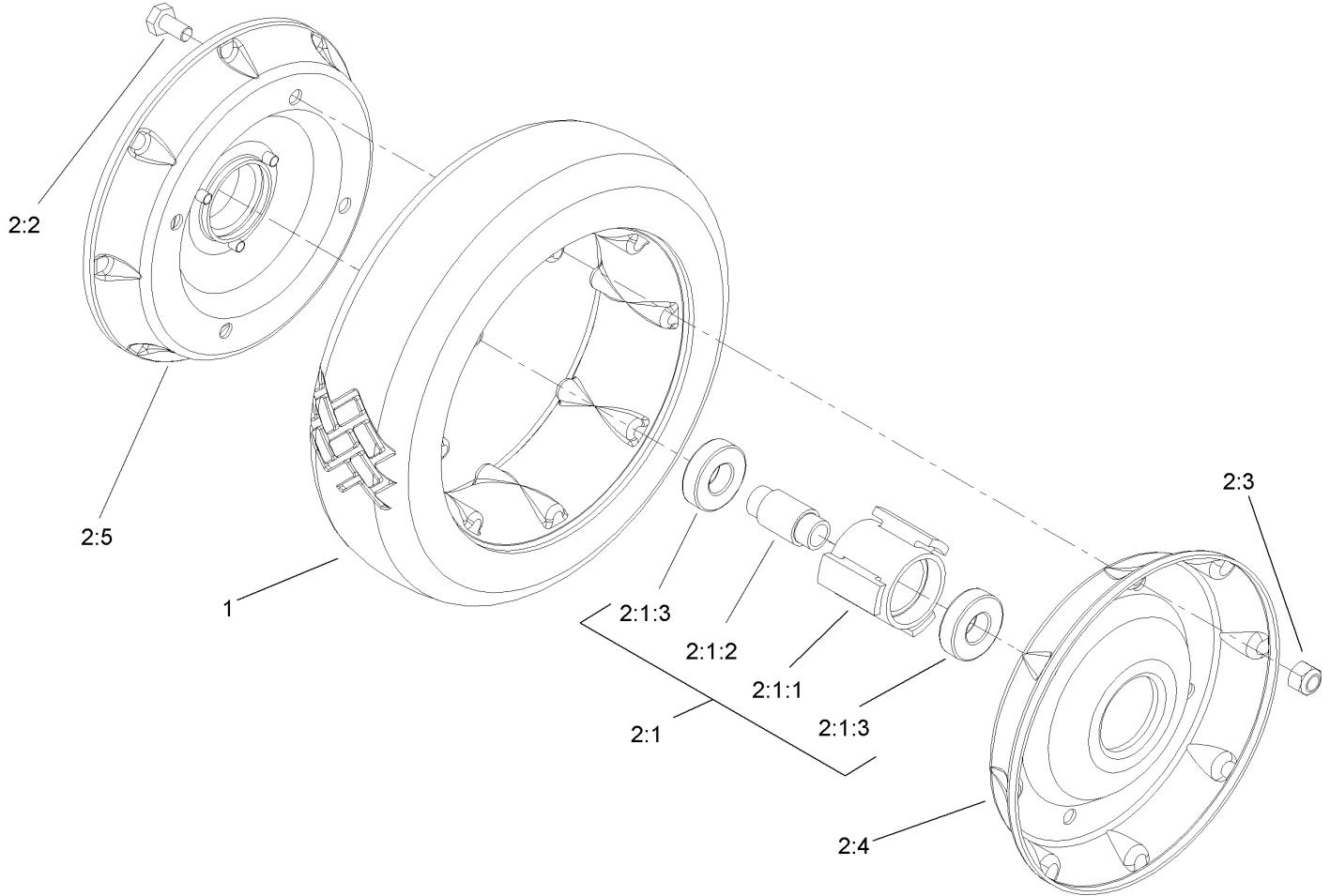

Rear Wheel Assembly No. 100-2860

Ref	Part No.	Qty.	Description
1	53-7740	1	Tire
2		1	Wheel ASM
2:1		1	Hub And Bearing ASM
2:1:1	52-2410	1	Hub-Bearing
2:1:2	52-2440	1	Spacer-Bearing
2:1:3	52-2450	2	Bearing-Wheel
2:2	321-2	4	Screw-HH
2:3	3296-42	4	Nut-Lock, NI
2:4	53-7780-06	1	Plate-Wheel, Half
2:5	92-4957-06	1	Wheel Half And Gear ASM

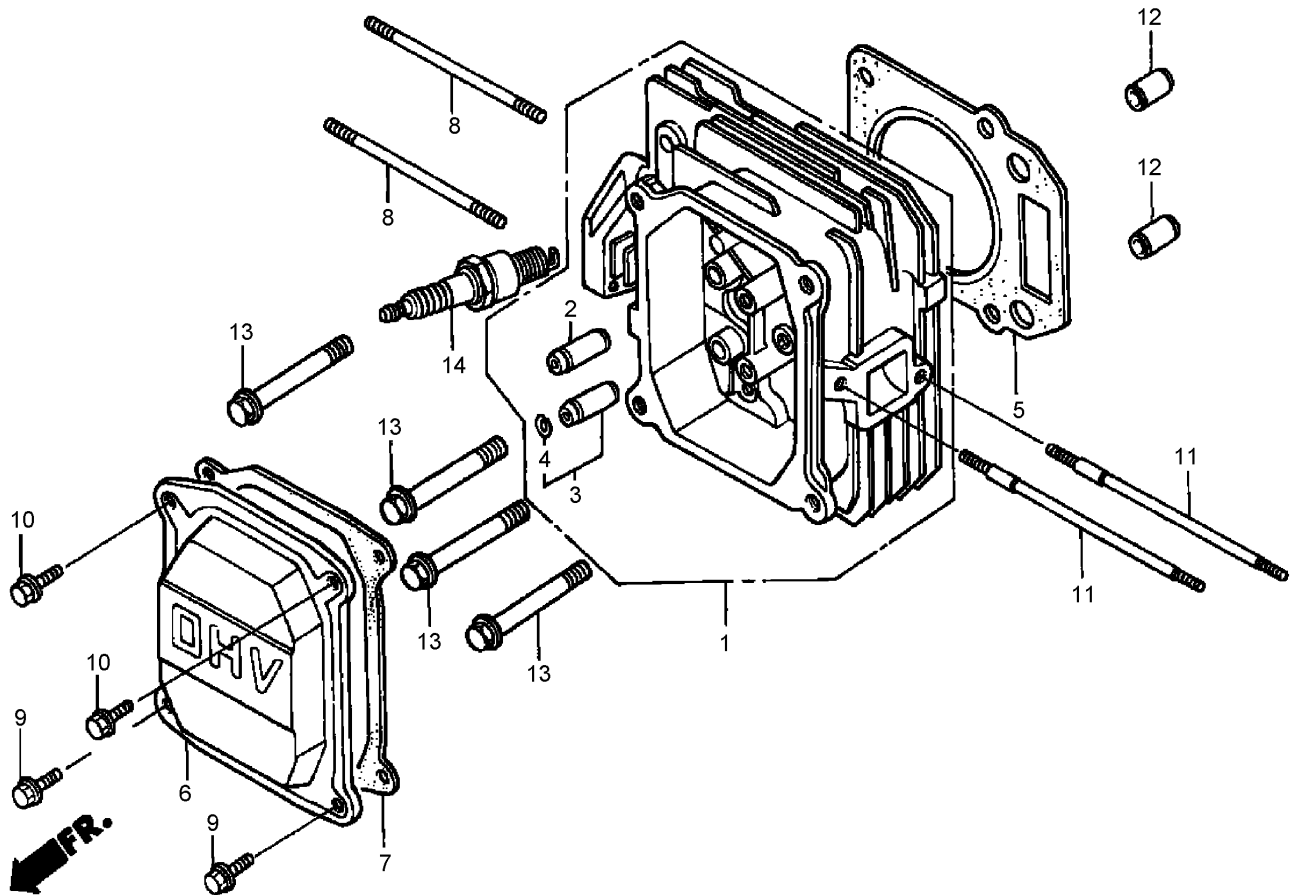

Cylinder Head Assembly Honda GXV160K1-A1T

Ref	Part No.	Qty.	Description
❶	12200-ZE7-405	1	Head-Cylinder
❷	12204-ZE1-306	1	Guide-Valve (Os)
❸	12205-ZE1-315	1	Guide-Valve, Exhaust (Os)
❹	12216-ZE5-300	1	Clip-Guide, Valve
❺	12251-ZE7-000	1	Gasket-Head, Cylinder
❻	12311-ZG9-800	1	Cover-Head
❼	12391-ZE7-T00	1	Gasket-Cover, Cylinder Head
❸	90048-ZC3-000	2	Bolt-Stud (6X85)
❹	90013-883-000	2	Bolt-Flange (6X12) (Ct200)
❺	90013-883-000	2	Bolt-Flange (6X12) (Ct200)
❻	90043-ZE6-000	2	Bolt-Stud (6X109)
❼	94301-10160	2	Pin-Dowel (10X16)
❸	95701-08050-00	4	Bolt-Flange (8X50)
❹	98079-54846	1	Plug-Spark (Bpr4Es)
❹	98079-54855	1	Plug-Spark (W14Epr-U)

Ref	Part No.	Qty.	Description
❹	98079-55846	1	Plug-Spark (Bpr5Es)
❹	98079-55855	1	Plug-Spark (W16Epr-U)
❹	98079-56846	1	Plug-Spark (Bpr6Es) (Ngk)
❹	98079-56855	1	Plug-Spark (W20Epr-U)

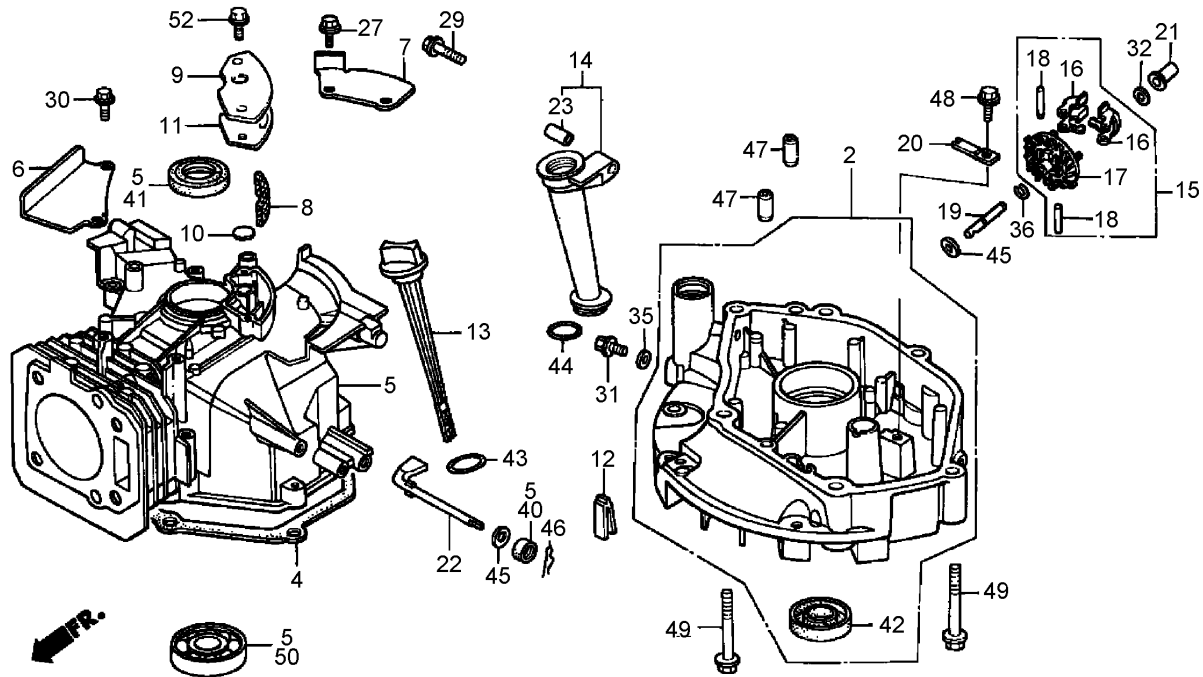

Cylinder Barrel Assembly Honda GXV160K1-A1T

Ref	Part No.	Qty.	Description
2	11300-ZE7-408	1	Oil Pan ASM
4	11381-ZE7-M10	1	Gasket-Pan, Oil
5	12000-ZE7-405	1	Cylinder ASM
6	12125-ZE7-000	1	Plate-Guide
7	12126-ZE7-W00	1	Plate A-Guide
8	12367-883-003	1	Filter-Breather
9	12370-ZE7-000	1	Cover-Breather
10	12372-ZE7-000	1	Valve-Breather
11	12373-ZE7-000	1	Gasket-Cover, Breather
12	15335-ZE7-000	1	Rubber-Return, Oil
13	15620-ZE6-810	1	Dipstick-Oil
14	15630-ZE6-810	1	Extension-Filler, Oil (106Mm)
15	16510-ZE6-000	1	Governor ASM

Ref	Part No.	Qty.	Description
16	16511-ZE1-000	2	Weight-Governor
17	16512-ZE6-000	1	Holder-Weight, Governor
18	16513-ZE1-000	2	Pin-Weight, Governor
19	16515-ZE6-010	1	Shaft-Holder, Governor
20	16525-ZE6-010	1	Plate-Holder, Governor Shaft
21	16531-ZE1-000	1	Slider-Governor
22	16541-ZE7-000	1	Shaft-Arm, Governor
23	17240-ZE6-000	1	Collar-Extension
27	90013-883-000	2	Bolt-Flange (6X12) (Ct200)
29	90017-883-000	1	Bolt-Flange (6X32)
30	90022-888-010	2	Bolt-Flange (6X20)
31	90131-ZE1-000	1	Bolt-Plug, Drain
32	90451-ZE1-000	1	Washer-Thrust (6Mm)

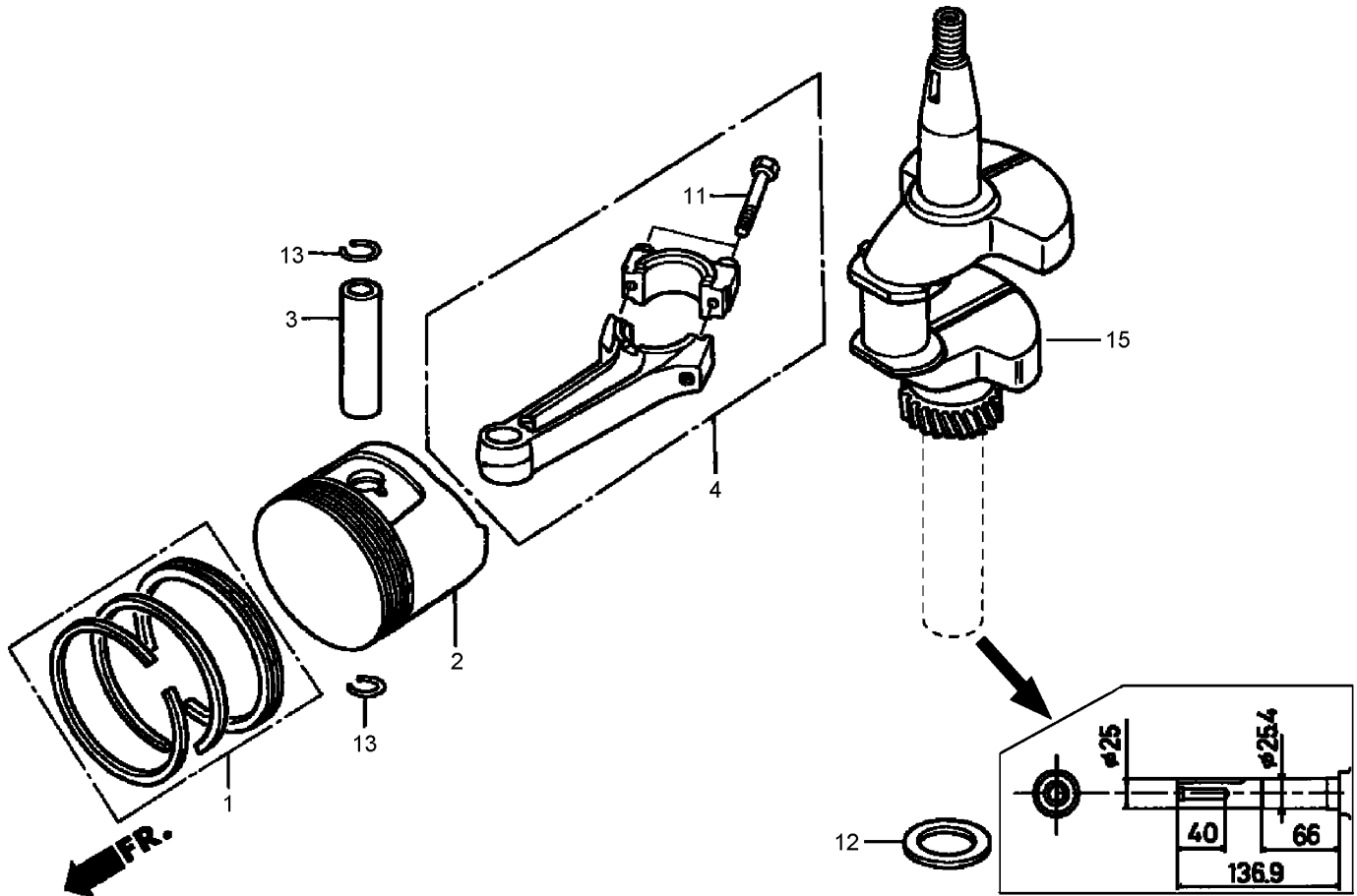

Crankshaft and Piston Assembly Honda GXV160K1-A1T

Ref	Part No.	Qty.	Description
●1	13010-ZL0-003	1	Ring Set-Piston (STD)
●1	13010-ZL0-004	1	Ring Set-Piston (STD) (Nippon)
●1	13011-ZL0-003	1	Ring Set-Piston (Os0.25)
●1	13011-ZL0-004	1	Ring Set-Piston (Os0.25)(Nippon)
●1	13012-ZL0-003	1	Ring Set-Piston (Os0.50)
●1	13012-ZL0-004	1	Ring Set-Piston (Os0.50) (Nippon)
●1	13013-ZL0-003	1	Ring Set-Piston (0.75)
●1	13013-ZL0-004	1	Ring Set-Piston (0.75)(Nippon)
●2	13101-ZE7-020	1	Piston (STD)
●2	13102-ZE7-020	1	Piston (Os 0.25)
●2	13103-ZE7-020	1	Piston (Os 0.50)
●2	13104-ZE7-020	1	Piston (0.75)
●3	13111-ZE1-000	1	Pin-Piston

Ref	Part No.	Qty.	Description
●4	13200-ZE7-000	1	Connecting Rod ASM
●4	13200-ZE7-305	1	Connecting Rod ASM (Us 0.25)
●11	90001-ZE1-000	2	Bolt-Rod, Connecting
●12	90401-ZE7-W00	1	Washer-Thrust (25.6Mm)
●13	90551-ZE1-000	2	Clip-Pin, Piston (18Mm)
●15	13310-ZE7-V10	1	Crankshaft

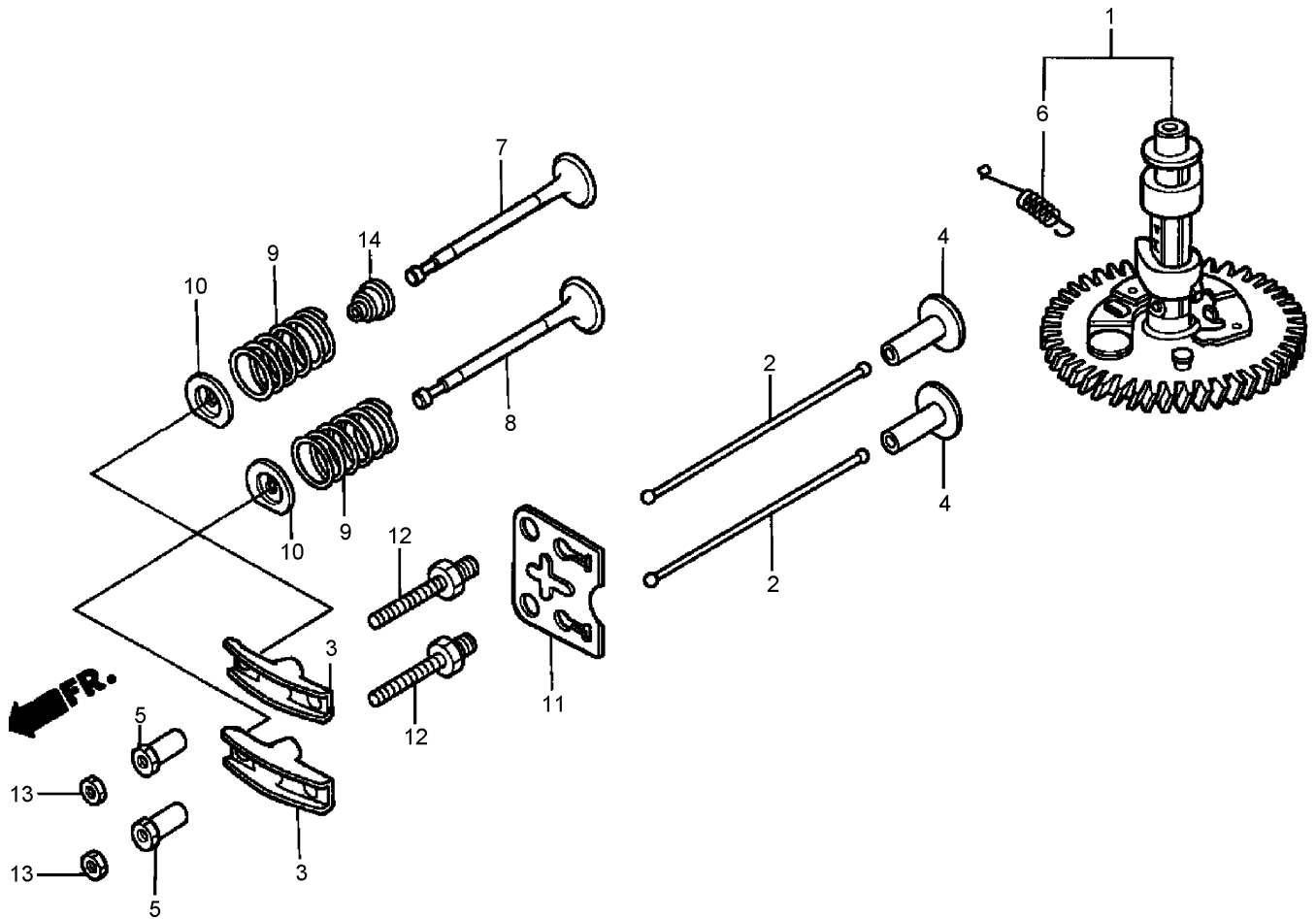

Camshaft Assembly Honda GXV160K1-A1T

Ref	Part No.	Qty.	Description
❶	14100-ZE7-000	1	Camshaft ASM
❷	14410-ZE1-010	2	Rod-Push
❸	14431-ZE1-000	2	Arm-Rocker, Valve
❹	14441-ZE1-010	2	Lifter-Valve
❺	14451-ZE1-013	2	Pivot-Arm, Rocker
❻	14568-ZE1-000	1	Spring-Return, Weight
❼	14711-ZF1-000	1	Valve-Intake
❽	14721-ZE7-000	1	Valve-Exhaust
❾	14751-ZE1-000	2	Spring-Valve
❿	14771-ZE1-000	2	Retainer-Valve Spring, Intake
⓫	14791-ZE1-010	1	Plate-Guide, Push Rod
⓬	90012-ZE0-010	2	Bolt-Pivot (8Mm)
⓭	90206-ZE1-000	2	Nut-Adj., Pivot

Ref	Part No.	Qty.	Description
⓮	12209-ZE6-003	1	Seal-Stem, Valve

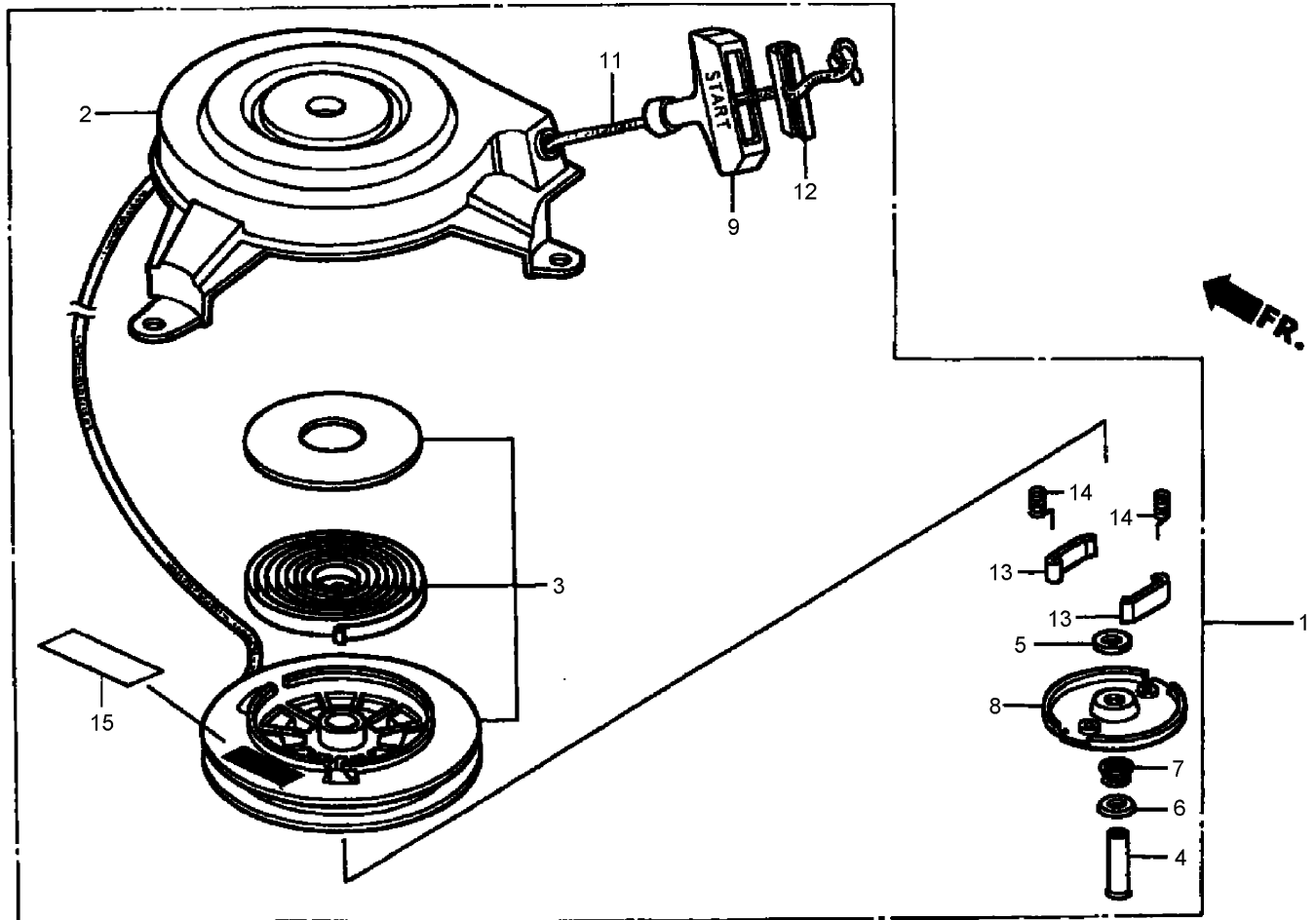

Recoil Starter Assembly Honda GXV160K1-A1T

Ref	Part No.	Qty.	Description
❶	28400-ZG9-W52	1	Recoil Starter ASM
❷	28402-ZG9-802	1	Housing ASM
❸	28415-ZG9-802	1	Pulley And Spring ASM
❹	28419-ZG9-802	1	Pin-Center
❺	28431-ZG9-802	1	Plate A-Friction
❻	28432-ZG9-802	1	Plate B-Friction
❼	28441-ZG9-802	1	Spring-Friction
❽	28444-ZG9-802	1	Retainer
❾	28461-ZE6-T02	1	Handle
❿	28462-ZG9-W52	1	Rope (No.4.5X96In)
⓫	28463-ZE6-T02	1	Handle-Reinforcement
⓬	28485-ZE6-T02	2	Ratchet-Starter
⓭	28486-ZE6-T02	2	Spring-Dog

Ref	Part No.	Qty.	Description
❶	87284-ZG9-W52	1	Mark-Number, Parts

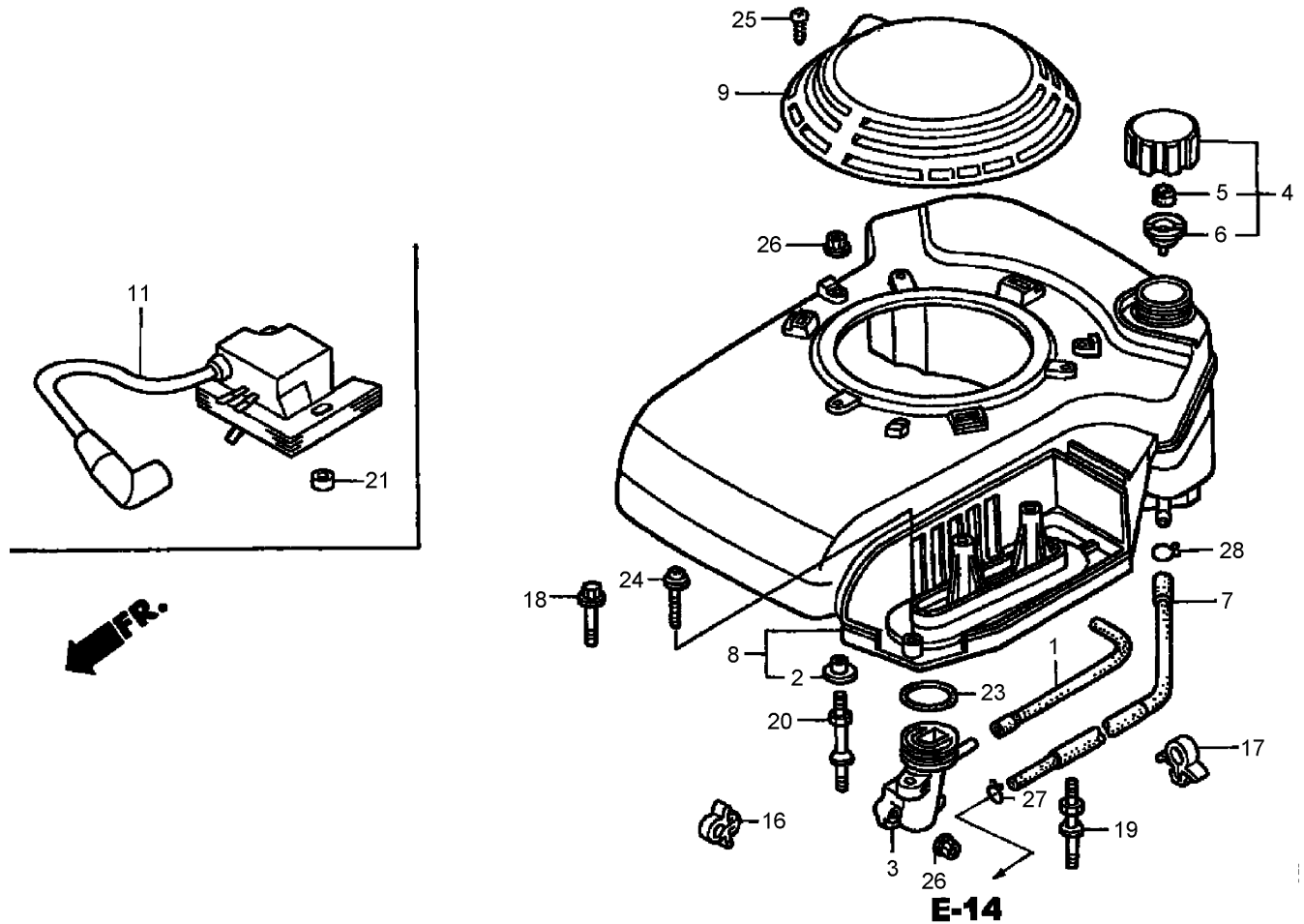

Fan Cover Assembly Honda GXV160K1-A1T

Ref	Part No.	Qty.	Description
❶	15721-ZE7-000	1	Tube-Breather
❷	17216-PE2-003	3	Collar-Cleaner, Air
❸	17410-ZE7-W00	1	Elbow-Cleaner, Air
❹	17620-ZE7-000	1	Fuel Tank Cap ASM
❺	17622-888-010	1	Sponge-Breather, Fuel Cap
❻	17624-ZE7-000	1	Gasket-Cap, Fuel
❼	17700-ZE7-W00	1	Fuel Tank Tube ASM
❸	19610-ZE7-W11ZA	1	Cover-Fan
❹	19615-ZG9-801ZA	1	Hood-Cover, Fan
❶	30500-ZG9-801	1	Ignition Coil ASM
❶	36103-ZE1-000	1	Holder-Wire, Stop Switch
❶	46392-SC2-003	1	Clamp-Pipe, Brake
❶	90015-883-000	1	Bolt-Flange (6X28)

Ref	Part No.	Qty.	Description
❶	90041-ZE7-W10	2	Bolt-Stud
❶	90042-ZE7-W00	1	Bolt-Stud
❶	90402-ZE7-W00	2	Collar-Special
❶	91301-ZG9-800	1	O-Ring (33.3X3.5)
❶	93891-06035-10	1	Screw-Washer (6X35)
❶	93913-24580	1	Screw-Tapping (4X20)
❶	94050-06000	5	Nut-Flange (6Mm)
❶	95002-02080	1	Clip-Tube (B8)
❶	95002-50000	1	Clip-Tube (C9)

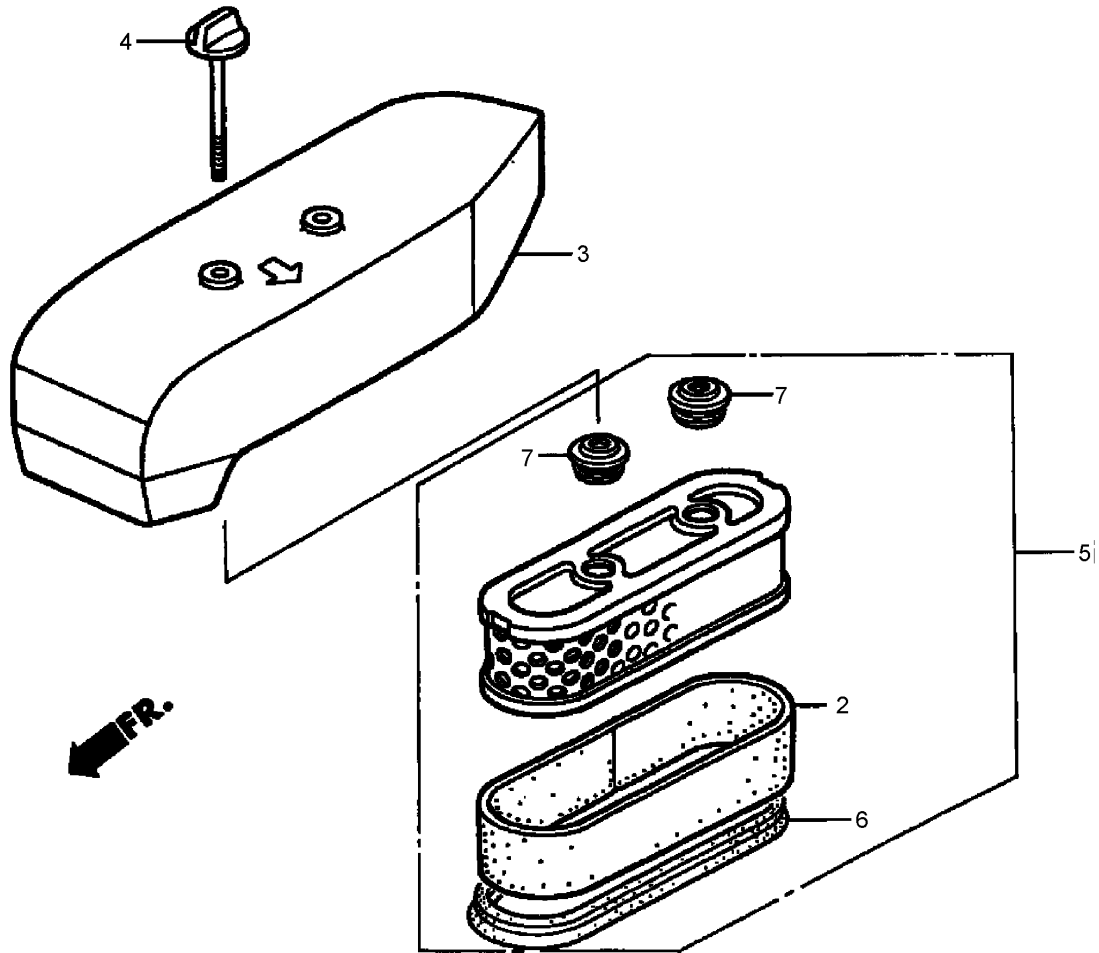

Air Cleaner Assembly Honda GXV160K1-A1T

Ref	Part No.	Qty.	Description				
②	17218-ZE7-W02	1	Filter (Outer)				
③	17231-ZE7-W00ZA	1	Cover-Cleaner, Air				
④	90004-ZE7-W00	2	Bolt-Cleaner, Air (6X73)				
⑤	17211-ZE7-W03	1	Element-Cleaner, Air				
⑥	17217-ZE7-W00	1	Gasket-Element				
⑦	17232-ZE7-W00	2	Grommet-Cleaner, Air				

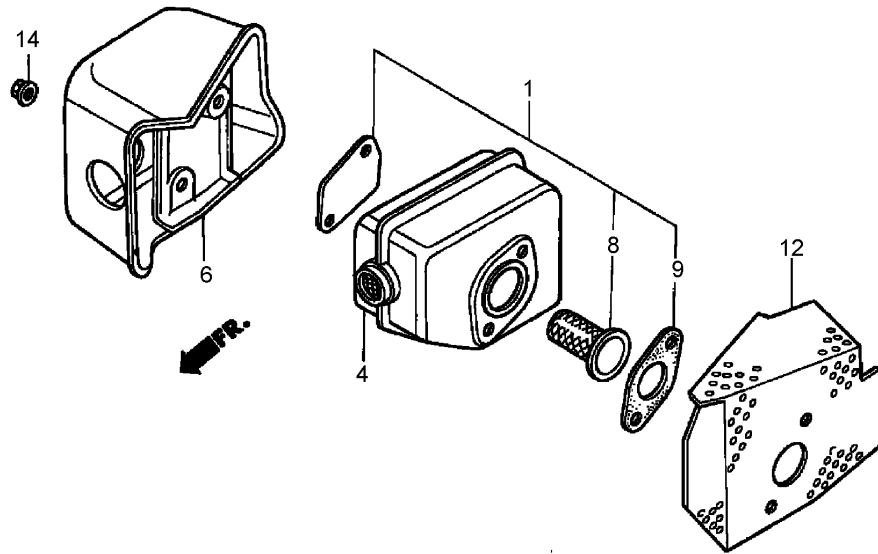

Muffler Assembly Honda GXV160K1-A1T

Ref	Part No.	Qty.	Description				
1	06180-ZE6-820	1	Spark Arrester Kit				
4	18310-ZG9-J01	1	Muffler				
6	18320-ZG9-M01	1	Protector-Muffler				
8	06180-888-505	1	Spark Arrester Kit				
8	06180-888-810	1	Spark Arrester Kit				
9	18381-ZE6-820	1	Gasket-Muffler				
12	18381-ZG9-M00	1	Gasket-Muffler				
14	90343-ZE6-000	2	Nut-Self Lock (6Mm)				

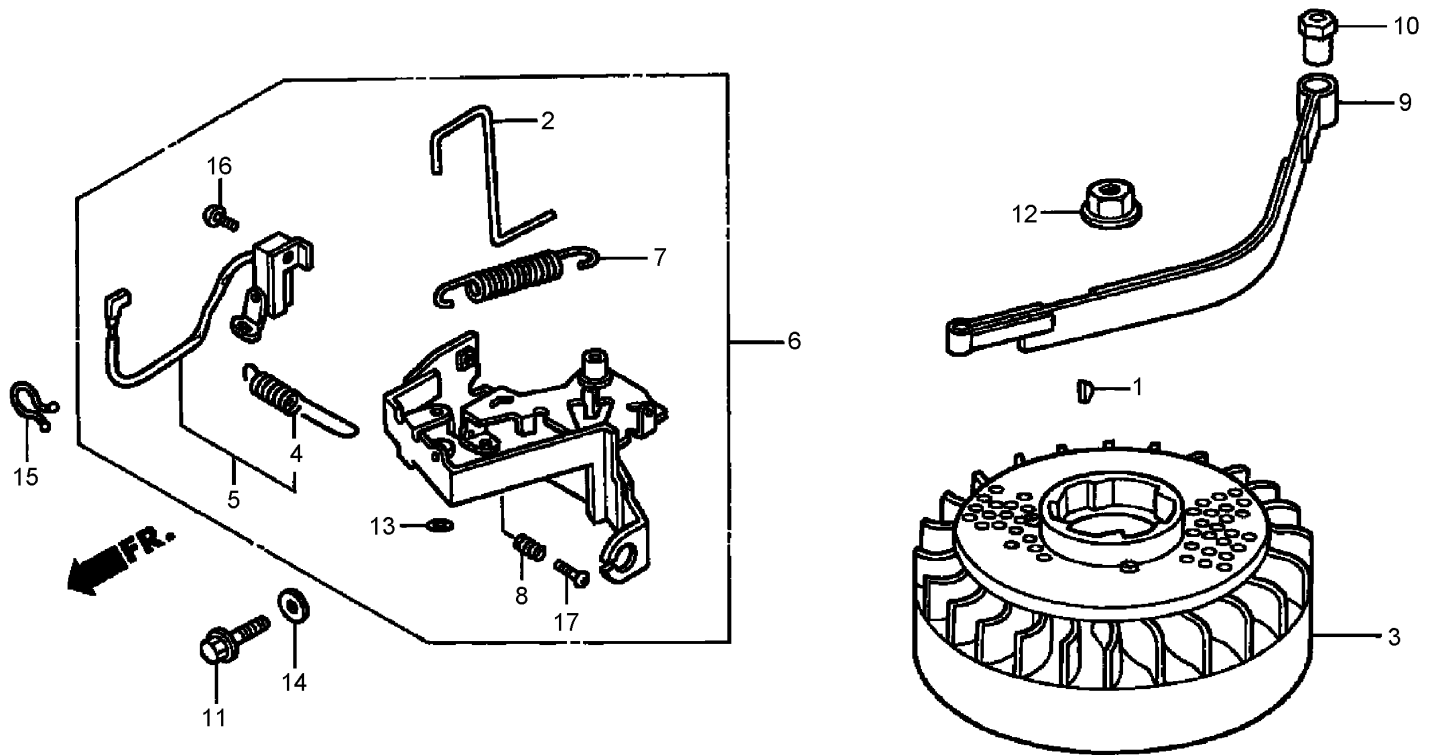

Flywheel Assembly Honda GXV160K1-A1T

Ref	Part No.	Qty.	Description
●1	13331-357-000	1	Key-Woodruff (25X18)
●2	16566-ZE7-W00	1	Rod-Governor Arm, Return
●3	31105-ZE7-W00	1	Flywheel ASM
●4	35129-ZG9-800	1	Spring-Switch, Control
●5	36100-ZE7-W01	1	Engine Stop Switch ASM
●6	75101-ZE7-W00	1	Brake Lever ASM
●7	75113-ZG9-800	1	Spring-Brake, Lever
●8	75114-ZG9-800	1	Spring-Brake, Adjusting
●9	75120-ZG9-305	1	Brake
●10	75123-ZG9-800	1	Collar-Brake, Shaft
●11	90014-952-000	1	Bolt-Flange (6X14)
●12	90201-878-003	1	Nut (14Mm)
●13	90310-ZB7-701	1	Nut-Push (2.6)

Ref	Part No.	Qty.	Description
●14	90461-357-000	1	Washer-Sealing (6.5X12)
●15	90630-ZE7-W01	1	Clip-Purse, Lock
●16	93500-04008-0A	1	Screw-Pan (4X8)
●17	93500-05012-0A	1	Screw-Pan (5X12)

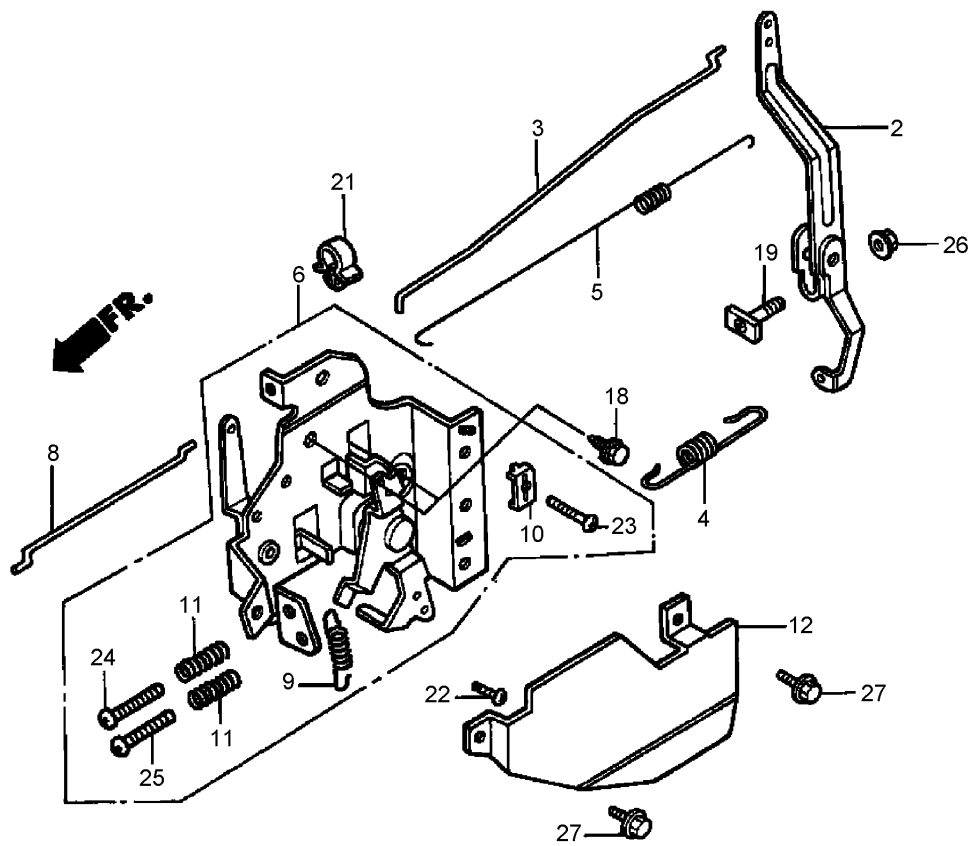

Control Assembly Honda GXV160K1-A1T

Ref	Part No.	Qty.	Description
②	16551-ZE7-000	1	Arm-Governor
③	16555-ZE7-000	1	Rod-Governor
④	16561-ZE7-020	1	Spring-Governor (STD)
⑤	16562-ZE6-000	1	Spring-Return, Throttle
⑥	16570-ZE7-020	1	Control ASM
⑧	16573-ZE7-000	1	Rod-Choke
⑨	16576-ZE7-300	1	Spring-Lever
⑩	16576-891-000	1	Holder-Cable
⑪	16584-883-300	2	Spring-Adjusting, Control
⑫	16585-ZE7-000	1	Protector-Control
⑱	90013-883-000	2	Bolt-Flange (6X12) (Ct200)
⑲	90015-ZE5-010	1	Bolt-Arm, Governor
⑳	90659-680-013	1	Clip-Harness, Wire

Ref	Part No.	Qty.	Description
⑳	93500-04008-0A	1	Screw-Pan (4X8)
㉑	93500-05016-0A	1	Screw-Pan (5X16)
㉒	93500-05020-0A	1	Screw-Pan (5X20)
㉓	93500-05028-0A	1	Screw-Pan (5X28)
㉔	94050-06000	1	Nut-Flange (6Mm)
㉕	95701-06010-00	2	Bolt-Flange (6X10)

NOTES

NOTES

NOTES

