



## Z449 Z Master<sup>®</sup> With 48in TURBO FORCE<sup>®</sup> Side Discharge Mower

Model No. 74413 - 270000001 and up.

### Parts Catalog

---

#### Ordering Replacement Parts

To order replacement parts, please supply the part number, the quantity, and the description of each part desired.

#### Understanding Reference Numbers

Each Identified part in an illustration has a reference number. The reference number for a part also appears in the parts list, along with other information about the part.

This catalog uses two special reference number formats, one to indicate parts in a service assembly and another to indicate the quantity of a given part in an illustration.

#### Service Assembly Reference Numbers

Parts in service assemblies have reference numbers in the form a:b. The a represents the reference number of the entire service assembly and the b represents a sequential number unique to each part within the service assembly.

For example, a wheel assembly might be identified by reference number 6, the tire by 6:1, the valve by 6:2, and the wheel by 6:3. When you order the assembly identified by reference number 6, you receive all parts identified by reference numbers 6:1, 6:2, and 6:3. However, you may also order any part individually. Reference numbers of this type appear in illustrations and in part lists.

#### Reference Numbers Indicating Quantity

In an illustration, if a reference number indicates more than one part, the reference number has the form nX y. The n represents the quantity of the part, the X is the multiplication symbol, and the y represents the reference number.

For example, in an illustration, the reference number 2X 37 means that two of the parts identified by reference number 37 are indicated.

# Contents

Description	Page	Description	Page
Front Frame Assembly	3	Cylinder / Crankcase Assembly Kawasaki FH580V AS29	28
Caster Wheel Assembly No. 110-5745	4	Piston / Crankshaft Assembly Kawasaki FH580V AS29	30
Height-of-Cut Assembly	5	Valve / Camshaft Assembly Kawasaki FH580V AS29	32
Main Frame Assembly	6	Lubrication Equipment Assembly Kawasaki FH580V AS29	34
Fuel System Assembly	7	Cooling Equipment Assembly Kawasaki FH580V AS29	36
Parking Brake Assembly	8	Electric Equipment Assembly Kawasaki FH580V AS29	38
Motion Control Assembly	9	Control Equipment Assembly Kawasaki FH580V AS29	40
Hydraulic System Assembly	11	Carburetor Assembly Kawasaki FH580V AS29	42
Hydraulic Pump Assembly No. 103-1942	13	Air Filter / Muffler Assembly Kawasaki FH580V AS29	44
Pump Idler and Belt Assembly	14	Starter Assembly Kawasaki FH580V AS29	46
Engine, Clutch and Muffler Assembly	15	Fuel Tank / Fuel Valve Assembly Kawasaki FH580V AS29	48
Deck Connection Assembly	16	Engine Labels Kawasaki FH580V AS29	49
Deck Assembly No. 107-3190	17	Attachments and Accessories List	50
Deck Decal Assembly No. 107-8515	19		
Spindle Assembly No. 107-8504	20		
Rubber Deflector Assembly No. 108-2792	21		
Idler Assembly	22		
Electrical System Assembly	23		
Seat and Bracket Assembly	24		
Seat Assembly No. 110-0362-19	25		
Roll-Over Protection System Assembly	26		
Roll-Over Protection System Assembly No. 107-8093	27		

## Part Description Abbreviations

Part descriptions in this catalog may include the following abbreviations.

AR. .... as required	HYD. .... hydraulic
ASM. .... assembly	LH. .... left hand
BBC. .... blade brake clutch	NI. .... nylon insert
CARR. .... carriage	NPTF. .... national pipe thread fine
DEG. .... degrees	PFH. .... phillips flat head
EXT. .... external	PPH. .... phillips pan head
FH. .... flat head	PPHTF. .... phillips pan head thread forming
GA. .... gauge	PRH. .... phillips round head
HD. .... heavy-duty	PTH. .... phillips truss head
HF. .... hex flange	PTO. .... power-take-off
HH. .... hex head	RH. .... right hand
HHF. .... hex head flange	ROPS. .... roll-over protection system
HHFTF. .... hex head flange thread forming	SFH. .... slotted fillister head
HJ. .... hex jam	SHH. .... slotted hex head
HLH. .... hex lag head	SHWH. .... slotted hex washer head
HOC. .... height-of-cut	SPH. .... slotted pan head
HSBH. .... hex socket button head	SQH. .... square head
HSFH. .... hex socket flat head	SRH. .... slotted round head
HSH. .... hex socket head	STD. .... standard
HWH. .... hex washer head	TAP. .... self tapping
HWHTF. .... hex washer head thread forming	TTH. .... torx truss head

## Footnotes

- ❶ Not serviced separately
- ❷ Obtain from your local Kawasaki dealer

- ❸ Optional Equipment

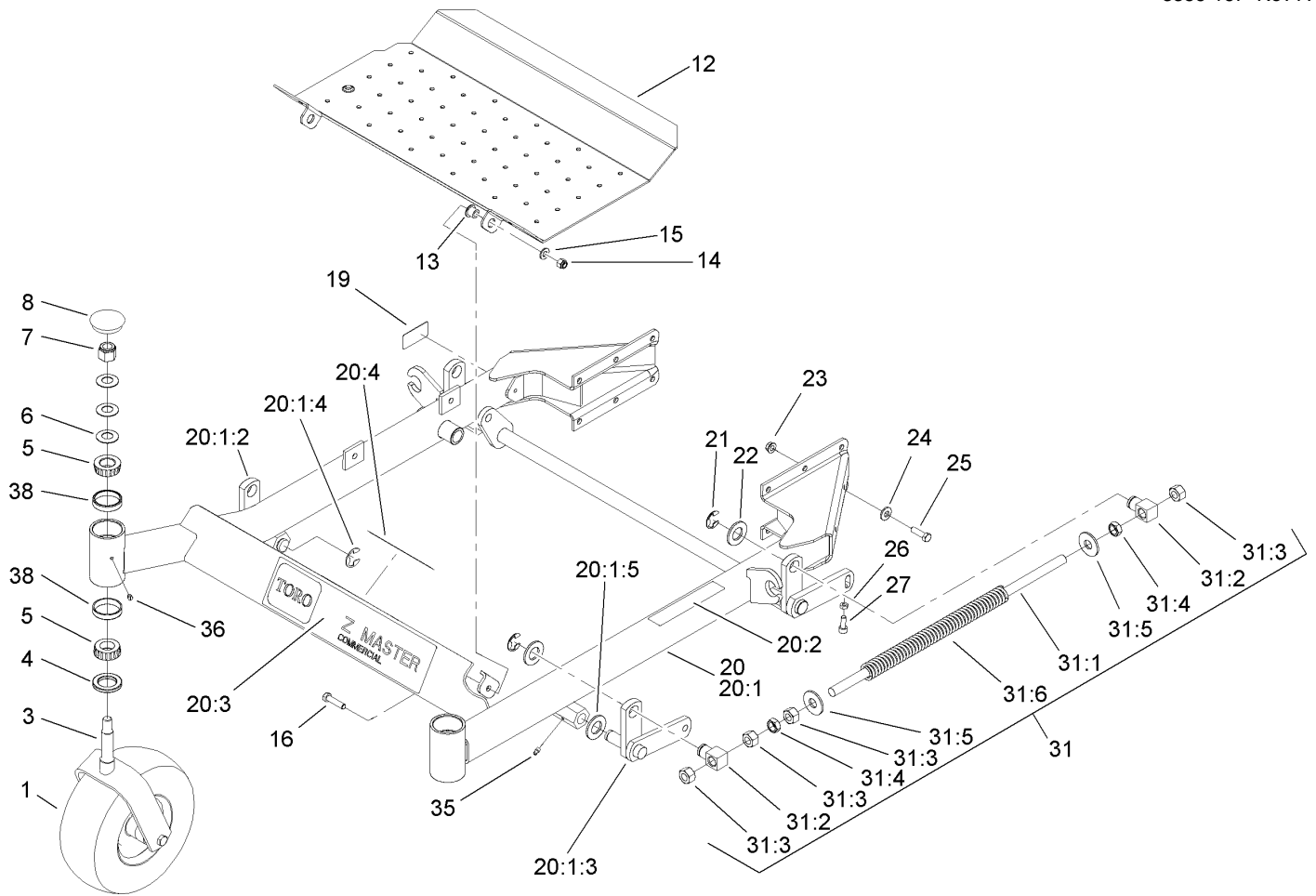

## Front Frame Assembly

Ref	Part No.	Qty.	Description
1	110-5745	2	Semi Pnuematic Wheel ASM
3	1-632511-01	2	Caster
4	1-543511	2	Seal-Grease
5	254-94	4	Bearing-Cone, Tapered
6	1-633508	6	Washer-Bellville
7	3296-51	2	Nut-Lock, NI
8	103-4882	2	Cap-Grease
12	108-5007-03	1	Floor Pan
13	86-2180	2	Bushing-Flange
14	3296-39	2	Nut-Lock, NI
15	3256-24	2	Washer-Flat
16	323-8	2	Screw-HH
19	108-5278	1	Decal
20	108-5022	1	Front Frame ASM
●20:1		1	Frame-Front
20:1:2	99-3872	1	RH Lift Arm ASM
20:1:3	99-3871	1	LH Lift Arm ASM
20:1:4	32151-103	2	Ring-Snap
20:1:5	3256-29	2	Washer-Flat
20:2	1-633818	1	Decal-Warning
20:3	106-7451	1	Decal
20:4	107-2112	1	Decal-Warning
21	32151-103	4	Ring-Snap
22	3256-29	4	Washer-Flat

Ref	Part No.	Qty.	Description
23	3290-357	12	Nut-HHF, Whiz
24	98-5975	12	Washer-Bellville
25	323-7	12	Screw-HH
26	3218-2	2	Nut-Jam
27	3274-18	2	Screw-HSH
31	1-634439	2	Front Frame Spring ASM
31:1	1-633096	1	Rod-Lift, Deck
31:2	1-633441	2	Swivel-Deck Mount, Rear
31:3	3217-11	4	Nut-Hex
31:4	3218-6	2	Nut-Jam
31:5	3256-7	2	Washer-Flat
31:6	1-633064	1	Spring-Support, Deck
35	302-19	4	Fitting-Grease
36	1-811010	2	Plug
38	254-72	4	Bearing-Cup, Tapered





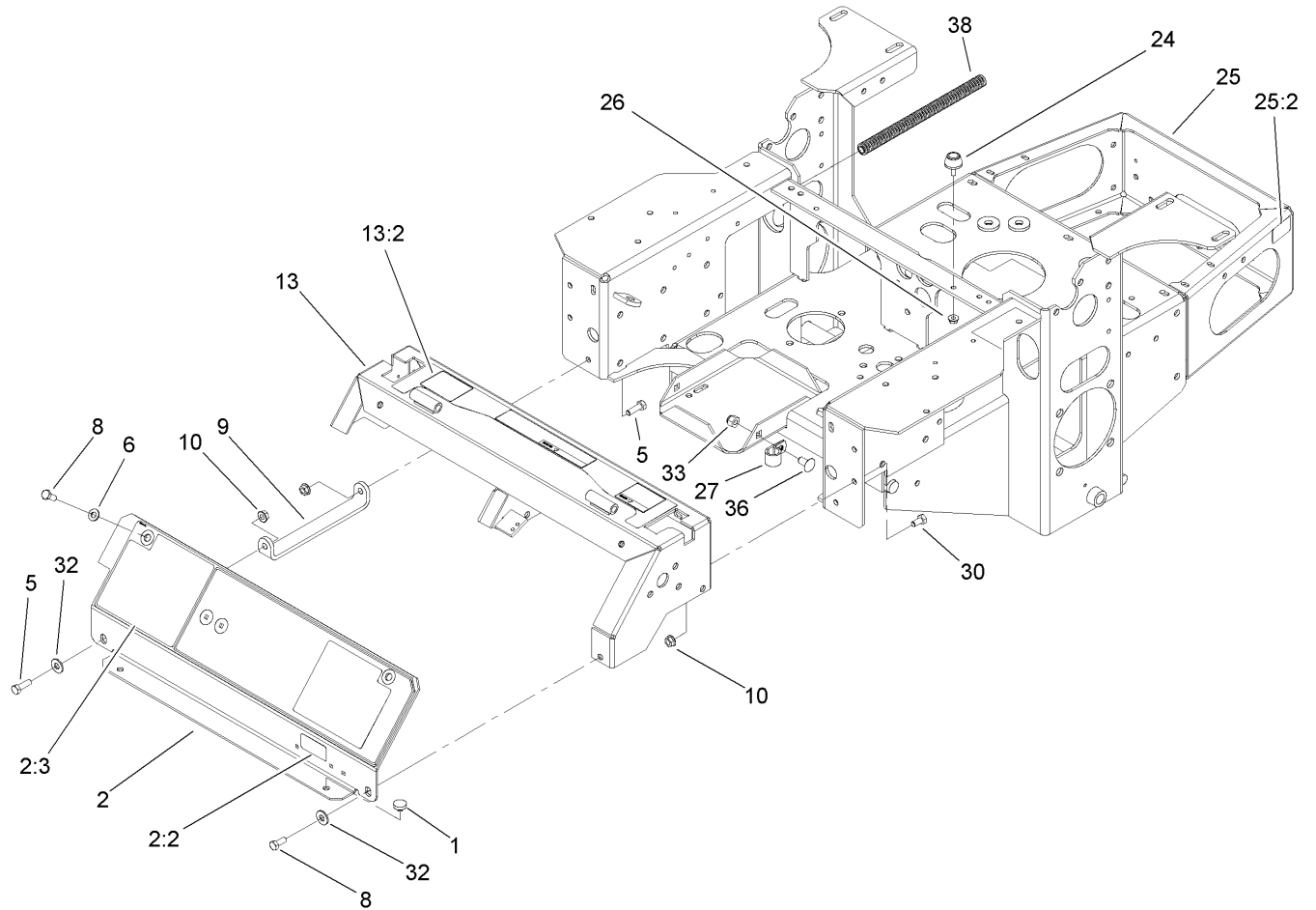

## Main Frame Assembly

Ref	Part No.	Qty.	Description
1	1-513658	2	Bumper
2	108-1864	1	Panel ASM
2:2	98-4387	1	Decal-Protection, Ear
2:3	107-8445	1	Decal-Cover, Panel
5	322-5	2	Screw-HH
6	3256-23	2	Washer-Flat
8	322-3	3	Screw-HH
9	103-7935-03	1	Bracket-Panel, Instrument
10	32128-20	6	Nut-HF
13	108-5997	1	Console ASM
13:2	108-5995	1	Decal-Warning
24	109-2365	2	Bumper-Rubber (W/Stud)
25	108-2783	1	Main Frame ASM
25:2	65-2690	2	Decal-Surface, Hot
26	32128-33	2	Nut-HF
27	1-633396	1	Clip-Loom
30	322-2	4	Screw-HH
32	3256-3	2	Washer-Flat
33	3296-39	1	Nut-Lock, NI
36	3231-21	1	Screw-CARR
38	24-7922	2	Cover-Shaft, Drive

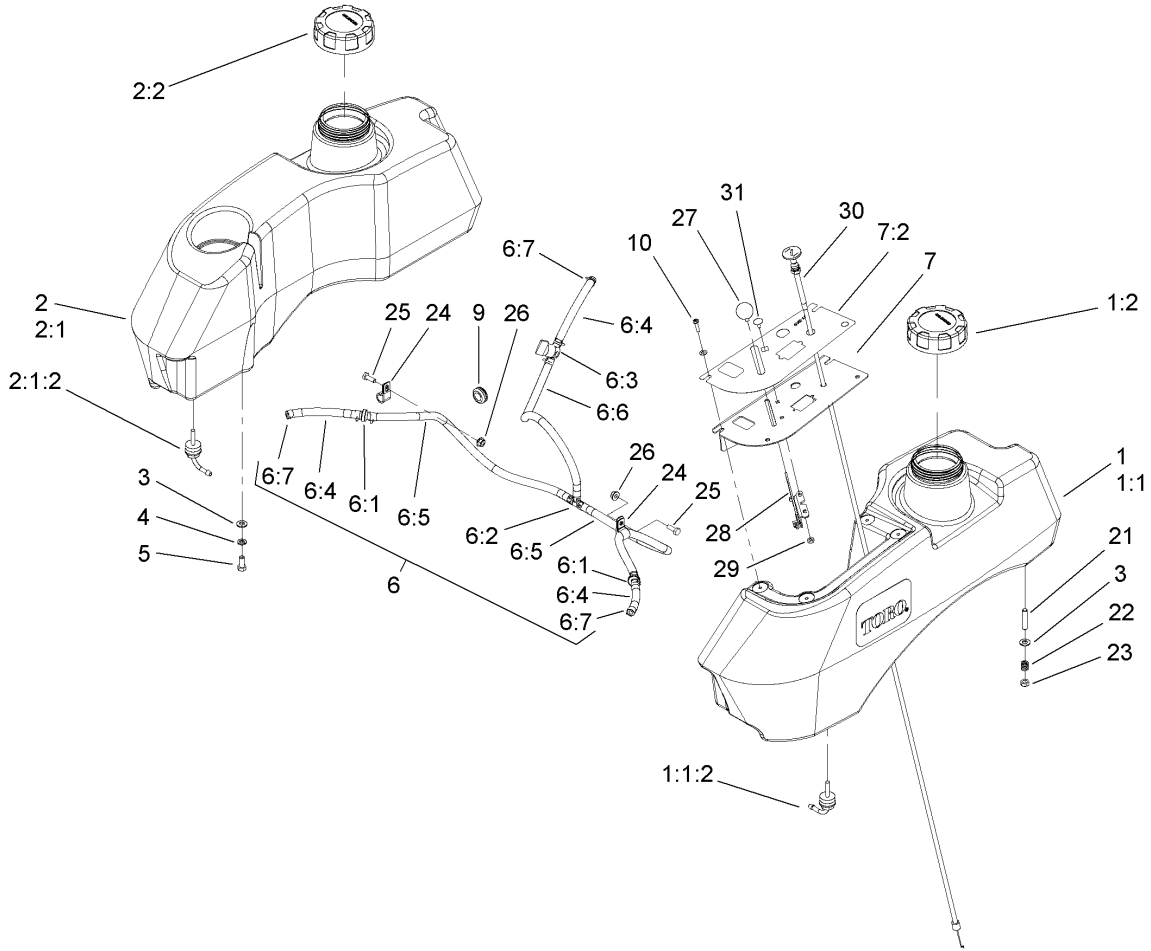
## Fuel System Assembly

Ref	Part No.	Qty.	Description
1	110-4165	1	LH Fuel Tank Service Kit
● 1:1		1	Tank-Fuel, LH
1:1:2	103-2605	1	Fitting-Fuel, Bulkhead
1:2	109-0346	1	Cap-Fuel, Gas
2	105-3639	1	RH Fuel Tank Service Kit
● 2:1		1	Tank-Fuel, RH
2:1:2	103-2605	1	Fitting-Fuel, Bulkhead
2:2	109-0346	1	Cap-Fuel, Gas
3	3256-23	8	Washer-Flat
4	1-805005	4	Washer-Lock
5	322-3	4	Screw-HH
● 6		1	Fuel Line ASM
6:1	99-5000	2	Valve-Check, Fuel
6:2	99-5005	1	Fitting-Tee, Barbed
6:3	1-603770	1	Valve-Fuel
6:4	109-0678	3	Hose-Fuel
6:5	110-5701	2	Hose-Fuel
6:6	109-0297	1	Hose-Fuel
6:7	1-303077	12	Clamp
7	107-2149	1	Control Panel ASM
7:2	110-0439	1	Decal-Panel, Control
9	1-543296	2	Grommet
10	1-803071	4	Screw
21	1-633023	4	Stud

Ref	Part No.	Qty.	Description
22	1-633349	4	Spring-Tank, Fuel
23	3296-47	4	Nut-Lock, NI
24	1-513762	2	Clip-Loom
25	321-4	2	Screw-HH
26	32128-33	2	Nut-HF
27	1-513592	1	Knob-Ball
28	1-633696	1	Throttle Cable ASM
29	3296-2	2	Nut-Lock
30	106-9962	1	Control-Choke, Push / Pull
31	1-807513	2	Bolt-CARR

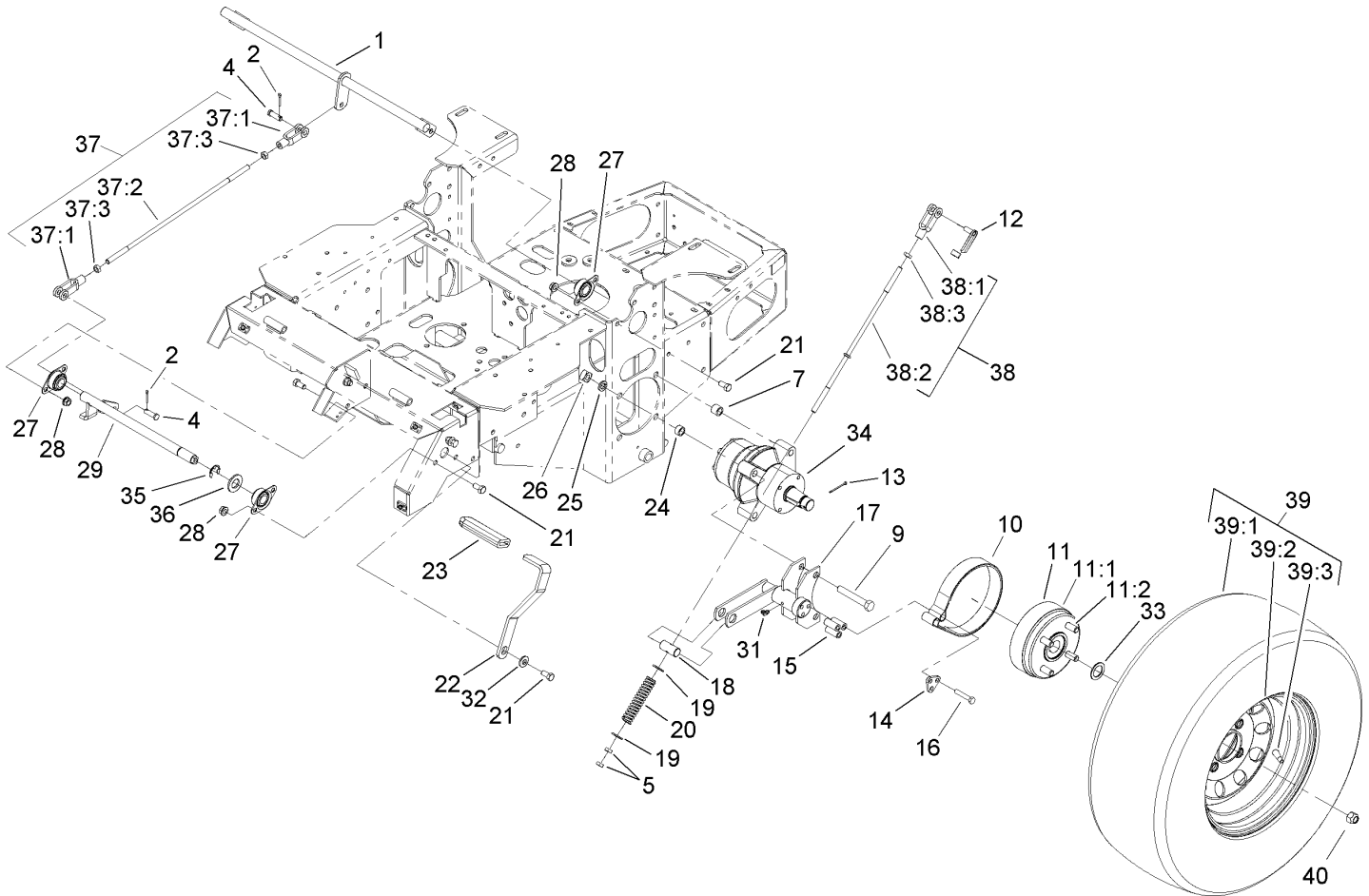

## Parking Brake Assembly

Ref	Part No.	Qty.	Description
1	1-652073-03	1	Crank-Brake, Park
2	3272-10	2	Pin-Cotter
4	1-808285	2	Pin-Clevis
5	3219-3	4	Nut-Hex
7	1-653068	4	Spacer-Wheel
9	325-13	8	Screw-HH
10	103-0355	2	Band-Brake
11	103-0590	2	Hub And Wheel ASM
11:1	103-0589	1	Wheel Hub ASM
11:2	1-633926	4	Stud-Wheel
12	103-2399	2	Pin-Spring, Clevis
13	1-806800	2	Pin-Cotter
14	103-0374	2	Retainer-Band, Brake
15	103-0384	6	Spacer
16	322-9	6	Screw-HH
17	103-0352-03	2	Bracket-Brake
18	1-633144	2	Pin-Trunion
19	3256-4	4	Washer-Flat
20	1-633454	2	Spring-Brake
21	323-4	9	Screw-HH
22	1-653074-03	1	Handle-Brake, Park
23	1-633268	1	Grip-Lever, Brake
24	1-653069	4	Spacer-Wheel
25	3253-7	8	Washer-Lock

Ref	Part No.	Qty.	Description
26	103-0131	8	Nut-Square
27	1-633102	4	Bearing-Flange, Side
28	3290-357	8	Nut-HHF, Whiz
29	103-3116	1	Shaft-Brake, Parking
31	1481	2	Fitting-Grease
32	98-5975	1	Washer-Belleville
33	1-523157	2	Washer-Spacer, 14 GA
34	103-5333	2	Motor-Wheel
35	32151-48	1	E-Ring
36	3256-28	1	Washer-Flat
37	103-4328	1	Brake Rod ASM
37:1	1-633131	2	Yoke-Linkage, Brake
37:2	1-653061	1	Linkage-Handle, Brake
37:3	3219-3	2	Nut-Hex
38	103-4329	2	Brake Rod ASM
38:1	1-633131	1	Yoke-Linkage, Brake
38:2	103-0356	1	Rod-Brake
38:3	3219-3	1	Nut-Hex
39	1-653159	2	Wheel And Tire ASM
39:1	1-653160	1	Tire
39:2	1-653161	1	Wheel
39:3	232-27	1	Stem-Valve
40	242-50	8	Nut-Lug

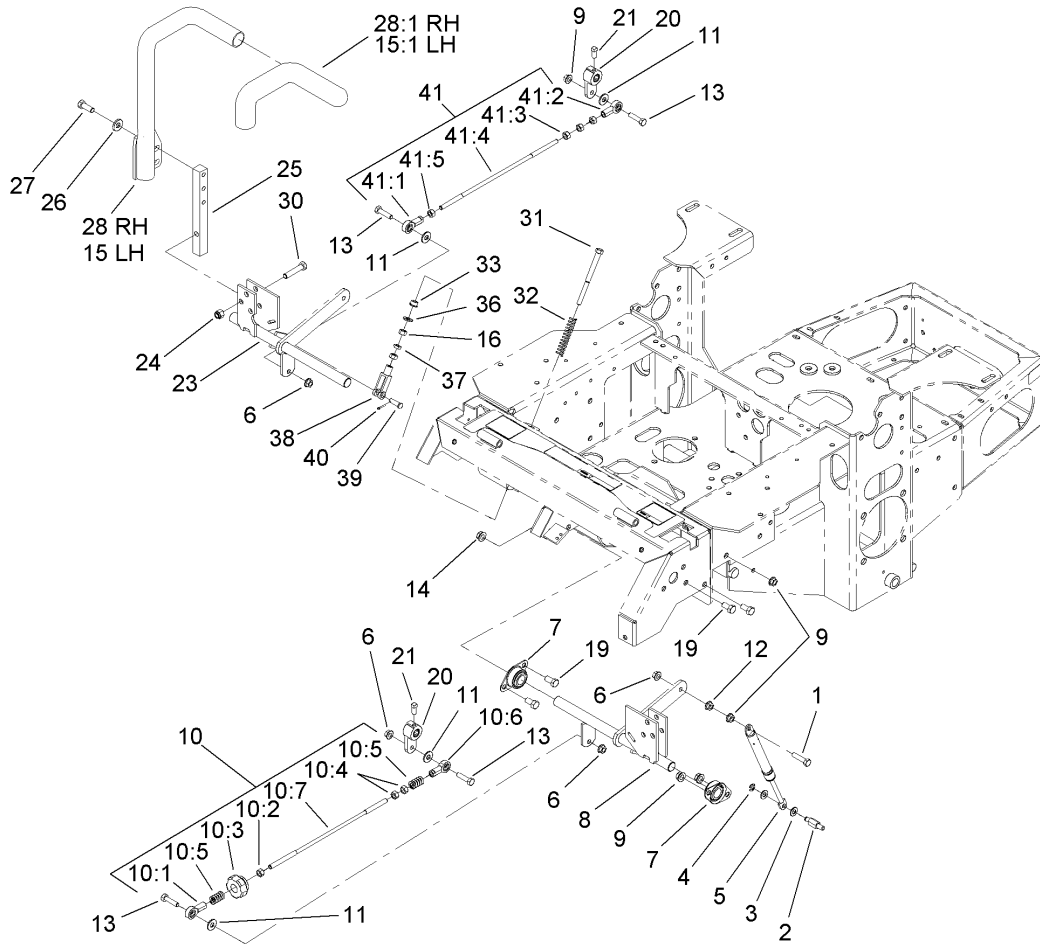

## Motion Control Assembly

Ref	Part No.	Qty.	Description
1	1-403180	2	Screw-HH
2	103-4101	2	Pin-Damper
3	3256-23	4	Washer-Flat
4	32120-35	2	E-Ring
5	109-2339	2	Damper-Control, Motion
6	3296-29	6	Nut-Lock, NI
7	1-633102	4	Bearing-Flange, Side
8	103-4774	1	Control-Motion, LH
9	32128-20	8	Nut-HF
10	103-4326	1	Tracking Rod ASM
10:1	1-543017	1	Balljoint-RH
10:2	3219-2	1	Nut-Hex
10:3	103-3060	1	Knob-Tracking
10:4	1-804524	2	Nut
10:5	1-323245	2	Spring-Compression
10:6	1-633152	1	Balljoint-Thread, LH
10:7	103-3066	1	Link-Rod, Tracking
11	3256-3	4	Washer-Flat
12	3217-6	2	Nut-Hex
13	322-6	4	Screw-HH
14	3290-357	6	Nut-HHF, Whiz
15	108-7238	1	LH Lever ASM
15:1	106-9987	1	Grip-Control, Motion
16	3219-2	4	Nut-Hex

Ref	Part No.	Qty.	Description
19	323-4	6	Screw-HH
20	103-3717	2	Arm-Control
21	1-803022	2	Screw-Set
23	103-4773	1	Control-Motion, RH
24	3296-39	6	Nut-Lock, NI
25	103-0407	2	Arm-Shaft, Control
26	98-5975	4	Washer-Belleveille
27	323-6	4	Screw-HH
28	108-7237	1	RH Lever ASM
28:1	106-9987	1	Grip-Control, Motion
30	323-9	6	Screw-HH
31	1-603737	2	Bolt-Return, Neutral
32	1-603807	2	Spring-Return, Neutral
33	1-603735	2	Bushing-Flanged
36	3256-2	2	Washer-Flat
37	3220-2	2	Nut-Jam
38	1-303105	2	Yoke-Adjustable
39	1-808280	2	Pin-Clevis
40	3272-5	2	Pin-Cotter
41	103-4327	1	Tracking ASM
41:1	1-543017	1	Balljoint-RH
41:2	1-633152	1	Balljoint-Thread, LH
41:3	1-804524	1	Nut
41:4	103-3066	1	Link-Rod, Tracking



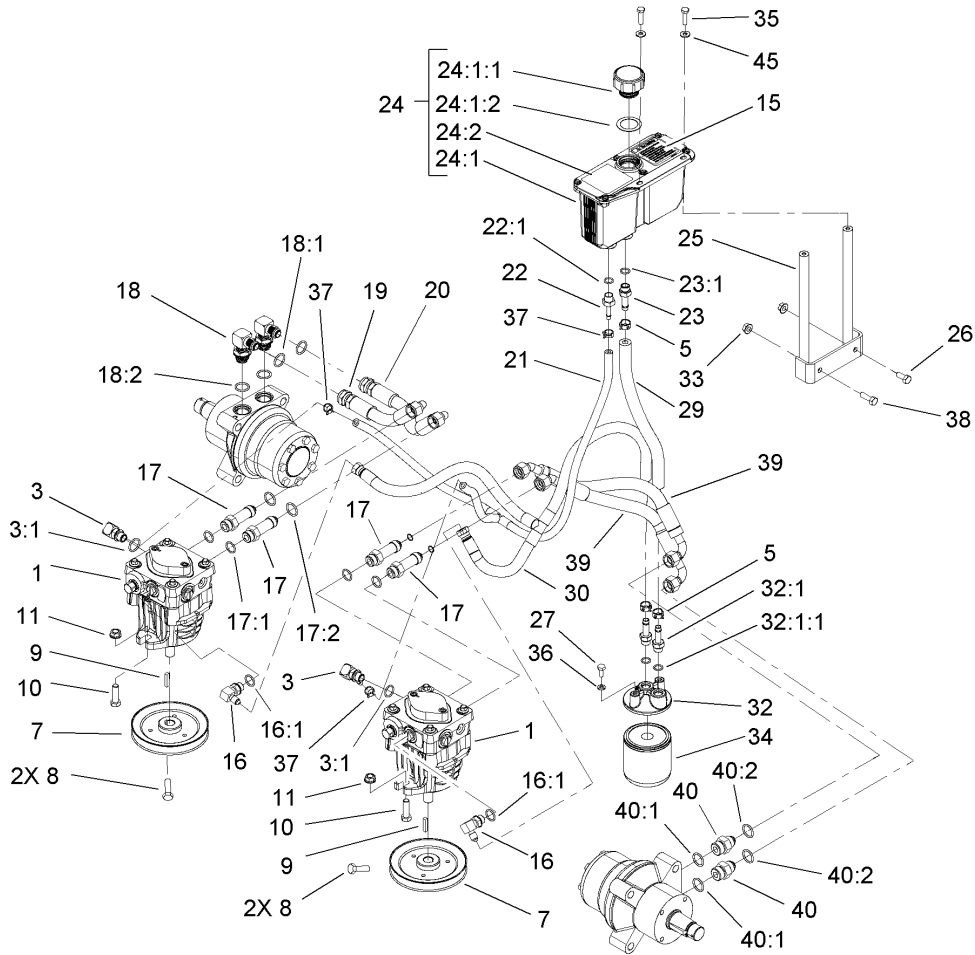

## Hydraulic System Assembly

Ref	Part No.	Qty.	Description
1	103-1942	2	Pump-HYD
3	103-1799	2	Elbow-90 DEG
3:1	237-42	1	O-Ring
5	103-1988	3	Clamp-Hose
7	1-653156	2	Pulley
8	1-803050	4	Screw-Set
9	1-807272	2	Key
10	323-7	4	Screw-HH
11	3290-357	4	Nut-HHF, Whiz
15	103-2644	1	Decal-Exhaust
16	103-1802	2	Fitting-HYD, 90 DEG
16:1	1-603921	1	O-Ring
17	103-1940	4	Adapter-HYD, Straight
17:1	237-79	1	O-Ring
17:2	1-603992	1	O-Ring
18	1-633605	2	Fitting-HYD, 90 DEG
18:1	1-603992	1	O-Ring
18:2	237-80	1	O-Ring
19	1-653186	1	Hose-Front
20	1-653187	1	Hose-Rear, RH
21	103-2357	1	HYD Hose ASM
22	103-1801	1	Adapter-Straight
22:1	237-42	1	O-Ring
23	103-1912	1	Adapter-Straight

Ref	Part No.	Qty.	Description
23:1	237-42	1	O-Ring
24	103-1947	1	HYD Reservoir ASM
24:1		1	Reservoir-HYD
24:1:1	103-1948	1	Cap-Reservoir, HYD
24:1:2	103-1949	1	Gasket-Cap
24:2	1-523552	1	Decal-Tank, HYD
25	103-3071-03	1	Stand-Reservoir
26	322-3	1	Screw-HH
27	321-3	2	Screw-HH
29	103-3077	1	HYD Hose ASM
30	103-2930	1	HYD Hose ASM
32	103-2889	1	Filter Head ASM
32:1	103-1912	2	Adapter-Straight
32:1:1	237-42	1	O-Ring
33	32128-20	2	Nut-HF
34	1-633750	1	Filter-Oil, HYD
34	1-633752	1	Filter-HYD, Winter
35	321-6	2	Screw-HH
36	1-805004	2	Washer-Lock
37	103-1716	3	Clamp-Hose
38	322-5	1	Screw-HH
39	103-3809	2	Hose-LH
40	1-603991	2	Fitting-Straight
40:1	237-80	1	O-Ring





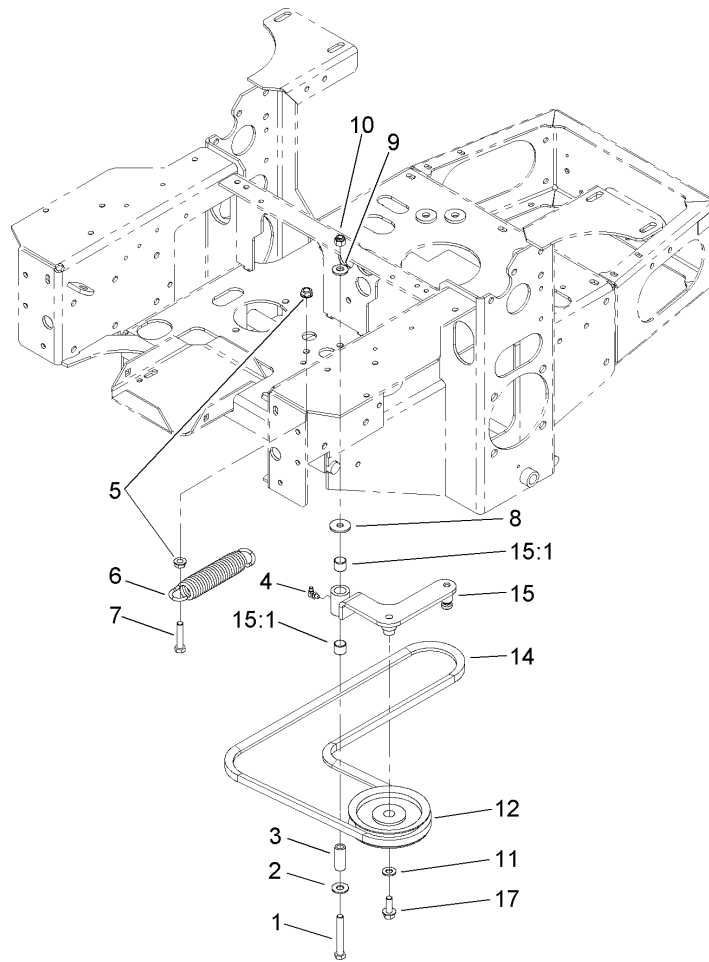

### Pump Idler and Belt Assembly

Ref	Part No.	Qty.	Description
1	323-13	1	Screw-HH
2	3256-4	1	Washer-Flat
3	1-603044	1	Bushing
4	302-40	1	Fitting-Grease
5	3290-357	2	Nut-HHF, Whiz
6	103-4480	1	Spring-Extension
7	323-9	1	Screw-HH
8	63-8410	1	Washer
9	98-5975	1	Washer-Belleville
10	3296-39	1	Nut-Lock, NI
11	3256-24	1	Washer-Flat
12	1-603843	1	Pulley-Idler
14	107-3960	1	Belt
15	103-4482	1	Idler Arm ASM
15:1	103-4681	2	Sleeve-Bearing
17	3234-11	1	Screw-HHF

--	--	--	--

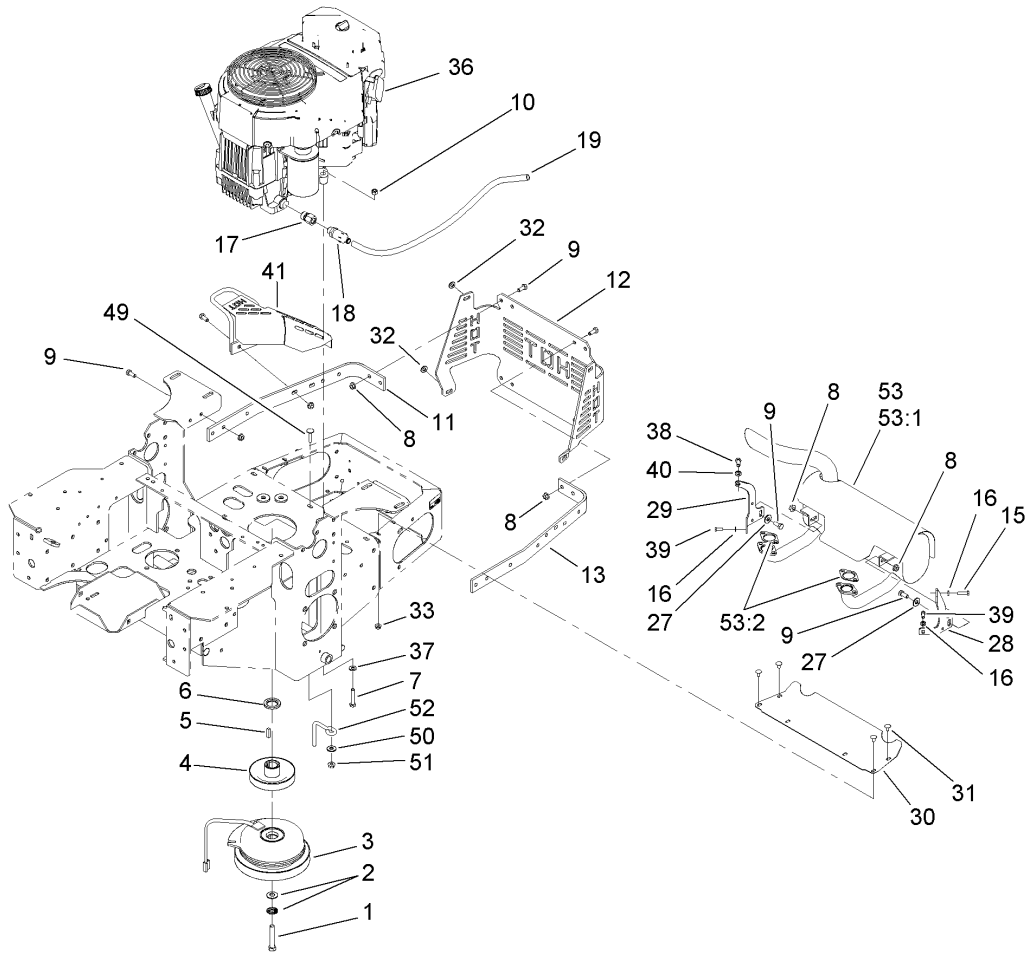

## Engine, Clutch and Muffler Assembly

Ref	Part No.	Qty.	Description
1	3212-12	1	Screw-HH
2	1-603610	2	Washer-Spring
3	109-2916	1	Clutch, Warner Electric
4	103-3913	1	Pulley
5	1-807259	1	Key
6	103-2308	1	Spacer-Crankshaft
7	322-9	4	Screw-HH
8	32128-20	33	Nut-HF
9	322-3	25	Screw-HH
10	3296-29	4	Nut-Lock, NI
11	103-3078-03	1	Strap-Guard, RH
12	103-3219-03	1	Guard-Rear
13	103-3164-03	1	Strap-Guard, LH
15	33113-025	1	Screw-HH
16	1-805004	3	Washer-Lock
17	103-1966	1	Adapter
18	92-6877	1	Valve-Drain, Oil
19	106-7022	1	Tube-Drain, Oil
27	3256-3	3	Washer-Flat
28	109-3476-03	1	Bracket-Muffler, LH
29	109-3477-03	1	Bracket-Muffler, RH
30	103-2740-03	1	Deflector-Short
31	3229-10	4	Screw-CARR
32	3256-23	4	Washer-Flat

Ref	Part No.	Qty.	Description
33	32128-33	4	Nut-HF
① 36		1	Engine-Kawasaki, FH580V-As29
37	1-303334	4	Washer-Spring
38	33114-025	1	Screw-HH
39	33113-016	2	Screw-HH
40	1-805005	1	Washer-Lock
41	103-3218-03	1	Guard-Tailpipe
49	3230-3	1	Screw-CARR
50	3256-3	1	Washer-Flat
51	32128-20	1	Nut-HF
52	108-1058	1	Rod-Belt
53	103-4483	1	Muffler Kit
53:1	103-4476	1	Muffler
53:2	1-653290	2	Gasket

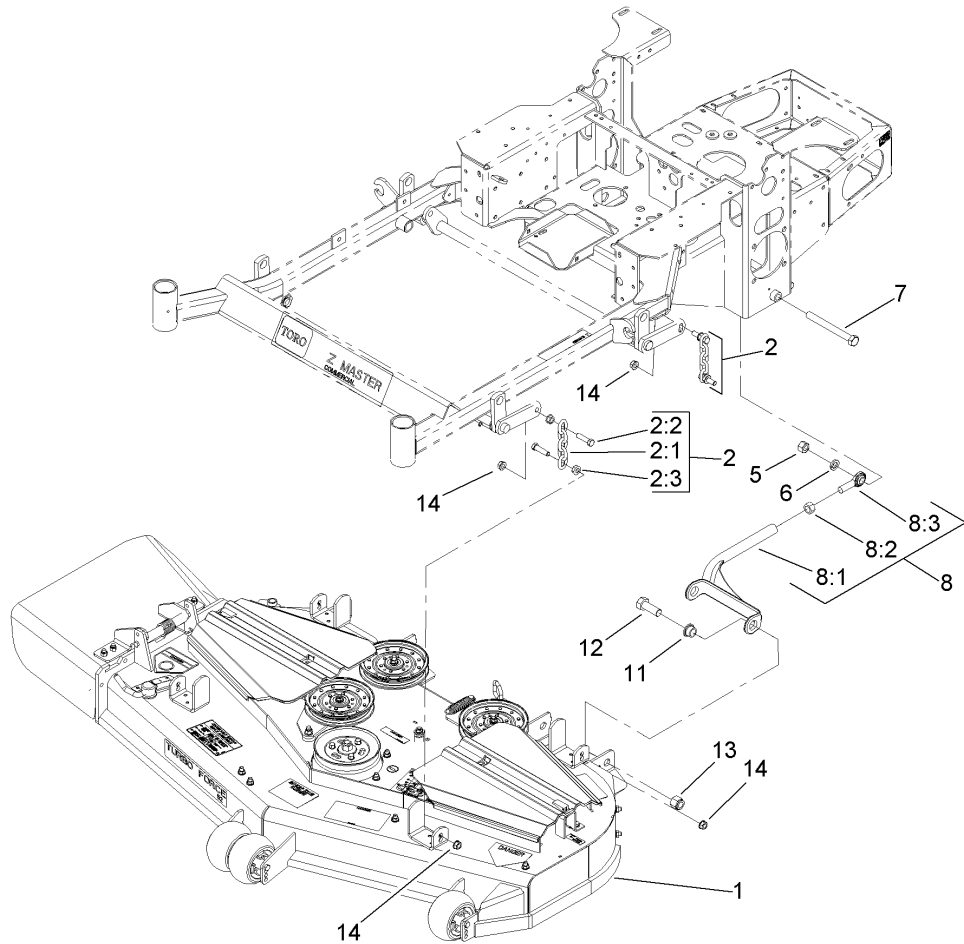

## Deck Connection Assembly

Ref	Part No.	Qty.	Description
1	107-3190	1	Deck ASM
2	103-9792	4	Deck Chain ASM
2:1	1-633447	1	Chain-Lift, Deck
2:2	103-1898	2	Screw-HH
2:3	32128-37	2	Nut-HF
5	3217-11	2	Nut-Hex
6	3253-8	2	Washer-Lock
7	1-800344	2	Screw
8	108-7768	2	Strut ASM
8:1	108-7753-03	1	Strut-Deck, Machined
8:2	3219-6	1	Nut-Hex
8:3	1-633029	1	Balljoint-Spherical
11	93-2877	4	Bushing
12	328-24	4	Screw-HH
13	3296-51	4	Nut-Lock, NI
14	32128-37	8	Nut-HF

--	--	--	--

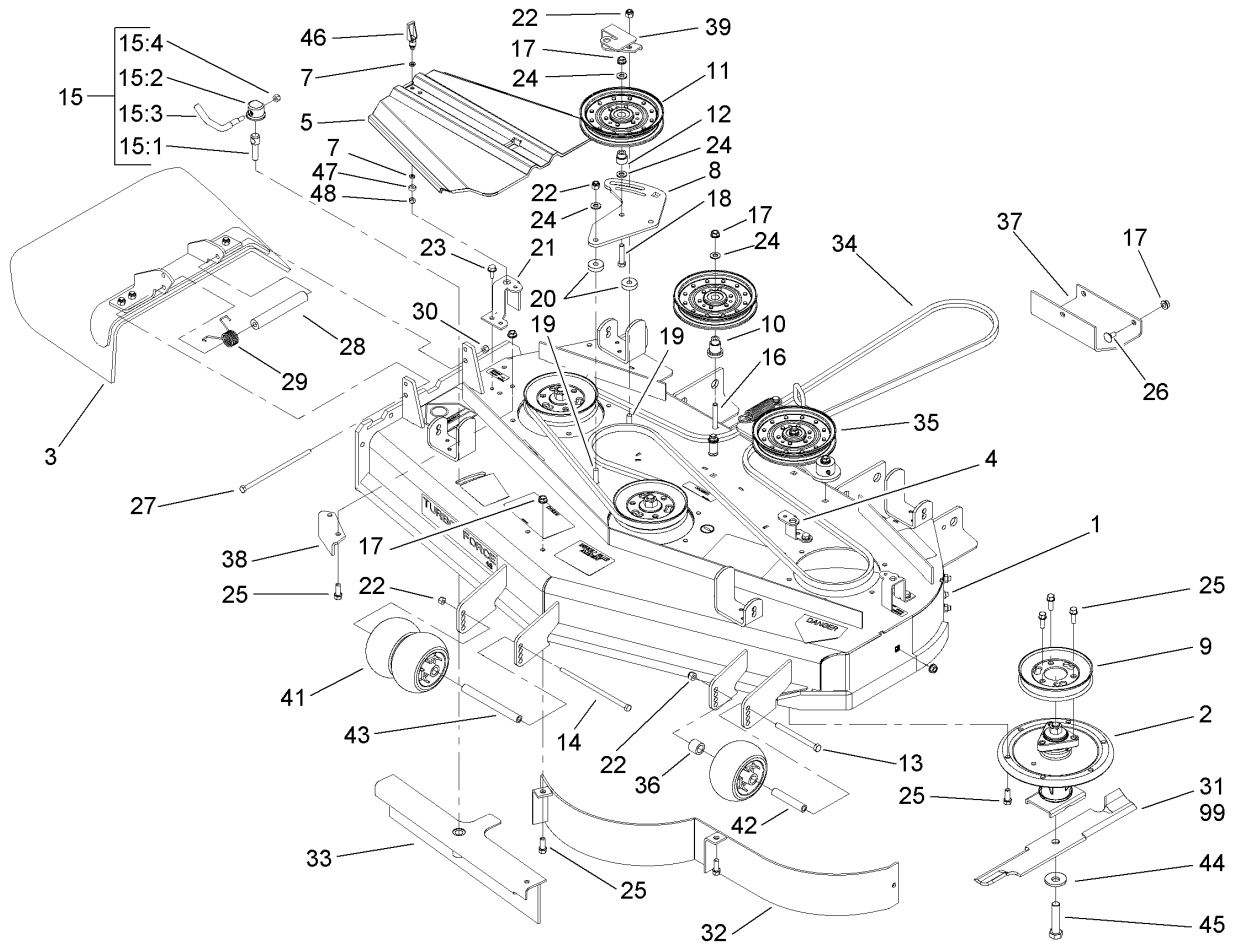

## Deck Assembly No. 107-3190

Ref	Part No.	Qty.	Description
1	107-8515	1	Deck ASM
2	107-8504	3	Spindle ASM
3	108-2792	1	Rubber Deflector ASM
4	108-2177-01	1	Bracket-Cover, Tall
5	107-8536	2	Cover-Belt
7	99-3058	2	Washer
8	107-8516-01	1	Plate-Idler
9	107-1684	3	Pulley
10	106-3214	1	Mount-Pulley
11	1-633109	2	Idler-Flat
12	1-603496	1	Bushing-Idler
13	323-23	1	Screw-HH
14	323-28	1	Screw-HH
15	107-1664	1	Lever ASM
15:1	106-3239	1	Screw-Lock
15:2	107-1644	1	Cap-Lock
15:3	106-3241	1	Lever-Lock
15:4	3296-29	1	Nut-Lock, NI
16	3231-31	1	Screw-CARR
17	3290-357	32	Nut-HHF, Whiz
18	323-9	1	Screw-HH
19	3231-4	2	Screw-CARR
20	105-7788	2	Spacer
21	108-4121-01	2	Bracket-Cover

Ref	Part No.	Qty.	Description
22	3296-39	4	Nut-Lock, NI
23	32144-70	3	Screw-HWHTF
24	3256-24	4	Washer-Flat
25	92-1624	32	Screw
26	3231-1	7	Screw-CARR
27	322-50	1	Screw-HH
28	105-4622	1	Spacer
29	108-4052	1	Spring-Torsion
30	3296-29	1	Nut-Lock, NI
31	107-3192-03	3	Blade-Rotary, 16.5 Inch (High Flow)
32	107-8510-01	1	Baffle ASM
33	107-8506-01	1	Baffle ASM
34	106-7369	1	Belt-V
35		1	Spring Idler ASM
36	98-7913	1	Tube-Spacer
37	107-3166-01	1	Skid
38	107-8541-01	1	Baffle-Discharge
39	108-2228-01	1	Bracket-Cover
41	1-603299	3	Roller-Scalp, Anti
42	98-7912	1	Tube-Spacer
43	98-5967	1	Spacer-Wheel
44	103-0865	3	Washer-Blade Bolt, Heavy
45	103-0862	3	Screw-Cap



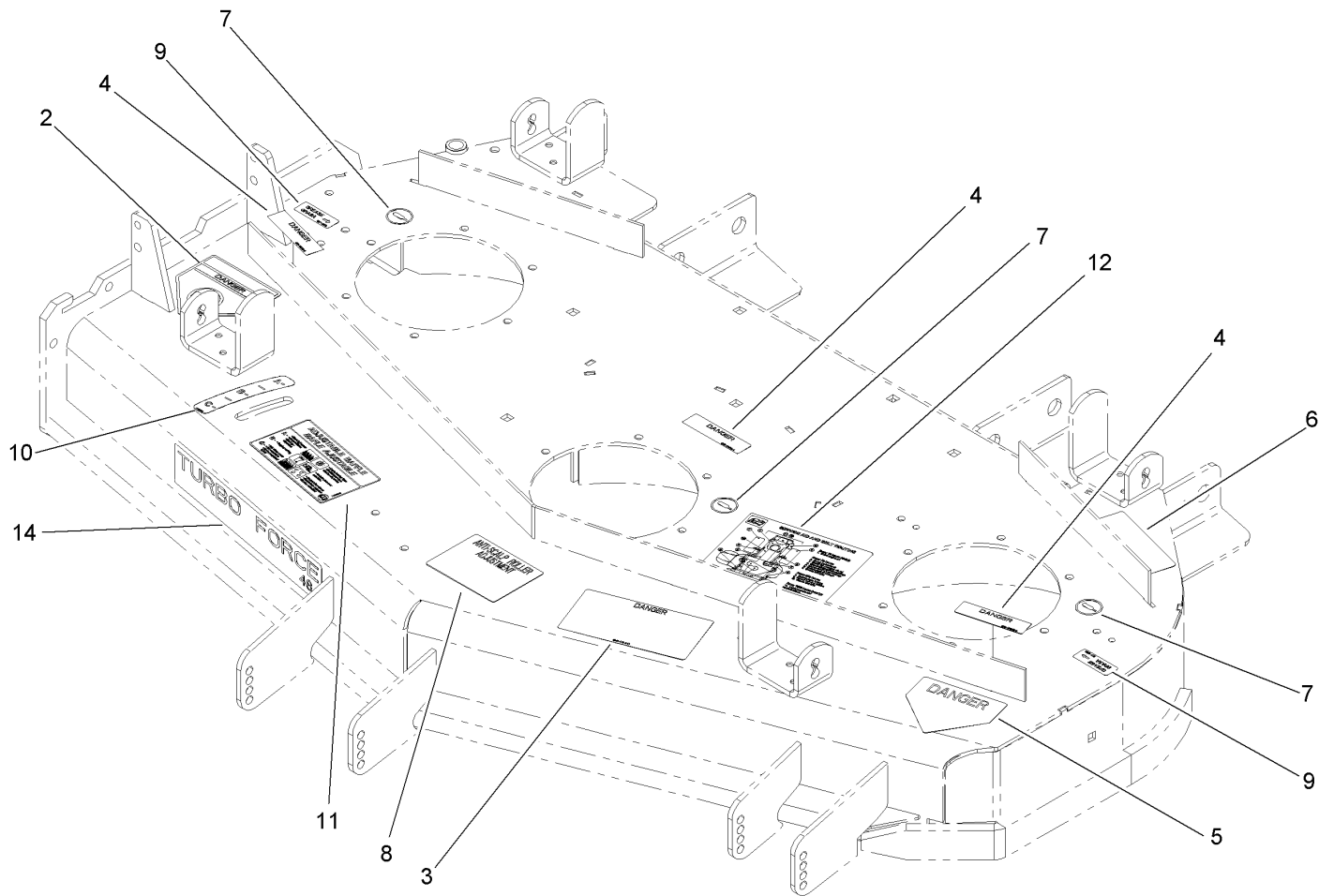

## Deck Decal Assembly No. 107-8515

Ref	Part No.	Qty.	Description
2	54-9220	1	Decal-Danger
3	66-1340	1	Decal-Danger
4	98-5954	3	Decal-Cover, Missing
5	1-403005	1	Decal-Danger
6	68-8340	1	Decal-Torque
7	58-6520	3	Decal-Grease
8	105-7798	1	Decal-Scalp, Anti
9	107-1613	2	Decal-Grease
10	110-2067	1	Decal-Setting, Baffle
11	110-2068	1	Decal-Adjustment, Baffle
12	107-1687	1	Decal-Aid, Service
14	107-1690	1	Decal

--	--	--	--



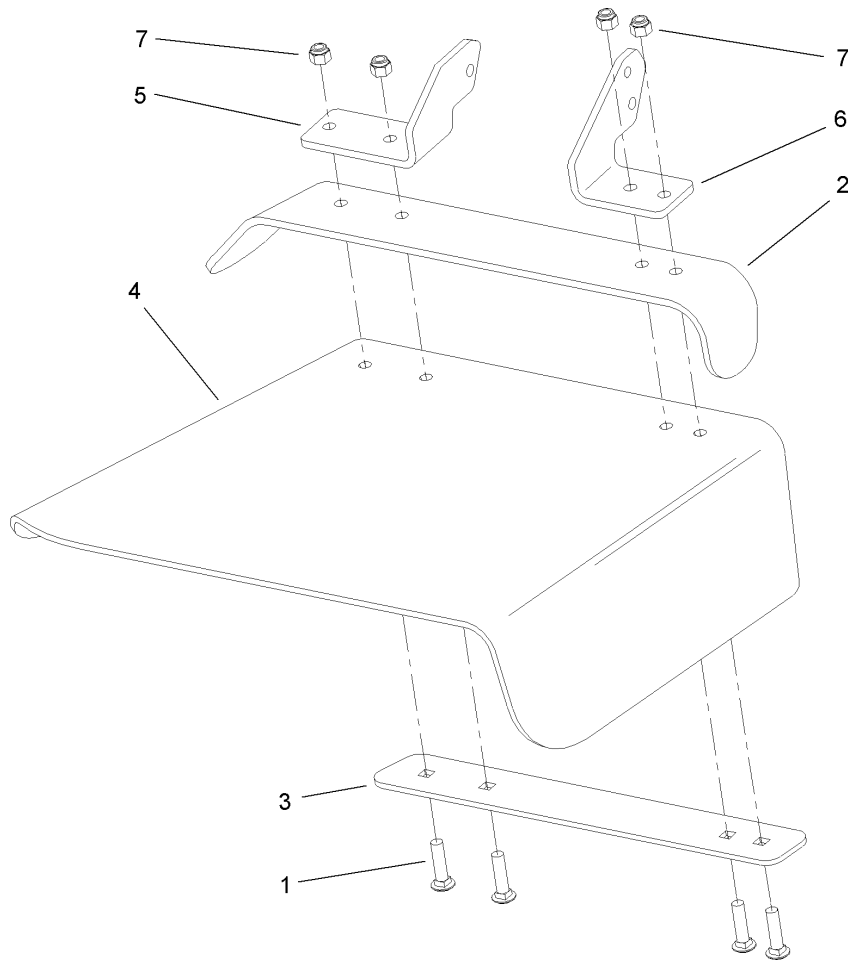

### Rubber Deflector Assembly No. 108-2792

Ref	Part No.	Qty.	Description
1	3231-4	4	Screw-CARR
2	106-3246-01	1	Deflector
3	106-3248-03	1	Strap-Discharge
4	108-5029	1	Deflector-Rubber
5	108-4059-01	1	Plate-Hinge, Rear
6	106-3253-01	1	Plate-Hinge, Front
7	3296-39	4	Nut-Lock, NI

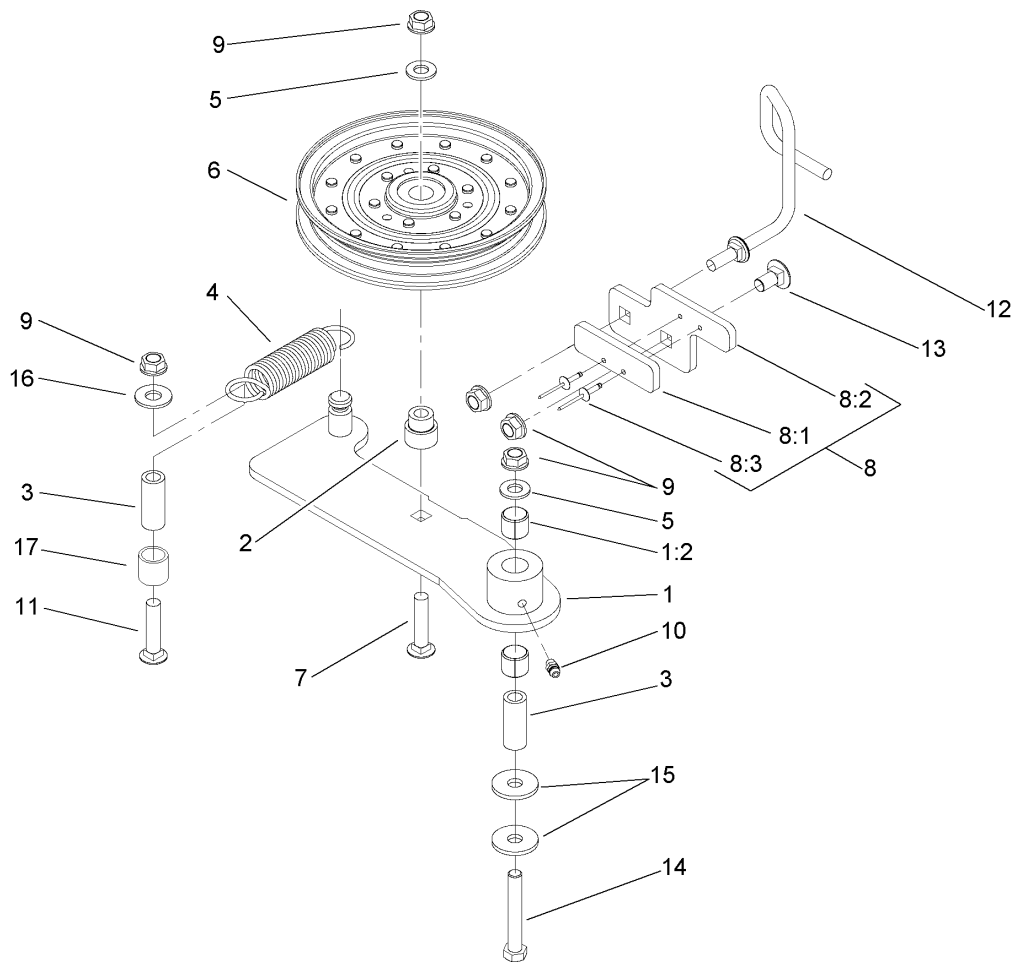

## Idler Assembly

Ref	Part No.	Qty.	Description
1	108-4062	1	Idler Arm ASM
1:2	103-4681	2	Sleeve-Bearing
2	1-603496	1	Bushing-Idler
3	1-603044	2	Bushing
4	108-4056	1	Spring-Extension
5	3256-24	2	Washer-Flat
6	1-633109	1	Idler-Flat
7	3231-6	1	Screw-CARR
8		1	Stop Pad ASM
8:1	106-3229	1	Pad-Bumper
8:2	107-1697-01	1	Plate-Stop
8:3	3269-24	2	Rivet
9	3290-357	5	Nut-HHF, Whiz
10	302-5	1	Fitting-Grease
11	3231-31	1	Screw-CARR
12	108-4072	1	Guide-Belt
13	3231-1	1	Screw-CARR
14	323-12	1	Screw-HH
15	2844	2	Washer
16	3256-4	1	Washer-Flat
17	108-4063	1	Spacer-Rubber

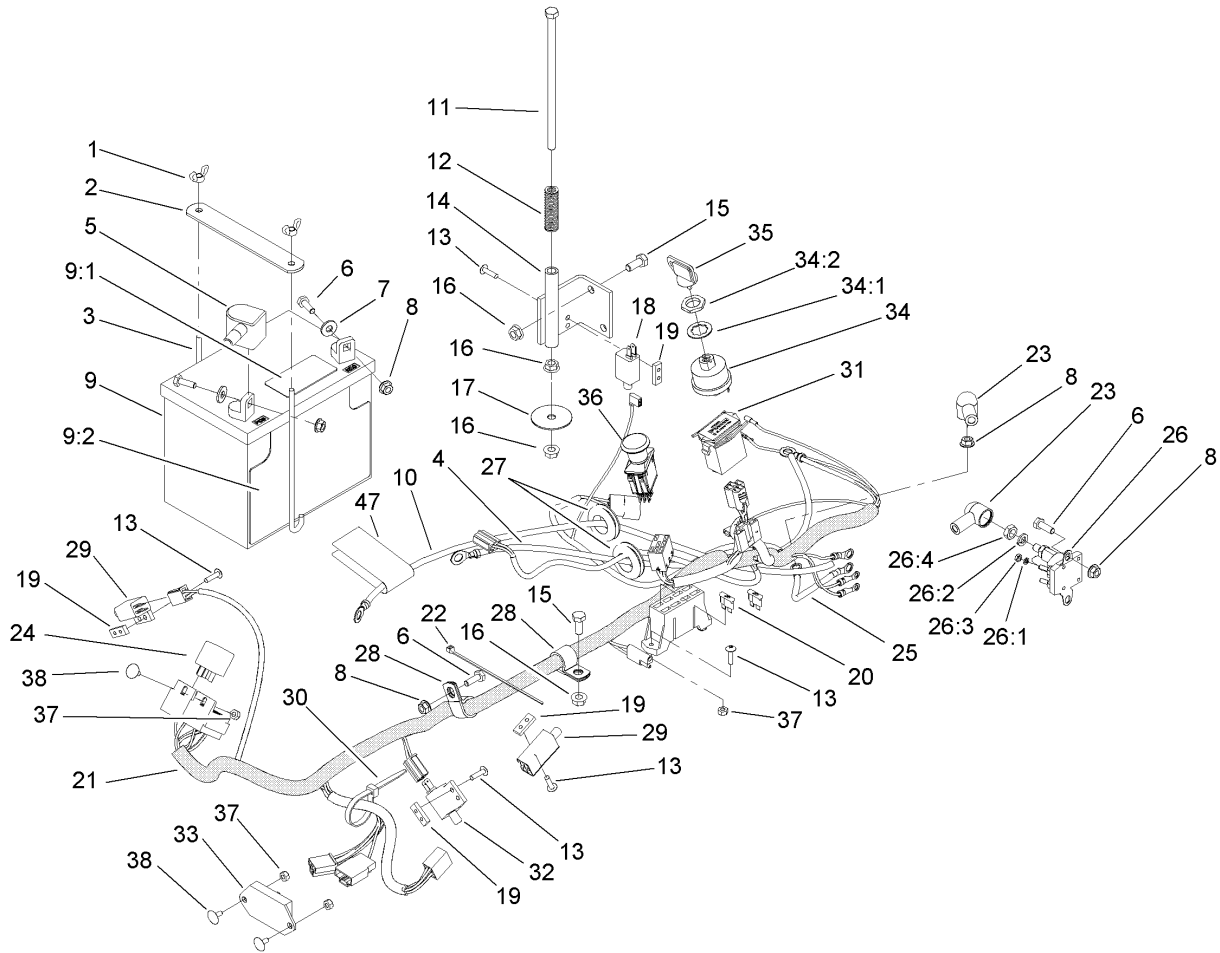
## Electrical System Assembly

Ref	Part No.	Qty.	Description
1	1-543792	2	Wingnut
2	107-9277-03	1	Strap-Holddown, Battery
3	1-633651	2	Bolt-Holddown
4	103-0705	1	Cable-Ground, Negative
5	1-543391	1	Insulator-Battery
6	321-4	5	Screw-HH
7	3256-2	2	Washer-Flat
8	32128-33	6	Nut-HF
9	105-1692	1	Battery
9:1	104-4163	1	Decal-Battery
9:2	104-4164	1	Decal-Battery
10	103-0707	1	Cable-Battery, Positive
11	1-800282	1	Screw-HH
12	1-523415	1	Spring-Switch, Seat
13	1-803075	10	Screw-Head, Truss
14	1-652072-03	1	Bracket-Switch, Seat
15	322-3	3	Screw-HH
16	32128-20	5	Nut-HF
17	1-653036	1	Washer
18	1-513152	1	Switch-Closed, Normally
19	1-633181	4	Plate-Tapped
20	1-816001	2	Fuse-Blade Type, 20 Amp
21	110-0318	1	Harness-Electrical
22	1-303287	3	Tie-Plastic

Ref	Part No.	Qty.	Description
23	1-543393	3	Insulator-Solenoid
24	1-643275	2	Relay
25	1-633306	1	Cable-Starter, Positive
26	1-513075	1	Switch-Solenoid
26:1	3253-17	2	Washer-Lock
26:2	3253-4	2	Washer-Lock
26:3	3219-4	2	Nut-Hex
26:4	3220-2	2	Nut-Jam
27	1-543286	2	Grommet
28	1-633396	2	Clip-Loom
29	1-513051	2	Switch-Open, Normally
30	1-303335	4	Tie-Plastic
31	1-513374	1	Meter-Hour
32	1-633111	1	Switch
33	100-6186	1	Module-Delay, Seat
34	103-0206	1	Switch-Starting, Key
34:1	3254-5	1	Washer-Tooth
34:2	218-461	1	Nut-HH
35	63-8360	2	Key-Ignition
36	103-5221	1	Switch-PTO
37	3296-2	6	Nut-Lock
38	1-807513	4	Bolt-CARR
47	107-9309	1	Decal-Instructions, Charging







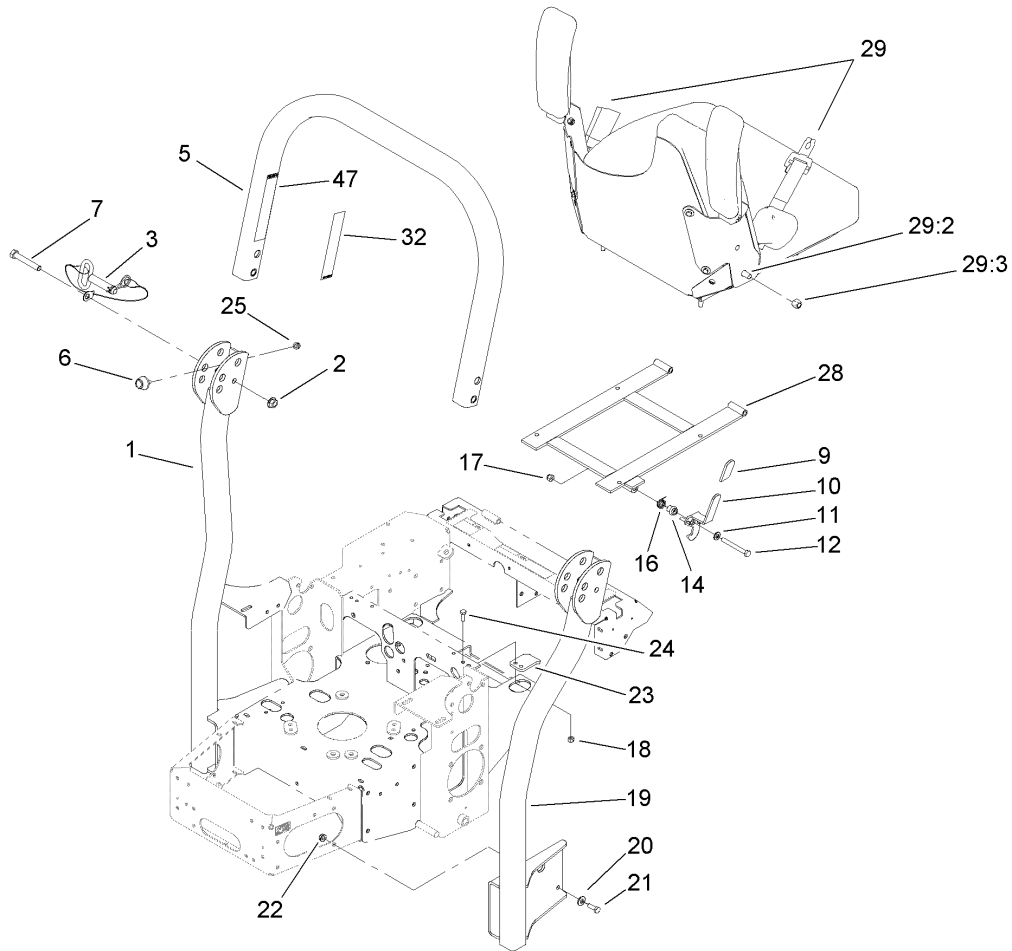

## Roll-Over Protection System Assembly No. 107-8093

Ref	Part No.	Qty.	Description
❶1		1	LH Tube Support ASM
2	32128-23	2	Nut-HF
3	103-4553	2	ROPS Fold Pin ASM
❶5		1	Upper Tube ASM
6	109-2365	2	Bumper-Rubber (W/Stud)
7	325-13	2	Screw-HH
9	103-4434	1	Grip-Lever
10	107-3083	1	Latch ASM
11	3256-24	1	Washer-Flat
12	323-20	1	Screw-HH
14	107-0075	1	Bushing-Latch, Seat
16	107-0076	1	Spring-Torsion
17	3296-39	1	Nut-Lock, NI
18	3296-29	2	Nut-Lock, NI
❶19		1	RH Tube Support ASM
20	98-5975	8	Washer-Belleville
21	323-6	8	Screw-HH
22	3290-357	8	Nut-HHF, Whiz
23	107-3059	1	Catch-Latch, Seat
24	322-4	2	Screw-HH
25	3296-73	2	Nut-Lock, NI
28	107-3052-03	1	Seat Support Frame ASM
29	110-0883	1	Retractable Seatbelt Kit
29:2	3212-4	2	Screw-HH

Ref	Part No.	Qty.	Description
29:3	3296-7	2	Nut-Lock
32	107-3069	1	Decal-Warning, Folding ROPS (Ce)
47	107-2102	1	Decal-Warning, Folding ROPS



## Cylinder / Crankcase Assembly Kawasaki FH580V AS29

Ref	Part No.	Qty.	Description				
⑤11004	11004-7016	2	Gasket-Head				
⑤11008	11008-6043	1	Head-Cylinder, No. 1				
⑤11008A	11008-7020	1	Head-Cylinder, No. 2				
⑤11022	11022-7003	2	Case-Rocker				
⑤11060	11060-7001	2	Gasket-Case, Rocker				
⑤11060A	11060-7008	1	Gasket-Cover, Crankcase				
⑤11061	11061-7001	1	Gasket-Breather				
⑤13271	13271-7016	1	Plate				
⑤14091	14091-7006	1	Cover				
⑤49015	49015-6253	1	Cover-Crankcase				
⑤49109	49109-7002	1	Element-Breather				
⑤49120	49120-7023	1	Crankcase				
⑤92033	92033-7003	2	Ring-Snap				
⑤92043	92043-7001	6	Pin				
⑤92049	92049-7001	4	Seal-Oil, Rvc2 (6X11X10.2)				
⑤92049A	92049-7015	1	Seal-Oil, Sd (35X62X8 L HSH)				
⑤92049B	92049-7016	1	Seal-Oil, Sd (35X48X8 R HSH)				
⑤92049C	92049-7019	1	Seal-Oil, So (8X14X5 HSH)				
⑤92066	92066-7002	1	Plug				
⑤130	130B0612	4	Bolt-Flanged				
⑤130A	130B0640	4	Bolt-Flanged				
⑤130B	130T0850	17	Bolt-Flanged				
⑤130C	130T0875	2	Bolt-Flanged				
⑤172	172G0818	4	Bolt-Stud				

# Piston / Crankshaft Assembly Kawasaki FH580V AS29

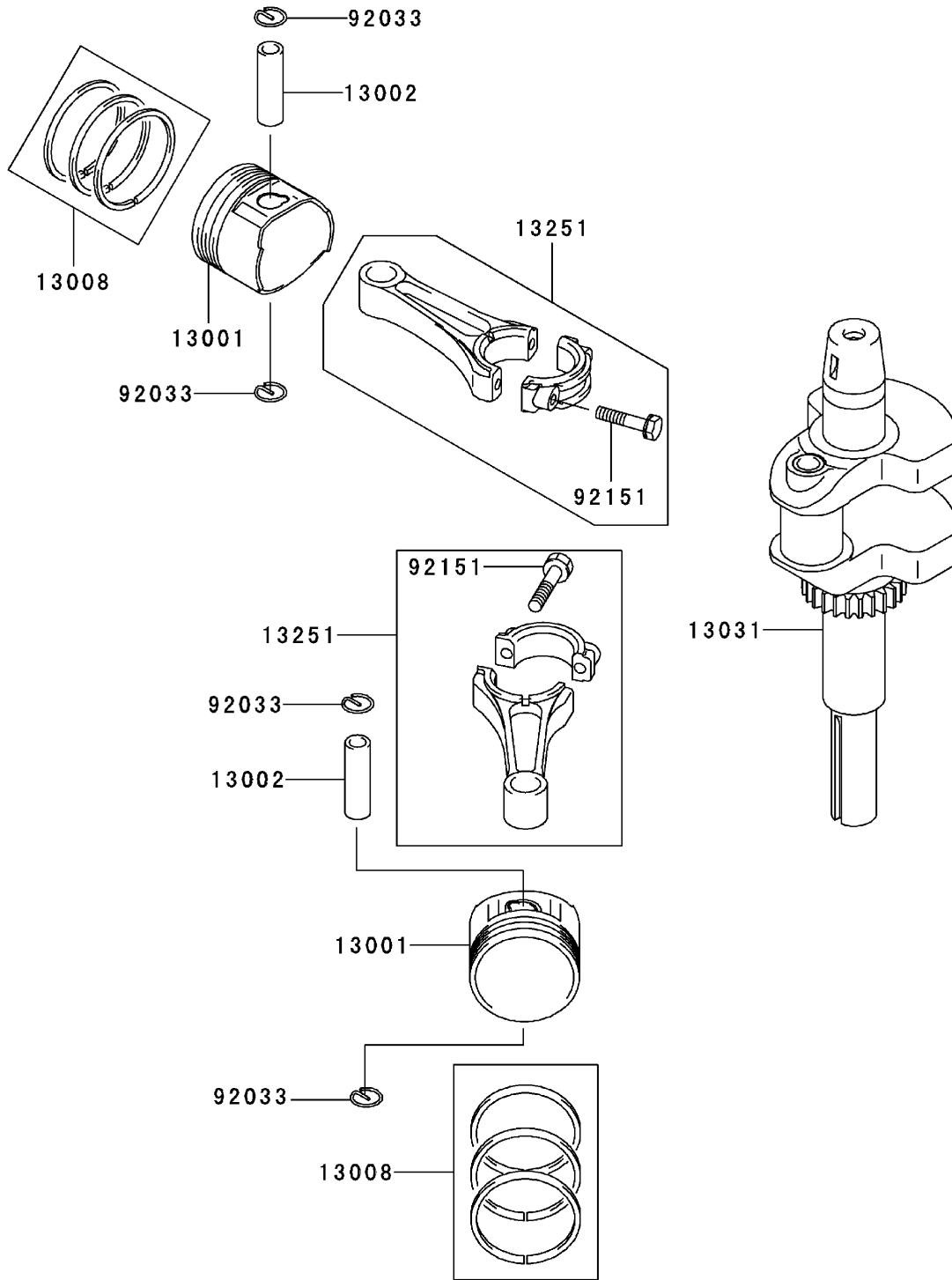

## Piston / Crankshaft Assembly Kawasaki FH580V AS29

Ref	Part No.	Qty.	Description				
⑤13001	13001-7010	2	Piston-Engine				
⑤13002	13002-7001	2	Pin-Piston				
⑤13008	13008-6060	2	Ring Set-Piston				
⑤13031	13031-7036	1	Crankshaft				
⑤13251	13251-7010	2	Connecting Rod ASM				
⑤92033	92033-7005	4	Ring-Snap				
⑤92151	92151-7017	4	Bolt (6X35)				

# Valve / Camshaft Assembly Kawasaki FH580V AS29

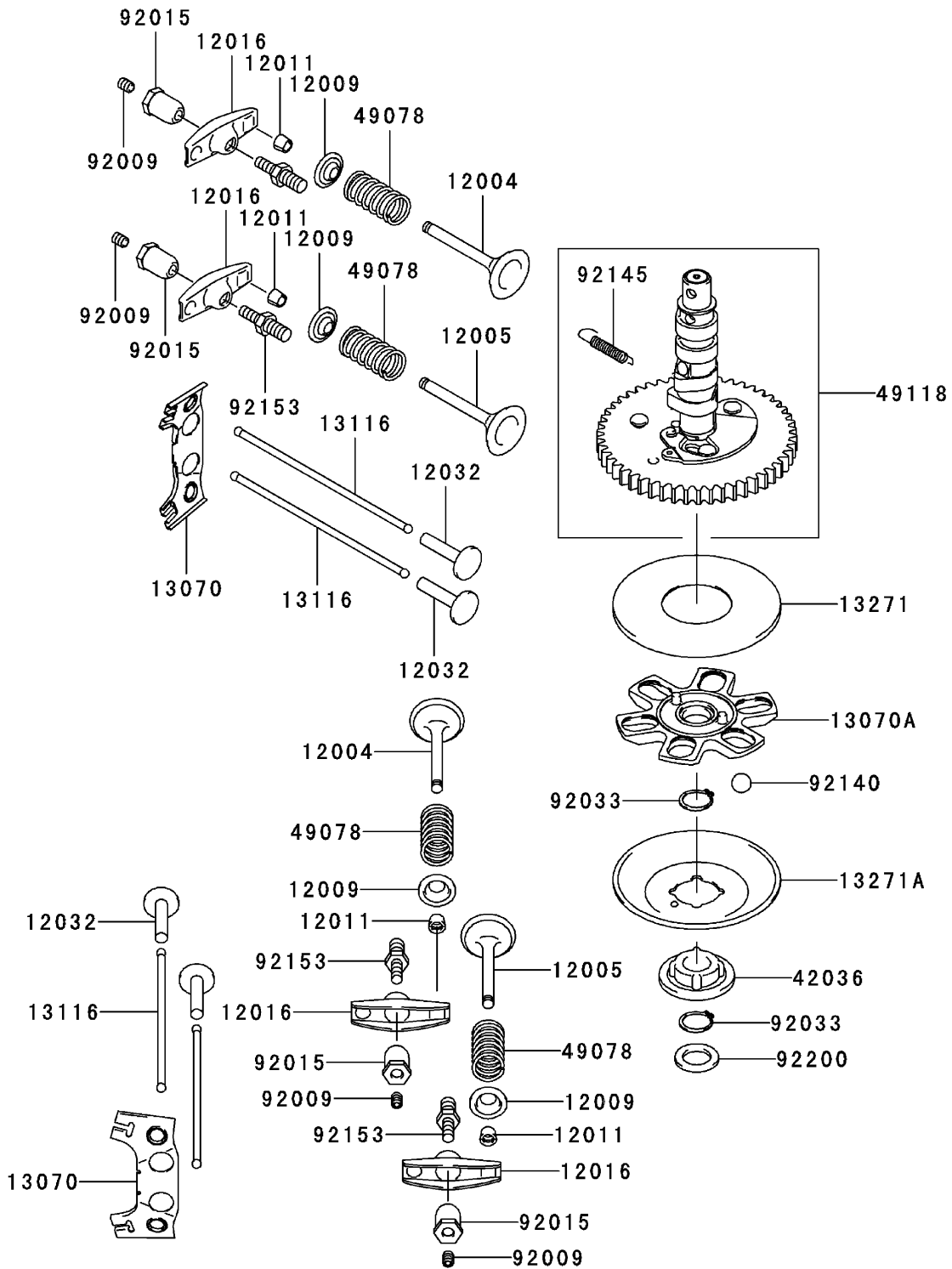

## Valve / Camshaft Assembly Kawasaki FH580V AS29

Ref	Part No.	Qty.	Description				
⑤12004	12004-7003	2	Valve-Intake				
⑤12005	12005-7003	2	Valve-Exhaust				
⑤12009	12009-7001	4	Retainer-Spring, Valve				
⑤12011	12011-2056	8	Collet				
⑤12016	12016-7001	4	Arm-Rocker				
⑤12032	12032-7001	4	Tappet				
⑤13070	13070-7001	2	Guide				
⑤13070A	13070-7004	1	Guide				
⑤13116	13116-2057	4	Rod-Push				
⑤13271	13271-7007	1	Plate				
⑤13271A	13271-7021	1	Plate-Governor				
⑤42036	42036-7009	1	Sleeve				
⑤49078	49078-7001	4	Spring-Valve, Engine				
⑤49118	49118-7004	1	Camshaft				
⑤92009	92009-2341	4	Screw				
⑤92015	92015-2253	4	Nut				
⑤92033	92033-7001	2	Ring-Snap				
⑤92140	92140-7002	6	Ball				
⑤92145	92145-7001	1	Spring				
⑤92153	92153-7019	4	Bolt				
⑤92200	92200-7001	1	Washer				

# Lubrication Equipment Assembly Kawasaki FH580V AS29

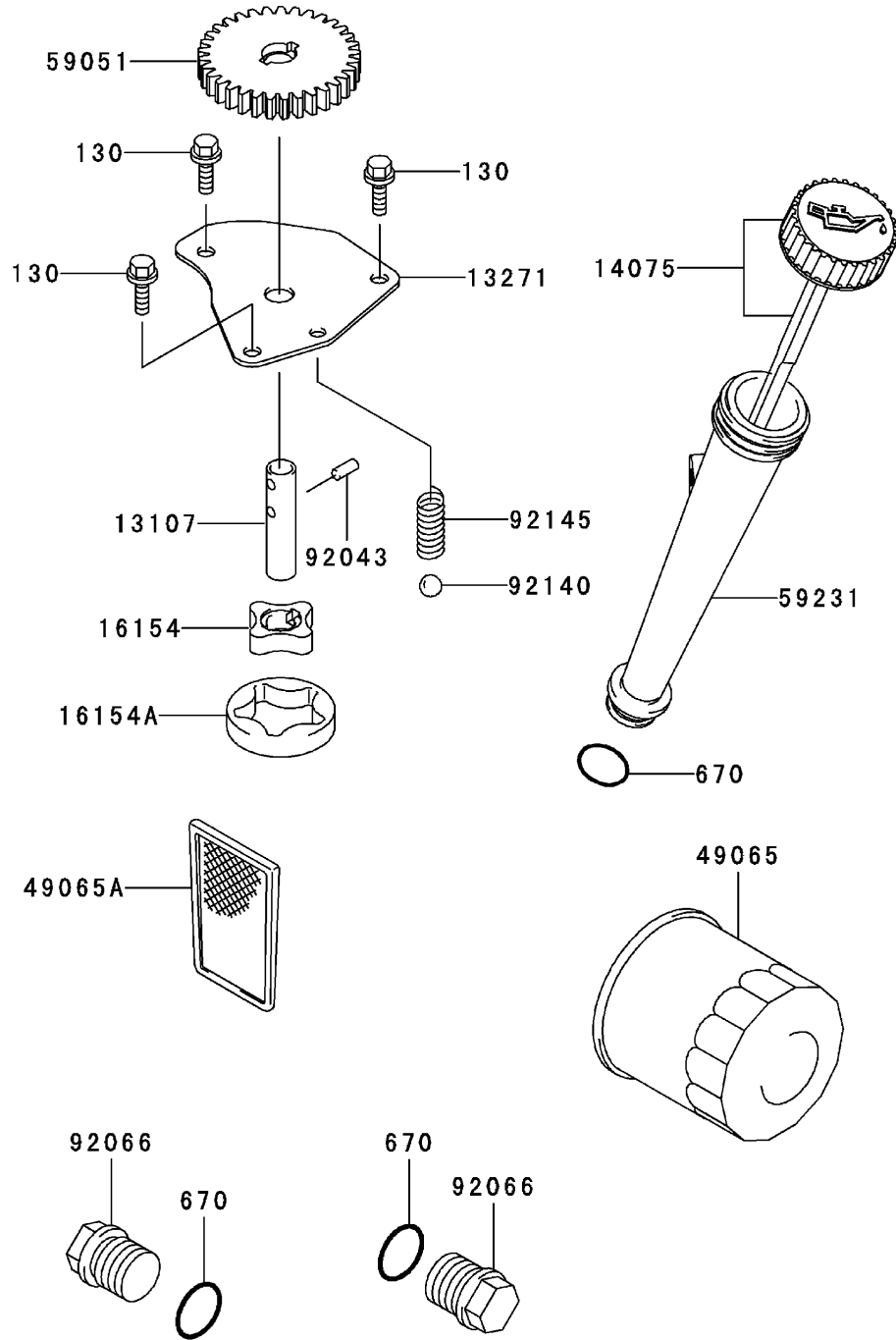

## Lubrication Equipment Assembly Kawasaki FH580V AS29

Ref	Part No.	Qty.	Description				
③13107	13107-7009	1	Shaft				
③13271	13271-7017	1	Plate				
③14075	14075-7009	1	Cap ASM				
③16154	16154-2053	1	Rotor-Pump (In)				
③16154A	16154-2054	1	Rotor-Pump (Out)				
③49065	49065-2078	1	Filter-Oil				
③49065A	49065-7004	1	Filter-Oil				
③59051	59051-7011	1	Gear-Spur				
③59231	59231-7005	1	Filler				
③92043	92043-7003	2	Pin				
③92066	92066-7003	2	Plug				
③92140	92140-7003	1	Ball				
③92145	92145-7002	1	Spring				
③130	130B0612	3	Bolt-Flanged				
③670	670D2016	3	O-Ring (16Mm)				

# Cooling Equipment Assembly Kawasaki FH580V AS29

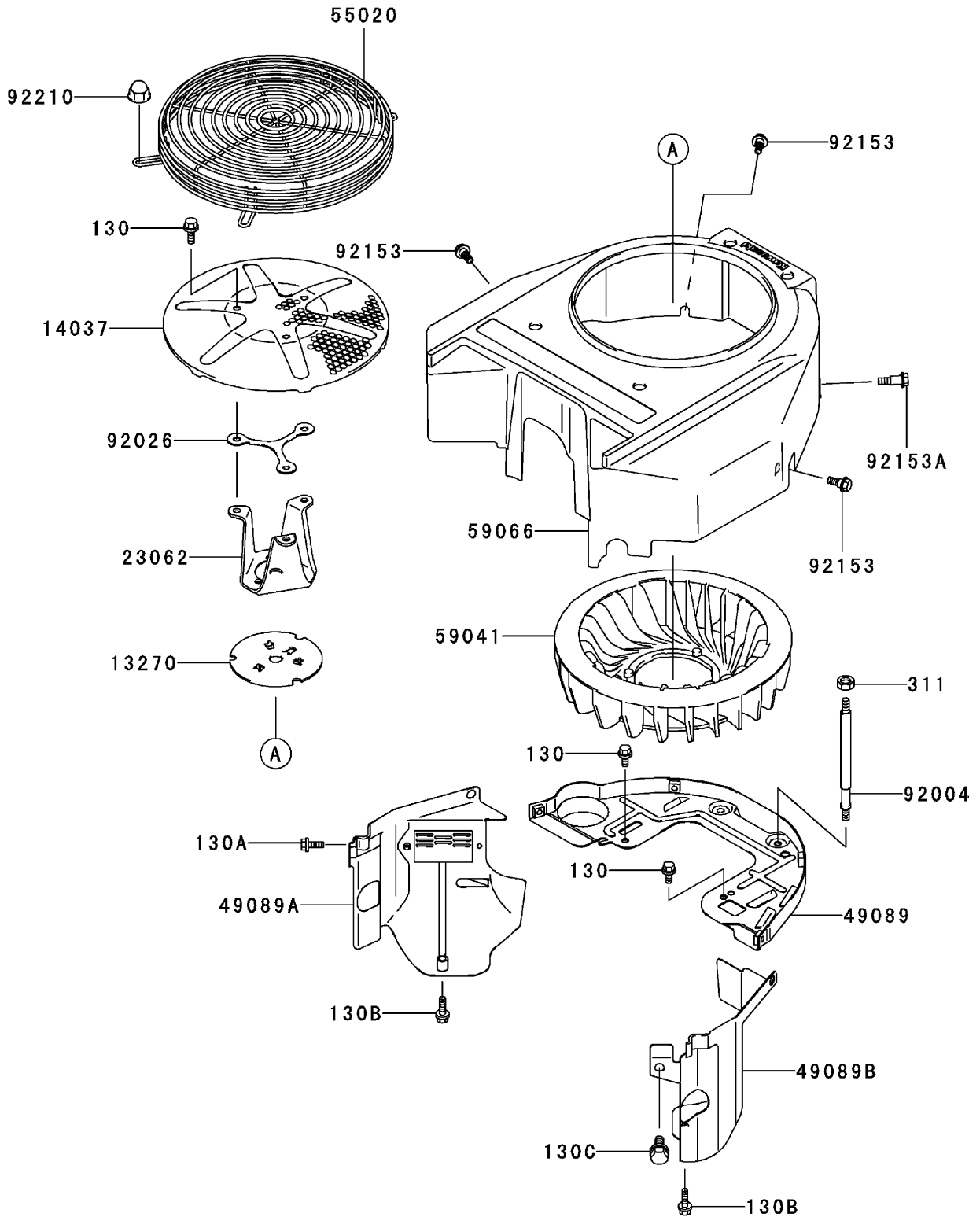

# Cooling Equipment Assembly

## Kawasaki FH580V AS29

Ref	Part No.	Qty.	Description				
③13270	13270-7007	1	Plate				
③14037	14037-7020-9H	1	Screen				
③23062	23062-7010	1	Bracket				
③49089	49089-7032	1	Shroud-Engine				
③49089A	49089-7042	1	Shroud-Engine				
③49089B	49089-7043	1	Shroud-Engine				
③55020	55020-7004	1	Guard				
③59041	59041-7010	1	Fan				
③59066	59066-7025	1	Housing-Fan				
③92004	92004-7006	2	Stud				
③92026	92026-7007	1	Spacer				
③92153	92153-7007	3	Bolt				
③92153A	92153-7008	1	Bolt				
③92210	92210-0003	4	Nut				
③130	130B0612	5	Bolt-Flanged				
③130A	130B0616	2	Bolt-Flanged				
③130B	130B0625	2	Bolt-Flanged				
③130C	130B0816	1	Bolt-Flanged				
③311	311B0600	2	Nut-Hex				

# Electric Equipment Assembly Kawasaki FH580V AS29

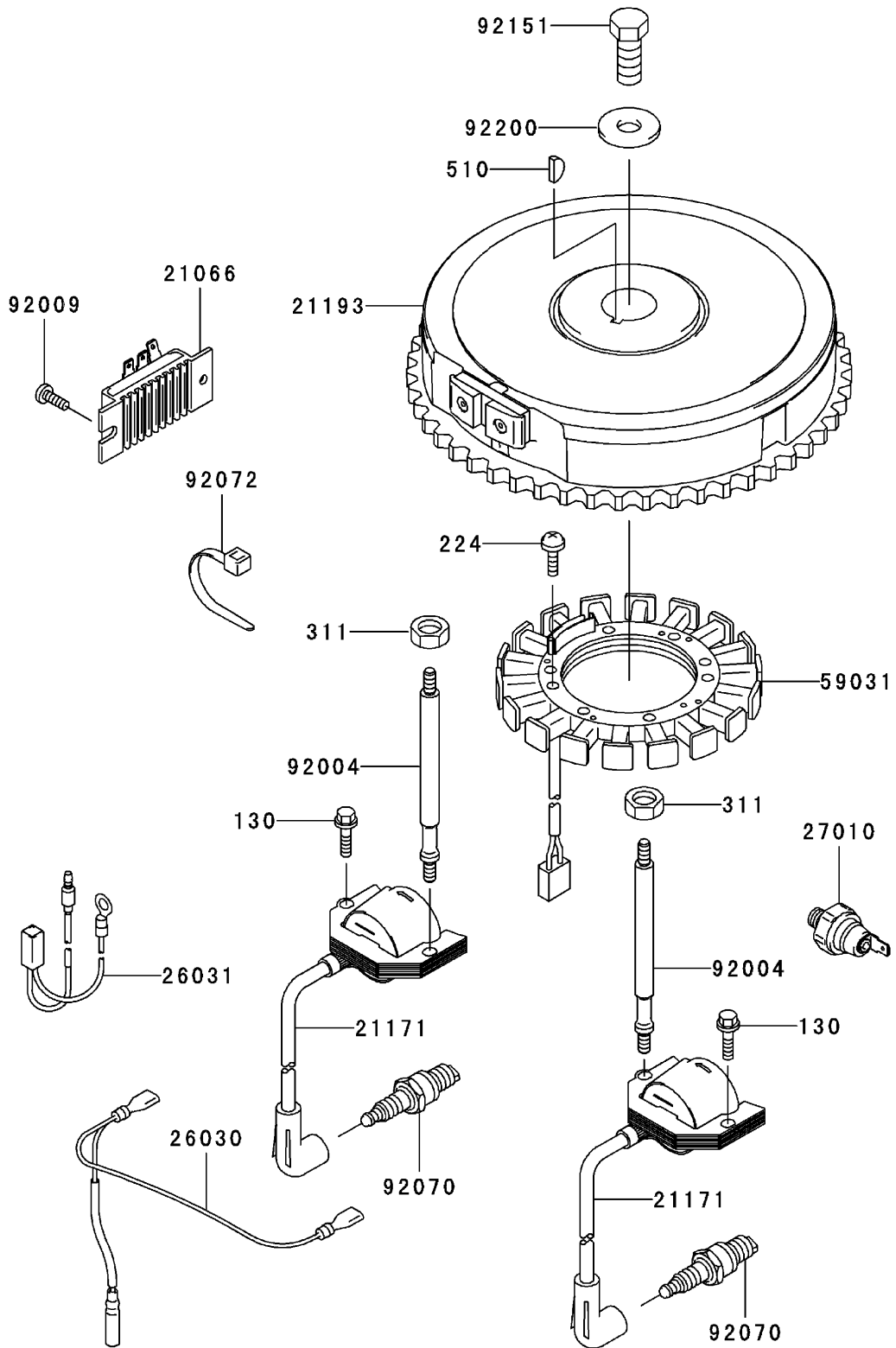

## Electric Equipment Assembly Kawasaki FH580V AS29

Ref	Part No.	Qty.	Description				
③21066	21066-7011	1	Regulator-Voltage				
③21171	21171-7013	2	Ignition Coil ASM				
③21193	21193-7007	1	Flywheel ASM				
③26030	26030-7001	1	Harness				
③26031	26031-7002	1	Harness				
③27010	27010-7001	1	Switch				
③59031	59031-7001	1	Coil-Charging				
③92004	92004-7009	2	Stud				
③92009	92009-2308	1	Screw				
③92070	92070-7003	2	Plug-Spark (Rcj8Y, Solid)				
③92072	92072-7003	2	Band				
③92151	92151-2097	1	Bolt (12X30)				
③92200	92200-7002	1	Washer				
③130	130B0620	2	Bolt-Flanged				
③224	224B0520	4	Screw-Pan				
③311	311B0600	2	Nut-Hex				
③510	510A5100	1	Key-Woodruff				

# Control Equipment Assembly Kawasaki FH580V AS29

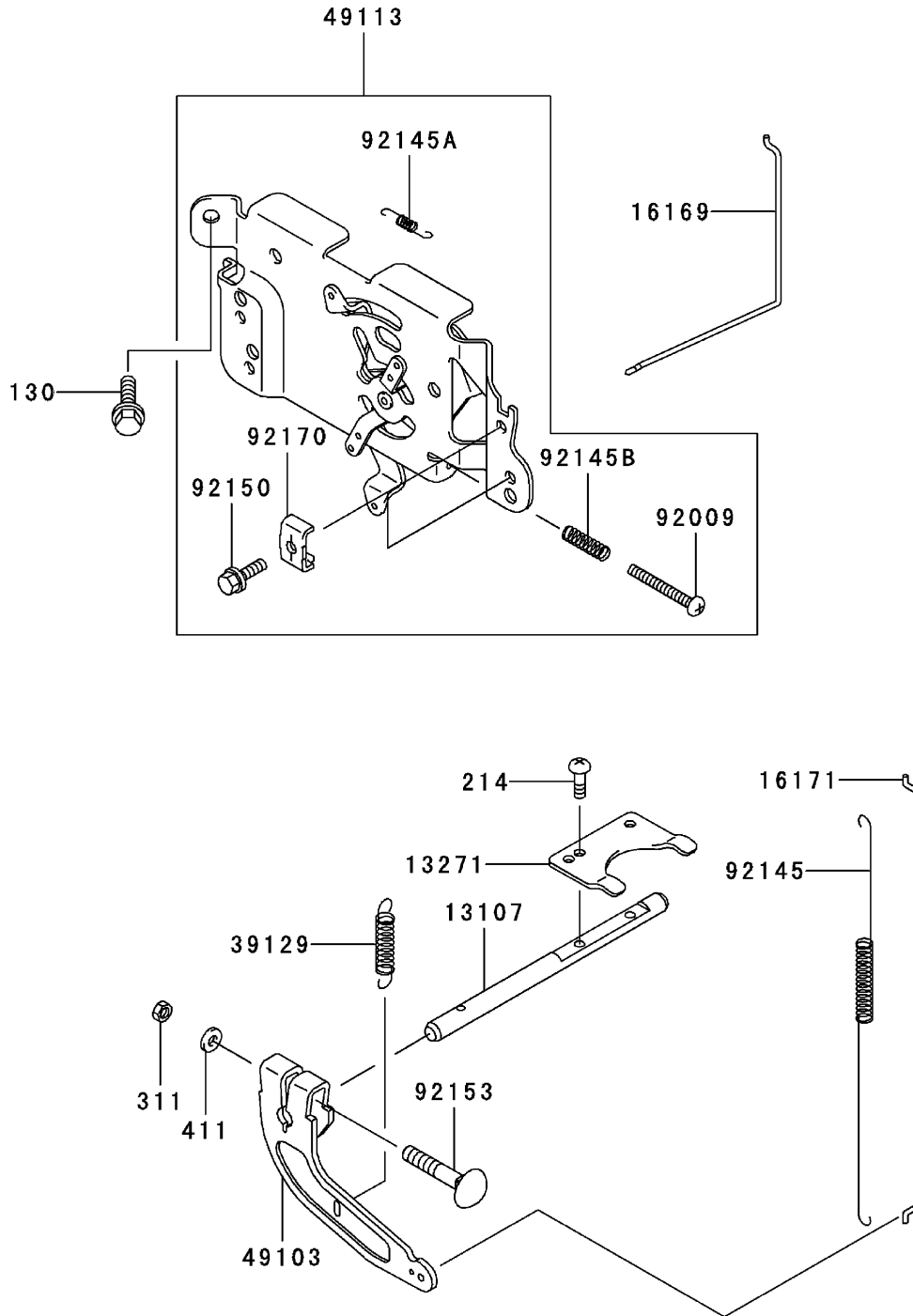

## Control Equipment Assembly Kawasaki FH580V AS29

Ref	Part No.	Qty.	Description				
③13107	13107-7010	1	Shaft				
③13271	13271-7018	1	Plate				
③16169	16169-7010	1	Link-Choke				
③16171	16171-7001	1	Link				
③39129	39129-7003	1	Spring-Governor				
③49103	49103-7004	1	Arm-Governor				
③49113	49113-7011	1	Panel-Control				
③92009	92009-7007	1	Screw (4X35)				
③92145	92145-7003	1	Spring				
③92145A	92145-7004	1	Spring				
③92145B	92145-7005	1	Spring				
③92150	92150-2182	2	Bolt (5X18)				
③92153	92153-7033	1	Bolt (6X35)				
③92170	92170-7001	2	Clamp				
③130	130B0612	2	Bolt-Flanged				
③214	214B0408	2	Screw-Pan				
③311	311B0600	1	Nut-Hex				
③411	411b0600	1	Washer-Plain				

# Carburetor Assembly Kawasaki FH580V AS29

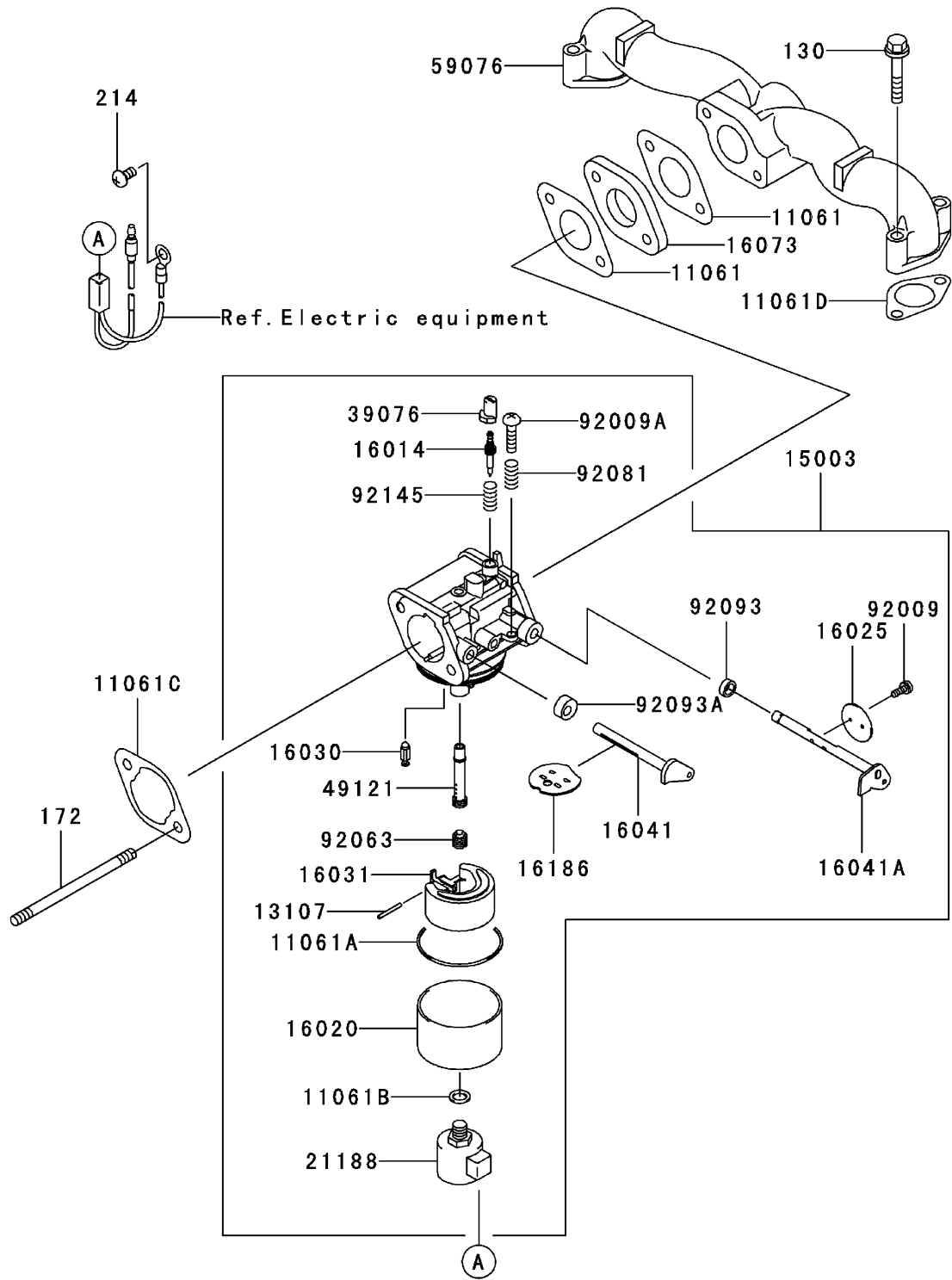

## Carburetor Assembly Kawasaki FH580V AS29

Ref	Part No.	Qty.	Description				
③11061	11061-7004	2	Gasket-Insulator				
③11061A	11061-7009	1	Gasket-Chamber				
③11061B	11061-7010	1	Gasket-Screw				
③11061C	11061-7018	1	Gasket-Cleaner, Air				
③11061D	11061-7019	2	Gasket				
③13107	13107-7018	1	Shaft				
③15003	15003-7100	1	Carburetor ASM				
③16014	16014-7007	1	Screw-Air, Pilot				
③16020	16020-7003	1	Chamber-Float				
③16025	16025-7006	1	Valve-Throttle				
③16030	16030-7003	1	Valve-Float				
③16031	16031-7002	1	Float				
③16041	16041-7016	1	Shaft-Choke, Carburetor				
③16041A	16041-7018	1	Shaft-Throttle, Carburetor				
③16073	16073-7007	1	Insulator				
③16186	16186-7004	1	Choke Valve ASM				
③21188	21188-7002	1	Solenoid				
③39076	39076-7001	1	Limiter				
③49121	49121-7004	1	Nozzle-Main				
③59076	59076-7001	1	Manifold-Intake				
③92009	92009-2083	2	Screw				
③92009A	92009-2349	1	Screw				
③92063	92063-7062	1	Jet-Main, No.110				
③92081	92081-2234	1	Spring				
③92093	92093-2100	1	Seal				
③92093A	92093-7003	1	Seal				
③92145	92145-7015	1	Spring				
③130	130B0635	4	Bolt-Flanged				
③172	172G0690	2	Bolt-Stud				
③214	214B0510	1	Screw-Pan				

# Air Filter / Muffler Assembly Kawasaki FH580V AS29

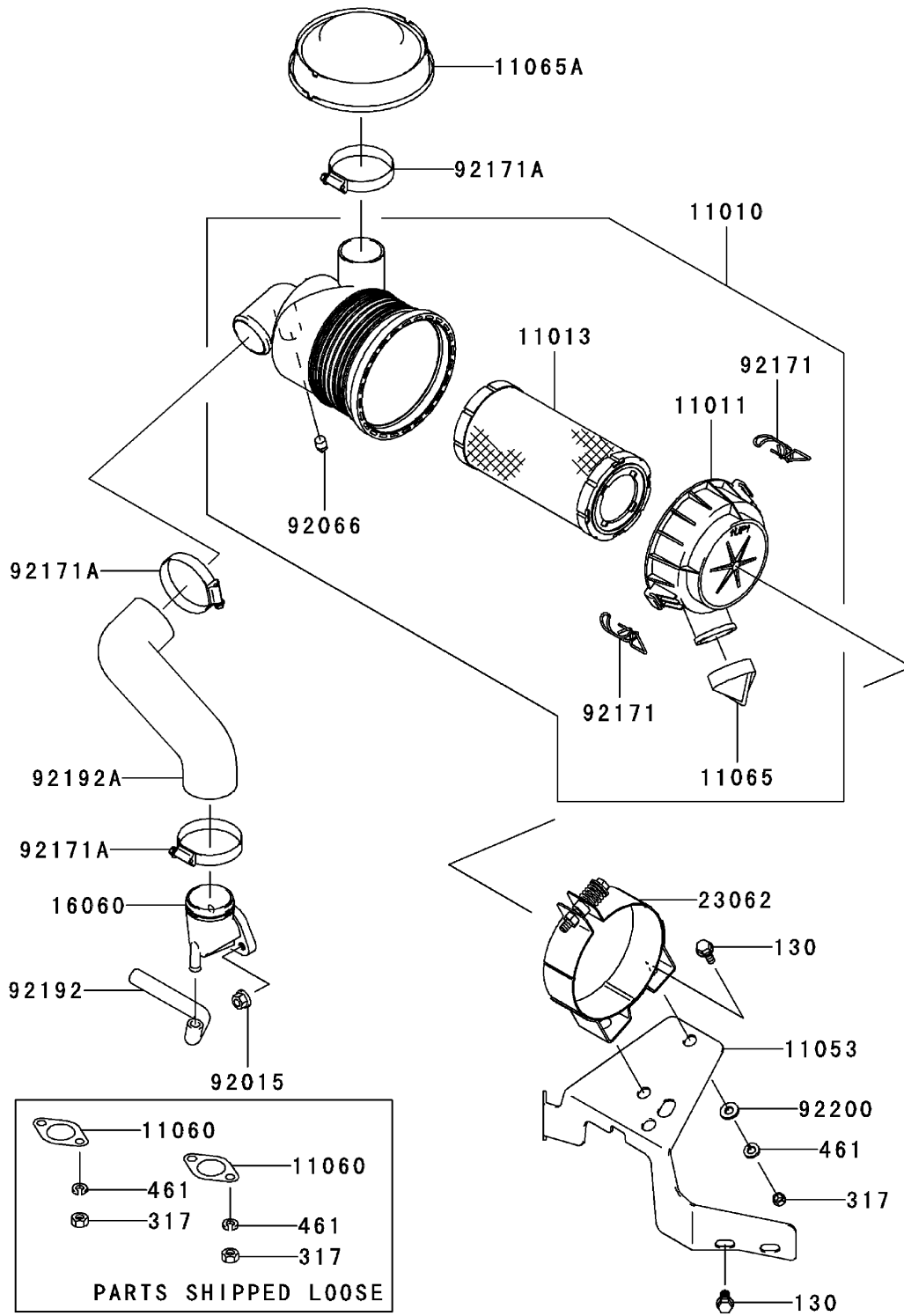

## Air Filter / Muffler Assembly Kawasaki FH580V AS29

Ref	Part No.	Qty.	Description				
③11010	11010-7017	1	Air Filter ASM				
③11011	11011-7032	1	Case-Filter, Air				
③11013	11013-7029	1	Element-Filter, Air				
③11053	11053-7019	1	Bracket				
③11060	11060-7021	2	Gasket-Muffler				
③11065	11065-7008	1	Cap				
③11065A	11065-7011	1	Cap				
③16060	16060-7011	1	Pipe-Intake				
③23062	23062-7012	1	Bracket-Comp				
③92015	92015-1193	2	Nut				
③92066	92066-7018	1	Plug				
③92171	92171-7009	2	Clamp				
③92171A	92171-7010	3	Clamp				
③92192	92192-7013	1	Tube				
③92192A	92192-7014	1	Tube				
③92200	92200-1213	2	Washer (8.5X18X2.3)				
③130	130B0816	3	Bolt-Flanged				
③317	317R0800	6	Nut-Hex				
③461	461F0800	6	Washer-Spring				

# Starter Assembly Kawasaki FH580V AS29

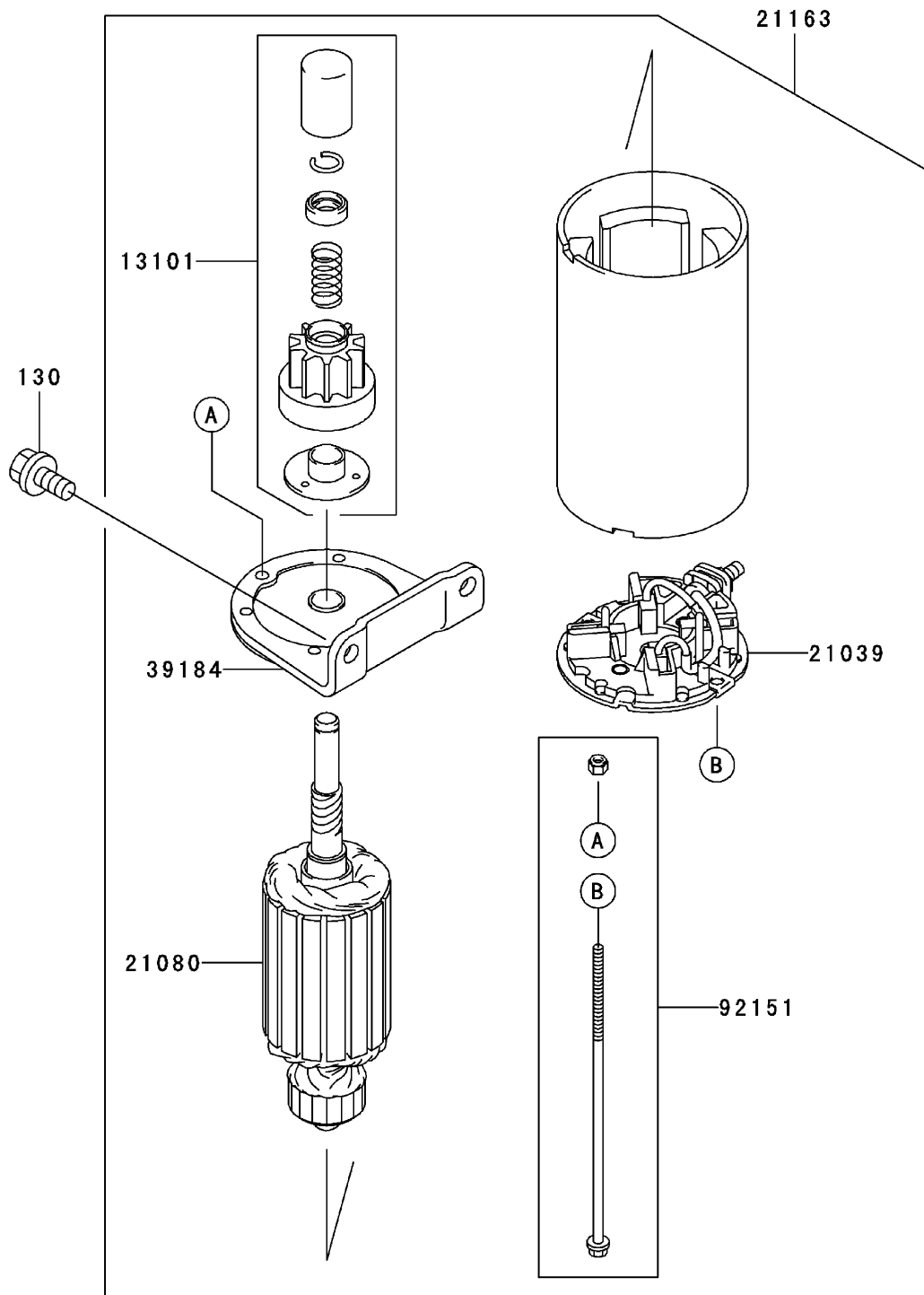

## Starter Assembly Kawasaki FH580V AS29

Ref	Part No.	Qty.	Description				
⑤13101	13101-7003	1	Gear ASM				
⑤21039	21039-7004	1	Brush				
⑤21080	21080-7001	1	Armature				
⑤21163	21163-7010	1	Starter-Electric				
⑤39184	39184-7004	1	Bracket ASM				
⑤92151	92151-7013	1	Bolt				
⑤130	130B0816	2	Bolt-Flanged				





## Attachments and Accessories

For 74413 - Z449 Z Master, With 48in TURBO FORCE Side Discharge Mower

Product Name	Model/Part
Striping Kit .....	106-3370
Deck Lift Assist Kit .....	106-9749
Deluxe Suspension Seat .....	107-1891
Suspension Kit for Standard Seat .....	107-1892
Z Stand Kit .....	107-8599
Mower Deck Lift Assist Kit .....	108-4090
Bagging Enhancement Kit .....	108-4091
Blade-Hi Flow, 16.5 Inch (6 Pack) .....	110-0414
Blade-Lo Flow, 16.5 Inch (6 Pack) .....	110-0415
Blade-Recycler, 16.5 Inch (6 Pack) .....	110-0416
Blade-Atomic, 16.5 Inch (6 Pack) .....	110-0417
Blade-Mid Flow, 16.5 Inch (6 Pack) .....	110-0418
Sunshade-Bimini .....	110-5726
Recycler Kit .....	59220
Twin Bagger .....	78507
DFS Vac Collection System .....	78510
48 Inch Finishing Kit .....	78511
Hitch Kit .....	99-8924

# NOTES

