



## Z453 Z Master<sup>®</sup> With 48in TURBO FORCE<sup>®</sup> Side Discharge Mower

Model No. 74417 - 270000001 and up.

### Parts Catalog

---

#### Ordering Replacement Parts

To order replacement parts, please supply the part number, the quantity, and the description of each part desired.

#### Understanding Reference Numbers

Each identified part in an illustration has a reference number. The reference number for a part also appears in the parts list, along with other information about the part.

This catalog uses two special reference number formats, one to indicate parts in a service assembly and another to indicate the quantity of a given part in an illustration.

#### Service Assembly Reference Numbers

Parts in service assemblies have reference numbers in the form a:b. The a represents the reference number of the entire service assembly and the b represents a sequential number unique to each part within the service assembly.

For example, a wheel assembly might be identified by reference number 6, the tire by 6:1, the valve by 6:2, and the wheel by 6:3. When you order the assembly identified by reference number 6, you receive all parts identified by reference numbers 6:1, 6:2, and 6:3. However, you may also order any part individually. Reference numbers of this type appear in illustrations and in part lists.

#### Reference Numbers Indicating Quantity

In an illustration, if a reference number indicates more than one part, the reference number has the form nX y. The n represents the quantity of the part, the X is the multiplication symbol, and the y represents the reference number.

For example, in an illustration, the reference number 2X 37 means that two of the parts identified by reference number 37 are indicated.

# Contents

Description	Page	Description	Page
Front Frame Assembly	..... 3	Piston / Crankshaft Assembly Kawasaki FH680V-AS21	..... 28
Caster Wheel Assembly No. 110-5745	..... 4	Cylinder and Crankcase Assembly Kawasaki FH680V-AS21	..... 29
Height-of-Cut Assembly	..... 5	Valve / Camshaft Assembly Kawasaki FH680V-AS21	..... 30
Main Frame Assembly	..... 6	Lubrication Equipment Assembly Kawasaki FH680V-AS21	..... 31
Fuel System Assembly	..... 7	Cooling Equipment Assembly Kawasaki FH680V-AS21	..... 32
Parking Brake Assembly	..... 8	Electric Equipment Assembly Kawasaki FH680V-AS21	..... 33
Motion Control Assembly	..... 9	Control Equipment Assembly Kawasaki FH680V-AS21	..... 34
Hydraulic System Assembly	..... 11	Carburetor Assembly Kawasaki FH680V-AS21	..... 35
Hydraulic Pump Assembly No. 103-1942	..... 13	Air Filter and Muffler Assembly Kawasaki FH680V-AS21	..... 36
Pump Idler and Belt Assembly	..... 14	Starter Assembly Kawasaki FH680V-AS21	..... 37
Engine, Clutch and Muffler Assembly	..... 15	Fuel Tank / Fuel Valve Assembly Kawasaki FH680V-AS21	..... 38
Deck Connection Assembly	..... 16	Decal Assembly Kawasaki FH680V-AS21	..... 39
Deck Assembly No. 107-3190	..... 17	Attachments and Accessories List	..... 40
Deck Decal Assembly No. 107-8515	..... 19		
Spindle Assembly No. 107-8504	..... 20		
Rubber Deflector Assembly No. 108-2792	..... 21		
Idler Assembly	..... 22		
Electrical System Assembly	..... 23		
Seat and Bracket Assembly	..... 24		
Seat Assembly No. 110-0446	..... 25		
Roll-Over Protection System Assembly	..... 26		
Roll-Over Protection System Assembly No. 107-8093	..... 27		

## Part Description Abbreviations

Part descriptions in this catalog may include the following abbreviations.

AR. .... as required	HYD. .... hydraulic
ASM. .... assembly	LH. .... left hand
BBC. .... blade brake clutch	NI. .... nylon insert
CARR. .... carriage	NPTF. .... national pipe thread fine
DEG. .... degrees	PFH. .... phillips flat head
EXT. .... external	PPH. .... phillips pan head
FH. .... flat head	PPHTF. .... phillips pan head thread forming
GA. .... gauge	PRH. .... phillips round head
HD. .... heavy-duty	PTH. .... phillips truss head
HF. .... hex flange	PTO. .... power-take-off
HH. .... hex head	RH. .... right hand
HHF. .... hex head flange	ROPS. .... roll-over protection system
HHFTF. .... hex head flange thread forming	SFH. .... slotted fillister head
HJ. .... hex jam	SHH. .... slotted hex head
HLH. .... hex lag head	SHWH. .... slotted hex washer head
HOC. .... height-of-cut	SPH. .... slotted pan head
HSBH. .... hex socket button head	SQH. .... square head
HSFH. .... hex socket flat head	SRH. .... slotted round head
HSH. .... hex socket head	STD. .... standard
HWH. .... hex washer head	TAP. .... self tapping
HWHTF. .... hex washer head thread forming	TTH. .... torx truss head

## Footnotes

- ❶ Not serviced separately
- ❷ Optional Equipment

- ❸ Obtain Parts From Kawasaki

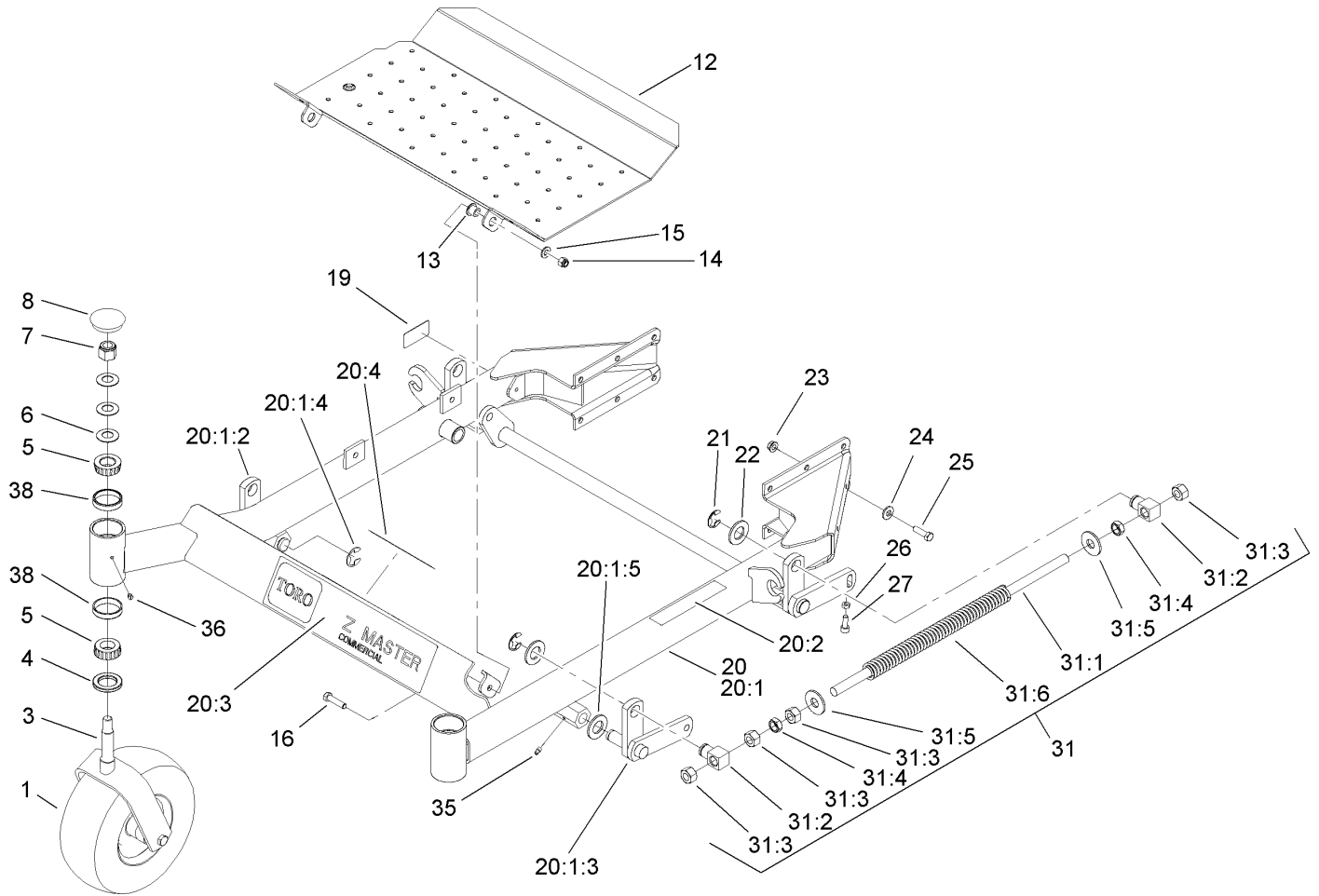

## Front Frame Assembly

Ref	Part No.	Qty.	Description
1	110-5745	2	Semi Pnuematic Wheel ASM
3	1-632511-01	2	Caster
4	1-543511	2	Seal-Grease
5	254-94	4	Bearing-Cone, Tapered
6	1-633508	6	Washer-Bellville
7	3296-51	2	Nut-Lock, NI
8	103-4882	2	Cap-Grease
12	108-5007-03	1	Floor Pan
13	86-2180	2	Bushing-Flange
14	3296-39	2	Nut-Lock, NI
15	3256-24	2	Washer-Flat
16	323-8	2	Screw-HH
19	108-5278	1	Decal
20	108-5022	1	Front Frame ASM
● 20:1		1	Frame-Front
20:1:2	99-3872-01	1	RH Lift Arm ASM
20:1:3	99-3871-01	1	LH Lift Arm ASM
20:1:4	32151-103	2	Ring-Snap
20:1:5	3256-29	2	Washer-Flat
20:2	1-633818	1	Decal-Warning
20:3	106-7451	1	Decal
20:4	107-2112	1	Decal-Warning
21	32151-103	4	Ring-Snap
22	3256-29	4	Washer-Flat

Ref	Part No.	Qty.	Description
23	3290-357	12	Nut-HHF, Whiz
24	98-5975	12	Washer-Bellville
25	323-7	12	Screw-HH
26	3218-2	2	Nut-Jam
27	3274-18	2	Screw-HSH
31	1-634439	2	Front Frame Spring ASM
31:1	1-633096	1	Rod-Lift, Deck
31:2	1-633441	2	Swivel-Deck Mount, Rear
31:3	3217-11	4	Nut-Hex
31:4	3218-6	2	Nut-Jam
31:5	3256-7	2	Washer-Flat
31:6	1-633064	1	Spring-Support, Deck
35	302-19	4	Fitting-Grease
36	1-811010	2	Plug
38	254-72	4	Bearing-Cup, Tapered

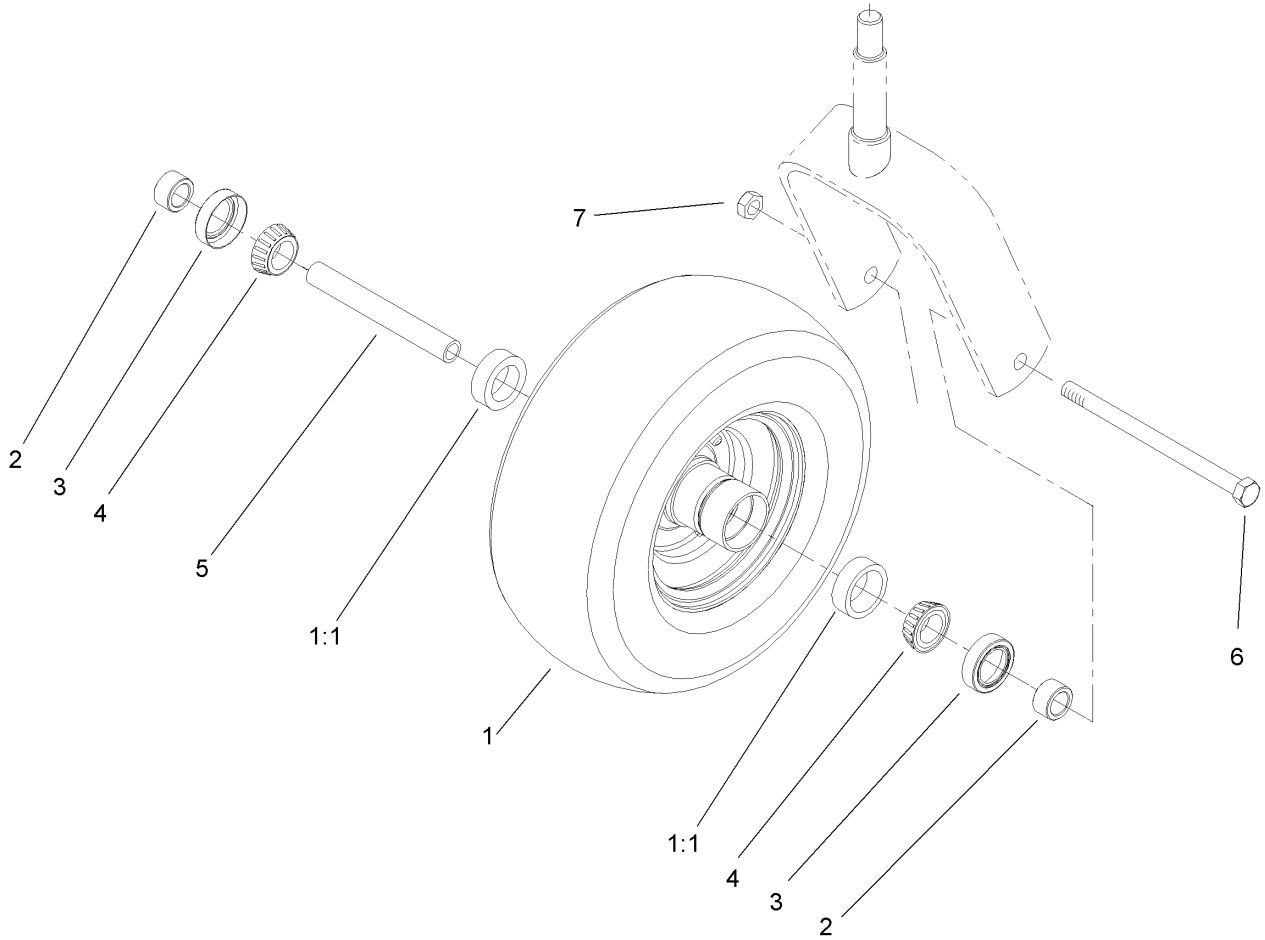

## Caster Wheel Assembly No. 110-5745

Ref	Part No.	Qty.	Description
1	110-5743	1	Wheel And Tire ASM (Semi-Pneumatic)
1:1	1-633584	2	Bearing-Cup
2	1-633581	2	Spacer-Bearing
3	1-633580	2	Seal-Bearing
4	1-633585	2	Bearing-Cone, Taper
5	1-633579	1	Spacer-Caster, Front
6	325-36	1	Screw-HH
7	3296-45	1	Nut-Lock, NI

--	--	--	--





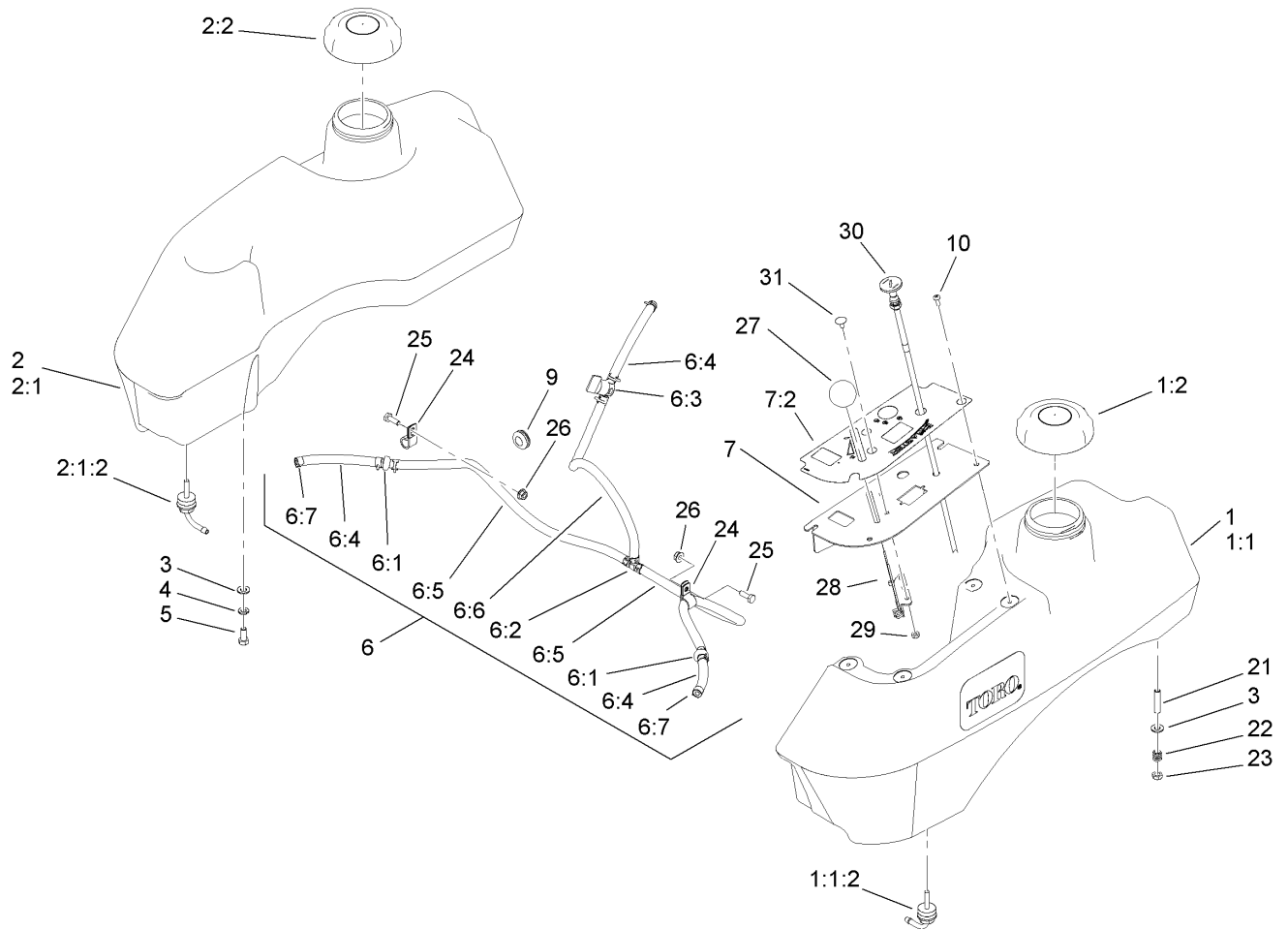

## Fuel System Assembly

Ref	Part No.	Qty.	Description
1	110-4165	1	LH Fuel Tank Service Kit
1:1		1	LH Fuel Tank ASM
1:1:2	103-2605	1	Fitting-Fuel, Bulkhead
1:2	109-0346	1	Cap-Fuel, Gas
2	105-3639	1	RH Fuel Tank Service Kit
2:1		1	RH Fuel Tank ASM
2:1:2	103-2605	1	Fitting-Fuel, Bulkhead
2:2	103-2605	1	Fitting-Fuel, Bulkhead
2:2	109-0346	1	Cap-Fuel, Gas
3	3256-23	8	Washer-Flat
4	1-805005	4	Washer-Lock
5	322-3	4	Screw-HH
6		1	Fuel Line ASM
6:1	99-5000	2	Valve-Check, Fuel
6:2	99-5005	1	Fitting-Tee, Barbed
6:3	1-603770	1	Valve-Fuel
6:4	109-0678	3	Hose-Fuel
6:5	110-5701	2	Hose-Fuel
6:6	109-0297	1	Hose-Fuel
6:7	1-303077	12	Clamp
7	107-2149	1	Control Panel ASM
7:2	110-0439	1	Decal-Panel, Control
9	1-543296	2	Grommet
10	1-803071	4	Screw

Ref	Part No.	Qty.	Description
21	1-633023	4	Stud
22	1-633349	4	Spring-Tank, Fuel
23	3296-47	4	Nut-Lock, NI
24	1-513762	2	Clip-Loom
25	321-4	2	Screw-HH
26	32128-33	2	Nut-HF
27	1-513592	1	Knob-Ball
28	1-633696	1	Throttle Cable ASM
29	3296-2	2	Nut-Lock
30	106-9962	1	Control-Choke, Push / Pull
31	1-807513	2	Bolt-CARR

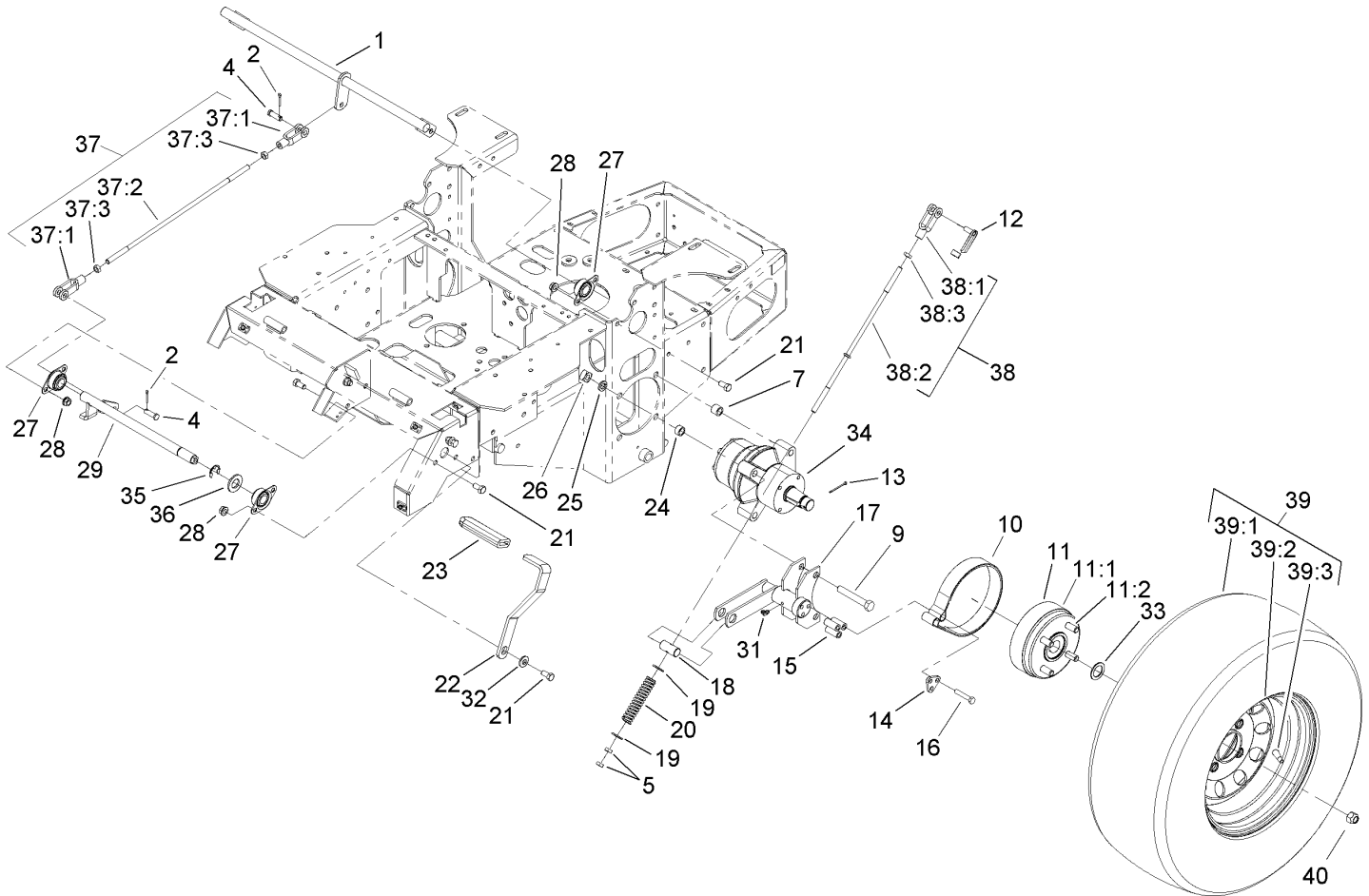

## Parking Brake Assembly

Ref	Part No.	Qty.	Description
1	1-652073-03	1	Crank-Brake, Park
2	3272-10	2	Pin-Cotter
4	1-808285	2	Pin-Clevis
5	3219-3	4	Nut-Hex
7	1-653068	4	Spacer-Wheel
9	325-13	8	Screw-HH
10	103-0355	2	Band-Brake
11	103-0590	2	Hub And Wheel ASM
11:1	103-0589	1	Wheel Hub ASM
11:2	1-633926	4	Stud-Wheel
12	103-2399	2	Pin-Spring, Clevis
13	1-806800	2	Pin-Cotter
14	103-0374	2	Retainer-Band, Brake
15	103-0384	6	Spacer
16	322-9	6	Screw-HH
17	103-0352-03	2	Bracket-Brake
18	1-633144	2	Pin-Trunion
19	3256-4	4	Washer-Flat
20	1-633454	2	Spring-Brake
21	323-4	9	Screw-HH
22	1-653074-03	1	Handle-Brake, Park
23	1-633268	1	Grip-Lever, Brake
24	1-653069	4	Spacer-Wheel
25	3253-7	8	Washer-Lock

Ref	Part No.	Qty.	Description
26	103-0131	8	Nut-Square
27	1-633102	4	Bearing-Flange, Side
28	3290-357	8	Nut-HHF, Whiz
29	103-3116	1	Shaft-Brake, Parking
31	1481	2	Fitting-Grease
32	98-5975	1	Washer-Belleville
33	1-523157	2	Washer-Spacer, 14 GA
34	103-5333	2	Motor-Wheel
35	32151-48	1	E-Ring
36	3256-28	1	Washer-Flat
37	103-4328	1	Brake Rod ASM
37:1	1-633131	2	Yoke-Linkage, Brake
37:2	1-653061	1	Linkage-Handle, Brake
37:3	3219-3	2	Nut-Hex
38	103-4329	2	Brake Rod ASM
38:1	1-633131	1	Yoke-Linkage, Brake
38:2	103-0356	1	Rod-Brake
38:3	3219-3	1	Nut-Hex
39	1-653159	2	Wheel And Tire ASM
39:1	1-653160	1	Tire
39:2	1-653161	1	Wheel
39:3	232-27	1	Stem-Valve
40	242-50	8	Nut-Lug

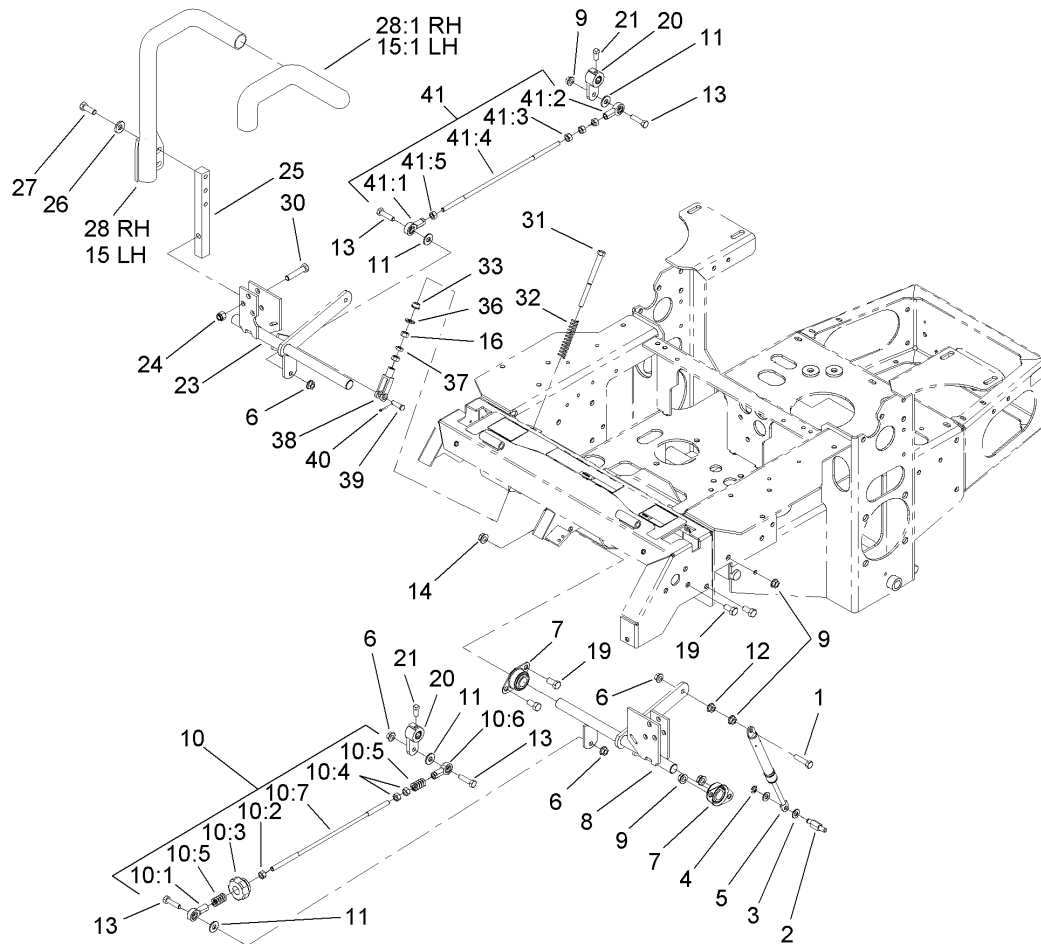

## Motion Control Assembly

Ref	Part No.	Qty.	Description
1	1-403180	2	Screw-HH
2	103-4101	2	Pin-Damper
3	3256-23	4	Washer-Flat
4	32120-35	2	E-Ring
5	109-2339	2	Damper-Control, Motion
6	3296-29	6	Nut-Lock, NI
7	1-633102	4	Bearing-Flange, Side
8	103-4774	1	Control-Motion, LH
9	32128-20	8	Nut-HF
10	103-4326	1	Tracking Rod ASM
10:1	1-543017	1	Balljoint-RH
10:2	3219-2	1	Nut-Hex
10:3	103-3060	1	Knob-Tracking
10:4	1-804524	2	Nut
10:5	1-323245	2	Spring-Compression
10:6	1-633152	1	Balljoint-Thread, LH
10:7	103-3066	1	Link-Rod, Tracking
11	3256-3	4	Washer-Flat
12	3217-6	2	Nut-Hex
13	322-6	4	Screw-HH
14	3290-357	6	Nut-HHF, Whiz
15	108-7238	1	LH Lever ASM
15:1	106-9987	1	Grip-Control, Motion
16	3219-2	4	Nut-Hex

Ref	Part No.	Qty.	Description
19	323-4	6	Screw-HH
20	103-3717	2	Arm-Control
21	1-803022	2	Screw-Set
23	103-4773	1	Control-Motion, RH
24	3296-39	6	Nut-Lock, NI
25	103-0407	2	Arm-Shaft, Control
26	98-5975	4	Washer-Belleville
27	323-6	4	Screw-HH
28	108-7237	1	RH Lever ASM
28:1	106-9987	1	Grip-Control, Motion
30	323-9	6	Screw-HH
31	1-603737	2	Bolt-Return, Neutral
32	1-603807	2	Spring-Return, Neutral
33	1-603735	2	Bushing-Flanged
36	3256-2	2	Washer-Flat
37	3220-2	2	Nut-Jam
38	1-303105	2	Yoke-Adjustable
39	1-808280	2	Pin-Clevis
40	3272-5	2	Pin-Cotter
41	103-4327	1	Tracking ASM
41:1	1-543017	1	Balljoint-RH
41:2	1-633152	1	Balljoint-Thread, LH
41:3	1-804524	1	Nut
41:4	103-3066	1	Link-Rod, Tracking



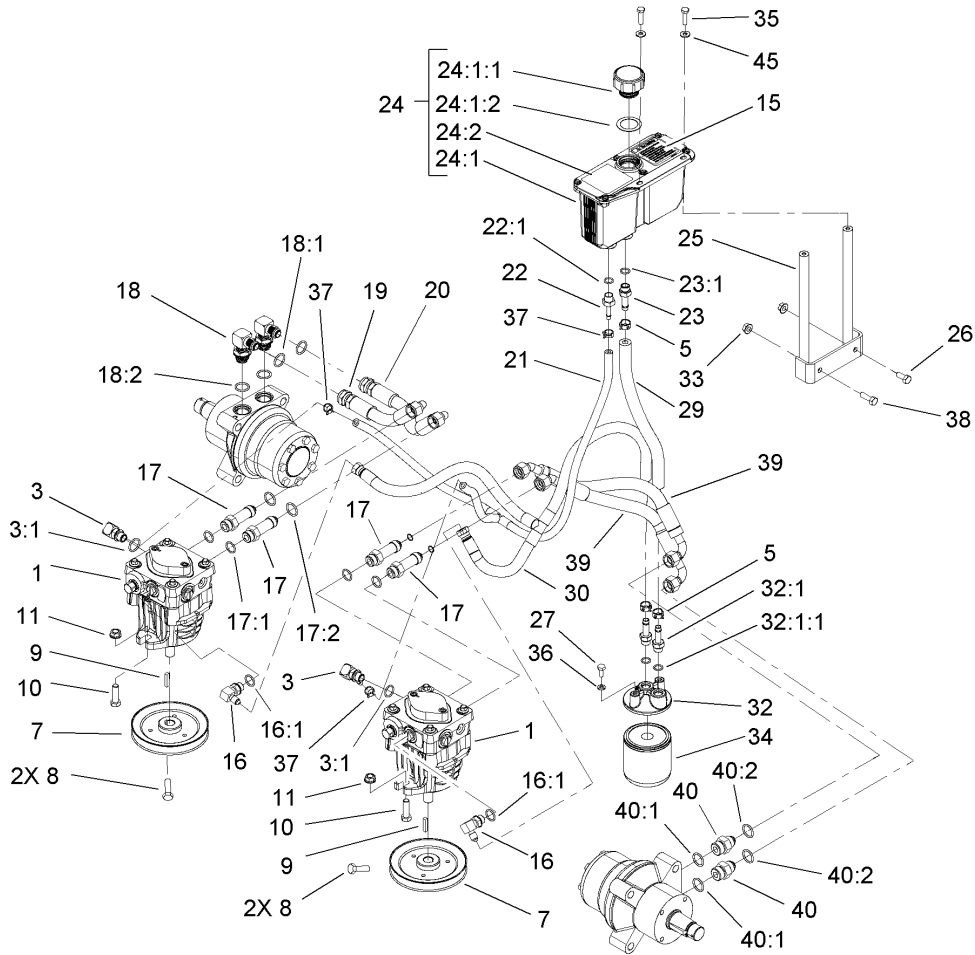

## Hydraulic System Assembly

Ref	Part No.	Qty.	Description
1	103-1942	2	Pump-HYD
3	103-1799	2	Elbow-90 DEG
3:1	237-42	1	O-Ring
5	103-1988	3	Clamp-Hose
7	1-653156	2	Pulley
8	1-803050	4	Screw-Set
9	1-807272	2	Key
10	323-7	4	Screw-HH
11	3290-357	4	Nut-HHF, Whiz
15	103-2644	1	Decal-Exhaust
16	103-1802	2	Fitting-HYD, 90 DEG
16:1	1-603921	1	O-Ring
17	103-1940	4	Adapter-HYD, Straight
17:1	237-79	1	O-Ring
17:2	1-603992	1	O-Ring
18	1-633605	2	Fitting-HYD, 90 DEG
18:1	1-603992	1	O-Ring
18:2	237-80	1	O-Ring
19	1-653186	1	Hose-Front
20	1-653187	1	Hose-Rear, RH
21	103-2357	1	HYD Hose ASM
22	103-1801	1	Adapter-Straight
22:1	237-42	1	O-Ring
23	103-1912	1	Adapter-Straight

Ref	Part No.	Qty.	Description
23:1	237-42	1	O-Ring
24	103-1947	1	HYD Reservoir ASM
24:1		1	Reservoir-HYD
24:1:1	103-1948	1	Cap-Reservoir, HYD
24:1:2	103-1949	1	Gasket-Cap
24:2	1-523552	1	Decal-Tank, HYD
25	103-3071-03	1	Stand-Reservoir
26	322-3	1	Screw-HH
27	321-3	2	Screw-HH
29	103-3077	1	HYD Hose ASM
30	103-2930	1	HYD Hose ASM
32	103-2889	1	Filter Head ASM
32:1	103-1912	2	Adapter-Straight
32:1:1	237-42	1	O-Ring
33	32128-20	2	Nut-HF
34	1-633750	1	Filter-Oil, HYD
34	1-633752	1	Filter-HYD, Winter
35	321-6	2	Screw-HH
36	1-805004	2	Washer-Lock
37	103-1716	3	Clamp-Hose
38	322-5	1	Screw-HH
39	103-3809	2	Hose-LH
40	1-603991	2	Fitting-Straight
40:1	237-80	1	O-Ring

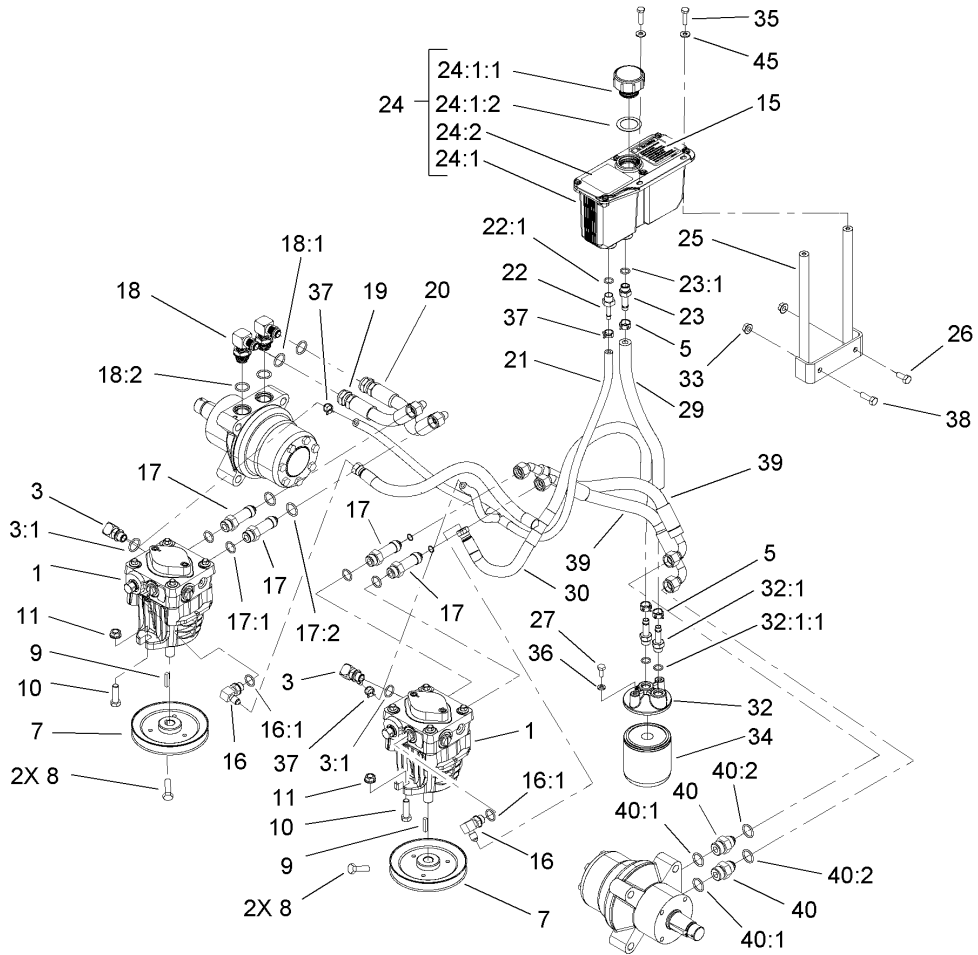

## Hydraulic System Assembly (continued)

Ref	Part No.	Qty.	Description
40:2	1-603992	1	O-Ring
45	3256-22	2	Washer-Flat

--	--	--	--



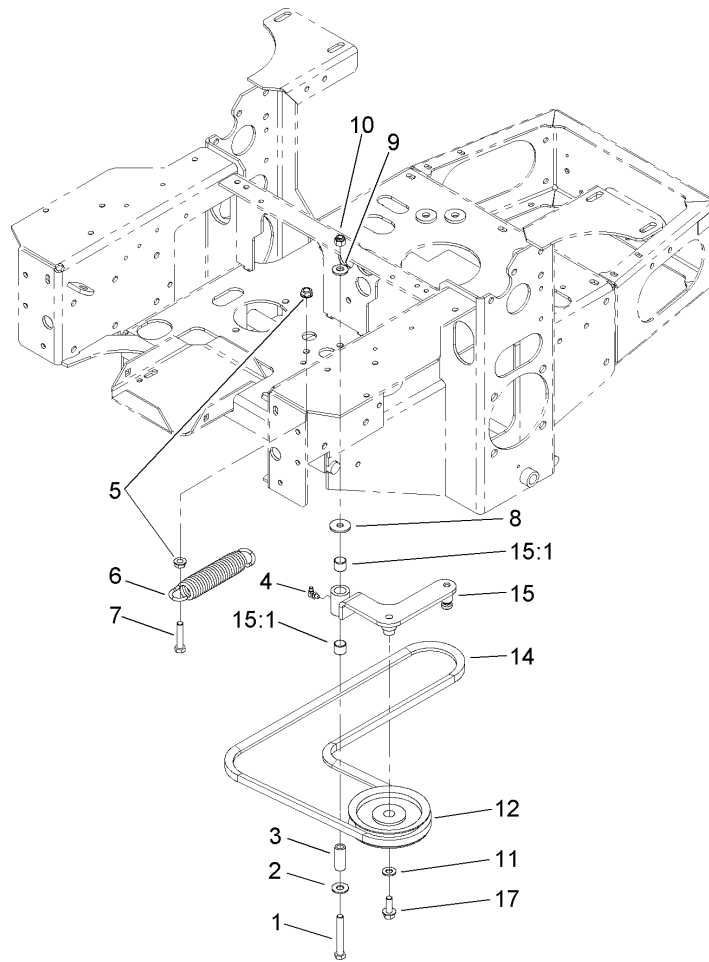

### Pump Idler and Belt Assembly

Ref	Part No.	Qty.	Description
1	323-13	1	Screw-HH
2	3256-4	1	Washer-Flat
3	1-603044	1	Bushing
4	302-40	1	Fitting-Grease
5	3290-357	2	Nut-HHF, Whiz
6	103-4480	1	Spring-Extension
7	323-9	1	Screw-HH
8	63-8410	1	Washer
9	98-5975	1	Washer-Belleville
10	3296-39	1	Nut-Lock, NI
11	3256-24	1	Washer-Flat
12	1-603843	1	Pulley-Idler
14	107-3960	1	Belt
15	103-4482	1	Idler Arm ASM
15:1	103-4681	2	Sleeve-Bearing
17	3234-11	1	Screw-HHF

--	--	--	--

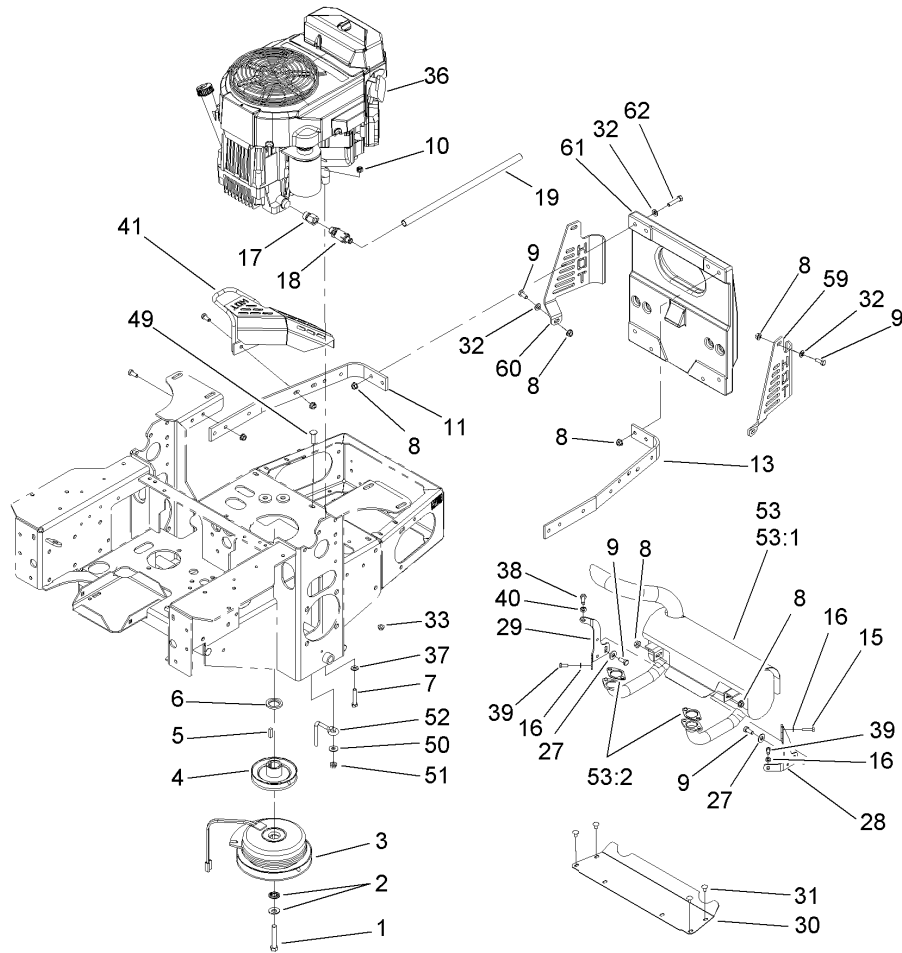

## Engine, Clutch and Muffler Assembly

Ref	Part No.	Qty.	Description
1	3212-12	1	Screw-HH
2	1-603610	2	Washer-Spring
3	109-2916	1	Clutch, Warner Electric
4	103-3913	1	Pulley
5	1-807259	1	Key
6	103-2308	1	Spacer-Crankshaft
7	322-9	4	Screw-HH
8	32128-20	29	Nut-HF
9	322-3	15	Screw-HH
10	3296-29	4	Nut-Lock, NI
11	103-3078-03	1	Strap-Guard, RH
13	103-3164-03	1	Strap-Guard, LH
15	33113-025	1	Screw-HH
16	1-805004	3	Washer-Lock
17	103-1966	1	Adapter
18	92-6877	1	Valve-Drain, Oil
19	106-7022	1	Tube-Drain, Oil
27	3256-3	3	Washer-Flat
28	103-2993-03	1	Bracket-Muffler, LH
29	103-2994-03	1	Bracket-Muffler, RH
30	103-2740-03	1	Deflector-Short
31	3229-10	4	Screw-CARR
32	3256-23	12	Washer-Flat
33	32128-33	4	Nut-HF

Ref	Part No.	Qty.	Description
① 36		1	Engine-Kawasaki, FH680V-As21
37	1-303334	4	Washer-Spring
38	33114-025	1	Screw-HH
39	33113-016	2	Screw-HH
40	1-805005	1	Washer-Lock
41	103-3218-03	1	Guard-Tailpipe
49	3230-3	1	Screw-CARR
50	3256-3	1	Washer-Flat
51	32128-20	1	Nut-HF
52	108-1058	1	Rod-Belt
53	103-3427	1	Muffler Kit
① 53:1		1	Muffler
53:2	1-653313	2	Gasket-Exhaust
59	103-3287-03	1	Guard-Muffler, LH
60	103-3288-03	1	Guard-Muffler, RH
61	107-8421-03	1	Weight-Notched, 60 Lb
62	322-7	8	Screw-HH

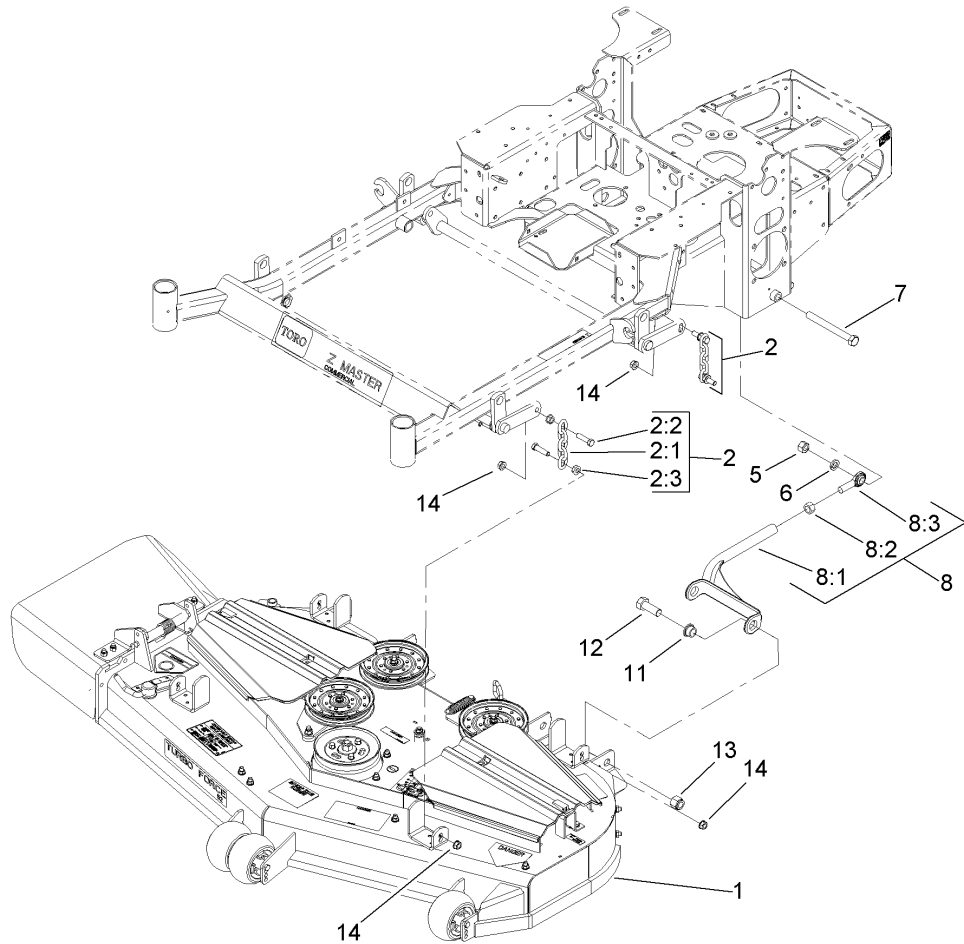

## Deck Connection Assembly

Ref	Part No.	Qty.	Description
1	107-3190	1	Deck ASM
2	103-9792	4	Deck Chain ASM
2:1	1-633447	1	Chain-Lift, Deck
2:2	103-1898	2	Screw-HH
2:3	32128-37	2	Nut-HF
5	3217-11	2	Nut-Hex
6	3253-8	2	Washer-Lock
7	1-800344	2	Screw
8	108-7768	2	Strut ASM
8:1	108-7753-03	1	Strut-Deck, Machined
8:2	3219-6	1	Nut-Hex
8:3	1-633029	1	Balljoint-Spherical
11	93-2877	4	Bushing
12	328-24	4	Screw-HH
13	3296-51	4	Nut-Lock, NI
14	32128-37	8	Nut-HF

--	--	--	--

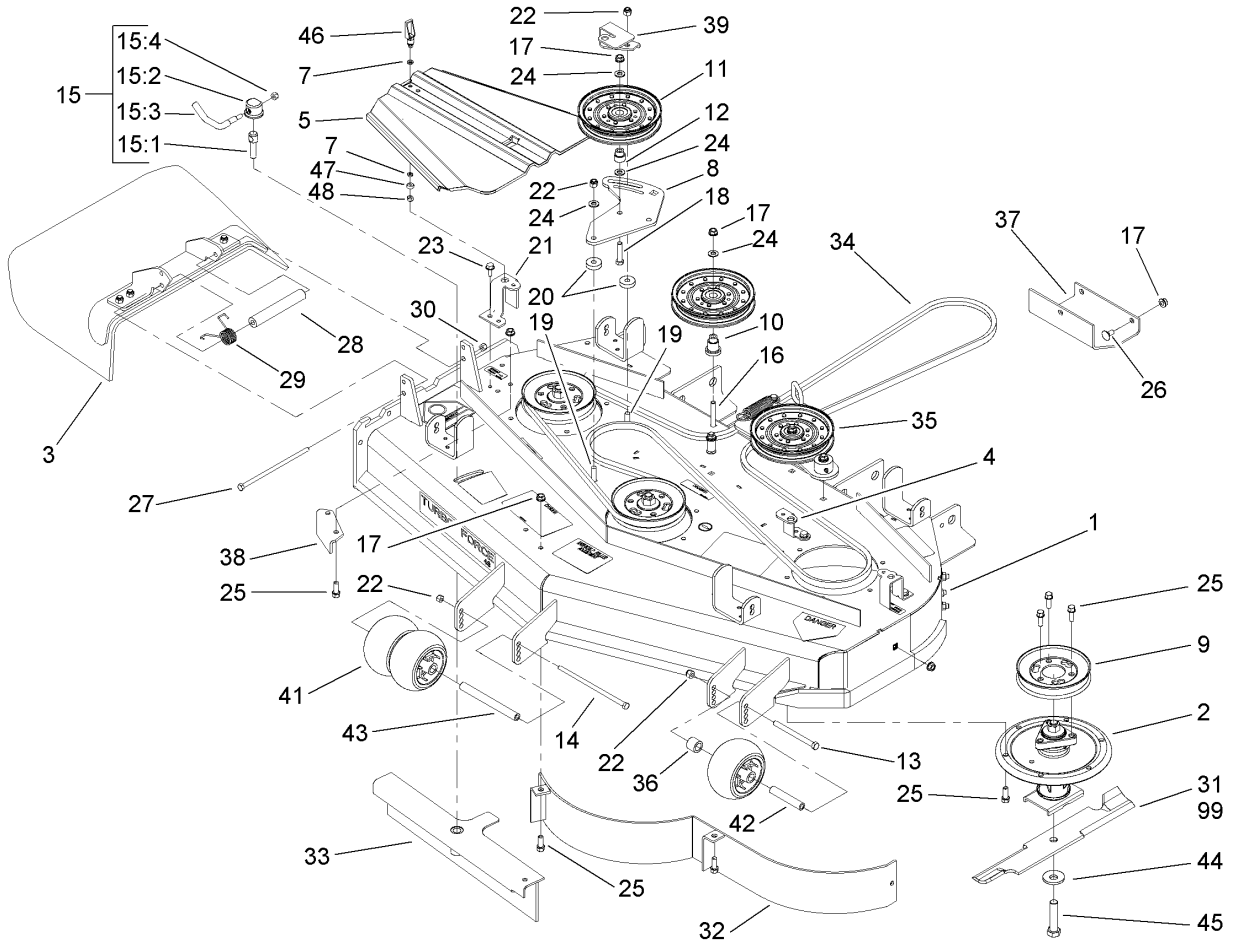

## Deck Assembly No. 107-3190

Ref	Part No.	Qty.	Description
1	107-8515	1	Deck ASM
2	107-8504	3	Spindle ASM
3	108-2792	1	Rubber Deflector ASM
4	108-2177-01	1	Bracket-Cover, Tall
5	107-8536	2	Cover-Belt
7	99-3058	2	Washer
8	107-8516-01	1	Plate-Idler
9	107-1684	3	Pulley
10	106-3214	1	Mount-Pulley
11	1-633109	2	Idler-Flat
12	1-603496	1	Bushing-Idler
13	323-23	1	Screw-HH
14	323-28	1	Screw-HH
15	107-1664	1	Lever ASM
15:1	106-3239	1	Screw-Lock
15:2	107-1644	1	Cap-Lock
15:3	106-3241	1	Lever-Lock
15:4	3296-29	1	Nut-Lock, NI
16	3231-31	1	Screw-CARR
17	3290-357	32	Nut-HHF, Whiz
18	323-9	1	Screw-HH
19	3231-4	2	Screw-CARR
20	105-7788	2	Spacer
21	108-4121-01	2	Bracket-Cover

Ref	Part No.	Qty.	Description
22	3296-39	4	Nut-Lock, NI
23	32144-70	3	Screw-HWHTF
24	3256-24	4	Washer-Flat
25	92-1624	32	Screw
26	3231-1	7	Screw-CARR
27	322-50	1	Screw-HH
28	105-4622	1	Spacer
29	108-4052	1	Spring-Torsion
30	3296-29	1	Nut-Lock, NI
31	107-3192-03	3	Blade-Rotary, 16.5 Inch (High Flow)
32	107-8510-01	1	Baffle ASM
33	107-8506-01	1	Baffle ASM
34	106-7369	1	Belt-V
35		1	Spring Idler ASM
36	98-7913	1	Tube-Spacer
37	107-3166-01	1	Skid
38	107-8541-01	1	Baffle-Discharge
39	108-2228-01	1	Bracket-Cover
41	1-603299	3	Roller-Scalp, Anti
42	98-7912	1	Tube-Spacer
43	98-5967	1	Spacer-Wheel
44	103-0865	3	Washer-Blade Bolt, Heavy
45	103-0862	3	Screw-Cap







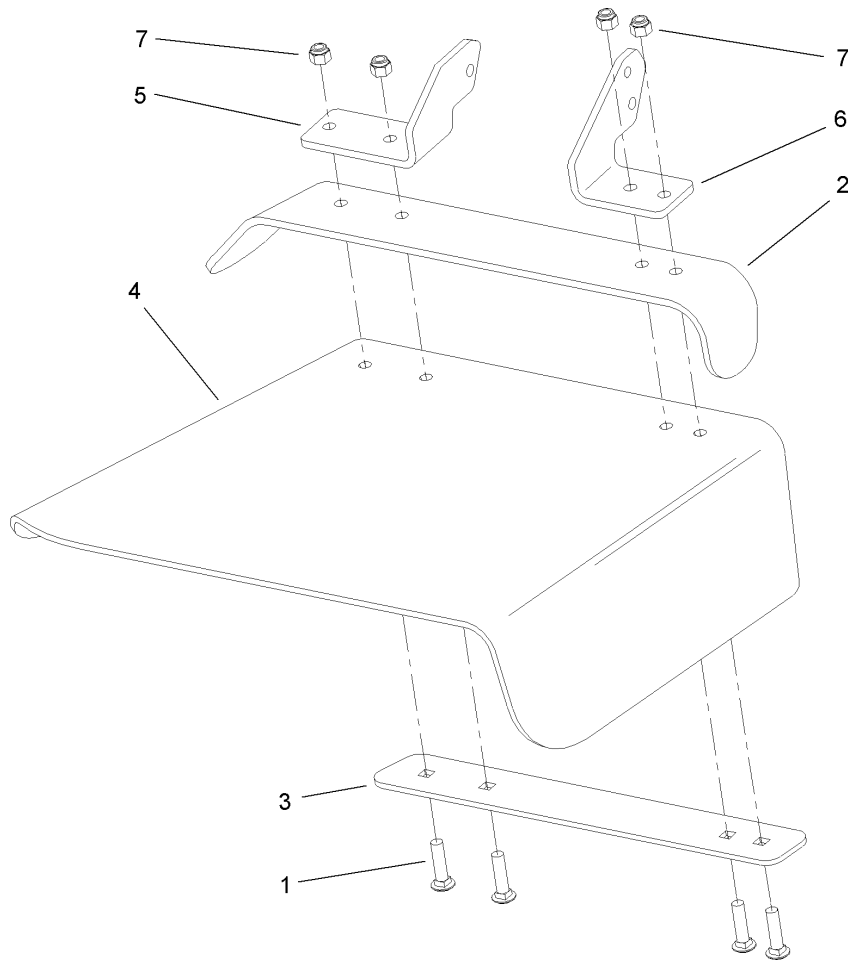

## Rubber Deflector Assembly No. 108-2792

Ref	Part No.	Qty.	Description
1	3231-4	4	Screw-CARR
2	106-3246-01	1	Deflector
3	106-3248-03	1	Strap-Discharge
4	108-5029	1	Deflector-Rubber
5	108-4059-01	1	Plate-Hinge, Rear
6	106-3253-01	1	Plate-Hinge, Front
7	3296-39	4	Nut-Lock, NI

--	--	--	--

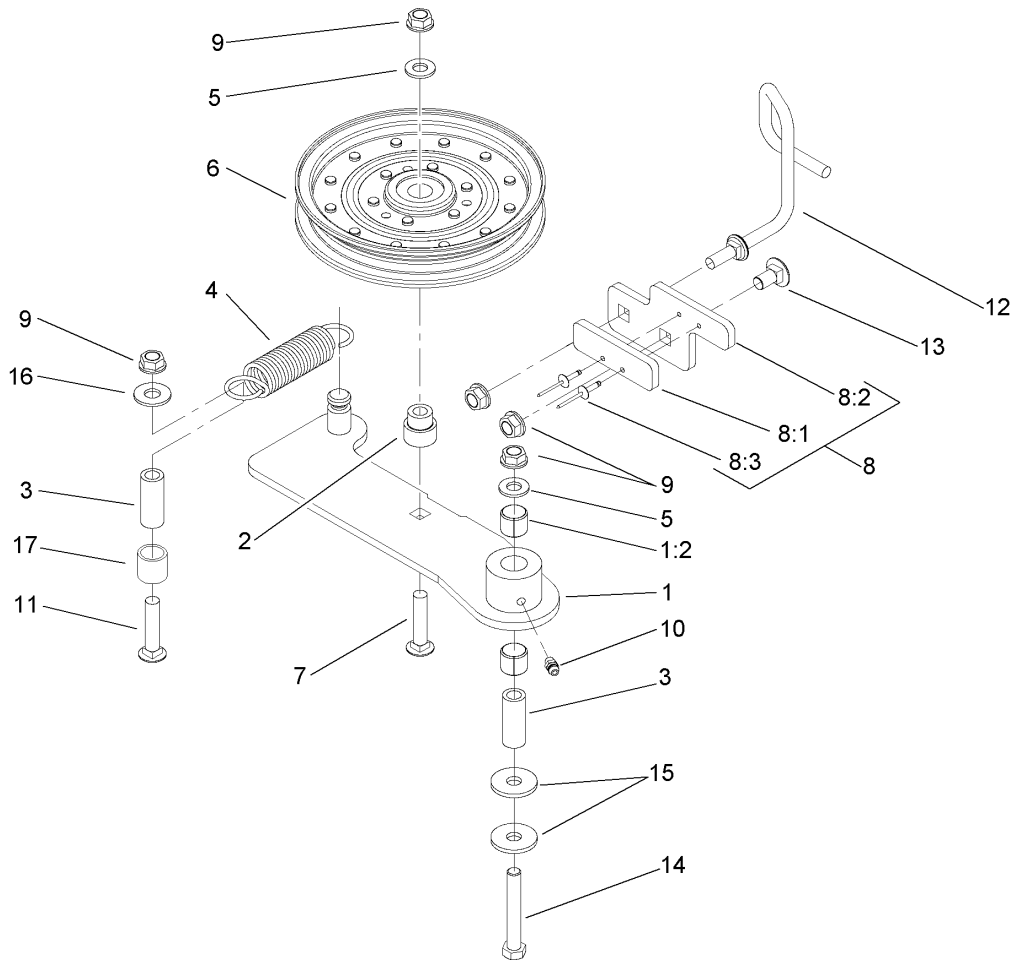

### Idler Assembly

Ref	Part No.	Qty.	Description
1	108-4062	1	Idler Arm ASM
1:2	103-4681	2	Sleeve-Bearing
2	1-603496	1	Bushing-Idler
3	1-603044	2	Bushing
4	108-4056	1	Spring-Extension
5	3256-24	2	Washer-Flat
6	1-633109	1	Idler-Flat
7	3231-6	1	Screw-CARR
8		1	Stop Pad ASM
8:1	106-3229	1	Pad-Bumper
8:2	107-1697-01	1	Plate-Stop
8:3	3269-24	2	Rivet
9	3290-357	5	Nut-HHF, Whiz
10	302-5	1	Fitting-Grease
11	3231-31	1	Screw-CARR
12	108-4072	1	Guide-Belt
13	3231-1	1	Screw-CARR
14	323-12	1	Screw-HH
15	2844	2	Washer
16	3256-4	1	Washer-Flat
17	108-4063	1	Spacer-Rubber

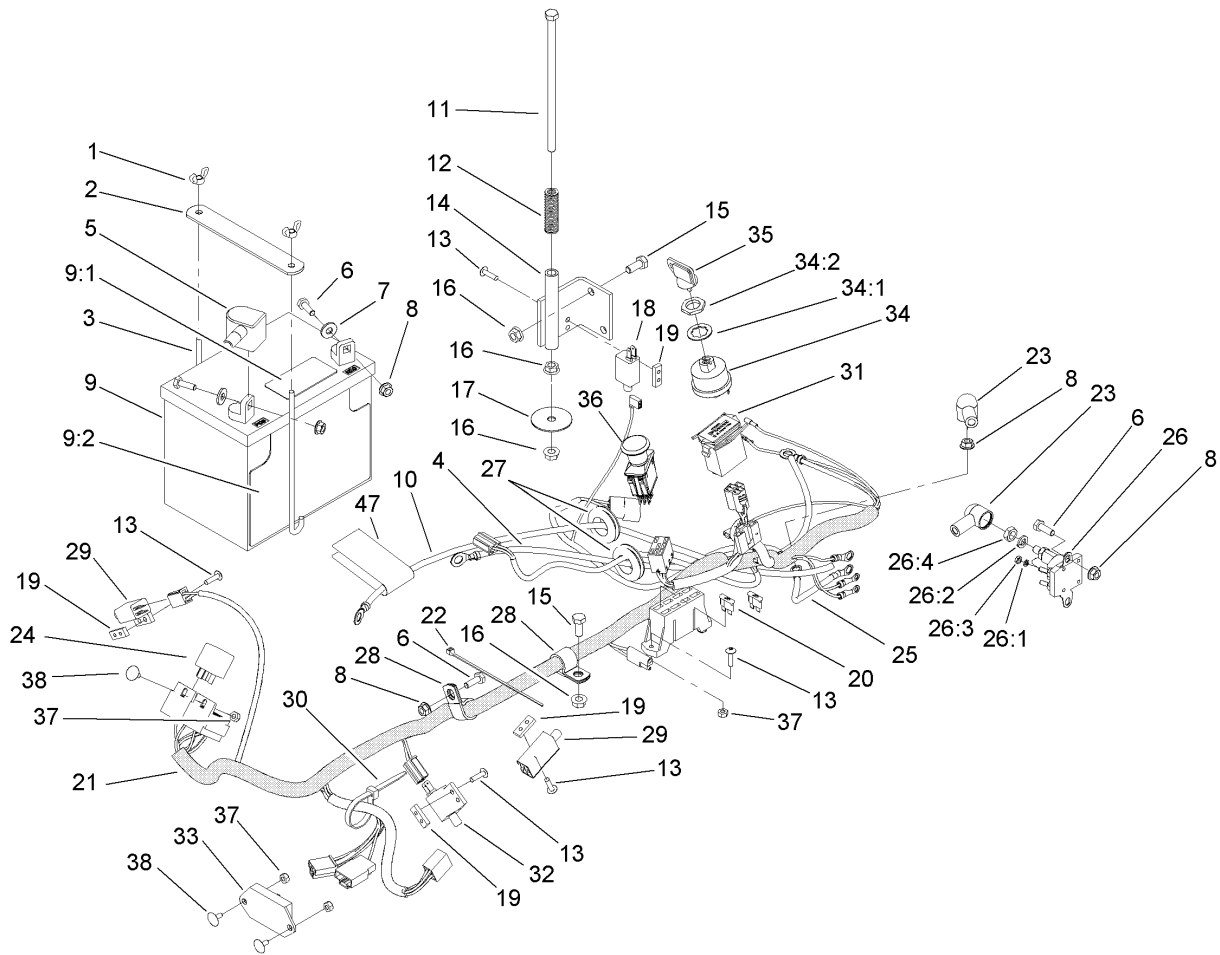
## Electrical System Assembly

Ref	Part No.	Qty.	Description
1	1-543792	2	Wingnut
2	107-9277-03	1	Strap-Holddown, Battery
3	1-633651	2	Bolt-Holddown
4	103-0705	1	Cable-Ground, Negative
5	1-543391	1	Insulator-Battery
6	321-4	5	Screw-HH
7	3256-2	2	Washer-Flat
8	32128-33	6	Nut-HF
9	105-1692	1	Battery
9:1	104-4163	1	Decal-Battery
9:2	104-4164	1	Decal-Battery
10	103-0707	1	Cable-Battery, Positive
11	1-800282	1	Screw-HH
12	1-523415	1	Spring-Switch, Seat
13	1-803075	10	Screw-Head, Truss
14	1-652072-03	1	Bracket-Switch, Seat
15	322-3	3	Screw-HH
16	32128-20	5	Nut-HF
17	1-653036	1	Washer
18	1-513152	1	Switch-Closed, Normally
19	1-633181	4	Plate-Tapped
20	1-816001	2	Fuse-Blade Type, 20 Amp
21	110-0318	1	Harness-Electrical
22	1-303287	3	Tie-Plastic

Ref	Part No.	Qty.	Description
23	1-543393	3	Insulator-Solenoid
24	1-643275	2	Relay
25	1-633306	1	Cable-Starter, Positive
26	1-513075	1	Switch-Solenoid
26:1	3253-17	2	Washer-Lock
26:2	3253-4	2	Washer-Lock
26:3	3219-4	2	Nut-Hex
26:4	3220-2	2	Nut-Jam
27	1-543286	2	Grommet
28	1-633396	2	Clip-Loom
29	1-513051	2	Switch-Open, Normally
30	1-303335	4	Tie-Plastic
31	1-513374	1	Meter-Hour
32	1-633111	1	Switch
33	100-6186	1	Module-Delay, Seat
34	103-0206	1	Switch-Starting, Key
34:1	3254-5	1	Washer-Tooth
34:2	218-461	1	Nut-HH
35	63-8360	2	Key-Ignition
36	103-5221	1	Switch-PTO
37	3296-2	6	Nut-Lock
38	1-807513	4	Bolt-CARR
47	107-9309	1	Decal-Instructions, Charging

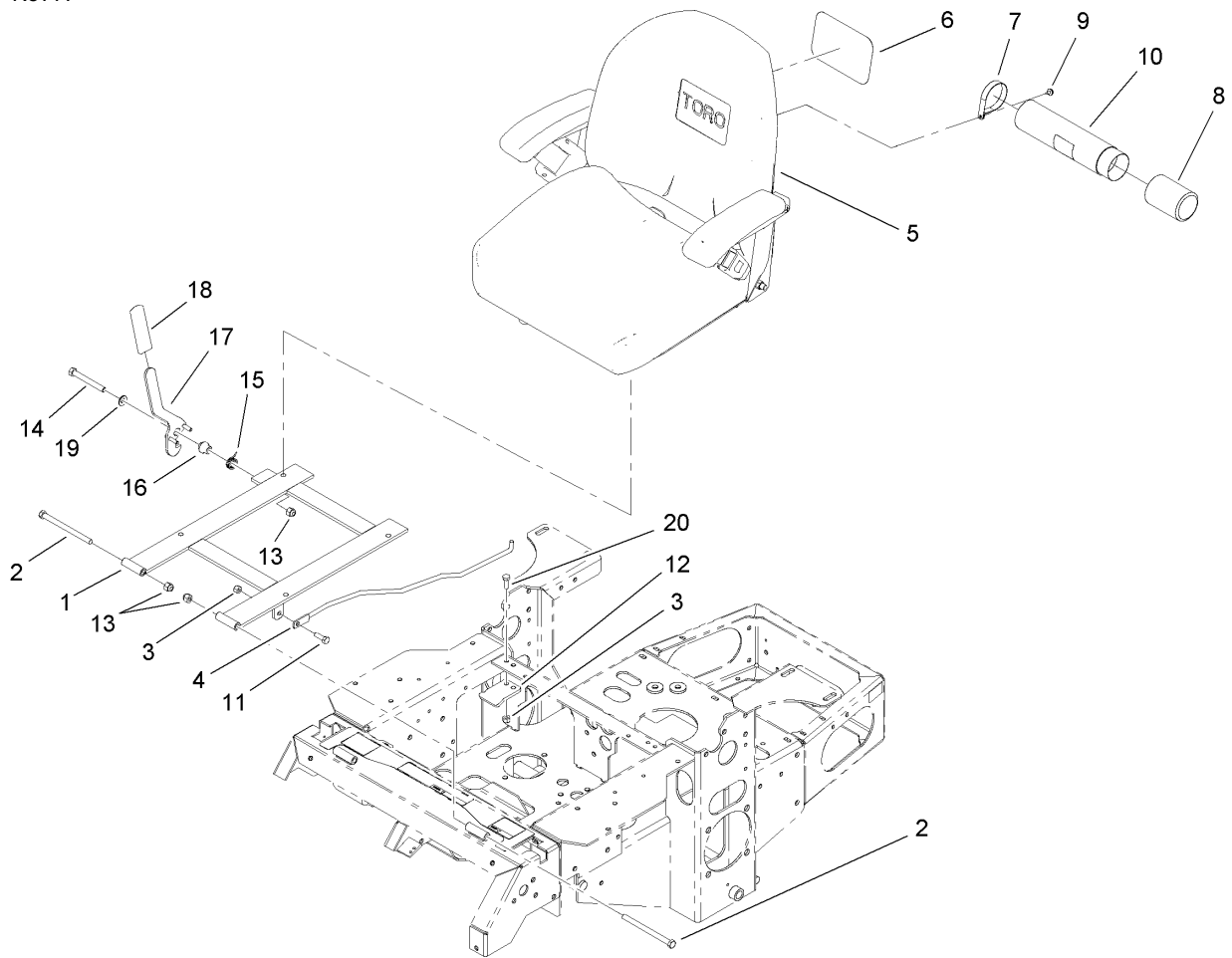

## Seat and Bracket Assembly

Ref	Part No.	Qty.	Description
1	107-3052-03	1	Seat Support Frame ASM
2	323-39	2	Screw-HH
3	3296-29	3	Nut-Lock, NI
4	103-1731	1	Rod-Retainer, Seat
5	110-0446	1	Seat ASM
6	99-4693	1	Decal
7	2412-120	2	R-Clamp
8	104-7048	1	Cap-Housing
9	32104-76	2	Screw
10	104-7050	1	Housing-Manual
11	322-5	1	Screw-HH
12	103-5961	1	Catch-Latch, Seat
13	3296-39	3	Nut-Lock, NI
14	323-20	1	Screw-HH
15	107-0076	1	Spring-Torsion
16	107-0075	1	Bushing-Latch, Seat
17	107-3083	1	Latch ASM
18	103-4434	1	Grip-Lever
19	3256-24	1	Washer-Flat
20	322-4	2	Screw-HH





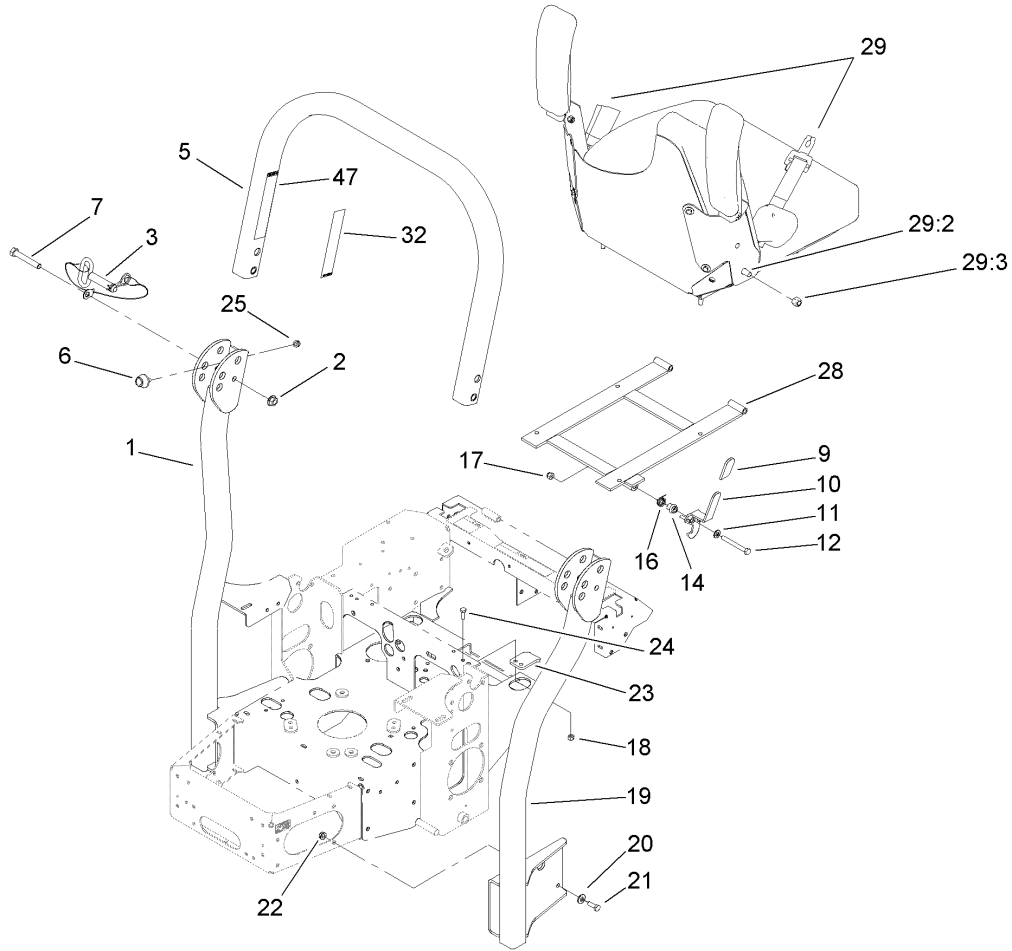

## Roll-Over Protection System Assembly No. 107-8093

Ref	Part No.	Qty.	Description
❶1		1	LH Tube Support ASM
2	32128-23	2	Nut-HF
3	103-4553	2	ROPS Fold Pin ASM
❶5		1	Upper Tube ASM
6	109-2365	2	Bumper-Rubber (W/Stud)
7	325-13	2	Screw-HH
9	103-4434	1	Grip-Lever
10	107-3083	1	Latch ASM
11	3256-24	1	Washer-Flat
12	323-20	1	Screw-HH
14	107-0075	1	Bushing-Latch, Seat
16	107-0076	1	Spring-Torsion
17	3296-39	1	Nut-Lock, NI
18	3296-29	2	Nut-Lock, NI
❶19		1	RH Tube Support ASM
20	98-5975	8	Washer-Belleville
21	323-6	8	Screw-HH
22	3290-357	8	Nut-HHF, Whiz
23	107-3059	1	Catch-Latch, Seat
24	322-4	2	Screw-HH
25	3296-73	2	Nut-Lock, NI
28	107-3052-03	1	Seat Support Frame ASM
29	110-0883	1	Retractable Seatbelt Kit
29:2	3212-4	2	Screw-HH

Ref	Part No.	Qty.	Description
29:3	3296-7	2	Nut-Lock
32	107-3069	1	Decal-Warning, Folding ROPS (Ce)
47	107-2102	1	Decal-Warning, Folding ROPS

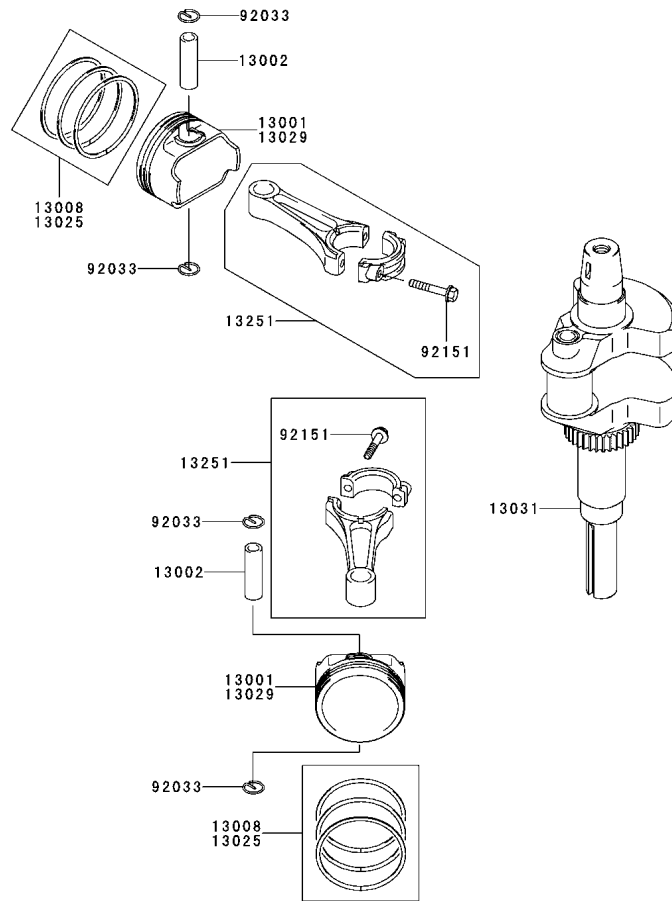

## Piston / Crankshaft Assembly Kawasaki FH680V-AS21

Ref	Part No.	Qty.	Description				
②13001	13001-7007	2	Piston-Engine				
②13002	13002-7001	2	Pin-Piston				
②13008	13008-6058	2	Ring Set-Piston				
②13025	13025-7002	0	Ring-Set, Piston (L,0.50)				
②13029	13029-7003	0	Piston-Engine (L,0.50)				
②13031	13031-7023	1	Crankshaft-Comp				
②13251	13251-7005	2	Connecting Rod ASM				
②92033	92033-7005	4	Ring-Snap				
②92151	92151-7017	4	Bolt (6X35)				



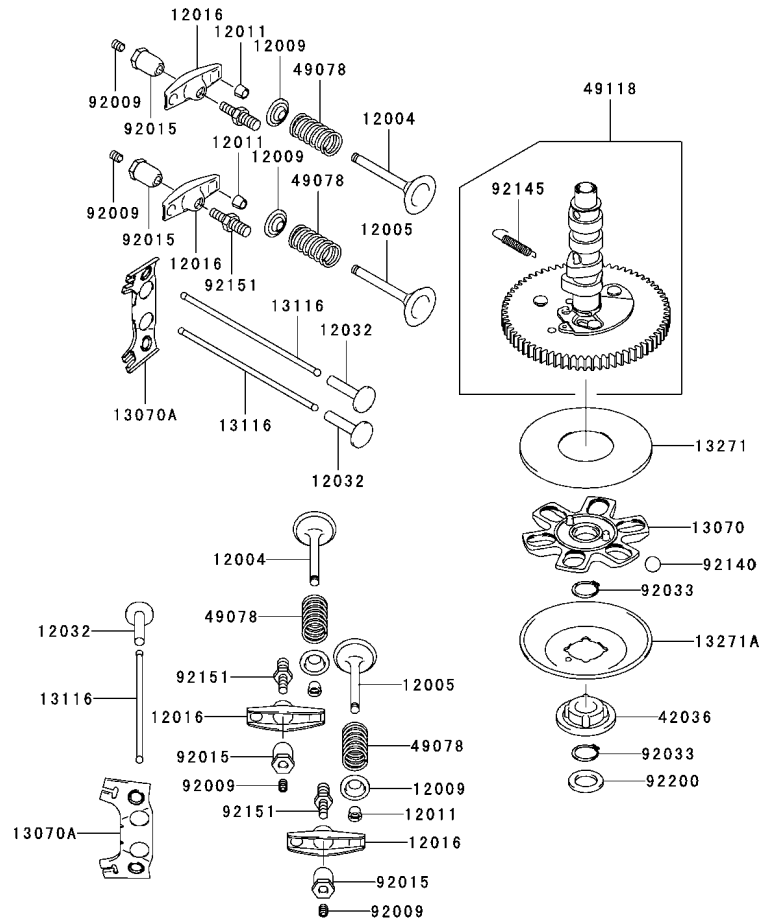

## Valve / Camshaft Assembly Kawasaki FH680V-AS21

Ref	Part No.	Qty.	Description
②12004	12004-7002	2	Valve-Intake
②12005	12005-7002	2	Valve-Exhaust
②12009	12009-7001	4	Retainer-Spring, Valve
②12011	12011-2056	8	Collet
②12016	12016-7006	4	Arm-Rocker
②12032	12032-7001	4	Tappet
②13070	13070-7004	1	Guide
②13070A	13070-7007	2	Guide
②13116	13116-7002	4	Rod-Push
②13271	13270-7007	1	Plate
②13271A	13271-7021	1	Plate-Governor
②42036	42036-7001	1	Sleeve
②49078	49078-7002	4	Spring-Valve, Engine
②49118	49118-7007	1	Camshaft
②92009	92009-2341	4	Screw
②92015	92015-2253	4	Nut
②92033	92033-7001	2	Ring-Snap
②92140	92140-7002	6	Ball
②92145	92145-7001	1	Spring
②92151	92151-7019	4	Bolt
②92200	92200-7001	1	Washer

--	--	--	--



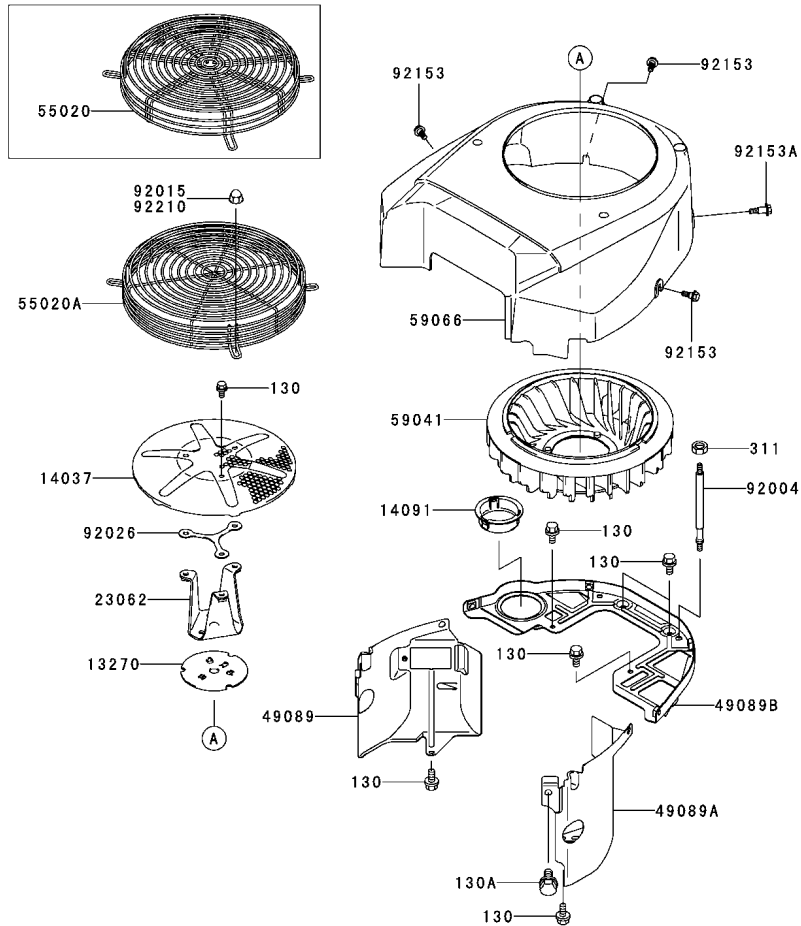

## Cooling Equipment Assembly Kawasaki FH680V-AS21

Ref	Part No.	Qty.	Description
②13270	13270-7007	1	Plate
②14037	14037-7008-9H	1	Screen
②14091	14091-7002	1	Cover
②23062	23062-7005	1	Bracket-Comp
②49089	49089-7004	1	Shroud-Engine
②49089A	49089-7005	1	Shroud-Engine
②49089B	49089-7030	1	Shroud-Engine
②55020	55020-7002	1	Guard
②55020A	55020-7007	1	Guard
②59041	59041-7003	1	Fan
②59066	59066-7004	1	Housing-Fan
②92004	92004-7006	2	Stud
②92015	92015-1170	4	Nut
②92026	92026-7007	0	Spacer
②92153	92153-7007	3	Bolt
②92153A	92153-7008	1	Bolt
②92210	92210-0003	4	Nut
②130	130B0612	9	Bolt-Flanged
②130A	130B0816	1	Bolt-Flanged
②311	311B0600	2	Nut-Hex

--	--	--	--

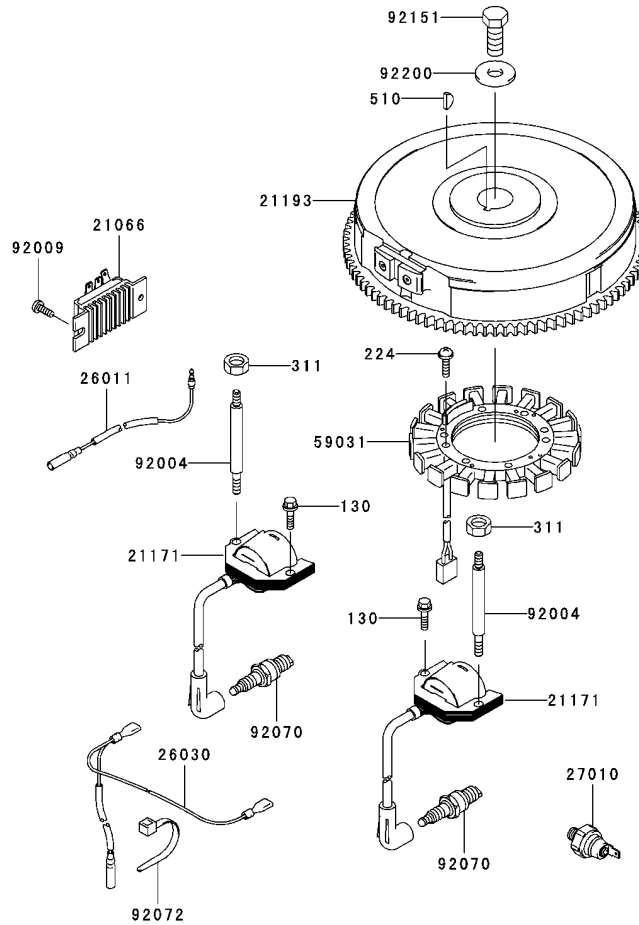

## Electric Equipment Assembly Kawasaki FH680V-AS21

Ref	Part No.	Qty.	Description
21066	21066-7006	1	Regulator-Voltage
21171	21171-7007	2	Coil-ASM-Ignition
21193	21193-7019	1	Flywheel-Assy
26011	26011-7008	1	Wire-Lead
26030	26030-7002	1	Harness
27010	27010-7001	1	Switch
59031	59031-7001	1	Coil-Charging
92004	92004-7009	2	Stud
92009	92009-2308	1	Screw
92070	92070-7004	2	Plug-Spark,Bpr4Es(Ngk), Solid
92072	92072-7003	2	Band
92151	92151-2097	1	Bolt (12X30)
92200	92200-7002	1	Washer
130	130B0620	2	Bolt-Flanged
224	224B0520	4	Screw-Pan
311	311B0600	2	Nut-Hex
510	510A5100	1	Key-Woodruff

--	--	--	--

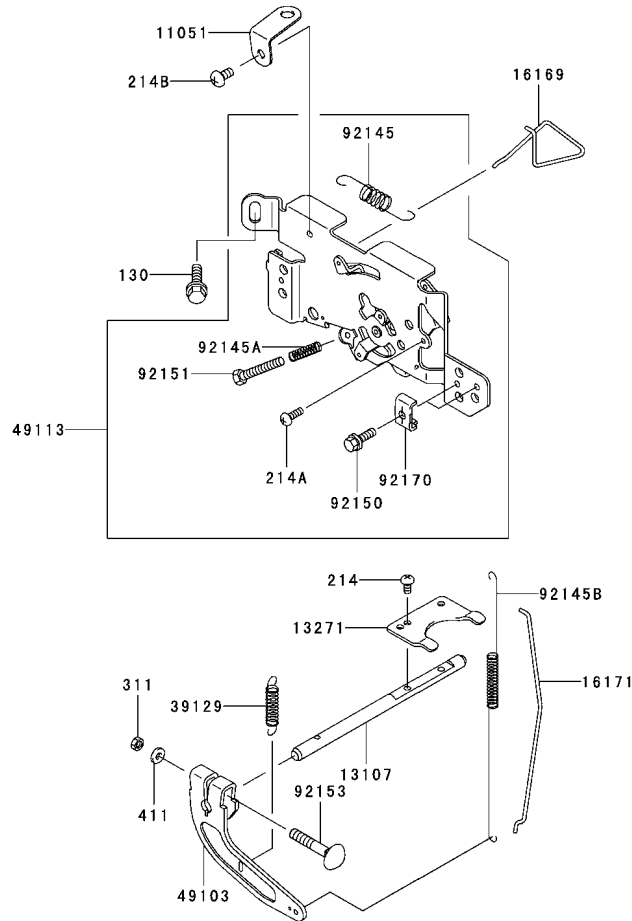

## Control Equipment Assembly Kawasaki FH680V-AS21

Ref	Part No.	Qty.	Description
②11051	11051-7008	1	Bracket
②13107	13107-7013	1	Shaft
②13271	13271-7018	1	Plate
②16169	16169-7006	1	Link-Choke
②16171	16171-7004	1	Link
②39129	39129-7004	1	Spring-Governor
②49103	49103-7004	1	Arm-Governor
②49113	49113-7017	1	Panel-Comp-Control
②92145	92145-7004	1	Spring
②92145A	92145-7005	1	Spring
②92145B	92145-7009	1	Spring
②92150	92150-2182	2	Bolt (5X18)
②92151	92151-7014	1	Bolt (5X30)
②92153	92153-7005	1	Bolt (6X35)
②92170	92170-7001	2	Clamp
②130	130B0612	2	Bolt-Flanged
②214	214B0408	2	Screw-Pan
②214A	214B0412	1	Screw-Pan
②214B	214B0510	1	Screw-Pan
②311	311B0600	1	Nut-Hex
②411	411b0600	1	Washer-Plain

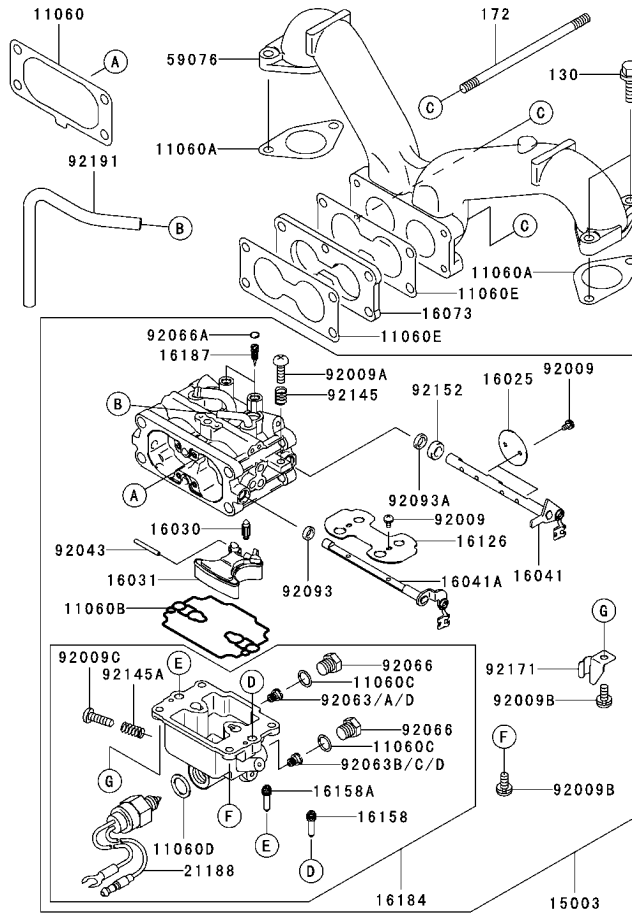

## Carburetor Assembly Kawasaki FH680V-AS21

Ref	Part No.	Qty.	Description
②11060	11060-7009	1	Gasket, Air Filter
②11060A	11060-7011	2	Gasket
②11060B	11060-7018	1	Gasket-Chamber, Float
②11060C	11060-7019	2	Gasket-Plug, Main
②11060D	11060-7020	1	Gasket-Solenoid
②11060E	11060-7024	2	Gasket-Carburetor
②15003	15003-7073	1	Carburetor-Assy
②16025	16025-7003	2	Valve-Throttle
②16030	16030-7002	1	Valve-Float
②16031	16031-7001	1	Float
②16041	16041-7004	1	Shaft-Carburetor Throttle
②16041A	16041-7007	1	Shaft-Carburetor, Choke
②16073	16073-7005	1	Insulator
②16126	16126-7004	1	Valve-Choke
②16158	16158-7007	1	Jet-Slow, No.56
②16158A	16158-7008	1	Jet-Slow, No.42
②16184	16184-7010	1	Chamber-Assy-Float
②16187	16187-7002	2	Needle-Jet
②21188	21188-7001	1	Solenoid
②59076	59076-7002	1	Manifold-Intake
②92009	92009-7003	6	Screw
②92009A	92009-7004	1	Screw
②92009B	92009-7005	4	Screw
②92009C	92009-7006	1	Screw-Drain

Ref	Part No.	Qty.	Description
②92043	92043-7004	1	Pin-Float
②92063	92063-7017	1	Jet-Main, No.133
②92063A	92063-7018	1	Jet-Main, No.130
②92063B	92063-7019	1	Jet-Main, No.139
②92063C	92063-7020	1	Jet-Main, No.134
②92063D	92063-7038	2	Jet-Main, No.114
②92066	92066-7008	2	Plug-Jet, Main
②92066A	92066-7009	2	Plug, Extension
②92093	92093-7001	1	Seal
②92093A	92093-7002	1	Seal
②92145	92145-7010	1	Spring
②92145A	92145-7011	1	Spring
②92152	92152-7001	1	Collar
②92171	92171-7001	1	Clamp
②92191	92191-7023	1	Tube
②130	130B0620	4	Bolt-Flanged
②172	172G06105	2	Bolt-Stud









# Attachments and Accessories

For 74417 - Z453 Z Master, With 48in TURBO FORCE Side Discharge Mower

Product Name	Model/Part
Deck Lift Assist Kit .....	106-9749
Striping Kit .....	107-1630
Deluxe Suspension Seat .....	107-1891
Suspension Kit for Standard Seat .....	107-1892
Z Stand Kit .....	107-8599
Recycler Kit .....	108-2209
Mower Deck Lift Assist Kit .....	108-4090
Bagging Enhancement Kit .....	108-4091
Blade-Hi Flow, 16.5 Inch (6 Pack) .....	110-0414
Blade-Lo Flow, 16.5 Inch (6 Pack) .....	110-0415
Blade-Recycler, 16.5 Inch (6 Pack) .....	110-0416
Blade-Atomic, 16.5 Inch (6 Pack) .....	110-0417
Blade-Mid Flow, 16.5 Inch (6 Pack) .....	110-0418
Sunshade-Bimini .....	110-5726
Twin Bagger .....	78507
DFS Vac Collection System .....	78510
48 Inch Finishing Kit .....	78511
Hitch Kit .....	99-8924

# NOTES

# NOTES

# NOTES

