



## Z597-D Z Master<sup>®</sup> With 72in TURBO FORCE<sup>®</sup> Side Discharge Mower

Model No. 74269 - 270000001 and up.

### Parts Catalog

---

#### Ordering Replacement Parts

To order replacement parts, please supply the part number, the quantity, and the description of each part desired.

#### Understanding Reference Numbers

Each identified part in an illustration has a reference number. The reference number for a part also appears in the parts list, along with other information about the part.

This catalog uses two special reference number formats, one to indicate parts in a service assembly and another to indicate the quantity of a given part in an illustration.

#### Service Assembly Reference Numbers

Parts in service assemblies have reference numbers in the form a:b. The a represents the reference number of the entire service assembly and the b represents a sequential number unique to each part within the service assembly.

For example, a wheel assembly might be identified by reference number 6, the tire by 6:1, the valve by 6:2, and the wheel by 6:3. When you order the assembly identified by reference number 6, you receive all parts identified by reference numbers 6:1, 6:2, and 6:3. However, you may also order any part individually. Reference numbers of this type appear in illustrations and in part lists.

#### Reference Numbers Indicating Quantity

In an illustration, if a reference number indicates more than one part, the reference number has the form nX y. The n represents the quantity of the part, the X is the multiplication symbol, and the y represents the reference number.

For example, in an illustration, the reference number 2X 37 means that two of the parts identified by reference number 37 are indicated.

# Contents

Description	Page	Description	Page
Front Frame Assembly	..... 3	Hood Assembly	..... 25
Caster and Z Stand Assembly	..... 5	Deck Connection Assembly	..... 26
Engine Frame, Console and Floor Pan Assembly	..... 6	Deck Assembly	..... 27
Seat and Roll-Over Protection System Assembly	..... 7	Deck Decal Assembly No. 107-7677	..... 29
Deluxe Seat Assembly No. 110-0838	..... 8	Spindle Assembly No. 110-3933	..... 30
Roll-Over Protection System Assembly No. 106-7437	..... 9	Lever Assembly No. 107-1664	..... 31
Wheel and Brake Assembly	..... 10	Rubber Deflector Assembly No. 108-2792	..... 32
Motion Control Assembly	..... 11	Electrical Assembly	..... 33
RH Motion Control Assembly No. 109-3978	..... 12	Cylinder Assembly	..... 35
LH Motion Control Assembly No. 109-3979	..... 13	Crankshaft Assembly	..... 36
Engine Mount Assembly	..... 14	Cylinder Head Assembly	..... 37
Wheel Pump Drive Assembly	..... 15	Injection Pump Assembly	..... 38
Deck Belt Drive Assembly	..... 16	Camshaft Assembly	..... 39
Cooling Pump Drive Assembly	..... 17	Oil Pan Assembly	..... 40
Hydraulic System Assembly	..... 18	Gear Cover Assembly	..... 41
Tank and Fuel Line Assembly	..... 20	Gear Housing Assembly	..... 42
Front and Rear Engine Cover Assembly	..... 22	Water Pump Assembly	..... 43
Cooling System Assembly	..... 24	Manifold Assembly	..... 44
		Starter Motor and Alternator Assembly	..... 45
		Gasket Assembly	..... 46
		Attachments and Accessories List	..... 47

## Part Description Abbreviations

Part descriptions in this catalog may include the following abbreviations.

AR. .... as required	HYD. .... hydraulic
ASM. .... assembly	LH. .... left hand
BBC. .... blade brake clutch	NI. .... nylon insert
CARR. .... carriage	NPTF. .... national pipe thread fine
DEG. .... degrees	PFH. .... phillips flat head
EXT. .... external	PPH. .... phillips pan head
FH. .... flat head	PPHTF. .... phillips pan head thread forming
GA. .... gauge	PRH. .... phillips round head
HD. .... heavy-duty	PTH. .... phillips truss head
HF. .... hex flange	PTO. .... power-take-off
HH. .... hex head	RH. .... right hand
HHF. .... hex head flange	ROPS. .... roll-over protection system
HHFTF. .... hex head flange thread forming	SFH. .... slotted fillister head
HJ. .... hex jam	SHH. .... slotted hex head
HLH. .... hex lag head	SHWH. .... slotted hex washer head
HOC. .... height-of-cut	SPH. .... slotted pan head
HSBH. .... hex socket button head	SQH. .... square head
HSFH. .... hex socket flat head	SRH. .... slotted round head
HSH. .... hex socket head	STD. .... standard
HWH. .... hex washer head	TAP. .... self tapping
HWHTF. .... hex washer head thread forming	TTH. .... torx truss head

## Footnotes

❶ Not illustrated

❷ Not serviced separately

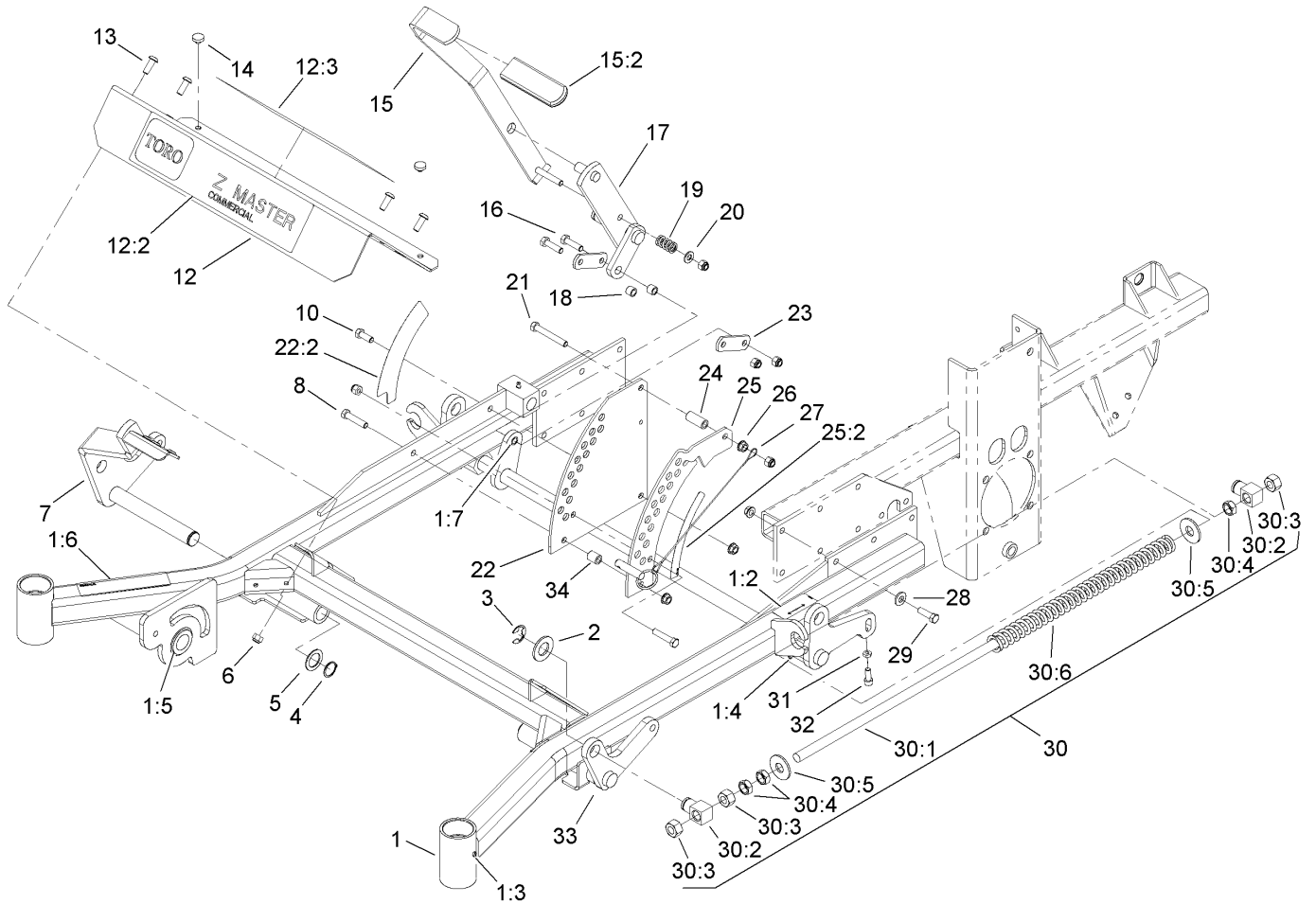

## Front Frame Assembly

Ref	Part No.	Qty.	Description
1	106-8999	1	Frame ASM
1:2	107-1857	1	Decal-Brake, Parking
1:3	1-811010	2	Plug
1:4	302-19	5	Fitting-Grease
1:5	94-1291	2	Bushing
1:6	104-7759	1	Decal-Warning
1:7	103-1918	1	Bushing
2	3256-29	4	Washer-Flat
3	32151-103	5	Ring-Snap
4	32151-29	2	Ring-Retaining
5	1-523157	2	Washer-Spacer, 14 GA
6	3296-39	9	Nut-Lock, NI
7	108-7786-01	1	RH Front Deck Lift ASM
8	323-9	2	Screw-HH
10	323-6	1	Screw-HH
12	106-9981	1	Front Floorpan ASM
12:2	106-7451	1	Decal
12:3	107-2112	1	Decal-Warning
13	3274-94	4	Screw-HSBH
14	1-513658	2	Bumper
15	103-2084	1	Lift Lever/Grip ASM
15:2	1-633295	1	Grip-Lever, Lift
16	323-29	2	Screw-HH
17	103-2064-03	1	Arm-Lift, Deck

Ref	Part No.	Qty.	Description
18	103-1918	2	Bushing
19	1-633325	1	Spring-Compression
20	3256-24	1	Washer-Flat
21	323-13	1	Screw-HH
22	110-0833	1	Outer Deck Lift Plate ASM
22:2	107-1860	1	Decal-Height, Deck
23	1-633068	2	Arm-Lift, Deck
24	1-633082	1	Bushing-Lever, Lift
25	110-0834	1	Inner Deck Lift Plate ASM
25:2	107-1861	1	Decal-Height, Deck
26	3290-357	15	Nut-HHF, Whiz
27	106-9951	1	Hitch Pin ASM
28	98-5975	12	Washer-Belleville
29	323-7	12	Screw-HH
30		2	Front Frame Spring ASM
30:1	1-633096	1	Rod-Lift, Deck
30:2	1-633441	2	Swivel-Deck Mount, Rear
30:3	3217-11	3	Nut-Hex
30:4	3218-6	3	Nut-Jam
30:5	3256-7	2	Washer-Flat
30:6	1-643015	1	Spring-Support, Deck
31	3218-2	2	Nut-Jam
32	3274-18	2	Screw-HSH
33	106-8984-01	1	LH Deck Lift ASM



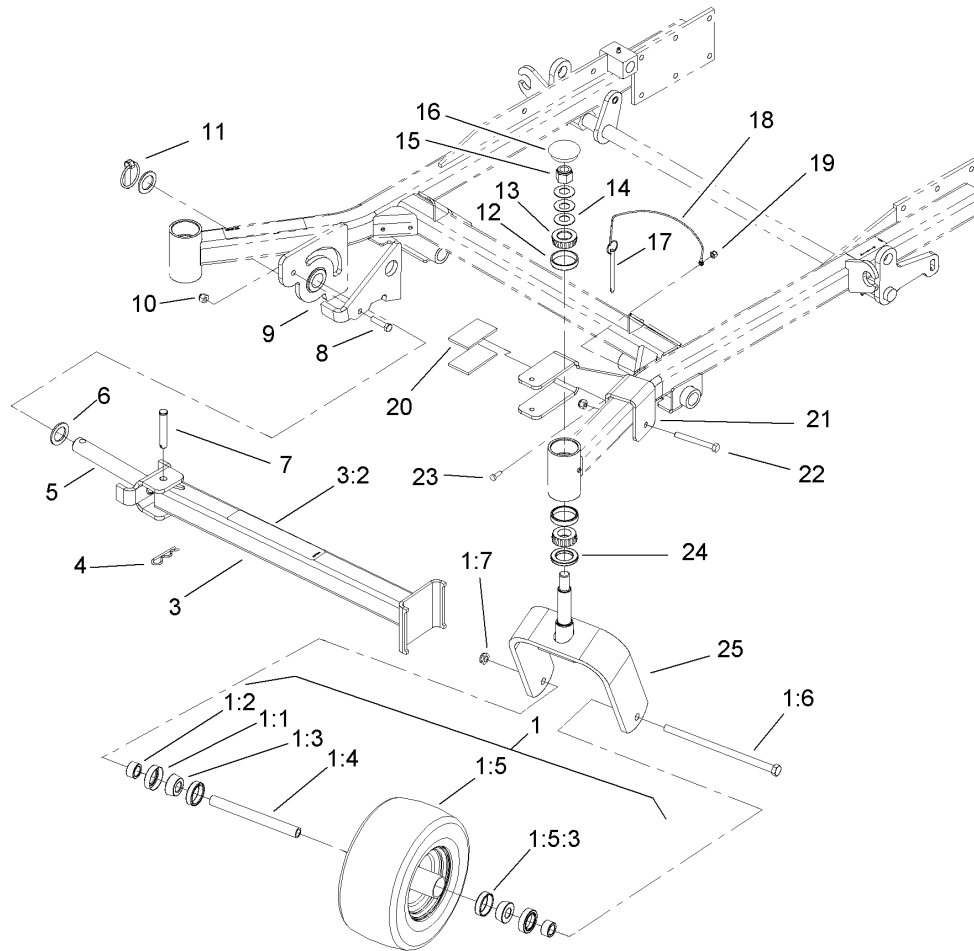

## Caster and Z Stand Assembly

Ref	Part No.	Qty.	Description
1	110-5746	2	Castor Wheel ASM
1:1	1-633580	2	Seal-Bearing
1:2	1-633581	2	Spacer-Bearing
1:3	1-633585	2	Bearing-Cone, Taper
1:4	1-633959	1	Spacer-Caster, Front
1:5	110-5744	1	Wheel And Tire ASM (Semi-Pneumatic)
1:5:3	1-633584	1	Bearing-Cup
1:6	325-24	1	Screw-HH
1:7	3296-45	1	Nut-Lock, NI
3	107-1874	1	Leg ASM
3:2	106-7464	1	Decal-Z Stand
4	3290-355	1	Pin-Hair
5	100-9692-01	1	Pivot Pin ASM
6	3-6781	2	Washer-Thrust
7	283-55	1	Pin-Clevis
8	323-8	1	Screw-HH
9	100-9686-01	1	Bracket-Latch
10	3296-39	2	Nut-Lock, NI
11	283-71	1	Pin-Lynch
12	254-72	4	Bearing-Cup, Tapered
13	254-94	4	Bearing-Cone, Tapered
14	1-633508	6	Washer-Bellville
15	3296-51	2	Nut-Lock, NI

Ref	Part No.	Qty.	Description
16	103-4882	2	Cap-Grease
17	105-1647	1	Pin-Hitch, Cotterless
18	100-9385	1	Lanyard-Nylon
19	3296-42	1	Nut-Lock, NI
20	100-6547	2	Cushion-Rubber
21	100-6542-01	1	Bracket-Cradle
22	323-20	1	Screw-HH
23	321-4	1	Screw-HH
24	1-543511	2	Seal-Grease
25	103-1474-01	2	Fork-Caster

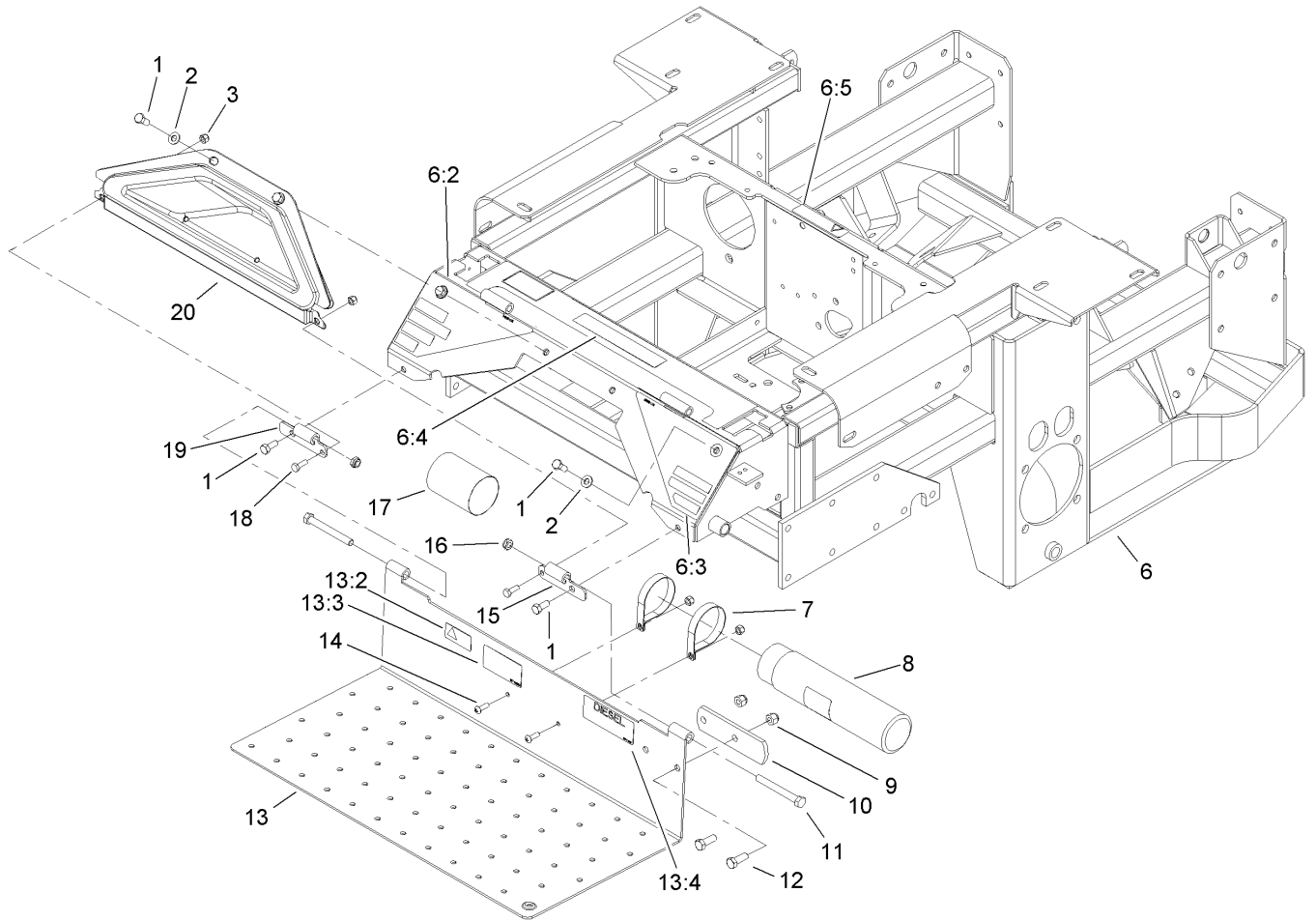

## Engine Frame, Console and Floor Pan Assembly

Ref	Part No.	Qty.	Description
1	322-43	6	Screw-HH
2	3256-70	4	Washer-Flat
3	3296-42	4	Nut-Lock, NI
6	110-8722	1	Main Frame ASM
6:2	106-9989	1	Decal-Warning
6:3	106-7492	1	Decal-Danger
6:4	107-9866	1	Decal-Console, Top
6:5	98-5954	2	Decal-Cover, Missing
7	107-1865	2	R-Clamp
8	104-7050	1	Housing-Manual
9	3296-39	2	Nut-Lock, NI
10	1-633964-03	1	Stop-Brake, Park
11	323-20	2	Screw-HH
12	323-6	2	Screw-HH
13	107-7697	1	Floor Pan ASM
13:2	98-4387	1	Decal-Protection, Ear
13:3	107-1864	1	Decal-Location, Manual
13:4	107-7666	1	Decal-Diesel
14	3258-166	2	Screw-PRH
15	106-7488-03	1	Hinge-Floorpan, LH
16	3296-59	2	Nut-Lock, NI
17	104-7048	1	Cap-Housing
18	321-4	2	Screw-HH
19	106-7489-03	1	Hinge-Floorpan, RH

Ref	Part No.	Qty.	Description
20	106-7498	1	Pocket

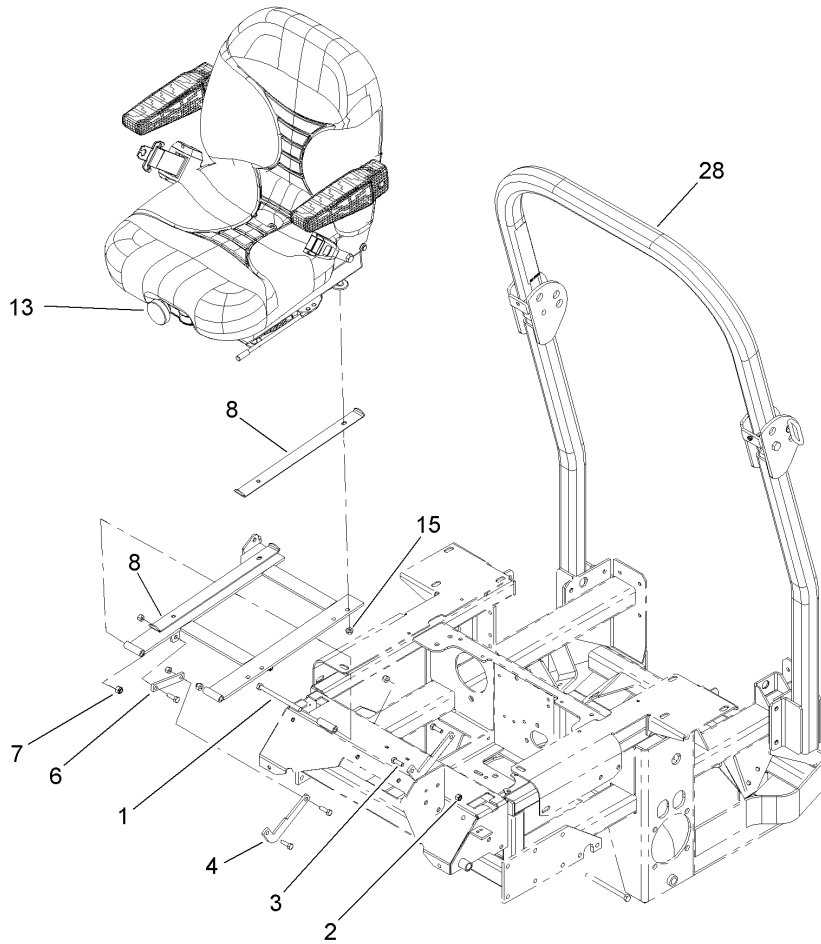

## Seat and Roll-Over Protection System Assembly

Ref	Part No.	Qty.	Description
1	323-39	2	Screw-HH
2	3296-29	4	Nut-Lock, NI
3	322-5	5	Screw-HH
4	109-2759	2	Link-Stop, Seat
6	103-5161	2	Link-Stop, Seat
7	3296-39	2	Nut-Lock, NI
8	1-633872-03	2	Stop-Seat
13	110-0838	1	Deluxe Seat ASM
15	32128-20	4	Nut-HF
28	106-7437	1	ROPS ASM

--	--	--	--

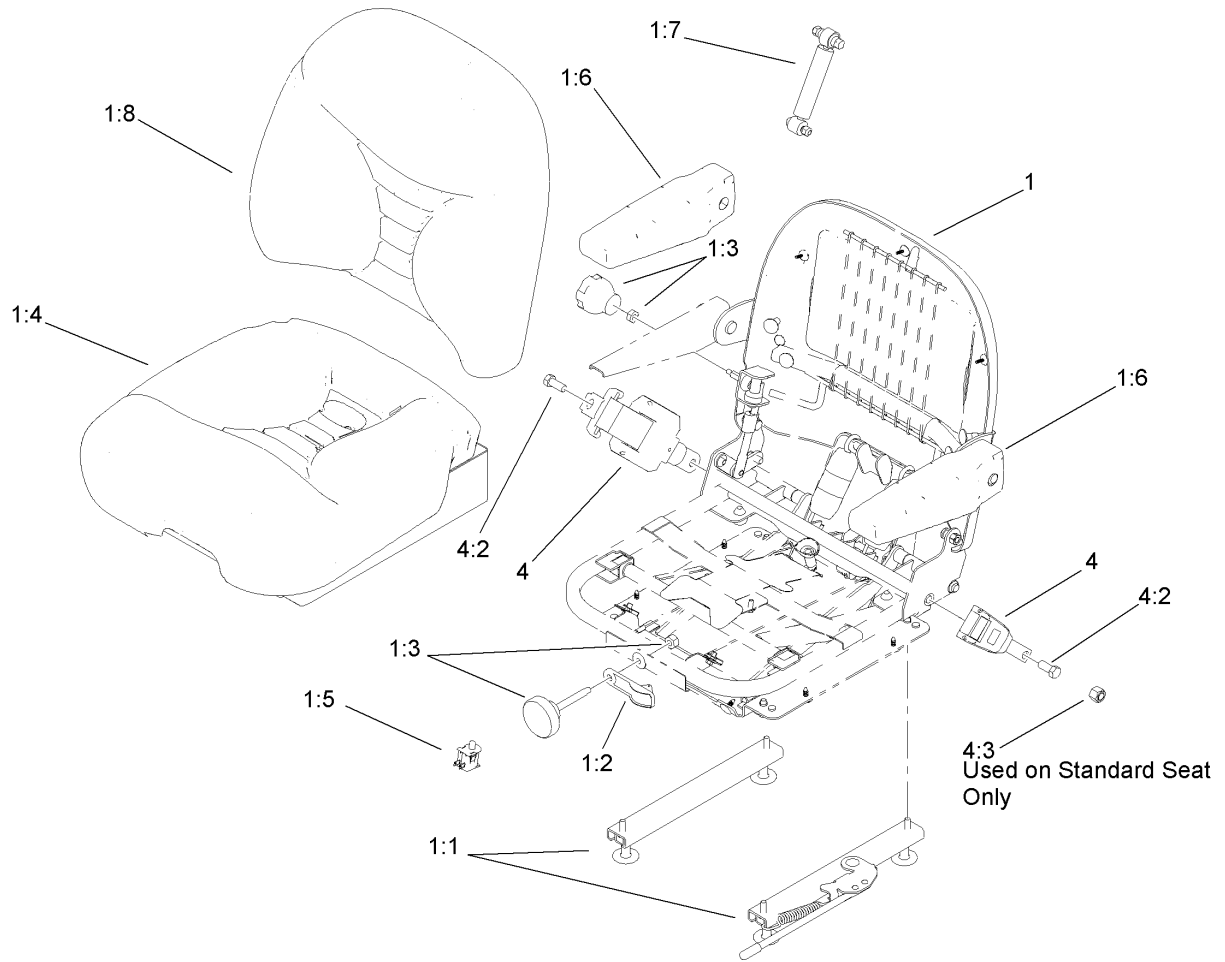

## Deluxe Seat Assembly No. 110-0838

Ref	Part No.	Qty.	Description
①		1	Seat ASM
1:1	107-1880	1	Seat Track Kit
1:2	107-1885	1	Weight Indicator Kit
1:3	107-1881	1	Knob Kit
1:4	107-1883	1	Bottom Cushion Kit
1:5	107-1886	1	Switch Kit
1:6	107-1887	1	Armrest Kit
1:7	107-1884	1	Shock Absorber Kit
1:8	107-1882	1	Back Cushion Kit
4	110-0883	1	Retractable Seatbelt Kit
4:2	3212-4	2	Screw-HH
4:3	3296-7	2	Nut-Lock

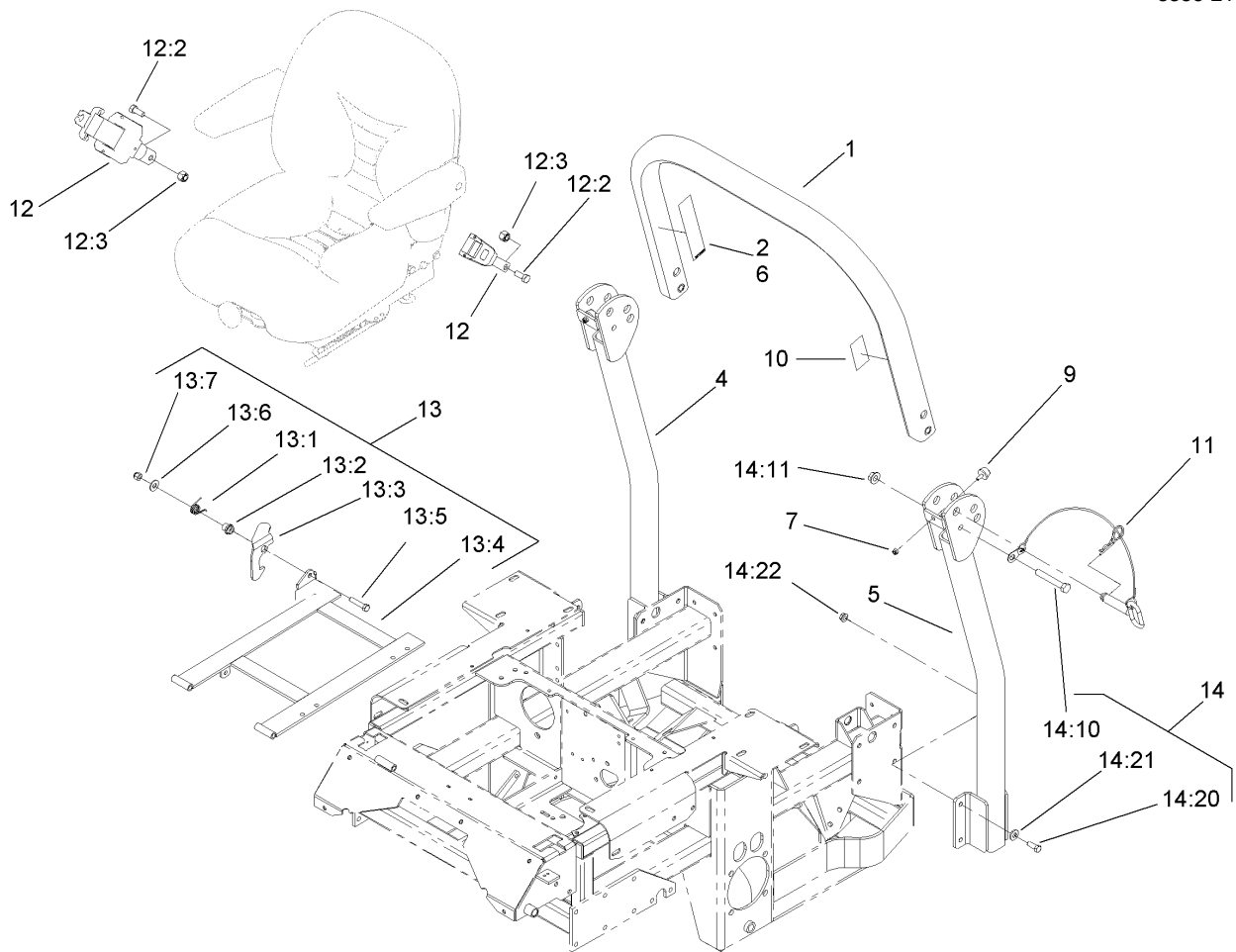

## Roll-Over Protection System Assembly No. 106-7437

Ref	Part No.	Qty.	Description
②1		1	Upper Tube ASM
2	107-2102	1	Decal-Warning, Folding ROPS
②4		1	Tube-Support, RH
②5		1	Tube-Support, LH
6	107-3069	1	Decal-Warning, Folding ROPS (Ce)
7	3296-73	2	Nut-Lock, NI
9	109-2365	2	Bumper-Rubber (W/Stud)
10	107-2101	1	Decal-ROPS
11	103-4553	2	ROPS Fold Pin ASM
12	110-0883	1	Retractable Seatbelt Kit
12:2	3212-4	2	Screw-HH
12:3	3296-7	2	Nut-Lock
13	109-1813	1	Seat Frame Single Latch ASM
13:1	103-5520	1	Catch-Latch, Single
13:2	103-5519	1	Spring-Torsion, Latch
13:3	107-0075	1	Bushing-Latch, Seat
13:4	109-1810-03	1	Frame-Seat, Single Latch
13:5	3256-4	1	Washer-Flat
13:6	3296-39	1	Nut-Lock, NI
13:7	323-9	1	Screw-HH
②14		1	Bag-Bolt
14:10	325-13	2	Screw-HH
14:11	32128-23	2	Nut-HF

Ref	Part No.	Qty.	Description
14:20	323-8	8	Screw-HH
14:21	98-5975	8	Washer-Belleville
14:22	3290-357	8	Nut-HHF, Whiz

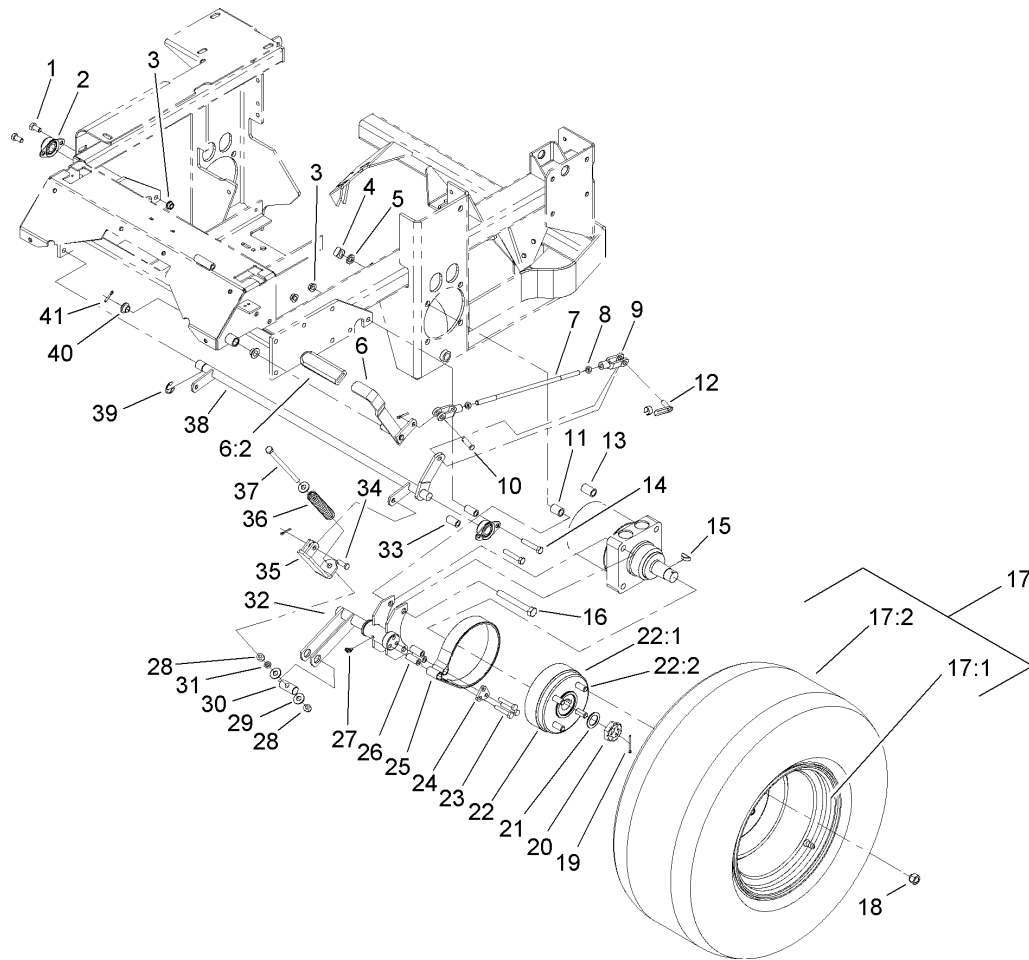

## Wheel and Brake Assembly

Ref	Part No.	Qty.	Description
1	323-4	2	Screw-HH
2	1-633102	2	Bearing-Flange, Side
3	3290-357	4	Nut-HHF, Whiz
4	103-0131	8	Nut-Square
5	3253-7	8	Washer-Lock
6	103-0197	1	Brake Lever And Grip ASM
6:2	1-633268	1	Grip-Lever, Brake
7	103-1708	1	Rod-Brake
8	3219-3	2	Nut-Hex
9	1-633131	2	Yoke-Linkage, Brake
10	1-808285	1	Pin-Clevis
11	109-5037	4	Spacer,Wheel Short
12	103-2399	1	Pin-Spring, Clevis
13	109-5038	4	Spacer,Wheel Long
14	323-10	2	Screw-HH
15	3257-42	2	Key-Woodruff
16	325-20	8	Screw-HH
17	109-3157	2	Wheel And Tire ASM
17:1	109-3156	1	Wheel
17:2	103-4963	1	Tire
18	242-50	8	Nut-Lug
19	1-806800	2	Pin-Cotter
20	1-809036	2	Nut-HH
21	1-523157	2	Washer-Spacer, 14 GA

Ref	Part No.	Qty.	Description
22	103-0590	2	Hub And Wheel ASM
22:1	103-0589	1	Wheel Hub ASM
22:2	1-633926	4	Stud-Wheel
23	322-9	6	Screw-HH
24	103-0374	2	Retainer-Band, Brake
25	103-0355	2	Band-Brake
26	103-0384	6	Spacer
27	302-19	2	Fitting-Grease
28	3296-39	4	Nut-Lock, NI
29	3256-4	6	Washer-Flat
30	1-633144	2	Pin-Trunion
31	3218-3	2	Nut-Jam
32	103-0810-03	2	Brake-Wide
33	103-0051	2	Spacer-Retainer, Brake
34	1-808284	2	Pin-Clevis
35	103-1117-03	2	Linkage-Brake, Lower
36	1-633454	2	Spring-Brake
37	323-58	2	Bolt-TAP, HH
38	103-5243-03	1	Shaft-Brake
39	32151-48	1	E-Ring
40	1-513140	2	Bearing-Control
41	3272-10	4	Pin-Cotter

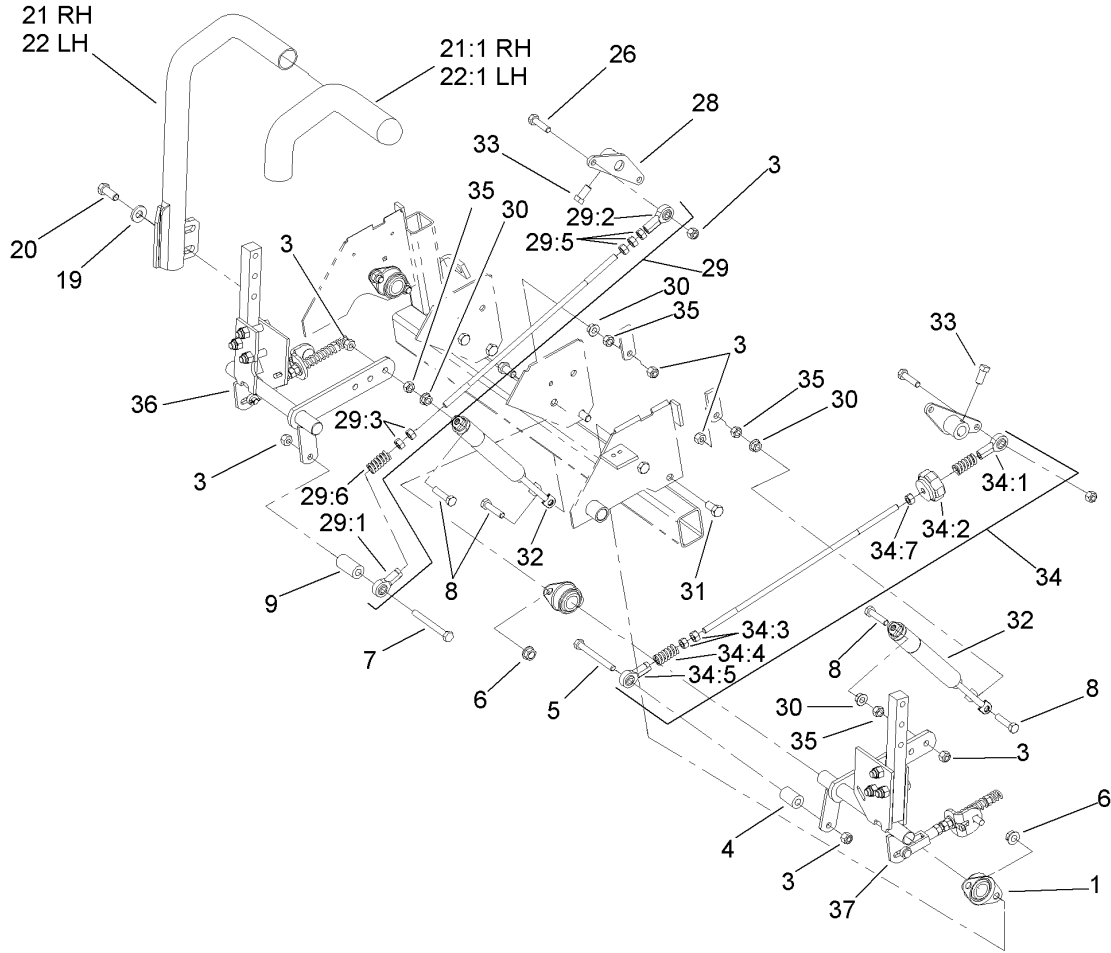

## Motion Control Assembly

Ref	Part No.	Qty.	Description
1	1-633102	4	Bearing-Flange, Side
3	3296-29	8	Nut-Lock, NI
4	103-1361	1	Spacer-Hydro Control, LH
5	322-12	1	Screw-HH
6	3290-357	8	Nut-HHF, Whiz
7	322-14	1	Screw-HH
8	1-403180	4	Screw-HH
9	103-5192	1	Spacer-Control, HYD
19	98-5975	4	Washer-Belleville
20	323-6	4	Screw-HH
21	108-7237	1	RH Lever ASM
21:1	106-9987	1	Grip-Control, Motion
22	108-7238	1	LH Lever ASM
22:1	106-9987	1	Grip-Control, Motion
26	322-6	4	Screw-HH
28	103-0194-03	2	Arm-Control, Hydro
29	103-5190	1	RH HYD Connect Link ASM
29:1	1-543017	1	Balljoint-RH
29:2	1-633152	1	Balljoint-Thread, LH
29:3	1-804524	2	Nut
29:5	3219-2	3	Nut-Hex
29:6	1-323245	1	Spring-Compression
30	32128-20	6	Nut-HF
31	323-4	8	Screw-HH

Ref	Part No.	Qty.	Description
32	109-2339	2	Damper-Control, Motion
33	1-803022	2	Screw-Set
34	103-3062	1	Tracking Rod ASM
34:1	1-543017	1	Balljoint-RH
34:2	103-3060	1	Knob-Tracking
34:3	1-804524	2	Nut
34:4	1-323245	2	Spring-Compression
34:5	1-633152	1	Balljoint-Thread, LH
34:7	3219-2	1	Nut-Hex
35	3217-6	4	Nut-Hex
36	109-3978	1	RH Motion Control ASM
37	109-3979	1	LH Motion Control ASM



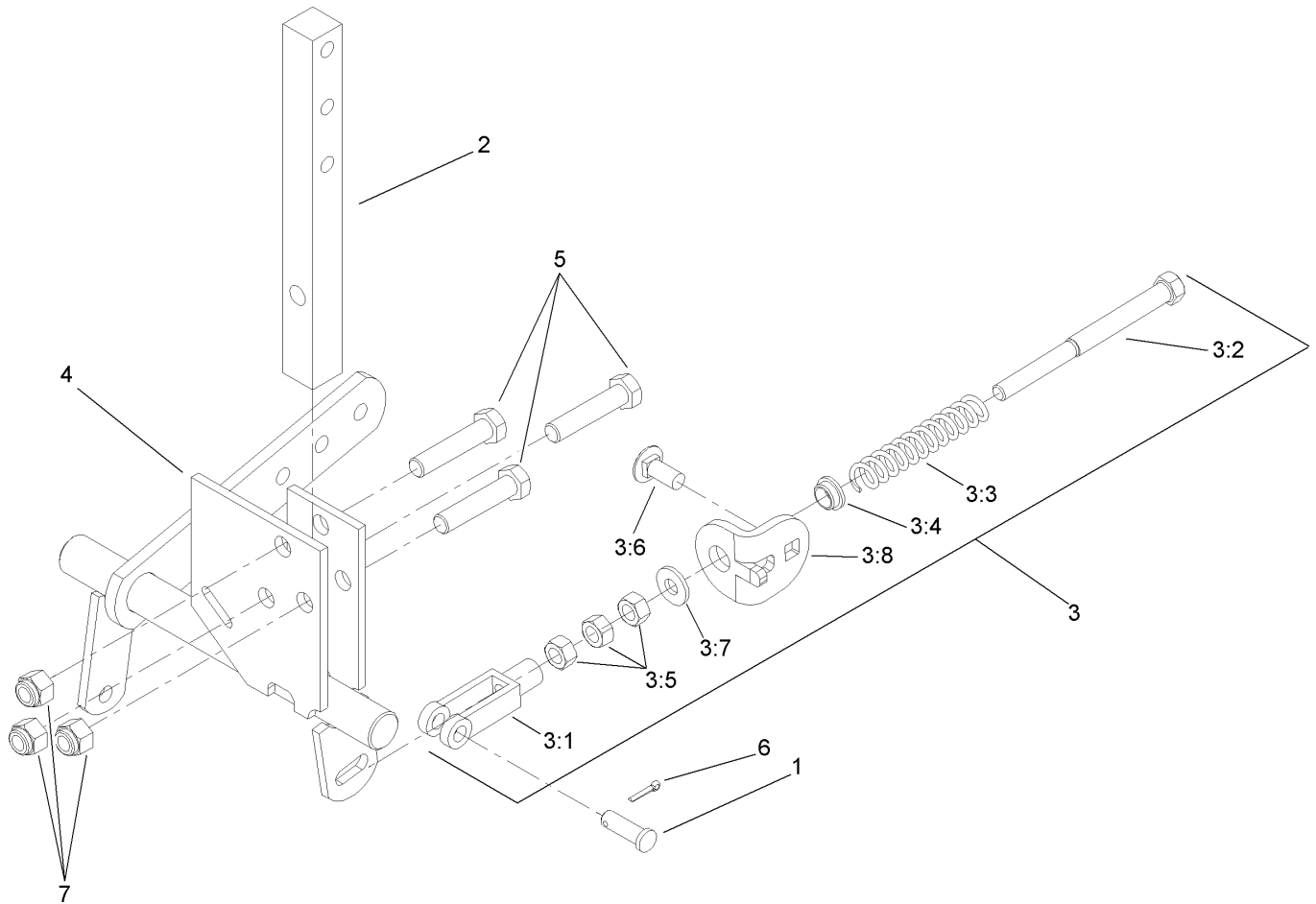

## LH Motion Control Assembly No. 109-3979

Ref	Part No.	Qty.	Description
1	1-808280	1	Pin-Clevis
2	103-0407	1	Arm-Shaft, Control
3	109-3903	1	Neutral Return ASM
3:1	1-303105	1	Yoke-Adjustable
3:2	1-603737	1	Bolt-Return, Neutral
3:3	1-603807	1	Spring-Return, Neutral
3:4	109-3769	1	Bushing, Nylon Flanged
3:5	3219-2	3	Nut-Hex
3:6	3230-23	1	Screw-CARR
3:7	3256-2	1	Washer-Flat
3:8	109-3908	1	Tab, Adjustment
4	109-3983	1	Control-Motion, LH
5	323-9	3	Screw-HH
6	3272-5	1	Pin-Cotter
7	3296-39	3	Nut-Lock, NI

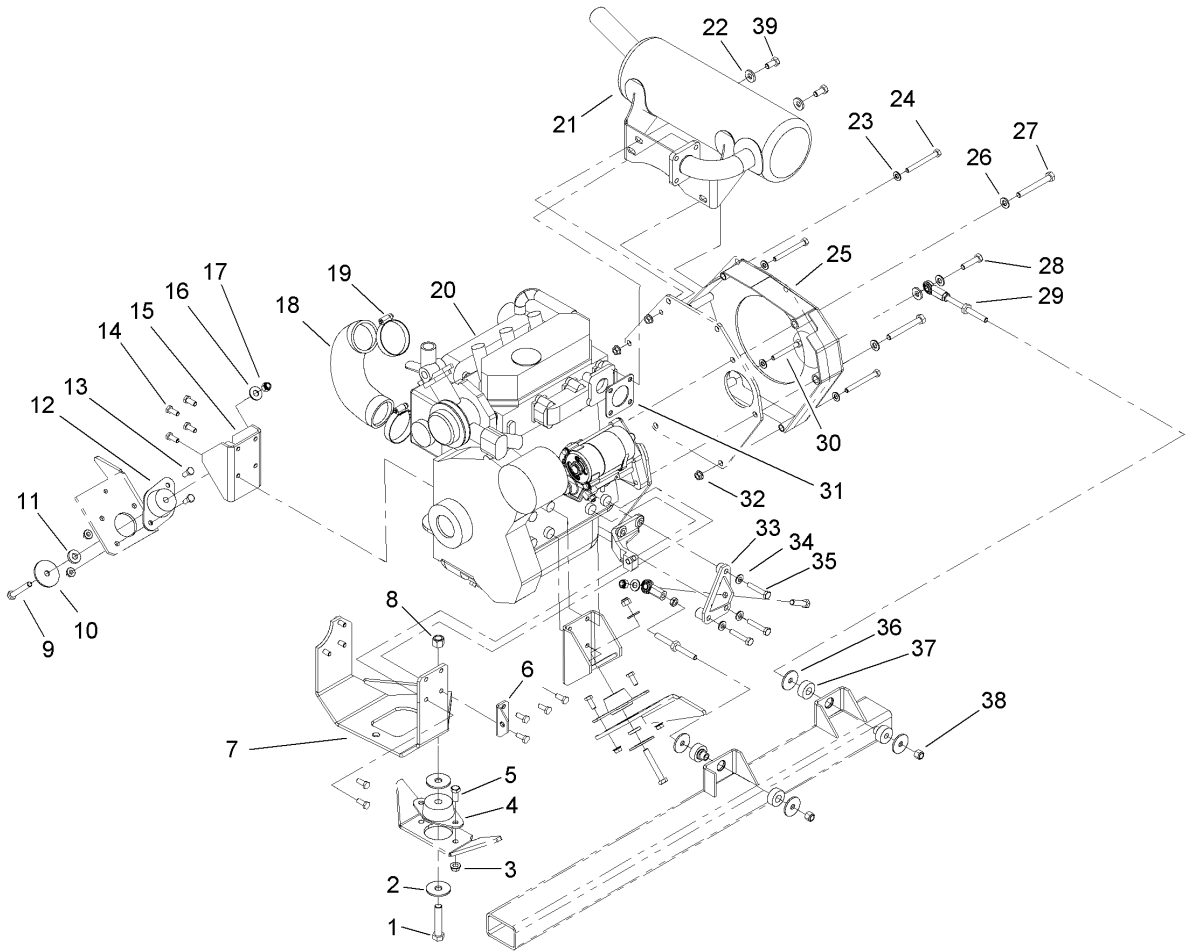

## Engine Mount Assembly

Ref	Part No.	Qty.	Description
1	325-10	1	Screw-HH
2	86-1990	2	Washer
3	3290-357	2	Nut-HHF, Whiz
4	103-1022	1	Isolator-Rear
5	323-5	2	Screw-HH
6	103-3908	1	Bracket-Ground
7	103-0870-03	1	Rear Engine Mount ASM
8	3296-23	1	Nut-Lock, NI
9	323-12	2	Screw-HH
10	83-1040	2	Washer-Flat
11	66-6480	2	Washer
12	103-2613	2	Isolator-Side
13	322-3	4	Screw-HH
14	33114-020	15	Screw-HH
15	103-0839-03	2	LH And RH Engine Mount ASM
16	3256-4	2	Washer-Flat
17	3296-39	3	Nut-Lock, NI
18	103-0921	1	Hose
19	2412-42	2	Clamp-Hose
20	103-0888	1	Engine-Daihatsu
21	103-2592	1	Muffler Kit
22	98-5975	3	Washer-Belleville
23	3256-23	4	Washer-Flat
24	322-14	3	Screw-HH

Ref	Part No.	Qty.	Description
25	103-3573-03	1	Cover-Flywheel
26	3256-24	4	Washer-Flat
27	56-2150	2	Screw-HH
28	323-8	2	Screw-HH
29	103-3745	2	Ball Joint Link ASM
30	322-12	1	Screw-HH
31	103-1385	1	Gasket-Muffler
32	32128-20	7	Nut-HF
33	103-3556-03	1	Bracket-Engine, Front
34	1-303334	3	Washer-Spring
35	33114-045	3	Screw-HH
36	93-6099	4	Washer
37	103-3568	2	Isolator-Link
38	3296-6	2	Nut-Lock
39	63-7790	3	Screw-Cap

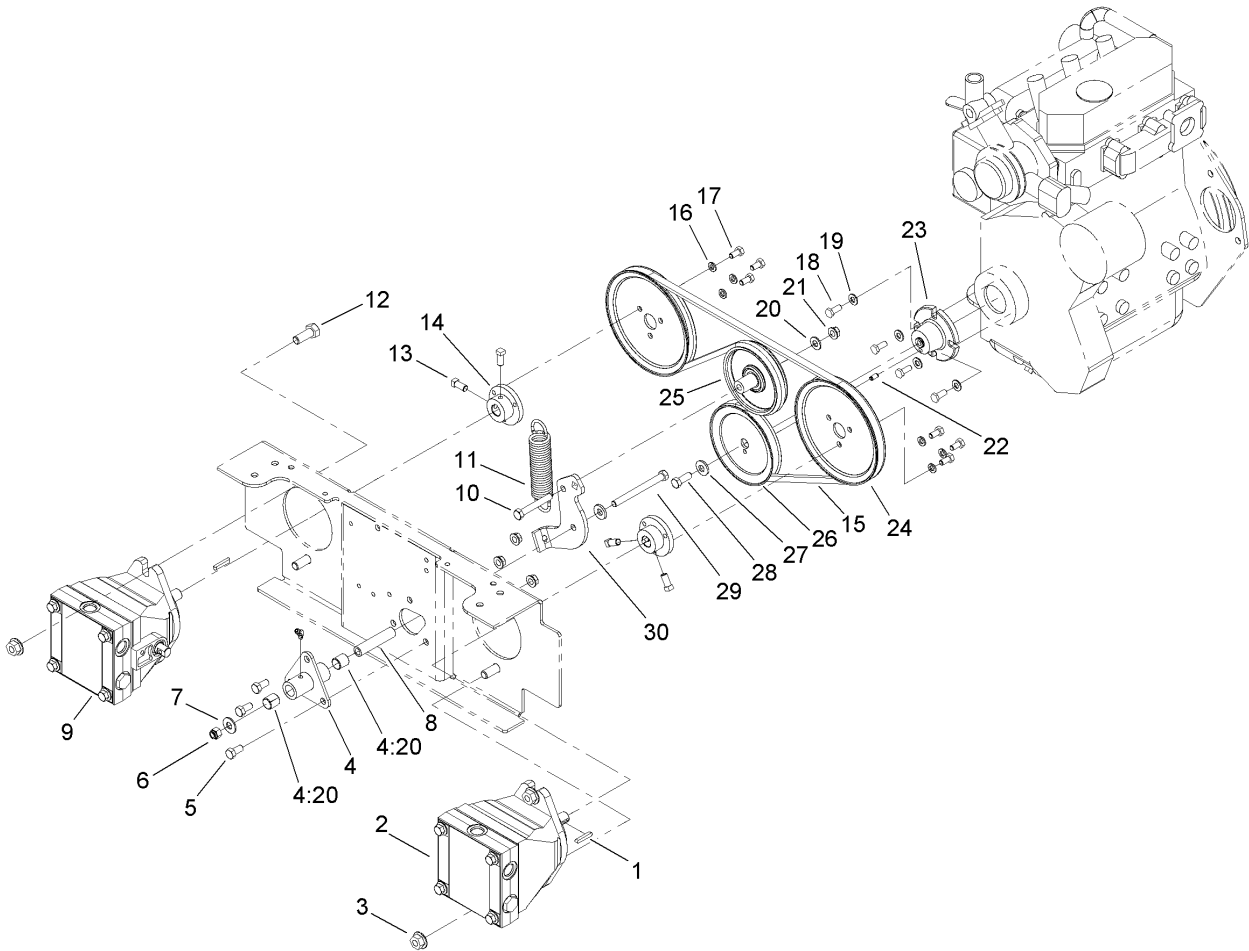

## Wheel Pump Drive Assembly

Ref	Part No.	Qty.	Description
1	103-2739	2	Key
2	103-2978	1	Pump-Hydro, LH
●2:1	100-6110	1	Overhaul Seal Kit
3	32128-49	4	Nut-HHF
4	103-4467	1	Pump Idler ASM
4:20	1-513034	2	Sleeve-Bearing
5	323-4	3	Screw-HH
6	3296-39	1	Nut-Lock, NI
7	3256-4	1	Washer-Flat
8	103-0919	1	Bushing-Tightener, Pivot
9	103-2979	1	Pump-Hydro, RH
●9:1	100-6110	1	Overhaul Seal Kit
10	323-12	1	Screw-HH
11	103-1767	1	Spring-Extension
12	325-5	4	Screw-HH
13	1-803050	4	Screw-Set
14	103-1471	2	Hub-Pump
15	107-7724	1	Belt-V
16	1-805005	6	Washer-Lock
17	322-2	6	Screw-HH
18	33114-020	4	Screw-HH
19	3256-23	4	Washer-Flat
20	3256-24	1	Washer-Flat
21	3290-357	4	Nut-HHF, Whiz

Ref	Part No.	Qty.	Description
22	103-1459	1	Pin-Roll
23	103-1421	1	Hub-Drive, Pump
24	103-1472	2	Sheave-Pump
25	103-4464	1	Idler-Pump
26	103-5164	1	Sheave-Engine
27	98-5975	2	Washer-Belleville
28	323-6	1	Screw-HH
29	323-16	1	Screw-HH
30	103-4463-03	1	Arm-Tightener, Pump

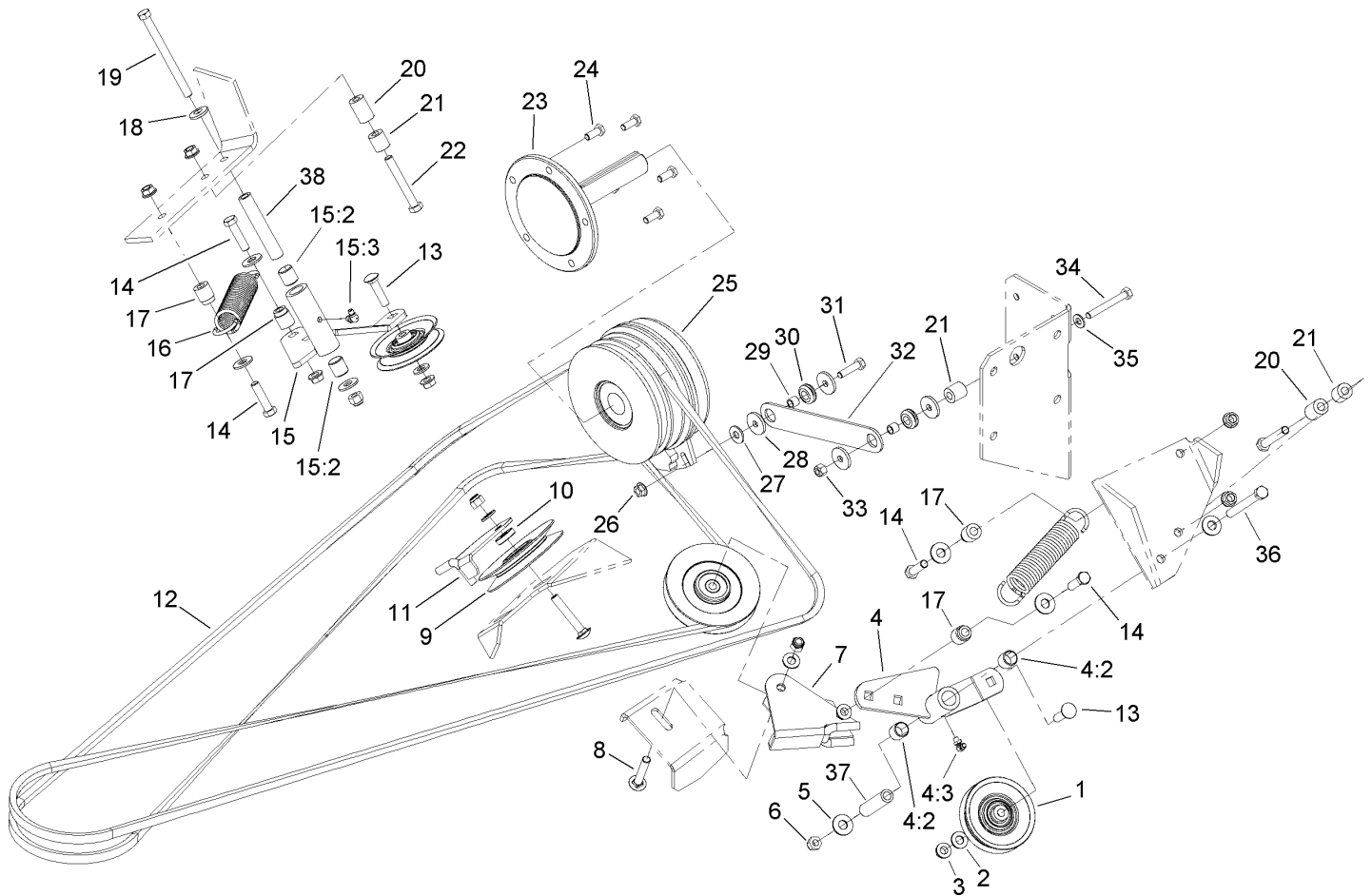

## Deck Belt Drive Assembly

Ref	Part No.	Qty.	Description
1	103-0983	2	Sheave
2	3256-24	4	Washer-Flat
3	3290-357	7	Nut-HHF, Whiz
4	107-9851	1	LH Idler ASM
4:2	1-513034	2	Sleeve-Bearing
4:3	302-40	1	Fitting-Grease
5	3256-4	6	Washer-Flat
6	3296-39	4	Nut-Lock, NI
7	103-4011-03	1	Guard-Belt Sheave, LH
8	3231-40	2	Bolt-CARR
9	103-0984	2	Sheave
10	103-3186	1	Spacer-Bracket, Guide
11	103-4039-03	1	Guard-Belt Sheave, RH
12	107-7738	2	Belt-V
13	3231-4	2	Screw-CARR
14	323-9	4	Screw-HH
15	107-9861	1	RH Idler ASM
15:2	1-513034	2	Sleeve-Bearing
15:3	302-40	1	Fitting-Grease
16	103-1767	2	Spring-Extension
17	103-1503	4	Spacer-Tightener, Belt
18	98-5975	2	Washer-Belleville
19	323-23	1	Screw-HH
20	103-1361	2	Spacer-Hydro Control, LH

Ref	Part No.	Qty.	Description
21	103-0193	3	Spacer-Strap, Clutch
22	323-13	2	Screw-HH
23	103-0286	1	Shaft-Stub
24	33114-020	5	Screw-HH
25	103-0083	1	Clutch ASM
26	32128-20	1	Nut-HF
27	3256-3	1	Washer-Flat
28	1-613235	4	Washer
29	1-633545	2	Spacer
30	1-633630	2	Grommet-Brake
31	322-6	1	Screw-HH
32	103-0192-03	1	Strap-Clutch / Brake
33	3296-29	1	Nut-Lock, NI
34	322-12	1	Screw-HH
35	3256-23	1	Washer-Flat
36	323-16	1	Screw-HH
37	103-0919	1	Bushing-Tightener, Pivot
38	103-0040	1	Bushing-Tightener, Pivot

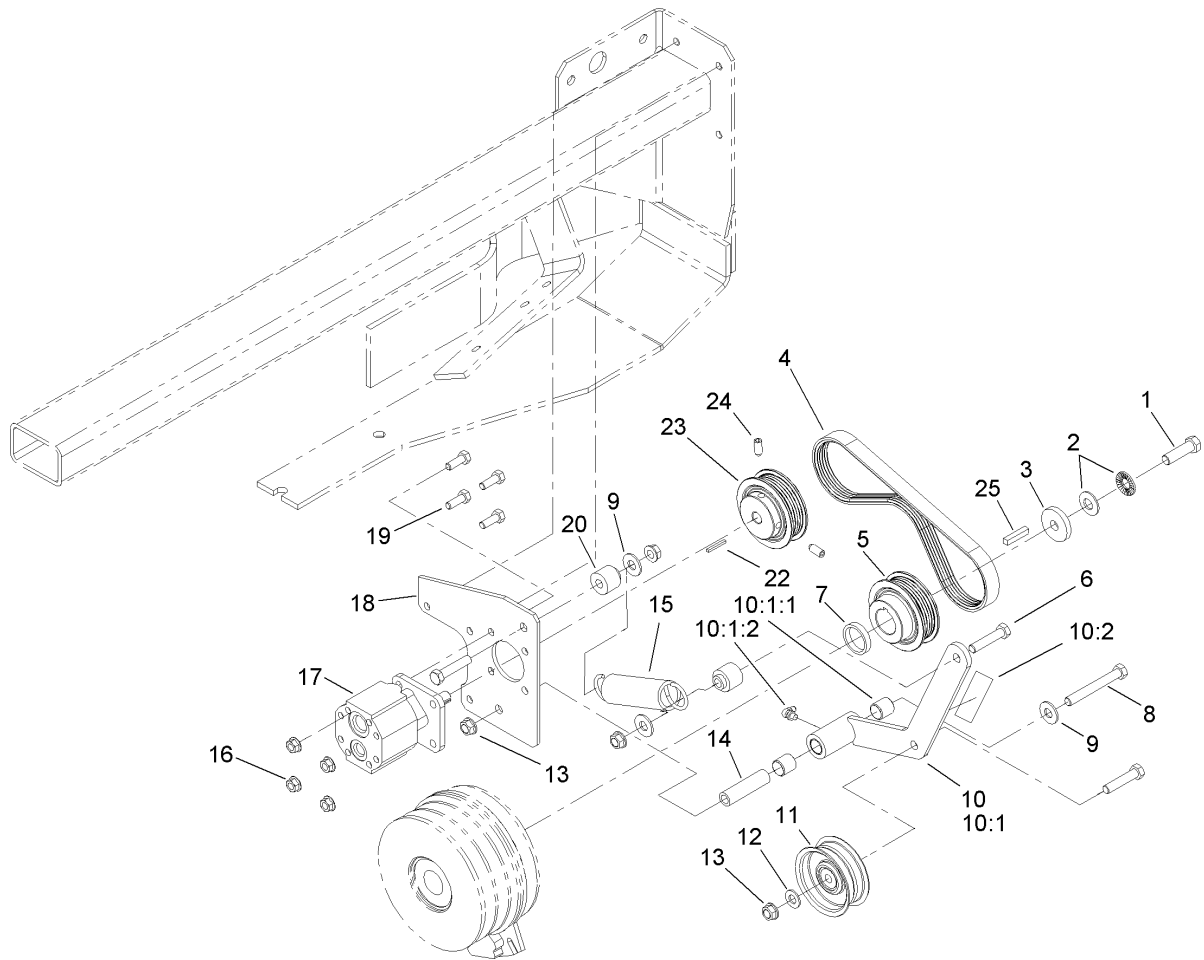

## Cooling Pump Drive Assembly

Ref	Part No.	Qty.	Description
1	3212-6	1	Screw-HH
2	1-603610	2	Washer-Spring
3	1-543610	1	Washer-Clutch
4	107-7739	1	Belt-Poly V
5	103-1339	1	Sheave-5 Rib
6	323-9	3	Screw-HH
7	103-1422	1	Spacer-Pump Drive, Fan
8	323-14	1	Screw-HH
9	3256-4	3	Washer-Flat
10	107-9879	1	Wheel Pump Tension ASM
10:1		1	Tensioner ASM
10:1:1	1-513034	2	Sleeve-Bearing
10:1:2	302-40	1	Fitting-Grease
10:2	98-5954	1	Decal-Cover, Missing
11	1-633167	1	Sheave-Idler
12	3256-24	1	Washer-Flat
13	3290-357	4	Nut-HHF, Whiz
14	1-603384	1	Bushing-Pivot, Idler
15	1-603414	1	Spring-Extension
16	3296-29	4	Nut-Lock, NI
17	103-7431	1	Pump-Fan, Cooling
18	103-1299-03	1	Plate-Mating, Fan Pump
19	322-4	4	Screw-HH
20	103-1575	2	Spacer-Spring, Fan Pump

Ref	Part No.	Qty.	Description
22	32150-1	1	Key-Square
23	103-1338	1	Sheave-5 Rib
24	3246-6	2	Screw-Set, HSH
25	13-2840	1	Key-Square

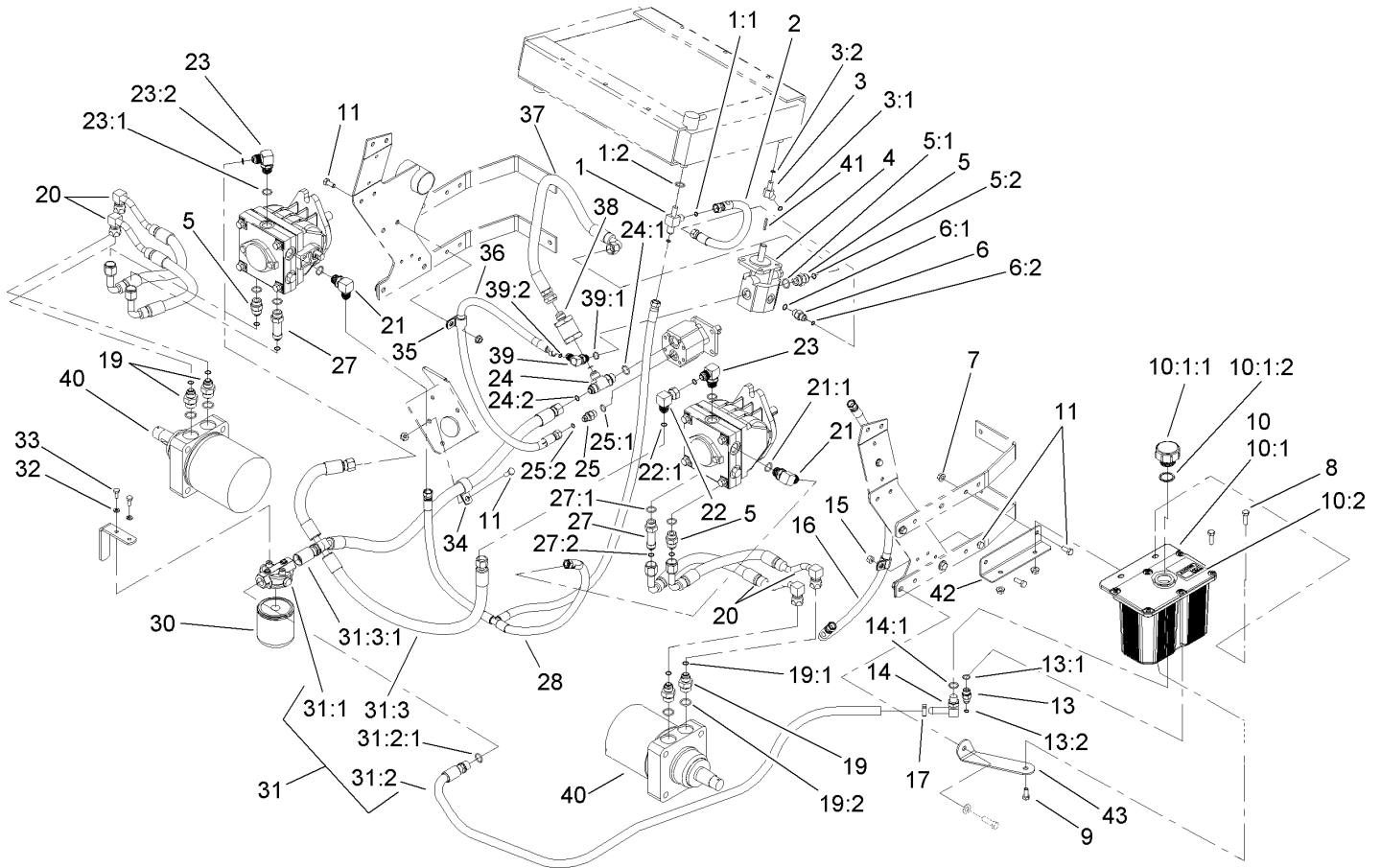

## Hydraulic System Assembly

Ref	Part No.	Qty.	Description
1	108-5998	1	Fitting-HYD, Straight Tee
1:1	237-21	2	O-Ring
1:2	237-42	1	O-Ring
2	103-2173	1	Fan Case Drain Hose ASM
3	108-5999	1	Fitting-HYD, 45 Elbow
3:1	237-21	1	O-Ring
3:2	237-42	1	O-Ring
4	103-7430	1	Motor-Fan, Cooling
5	1-603990	3	Fitting-Straight
5:1	1-603920	1	O-Ring
5:2	1-603992	1	O-Ring
6	103-2157	1	Fitting-Straight
6:1	1-603923	1	O-Ring
6:2	103-1020	1	O-Ring
7	32128-20	7	Nut-HF
8	322-5	4	Screw-HH
9	322-3	2	Screw-HH
10	109-0582	1	Hydraulic Tank ASM
10:1		1	Tank-Hydraulic
10:1:1	103-1948	1	Cap-Reservoir, HYD
10:1:2	103-1949	1	Gasket-Cap
10:2	1-523552	1	Decal-Tank, HYD
11	322-4	5	Screw-HH
13	103-2156	1	Fitting-Straight

Ref	Part No.	Qty.	Description
13:1	1-603921	1	O-Ring
13:2	103-1020	1	O-Ring
14	108-5316	1	Fitting-Elbow, 90 DEG
14:1	237-79	1	O-Ring
15	3296-29	1	Nut-Lock, NI
16	103-2174	1	Tank Return Hose ASM
17	103-2104	1	Clamp-Hose
19	1-603991	4	Fitting-Straight
19:1	237-80	1	O-Ring
19:2	1-603992	1	O-Ring
20	103-4679	4	Hose
21	103-1014	2	Fitting-Elbow, 90 DEG
21:1	1-603920	1	O-Ring
22	103-2315	1	Fitting-90 DEG
22:1	1-603992	1	O-Ring
23	103-2153	2	Fitting-90 DEG
23:1	1-603920	1	O-Ring
23:2	1-603992	1	O-Ring
24	103-2159	1	Fitting-Tee
24:1	1-603920	1	O-Ring
24:2	1-603992	2	O-Ring
25	103-2156	1	Fitting-Straight
25:1	1-603921	1	O-Ring
25:2	103-1020	1	O-Ring

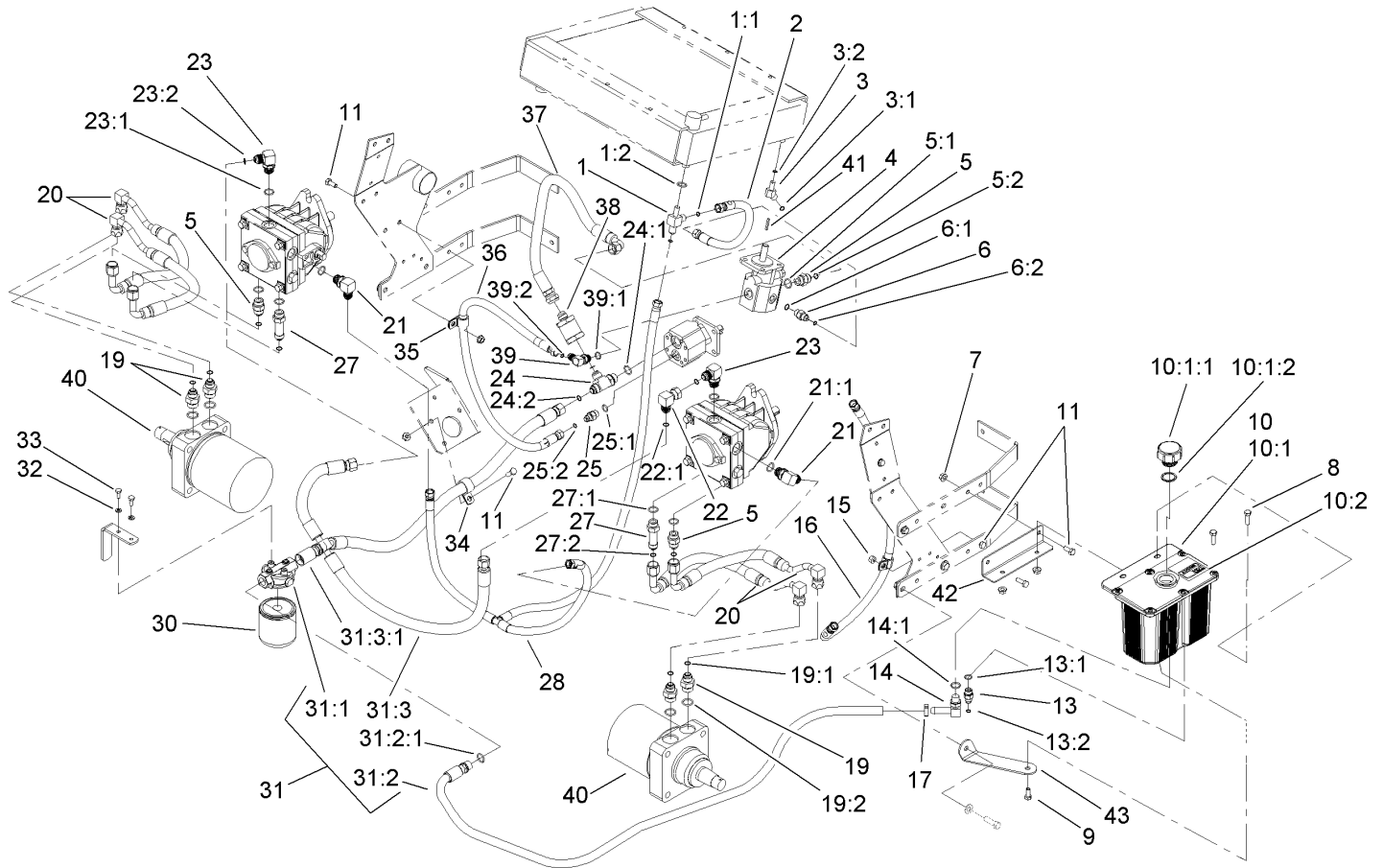

## Hydraulic System Assembly (continued)

Ref	Part No.	Qty.	Description
27	103-1940	2	Adapter-HYD, Straight
27:1	237-79	1	O-Ring
27:2	1-603992	1	O-Ring
28	103-2172	1	Case Drain Hose ASM
30	23-9740	1	Filter-Oil
31	103-5120	1	Charge Hose ASM
31:1	103-2259	1	Head-Filter
31:2	103-5121	1	Filter Inlet Hose ASM
31:2:1	1-603920	1	O-Ring
31:3	103-2269	1	Pump Inlet Hose ASM
31:3:1	1-603920	1	O-Ring
32	1-805004	2	Washer-Lock
33	321-3	2	Screw-HH
34	1-643312	1	Clip-Loom
35	1-633396	2	Clip-Loom
36	103-2148	1	Auxillary Pump Hose ASM
37	1-323241	1	Hose-Pressure, High
38	103-3110	1	Filter-In Line, 50 Micron
39	103-2155	1	Fitting-90 DEG
39:1	1-603921	1	O-Ring
39:2	103-1020	1	O-Ring
40	103-2489	2	Motor-Wheel, HYD
41	32150-1	1	Key-Square
42	112-1768-03	1	Bracket-Tank Mount,Upper

Ref	Part No.	Qty.	Description
43	112-1778-03	1	Bracket-Tank Mount,Lower

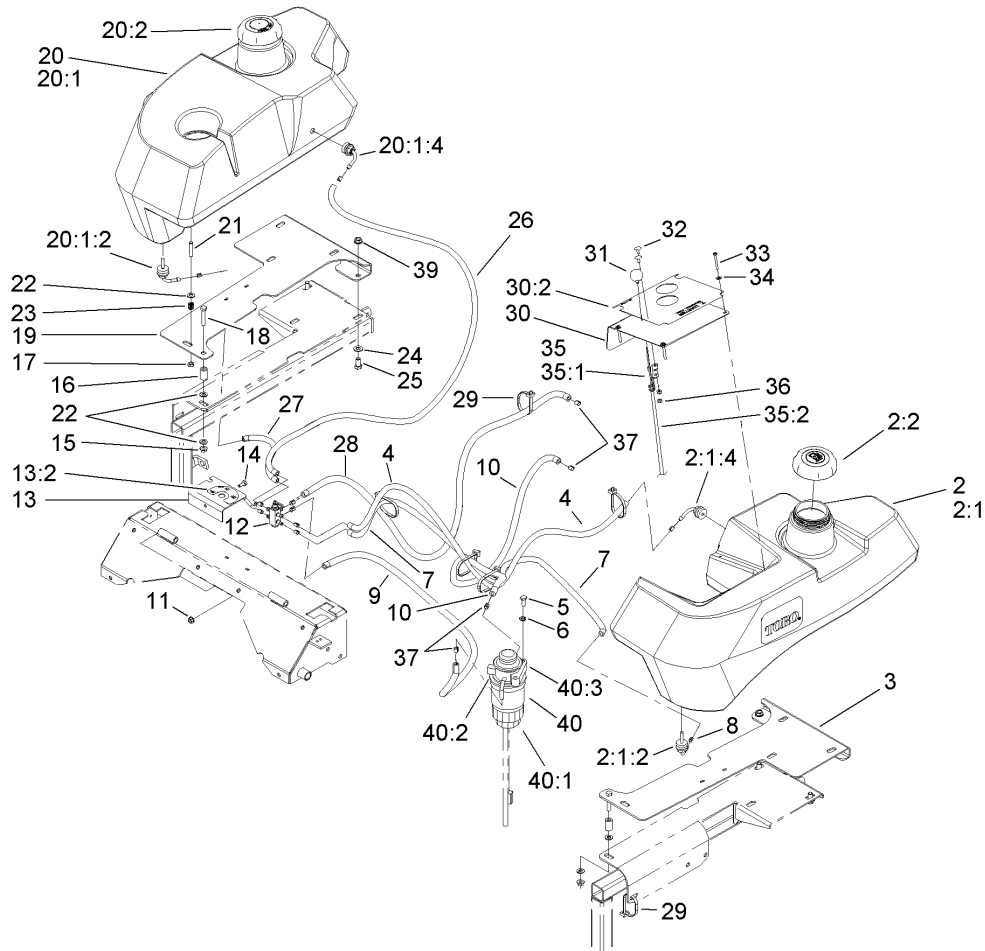

## Tank and Fuel Line Assembly

Ref	Part No.	Qty.	Description
2	110-4167	1	LH Fuel Tank Kit ASM
2:1		1	Tank-Fuel, LH
2:1:2	103-2605	1	Fitting-Fuel, Bulkhead
2:1:4	103-2615	1	Fitting-Fuel, Bulkhead
2:2	109-0347	1	Cap-Fuel, Diesel
3	107-7672-03	1	Bracket-Fuel Tank, LH
4	109-0273	1	Hose-Fuel
5	33114-020	2	Screw-HH
6	1-805005	2	Washer-Lock
7	109-0289	1	Hose-Fuel
8	1-643293	8	Clamp-Hose, Fuel
9	110-4114	1	Hose-Fuel
10	110-4172	1	Hose-Fuel
11	32128-23	1	Nut-HF
12	1-643234	1	Valve-Fuel, Dual Flow
13	107-9878	1	Bracket-Valve, Fuel
13:2	107-2114	1	Decal-Valve, Fuel
14	321-3	1	Screw-HH
15	3296-47	2	Nut-Lock, NI
16	94-7564	2	Spacer
17	3296-47	6	Nut-Lock, NI
18	322-9	2	Screw-HH
19	107-7671-03	1	Bracket-Fuel Tank, RH
20	110-4166	1	RH Fuel Tank Kit ASM

Ref	Part No.	Qty.	Description
20:1		1	Tank-Fuel, RH
20:1:2	103-2605	1	Fitting-Fuel, Bulkhead
20:1:4	103-2615	1	Fitting-Fuel, Bulkhead
20:2	109-0347	1	Cap-Fuel, Diesel
21	1-633023	6	Stud
22	3256-23	10	Washer-Flat
23	1-633349	6	Spring-Tank, Fuel
24	3256-24	4	Washer-Flat
25	323-4	4	Screw-HH
26	110-5701	1	Hose-Fuel
27	109-0294	1	Hose-Fuel
28	110-4100	1	Hose-Fuel
29	1-303335	6	Tie-Plastic
30	110-5734	1	Control Panel ASM
30:2	110-5733	1	Decal-Panel, Control
31	1-603175	1	Knob-Ball
32	1-807513	2	Bolt-CARR
33	1-803071	4	Screw
34	1-303435	4	Washer-Spring
35	110-5729	1	Throttle Control Cable ASM
35:1	112-2334	1	Lever Throttle Cable
35:2	110-5730	1	Cable-Throttle
36	3296-2	2	Nut-Lock
37	1-643277	6	Clamp-Hose, Fuel

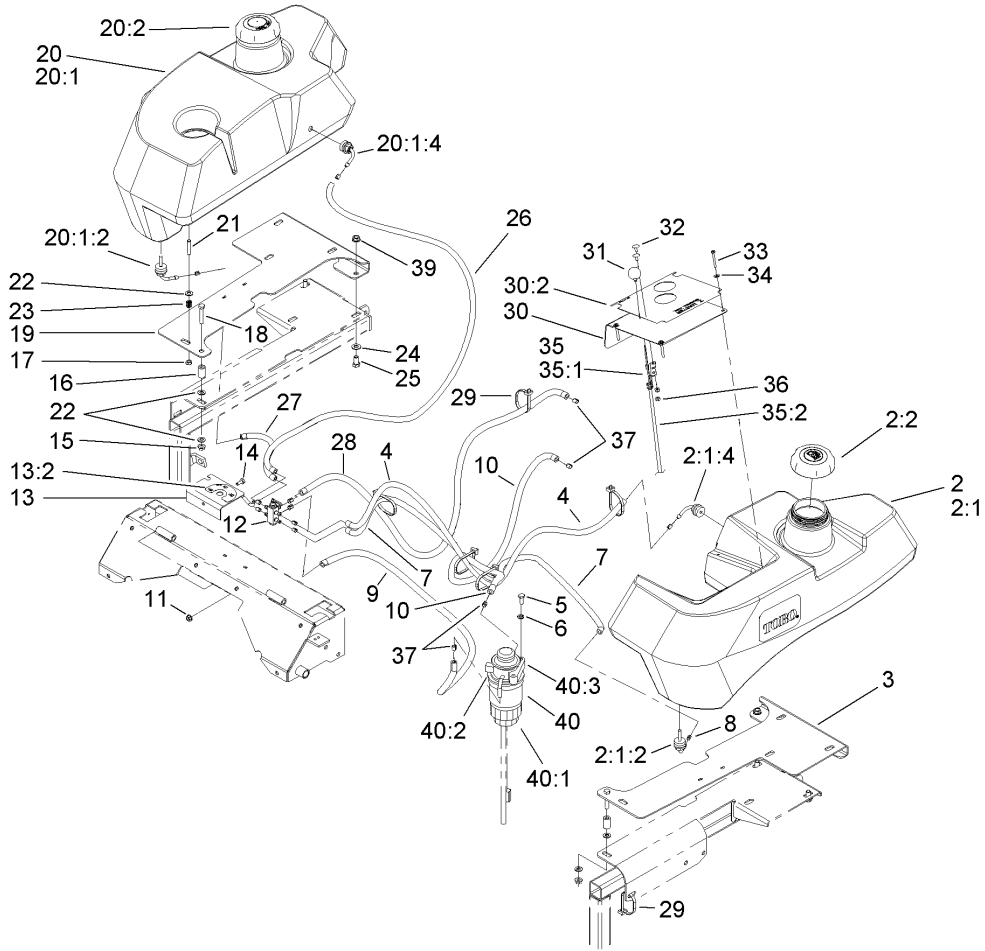

### Tank and Fuel Line Assembly (continued)

Ref	Part No.	Qty.	Description
39	3290-357	4	Nut-HHF, Whiz
40	100-3191	1	Separator-Fuel
40:1	100-3192	1	Element-Filter, Fuel
40:2	100-6409	1	Sensor-Filter, Fuel
40:3	100-6408	1	Cover-Filter

--	--	--	--

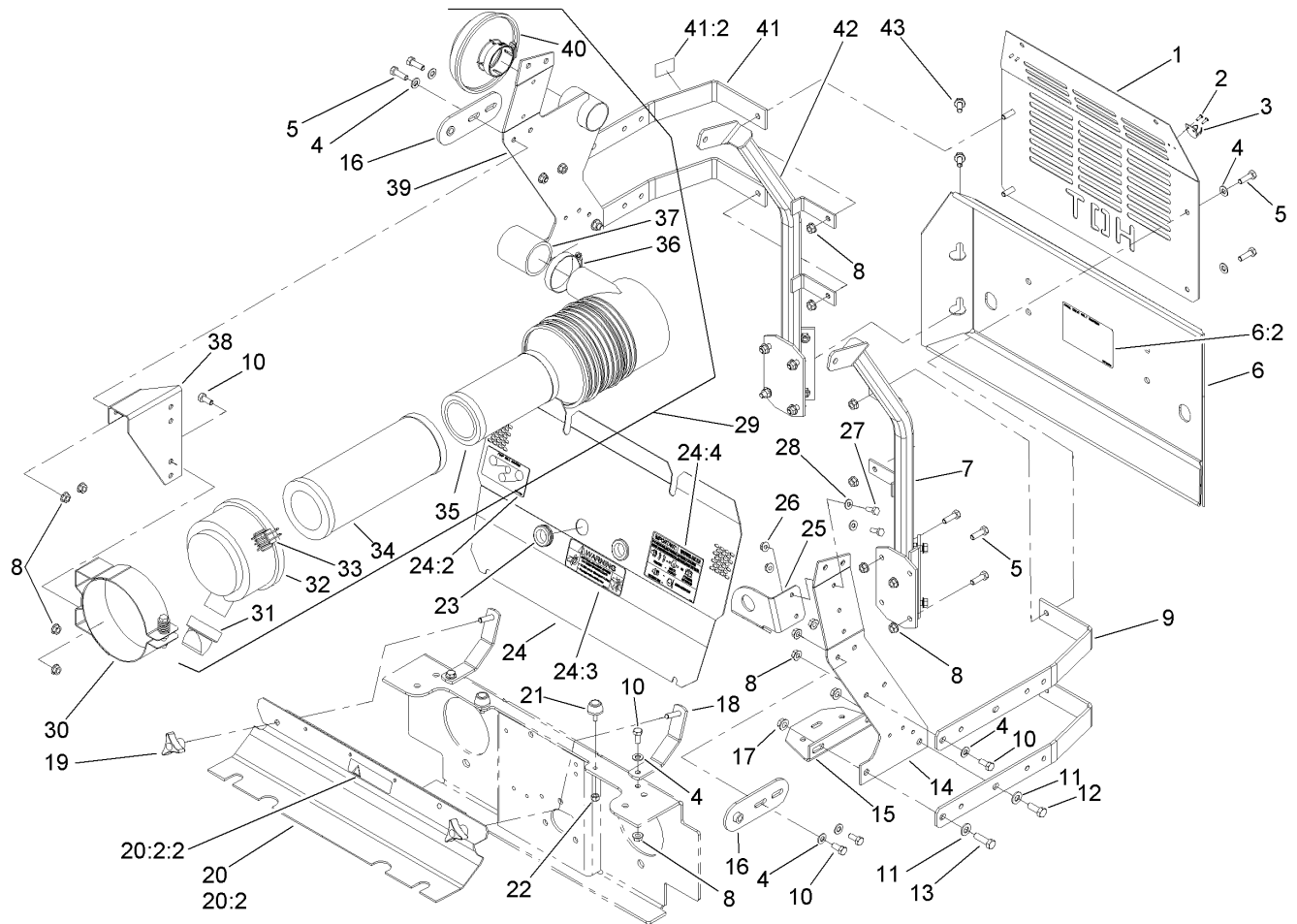

## Front and Rear Engine Cover Assembly

Ref	Part No.	Qty.	Description
1	103-4855-03	1	Guard-Muffler
2	923786	4	Rivet
3	1-643189	2	Keeper-Latch, Rubber
4	3256-23	13	Washer-Flat
5	322-5	14	Screw-HH
6	107-9865	1	Rear Bumper ASM
6:2	107-9864	1	Decal-Belt Routing, Deck Drive
7	103-5157-03	1	Frame-Upper, LH Rear
8	32128-20	23	Nut-HF
9	103-4906-03	3	Bar-Mount Frame, Radiator
10	322-3	9	Screw-HH
11	3256-24	4	Washer-Flat
12	323-6	2	Screw-HH
13	323-7	2	Screw-HH
14	103-5169-03	1	Mount-Side, LH
15	103-2603-03	1	Bracket-Bottle
16	1-632986-03	2	Shackle-Hinge
17	3290-357	4	Nut-HHF, Whiz
18	103-5163-03	2	Mount-Belt Shield, Engine
19	1-323385	2	Knob-3 Prong
20	107-7709	1	Engine Belt Shield ASM
20:2	107-7713	1	Strip-Shield, Belt
20:2:2	98-5954	1	Decal-Cover, Missing
21	109-2365	2	Bumper-Rubber (W/Stud)

Ref	Part No.	Qty.	Description
22	3296-42	2	Nut-Lock, NI
23	100-3815	2	Grommet-Rubber
24	107-7707	1	Engine Access Panel ASM
24:2	107-7705	1	Decal-Belt Routing, Pump
24:3	103-3276	1	Decal-Buzzer, Warning
24:4	103-5881	1	Decal-Devices, Rotating
25	103-4982-03	1	Bracket-Buzzer
26	32128-33	2	Nut-HF
27	321-4	2	Screw-HH
28	3256-22	2	Washer-Flat
29	103-5178	1	Filter-Air
30	103-1058	1	Bracket-Filter, Air
31	87-9400	1	Valve-Vacuator
32	103-1060	1	Cover-Filter, Air
33	1-643283	2	Latch-Cleaner, Air
34	103-1327	1	Filter-Air
35	103-1326	1	Filter-Air, Safety
36	2412-42	1	Clamp-Hose
37	103-5198	1	Hose-Intake
38	103-0953-03	1	Mount-Cleaner, Air
39	103-5123-03	1	RH Radiator And Ac Support ASM
40	100-2436	1	Hood
41	107-7715	1	Bar-Radiator
41:2	65-2690	1	Decal-Surface, Hot



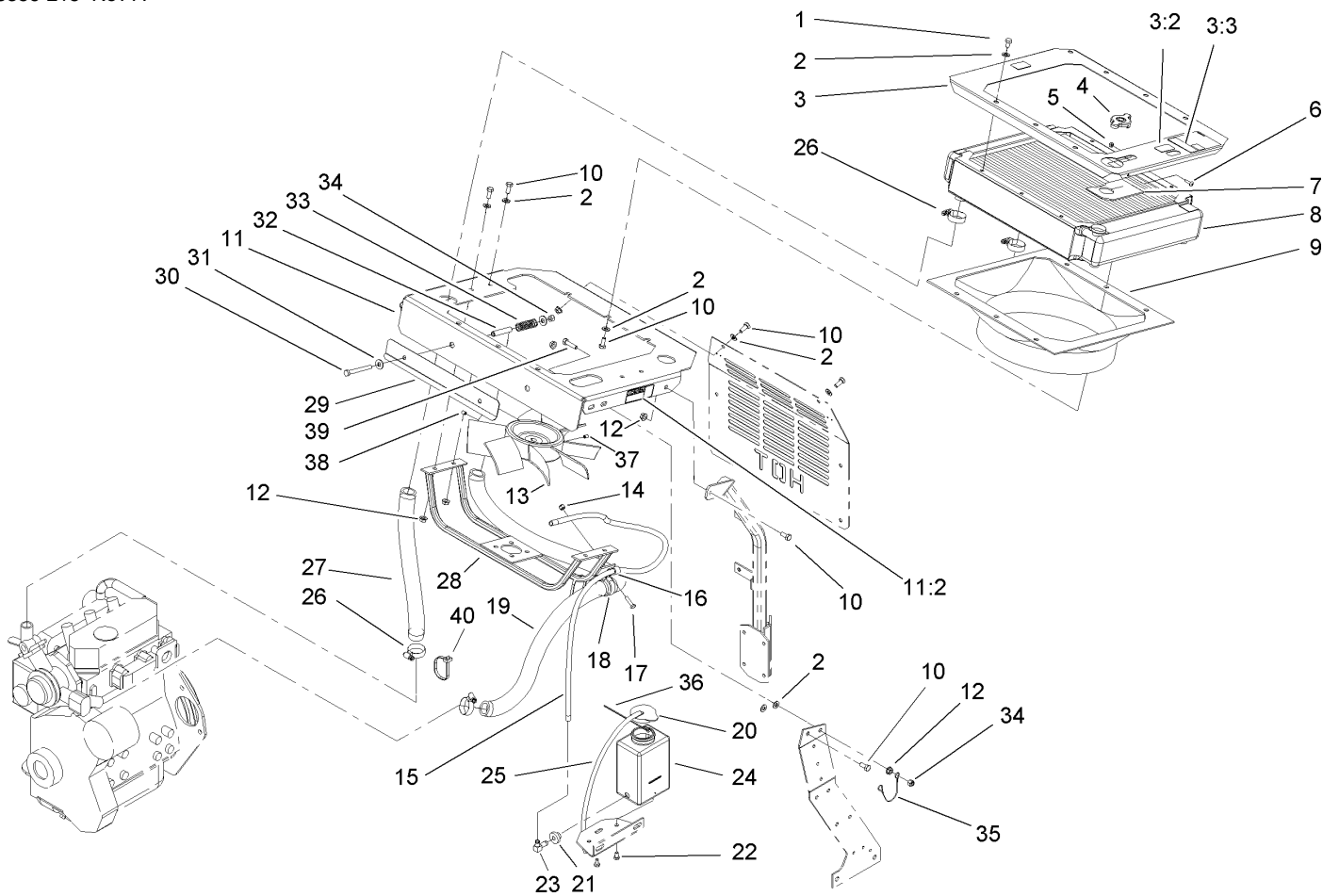

## Cooling System Assembly

Ref	Part No.	Qty.	Description
1	322-1	6	Screw-HH
2	3256-23	22	Washer-Flat
3	107-7658	1	Plate-Trim, Radiator
3:2	65-2690	2	Decal-Surface, Hot
3:3	104-2449	1	Decal-Coolant
4	1-643161	1	Cap-Radiator
5	3296-2	1	Nut-Lock
6	1-803075	1	Screw-Head, Truss
7	103-1352	1	Shield-Fill Neck, Radiator
8	107-9889	1	Radiator
9	103-0898	1	Shroud-Cooling, Engine
10	322-3	16	Screw-HH
11	107-7717	1	Fan Mounting Plate ASM
11:2	1-643253	2	Decal-Fan, Radiator
12	32128-20	10	Nut-HF
13	103-0892	1	Fan
14	3296-42	1	Nut-Lock, NI
15	109-2670	1	Hose
16	1-513762	1	Clip-Loom
17	321-6	1	Screw-HH
18	103-0113	1	Clip-Loom
19	103-0922	1	Hose-Inlet, Engine
20	1-643164	1	Cap-Tank, Overflow
21	1-513645	1	Bushing-Valve, Fuel

Ref	Part No.	Qty.	Description
22	321-2	2	Screw-HH
23	1-643259	1	Fitting-Elbow
24	1-643163	1	Tank-Overflow
25	109-2669	1	Hose
26	1-633989	4	Clamp-Hose
27	103-2505	1	Hose-Outlet, Engine
28	103-0086-03	1	Mount-Motor, Fan
29	103-4986	1	Bracket-Deflector, Air
30	322-14	2	Screw-HH
31	3256-3	4	Washer-Flat
32	103-5223	2	Spacer
33	1-513296	2	Spring-Indicator, Reverse
34	3296-29	4	Nut-Lock, NI
35	107-9853	2	Lanyard
36	1-303287	3	Tie-Plastic
37	3245-44	1	Screw-Set
38	909848	1	Screw-Set
39	322-6	2	Screw-HH
40	1-303335	2	Tie-Plastic



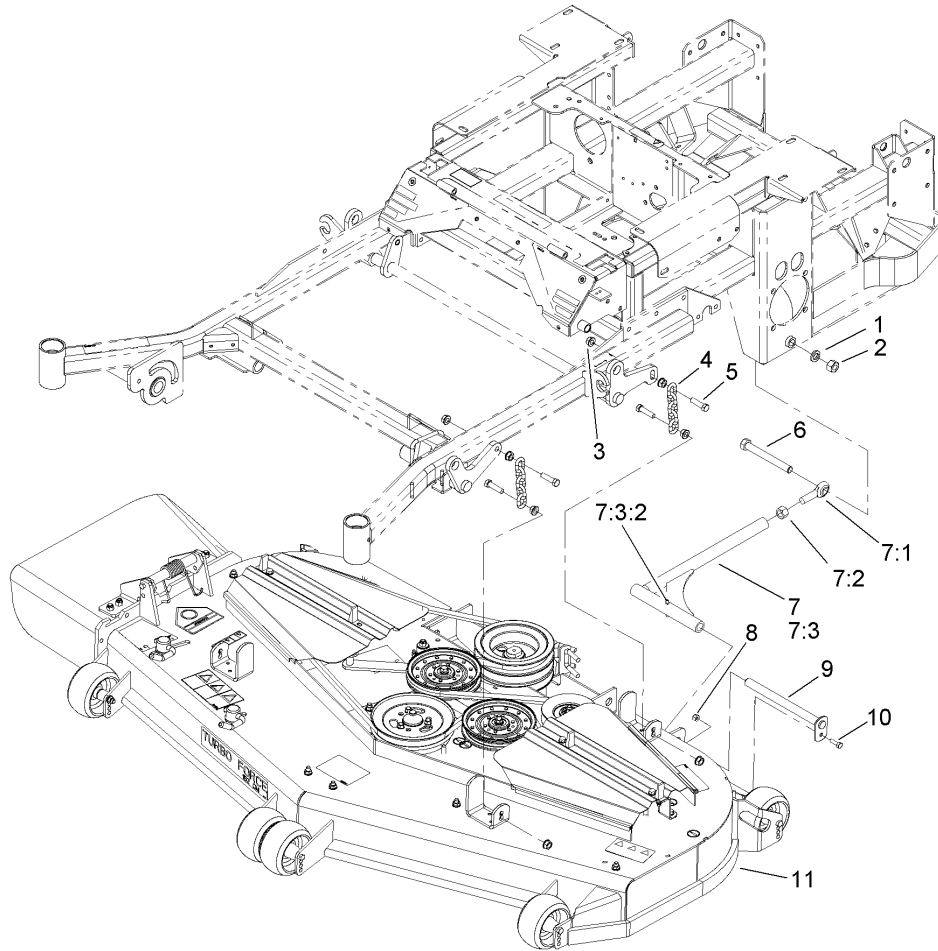

## Deck Connection Assembly

Ref	Part No.	Qty.	Description
1	3253-8	2	Washer-Lock
2	3217-11	2	Nut-Hex
3	32128-37	16	Nut-HF
4	1-633447	4	Chain-Lift, Deck
5	103-1898	8	Screw-HH
6	327-28	2	Screw-HH
7	103-1356	2	Strut ASM
7:1	1-633029	1	Balljoint-Spherical
7:2	3219-6	1	Nut-Hex
7:3		1	Strut-Deck
7:3:2	109-1380	2	Fitting-Grease
8	3296-29	2	Nut-Lock, NI
9	1-632199-01	2	Pin-Strut
10	322-3	2	Screw-HH
11		1	Deck ASM

--	--	--	--

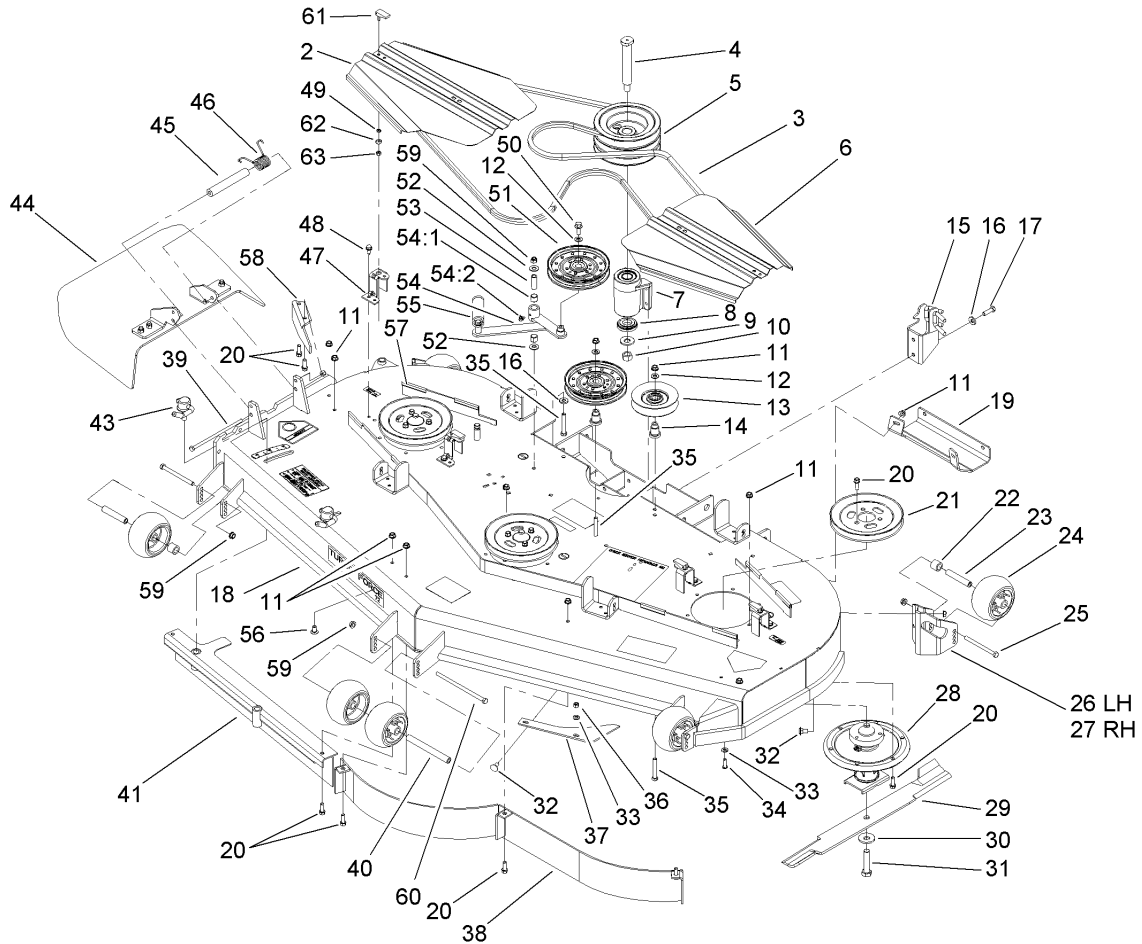

## Deck Assembly

Ref	Part No.	Qty.	Description
2	106-3275-03	1	Cover-Belt
3	107-7723	1	Belt-V
4	1-643393	1	Jackshaft
5	103-5381	1	Sheave-Jackshaft
6	105-8786-03	1	Cover-Belt
7	103-2544	1	Jackshaft ASM
8	103-2535	1	Spacer-Guard, Bottom
9	1-513208	1	Washer-Spring
10	3219-6	1	Nut-Hex
11	3290-357	36	Nut-HHF, Whiz
12	3256-24	3	Washer-Flat
13	1-603805	1	Pulley-Idler
14	106-3214	2	Mount-Pulley
15	103-3445-01	1	Guard-Jackshaft
16	98-5975	5	Washer-Belleville
17	323-7	4	Screw-HH
18	107-7677	1	Deck ASM
19	106-3279-01	1	Plate-Skid
20	92-1624	33	Screw
21	107-7678	3	Pulley
22	98-7913	4	Tube-Spacer
23	98-7912	4	Tube-Spinner
24	1-603299	6	Roller-Scalp, Anti
25	323-23	4	Screw-HH

Ref	Part No.	Qty.	Description
26	106-7354-01	1	Plate-Roller, LH
27	106-7355-01	1	Plate-Roller, RH
28	110-3933	3	Spindle Assembly
29	105-7784-03	3	Blade-Hi Flow, 24.5 Inch
30	103-0865	3	Washer-Blade Bolt, Heavy
31	103-0862	3	Screw-Cap
32	3231-1	10	Screw-CARR
33	1-303334	4	Washer-Spring
34	3274-104	2	Screw-HSBH
35	323-12	3	Screw-HH
36	3296-29	4	Nut-Lock, NI
37	107-3138	1	Plate-Turbo
38	105-7730-01	1	Baffle ASM
39	322-50	1	Screw-HH
40	98-5967	1	Spacer-Wheel
41	105-7669-01	1	Baffle ASM
43	107-1664	2	Lever ASM
44	108-2792	1	Rubber Deflector ASM
45	105-4622	1	Spacer
46	108-4052	1	Spring-Torsion
47	108-4121-01	4	Bracket-Cover
48	32144-70	4	Screw-HWHTF
49	99-3058	4	Washer
50	3234-11	1	Screw-HHF

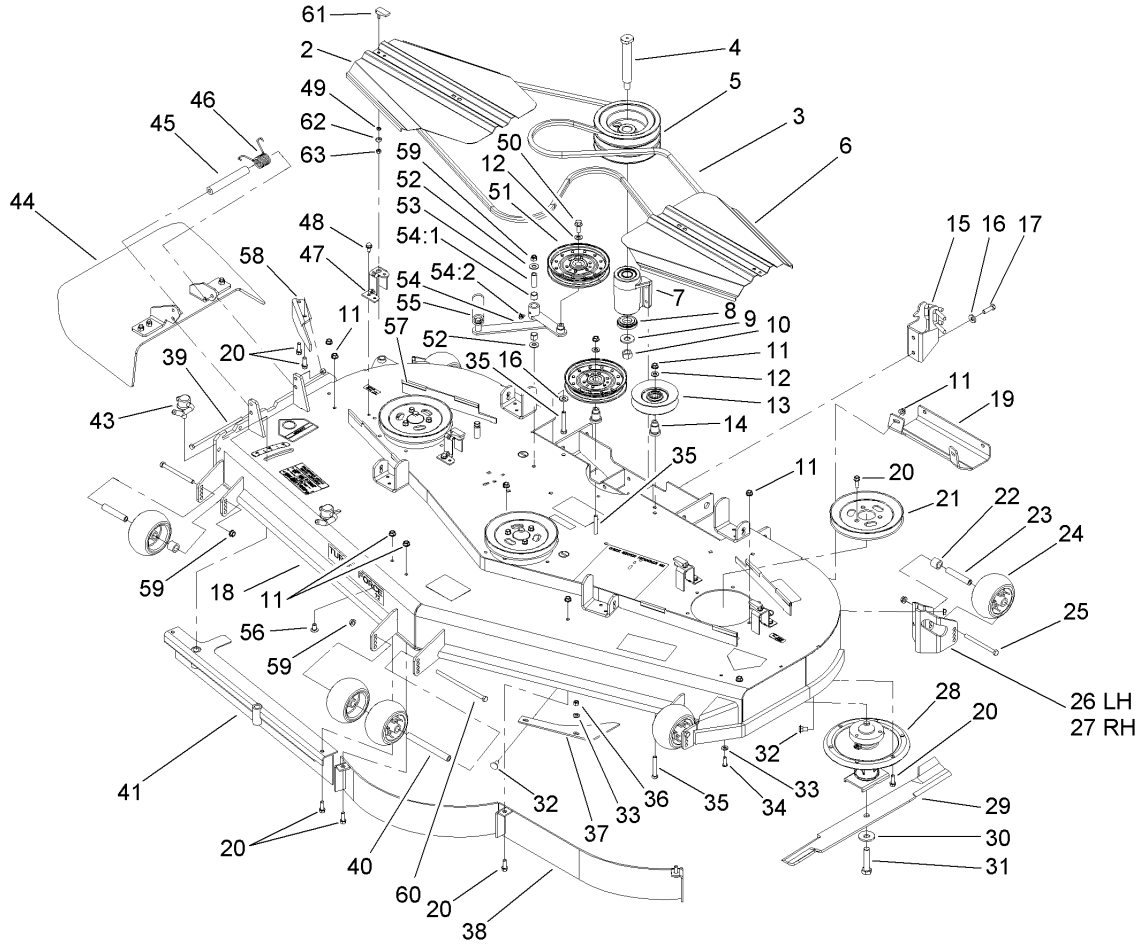

### Deck Assembly (continued)

Ref	Part No.	Qty.	Description
51	1-633109	2	Idler-Flat
52	3256-4	2	Washer-Flat
53	1-603044	1	Bushing
54	107-9868	1	Idler Arm ASM
54:1	103-4681	2	Sleeve-Bearing
54:2	302-40	1	Fitting-Grease
55	105-6992	1	Spring
56	3231-21	1	Screw-CARR
57	105-7699	8	Strip-Seal
58	106-3216-01	1	Baffle-Discharge
59	3296-39	6	Nut-Lock, NI
60	323-28	1	Screw-HH
61	106-6777	4	Handle-Latch, Swell
62	106-6778	4	Bushing-Latch, Swell
63	1-804254	4	Nut

--	--	--	--



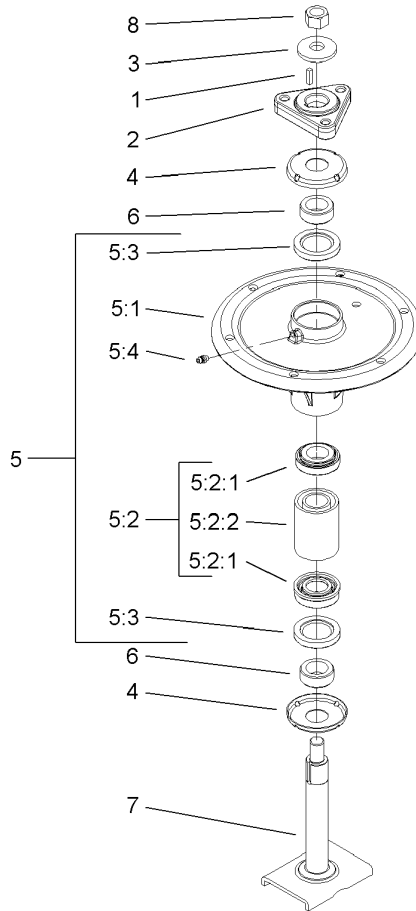

### Spindle Assembly No. 110-3933

Ref	Part No.	Qty.	Description
1	10-8040	1	Key-Square
2	108-7793	1	Hub-Pulley
3	103-0865	1	Washer-Blade Bolt, Heavy
4	106-3204	2	Shield-Bearing
5		1	Spindle Bearing ASM
5:1	106-3211	1	Housing-Spindle
5:2	108-7711	1	Bearing ASM
5:2:1	108-7710	1	Bearing ASM
5:2:2	106-3206	1	Spacer-Set, Matched
5:3	253-133	2	Seal-Oil
5:4	302-5	1	Fitting-Grease
6	106-3218	2	Spacer-Seal
7	106-3233	1	Spindle Shaft ASM
8	3219-6	1	Nut-Hex





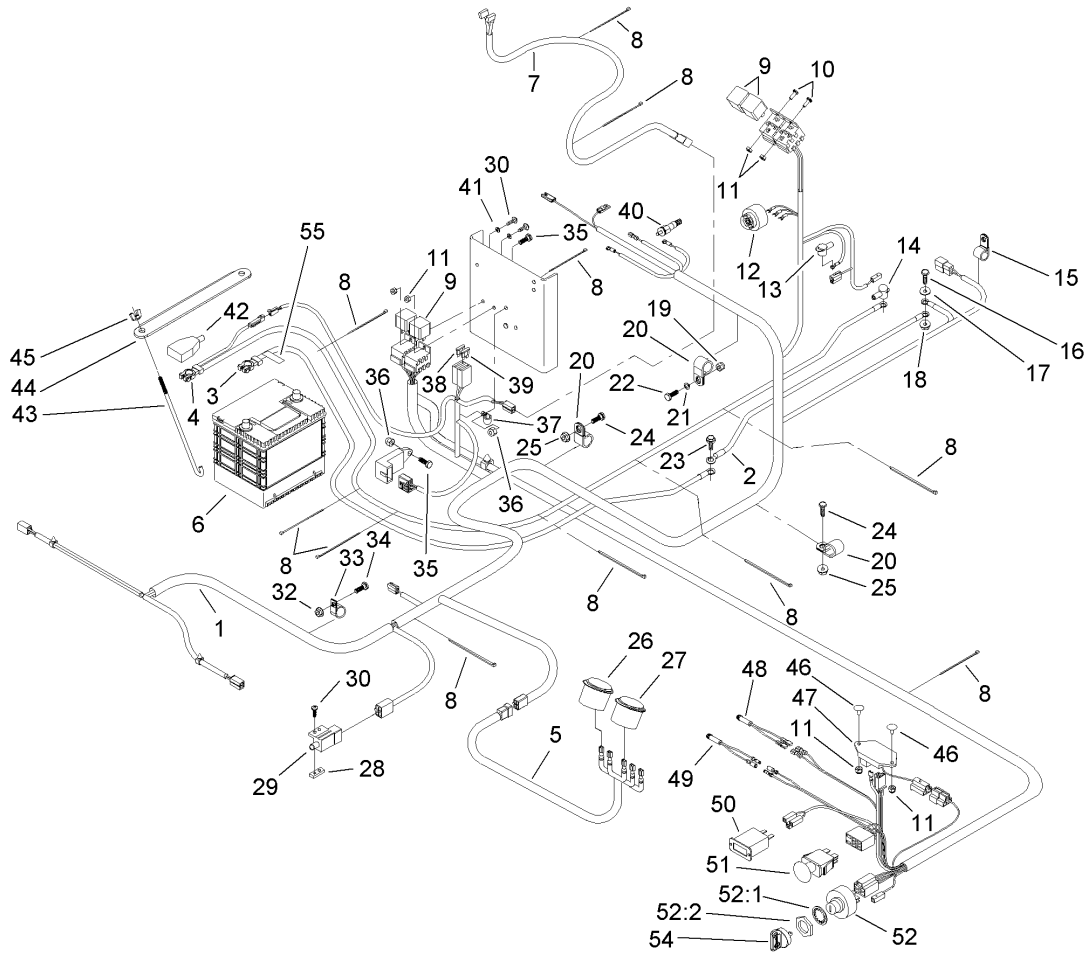

## Electrical Assembly

Ref	Part No.	Qty.	Description
1	103-4340	1	Harness-Wire
2	103-1349	1	Cable-Engine Negative
3	103-1159	1	Cable-Battery Negative
4	103-1160	1	Cable-Starter
5	103-4339	1	Harness-Gauge
6	106-5187	1	Battery
7	103-1227	1	Harness-Wiring, Seat
8	1-303335	11	Tie-Plastic
9	1-643275	4	Relay
10	1-803071	2	Screw
11	3296-2	8	Nut-Lock
12	103-0205	1	Alarm-Tone, Dual
13	1-643178	1	Cap-Insulator, Red
14	103-1420	1	Insulator-Starter
15	1-603727	1	Clip-Loom
16	323-6	1	Screw-HH
17	3256-24	1	Washer-Flat
18	3290-357	1	Nut-HHF, Whiz
19	33023-00	1	Nut-Lock
20	1-633396	3	Clip-Loom
21	3256-22	1	Washer-Flat
22	33113-020	1	Screw-HH
23	32144-70	1	Screw-HWHTF
24	322-3	2	Screw-HH

Ref	Part No.	Qty.	Description
25	32128-20	2	Nut-HF
26	1-643037	1	Gauge-Voltmeter
27	1-643021	1	Gauge-Temperature
28	1-633181	1	Plate-Tapped
29	1-633111	1	Switch
30	3290-500	4	Screw-PPH
32	32128-33	1	Nut-HF
33	1-323229	1	Clip-Loom
34	321-2	1	Screw-HH
35	321-4	3	Screw-HH
36	3296-42	2	Nut-Lock, NI
37	1-513762	1	Clip-Loom
38	1-816001	1	Fuse-Blade Type, 20 Amp
39	103-1368	1	Fuse-40 Amp
40	103-0949	1	Sender-Temperature
41	3256-14	2	Washer-Flat
42	103-1340	1	Insulator-Terminal, Battery
43	103-1312	2	Bolt-Holddown
44	103-1311-03	1	Holddown-Battery
45	1-543792	2	Wingnut
46	1-807513	2	Bolt-CARR
47	103-5218	1	Module-Delay, Seat
48	1-643267	1	Indicator-Led, Red
49	103-1320	1	Indicator-Led, Amber

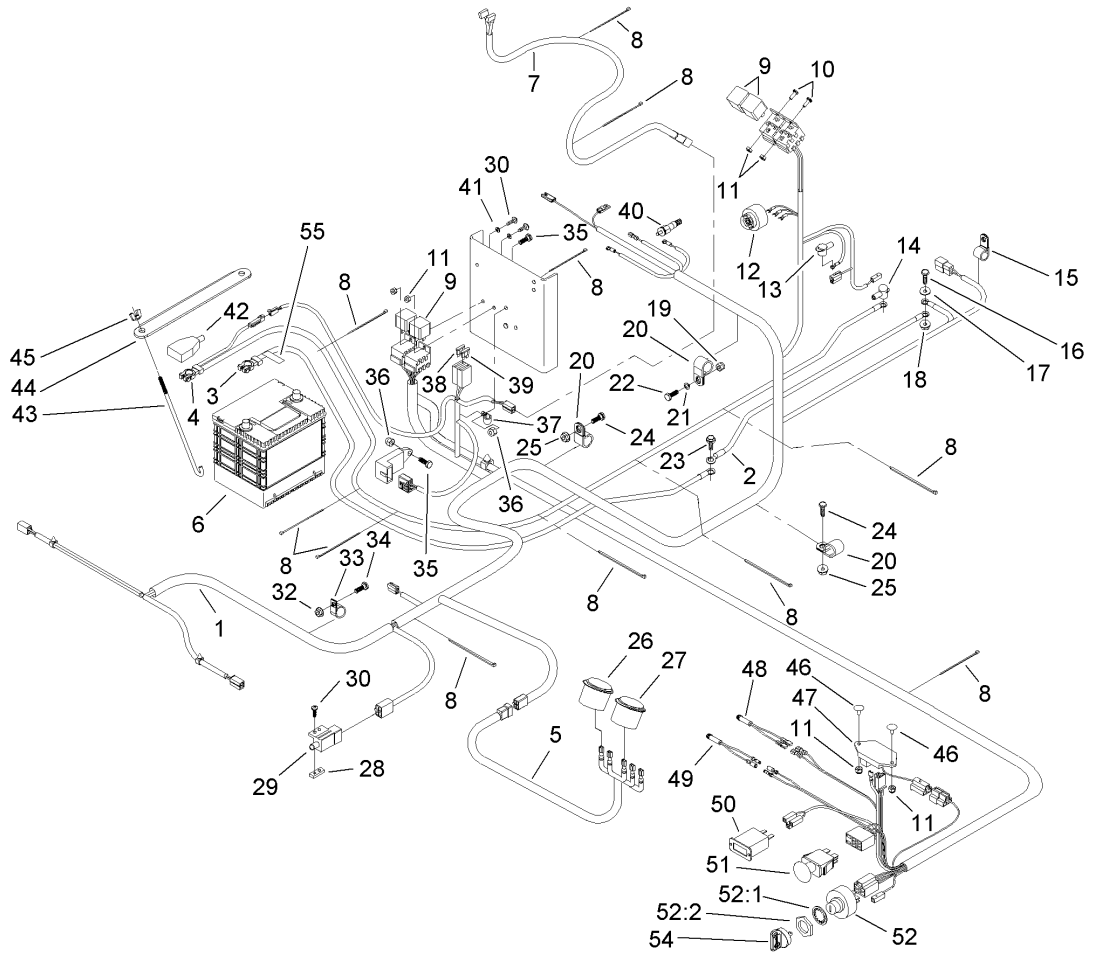

### Electrical Assembly (continued)

Ref	Part No.	Qty.	Description
50	1-513374	1	Meter-Hour
51	103-5221	1	Switch-PTO
52	103-0206	1	Switch-Starting, Key
52:1	3254-5	1	Washer-Tooth
52:2	218-461	1	Nut-HH
54	63-8360	2	Key-Ignition
55	107-9309	1	Decal-Instructions, Charging

--	--	--	--

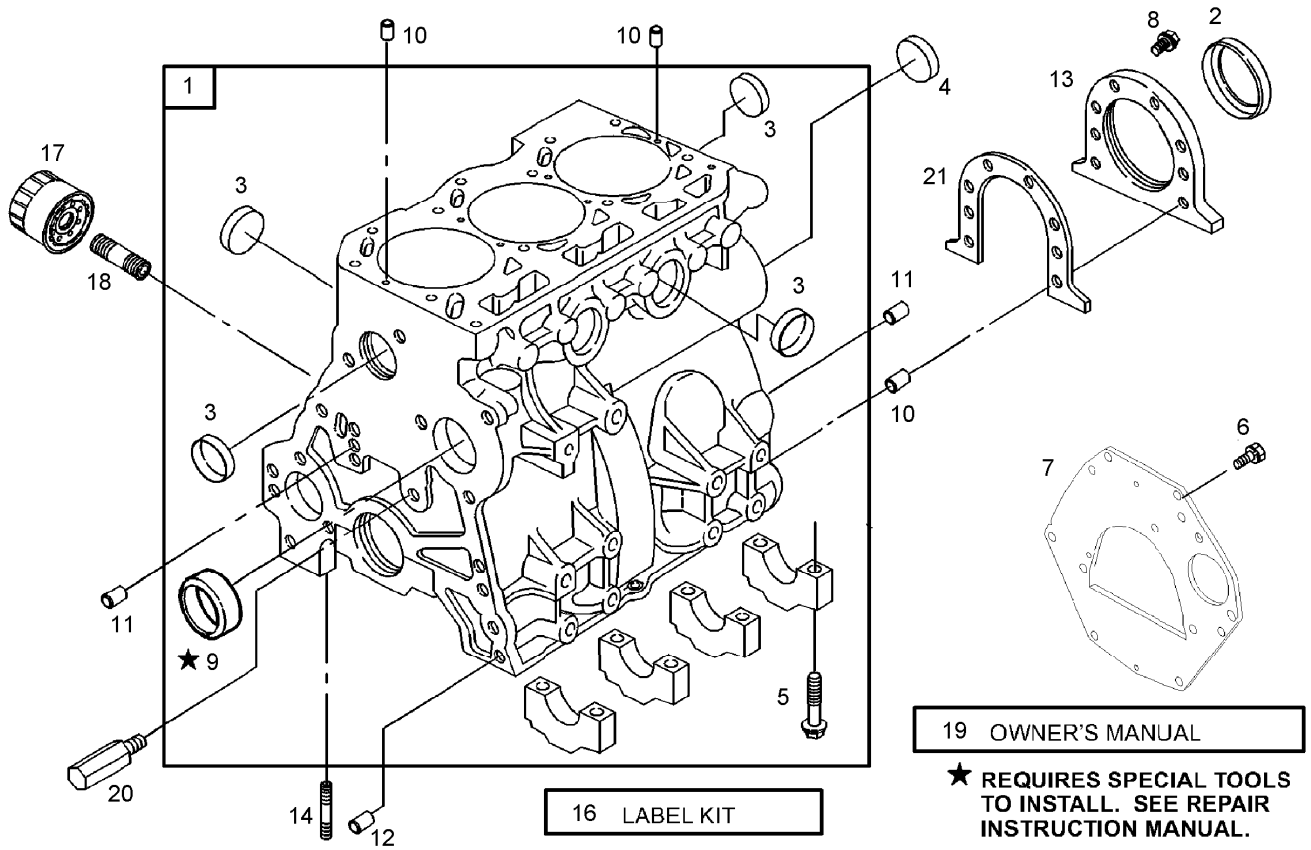

Assemblies include all parts shown in frames.

## Cylinder Assembly

Ref	Part No.	Qty.	Description
1	107-9891	1	Cylinder ASM
2	99-9003	1	Seal-Oil
3	99-9008	1	Plug-Welch
4	107-9892	1	Plug-Welch (Cam)
5	99-9006	1	Screw-Hex
6	99-9005	1	Screw-Hex
7	107-9893	1	Plate-End, Rear
8	99-9004	1	Screw-Hex
9	99-9002	1	Bushing
10	99-9012	1	Pin-Locating
11	99-9013	1	Pin-Locating
12	99-9014	1	Pin-Locating
13	99-9022	1	Retainer-Seal
14	99-9007	1	Stud-Metric
16	107-9894	1	Kit-Label
17	99-9017	1	Filter-Oil
18	105-9337	1	Adapter-Filter, Oil
19	103-1384	1	Manual-Engine
20	99-9020	1	Nozzle-Oil
21	99-9021	1	Gasket-Retainer

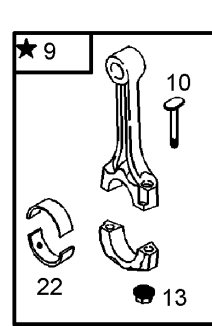
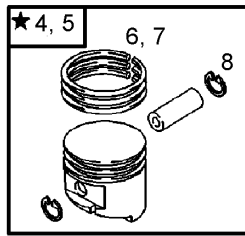
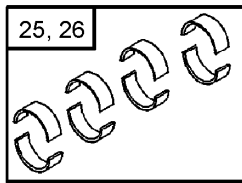
★ REQUIRES SPECIAL TOOLS TO INSTALL. SEE REPAIR INSTRUCTION MANUAL.

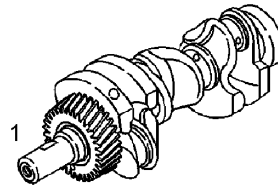
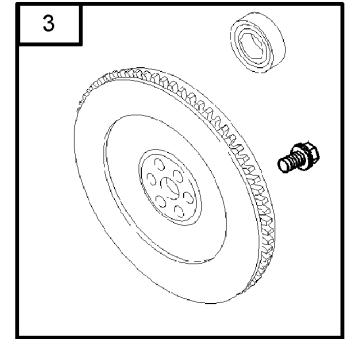
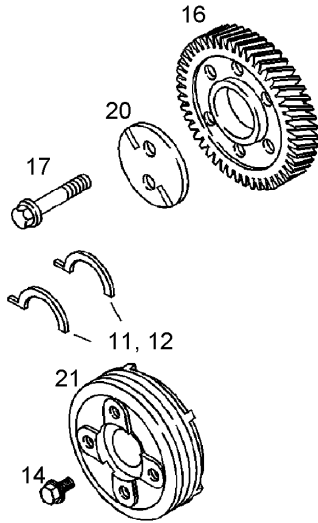
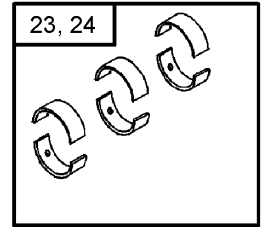

Assemblies include all parts shown in frames.

## Crankshaft Assembly

Ref	Part No.	Qty.	Description
1	105-9339	1	Crankshaft
3	99-9024	1	Flywheel
4	107-9895	1	Piston ASM
5	107-9896	1	Piston ASM (Oversize)
6	105-9340	1	Ring Set
7	99-9269	1	Ring Set (.010 In Oversized)
8	99-9607	1	Lock-Pin, Piston
9	99-9608	1	Rod-Connecting
10	99-9030	1	Screw-Rod, Connecting
11	99-9035	1	Washer-Thrust
12	99-9036	1	Washer-Thrust (.005 In Oversized)
13	99-9034	1	Nut-Hex
14	107-9897	1	Screw-Hex
15	99-9037	1	Pin-Locating
16	99-9609	1	Gear-Drive
17	99-9032	1	Screw-Hex
20	99-9040	1	Plate-Gear, Idler
21	99-9041	1	Pulley-Crankshaft
22	99-9042	1	Bearing-Rod
23	99-9043	1	Set-Bearing, Rod
24	99-9044	1	Set-Bearing, Rod (.010 Undersized)
25	99-9045	1	Set-Bearing, Main (Set Of 8)

Ref	Part No.	Qty.	Description
26	99-9046	1	Set-Bearing, Main (.010 Undersized)

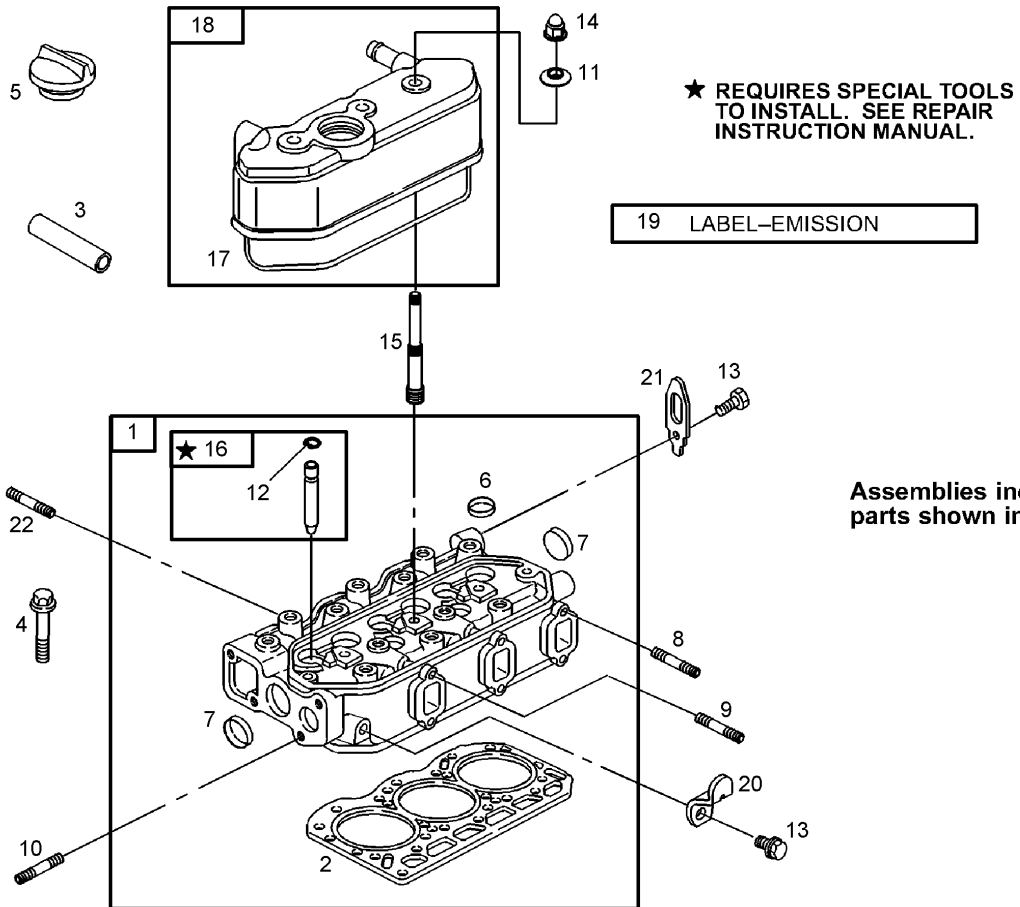

## Cylinder Head Assembly

Ref	Part No.	Qty.	Description				
1	105-9341	1	Head-Cylinder				
2	107-9898	1	Gasket-Head, Cylinder				
3	105-9342	1	Tube-Breather				
4	99-9614	1	Screw-Metric				
5	99-9052	1	Cap-Fill, Oil				
6	99-9060	1	Plug-Welch				
7	99-9008	1	Plug-Welch				
8	99-9058	1	Stud-Metric				
9	99-9059	1	Stud-Metric				
10	99-9057	1	Stud-Metric				
11	99-9063	1	Washer-Seal				
12	99-9067	1	Retainer				
13	99-9054	1	Screw-Hex				
14	99-9061	1	Nut-Hex, Metric				
15	99-9101	1	Stud-Arm, Rocker				
16	99-9070	1	Bushing-Guide				
17	99-9073	1	Gasket-Cover, Rocker				
18	100-6402	1	Cover-Rocker				
19	107-9899	1	Emmision Label Kit				
20	99-9076	1	Bracket-Lifting				
21	99-9077	1	Bracket-Lifting				
22	99-9055	1	Stud-Metric				

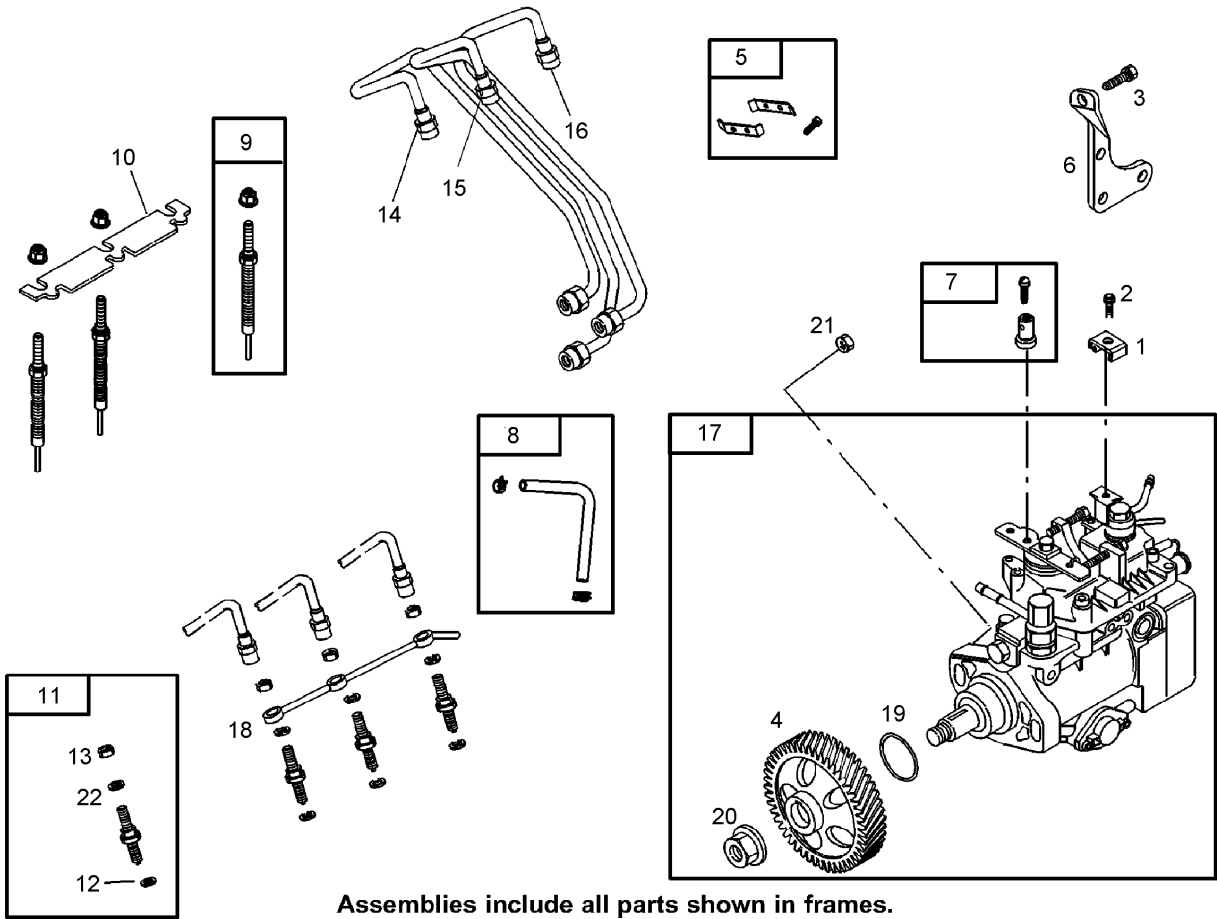

Assemblies include all parts shown in frames.

## Injection Pump Assembly

Ref	Part No.	Qty.	Description
1	99-9622	1	Clamp-Casing
2	99-9056	1	Screw-Hex
3	99-9616	1	Screw-Hex
4	99-9689	1	Gear-Drive
5	99-9625	1	Clamp
6	99-9626	1	Bracket-Support
7	99-9628	1	Clamp-Swivel
8	99-9629	1	Hose / Clamp ASM
9	99-9630	1	Plug-Glow
10	99-9631	1	Strap-Plug, Glow
11	99-9632	1	Nozzle-Injector
12	99-9633	1	Seat-Injector
13	105-9345	1	Nut
14	99-9690	1	Pipe-Injector, No. 1
15	99-9634	1	Pipe-Injector, No. 2
16	99-9635	1	Pipe-Injector, No. 3
17	105-9334	1	Pump-Injection
18	99-9637	1	Pipe-Return, Fuel
19	99-9618	1	O-Ring
20	99-9620	1	Nut-Hex, Metric
21	99-9619	1	Nut-Hex, Metric
22	105-9343	1	Seat-Injector

--	--	--	--

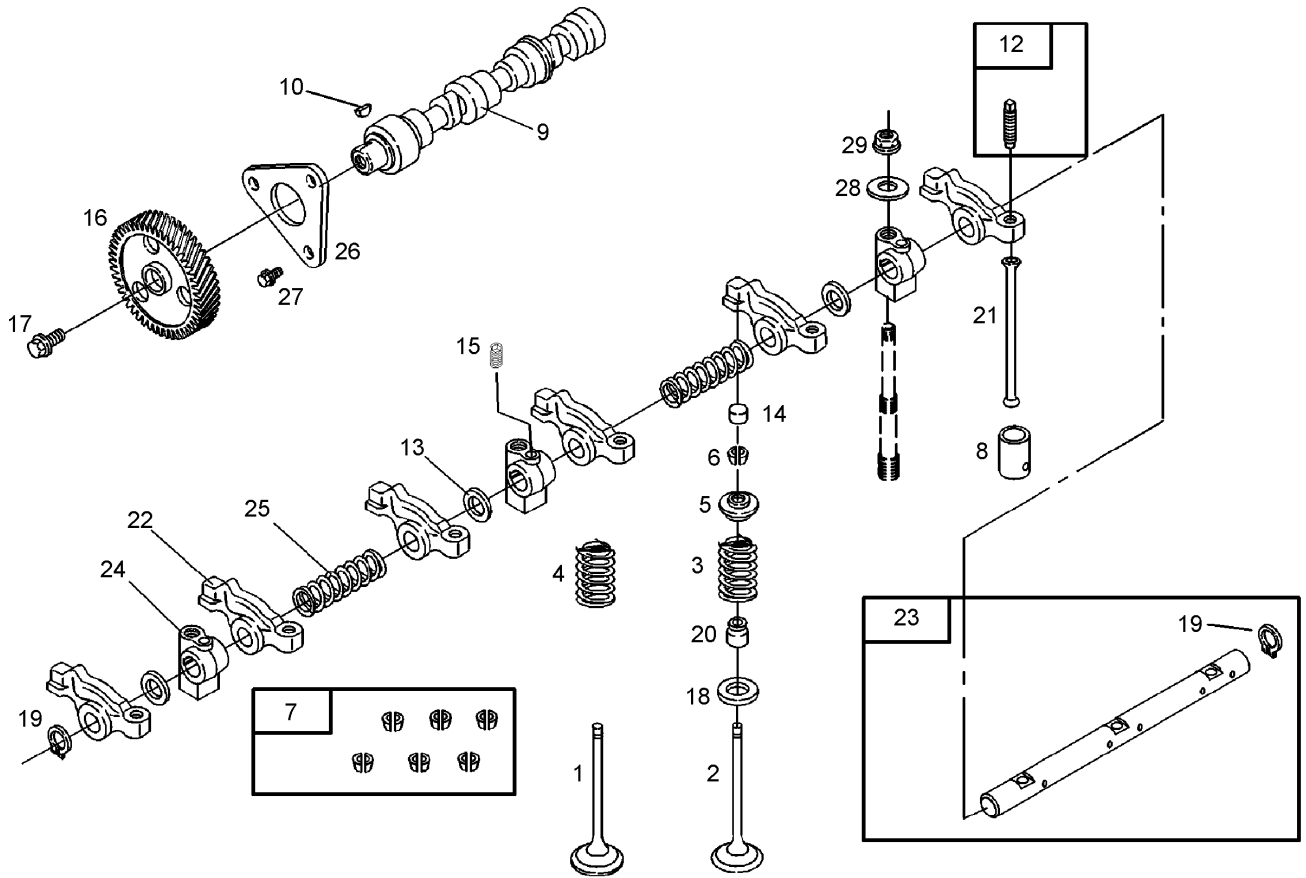

Assemblies include all parts shown in frames.

## Camshaft Assembly

Ref	Part No.	Qty.	Description
1	99-9638	1	Valve-Exhaust
2	99-9639	1	Valve-Intake
3	99-9640	1	Spring-Valve
4	99-9640	1	Spring-Valve
5	99-9084	1	Retainer-Valve
6	99-9086	1	Keeper-Valve (Set)
7	99-9087	1	Keeper-Valve (Set Of 6)
8	99-9088	1	Tappet-Valve
9	99-9097	1	Shaft-Cam
10	99-9675	1	Key-Timing
12	99-9092	1	Adjuster-Arm, Rocker
13	99-9093	1	Washer-Spacer
14	99-9094	1	Cap-Valve
15	99-9090	1	Screw-Metric
16	99-9641	1	Gear-Cam
17	99-9085	1	Screw-Metric
18	99-9096	1	Seat-Spring, Valve
19	99-9099	1	Retainer
20	99-9643	1	Seal-Valve
21	99-9103	1	Rod-Push
22	99-9104	1	Arm-Rocker
23	99-9106	1	Shaft-Arm, Rocker
24	99-9107	1	Support-Arm, Rocker
25	99-9108	1	Spring-Shaft, Rocker

Ref	Part No.	Qty.	Description
26	99-9109	1	Retainer-Camshaft
27	99-9083	1	Screw-Hex
28	99-9079	1	Washer-Flat
29	99-9091	1	Nut-Hex, Metric





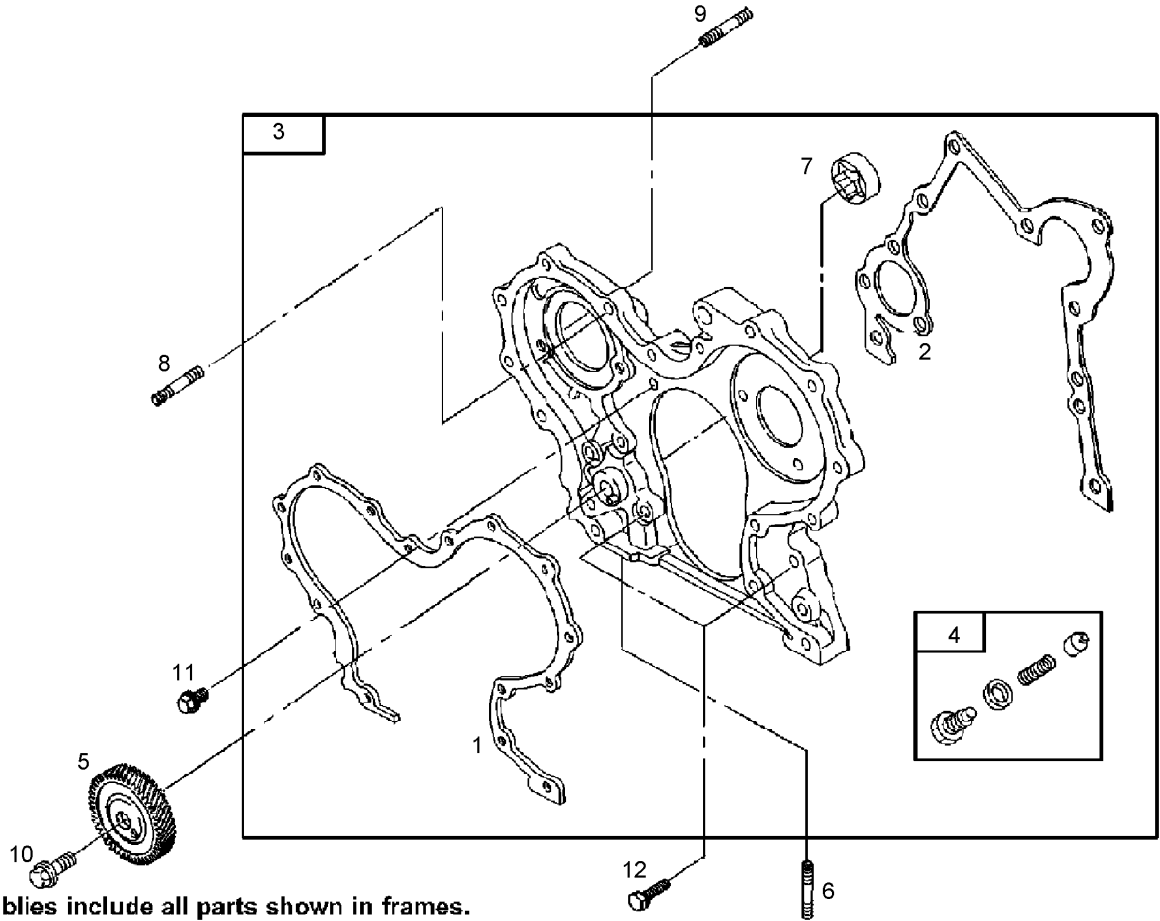

## Gear Housing Assembly

Ref	Part No.	Qty.	Description	
1	99-9653	1	Gasket-Cover, Gear	
2	99-9136	1	Gasket-Cover, Gear	
3	99-9655	1	Housing-Gear	
4	99-9142	1	Valve-Relief, Oil	
5	99-9656	1	Gear-Drive	
6	99-9007	1	Stud-Metric	
7		1	Pump-Oil	
8	99-9137	1	Stud-Metric	
9	99-9654	1	Stud-Metric	
10	99-9135	1	Screw-Hex	
11	99-9134	1	Screw-Hex	
12	99-9133	1	Screw-Hex	

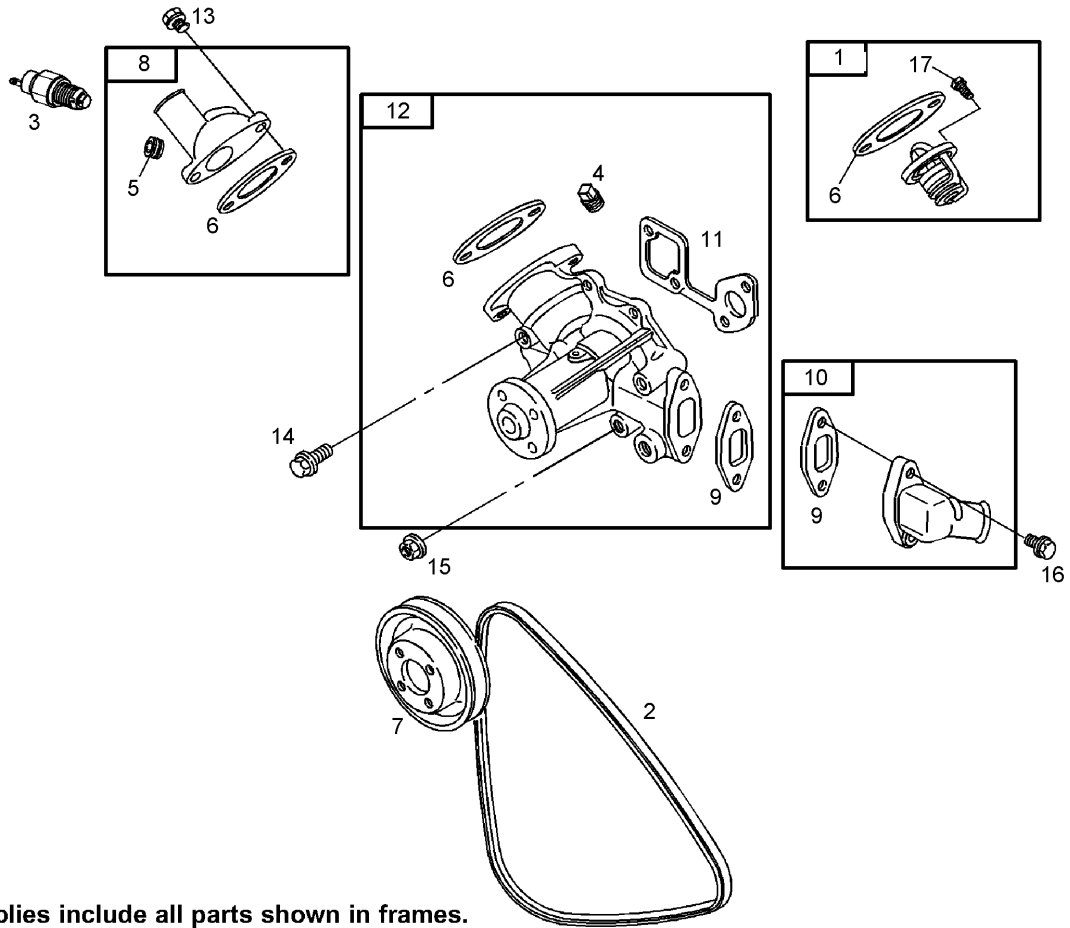

Assemblies include all parts shown in frames.

## Water Pump Assembly

Ref	Part No.	Qty.	Description
1	99-9155	1	Thermostat
2	99-9156	1	Belt-V
3	107-9902	1	Switch-Temperature, Water
4	99-9159	1	Plug
5	99-9158	1	Plug
6	99-9163	1	Gasket-Outlet
7	99-9164	1	Pulley-Pump
8	99-9165	1	Housing-Outlet
9	99-9166	1	Gasket-Housing, Inlet
10	99-9167	1	Housing-Inlet
11	99-9168	1	Gasket-Pump, Water
12	99-9659	1	Pump-Water
13	99-9004	1	Screw-Hex
14	99-9151	1	Screw-Hex
15	99-9153	1	Nut-Hex, Metric
16	99-9004	1	Screw-Hex
17	99-9152	1	Screw-Metric

--	--	--	--







# Attachments and Accessories

## For 74269 - Z597-D Z Master, With 72in TURBO FORCE Side Discharge Mower

Product Name	Model/Part
Filter-Hydraulic, Winter	1-633752
Blade-Mid Flow, 24.5 Inch	105-7711-03
Blade-Lo Flow, 24.5 Inch	105-7712-03
Blade-Atomic, 24.5 Inch	105-7719-03
Blade-Recycler, 24.5 Inch	105-7778-03
72 Inch Recycler Kit	107-1612
Striping Kit	107-1630
Turbo Baffle Kit	107-1634
Light Kit	107-9880
6 Pack Blade, 24.5 Inch Hi-Flow	108-1120
6 Pack Blade, 24.5 Inch Atomic	108-1126
Roller Striping Kit	108-2162
6 Pack-Blade, 24.5 Inch Mid-Flow	110-0404
6 Pack-Blade, 24.5 Inch Lo-Flow	110-0410
Hitch Kit	110-0444
Cool Top-Rops Mounted Fan	110-1996
Sunshade-Bimini	110-5726
Channel Reinforcement Kit	112-8674
Wheel Spacer Kit	112-8699
Chute Gate Kit	78521
72 Inch Deck Triple Bag Assembly	78535
72 Inch Blower and Drive Kit	78539
Filter Minder Gauge	99-4664

