



**Count on it.**

**Operator's Manual**

**Z453 Z Master<sup>®</sup> with 48in  
or 52in TURBO FORCE<sup>®</sup> Side  
Discharge Mower**

**Model No. 74416—Serial No. 260000001 and Up**

**Model No. 74417—Serial No. 260000001 and Up**

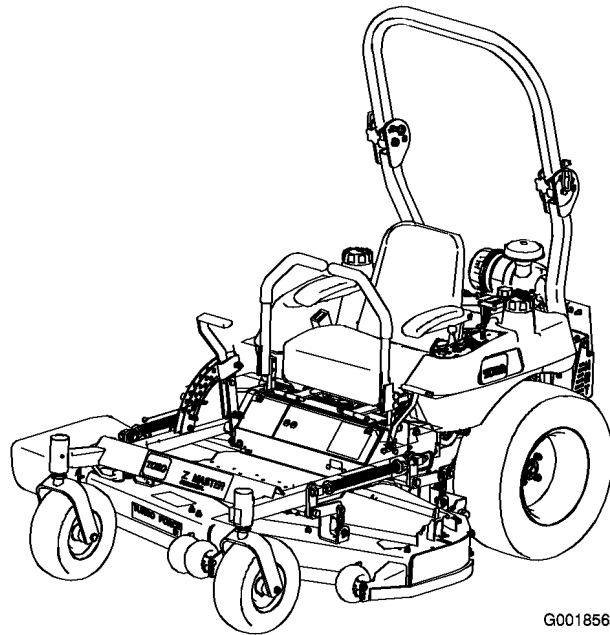

G001856

## Warning

### CALIFORNIA Proposition 65 Warning

The engine exhaust from this product contains chemicals known to the State of California to cause cancer, birth defects, or other reproductive harm.

**Important:** This engine is not equipped with a spark arrester muffler. It is a violation of California Public Resource Code Section 4442 to use or operate the engine on any forest-covered, brush-covered, or grass-covered land. Other states or federal areas may have similar laws.

This spark ignition system complies with Canadian ICES-002

The enclosed Engine Owner's Manual is supplied for information regarding the US Environmental Protection Agency (EPA) and the California Emission Control Regulation of emission systems, maintenance, and warranty. Replacements may be ordered through the engine manufacturer.

## Introduction

Read this information carefully to learn how to operate and maintain your product properly and to avoid injury and product damage. You are responsible for operating the product properly and safely.

You may contact Toro directly at [www.Toro.com](http://www.Toro.com) for product and accessory information, help finding a dealer, or to register your product.

Whenever you need service, genuine Toro parts, or additional information, contact an Authorized Service Dealer or Toro Customer Service and have the model and serial numbers of your product ready. Figure 1 identifies the location of the model and serial numbers on the product. Write the numbers in the space provided.

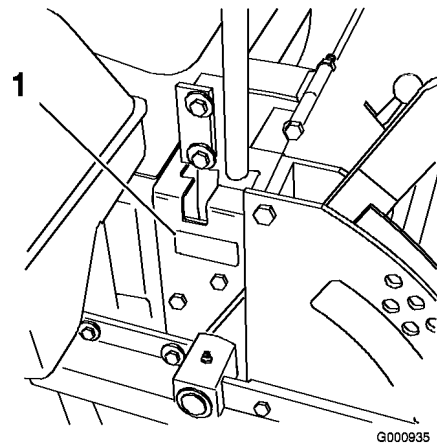

Figure 1

1. Model and serial number location

Model No. _____
Serial No. _____

This manual identifies potential hazards and has safety messages identified by the safety alert symbol (Figure 2), which signals a hazard that may cause serious injury or death if you do not follow the recommended precautions.



Figure 2

1. Safety alert symbol

This manual uses 2 other words to highlight information. **Important** calls attention to special mechanical information and **Note** emphasizes general information worthy of special attention.

## Contents

Introduction .....	2
Safety .....	4
Safe Operating Practices .....	4
Slope Chart .....	7
Safety and Instructional Decals .....	8
Product Overview .....	13
Controls .....	13
Operation.....	14
Adding Fuel .....	14
Checking the Engine Oil Level .....	15

Using the Rollover Protection System (ROPS).....	15	Adjusting the Parking Brake.....	38
Think Safety First.....	16	Belt Maintenance.....	38
Operating the Parking Brake.....	17	Inspecting the Belts.....	38
Starting and Stopping the Engine.....	17	Replacing the Mower Belt.....	39
Operating the Power Take Off (PTO).....	19	Replacing the Pump Drive Belt.....	39
The Safety Interlock System.....	19	Adjusting the Push Arms.....	40
Driving Forward or Backward.....	20	Controls System Maintenance.....	40
Stopping the Machine.....	21	Adjusting the Control Handle Neutral Position.....	40
Adjusting the Height-of-Cut.....	21	Hydraulic System Maintenance.....	41
Adjusting the Anti-Scalp Rollers.....	21	Servicing the Hydraulic System.....	41
Adjusting the Flow Baffle.....	22	Setting the Hydraulic Pump Neutral Position.....	43
Positioning the Flow Baffle.....	22	Mower Deck Maintenance.....	45
Positioning the Seat.....	23	Leveling the Mower at Three Positions.....	45
Unlatching the Seat.....	23	Servicing the Cutting Blades.....	47
Pushing the Machine by Hand.....	24	Replacing the Grass Deflector.....	50
Using the Side Discharge.....	24	Cleaning.....	50
Transporting Machines.....	24	Cleaning Under the Mower.....	50
Loading Machines.....	25	Waste Disposal.....	50
Operating Tips.....	26	Storage.....	51
Maintenance.....	27	Troubleshooting.....	52
Recommended Maintenance Schedule(s).....	27	Schematics.....	55
Lubrication.....	28		
Greasing and Lubrication.....	28		
Greasing the Mower Deck and Belt Idlers.....	28		
Engine Maintenance.....	29		
Servicing the Air Cleaner.....	29		
Servicing the Engine Oil.....	30		
Servicing the Spark Plugs.....	32		
Fuel System Maintenance.....	32		
Replacing the Fuel Filter.....	32		
Servicing the Fuel Tank.....	33		
Electrical System Maintenance.....	33		
Servicing the Battery.....	33		
Servicing the Fuses.....	35		
Drive System Maintenance.....	36		
Adjusting the Tracking.....	36		
Checking the Tire Pressure.....	36		
Checking the Wheel Hub Slotted Nut.....	36		
Adjusting the Caster Pivot Bearing.....	37		
Cooling System Maintenance.....	37		
Cleaning the Air Intake Screen.....	37		
Cleaning the Cooling System.....	37		
Brake Maintenance.....	38		

# Safety

Improper use or maintenance by the operator or owner can result in injury. To reduce the potential for injury, comply with these safety instructions and always pay attention to the safety alert symbol, which means **CAUTION, WARNING, or DANGER**-“personal safety instruction.” Failure to comply with the instruction may result in personal injury or death.

This product is capable of amputating hands and feet and throwing objects. Always follow all safety instructions to avoid serious injury or death.

This product is designed for cutting and recycling grass or, when equipped with a grass bagger, for catching cut grass. Any use for purposes other than these could prove dangerous to user and bystanders.

## Safe Operating Practices

The following instructions are from ANSI standard B71.4-2004.

### Training

- Read the Operator’s Manual and other training material. If the operator(s) or mechanic(s) can not read English it is the owner’s responsibility to explain this material to them.
- Become familiar with the safe operation of the equipment, operator controls, and safety signs.
- All operators and mechanics should be trained. The owner is responsible for training the users.
- Never let children or untrained people operate or service the equipment. Local regulations may restrict the age of the operator.
- The owner/user can prevent and is responsible for accidents or injuries occurring to himself or herself, other people or property.

### Preparation

- Evaluate the terrain to determine what accessories and attachments are needed to properly and safely perform the job. Only use accessories and attachments approved by the manufacturer.
- Wear appropriate clothing including hard hat, safety glasses and hearing protection. Long

hair, loose clothing or jewelry may get tangled in moving parts.

- Inspect the area where the equipment is to be used and remove all objects such as rocks, toys and wire which can be thrown by the machine.
- Use extra care when handling gasoline and other fuels. They are flammable and vapors are explosive.
  - Use only an approved container
  - Never refuel or drain the machine indoors.
  - Never remove gas cap or add fuel with engine running. Allow engine to cool before refueling. Do not smoke.
- Check that operator’s presence controls, safety switches and shields are attached and functioning properly. Do not operate unless they are functioning properly.

### Operation

- Never run an engine in an enclosed area.
- Only operate in good light, keeping away from holes and hidden hazards.
- Be sure all drives are in neutral and parking brake is engaged before starting engine. Start the engine only from the operator’s position.
- Never raise mower with the blades running.
- Never operate without the PTO shield, or other guards securely in place. Be sure all interlocks are attached, adjusted properly, and functioning properly.
- Never operate with the discharge deflector raised, removed or altered, unless using a grass catcher.
- Do not change the engine governor setting or overspeed the engine.
- Stop on level ground, lower implements, disengage drives, engage parking brake, shut off engine before leaving the operator’s position for any reason including emptying the catchers or unclogging the chute.
- Stop equipment and inspect blades after striking objects or if an abnormal vibration occurs. Make necessary repairs before resuming operations.
- Keep hands and feet away from the cutting units.

- Never carry passengers and keep pets and bystanders away.
- Be alert, slow down and use caution when making turns. Look behind and to the side before changing directions.
- Slow down and use caution when crossing roads and sidewalks. Stop blades if not mowing.
- Be aware of the mower discharge direction and do not point it at anyone.
- Do not operate the mower under the influence of alcohol or drugs.
- Use extreme care when loading or unloading the machine into a trailer or truck.
- Use care when approaching blind corners, shrubs, trees, or other objects that may obscure vision.

### **Slope Operation**

- Do not mow slopes greater than 15 degrees.
- Do not mow near drop-offs, ditches, steep banks or water. Wheels dropping over edges can cause rollovers, which may result in serious injury, death or drowning.
- Do not mow slopes when grass is wet. Slippery conditions reduce traction and could cause sliding and loss of control.
- Do not make sudden turns or rapid speed changes.
- Use a walk behind mower and/or a hand trimmer near drop-offs, ditches, steep banks or water.
- Reduce speed and use extreme caution on slopes.
- Remove or mark obstacles such as rocks, tree limbs, etc. from the mowing area. Tall grass can hide obstacles.
- Watch for ditches, holes, rocks, dips, and rises that change the operating angle, as rough terrain could overturn the machine.
- Avoid sudden starts when mowing uphill because the mower may tip backwards.
- Be aware that loss of traction may occur going downhill. Weight transfer to the front wheels may cause drive wheels to slip and cause loss of braking and steering.

- Always avoid sudden starting or stopping on a slope. If tires lose traction, disengage the blades and proceed slowly off the slope.
- Follow the manufacturer's recommendations for wheel weights or counterweights to improve stability.
- Use extreme care with grass catchers or other attachments. These can change the stability of the machine and cause loss of control.

### **Using the Rollover Protection System (ROPS)**

- Keep the roll bar in the raised and locked position and use the seat belt when operating the machine.
- Be certain that the seat belt can be released quickly in the event of an emergency.
- Be aware there is no rollover protection when the roll bar is down.
- Check the area to be mowed and never fold the ROPS in areas where there are slopes, drop offs or water.
- Lower the rollbar only when absolutely necessary. Do not wear the seat belt with the roll bar folded down.
- Check carefully for overhead clearances (i.e. branches, doorways, electrical wires) before driving under any objects and do not contact them.

### **Maintenance and storage**

- Disengage drives, lower implement, set parking brake, stop engine and remove key or disconnect spark plug wire. Wait for all movement to stop before adjusting, cleaning or repairing.
- Clean grass and debris from cutting units, drives, mufflers, and engine to help prevent fires. Clean up oil or fuel spillage.
- Let engine cool before storing and do not store near flame.
- Shut off fuel while storing or transporting. Do not store fuel near flames or drain indoors.
- Park machine on level ground. Never allow untrained personnel to service machine.
- Use jack stands to support components when required.

- Carefully release pressure from components with stored energy.
- Disconnect battery or remove spark plug wire before making any repairs. Disconnect the negative terminal first and the positive last. Reconnect positive first and negative last.
- Use care when checking blades. Wrap the blade(s) or wear gloves, and use caution when servicing them. Only replace blades. Never straighten or weld them.
- Keep hands and feet away from moving parts. If possible, do not make adjustments with the engine running.
- Charge batteries in an open well ventilated area, away from spark and flames. Unplug charger before connecting or disconnecting from battery. Wear protective clothing and use insulated tools.
- Keep all parts in good working condition and all hardware tightened. Replace all worn or damaged decals.
- Use only Toro approved attachments. Warranty may be voided if used with unapproved attachments.

# Slope Chart



# Safety and Instructional Decals



Safety decals and instructions are easily visible to the operator and are located near any area of potential danger. Replace any decal that is damaged or lost.



**1-403005**



**1**  
**58-6520**

1. Grease



**1-523552**



**66-1340**

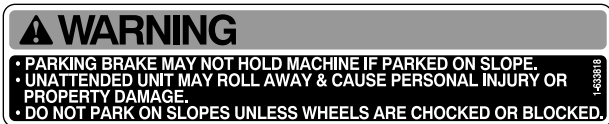

**1-633818**



**65-2690**



**54-9220**



**68-8340**



**98-4387**

1. Warning—wear hearing protection.

**⚠ DANGER**  
**COVER IS MISSING. DO NOT OPERATE THIS UNIT WHEN COVER IS NOT IN PLACE.**

**98-5954**

**⚠ WARNING**

- Hot exhaust components may ignite fuel or debris.
- Fire or explosion may occur, resulting in property damage, personal injury or death.
- Do not operate without entire exhaust system in place and in proper working condition.

**103-2644**

**SERVICE AID AND BELT ROUTING**

**Every 10 hours (daily):**  
 1. Check engine oil

**Every 50 hours:**  
 2. Check hydraulic oil  
 3. Check tire pressure—13 psi  
 4. Grease blade spindle bearings  
 5. Grease front wheel bearings  
 6. Grease deck lift linkage  
 7. Grease belt idler

**Every 250 hours:**  
 8. Grease brake linkage  
 9. Inspect belt and tension  
 10. Grease belt idler

**Every 1000 hours (yearly):**  
 11. Inspect covers and safety systems  
 12. Inspect fasteners and hoses  
 13. Grease front caster pivot

See operator's manual for additional details.

**107-1687**

**ANTI-SCALP ROLLER ADJUSTMENT**  
 FOR MAXIMUM DECK FLOTATION, PLACE ROLLERS IN POSITIONS SHOWN.  
 TURN ENGINE OFF BEFORE MAKING ROLLER ADJUSTMENTS.

- ————— 1.5"/38mm
- ————— 2.0"/51mm
- ————— 2.5"/63mm
- ————— 3.0"/76mm

**105-7798**

**- A**

- Short, light grass
- Dry conditions
- Maximum dispersion

**- B**

- Bagging setting

**- C**

- Tall, dense grass
- Wet conditions
- Maximum ground speed

• Césped corto y ligero  
 • Condiciones secas  
 • Maxima dispersion

• Posicion para usar con bolsa

• Césped alto y denso  
 • Condiciones mojadas  
 • Maxima velocidad

**107-1688**

**GREASE GRASA** →

**107-1613**



### Battery Symbols

Some or all of these symbols are on your battery

- |  |  |
|--|--|
| 1. Explosion hazard                    | 6. Keep bystanders a safe distance from the battery.                           |
| 2. No fire, open flame, or smoking.    | 7. Wear eye protection; explosive gases can cause blindness and other injuries |
| 3. Caustic liquid/chemical burn hazard | 8. Battery acid can cause blindness or severe burns.                           |
| 4. Wear eye protection                 | 9. Flush eyes immediately with water and get medical help fast.                |
| 5. Read the <i>Operator's Manual</i> . | 10. Contains lead; do not discard.   |

**⚠ WARNING**

- Operating on wet grass or steep slopes can cause sliding and loss of control.
- Wheels dropping over edges can cause rollovers, which may result in serious injury, death or drowning.
- To avoid loss of control and possibility of rollover:
  - Do NOT operate near drop-offs or near water.
  - Do NOT operate on slopes greater than 15°.
  - Reduce speed and use extreme caution on slopes.
  - Avoid sudden turns or rapid speed changes.
- There is no rollover protection when the roll bar is down.
- Always keep roll bar in the raised and locked position and use seat belt.
- Read and follow rollover protection instructions and warning.



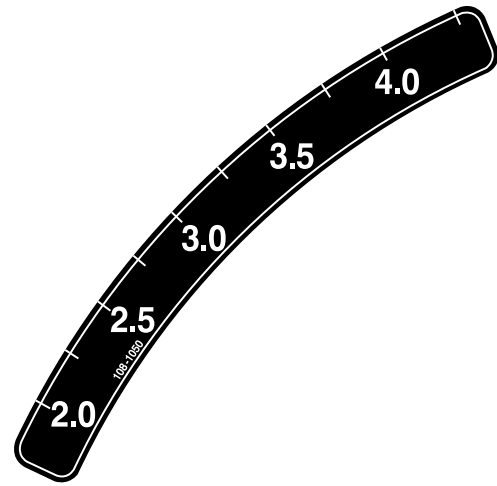

107-2112

**107-2112**

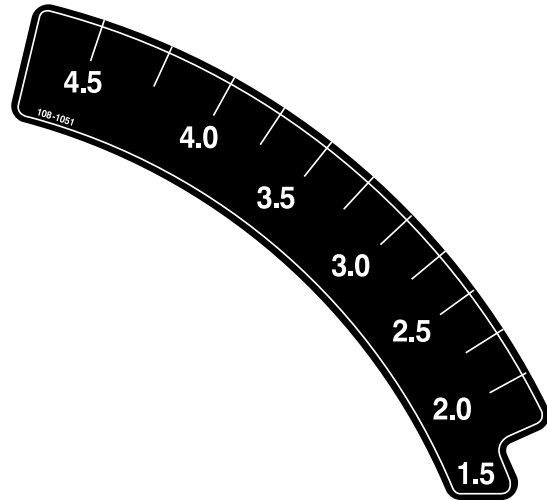

**108-1050**



**108-1051**

**⚠ WARNING**



**TO AVOID INJURY OR DEATH FROM ROLLOVER:**

Keep roll bar in the raised and locked position and use seat belt.



**THERE IS NO ROLL OVER PROTECTION WHEN THE ROLL BAR IS DOWN.**

Lower the roll bar only when absolutely necessary.

Do not wear seat belt when the roll bar is down.

Drive slowly and carefully.

Raise the roll bar as soon as clearance permits.

Read and follow slope operation instructions and warnings.

107-2102

**107-2102**

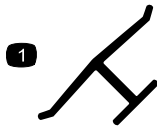

### Manufacturer's Mark

1. Indicates the blade is identified as a part from the original machine manufacturer.

**DISENGAGE**

↑

↓

**ENGAGE**

**(P)**

**BRAKE**

**⚠ WARNING**

To avoid serious injury or death:

- Read and understand the operator's manual before using this machine.
- Do not operate unless trained to safely use this machine.
- Do not operate under the influence of alcohol or drugs.
- Do not operate without shields, guards, and safety devices in place and working.
- Check the function of all safety interlocks daily.
- Do not defeat interlocks.
- Hearing protection is recommended.

**IMPORTANT!** Before starting engine, clean grass from pump compartment. Check more often in dry conditions.

For replacement manual, send model & serial number to: The Toro Co., 8111 Lyndale Ave. S., Bloomington, MN 55420.

**⚠ DANGER**

- Pick up objects that could be thrown by the blades.
- Never mow when bystanders are in the area.
- Never carry passengers.
- Look behind and to the side before changing directions.
- Stop the engine and remove key before adjusting, servicing or cleaning machine and attachments.

Before leaving the operator's position:

- Stop the engine and disengage the blade.
- Move the levers out to the neutral lock position.
- Set the parking brake.
- Avoid blades unless engine and blades are stopped.

**107-8445**

**⚠**

**+** **-**

**Pb**

**1**

**IMPORTANT !**

**BATTERY CHARGING INSTRUCTIONS**

Prior to first use of the battery, charge for a minimum of one hour at 6-10 amps.

**2**

107-9309

**107-9309**

1. Warning—read the *Operator's Manual* for information on charging the battery; contains lead; do not discard.
2. Read the *Operator's Manual*.

**MOTION CONTROL**

↑

↔

↓

**1**

**2**

**3**

**4**

**⚠ WARNING**

Battery contains sulfuric acid. Avoid contact and always shield eyes, face, skin and clothing from battery. Cigarettes, flames or sparks could cause battery to explode. Do not charge or use booster cables or adjust post connections without proper training. In event of an accident flush with water immediately. Keep out of reach of children.

**Drive Wheel Release**

Use 2-8 wrench. One turn counterclockwise to release. Do not over-tighten.

**MOTION CONTROL**

↑

↔

↓

**1**

**2**

**3**

**4**

**108-5995**

1. Fast
2. Slow
3. Neutral
4. Reverse



**110-0439**

- |                |                 |                                |                         |
|----------------|-----------------|--------------------------------|-------------------------|
| 1. Choke       | 3. Engine—run   | 5. Fast                        | 7. Slow                 |
| 2. Engine—stop | 4. Engine—start | 6. Continuous variable setting | 8. Power take-off (PTO) |
-

# Product Overview

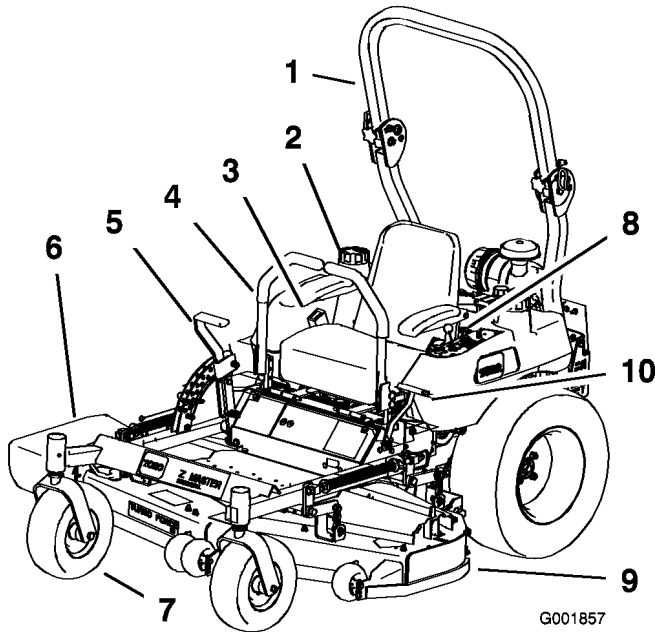
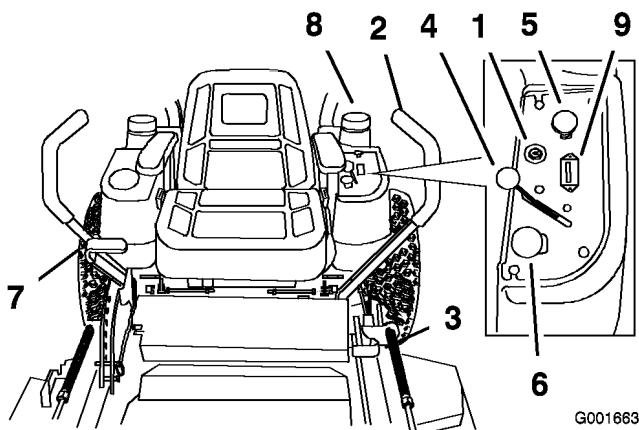

**Figure 3**

- |                          |                         |
|--------------------------|-------------------------|
| 1. Rollbar               | 6. Side discharge       |
| 2. Fuel cap (both sides) | 7. Front caster wheel   |
| 3. Seat belt             | 8. Controls             |
| 4. Motion control lever  | 9. Mower deck           |
| 5. Height-of-cut lever   | 10. Parking brake lever |

## Controls

Become familiar with all the controls before you start the engine and operate the machine (Figure 3 and Figure 4).

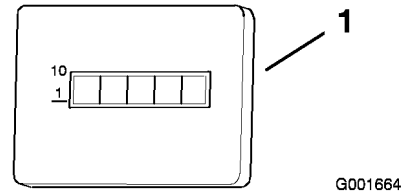

**Figure 4**

- |                             |                        |
|-----------------------------|------------------------|
| 1. Hour meter               | 6. Throttle control    |
| 2. Ignition switch          | 7. PTO Switch          |
| 3. Glow plug switch         | 8. Audible alarm       |
| 4. Glow plug light          | 9. Fuel selector valve |
| 5. Engine Temperature light |                        |

## Using the Hour Meter

The hour meter (Figure 5) records the number of hours the engine has operated. It operates when the engine is running. Use these times for scheduling regular maintenance.



**Figure 5**

1. Hour meter

## Using the Fuel Shutoff Valve

The machine has 2 fuel tanks, one on the left side and the other on the right side. Each tank connects to a check valve and then to a tee. From there a common fuel line leads to the engine (Figure 6).

Close the fuel shutoff valve before transporting or storing the machine.

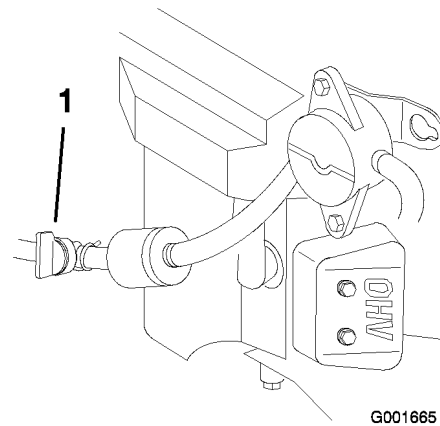

**Figure 6**

1. Fuel shutoff valve

# Operation

**Note:** Determine the left and right sides of the machine from the normal operating position.

## Adding Fuel

Use **Unleaded** Regular Gasoline suitable for automotive use (85 pump octane minimum). Leaded regular gasoline may be used if unleaded regular is not available.

**Important:** Never use methanol, gasoline containing methanol, or gasohol containing more than 10% ethanol because the fuel system could be damaged. Do not mix oil with gasoline.



In certain conditions, gasoline is extremely flammable and highly explosive. A fire or explosion from gasoline can burn you and others and can damage property.

- Fill the fuel tank outdoors, in an open area, when the engine is cold. Wipe up any gasoline that spills.
- Never fill the fuel tank inside an enclosed trailer.
- Do not fill the fuel tank completely full. Add gasoline to the fuel tank until the level is 1/4 to 1/2 inch (6 to 13 mm) below the bottom of the filler neck. This empty space in the tank allows gasoline to expand.
- Never smoke when handling gasoline, and stay away from an open flame or where gasoline fumes may be ignited by a spark.
- Store gasoline in an approved container and keep it out of the reach of children. Never buy more than a 30-day supply of gasoline.
- Do not operate without entire exhaust system in place and in proper working condition.



In certain conditions during fueling, static electricity can be released causing a spark which can ignite the gasoline vapors. A fire or explosion from gasoline can burn you and others and can damage property.

- Always place gasoline containers on the ground away from your vehicle before filling.
- Do not fill gasoline containers inside a vehicle or on a truck or trailer bed because interior carpets or plastic truck bed liners may insulate the container and slow the loss of any static charge.
- When practical, remove gas-powered equipment from the truck or trailer and refuel the equipment with its wheels on the ground.
- If this is not possible, then refuel such equipment on a truck or trailer from a portable container, rather than from a gasoline dispenser nozzle.
- If a gasoline dispenser nozzle must be used, keep the nozzle in contact with the rim of the fuel tank or container opening at all times until fueling is complete.



Gasoline is harmful or fatal if swallowed. Long-term exposure to vapors can cause serious injury and illness.

- Avoid prolonged breathing of vapors.
- Keep face away from nozzle and gas tank or conditioner opening.
- Keep gas away from eyes and skin.

## Using Stabilizer/Conditioner

Use a fuel stabilizer/conditioner in the machine to provide the following benefits:

- Keeps gasoline fresh during storage of 90 days or less. For longer storage it is recommended that the fuel tank be drained.

- Cleans the engine while it runs
- Eliminates gum-like varnish buildup in the fuel system, which causes hard starting

**Important:** Do not use fuel additives containing methanol or ethanol.

Add the correct amount of gas stabilizer/conditioner to the gas.

**Note:** A fuel stabilizer/conditioner is most effective when mixed with fresh gasoline. To minimize the chance of varnish deposits in the fuel system, use fuel stabilizer at all times.

### Filling the Fuel Tank

1. Shut the engine off and set the parking brake.
2. Clean around each fuel tank cap and remove the cap.
3. Add unleaded regular gasoline to both fuel tanks, until the level is 1/4 to 1/2 inch (6 mm to 13 mm) below the bottom of the filler neck.

This space in the tank allows gasoline to expand. Do not fill the fuel tanks completely full.

4. Install fuel tank caps securely.
5. Wipe up any gasoline that may have spilled.

### Checking the Engine Oil Level

Before you start the engine and use the machine, check the oil level in the engine crankcase; refer to Checking Oil Level in Engine Maintenance, page 29

### Using the Rollover Protection System (ROPS)



To avoid injury or death from rollover: keep the roll bar in the raised locked position and use the seat belt.

Ensure that the rear part of the seat is secured with the seat latch.



**There is no rollover protection when the roll bar is in the down position.**

- Lower the roll bar only when absolutely necessary.
- Do not wear the seat belt when the roll bar is in the down position.
- Drive slowly and carefully.
- Raise the roll bar as soon as clearance permits.
- Check carefully for overhead clearances (i.e. branches, doorways, electrical wires) before driving under any objects and do not contact them.

**Important:** Lower the roll bar only when absolutely necessary.

1. To lower the roll bar, loosen the front knobs (Figure 9).
2. Remove the hairpin cotter pins and remove the two pins (Figure 8).
3. Lower the roll bar to the down position. There are two down positions. See Figure 7 for the positions.
4. Install the two pins and secure them with the hairpin cotter pins (Figure 8).

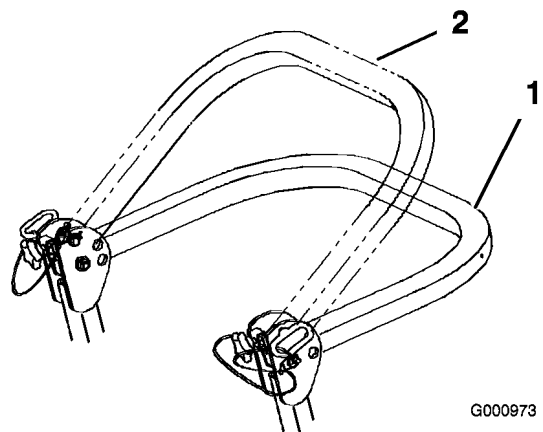

**Figure 7**

1. Full down position
2. Down position with bagger installed

**Important:** Ensure that the rear part of the seat is secured with the seat latch.

5. To raise the roll bar, remove the hairpin cotter pins and remove the two pins (Figure 8).
6. Raise the roll bar to the upright position and install the two pins and secure them with the hairpin cotter pins (Figure 8).

**Important:** Always use the seat belt with the roll bar in the raised position.

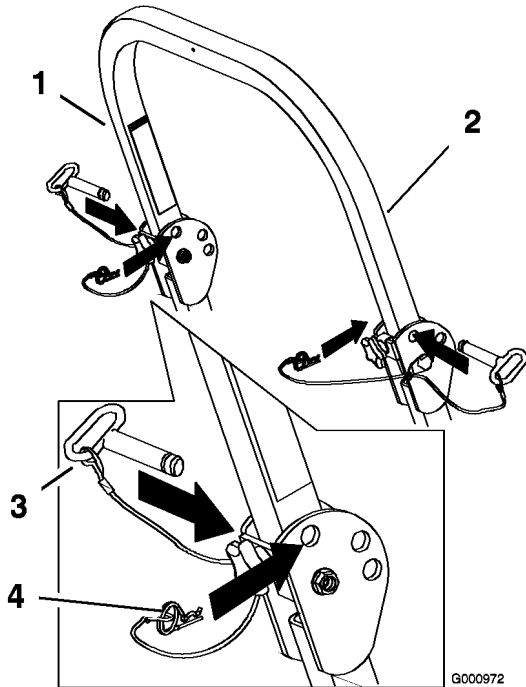

**Figure 8**

- |                    |                       |
|--------------------|-----------------------|
| 1. Roll bar        | 3. Pin                |
| 2. Raised position | 4. Hairpin cotter pin |

**Important:** Tighten the front knobs against the center roll bar ends (Figure 9).

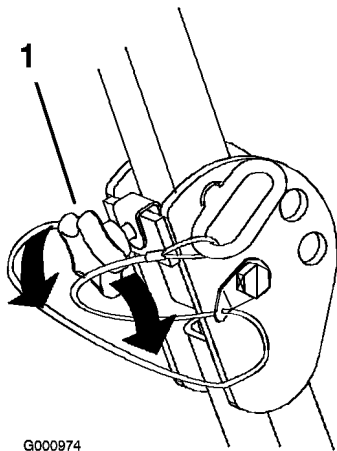

**Figure 9**

1. Front handle

## Think Safety First

Please read all safety instructions and symbols in the safety section. Knowing this information could help you or bystanders avoid injury.



Operating on wet grass or steep slopes can cause sliding and loss of control.

Wheels dropping over edges can cause rollovers, which may result in serious injury, death or drowning.

There is no rollover protection when the roll bar is down.

Always keep the roll bar in the raised and locked position and use the seat belt.

Read and follow the rollover protection instructions and warnings.

To avoid loss of control and possibility of rollover:

- Do not operate near drop-offs or near water.
- Do not operate on slopes greater than 15 degrees.
- Reduce speed and use extreme caution on slopes.
- Avoid sudden turns or rapid speed changes.

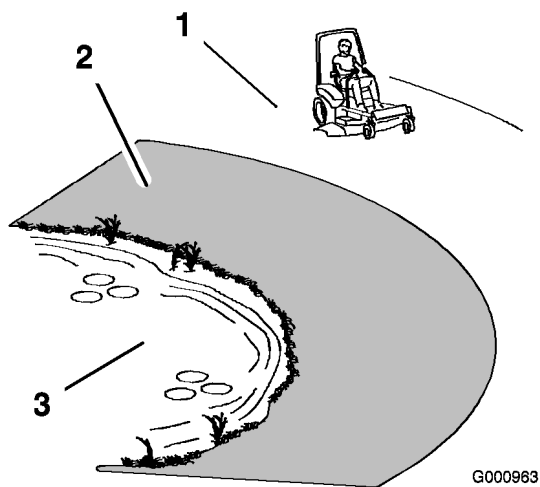

**Figure 10**

1. Safe Zone-use the Z Master here on slopes less than 15 degrees or flat areas.
2. Use walk behind mower and/or hand trimmer near drop-offs and water.
3. Water

**This machine produces sound levels in excess of 85 dBA at the operators ear and can cause hearing loss through extended periods of exposure.**

**Wear hearing protection when operating this machine.**

The use of protective equipment for eyes, ears, feet and head is recommended.

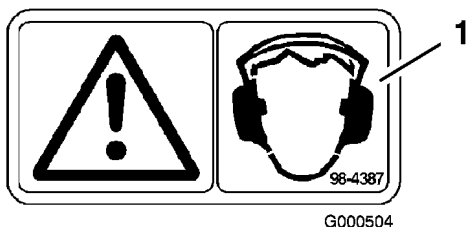

**Figure 11**

1. Warning— wear hearing protection

## Operating the Parking Brake

Always set the parking brake when you stop the machine or leave it unattended.

## Setting the Parking Brake

1. Move the motion control levers (Figure 18) out to the neutral lock position.
2. Pull up and back on the parking brake lever to set the parking brake (Figure 12). The parking brake lever should stay firmly in the engaged position.

**Parking brake may not hold machine parked on a slope and could cause personal injury or property damage.**

**Do not park on slopes unless wheels are chocked or blocked**

## Releasing the Parking Brake

Push forward and down on the parking brake lever to release the parking brake (Figure 12).

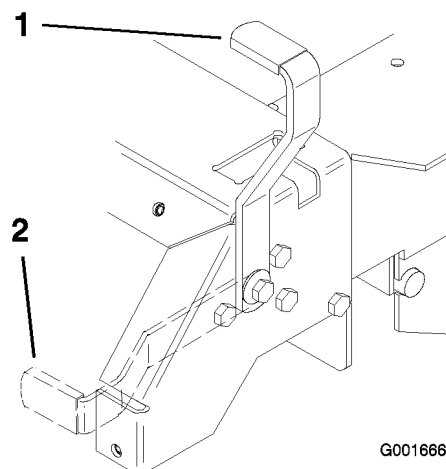

**Figure 12**

1. Parking brake-ON
2. Parking brake-OFF
3. Brake Stop

## Starting and Stopping the Engine

### Starting the Engine

1. Sit on the seat and move the motion controls to neutral locked position.
2. Set the parking brake; refer to Setting the Parking Brake.
3. Move the PTO (power take off) switch to the Off position (Figure 13).

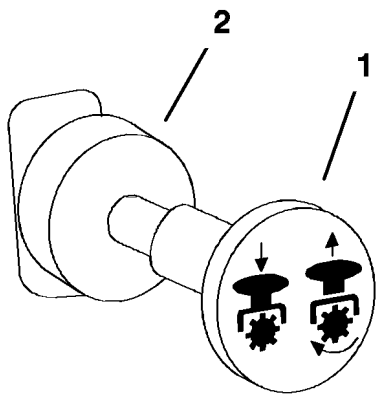

G000937

**Figure 13**

1. PTO—on
2. PTO—off

4. Move the choke control to the **on** position before starting a cold engine (Figure 14).

**Note:** A warm or hot engine may not require choking. After engine starts, move choke control to Run position.

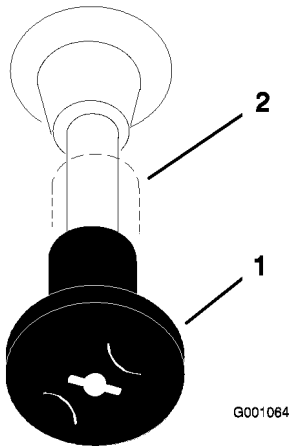

G001064

**Figure 14**

1. Choke—on
2. Choke—off

5. Move the throttle control to the Fast position before starting a cold engine (Figure 15).

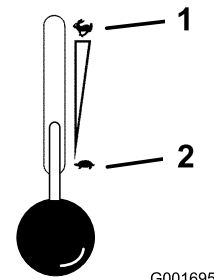

G001695

**Figure 15**

1. Throttle—fast
2. Throttle—slow

6. Turn the ignition key to Start. When the engine starts, release the key (Figure 16).

**Important:** Do not engage starter for more than 10 seconds at a time. If engine fails to start allow 30 second cool-down period between attempts. Failure to follow these instructions can burn out starter motor.

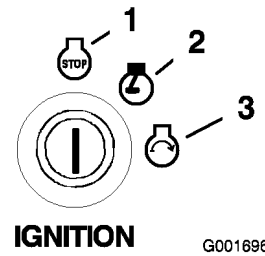

IGNITION

G001696

**Figure 16**

1. Off
2. Run
3. Start

7. After the engine starts, move the choke to off (Figure 14). If the engine stalls or hesitates, move the choke back to on for a few seconds, then move the throttle lever to desired setting. Repeat this as required.

## Stopping the Engine

1. Push the PTO to the off position (Figure 13).
2. Move the throttle lever midway between the slow and fast positions (Figure 15).
3. Let the engine idle for 60 seconds.
4. Turn the ignition key to the off position and remove the key (Figure 16).
5. Close the fuel shut off valve before transporting or storing the machine.

**Important:** Make sure that the fuel shut off valve is closed before transporting or storing the machine, as fuel leakage may occur. Set the parking brake before transporting. Make sure to remove the key as the fuel pump may run and cause the battery to lose charge.



Children or bystanders may be injured if they move or attempt to operate the tractor while it is unattended.

Always remove the ignition key and set the parking brake when leaving the machine unattended, even if just for a few minutes.

## Operating the Power Take Off (PTO)

The power take off (PTO) switch starts and stops the mower blades and any powered attachments.

### Engaging the PTO

1. If the engine is cold, allow the engine to warm up 5 to 10 minutes before engaging the PTO.
2. While seated in the seat, release the pressure on the traction control levers and place in neutral.
3. Place the throttle in the fast position.

**Note:** Engaging the PTO with the throttle at the half or less position will cause excessive wear to the drive belts.

4. Pull out on the power take off (PTO) switch to engage it (Figure 17).

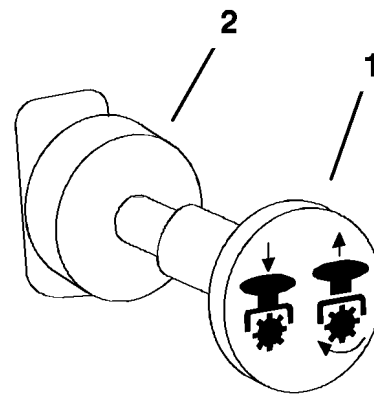

G000937

**Figure 17**

1. PTO-On

2. PTO-Off

### Disengaging the PTO

To disengage, push the PTO switch to the off position (Figure 17).

## The Safety Interlock System



If safety interlock switches are disconnected or damaged the machine could operate unexpectedly causing personal injury.

- Do not tamper with the interlock switches.
- Check the operation of the interlock switches daily and replace any damaged switches before operating the machine.

### Understanding the Safety Interlock System

The safety interlock system is designed to prevent the engine from starting unless:

- You are sitting on the seat.
- The parking brake is engaged.
- The power take off (PTO) is disengaged.
- The motion control levers are in the neutral locked position

The safety interlock system also is designed to stop the engine when the traction controls are moved from the locked position with the parking brake

engaged or if you rise from the seat when the PTO is engaged.

## Testing the Safety Interlock System

Test the safety interlock system before you use the machine each time. If the safety system does not operate as described below, have an Authorized Service Dealer repair the safety system immediately.

1. Sitting on the seat, engage the parking brake and move the PTO to on. Try starting the engine; the engine should not crank.
2. Sitting on the seat, engage the parking brake and move the PTO to off. Move either motion control lever (out of neutral locked position). Try starting the engine; the engine should not crank. Repeat for other control lever.
3. Sitting on the seat, engage the parking brake, move the PTO switch to off and move the motion control levers to neutral lock position. Now start the engine. While the engine is running, release the parking brake, engage the PTO and rise slightly from the seat; the engine should stop.
4. Sitting on the seat, engage the parking brake, move the PTO switch to off and move the motion control levers to neutral lock position. Now start the engine. While the engine is running, center either motion control and move (forward or reverse); the engine should stop. Repeat for other motion control.
5. Sitting on the seat, disengage the parking brake, move the PTO switch to off and move the motion control levers to neutral lock position. Try starting the engine; the engine should not crank.

## Driving Forward or Backward

The throttle control regulates the engine speed as measured in RPM (revolutions per minute). Place the throttle control in the fast position for best performance. Always operate in the full throttle position when mowing.



**Machine can spin very rapidly. Operator may lose control of machine and cause personal injury or damage to machine.**

- Use caution when making turns.
- Slow the machine down before making sharp turns.

## Driving Forward

1. Release the parking brake; refer to Releasing the Parking Brake in Operation, page 14.
2. Move the levers to the center, un-locked position.
3. To go forward, slowly push the motion control levers forward (Figure 18).

**Note:** The engine will kill if the traction control levers are moved with the parking brake engaged.

To go straight, apply equal pressure to both motion control levers (Figure 18).

To turn, move the motion control lever toward neutral in the direction you want to turn (Figure 18).

The farther you move the traction control levers in either direction, the faster the machine will move in that direction.

To stop, pull the motion control levers to the neutral position.

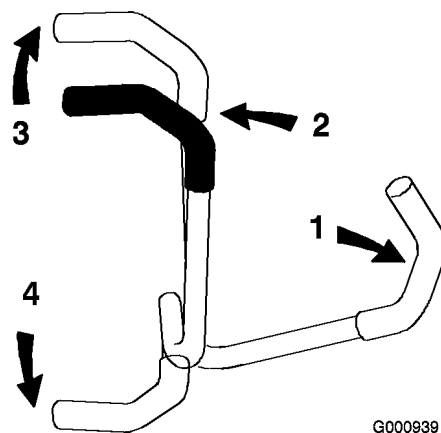

G000939

**Figure 18**

- |   |             |
|---|-------------|
| 1. Motion control lever-neutral lock position | 3. Forward  |
| 2. Center un-lock position                    | 4. Backward |

## Driving Backward

1. Move the levers to the center, un-locked position.
2. To go backward, slowly pull the motion control levers rearward (Figure 18).

To go straight, apply equal pressure to both motion control levers (Figure 18).

To turn, release pressure on the motion control lever toward the direction you want to turn (Figure 18).

To stop, push the motion control levers to the neutral position.

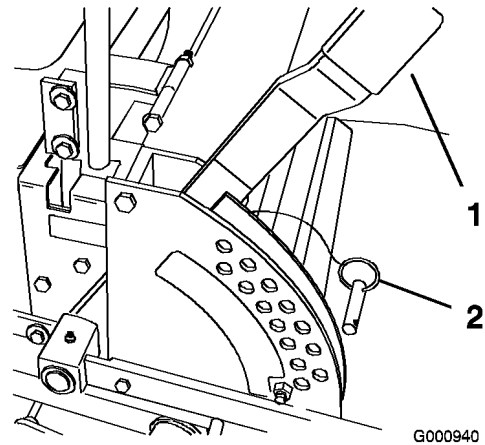

**Figure 19**

1. Height of cut lever
2. Clevis Pin

## Stopping the Machine

To stop the machine, move the traction control levers to neutral and move to locked position, disengage the power take off (PTO), and turn the ignition key to off.

Set the parking brake when you leave the machine; refer to Setting the Parking Brake in Operation, page 14. Remember to remove the key from the ignition switch.



**Children or bystanders may be injured if they move or attempt to operate the tractor while it is unattended.**

**Always remove the ignition key and set the parking brake when leaving the machine unattended, even if just for a few minutes.**

## Adjusting the Height-of-Cut

The height-of-cut is adjusted from 1-1/2 to 4-1/2 inch (38 to 114 mm) in 1/4 inch (6 mm) increments by relocating the clevis pin into different hole locations.

1. Raise the height-of-cut lever to the transport position (also the 4-1/2 inch (114 mm) cutting height position) (Figure 19).
2. To adjust, remove the clevis pin from the height-of-cut bracket (Figure 19).
3. Select a hole in the height-of-cut bracket corresponding to the height-of-cut desired and, insert the clevis pin (Figure 19).
4. Move the lever to the selected height.

## Adjusting the Anti-Scalp Rollers

Whenever you change the height-of-cut, it is recommended to adjust the height of the anti-scalp rollers.

1. Disengage the PTO, move the motion control levers to the neutral locked position and set the parking brake.
2. Stop the engine, remove the key, and wait for all moving parts to stop before leaving the operating position.
3. After adjusting the height-of-cut, adjust the rollers by removing the flange nut, bushing, spacer, and bolt (Figure 20 , Figure 21 and Figure 50 ).

**Note:** The two middle rollers will not have a spacer (Figure 21).

4. Select a hole so the anti-scalp roller is positioned to the nearest corresponding height-of-cut desired.
5. Install the flange nut bushing, spacer, and bolt. Torque to 40-45 ft-lb (54-61 N•m) (Figure 20 , Figure 21 and Figure 50 ).
6. Repeat this adjustment on the other anti-scalp rollers.

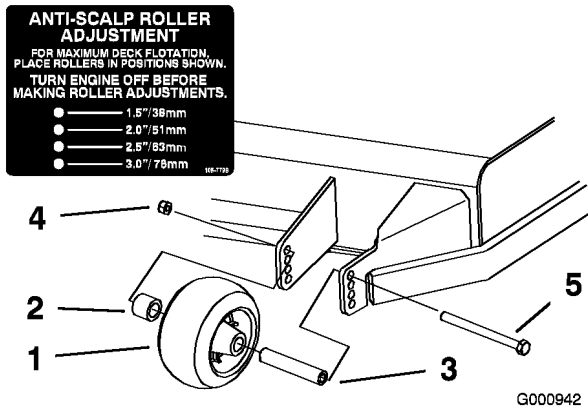

**Figure 20**

- |                      |               |
|----------------------|---------------|
| 1. Anti-scalp roller | 4. Flange Nut |
| 2. Spacer            | 5. Bolt       |
| 3. Bushing           |               |

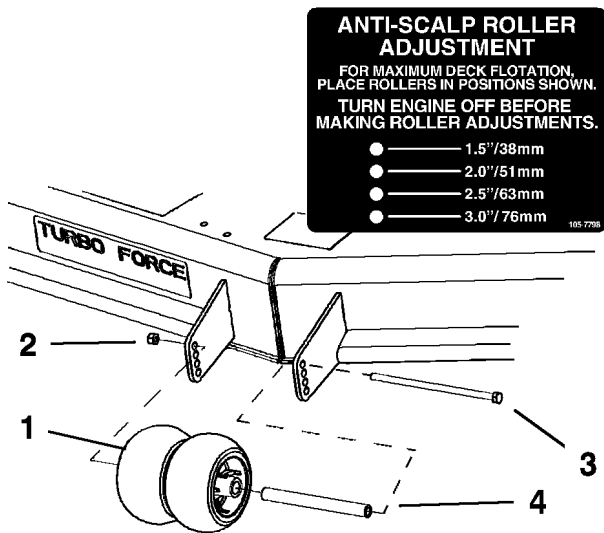

**Figure 21**

- |                      |               |
|----------------------|---------------|
| 1. Anti-scalp roller | 3. Flange Nut |
| 2. Bushing           | 4. Bolt       |

## Adjusting the Flow Baffle

The mower discharge flow can be adjusted for different types of mowing conditions. Position the cam lock and baffle to give the best quality of cut.

1. Disengage the PTO, move the motion control levers to the neutral locked position and set the parking brake.
2. Stop the engine, remove the key, and wait for all moving parts to stop before leaving the operating position.
3. To adjust the cam lock, swing the lever up to loosen the cam lock (Figure 22).

4. Adjust the baffle and cam lock in the slot to the desired discharge flow.
5. Swing the lever back over to tighten the baffle and cam lock (Figure 22).
6. If the cam does not lock the baffle into place or it is too tight, loosen the lever and then rotate the cam lock. Adjust the cam lock until the desired locking pressure is achieved.

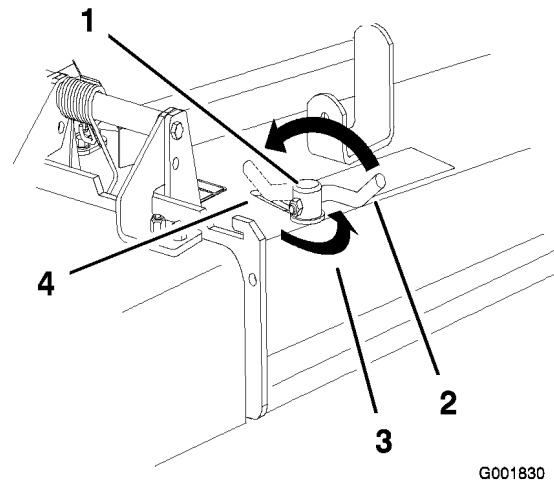

**Figure 22**

- |             |  |
|-------------|--|
| 1. Cam lock | 3. Rotate cam to increase or decrease locking pressure |
| 2. Lever    | 4. Slot  |

## Positioning the Flow Baffle

The following figures are only recommendations for use. Adjustments will vary by grass type, moisture content, and height of grass.

**Note:** If the engine power draws down and the mower ground speed is the same, open up the baffle.

### Position A

This is the full rear position. The suggested use for this position is as follows.

- Use for short, light grass mowing conditions.
- Use in dry conditions.
- For smaller grass clippings.
- Propels grass clippings farther away from the mower.

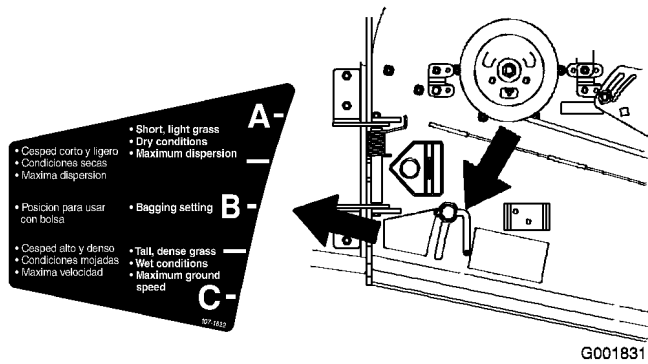

**Figure 23**

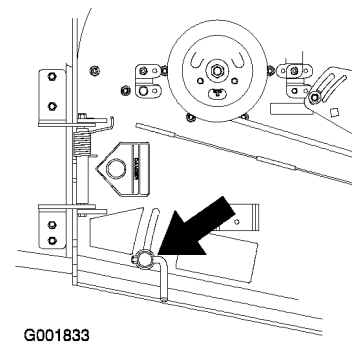

**Figure 25**

## Position B

Use this position when bagging.

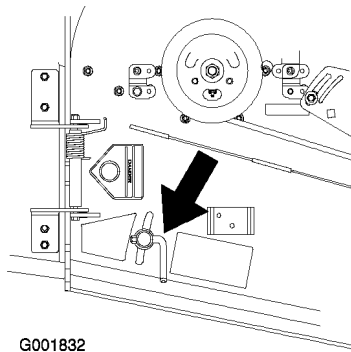

**Figure 24**

## Position C

This is the full open position. The suggested use for this position is as follows.

- Use in tall, dense grass mowing conditions.
- Use in wet conditions.
- Lowers the engine power consumption.
- Allows increased ground speed in heavy conditions.
- This position is similar to the benefits of the Toro SFS mower.

## Positioning the Seat

The seat can move forward and backward. Position the seat where you have the best control of the machine and are most comfortable.

**Important:** To adjust, move the lever sideways to unlock seat (Figure 26).

Slide the seat to the desired position and release lever to lock in position.

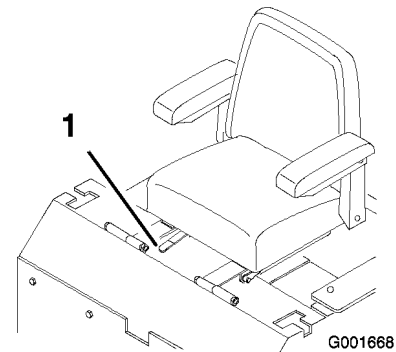
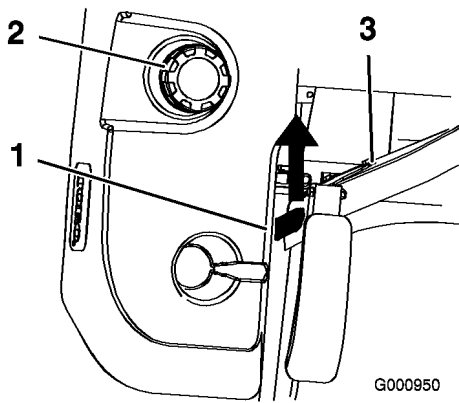

**Figure 26**

1. Adjustment lever

## Unlatching the Seat

Push the seat latch rearward to unlatch the seat. This will allow access to the machine under the seat (Figure 27).



**Figure 27**

1. Seat latch
2. Fuel cap
3. Seat

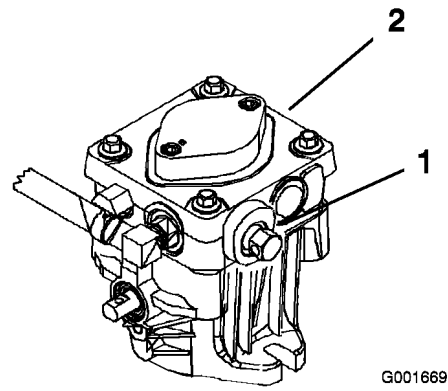

**Figure 28**

1. Side console controls
2. By-pass valve
3. Hydraulic pumps

## Pushing the Machine by Hand

**Important:** Always push the machine by hand. Never tow the machine because hydraulic damage may occur.

### Pushing the Machine

1. Disengage the power take off (PTO) and turn the ignition key to off. Move the levers to neutral locked position and apply parking brake. Remove the key.
2. Rotate the by-pass valves counterclockwise 1 turn to push. This allows hydraulic fluid to by-pass the pump enabling the wheels to turn (Figure 28).  
**Important:** Do not rotate by-pass valves more than 1 turn. This prevents valves from coming out of the body and causing fluid to run out.
3. Disengage parking brake before pushing.

### Changing to Machine Operation

Rotate the by-pass valves clockwise 1 turn to operate machine (Figure 28).

**Note:** Do not over tighten the by-pass valves.

The machine will not drive unless by-pass valves are turned in.

## Using the Side Discharge

The mower has a hinged grass deflector that disperses clippings to the side and down toward the turf.



Without the grass deflector, discharge cover, or complete grass catcher assembly mounted in place, you and others are exposed to blade contact and thrown debris. Contact with rotating mower blade(s) and thrown debris will cause injury or death.

- Never remove the grass deflector from the mower because the grass deflector routes material down toward the turf. If the grass deflector is ever damaged, replace it immediately.
- Never put your hands or feet under the mower.
- Never try to clear the discharge area or mower blades unless you move the power take off (PTO) to the off position, rotate the ignition key to off and remove the key.
- Make sure the grass deflector is in the down position.

## Transporting Machines

Use a heavy-duty trailer or truck to transport the machine. Ensure that the trailer or truck has all necessary lighting and marking as required by law.

Please carefully read all the safety instructions. Knowing this information could help you, your family, pets or bystanders avoid injury.

To transport the machine:

- Lock the brake and block the wheels.
- Securely fasten the machine to the trailer or truck with straps, chains, cable, or ropes.
- Secure a trailer to the towing vehicle with safety chains.



**Driving on the street or roadway without turn signals, lights, reflective markings, or a slow moving vehicle emblem is dangerous and can lead to accidents causing personal injury.**

**Do not drive machine on a public street or roadway.**

## Loading Machines

Use extreme caution when loading units on trailers or trucks. One full width ramp that is wide enough to extend beyond the rear tires is recommended instead of individual ramps for each side of the unit (Figure 29). The lower rear section of the tractor frame extends back between the rear wheels and serves as a stop for tipping backward. Having a full width ramp provides a surface for the frame members to contact if the unit starts to tip backward. If it is not possible to use one full width ramp, use enough individual ramps to simulate a full width continuous ramp.

The ramp should be long enough so that the angles do not exceed 15 degrees (Figure 29). A steeper angle may cause mower components to get caught as the unit moves from ramp to trailer or truck. Steeper angles may also cause the unit to tip backward. If loading on or near a slope, position the trailer or truck so it is on the down side of the slope and the ramp extends up the slope. This will minimize the ramp angle. The trailer or truck should be as level as possible.

**Important: Do Not attempt to turn the unit while on the ramp; you may lose control and drive off the side.**

Avoid sudden acceleration when driving up a ramp and sudden deceleration when backing down a

ramp. Both maneuvers can cause the unit to tip backward.



**Loading a unit onto a trailer or truck increases the possibility of backward tip-over and could cause serious injury or death.**

- Use extreme caution when operating a unit on a ramp.
- Use only a single, full width ramp; Do Not use individual ramps for each side of the unit.
- If individual ramps must be used, use enough ramps to create an unbroken ramp surface wider than the unit.
- Do not exceed a 15 degree angle between ramp and ground or between ramp and trailer or truck.
- Avoid sudden acceleration while driving unit up a ramp to avoid tipping backward.
- Avoid sudden deceleration while backing unit down a ramp to avoid tipping backward.

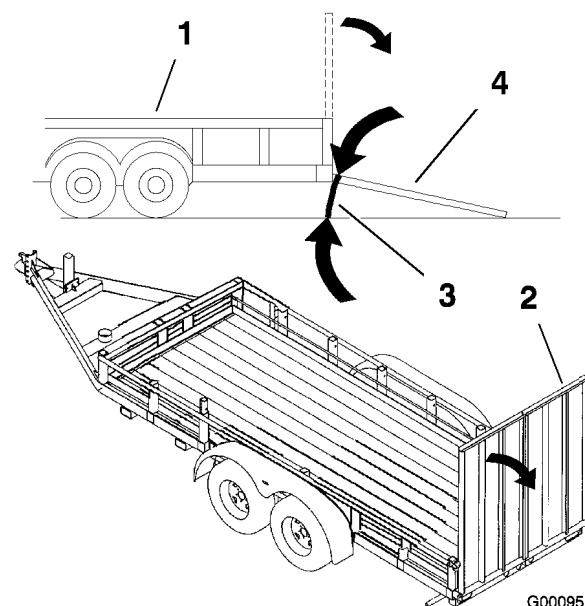

**Figure 29**

- |                    |                                |
|--------------------|--------------------------------|
| 1. Trailer         | 3. Not greater than 15 degrees |
| 2. Full width ramp | 4. Full width ramp—side view   |

## **Operating Tips**

### **Fast Throttle Setting**

For best mowing and maximum air circulation, operate the engine at the fast throttle position. Air is required to thoroughly cut grass clippings, so do not set the height-of-cut so low as to totally surround the mower by uncut grass. Always try to have one side of the mower free from uncut grass, which allows air to be drawn into the mower.

### **Cutting a Lawn for the First Time**

Cut grass slightly longer than normal to ensure the cutting height of the mower does not scalp any uneven ground. However, the cutting height used in the past is generally the best one to use. When cutting grass longer than six inches tall, you may want to cut the lawn twice to ensure an acceptable quality of cut.

### **Cut 1/3 of the Grass Blade**

It is best to cut only about 1/3 of the grass blade. Cutting more than that is not recommended unless grass is sparse, or it is late fall when grass grows more slowly.

### **Mowing Direction**

Alternate mowing direction to keep the grass standing straight. This also helps disperse clippings which enhances decomposition and fertilization.

### **Mow at Correct Intervals**

Normally, mow every four days. But remember, grass grows at different rates at different times. So to maintain the same cutting height, which is a good practice, mow more often in early spring. As the grass growth rate slows in mid summer, mow less frequently. If you cannot mow for an extended period, first mow at a high cutting height; then mow again two days later at a lower height setting.

### **Cutting Speed**

To improve cut quality, use a slower ground speed in certain conditions.

### **Avoid Cutting Too Low**

If the cutting width of the mower is wider than the mower you previously used, raise the cutting height to ensure that uneven turf is not cut too short.

## **Long Grass**

If the grass is ever allowed to grow slightly longer than normal, or if it contains a high degree of moisture, raise the cutting height higher than usual and cut the grass at this setting. Then cut the grass again using the lower, normal setting.

## **When Stopping**

If the machine's forward motion must be stopped while mowing, a clump of grass clippings may drop onto your lawn. To avoid this, move onto a previously cut area with the blades engaged.

## **Keep the Underside of the Mower Clean**

Clean clippings and dirt from the underside of the mower after each use. If grass and dirt build up inside the mower, cutting quality will eventually become unsatisfactory.

## **Blade Maintenance**

Maintain a sharp blade throughout the cutting season because a sharp blade cuts cleanly without tearing or shredding the grass blades. Tearing and shredding turns grass brown at the edges, which slows growth and increases the chance of disease. Check the cutter blades daily for sharpness, and for any wear or damage. File down any nicks and sharpen the blades as necessary. If a blade is damaged or worn, replace it immediately with a genuine Toro replacement blade.

# Maintenance

## Recommended Maintenance Schedule(s)

Maintenance Service Interval	Maintenance Procedure
After the first 8 operating hours	<ul style="list-style-type: none"> <li>• Change the engine oil.</li> <li>• Check the hydraulic fluid.</li> <li>• Change the hydraulic filter and oil.</li> </ul>
Before each use or daily	<ul style="list-style-type: none"> <li>• Check the safety system.</li> <li>• Check the engine oil level.</li> <li>• Clean the air intake screen.</li> <li>• Check the mower blades.</li> <li>• Clean the mower deck.</li> </ul>
Every 25 hours	<ul style="list-style-type: none"> <li>• Grease the mower deck and spindles.</li> <li>• Grease the mower belt idler arm.</li> <li>• Grease the pump belt idler arm.</li> <li>• Grease the drive belt idler arm.</li> <li>• Check the hydraulic fluid.</li> </ul>
Every 50 hours	<ul style="list-style-type: none"> <li>• Check the tire pressure.</li> <li>• Check pump drive belt.</li> </ul>
Every 100 hours	<ul style="list-style-type: none"> <li>• Change the engine oil.</li> <li>• Check the spark plugs.</li> <li>• Check and clean engine cooling fins and shrouds.</li> <li>• Inspect the belts for cracks and wear.</li> <li>• Check the hydraulic hoses.</li> </ul>
Every 150 hours	<ul style="list-style-type: none"> <li>• Lubricate the machine with light oil (Refer to Lubrication).</li> </ul>
Every 200 hours	<ul style="list-style-type: none"> <li>• Check and/or replace the primary air filter.</li> <li>• Replace the oil filter.</li> <li>• Replace the fuel filter.</li> <li>• Change the hydraulic filter and oil.</li> </ul>
Every 500 hours	<ul style="list-style-type: none"> <li>• Check the wheel hub slotted nut.</li> <li>• Adjust the caster pivot bearing.</li> </ul>
Every 600 hours	<ul style="list-style-type: none"> <li>• Replace the safety filter.</li> </ul>
Yearly	<ul style="list-style-type: none"> <li>• Grease the front caster pivots (more often in dirty or dusty conditions).</li> </ul>

**Important:** Refer to your engine operator's manual for additional maintenance procedures.



If you leave the key in the ignition switch, someone could accidentally start the engine and seriously injure you or other bystanders.

Remove the key from the ignition and disconnect the wire from the spark plug(s) before you do any maintenance. Set the wire aside so that it does not accidentally contact the spark plug.

# Lubrication

## Greasing and Lubrication

Lubricate the machine when shown on the Check Service Reference Aid decal (Figure 30). Grease more frequently when operating conditions are extremely dusty or sandy.

Grease Type: General-purpose grease.

### How to Grease

1. Disengage the PTO, move the motion control levers to the neutral locked position and set the parking brake.
2. Stop the engine, remove the key, and wait for all moving parts to stop before leaving the operating position.
3. Clean the grease fittings with a rag. Make sure to scrape any paint off the front of the fitting(s).
4. Connect a grease gun to the fitting. Pump grease into the fittings until grease begins to ooze out of the bearings.
5. Wipe up any excess grease.

### Greasing the Front Caster Pivots

Lubricate the front caster pivots once a year.

1. Remove the dust cap and adjust the caster pivots. Keep the dust cap off until greasing is done. Refer to Adjusting the Caster Pivot Bearing in Drive System Maintenance, page 36.
2. Remove the hex plug. Thread a grease zerk into the hole.
3. Pump grease into the zerk until it oozes out around the top bearing.
4. Remove the grease zerk in the hole. Install the hex plug and cap.

### Where to Add Grease

Lubricate the grease fittings as shown on the Check Service Reference Aid decal (Figure 30).

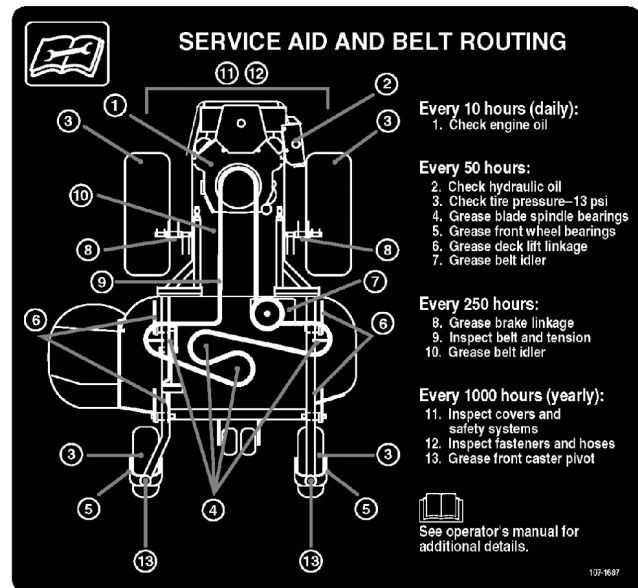

G001671

Figure 30

### Where to Add Light Oil or Spray Lubrication

Lubricate the machine in the following areas with spray type lubricant or light oil. Lubricate every 150 hours.

- Seat switch actuator.
- Brake handle pivot.
- Brake rod bushings.
- Motion control bronze bushings.

### Greasing the Mower Deck and Belt Idlers

The mower deck must be lubricated weekly or every 25 hours. Grease with No. 2 general purpose lithium base or molybdenum base grease.

**Important: Make sure cutting unit spindles are full of grease weekly.**

1. Disengage the PTO, move the motion control levers to the neutral locked position and set the parking brake.
2. Stop the engine, remove the key, and wait for all moving parts to stop before leaving the operating position.
3. Remove the belt covers.

- Grease the three spindle bearings under the pulleys until grease comes out the lower seals (Figure 31).
- Grease the idler arm on the mower deck (Figure 31).
- Grease the fittings on the push arms (Figure 31).

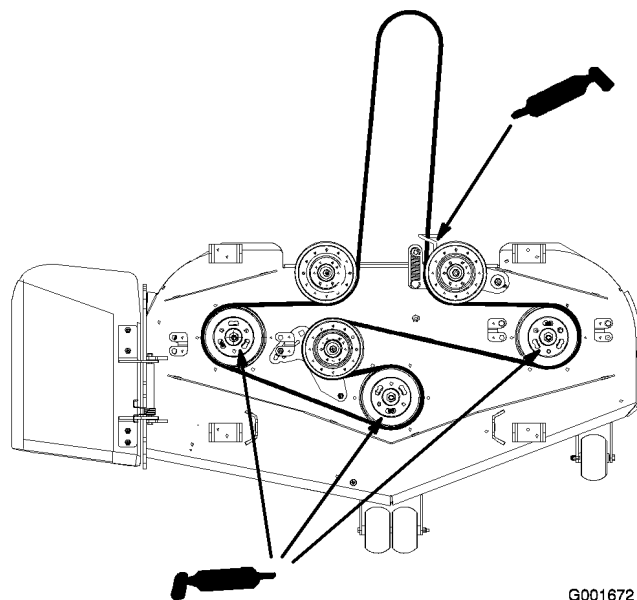

**Figure 31**

## Engine Maintenance

### Servicing the Air Cleaner

**Primary Filter:** Check and/or replace it after every 200 operating hours or more often in dusty conditions.

**Safety Filter:** Replace it after every 600 operating hours.

**Note:** Check the filters more frequently if the operating conditions are extremely dusty or sandy.

#### Removing the Filters

- Disengage the PTO, move the motion control levers to the neutral locked position, and set the parking brake.
- Stop the engine, remove the key, and wait for all moving parts to stop before leaving the operating position.

- Release the latches on the air cleaner and pull the air cleaner cover off the air cleaner body (Figure 32).

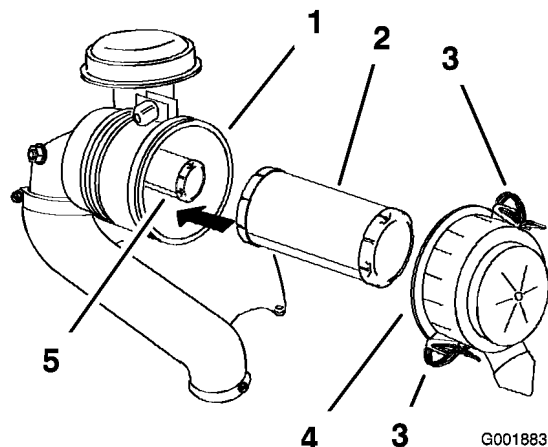

**Figure 32**

- |                     |                      |
|---------------------|----------------------|
| 1. Air cleaner body | 4. Air cleaner cover |
| 2. Primary filter   | 5. Safety filter     |
| 3. Latch            |                      |

- Clean the inside of the air cleaner cover with compressed air.
- Gently slide the primary filter out of the air cleaner body (Figure 32).

**Note:** Avoid knocking the filter into the side of the body.

- Remove the safety filter only if you intend to replace it.

**Important:** Never attempt to clean the safety filter. If the safety filter is dirty, then the primary filter is damaged. Replace both filters.

- Inspect the primary filter for damage by looking into the filter while shining a bright light on the outside of the filter. Holes in the filter will appear as bright spots. If the filter is damaged, discard it.

#### Servicing the Primary Filter

- Check and/or replace the primary filter after 200 operating hours.
- If the primary filter is dirty, bent, or damaged, replace it.
- Do not clean the primary filter.

#### Servicing the Safety Filter

Replace the safety filter after 600 operating hours.

**Important:** Never attempt to clean the safety filter. If the safety filter is dirty, then the primary filter is damaged. Replace both filters.

## Installing the Filters

**Important:** To prevent engine damage, always operate the engine with both air filters and cover installed.

1. If installing new filters, check each filter for shipping damage. Do not use a damaged filter.
2. If the safety filter is being replaced, carefully slide it into the filter body (Figure 32).
3. Carefully slide the primary filter over the safety filter (Figure 32).

**Note:** Ensure that the primary filter is fully seated by pushing on its outer rim while installing it.

**Important:** Do not press on the soft inside area of the filter.

4. Install the air cleaner cover with the side indicated as **up** facing upward and secure the latches (Figure 32).

## Servicing the Engine Oil

### Service Interval/Specification

Change the engine oil as follows:

- After the first 8 operating hours
- After every 100 operating hours

**Note:** Change the oil more frequently when the operating conditions are extremely dusty or sandy.

Oil Type: Detergent oil (API service SF, SG, SH, or SJ)

Crankcase Capacity: 58 ounces (1.7 liter) with the filter removed; 51 ounces (1.5 liter) without the filter removed

Viscosity: Refer to the table below

### USE THESE SAE VISCOSITY OILS

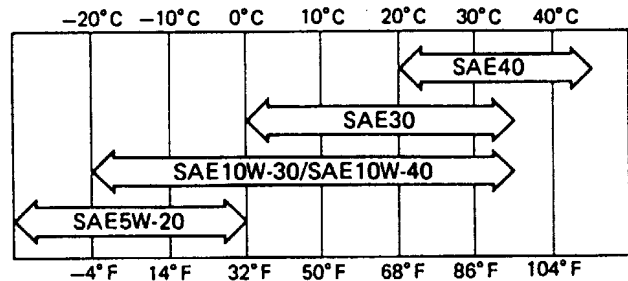

G001463

**Figure 33**

### Checking the Engine Oil Level

1. Park the machine on a level surface.
2. Disengage the PTO, turn the ignition key to off, and remove the key.
3. Wait for all moving parts to stop before leaving the operating position and then chock or block tires.
4. Clean around the oil dipstick (Figure 34) so that dirt cannot fall into the filler hole and damage the engine.

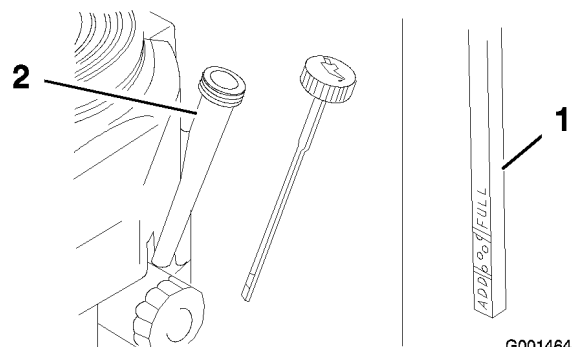

G001464

**Figure 34**

1. Oil dipstick
  2. Filler tube
5. Unscrew the oil dipstick and wipe the end clean (Figure 34).
  6. Slide the oil dipstick fully into the filler tube, but do not thread onto tube (Figure 34).
  7. Pull the dipstick out and look at the metal end. If the oil level is low, slowly pour only enough oil into the filler tube to raise the level to the Full mark.

**Important:** Do not overfill the crankcase with oil and run the engine; engine damage can result.

## Changing the Oil

1. Start the engine and let it run five minutes. This warms the oil so it drains better.
2. Park the machine so that the drain side is slightly lower than the opposite side to assure the oil drains completely.
3. Disengage the PTO and set the parking brake.
4. Stop the engine, remove the key, and wait for all moving parts to stop before leaving the operating position.
5. Slide the drain hose over the oil drain valve.
6. Place a pan below the drain hose. Rotate oil drain valve to allow oil to drain (Figure 35).
7. When oil has drained completely, close the drain valve.
8. Remove the drain hose (Figure 35).

**Note:** Dispose of the used oil at a recycling center.

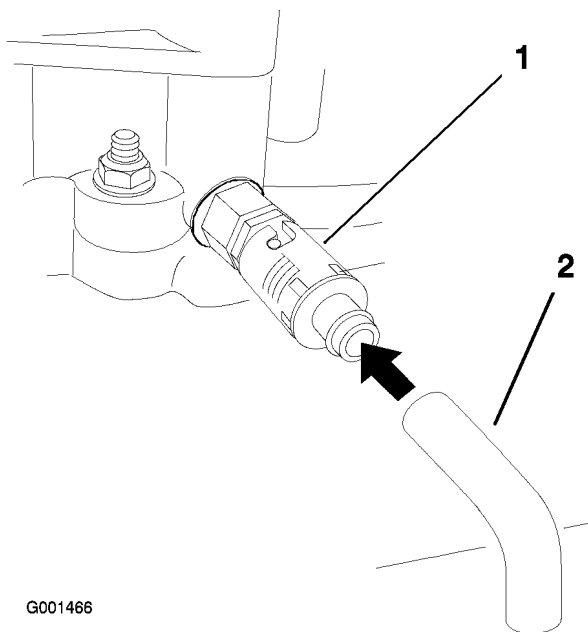

**Figure 35**

1. Oil drain valve
2. Oil drain hose

9. Slowly pour approximately 80% of the specified oil into the filler tube (Figure 34).

10. Check the oil level; refer to Checking the Engine Oil Level.
11. Slowly add the additional oil to bring it to the Full mark.

## Changing the Oil Filter

Replace the oil filter every 200 operating hours or every other oil change.

**Note:** Change the oil filter more frequently when the operating conditions are extremely dusty or sandy.

1. Drain the oil from the engine; refer to Changing the Engine Oil.
2. Remove the old filter (Figure 36).

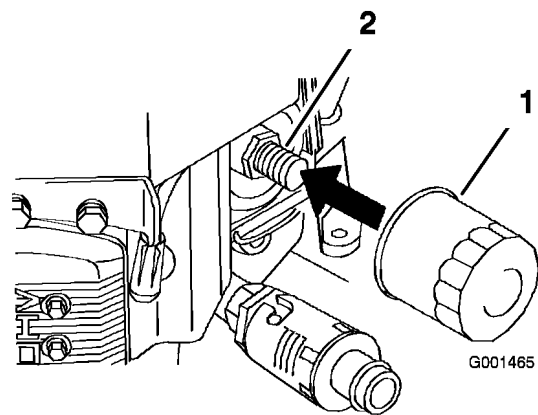

**Figure 36**

1. Oil filter
2. Adapter

3. Apply a thin coat of new oil to the rubber gasket on the replacement filter (Figure 36).
4. Install the replacement oil filter to the filter adapter, turn the oil filter clockwise until the rubber gasket contacts the filter adapter, then tighten the filter an additional 3/4 turn (Figure 36).
5. Fill the crankcase with the proper type of new oil; refer to Servicing the Engine Oil.
6. Run the engine for about 3 minutes, stop the engine, and check for oil leaks around the oil filter.
7. Check the engine oil level and add oil if needed.

# Servicing the Spark Plugs

## Service Interval/Specification

Check the spark plugs after every 100 operating hours.

Ensure that the air gap between the center and side electrodes is correct before installing the spark plug. Use a spark plug wrench for removing and installing the spark plugs and a gapping tool/feeler gauge to check and adjust the air gap. Install a new spark plugs if necessary.

Type: Champion® RCJ8Y or equivalent Air Gap: 0.030 inch (0.75 mm)

## Removing the Spark Plugs

1. Disengage the PTO and set the parking brake.
2. Stop the engine, remove the key, and wait for all moving parts to stop before leaving the operating position.
3. Disconnect the wires from the spark plugs (Figure 37).

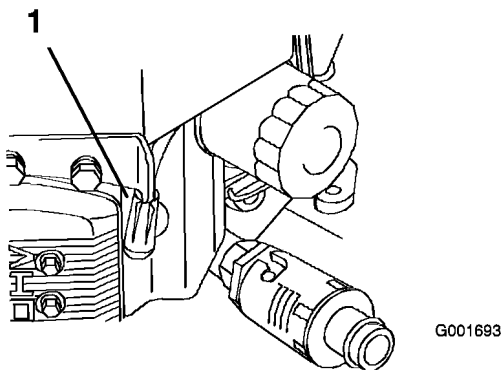

Figure 37

1. Spark-plug wire/spark plug

4. Clean around the spark plugs to prevent dirt from falling into the engine and potentially causing damage.
5. Remove the spark plugs and the metal washers.

## Checking the Spark Plugs

1. Look at the center of the spark plugs (Figure 38). If you see light brown or gray on the insulator, the engine is operating properly. A black coating on the insulator usually means that the air cleaner is dirty.

2. If needed, clean the spark plug with a wire brush to remove carbon deposits.

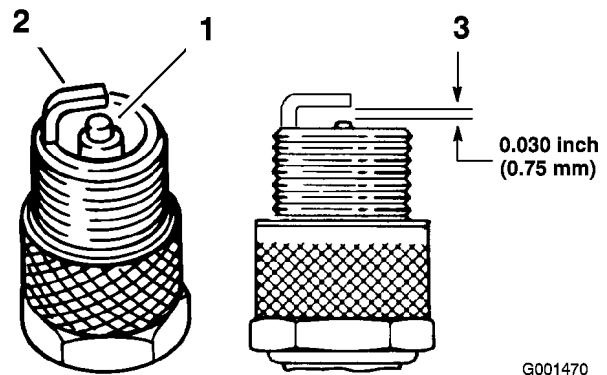

Figure 38

1. Center electrode insulator
2. Side electrode
3. Air gap (not to scale)

**Important:** Always replace the spark plugs when it has a black coating, worn electrodes, an oily film, or cracks.

3. Check the gap between the center and side electrodes (Figure 38). Bend the side electrode (Figure 38) if the gap is not correct.

## Installing the Spark Plugs

1. Install the spark plugs and the metal washer. Ensure that the air gap is set correctly.
2. Tighten the spark plugs to 16 ft-lb (22 N•m).
3. Connect the wires to the spark plugs (Figure 38).

# Fuel System Maintenance

## Replacing the Fuel Filter

Replace the fuel filter after every 200 operating hours or yearly, whichever occurs first.

Never install a dirty filter if it is removed from the fuel line.

1. Disengage the PTO, move the motion control levers to the neutral locked position, and set the parking brake.
2. Stop the engine, remove the key, and wait for all moving parts to stop before leaving the operating position.
3. Allow the machine to cool down.

4. Stop the engine, remove the key, and wait for all moving parts to stop before leaving the operating position.
5. Close the fuel shutoff valve (Figure 39).

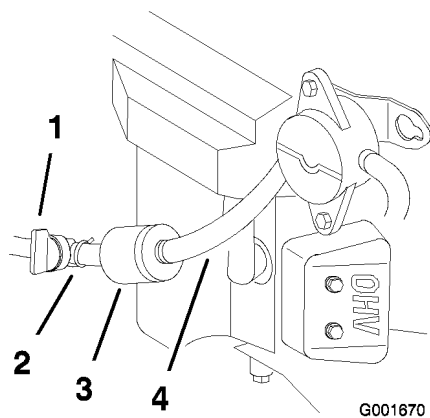

**Figure 39**

- |                       |                |
|-----------------------|----------------|
| 1. Fuel shutoff valve | 3. Fuel line   |
| 2. Hose clamp         | 4. Fuel filter |

6. Squeeze the ends of the hose clamps together and slide them away from the filter (Figure 39).
7. Remove the filter from the fuel lines.
8. Install a new filter and move the hose clamps close to the filter (Figure 39).
9. Open the fuel shutoff valve.

## Servicing the Fuel Tank



In certain conditions, gasoline is extremely flammable and highly explosive. A fire or explosion from gasoline can burn you and others and can damage property.

- Drain gasoline from the fuel tank when the engine is cold. Do this outdoors in an open area. Wipe up any gasoline that spills.
- Never smoke when draining gasoline, and stay away from an open flame or where a spark may ignite the gasoline fumes.

1. Park the machine on a level surface to ensure that the fuel tanks drain completely.
2. Disengage the power takeoff (PTO), set the parking brake, stop the engine, and remove the key.

3. Close the fuel shutoff valve (Figure 39).
4. Loosen the hose clamp at the fuel filter and slide it up the fuel line away from the fuel filter (Figure 39).
5. Disconnect the fuel line from the fuel filter (Figure 39).
6. Open the fuel shutoff valve.
 

**Note:** Allow gasoline to drain into a fuel container can or drain pan (Figure 39).

**Note:** Now is the best time to install a new fuel filter because the fuel tank is empty.
7. Install the fuel line onto the fuel filter. Slide the hose clamp close to the fuel filter to secure the fuel line (Figure 39).

## Electrical System Maintenance

### Servicing the Battery

#### Warning

##### CALIFORNIA Proposition 65 Warning

Battery posts, terminals, and related accessories contain lead and lead compounds, chemicals known to the State of California to cause cancer and reproductive harm. Wash hands after handling.



Battery electrolyte contains sulfuric acid which is a deadly poison and causes severe burns.

Do not drink electrolyte and avoid contact with skin, eyes or clothing. Wear safety glasses to shield your eyes and rubber gloves to protect your hands.

## Removing the Battery



Battery terminals or metal tools could short against metal machine components causing sparks. Sparks can cause the battery gasses to explode, resulting in personal injury.

- When removing or installing the battery, do not allow the battery terminals to touch any metal parts of the machine.
- Do not allow metal tools to short between the battery terminals and metal parts of the machine.



Incorrect battery cable routing could damage the machine and cables causing sparks. Sparks can cause the battery gasses to explode, resulting in personal injury.

- Always Disconnect the negative (black) battery cable before disconnecting the positive (red) cable.
- Always Reconnect the positive (red) battery cable before reconnecting the negative (black) cable.

1. Disengage the PTO, move the motion control levers to the neutral locked position, and set the parking brake.
2. Stop the engine, remove the key, and wait for all moving parts to stop before leaving the operating position.
3. Unlatch the seat and tilt the seat up.
4. First disconnect the negative battery cable and ground wire from the negative (-) battery terminal (Figure 40).
5. Slide the red terminal boot off the positive (red) battery terminal. Then remove the positive (red) battery cable (Figure 40).

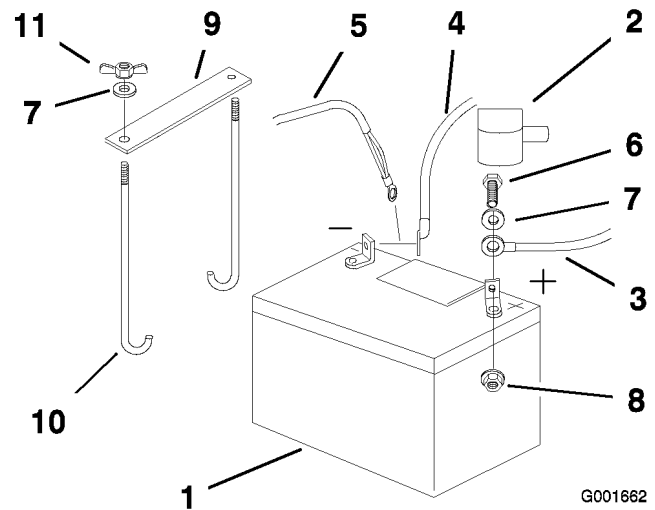

**Figure 40**

- |                           |                        |
|---------------------------|------------------------|
| 1. Battery                | 7. Washer (1/4 inch)   |
| 2. Terminal boot          | 8. Locknut (1/4 inch)  |
| 3. Positive battery cable | 9. Battery clamp       |
| 4. Negative battery cable | 10. J-bolts            |
| 5. Ground wire            | 11. Wingnut (1/4 inch) |
| 6. Bolt (1/4 x 3/4 inch)  |                        |

6. Remove both wing nuts (1/4 inch) securing the battery clamp (Figure 40).
7. Remove the battery.

## Installing the Battery

1. Position battery in the tray with the terminal posts toward the engine (Figure 40).
2. First, install the positive (red) battery cable to positive (+) battery terminal.
3. Then install the negative battery cable and ground wire to the negative (-) battery terminal.
4. Secure the cables with 2 bolts (1/4 x 3/4 inch), 2 washers (1/4 inch), and 2 locknuts (1/4 inch) (Figure 40).
5. Slide the red terminal boot onto the positive (red) battery post.
6. Secure battery with J-bolts, hold down clamp and 2 washers (1/4 inch), and 2 wing nuts (1/4 inch) (Figure 40).

## Charging the Battery



Charging the battery produces gasses that can explode.

Never smoke near the battery and keep sparks and flames away from battery.

**Important:** Always keep the battery fully charged (1.265 specific gravity). This is especially important to prevent battery damage when the temperature is below 32°F (0°C).

1. Charge battery for 10 to 15 minutes at 25 to 30 amps or 30 minutes at 4-6 amps.
2. When the battery is fully charged, unplug the charger from the electrical outlet, then disconnect the charger leads from the battery posts (Figure 41).

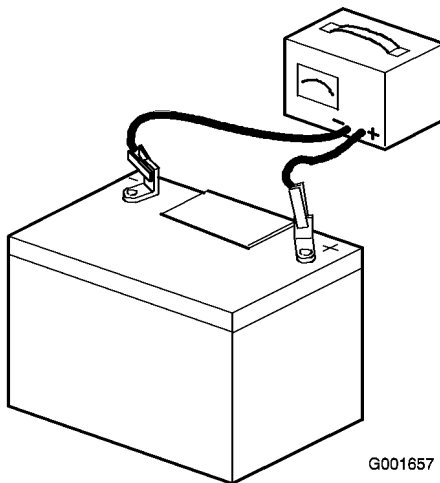

**Figure 41**

1. Positive Battery Post
2. Negative Battery Post
3. Red (+) Charger Lead
4. Black (-) Charger Lead

3. Install the battery in the machine and connect the battery cables; refer to Installing the Battery.

**Note:** Do not run the machine with the battery disconnected, electrical damage may occur.

## Servicing the Fuses

The electrical system is protected by fuses. It requires no maintenance, however, if a fuse blows check component/circuit for malfunction or short.

Fuse:

- Main, F1-30 amp, blade-type
  - Charge circuit, F2-25 amp, blade-type
  - Optional head light kit, 10 amp, blade-type
1. Raise the seat to gain access to the fuse holder (Figure 42).
  2. To replace the fuses, pull out on the fuse to remove it.
  3. Install a new fuse (Figure 42).

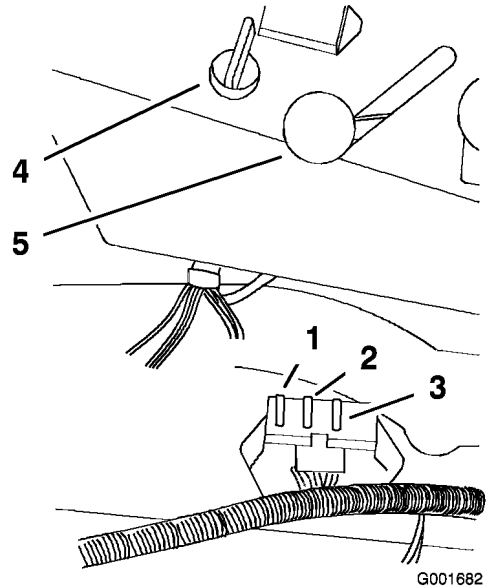

**Figure 42**

1. Main, 30 amp
2. Charge circuit, 25 amp
3. For optional head light kit, 10 amp
4. Ignition switch
5. Throttle lever

# Drive System Maintenance

## Adjusting the Tracking

**Note:** Determine the left and right sides of the machine from the normal operating position.

The machine has a knob for adjusting the tracking located under the seat.

**Important:** Adjust the handle neutral and hydraulic pump neutral before adjusting the tracking. Refer to Adjusting the Handle Neutral in Controls System Maintenance, page 40 and Adjusting the Hydraulic Pump Neutral in Hydraulic System Maintenance, page 41.

1. Push both control levers forward the same distance.
2. Check if the machine pulls to one side. If it does, stop the machine and set the parking brake.
3. Unlatch the seat and tilt the seat forward to access the tracking knob.
4. To make the machine go right, turn the knob towards the rightside of the machine. Refer to Figure 43.
5. To make the machine go left, turn the knob towards the leftside of the machine. Refer to Figure 43.
6. Repeat adjustment until the tracking is correct.

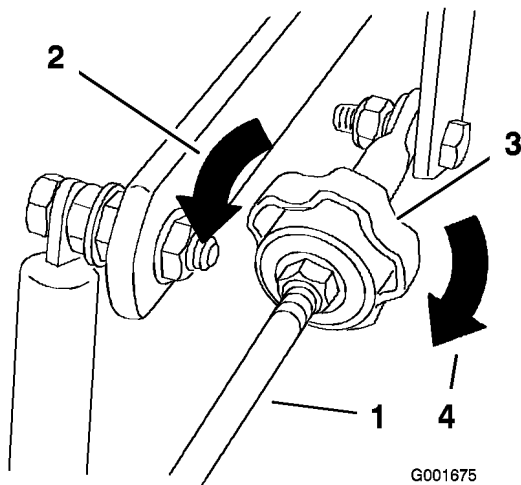

**Figure 43**

- |                                |                                 |
|--------------------------------|---------------------------------|
| 1. Pump rod                    | 3. Tracking knob                |
| 2. Turn this way to track left | 4. Turn this way to track right |

## Checking the Tire Pressure

Check the pressure at the valve stem after every 50 operating hours or monthly, whichever occurs first (Figure 44).

Maintain the air pressure in the front and rear tires at 13 psi (90 kPa). Uneven tire pressure can cause uneven cut. Check the tires when they are cold to get the most accurate pressure reading.

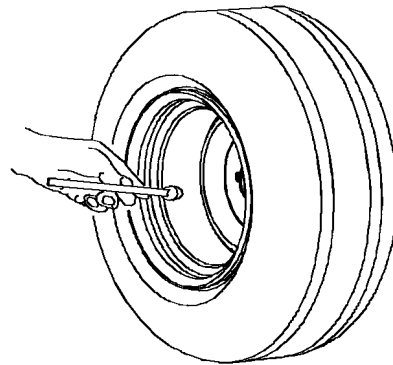

**Figure 44**

## Checking the Wheel Hub Slotted Nut

Check after every 500 operating hours.

The slotted nut needs to be torqued to 125 ft-lb (170 N•m).

1. Disengage the PTO, move the motion control levers to the neutral locked position and set the parking brake.
2. Stop the engine, remove the key, and wait for all moving parts to stop before leaving the operating position.
3. Remove the cotter pin.
4. Torque the slotted nut to 125 ft-lb (170 N•m) (Figure 45).

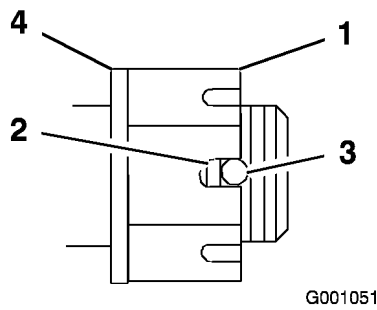

**Figure 45**

- |                                |                           |
|--------------------------------|---------------------------|
| 1. Slotted Nut                 | 3. Hole in threaded shaft |
| 2. Two threads or less showing | 4. Washer (if needed)     |

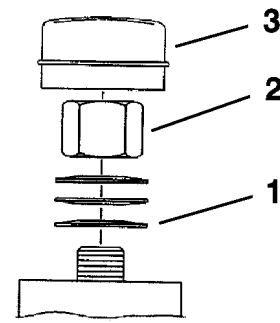

**Figure 46**

- |                   |             |
|-------------------|-------------|
| 1. Spring Washers | 3. Dust Cap |
| 2. Lock Nut       |             |

5. Check the distance from bottom of slot in nut to inside edge of hole. Two threads or less should be showing (Figure 45).
6. If more than two threads are showing remove nut and install washer between hub and nut.
7. Torque the slotted nut to 125 ft-lb. (170 N•m) (Figure 45).
8. Tighten the nut until the next set of slots line up with the hole in the shaft (Figure 45).
9. Replace the cotter pin.

## Adjusting the Caster Pivot Bearing

Check after every 500 operating hours or at storage, whichever comes first.

1. Disengage the PTO, move the motion control levers to the neutral locked position and set the parking brake.
2. Stop the engine, remove the key, and wait for all moving parts to stop before leaving the operating position.
3. Remove the dust cap from caster and tighten lock nut (Figure 46).
4. Tighten the locknut until the spring washers are flat and then back off a 1/4 turn to properly set the pre-load on the bearings (Figure 46).

**Important: Make sure spring washers are installed correctly as shown in Figure 46.**

5. Install the dust cap (Figure 46).

## Cooling System Maintenance

### Cleaning the Air Intake Screen

Before each use remove any build-up of grass, dirt or other debris from the cylinder and cylinder head cooling fins, air intake screen on flywheel end, and carburetor-governor levers and linkage. This will help insure adequate cooling and correct engine speed and will reduce the possibility of overheating and mechanical damage to the engine.

### Cleaning the Cooling System

Clean the air intake screen from grass and debris before each use.

Check and clean cooling fins and engine shrouds every 100 hours or yearly, whichever comes first.

1. Disengage the PTO and set the parking brake.
2. Stop the engine, remove the key, and wait for all moving parts to stop before leaving the operating position.
3. Remove the air intake screen, recoil starter and fan housing (Figure 47).
4. Clean the debris and grass from the engine parts.
5. Install air intake screen, recoil starter and fan housing (Figure 47).

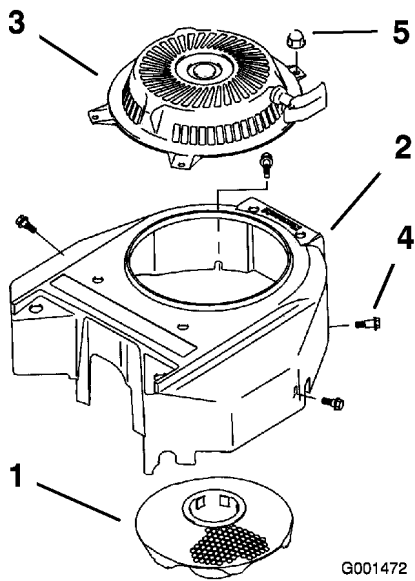

**Figure 47**

- |                      |         |
|----------------------|---------|
| 1. Air intake screen | 4. Bolt |
| 2. Fan housing       | 5. Nut  |
| 3. Recoil starter    |         |

## Brake Maintenance

### Adjusting the Parking Brake

Check the parking brake for proper adjustment.

1. Disengage the brake lever (lever down).
2. Measure the length of the spring; the measurement should be 2-3/4 inch (74 mm) between the washers (Figure 48).

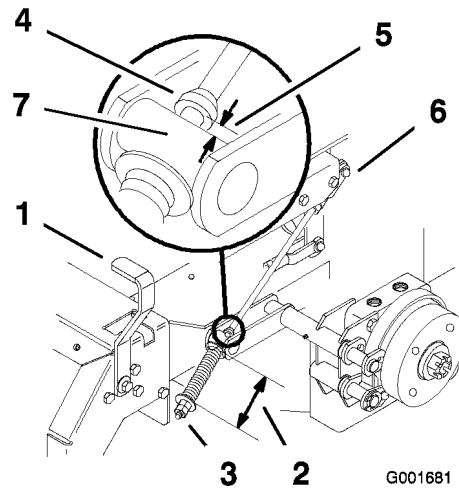

**Figure 48**

- |                               |                                 |
|-------------------------------|---------------------------------|
| 1. Brake lever                | 5. 3/16 to 1/4 inch (5 to 7 mm) |
| 2. Spring, 2-3/4 inch (74 mm) | 6. Jam nut and yoke             |
| 3. Adjusting nuts             | 7. Trunnion                     |
| 4. Collar on brake rod        |                                 |

3. If an adjustment is necessary, do the following:
  - A. Loosen the jam nut below the spring and tighten the nut directly below the yoke (Figure 48).
  - B. Turn the nut until you obtain the correct measurement.
  - C. Tighten the 2 nuts together and repeat on the opposite side of the machine.
4. Turn the nuts clockwise to shorten the spring length; counterclockwise to lengthen the spring.
5. Engage the parking brake, with the lever up.
6. Measure the distance between the trunnion roller and the collar on the brake rod. The measurement should be 3/16 to 1/4 inch (5 to 7 mm) (Figure 48).
7. If an adjustment is necessary, do the following:
  - A. Loosen the jam nut directly below the yoke.
  - B. Turn the bottom adjusting nuts until the correct measurement is obtained (Figure 48).
  - C. Tighten the jam nut at the yoke.

## Belt Maintenance

### Inspecting the Belts

Inspect all belts every 100 hours.

Check belts for cracks, frayed edges, burn marks or any other damage. Replace damaged belts.

## Replacing the Mower Belt

The signs of a worn mower belt are squealing while the belt is rotating, blades slipping while you are cutting grass, frayed belt edges, burn marks, and cracks. Replace the mower belt if you detect any of these signs.

1. Disengage the PTO, move the motion control levers to the neutral locked position, and set the parking brake.
2. Stop the engine, remove the key, and wait for all moving parts to stop before leaving the operating position.
3. Remove the belt covers over the outside spindles.
4. Loosen the fixed idler arm and adjust it to relieve the belt tension on the fixed idler pulley (Figure 49).

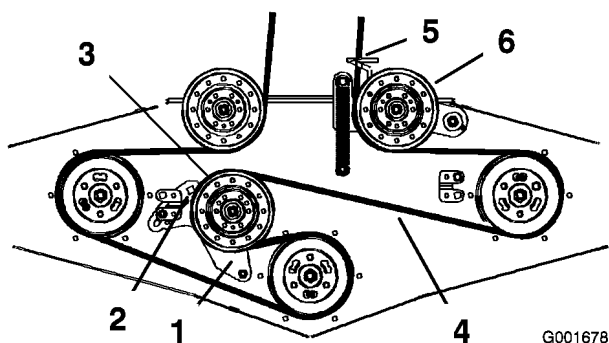

**Figure 49**

- |                       |                               |
|-----------------------|-------------------------------|
| 1. Fixed idler arm    | 4. Mower belt                 |
| 2. Square hole        | 5. Belt guide                 |
| 3. Fixed Idler pulley | 6. Spring-loaded idler pulley |

5. Remove the old belt.
6. Install the new belt through the belt guide and on the pulleys (Figure 49).
7. Insert a ratchet with a short extension or a breaker bar into the square hole in the fixed idler arm (Figure 50).

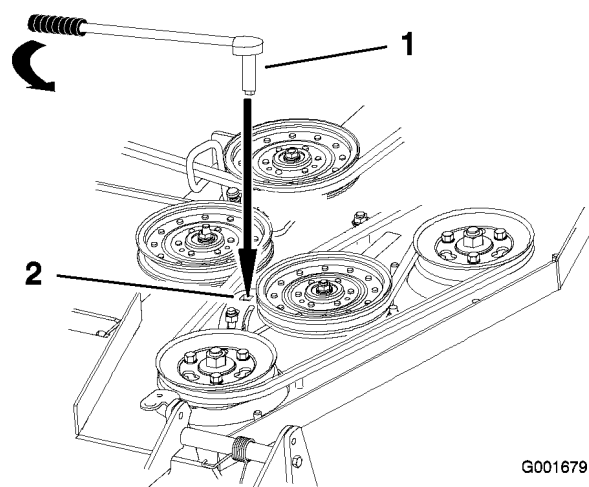

G001679

**Figure 50**

- |  |                |
|--|----------------|
| 1. Ratchet with short extension or breaker bar | 2. Square hole |
|--|----------------|

8. To increase the belt tension, rotate the ratchet or breaker bar counterclockwise to move the fixed idler arm until you feel increased resistance and the spring-loaded idler pulley stops moving.

**Note:** Do not increase the belt tension beyond the point where the fixed idler arm stops.

9. While holding the belt in tension, tighten the 2 bolts that secure the fixed idler arm.
10. Remove the ratchet or breaker bar from the square hole in the fixed idler arm.
11. Install the belt covers over the outside spindles.

## Replacing the Pump Drive Belt

Check the pump drive belt for wear after every 50 operating hours.

1. Remove the mower belt first; refer to Replacing the Mower Belt.
2. Remove the bolt from the clutch stop and unplug the clutch electrical wire (Figure 51).
3. Pull the spring loaded idler to the side.
4. Remove the traction belt from the engine and the hydraulic pump pulleys (Figure 51).
5. Install the new belt around the engine and the hydraulic pump pulleys (Figure 51).
6. Pull the spring-loaded idler to the side and align the belt.

- Release the pressure on the spring loaded idler (Figure 51).
- Install the mower belt.

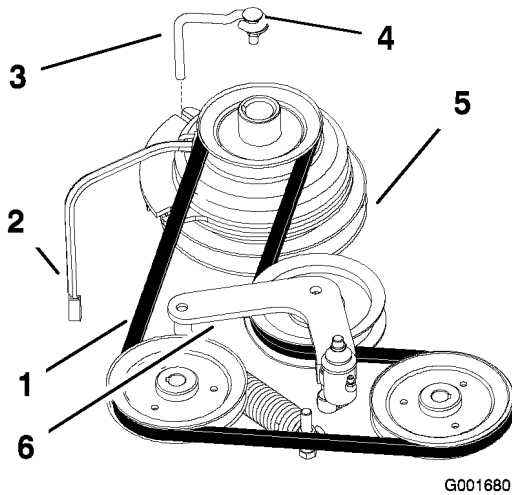

**Figure 51**

- |                           |           |
|---------------------------|-----------|
| 1. Belt                   | 4. Bolt   |
| 2. Clutch electrical wire | 5. Clutch |
| 3. Clutch stop            | 6. Idler  |

## Adjusting the Push Arms

If needed, adjust the push arms to increase or decrease the mower belt tension.

- Loosen the jam nut and rotate the ball joint counterclockwise, one turn at a time (Figure 52).

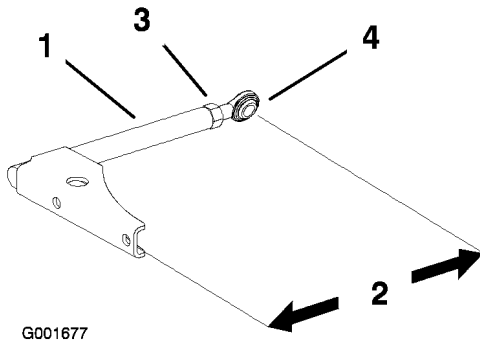

**Figure 52**

- |  |               |
|--|---------------|
| 1. Push arm  | 3. Jam nut    |
| 2. 13-1/2 inch (343 mm) nominal at 15 degree twist | 4. Ball joint |

- Adjust each side the same amount. Each push arm should have a nominal length of 13-1/2 inch (34 cm) at a 15 degree twist (Figure 52).

**Note:** Increase the tension by lengthening the push arms; decrease the tension by shortening the push arms.

## Controls System Maintenance

### Adjusting the Control Handle Neutral Position

If the motion control levers do not align or move easily into the console notch, adjustment them. Adjust each lever, spring, and rod separately.

**Note:** The motion control levers must be installed correctly. See Installing the Motion Control Levers in the Setup instructions.

- Disengage the PTO, move the motion control levers to the neutral locked position, and set the parking brake.
- Stop the engine, remove the key, and wait for all moving parts to stop before leaving the operating position.
- Tilt the seat forward.
- Begin with either the left or right motion control lever.
- Move lever to the neutral position but not locked (Figure 53).

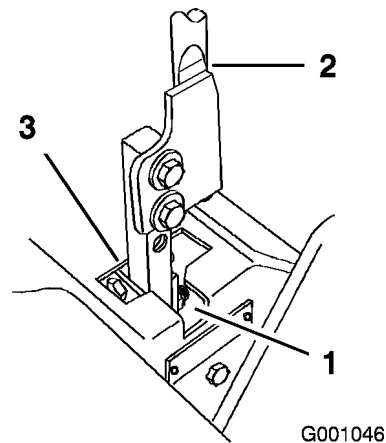

**Figure 53**

- |                            |                     |
|----------------------------|---------------------|
| 1. Neutral locked position | 3. Neutral position |
| 2. Control lever           |                     |

- Pull the lever back until the clevis pin (on the arm below the pivot shaft) contacts the end of the slot (just beginning to put pressure on the spring) (Figure 54).

# Hydraulic System Maintenance

## Servicing the Hydraulic System

### Checking the Hydraulic Fluid

Fluid Type: Mobil 1 15W-50 synthetic motor oil or equivalent synthetic oil.

**Important:** Use oil specified or equivalent. Other fluids could cause system damage.

Hydraulic System Oil Capacity: 67 ounces (2.0 l)

Check the hydraulic fluid level:

- Before the engine is first started.
- After the first 8 operating hours.
- After every 25 operating hours.

**Note:** There are two ways of checking the hydraulic oil. One is when the oil is warm and one is when the oil is cold. The baffle inside the tank has two levels depending if the oil is warm or cold.

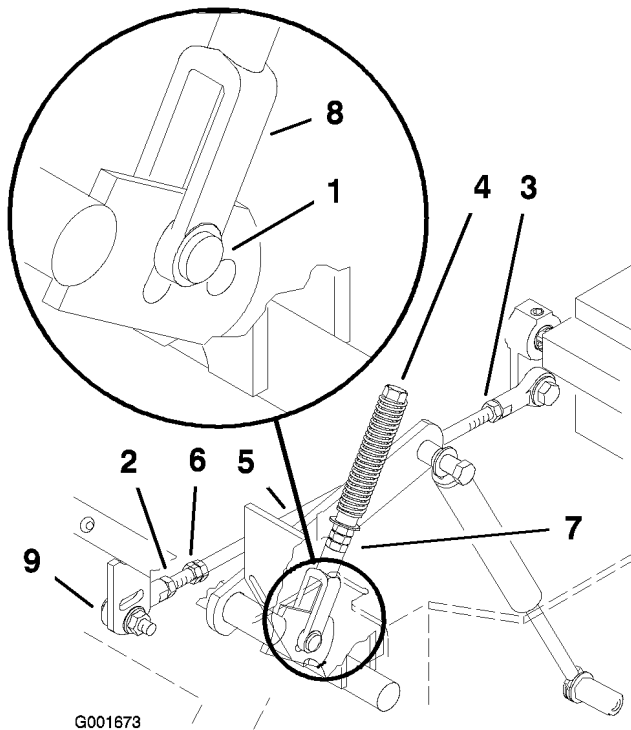

**Figure 54**

- |                         |                |
|-------------------------|----------------|
| 1. Clevis pin in slot   | 6. Double nuts |
| 2. Nut                  | 7. Jam nut     |
| 3. Nut-Left hand thread | 8. Yoke        |
| 4. Adjustment bolt      | 9. Ball joint  |
| 5. Pump rod             |                |

7. Check where the control lever is relative to the notch in the console (Figure 53). It should be centered, allowing the lever to pivot outward to the neutral lock position.
8. If adjustment is needed, loosen the nut and jam nut against the yoke (Figure 54).
9. Apply slight rearward pressure on the motion control lever, and turn the head of the adjustment bolt in the appropriate direction until the control lever is centered in the neutral lock position.  
**Note:** Keeping rearward pressure on the lever will keep the pin at the end of the slot and allow the adjustment bolt to move the lever to the appropriate position.
10. Tighten the nut and jam nut (Figure 54).
11. Repeat on the opposite side of machine.

1. Position the machine on a level surface and set the parking brake.
2. Clean the area around filler neck of hydraulic tank (Figure 55).
3. Remove the cap from the filler neck. Look inside to check if there is fluid in the reservoir (Figure 55).
4. If there is no fluid, add fluid to the reservoir until it reaches the cold level of the baffle.
5. Run the machine at low idle for 15 minutes to allow any air to purge out of the system and warm the fluid. Refer to Starting and Stopping the Engine in Operation, page 14.
6. Recheck the fluid level while the fluid is warm. The fluid should be between cold and hot.
7. If required, add fluid to the hydraulic tank.

**Note:** The fluid level should be to the top of the hot level of the baffle, when the fluid is hot (Figure 55).

8. Install the cap on filler neck.

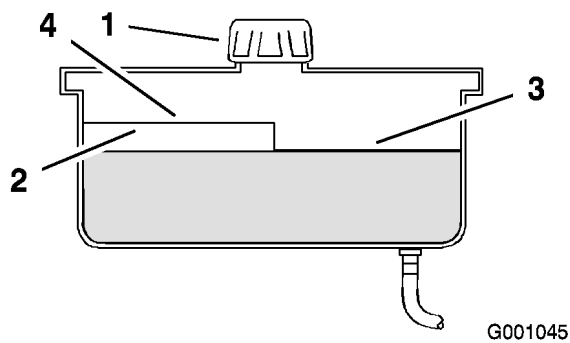

**Figure 55**

- |           |                          |
|-----------|--------------------------|
| 1. Cap    | 3. Cold fluid level-full |
| 2. Baffle | 4. Hot fluid level-full  |

**Hydraulic fluid escaping under pressure can penetrate skin and cause injury.**

- If hydraulic fluid is injected into the skin it must be surgically removed within a few hours by a doctor familiar with this type of injury. Gangrene may result if this is not done.
- Keep body and hands away from pin hole leaks or nozzles that eject high pressure hydraulic fluid.
- Use cardboard or paper to find hydraulic leaks.
- Safely relieve all pressure in the hydraulic system before performing any work on the hydraulic system.
- Make sure all hydraulic fluid hoses and lines are in good condition and all hydraulic connections and fittings are tight before applying pressure to hydraulic system.

## Replacing the Hydraulic Filter and Oil

Change the hydraulic filter and oil:

- After the first 8 operating hours.
- Change yearly after the first 200 operating hours.

Use summer filter above 32°F (0°C)

Use winter filter below 32°F (0°C)

1. Disengage the PTO, move the motion control levers to the neutral locked position and set the parking brake.
2. Stop the engine, remove the key, and wait for all moving parts to stop before leaving the operating position.

**Important: Do not substitute automotive oil filter or severe hydraulic system damage may result.**

3. Place a drain pan under filter, remove the old filter and wipe the filter adapter gasket surface clean (Figure 56).

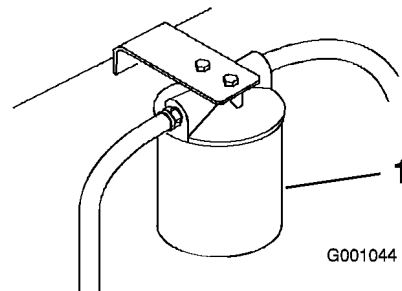

**Figure 56**

1. Hydraulic filter

4. Apply a thin coat to the rubber gasket on the replacement filter (Figure 57).
5. Install the replacement hydraulic filter onto the filter adapter. Do not tighten.
6. Fill the hydraulic tank with hydraulic fluid until the fluid overflows the filter and then turn the oil filter clockwise until the rubber gasket contacts the filter adapter, then tighten the filter an additional 1/2 turn (Figure 57).
7. Clean up any spilled fluid.
8. Add fluid to the cold level of the baffle in the hydraulic tank.
9. Start the engine and let it run for about two minutes to purge air from the system. Stop the engine and check for leaks. If one or both wheels will not drive, refer to Bleeding Hydraulic System.
10. Recheck the fluid level while the fluid is warm. The fluid should be between cold and hot.
11. If required, add fluid to the hydraulic tank. Do not overfill.

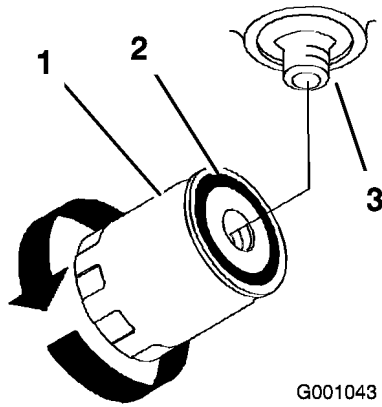

**Figure 57**

1. Hydraulic filter  
2. Gasket  
3. Adapter

## Bleeding the Hydraulic System

The traction system is self bleeding, however, it may be necessary to bleed the system if fluid is changed or after work is performed on the system.

1. Raise rear of the machine so wheels are off the ground and support with jack stands.
2. Start the engine and run at low idle speed. Engage the lever and traction on one side and spin the wheel by hand.
3. When the wheel begins to spin on its own, keep it engaged until wheel drives smoothly. (minimum 2 minutes)
4. Check the hydraulic fluid level and add as required to maintain proper level.
5. Repeat this procedure on the opposite wheel.

## Checking the Hydraulic Hoses

After every 100 operating hours, check the hydraulic hoses for leaks, loose fittings, kinked lines, loose mounting supports, wear, weather and chemical deterioration. Make necessary repairs before operating.

**Note:** Keep areas around the hydraulic system clean from grass and debris build up.



Hydraulic fluid escaping under pressure can penetrate skin and cause injury.

- If hydraulic fluid is injected into the skin it must be surgically removed within a few hours by a doctor familiar with this type of injury. Gangrene may result if this is not done.
- Keep body and hands away from pin hole leaks or nozzles that eject high pressure hydraulic fluid.
- Use cardboard or paper to find hydraulic leaks.
- Safely relieve all pressure in the hydraulic system before performing any work on the hydraulic system.
- Make sure all hydraulic fluid hoses and lines are in good condition and all hydraulic connections and fittings are tight before applying pressure to hydraulic system.

## Setting the Hydraulic Pump Neutral Position

**Note:** Adjust the handle neutral first. That needs to be correct before the following adjustment can be made.

This adjustment must be made with drive wheels turning.



Mechanical or hydraulic jacks may fail to support machine and cause a serious injury.

- Use jack stand when supporting machine.
- Do not use hydraulic jacks.



Engine must be running so motion control adjustment can be performed. Contact with moving parts or hot surfaces may cause personal injury.

Keep hands, feet, face, clothing and other body parts away from rotating parts, muffler and other hot surfaces.

1. Raise the frame and block up the machine so drive wheels can rotate freely.
2. Disconnect the electrical connector from the seat safety switch. **Temporarily** install a jumper wire across terminals in the wiring harness connector.
3. Unlatch the seat and slide seat forward.
4. Disconnect the seat rod and tilt the seat fully forward.

### Setting the Left-hand Hydraulic Pump Neutral Position

1. Start the engine, open the throttle 1/2 way and release parking brake. Refer to Starting and Stopping the Engine in Operation, page 14.  
**Note:** The motion control lever must be in neutral while making any adjustments.
2. Adjust the pump rod length by rotating the knob, in the appropriate direction, until the wheel is still or slightly creeping in reverse (Figure 58).
3. Move the motion control lever forward and reverse, then back to neutral. The wheel must stop turning or slightly creep in reverse.
4. Open the throttle to fast. Make sure wheel remains stopped or slightly creeps in reverse, adjust if necessary.

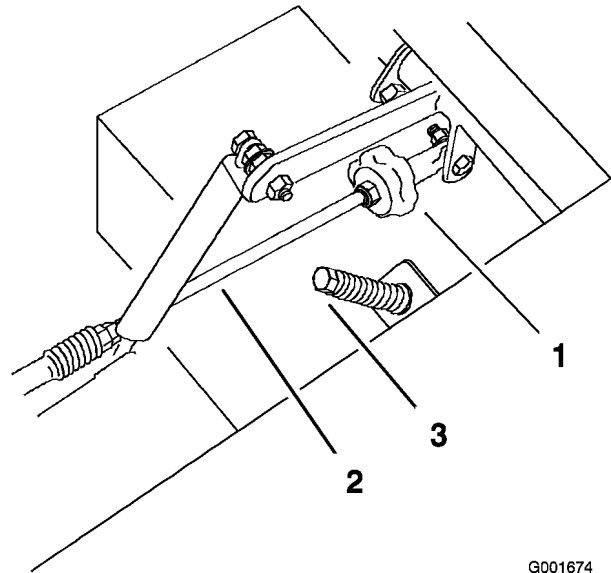
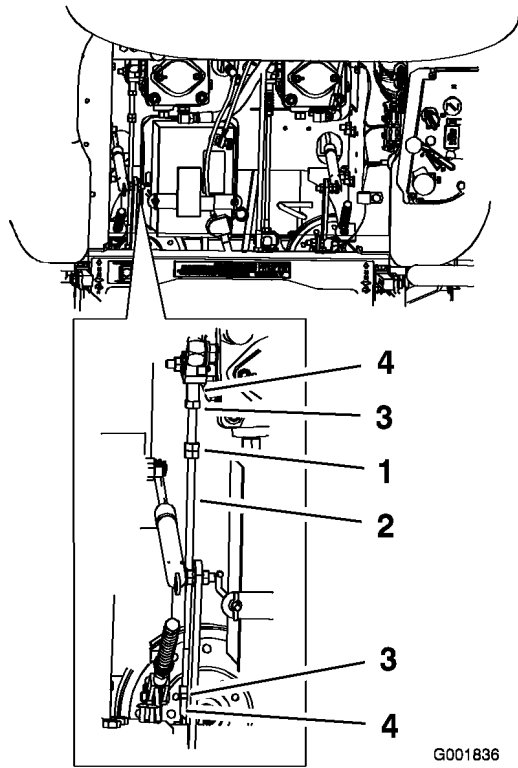

Figure 58

1. Tracking knob
2. Pump rod
3. Adjustment bolt

### Setting the Right-hand Hydraulic Pump Neutral Position

1. Loosen the locknuts at the ball joints on the pump control rod (Figure 59).
2. Start the engine, open throttle 1/2 way and release parking brake. Refer to Starting and Stopping the Engine in Operation, page 14.  
**Note:** The motion control lever must be in neutral while making any adjustments.
- Note:** The front nut on the pump rod has left-hand threads.
3. Adjust the pump rod length by rotating double nuts on the rod, in the appropriate direction, until the wheel is still or slightly creeps in reverse (Figure 59).
4. Move the motion control lever forward and reverse, then back to neutral. The wheel must stop turning or slightly creep in reverse.
5. Open the throttle to fast. Make sure the wheel remains stopped or slightly creeps in reverse, adjust if necessary.
6. Tighten the locknuts at the ball joints (Figure 59).



**Figure 59**

- |                |               |
|----------------|---------------|
| 1. Double nuts | 3. Locknut    |
| 2. Pump rod    | 4. Ball joint |

**Electrical system will not perform proper safety shut off with jumper wire installed.**

- Remove jumper wire from wire harness connector and plug connector into seat switch when adjustment is completed.
- Never operate this unit with jumper installed and seat switch bypassed.

7. After both pump neutrals are set, shut off the machine.
8. Remove the jumper wire from the wire harness connector and plug the connector into the seat switch.
9. Install the seat rod and lower the seat into position.
10. Remove the jack stands.

## Mower Deck Maintenance

### Leveling the Mower at Three Positions

**Important:** There are only three measuring positions needed to level the mower.

#### Setting Up the Machine

1. Position mower on a flat surface.
2. Disengage the PTO, move the motion control levers to the neutral locked position and set the parking brake.
3. Stop the engine, remove the key, and wait for all moving parts to stop before leaving the operating position.
4. Check tire pressure of all four tires. If needed, adjust to 13 psi (90 kPa)
5. Lower the mower to the 3 inch (76 mm) height-of-cut position.
6. Inspect the four chains. The chains need to have tension.

**Note:** Adjust the rear chains to the top of the slot, where they are attached to the mower.

- If one rear chain is loose, lower (loosen) the front support arm on the same side. Refer to Adjusting the Front-to-Rear Mower Pitch.
- If one front chain is loose, raise (tighten) the front support arm for that chain. Refer to Adjusting the Front-to-Rear Mower Pitch.

#### Leveling the Mower Side-to-Side

1. Position the right blade front-to-rear (Figure 60).
2. Measure the right blade at the **B** location, from a level surface to the cutting edge of the blade tip (Figure 60).
3. Record this measurement. This measurement needs to be 3-1/8 to 3-1/4 inches.
4. Position the left blade front-to-rear (Figure 60).
5. Measure the left blade at the **C** location (Figure 60), from a level surface to the cutting edge of the blade tip .
6. Record this measurement. This measurement needs to be 3-1/8 to 3-1/4 inches (79 to 83mm).

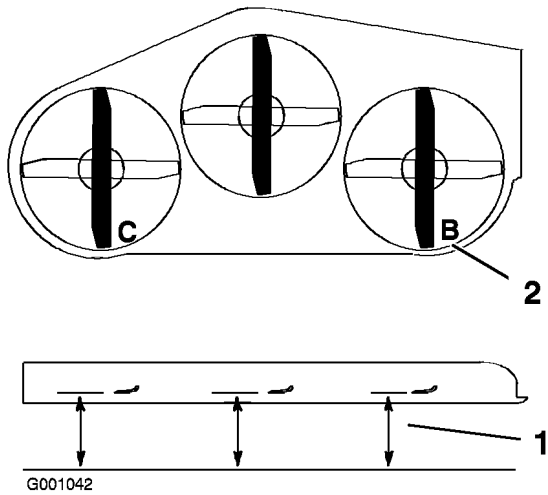

**Figure 60**

1. Measure here from blade
2. Measure at B and C to hard surface

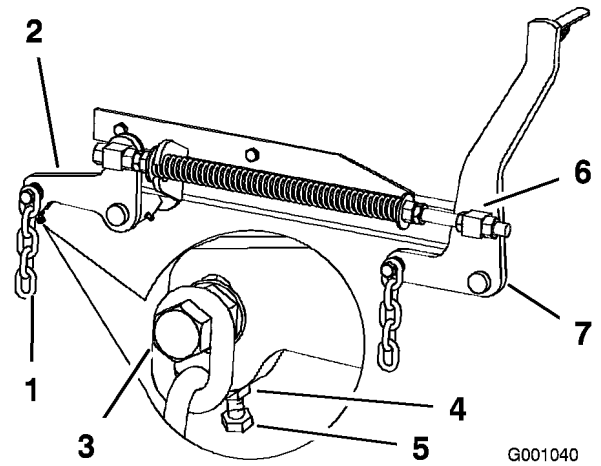

**Figure 61**

1. Rear chain
2. Rear support arm
3. Bolt
4. Jam Nut
5. Adjustment bolt
6. Front swivel
7. Front support arm

7. If the measurements at positions **B** or **C** are not correct, loosen the bolt attaching the rear chain to the rear support arm (Figure 61).
  8. Loosen the jam nut under the rear support arm and adjust the adjustment bolt to get a measurement of 3-1/8 to 3-1/4 inches (Figure 61).
- Note:** It is recommended that both sides of the mower are adjusted the same distance.
9. Tighten the jam nut under the rear support arm and tighten the bolt securing the chain to the rear support arm.
  10. Adjust the opposite side if needed.

### Adjusting the Front-to-Rear Mower Pitch

1. Position the right blade front-to-rear (Figure 62).
2. Measure the right blade at the **A** location, from a level surface to the cutting edge of the blade tip (Figure 62).

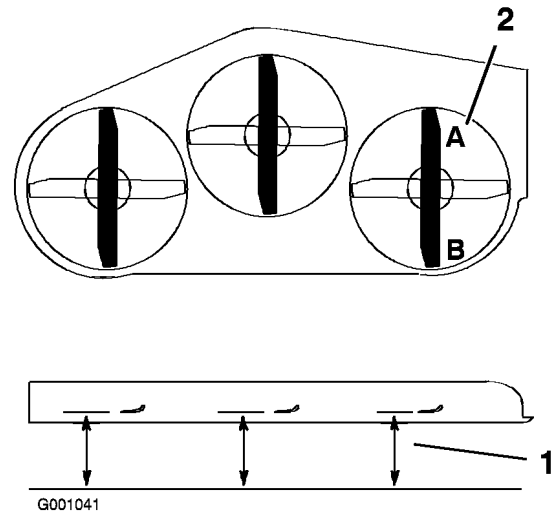

**Figure 62**

1. Measure here from blade
2. Measure at A and B to hard surface

3. Record this measurement.

4. Measure the right blade at the **B** location, from a level surface to the cutting edge of the blade tip (Figure 62).
5. Record this measurement.
6. The mower blade should be a 1/4 to 3/8 inch (6 to 10 mm) lower at position **A** than at position **B** (Figure 62). If it is not correct, proceed to the following steps.

**Note:** Both of the front swivels need to be adjusted the same amount to maintain equal chain tension.

7. Loosen the front swivel jam nuts, at the front of the right and left swivels, approximately a 1/2 inch (13 mm) (Figure 61).
8. Adjust the lift nuts on both the left and the right side of the machine to achieve 1/4 to 3/8 inch (6 to 10 mm) lower in front at **A** than in the rear at **B** (Figure 61).
9. Tighten both swivel jam nuts against the front swivel to lock the height.
10. Check to make sure there is equal tension on the chains and adjust again if needed.

### Adjusting the Compression Spring

1. Raise the mower lift lever to the transport position.
2. Check the distance between the two large washers, it needs to be 11-1/8 inches (28.2 cm) for 52 inch mower decks and 10-1/2 inches (26.7 cm) for 60 inch mower decks (Figure 63).
3. Adjust this distance, by loosening the spring jam nut and turning the nut in front of each spring (Figure 63).

**Note:** Turning the nut clockwise will shorten the spring; counter-clockwise will lengthen the spring.

4. Lock the nut into position by tightening the spring jam nut (Figure 63).

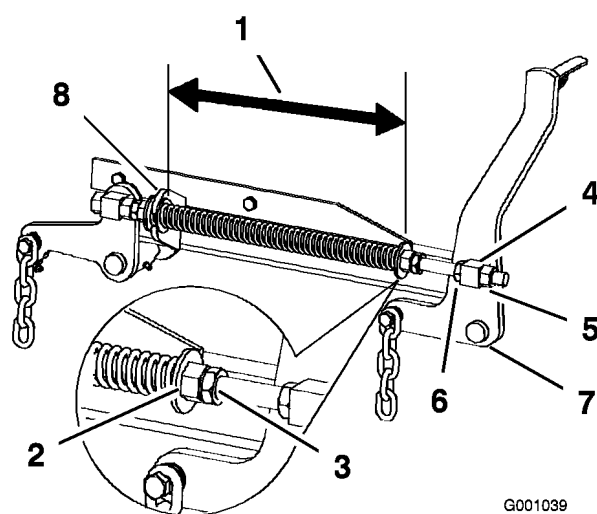

**Figure 63**

- |                          |                      |
|--------------------------|----------------------|
| 1. 10-1/2 inch (26.7 cm) | 5. Swivel jam nut    |
| 2. Front nut             | 6. Lift nut          |
| 3. Spring jam nut        | 7. Front support arm |
| 4. Front swivel          | 8. Large washer      |

## Servicing the Cutting Blades

Maintain sharp blades throughout the cutting season because sharp blades cut cleanly without tearing or shredding the grass blades. Tearing and shredding turns grass brown at the edges, which slows growth and increases the chance of disease.

Check the cutter blades daily for sharpness, and for any wear or damage. File down any nicks and sharpen the blades as necessary. If a blade is damaged or worn, replace it immediately with a genuine Toro replacement blade. For convenient sharpening and replacement, you may want to keep extra blades on hand.



**A worn or damaged blade can break, and a piece of the blade could be thrown into the operator's or bystander's area, resulting in serious personal injury or death.**

- Inspect the blade periodically for wear or damage.
- Replace a worn or damaged blade.

Inspect and check the blades every 8 hours.

## Before Inspecting or Servicing the Blades

Park the machine on a level surface, disengage the blade control (PTO), and set the parking brake. Turn the ignition key to Off. Remove the key.

## Inspecting the Blades

1. Inspect the cutting edges (Figure 64). If the edges are not sharp or have nicks, remove and sharpen the blades. Refer to Sharpening the Blades.
2. Inspect the blades, especially the curved area (Figure 64). If you notice any damage, wear, or a slot forming in this area (Figure 64), immediately install a new blade.

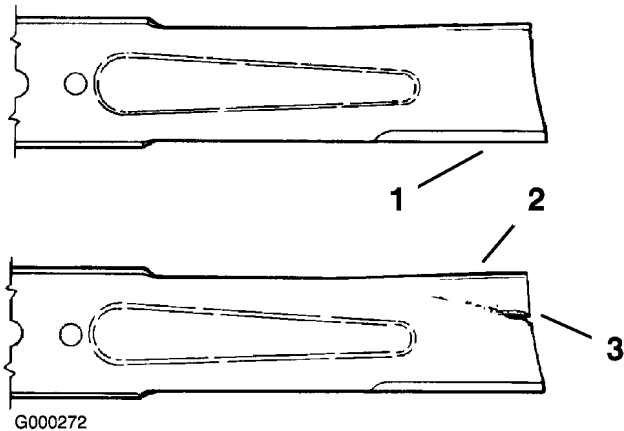
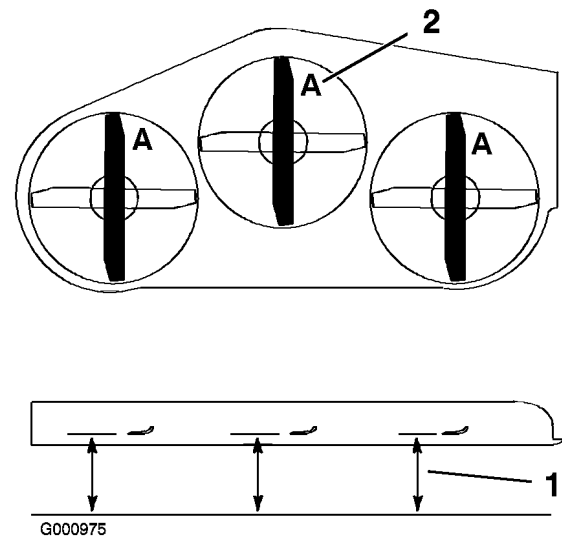

**Figure 64**

1. Cutting Edge
2. Curved Area
3. Wear/slot Forming

## Checking for Bent Blades

1. Disengage the PTO, move the motion control levers to the neutral locked position and set the parking brake.
2. Stop the engine, remove the key, and wait for all moving parts to stop before leaving the operating position.
3. Rotate the blades until the ends face forward and backward (Figure 65). Measure from a level surface to the cutting edge, position **A**, of the blades (Figure 65). Note this dimension.



**Figure 65**

1. Measure here from blade to hard surface
2. Position A

4. Rotate the opposite ends of the blades forward.
5. Measure from a level surface to the cutting edge of the blades at the same position as in step 3 above. The difference between the dimensions obtained in steps 3 and 4 must not exceed 1/8 inch (3 mm). If this dimension exceeds 1/8 inch (3 mm), the blade is bent and must be replaced; refer to Removing the Blades and Installing the Blades.



**A blade that is bent or damaged could break apart and could seriously injure or kill you or bystanders.**

- Always replace bent or damaged blade with a new blade.
- Never file or create sharp notches in the edges or surfaces of blade.

## Removing the Blades

Blades must be replaced if a solid object is hit, if the blade is out of balance or is bent. To ensure optimum performance and continued safety conformance of the machine, use genuine Toro replacement blades. Replacement blades made by other manufacturers may result in non-conformance with safety standards.



Contact with a sharp blade can cause serious injury.

Wear gloves or wrap sharp edges of the blade with a rag.

1. Hold the blade end using a rag or thickly-padded glove.
2. Remove the blade bolt, spring disk and blade from the spindle shaft (Figure 68).

### Sharpening the Blades



When sharpening blade, pieces of blade could be thrown and cause serious injury.

Wear proper eye protection when sharpening blade.

1. Use a file to sharpen the cutting edge at both ends of the blade (Figure 66). Maintain the original angle. The blade retains its balance if the same amount of material is removed from both cutting edges.

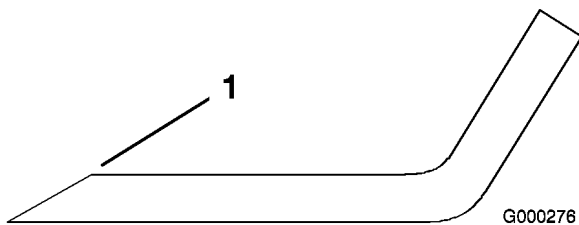

**Figure 66**

1. Sharpen at original angle

2. Check the balance of the blade by putting it on a blade balancer (Figure 67). If the blade stays in a horizontal position, the blade is balanced and can be used. If the blade is not balanced, file some metal off the end of the sail area only (Figure 68). Repeat this procedure until the blade is balanced.

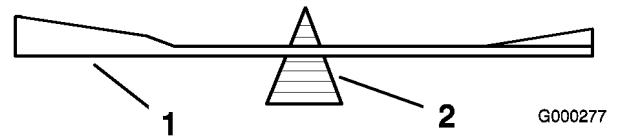

**Figure 67**

1. Blade
2. Balancer

### Installing the Blades

1. Install the blade onto the spindle shaft (Figure 68).

**Important:** The curved part of the blade must be pointing upward toward the inside of the mower to ensure proper cutting.

2. Install the spring disk and blade bolt. The spring disk cone must be installed toward the bolt head (Figure 68). Torque the blade bolt to 85-110 ft-lb (115-150 N•m).

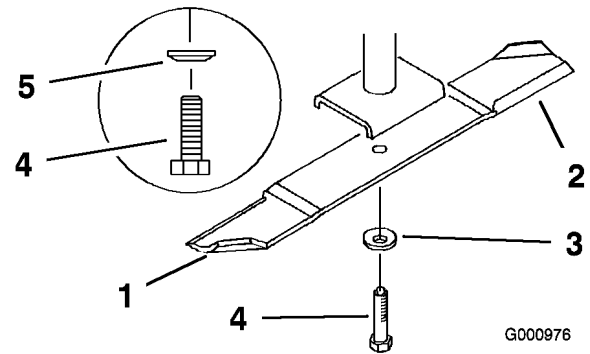

**Figure 68**

1. Sail Area of Blade
2. Blade
3. Spring Disk
4. Blade Bolt
5. Cone Towards Bolt Head

# Replacing the Grass Deflector



An uncovered discharge opening could allow the lawn mower to throw objects in the operator's or bystander's direction and result in serious injury. Also, contact with the blade could occur.

- Never operate the lawn mower unless you install a cover plate, a mulch plate, or a grass chute and catcher.
- Make sure the grass deflector is in the down position.

1. Remove the locknut, bolt, spring and spacer holding the deflector to the pivot brackets (Figure 69). Remove the damaged or worn grass deflector.
2. Place the spacer and spring onto grass deflector. Place the **L** end of spring behind deck edge.

**Note:** Make sure the L end of the spring is installed behind the deck edge before installing the bolt as shown in Figure 69.

3. Install the bolt and nut. Place the **J** hook end of the spring around the grass deflector (Figure 69).

**Important:** The grass deflector must be able to lower down into position. Lift the deflector up to test that it lowers into the full down position.

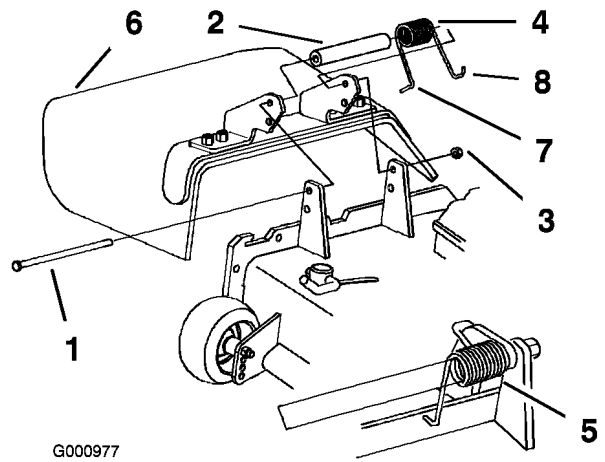

G000977

**Figure 69**

- |            |   |
|------------|---|
| 1. Bolt    | 5. Spring installed   |
| 2. Spacer  | 6. Grass Deflector  |
| 3. Locknut | 7. L end of spring, place behind deck edge before installing bolt |
| 4. Spring  | 8. J hook end of spring   |

## Cleaning

### Cleaning Under the Mower

Remove the grass buildup under the mower daily.

1. Disengage the PTO, move the motion control levers to the neutral locked position and set the parking brake.
2. Stop the engine, remove the key, and wait for all moving parts to stop before leaving the operating position.
3. Raise the mower to the transport position.
4. Lift the front of the machine and support the machine using jack stands.

### Waste Disposal

Engine oil, batteries, hydraulic oil, and engine coolant are pollutants to the environment. Dispose of these according to your state and local regulations.

# Storage

1. Disengage the power take off (PTO), set the parking brake, and turn the ignition key to Off. Remove the key.
2. Remove grass clippings, dirt, and grime from the external parts of the entire machine, especially the engine and hydraulic system. Clean dirt and chaff from the outside of the engine cylinder head fins and blower housing.

**Important:** You can wash the machine with mild detergent and water. Do not pressure wash the machine. Avoid excessive use of water, especially near the control panel, engine, hydraulic pumps, and motors.

3. Check the brake; refer to Servicing the Brake in Brake Maintenance, page 38.
4. Service the air cleaner; refer to Servicing the Air Cleaner in Engine Maintenance, page 29.
5. Grease the machine; refer to Greasing and Lubrication in Lubrication, page 28.
6. Change the crankcase oil; refer to Servicing the Engine Oil in Engine Maintenance, page 29.
7. Check the tire pressure; refer to Checking the Tire Pressure in Drive System Maintenance, page 36.
8. Change the hydraulic filter; refer to Servicing the Hydraulic System in Hydraulic System Maintenance, page 41.
9. Charge the battery; refer to Servicing the Battery in Electrical System Maintenance, page 33.
10. Scrape any heavy buildup of grass and dirt from the underside of the mower, then wash the mower with a garden hose.

**Note:** Run the machine with the PTO engaged and the engine at high idle for 2 to 5 minutes after washing.

11. Check the condition of the blades; refer to Servicing the Cutting Blades in Mower Deck Maintenance, page 45.
12. Prepare the machine for storage when non-use occurs over 30 days. Prepare the machine for storage as follows:

- A. Add a petroleum based stabilizer/conditioner to fuel in the tank. Follow mixing instructions from the stabilizer manufacturer. Do not use an alcohol based stabilizer (ethanol or methanol).

**Note:** A fuel stabilizer/conditioner is most effective when mixed with fresh fuel and used at all times.
- B. Run the engine to distribute conditioned fuel through the fuel system (5 minutes).
- C. Stop the engine, allow it to cool, and drain the fuel tank; refer to Servicing the Fuel Tank in Fuel System Maintenance, page 32.
- D. Restart the engine and run it until it stops.
- E. Dispose of fuel properly. Recycle as per local codes.

**Important:** Do not store stabilizer/conditioned fuel over 90 days.

13. Check and tighten all bolts, nuts, and screws. Repair or replace any part that is damaged.
14. Paint all scratched or bare metal surfaces. Paint is available from your Authorized Service Dealer.
15. Store the machine in a clean, dry garage or storage area. Remove the key from the ignition switch and keep it out of reach of children or other unauthorized users. Cover the machine to protect it and keep it clean.

# Troubleshooting

Problem	Possible Cause	Corrective Action
Starter does not crank	<ol style="list-style-type: none"> <li>1. Blade control (PTO) is engaged.</li> <li>2. Parking brake is not on.</li> <li>3. Operator is not seated.</li> <li>4. Battery is dead.</li> <li>5. Electrical connections are corroded or loose.</li> <li>6. Fuse is blown.</li> <li>7. Relay or switch is defective.</li> </ol>	<ol style="list-style-type: none"> <li>1. Move the blade control (PTO) to disengaged.</li> <li>2. Set the parking brake.</li> <li>3. Sit on the seat.</li> <li>4. Charge the battery.</li> <li>5. Check the electrical connections for good contact.</li> <li>6. Replace the fuse.</li> <li>7. Contact an Authorized Service Dealer.</li> </ol>
Engine will not start, starts hard, or fails to keep running.	<ol style="list-style-type: none"> <li>1. Fuel tank is empty.</li> <li>2. Air cleaner is dirty.</li> <li>3. Dirt in the fuel filter.</li> <li>4. Dirt, water, or stale fuel is in the fuel system.</li> </ol>	<ol style="list-style-type: none"> <li>1. Fill the fuel tank with fuel.</li> <li>2. Clean or replace the air cleaner element.</li> <li>3. Replace the fuel filter.</li> <li>4. Contact an Authorized Service Dealer.</li> </ol>
Engine loses power.	<ol style="list-style-type: none"> <li>1. Engine load is excessive.</li> <li>2. Air cleaner is dirty.</li> <li>3. Oil level in the crankcase is low.</li> <li>4. Cooling fins and air passages above the engine are plugged.</li> <li>5. Vent hole in the fuel cap is plugged.</li> <li>6. Dirt in the fuel filter.</li> <li>7. Dirt, water, or stale fuel is in the fuel system.</li> </ol>	<ol style="list-style-type: none"> <li>1. Reduce the ground speed.</li> <li>2. Clean the air cleaner element.</li> <li>3. Add oil to the crankcase.</li> <li>4. Remove the obstruction from the cooling fins and air passages.</li> <li>5. Clean or replace the fuel cap.</li> <li>6. Replace the fuel filter.</li> <li>7. Contact an Authorized Service Dealer.</li> </ol>
Engine overheats.	<ol style="list-style-type: none"> <li>1. Engine load is excessive.</li> <li>2. Oil level in the crankcase is low.</li> <li>3. Cooling fins and air passages above the engine are plugged.</li> </ol>	<ol style="list-style-type: none"> <li>1. Reduce the ground speed.</li> <li>2. Add oil to the crankcase.</li> <li>3. Remove the obstruction from the cooling fins and air passages.</li> </ol>

<b>Problem</b>	<b>Possible Cause</b>	<b>Corrective Action</b>
Machine does not drive.	<ol style="list-style-type: none"> <li>1. By pass valve is not closed tight.</li> <li>2. Drive or pump belt is worn, loose or broken.</li> <li>3. Drive or pump belt is off a pulley.</li> <li>4. Broken or missing idler spring.</li> <li>5. Hydraulic fluid level is low or too hot.</li> </ol>	<ol style="list-style-type: none"> <li>1. Tighten the by pass valve.</li> <li>2. Change the belt.</li> <li>3. Change the belt.</li> <li>4. Replace the spring.</li> <li>5. Add hydraulic fluid to reservoir or let it cool down.</li> </ol>
Abnormal vibration.	<ol style="list-style-type: none"> <li>1. Cutting blade(s) is/are bent or unbalanced.</li> <li>2. Blade mounting bolt is loose.</li> <li>3. Engine mounting bolts are loose.</li> <li>4. Loose engine pulley, idler pulley, or blade pulley.</li> <li>5. Engine pulley is damaged.</li> <li>6. Blade spindle is bent.</li> <li>7. Motor mount is loose or worn.</li> </ol>	<ol style="list-style-type: none"> <li>1. Install new cutting blade(s).</li> <li>2. Tighten the blade mounting bolt.</li> <li>3. Tighten the engine mounting bolts.</li> <li>4. Tighten the appropriate pulley.</li> <li>5. Contact an Authorized Service Dealer.</li> <li>6. Contact an Authorized Service Dealer.</li> <li>7. Contact an Authorized Service Dealer.</li> </ol>
Uneven cutting height.	<ol style="list-style-type: none"> <li>1. Blade(s) not sharp.</li> <li>2. Cutting blade(s) is/are bent.</li> <li>3. Mower is not level.</li> <li>4. Underside of mower is dirty.</li> <li>5. Tire pressure is not correct.</li> <li>6. Blade spindle bent.</li> </ol>	<ol style="list-style-type: none"> <li>1. Sharpen the blade(s).</li> <li>2. Install new cutting blade(s).</li> <li>3. Level the mower from side-to-side and front-to-rear.</li> <li>4. Clean the underside of the mower.</li> <li>5. Adjust the tire pressure.</li> <li>6. Contact an Authorized Service Dealer.</li> </ol>

<b>Problem</b>	<b>Possible Cause</b>	<b>Corrective Action</b>
Blades do not rotate.	<ol style="list-style-type: none"> <li>1. Drive belt is worn, loose or broken.</li> <li>2. Drive belt is off pulley.</li> <li>3. Deck belt is worn, loose or broken.</li> <li>4. Deck belt is off pulley.</li> <li>5. Broken or missing idler spring.</li> </ol>	<ol style="list-style-type: none"> <li>1. Check the belt tension.</li> <li>2. Install the drive belt and check adjusting shafts and belt guides for correct position.</li> <li>3. Install a new deck belt.</li> <li>4. Install the deck pulley and check the idler pulley, idler arm and spring for correct position and function.</li> <li>5. Replace the spring.</li> </ol>

# Schematics

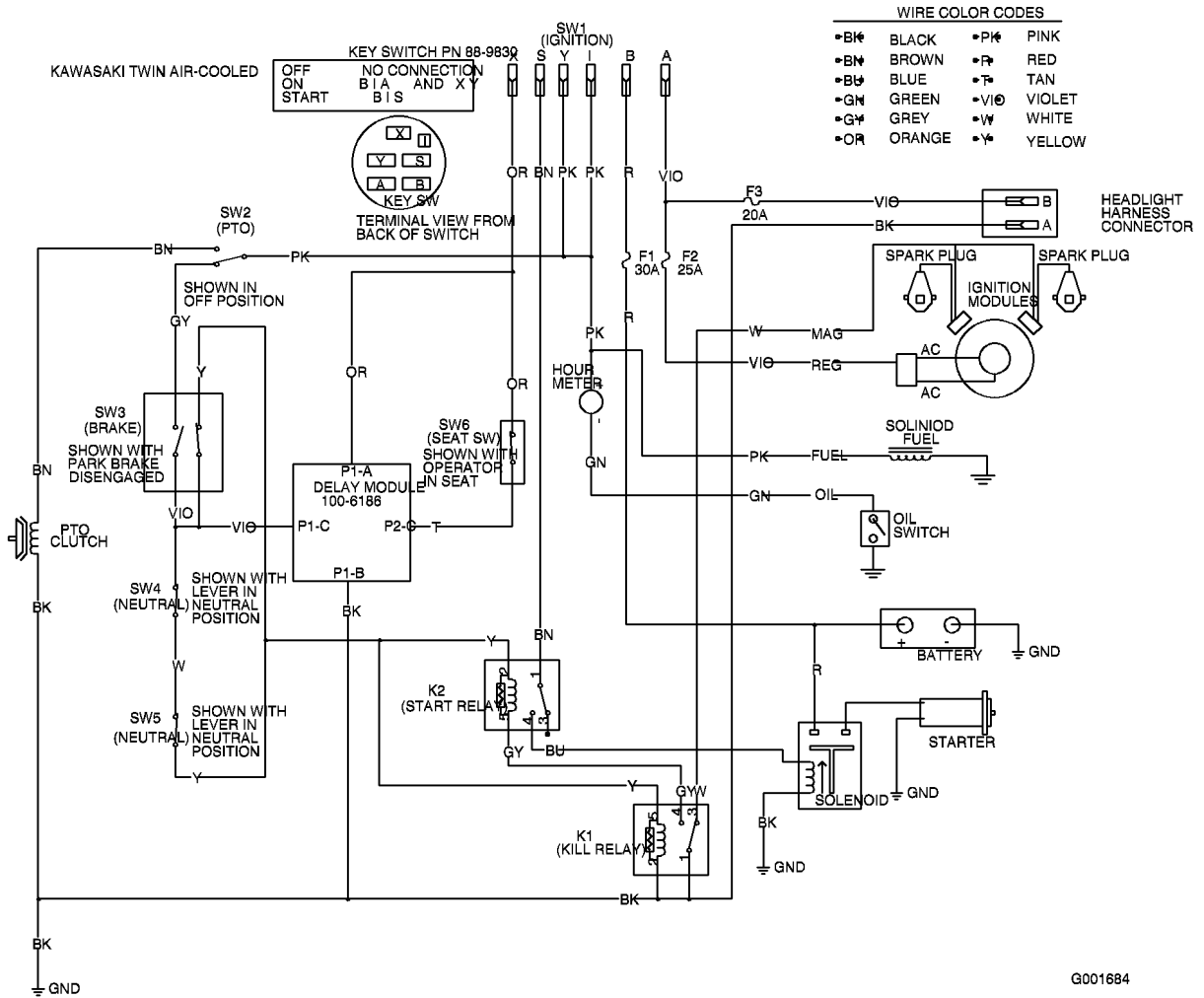

**Wire Diagram (Rev. A)**

G001684









## Evaporative Emission Control Warranty Statement

California Evaporative Emission Control Warranty Statement  
Your Warranty Rights and Obligations

### Introduction

The California Air Resources Board and The Toro® Company are pleased to explain the evaporative emission control system's warranty on your 2006 model year equipment. In California, new equipment that use small off-road engines must be designed, built, and equipped to meet the State's stringent anti-smog standards. The Toro® Company must warrant the evaporative emission control system on your equipment for two years provided there has been no abuse, neglect or improper maintenance of your equipment. Your evaporative emission control system may include parts such as: fuel lines, fuel line fittings, and clamps.

### Manufacturer's Warranty Coverage:

This evaporative emission control system is warranted for two years. If any evaporative emission-related part on your equipment is defective, the part will be repaired or replaced by The Toro® Company.

### Owner's Warranty Responsibilities:

- As the equipment owner, you are responsible for performance of the required maintenance listed in your Operator's Manual. The Toro® Company recommends that you retain all receipts covering maintenance on your equipment, but The Toro® Company cannot deny warranty solely for the lack of receipts.
- As the equipment owner, you should however be aware that The Toro® Company may deny you warranty coverage if your emission warranty parts have failed due to abuse, neglect, or improper maintenance or unapproved modifications.
- You are responsible for presenting your equipment to an Authorized Service Dealer as soon as the problem exists. The warranty repairs should be completed in a reasonable amount of time, not to exceed 30 days. If you have a question regarding your warranty coverage, you should contact The Toro® Company at 1-952-948-4027 or call us toll free at the number listed in your Toro Warranty statement.

### Defects Warranty Requirements:

1. The warranty period begins on the date the engine or equipment is delivered to an ultimate purchaser.
2. General Evaporative Emissions Warranty Coverage. The emission warranty parts must be warranted to the ultimate purchaser and any subsequent owner that the evaporative emission control system when installed was:
  - A. Designed, built, and equipped so as to conform with all applicable regulations; and
  - B. Free from defects in materials and workmanship that causes the failure of a warranted part for a period of two years.
3. The warranty on evaporative emissions-related parts will be interpreted as follows:
  - A. Any warranted part that is not scheduled for replacement as required maintenance in the written instructions must be warranted for the warranty period of two years. If any such part fails during the period of warranty coverage, it must be repaired or replaced by The Toro® Company. Any such part repaired or replaced under the warranty must be warranted for a time not less than the remaining warranty period.
  - B. Any warranted part that is scheduled only for regular inspection in the written instructions must be warranted for the warranty period of two years. A statement in such written instructions to the effect of "repair or replace as necessary" will not reduce the period of warranty coverage. Any such part repaired or replaced under warranty must be warranted for a time not less than the remaining warranty period.
  - C. Any warranted part that is scheduled for replacement as required maintenance in the written instructions must be warranted for the period of time prior to the first scheduled replacement point for that part. If the part fails prior to the first scheduled replacement, the part must be repaired or replaced by The Toro® Company. Any such part repaired or replaced under warranty must be warranted for a time not less than the remainder of the period prior to the first scheduled replacement point for the part.
  - D. Repair or replacement of any warranted part under the warranty provisions of this article must be performed at no charge to the owner at an Authorized Service Dealer.
  - E. Notwithstanding the provisions of subsection (D) above, warranty services or repairs must be provided at an Authorized Service Dealer.
  - F. The owner must not be charged for diagnostic labor that leads to the determination that a warranted part is in fact defective, provided that such diagnostic work is performed at an Authorized Service Dealer.
  - G. Throughout the evaporative emission control system's two year warranty period, The Toro® Company must maintain a supply of warranted parts sufficient to meet the expected demand for such parts.
  - H. Manufacturer approved replacement parts must be used in the performance of any warranty maintenance or repairs and must be provided without charge to the owner. Such use will not reduce the warranty obligations of The Toro® Company.
  - I. The use of any add-on or modified parts will be grounds for disallowing a warranty claim made in accordance with this article. The Toro® Company will not be liable under this Article to warrant failures of warranted parts caused by the use of an add-on or modified part.
  - J. The Toro® Company shall provide any documents that describe the warranty procedures or policies within five working days of request by the Air Resources Board.

### Emission Warranty Parts List:

The following lists includes the parts covered under this warranty:

- Fuel Lines
- Fuel Line Fittings
- Clamps



LCE

# The Toro Total Coverage Guarantee

A Limited Warranty

## Conditions and Products Covered

The Toro® Company and its affiliate, Toro Warranty Company, pursuant to an agreement between them, jointly promise to repair the listed Toro Products if defective in materials or workmanship.

This warranty applies to:

- ProLine Mid-Size Walk Power Mowers and Accessories
- Z Master Mid-Mount ZRTs and Accessories
- Z Master Outfront ZRTs and Accessories
- Groundsmaster 120 OFRs and Accessories

The following time periods apply from the date of purchase:

Components	Warranty Period
Engines	2 years
Hydraulic Systems	2 years
Traction Unit Frame	2 years
Carrier Frame	2 years
Deck Shells	2 years
Deck Spindles	3 years Parts 2 years Labor
Z500 Series Clutches	2 years
Remaining Components	1 year

This warranty includes the cost of parts and labor, but you must pay transportation costs.

Some engines used on Toro LCE Products are warranted by the engine manufacturer.

## Instructions for Obtaining Warranty Service

If you think that your Toro Product contains a defect in materials or workmanship, follow this procedure:

1. Contact any Toro Authorized or Master Service Dealer to arrange service at their dealership. To locate a dealer convenient to you, access our website at [www.Toro.com](http://www.Toro.com). You may also call our Toro Customer Care Department toll free at 888-577-7466 (U.S. customers) or 877-484-9255 (Canada customers).
2. Bring the product and your proof of purchase (sales receipt) to the Service Dealer.

If for any reason you are dissatisfied with the Service Dealer's analysis or with the assistance provided, contact us at:

## Owner Responsibilities

You must maintain your Toro Product by following the maintenance procedures described in the operator's manual. Such routine maintenance, whether performed by a dealer or by you, is at your expense.

## Countries Other than the United States or Canada

Customers who have purchased Toro products exported from the United States or Canada should contact their Toro Distributor (Dealer) to obtain guarantee policies for your country, province, or state. If for any reason you are dissatisfied with your Distributor's service or have difficulty obtaining guarantee information, contact the Toro importer. If all other remedies fail, you may contact us at Toro Warranty Company.

## Items and Conditions Not Covered

There is no other express warranty except for special emission system coverage on some products. This express warranty does not cover the following:

- Cost of regular maintenance service or parts, such as filters, fuel, lubricants, tune-up parts, blade sharpening, brake and clutch adjustments.
- Any product or part which has been altered or misused or required replacement or repair due to normal wear, accidents, or lack of proper maintenance.
- Repairs necessary due to improper fuel, contaminants in the fuel system, or failure to properly prepare the fuel system prior to any period of non-use over three months.
- Pickup and delivery charges.

All repairs covered by this warranty must be performed by an Authorized Toro Service Dealer using Toro approved replacement parts.

## General Conditions

Repair by an Authorized Toro Service Dealer is your sole remedy under this warranty.

Neither The Toro® Company nor Toro Warranty Company is liable for indirect, incidental or consequential damages in connection with the use of the Toro Products covered by this warranty, including any cost or expense of providing substitute equipment or service during reasonable periods of malfunction or non-use pending completion of repairs under this warranty.

Some states do not allow exclusions of incidental or consequential damages, or limitations on how long an implied warranty lasts, so the above exclusions and limitations may not apply to you.

All implied warranties of merchantability (that the product is fit for ordinary use) and fitness for use (that the product is fit for a particular purpose) are limited to the duration of the express warranty.

This warranty gives you specific legal rights, and you may also have other rights which vary from state to state.

LCB Customer Service Department  
 Toro Warranty Company  
 8111 Lyndale Avenue South  
 Bloomington, MN 55420-1196  
 888-577-7466 (U.S. customers)  
 877-484-9255 (Canada customers)