



**Count on it.**

**Operator's Manual**

**Z500 Z Master, With 52in or  
60in 7-Gauge Side Discharge  
Mower**

**Model No. 74248—Serial No. 260000001 and Up**

**Model No. 74249—Serial No. 260000001 and Up**

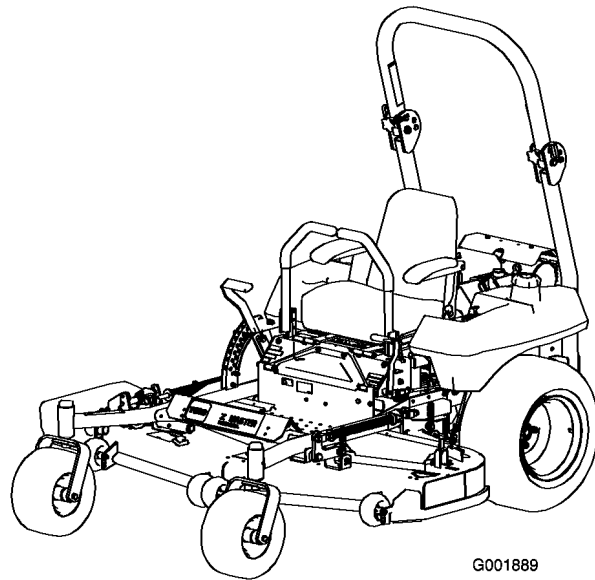

G001889

## Warning

### CALIFORNIA Proposition 65 Warning

The engine exhaust from this product contains chemicals known to the State of California to cause cancer, birth defects, or other reproductive harm.

**Important:** This engine is not equipped with a spark arrester muffler. It is a violation of California Public Resource Code Section 4442 to use or operate the engine on any forest-covered, brush-covered, or grass-covered land. Other states or federal areas may have similar laws.

This spark ignition system complies with Canadian ICES-002

The enclosed Engine Owner's Manual is supplied for information regarding the US Environmental Protection Agency (EPA) and the California Emission Control Regulation of emission systems, maintenance, and warranty. Replacements may be ordered through the engine manufacturer.

## Introduction

Read this information carefully to learn how to operate and maintain your product properly and to avoid injury and product damage. You are responsible for operating the product properly and safely.

You may contact Toro directly at [www.Toro.com](http://www.Toro.com) for product and accessory information, help finding a dealer, or to register your product.

Whenever you need service, genuine Toro parts, or additional information, contact an Authorized Service Dealer or Toro Customer Service and have the model and serial numbers of your product ready. Figure 1 identifies the location of the model and serial numbers on the product. Write the numbers in the space provided.



Figure 1

1. Model and serial number location

Model No. _____
Serial No. _____

This manual identifies potential hazards and has safety messages identified by the safety alert symbol (Figure 2), which signals a hazard that may cause serious injury or death if you do not follow the recommended precautions.



Figure 2

1. Safety alert symbol

This manual uses 2 other words to highlight information. **Important** calls attention to special mechanical information and **Note** emphasizes general information worthy of special attention.

## Contents

Introduction .....	2
Safety .....	4
Safe Operating Practices .....	4
Slope Chart .....	7
Safety and Instructional Decals .....	8
Product Overview .....	14
Controls .....	14
Operation.....	15
Adding Fuel .....	15
Checking the Engine Oil Level .....	16

Using the Rollover Protection System (ROPS).....	16	Replacing the Mower Belt .....	39
Think Safety First .....	17	Replacing the Pump Drive Belt .....	40
Operating the Parking Brake .....	18	Controls System Maintenance.....	41
Starting and Stopping the Engine .....	18	Adjusting the Control Handle Neutral Position .....	41
Operating the Power Take Off (PTO) .....	20	Mercury Tilt Switch .....	42
The Safety Interlock System.....	20	Hydraulic System Maintenance .....	42
Driving Forward or Backward .....	21	Checking the Hydraulic Fluid .....	42
Stopping the Machine .....	22	Replacing the Hydraulic Filter and Oil.....	43
Adjusting the Height-of-Cut .....	22	Bleeding the Hydraulic System .....	44
Adjusting the Anti-Scalp Rollers.....	22	Checking the Hydraulic Hoses .....	44
Positioning the Seat .....	23	Setting the Hydraulic Pump Neutral Position .....	45
Unlatching the Seat.....	24	Mower Deck Maintenance .....	47
Pushing the Machine by Hand.....	24	Leveling the Mower at Three Positions .....	47
Using the Side Discharge .....	24	Servicing the Cutting Blades.....	49
Breaking In a New Machine .....	25	Replacing the Grass Deflector.....	51
Transporting Machines .....	25	Cleaning .....	52
Loading Machines .....	25	Cleaning Under the Mower .....	52
Operating Tips .....	26	Waste Disposal .....	52
Maintenance.....	28	Storage.....	53
Recommended Maintenance Schedule(s) .....	28	Troubleshooting.....	54
Lubrication.....	28	Schematics .....	57
Greasing and Lubrication.....	28		
Engine Maintenance.....	30		
Servicing the Air Cleaner .....	30		
Servicing the Engine Oil .....	31		
Servicing the Spark Plug .....	32		
Fuel System Maintenance .....	33		
Replacing the Fuel Filter .....	33		
Draining the Fuel Tank .....	34		
Electrical System Maintenance.....	34		
Servicing the Battery.....	34		
Servicing the Fuses .....	36		
Drive System Maintenance.....	37		
Adjusting the Tracking.....	37		
Checking the Tire Pressure.....	37		
Checking the Wheel Hub Slotted Nut .....	37		
Adjusting the Caster Pivot Bearing.....	38		
Cooling System Maintenance .....	38		
Cleaning the Engine Screen and the Oil Cooler .....	38		
Cleaning the Engine Fins .....	39		
Brake Maintenance .....	39		
Adjusting the Parking Brake .....	39		
Belt Maintenance.....	39		

# Safety

Improper use or maintenance by the operator or owner can result in injury. To reduce the potential for injury, comply with these safety instructions and always pay attention to the safety alert symbol, which means **CAUTION, WARNING, or DANGER**-“personal safety instruction.” Failure to comply with the instruction may result in personal injury or death.

This product is capable of amputating hands and feet and throwing objects. Always follow all safety instructions to avoid serious injury or death.

This product is designed for cutting and recycling grass or, when equipped with a grass bagger, for catching cut grass. Any use for purposes other than these could prove dangerous to user and bystanders.

## Safe Operating Practices

The following instructions are from ANSI standard B71.4-2004.

### Training

- Read the Operator’s Manual and other training material. If the operator(s) or mechanic(s) can not read English it is the owner’s responsibility to explain this material to them.
- Become familiar with the safe operation of the equipment, operator controls, and safety signs.
- All operators and mechanics should be trained. The owner is responsible for training the users.
- Never let children or untrained people operate or service the equipment. Local regulations may restrict the age of the operator.
- The owner/user can prevent and is responsible for accidents or injuries occurring to himself or herself, other people or property.

### Preparation

- Evaluate the terrain to determine what accessories and attachments are needed to properly and safely perform the job. Only use accessories and attachments approved by the manufacturer.
- Wear appropriate clothing including hard hat, safety glasses and hearing protection. Long

hair, loose clothing or jewelry may get tangled in moving parts.

- Inspect the area where the equipment is to be used and remove all objects such as rocks, toys and wire which can be thrown by the machine.
- Use extra care when handling gasoline and other fuels. They are flammable and vapors are explosive.
  - Use only an approved container
  - Never refuel or drain the machine indoors.
  - Never remove gas cap or add fuel with engine running. Allow engine to cool before refueling. Do not smoke.
- Check that operator’s presence controls, safety switches and shields are attached and functioning properly. Do not operate unless they are functioning properly.

### Operation

- Never run an engine in an enclosed area.
- Only operate in good light, keeping away from holes and hidden hazards.
- Be sure all drives are in neutral and parking brake is engaged before starting engine. Start the engine only from the operator’s position. Use seat belts.
- Never raise mower with the blades running.
- Never operate without the PTO shield, or other guards securely in place. Be sure all interlocks are attached, adjusted properly, and functioning properly.
- Never operate with the discharge deflector raised, removed or altered, unless using a grass catcher.
- Do not change the engine governor setting or overspeed the engine.
- Stop on level ground, lower implements, disengage drives, engage parking brake, shut off engine before leaving the operator’s position for any reason including emptying the catchers or unclogging the chute.
- Stop equipment and inspect blades after striking objects or if an abnormal vibration occurs. Make necessary repairs before resuming operations.

- Keep hands and feet away from the cutting units.
- Never carry passengers and keep pets and bystanders away.
- Be alert, slow down and use caution when making turns. Look behind and to the side before changing directions.
- Slow down and use caution when crossing roads and sidewalks. Stop blades if not mowing.
- Be aware of the mower discharge direction and do not point it at anyone.
- Do not operate the mower under the influence of alcohol or drugs.
- Use extreme care when loading or unloading the machine into a trailer or truck.
- Use care when approaching blind corners, shrubs, trees, or other objects that may obscure vision.
- Always avoid sudden starting or stopping on a slope. If tires lose traction, disengage the blades and proceed slowly off the slope.
- Follow the manufacturer's recommendations for wheel weights or counterweights to improve stability.
- Use extreme care with grass catchers or other attachments. These can change the stability of the machine and cause loss of control.

### **Using the Rollover Protection System (ROPS)**

### **Slope Operation**

- Do not mow slopes greater than 15 degrees.
- Do not mow near drop-offs, ditches, steep banks or water. Wheels dropping over edges can cause rollovers, which may result in serious injury, death or drowning.
- Do not mow slopes when grass is wet. Slippery conditions reduce traction and could cause sliding and loss of control.
- Do not make sudden turns or rapid speed changes.
- Use a walk behind mower and/or a hand trimmer near drop-offs, ditches, steep banks or water.
- Reduce speed and use extreme caution on slopes.
- Remove or mark obstacles such as rocks, tree limbs, etc. from the mowing area. Tall grass can hide obstacles.
- Watch for ditches, holes, rocks, dips, and rises that change the operating angle, as rough terrain could overturn the machine.
- Avoid sudden starts when mowing uphill because the mower may tip backwards.
- Be aware that loss of traction may occur going downhill. Weight transfer to the front wheels may cause drive wheels to slip and cause loss of braking and steering.
- Keep the roll bar in the raised and locked position and use the seat belt when operating the machine.
- Be certain that the seat belt can be released quickly in the event of an emergency.
- Be aware there is no rollover protection when the roll bar is down.
- Check the area to be mowed and never fold the ROPS in areas where there are slopes, drop offs or water.
- Lower the rollbar only when absolutely necessary. Do not wear the seat belt with the roll bar folded down.
- Check carefully for overhead clearances (i.e. branches, doorways, electrical wires) before driving under any objects and do not contact them.

### **Maintenance and storage**

- Disengage drives, lower implement, set parking brake, stop engine and remove key or disconnect spark plug wire. Wait for all movement to stop before adjusting, cleaning or repairing.
- Clean grass and debris from cutting units, drives, mufflers, and engine to help prevent fires. Clean up oil or fuel spillage.
- Let engine cool before storing and do not store near flame.
- Shut off fuel while storing or transporting. Do not store fuel near flames or drain indoors.
- Park machine on level ground. Never allow untrained personnel to service machine.
- Use jack stands to support components when required.

- Carefully release pressure from components with stored energy.
- Disconnect battery or remove spark plug wire before making any repairs. Disconnect the negative terminal first and the positive last. Reconnect positive first and negative last.
- Use care when checking blades. Wrap the blade(s) or wear gloves, and use caution when servicing them. Only replace blades. Never straighten or weld them.
- Keep hands and feet away from moving parts. If possible, do not make adjustments with the engine running.
- Charge batteries in an open well ventilated area, away from spark and flames. Unplug charger before connecting or disconnecting from battery. Wear protective clothing and use insulated tools.
- Keep all parts in good working condition and all hardware tightened. Replace all worn or damaged decals.
- Use only Toro approved attachments. Warranty may be voided if used with unapproved attachments.

# Slope Chart

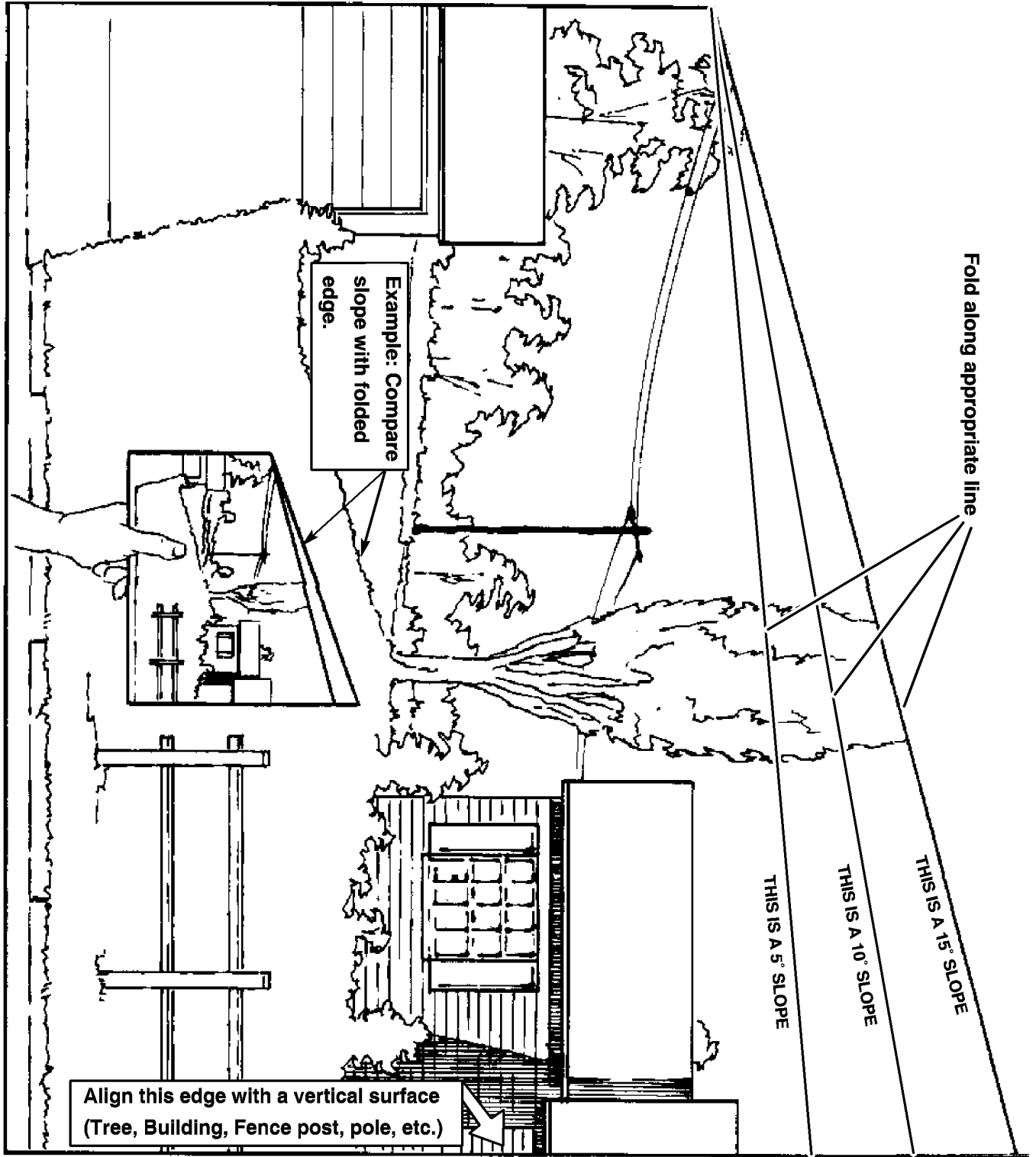

# Safety and Instructional Decals



Safety decals and instructions are easily visible to the operator and are located near any area of potential danger. Replace any decal that is damaged or lost.



**106-9969**

**⚠ WARNING**

- Operating on wet grass or steep slopes can cause sliding and loss of control.
- Wheels dropping over edges can cause rollovers, which may result in serious injury, death or drowning.
- To avoid loss of control and possibility of rollover:
  - Do NOT operate near drop-offs or near water.
  - Do NOT operate on slopes greater than 15°.
  - Reduce speed and use extreme caution on slopes.
  - Avoid sudden turns or rapid speed changes.
- There is no rollover protection when the roll bar is down.
- Always keep roll bar in the raised and locked position and use seat belt.
- Read and follow rollover protection instructions and warning.

107-2112

**107-2112**

**ANSI B71.4 - 2004**  
**CE - EN836:1997**

108-5278

**108-5278**

1. Read the *Operator's Manual*.

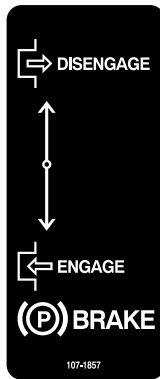

**107-1857**

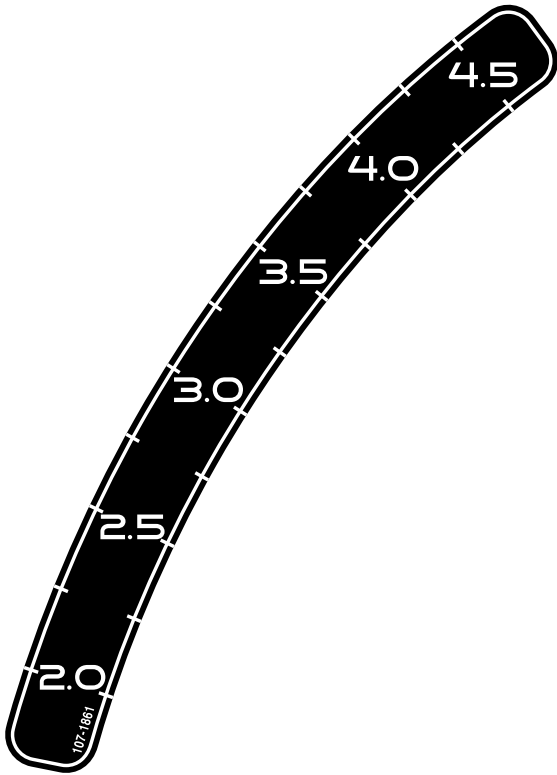

**107-1861**

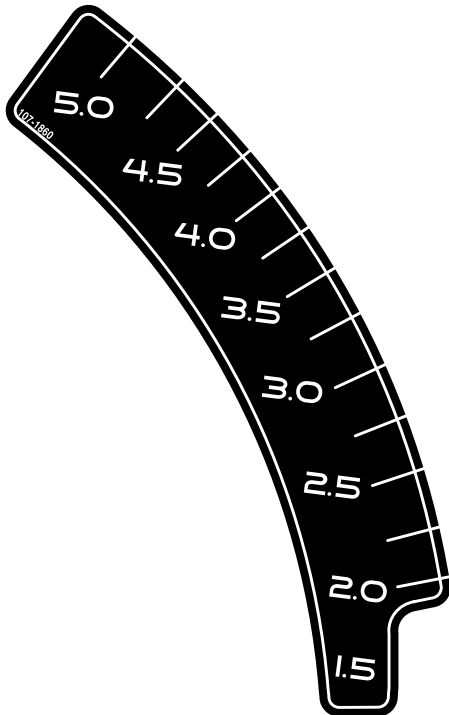

**107-1860**



**98-4387**

1. Warning—wear hearing protection.



**107-1864**



**1-523552**



**107-2102**

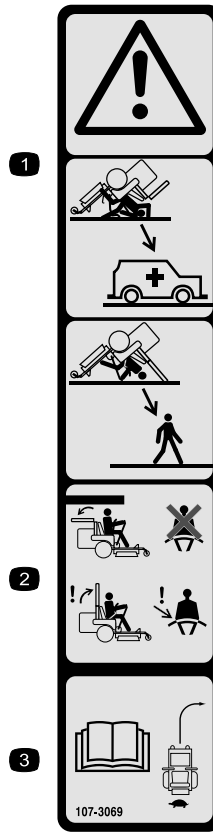

**107-3069**

1. Warning—there is no rollover protection when the roll bar is down.
2. To avoid injury or death from a rollover accident, keep the roll bar in the raised and locked position and wear the seat belt. Lower the roll bar only when absolutely necessary; do not wear the seat belt when the roll bar is down.
3. Read the *Operator's Manual*; drive slowly and carefully.



**54-9220**



66-1340



98-5954



1-403005



68-8340



58-6520

1. Grease



104-8569



- ————— 1.5" / 38mm
- ————— 2.0" / 51mm
- ————— 2.5" / 63mm
- ————— 3.0" / 76mm

105-7798

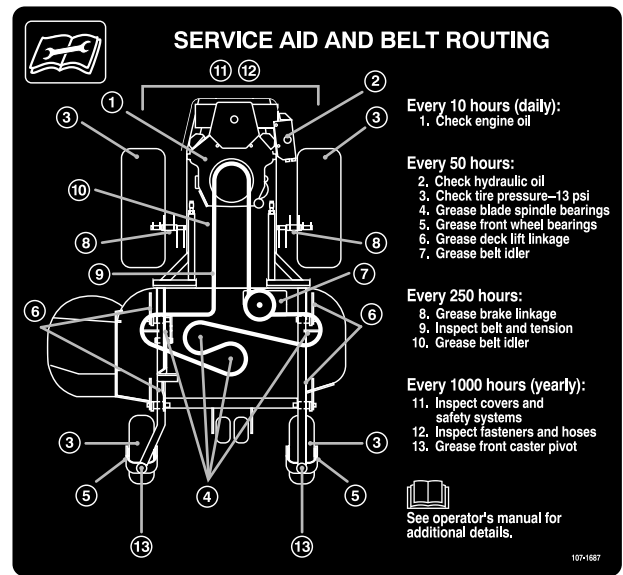

107-1687



107-1613

**IMPORTANT:**  
BEFORE STARTING ENGINE  
CLEAN GRASS FROM PUMP  
DRIVE BELT COMPARTMENT.  
CHECK MORE OFTEN IN DRY  
CONDITIONS. 1-633462

**1-633462**

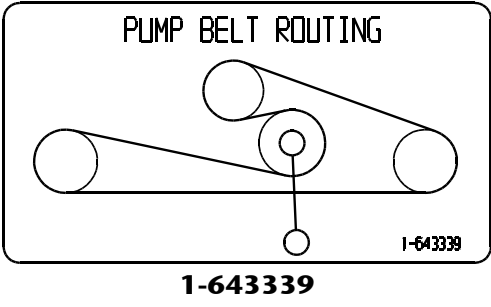

**WARNING**

ROTATING MECHANICAL DEVICES  
CAN CAUSE SERIOUS INJURY!

- DO NOT operate without guards in place
- Stop engine before opening cover

103-5881

**103-5881**

**IMPORTANT!**

**BATTERY CHARGING INSTRUCTIONS**

Prior to first use of the battery,  
charge for a minimum of  
one hour at 6-10 amps.

107-9309

**107-9309**

1. Warning—read the *Operator's Manual* for information on charging the battery; contains lead; do not discard.
2. Read the *Operator's Manual*.



**Battery Symbols**

Some or all of these symbols are on your battery

- |  |  |
|--|--|
| 1. Explosion hazard                    | 6. Keep bystanders a safe distance from the battery.                           |
| 2. No fire, open flame, or smoking.    | 7. Wear eye protection; explosive gases can cause blindness and other injuries |
| 3. Caustic liquid/chemical burn hazard | 8. Battery acid can cause blindness or severe burns.                           |
| 4. Wear eye protection                 | 9. Flush eyes immediately with water and get medical help fast.                |
| 5. Read the <i>Operator's Manual</i> . | 10. Contains lead; do not discard.   |

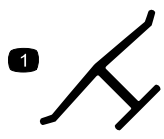

**Manufacturer's Mark**



1. Indicates the blade is identified as a part from the original machine manufacturer.

**⚠ DANGER**

- Pick up objects that could be thrown by the blades.
- Never mow when bystanders are in the area.
- Never carry passengers.
- Look behind and to the side before changing directions.
- Stop the engine and remove key before adjusting, servicing or cleaning machine and attachments.

Before leaving the operator's position:

- Stop the engine and disengage the blade.
- Move the levers out to the neutral lock position.
- Set the parking brake.
- Avoid blades unless engine and blades are stopped.

106-7492

For replacement manual, send model & serial number to: The Toro Co., 8111 Lyndale Ave. S., Bloomington, MN 55420.

**IMPORTANT:** Before starting engine clean grass from pump drive belt compartment. Check more often in dry conditions.

**⚠ WARNING**

To avoid serious injury or death:

- Read and understand the operator's manual before using this machine.
- Do not operate unless trained to safely use this machine.
- Do not operate under the influence of alcohol or drugs.
- Do not operate without shields, guards, and safety devices in place and working.
- Check the function of all safety interlocks daily.
- Do not defeat interlocks.
- Hearing protection is recommended.

106-9989

MOTION CONTROL

1 2 3 4

1 2 3 4

**⚠ WARNING** Battery contains sulfuric acid. Avoid contact and always shield eyes, face, skin and clothing from battery. Cigarettes, flames or sparks could cause battery to explode. Do not charge or use booster cables or adjust post connections without proper training. In event of an accident flush with water immediately. Keep out of reach of children.

Drive Wheel Release

107-8076

1. Fast

2. Slow

3. Neutral

4. Reverse

# Product Overview

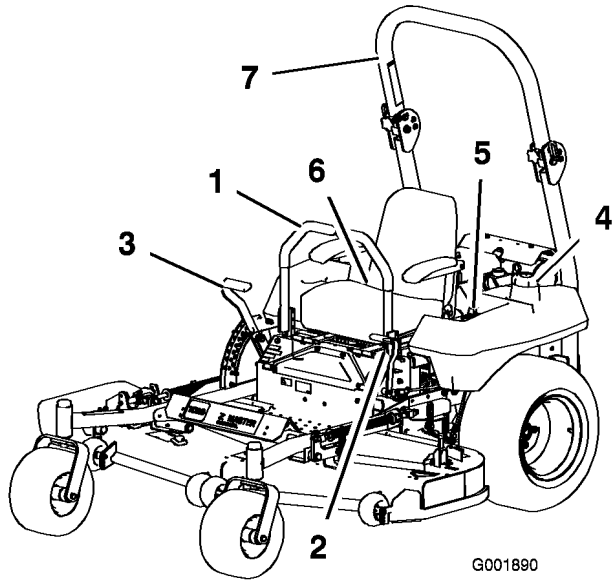
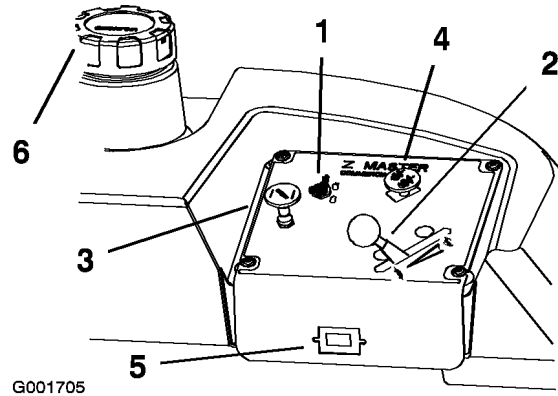

**Figure 3**

- |                          |              |
|--------------------------|--------------|
| 1. Motion control lever  | 5. Controls  |
| 2. Parking brake lever   | 6. Seat belt |
| 3. Height-of-cut lever   | 7. Roll bar  |
| 4. Fuel cap (both sides) |              |

# Controls

Become familiar with all the controls before you start the engine and operate the machine (Figure 3 and Figure 4).



**Figure 4**

- |                    |                         |
|--------------------|-------------------------|
| 1. Ignition switch | 4. Power take off (PTO) |
| 2. Throttle        | 5. Hour meter           |
| 3. Choke           | 6. Gas cap              |

## Hour Meter

The hour meter records the number of hours the engine has operated. It operates when the engine is running. Use these times for scheduling regular maintenance (Figure 4).

# Operation

**Note:** Determine the left and right sides of the machine from the normal operating position.

## Adding Fuel

Use **Unleaded** Regular Gasoline suitable for automotive use (85 pump octane minimum). Leaded regular gasoline may be used if unleaded regular is not available.

**Important:** Never use methanol, gasoline containing methanol, or gasohol containing more than 10% ethanol because the fuel system could be damaged. Do not mix oil with gasoline.



In certain conditions, gasoline is extremely flammable and highly explosive. A fire or explosion from gasoline can burn you and others and can damage property.

- Fill the fuel tank outdoors, in an open area, when the engine is cold. Wipe up any gasoline that spills.
- Never fill the fuel tank inside an enclosed trailer.
- Do not fill the fuel tank completely full. Add gasoline to the fuel tank until the level is 1/4 to 1/2 inch (6 to 13 mm) below the bottom of the filler neck. This empty space in the tank allows gasoline to expand.
- Never smoke when handling gasoline, and stay away from an open flame or where gasoline fumes may be ignited by a spark.
- Store gasoline in an approved container and keep it out of the reach of children. Never buy more than a 30-day supply of gasoline.
- Do not operate without entire exhaust system in place and in proper working condition.



In certain conditions during fueling, static electricity can be released causing a spark which can ignite the gasoline vapors. A fire or explosion from gasoline can burn you and others and can damage property.

- Always place gasoline containers on the ground away from your vehicle before filling.
- Do not fill gasoline containers inside a vehicle or on a truck or trailer bed because interior carpets or plastic truck bed liners may insulate the container and slow the loss of any static charge.
- When practical, remove gas-powered equipment from the truck or trailer and refuel the equipment with its wheels on the ground.
- If this is not possible, then refuel such equipment on a truck or trailer from a portable container, rather than from a gasoline dispenser nozzle.
- If a gasoline dispenser nozzle must be used, keep the nozzle in contact with the rim of the fuel tank or container opening at all times until fueling is complete.



Gasoline is harmful or fatal if swallowed. Long-term exposure to vapors can cause serious injury and illness.

- Avoid prolonged breathing of vapors.
- Keep face away from nozzle and gas tank or conditioner opening.
- Keep gas away from eyes and skin.

## Using Stabilizer/Conditioner

Use a fuel stabilizer/conditioner in the machine to provide the following benefits:

- Keeps gasoline fresh during storage of 90 days or less. For longer storage it is recommended that the fuel tank be drained.

- Cleans the engine while it runs
- Eliminates gum-like varnish buildup in the fuel system, which causes hard starting

**Important:** Do not use fuel additives containing methanol or ethanol.

Add the correct amount of gas stabilizer/conditioner to the gas.

**Note:** A fuel stabilizer/conditioner is most effective when mixed with fresh gasoline. To minimize the chance of varnish deposits in the fuel system, use fuel stabilizer at all times.

### Filling the Fuel Tank

1. Shut the engine off and set the parking brake.
2. Clean around each fuel tank cap and remove the cap.
3. Add unleaded regular gasoline to both fuel tanks, until the level is 1/4 to 1/2 inch (6 mm to 13 mm) below the bottom of the filler neck.

This space in the tank allows gasoline to expand. Do not fill the fuel tanks completely full.

4. Install fuel tank caps securely.
5. Wipe up any gasoline that may have spilled.

### Checking the Engine Oil Level

Before you start the engine and use the machine, check the oil level in the engine crankcase; refer to Checking the Oil Level in Engine Maintenance, page 30

### Using the Rollover Protection System (ROPS)



To avoid injury or death from rollover: keep the roll bar in the raised locked position and use the seat belt.

Ensure that the rear part of the seat is secured with the seat latch.



There is no rollover protection when the roll bar is in the down position.

- Lower the roll bar only when absolutely necessary.
- Do not wear the seat belt when the roll bar is in the down position.
- Drive slowly and carefully.
- Raise the roll bar as soon as clearance permits.
- Check carefully for overhead clearances (i.e. branches, doorways, electrical wires) before driving under any objects and do not contact them.

**Important:** Lower the roll bar only when absolutely necessary.

1. To lower the roll bar, loosen the front knobs (Figure 7).
2. Remove the hairpin cotter pins and remove the two pins (Figure 6).
3. Lower the roll bar to the down position. There are two down positions. See Figure 5 for the positions.
4. Install the two pins and secure them with the hairpin cotter pins (Figure 6).

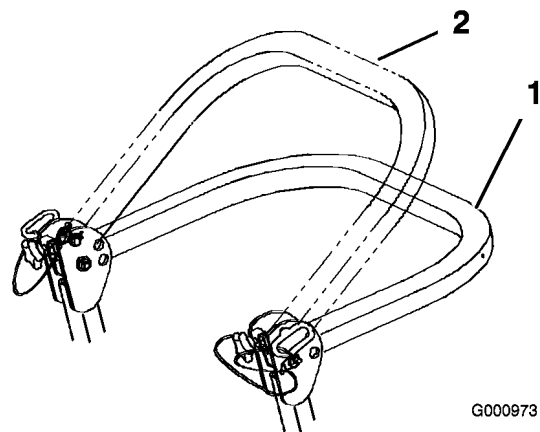

**Figure 5**

1. Full down position
2. Down position with bagger installed

**Important:** Ensure that the rear part of the seat is secured with the seat latch.

5. To raise the roll bar, remove the hairpin cotter pins and remove the two pins (Figure 6).
6. Raise the roll bar to the upright position and install the two pins and secure them with the hairpin cotter pins (Figure 6).

**Important:** Always use the seat belt with the roll bar in the raised position.

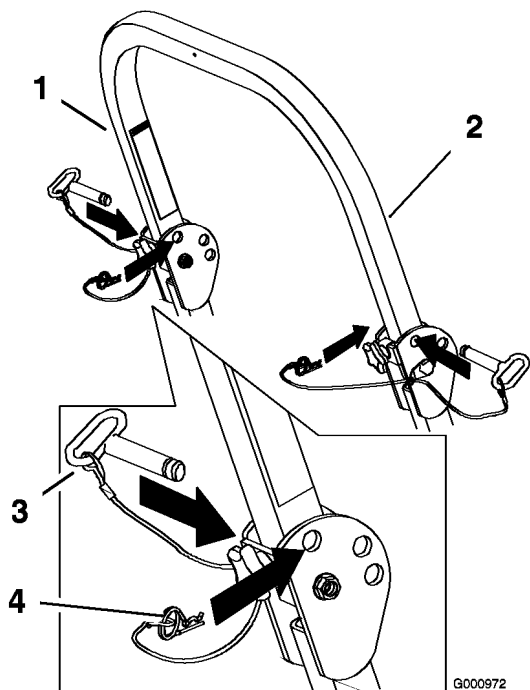

**Figure 6**

- |                    |                       |
|--------------------|-----------------------|
| 1. Roll bar        | 3. Pin                |
| 2. Raised position | 4. Hairpin cotter pin |

**Important:** Tighten the front knobs against the center roll bar ends (Figure 7).

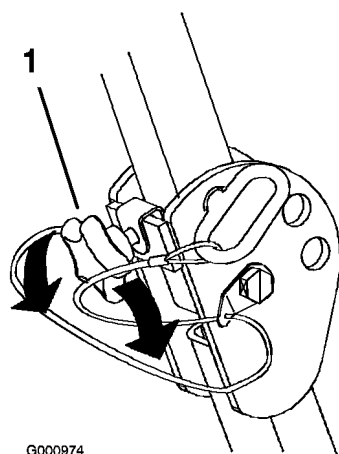

**Figure 7**

1. Front handle

## Think Safety First

Please read all safety instructions and symbols in the safety section. Knowing this information could help you or bystanders avoid injury.



Operating on wet grass or steep slopes can cause sliding and loss of control.

Wheels dropping over edges can cause rollovers, which may result in serious injury, death or drowning.

There is no rollover protection when the roll bar is down.

Always keep the roll bar in the raised and locked position and use the seat belt.

Read and follow the rollover protection instructions and warnings.

To avoid loss of control and possibility of rollover:

- Do not operate near drop-offs or near water.
- Do not operate on slopes greater than 15 degrees.
- Reduce speed and use extreme caution on slopes.
- Avoid sudden turns or rapid speed changes.

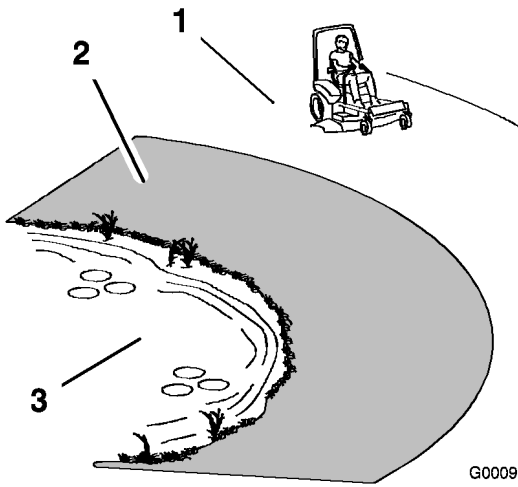

**Figure 8**

1. Safe Zone-use the Z Master here on slopes less than 15 degrees or flat areas.
2. Use walk behind mower and/or hand trimmer near drop-offs and water.
3. Water

**This machine produces sound levels in excess of 85 dBA at the operators ear and can cause hearing loss through extended periods of exposure.**

**Wear hearing protection when operating this machine.**

The use of protective equipment for eyes, ears, feet and head is recommended.

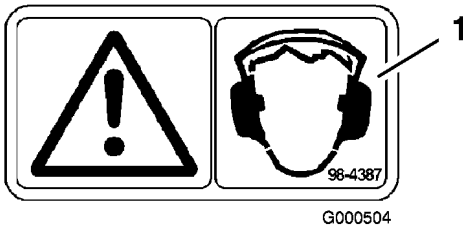

**Figure 9**

1. Warning— wear hearing protection

## Operating the Parking Brake

Always set the parking brake when you stop the machine or leave it unattended.

## Setting the Parking Brake

1. Move the motion control levers (Figure 16) out to the neutral lock position.
2. Pull up and back on the parking brake lever to set the parking brake (Figure 10). The parking brake lever should stay firmly in the engaged position.

**Parking brake may not hold machine parked on a slope and could cause personal injury or property damage.**

**Do not park on slopes unless wheels are chocked or blocked**

## Releasing the Parking Brake

Push forward and down on the parking brake lever to release the parking brake (Figure 10). The parking brake is disengaged and the lever will rest against the brake stop.

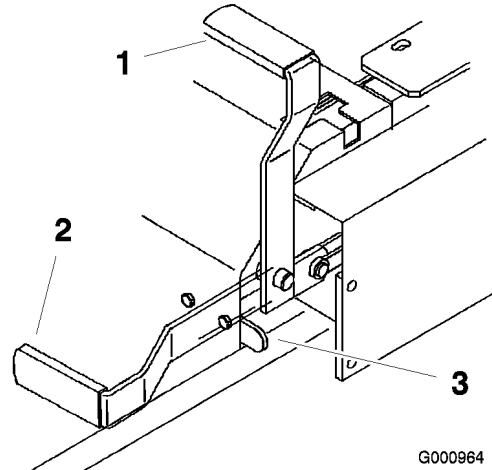

**Figure 10**

1. Parking brake-ON
2. Parking brake-OFF
3. Brake Stop

## Starting and Stopping the Engine

### Starting the Engine

1. Sit on the seat and move the motion controls to neutral locked position.
2. Set the parking brake; refer to Setting the Parking Brake.

3. Move the PTO (power take off) switch to the Off position (Figure 11).

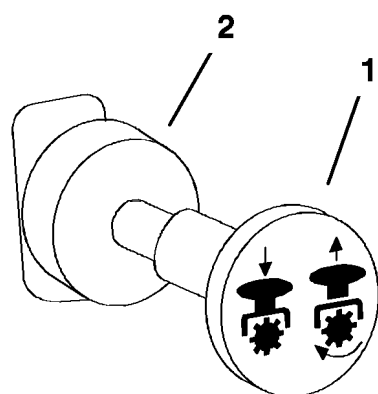
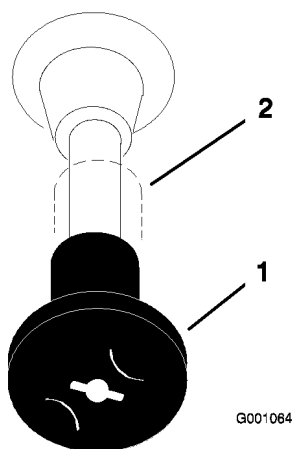

**Figure 11**

1. PTO—on
2. PTO—off

4. Move the choke control to the on position before starting a cold engine (Figure 12).

**Note:** A warm or hot engine may not require choking. After engine starts, move choke control to Run position.



**Figure 12**

1. Choke—on
2. Choke—off

5. Move the throttle control to the Fast position before starting a cold engine (Figure 13).

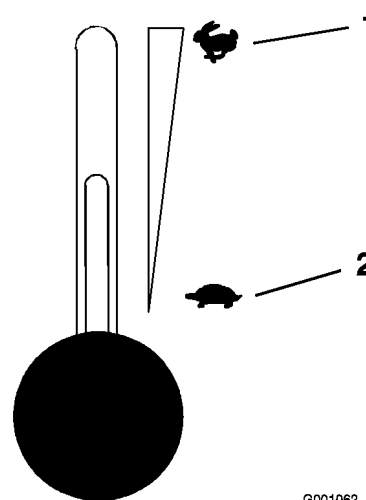
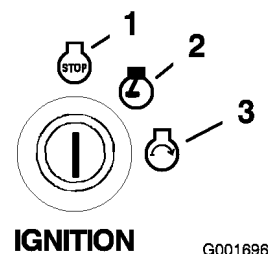

**Figure 13**

1. Throttle—fast
2. Throttle—slow

6. Turn the ignition key to Start (Figure 14). When the engine starts, release the key.

**Important:** Do not engage starter for more than 10 seconds at a time. If engine fails to start allow 30 second cool-down period between attempts. Failure to follow these instructions can burn out starter motor.



**IGNITION**

**Figure 14**

1. Off
2. Run
3. Start

7. After the engine starts, move the choke to off (Figure 12). If the engine stalls or hesitates, move the choke back to on for a few seconds, then move the throttle lever to desired setting. Repeat this as required.

### Stopping the Engine

1. Push the PTO to the off position (Figure 11).
2. Move the throttle lever midway between the slow and fast positions (Figure 13).
3. Let the engine idle for 60 seconds.

- Turn the ignition key to the off position and remove the key (Figure 14).
- Close the fuel shut off valve before transporting or storing the machine. Refer to Fuel System Maintenance, page 33.

**Important:** Make sure that the fuel shut off valve is closed before transporting or storing the machine, as fuel leakage may occur. Set the parking brake before transporting. Make sure to remove the key as the fuel pump may run and cause the battery to lose charge.



Children or bystanders may be injured if they move or attempt to operate the tractor while it is unattended.

Always remove the ignition key and set the parking brake when leaving the machine unattended, even if just for a few minutes.

## Operating the Power Take Off (PTO)

The power take off (PTO) switch starts and stops the mower blades and any powered attachments.

### Engaging the PTO

- If the engine is cold, allow the engine to warm up 5 to 10 minutes before engaging the PTO.
- While seated in the seat, release the pressure on the traction control levers and place in neutral.
- Place the throttle in the fast position.

**Note:** Engaging the PTO with the throttle at the half or less position will cause excessive wear to the drive belts.

- Pull out on the power take off (PTO) switch to engage it (Figure 15).

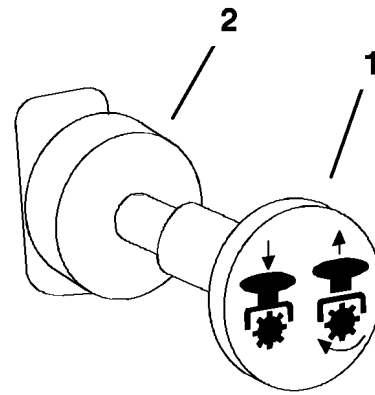

G000937

**Figure 15**

1. PTO-On

2. PTO-Off

## Disengaging the PTO

To disengage, push the PTO switch to the off position (Figure 15).

## The Safety Interlock System



If safety interlock switches are disconnected or damaged the machine could operate unexpectedly causing personal injury.

- Do not tamper with the interlock switches.
- Check the operation of the interlock switches daily and replace any damaged switches before operating the machine.

### Understanding the Safety Interlock System

The safety interlock system is designed to prevent the engine from starting unless:

- You are sitting on the seat.
- The parking brake is engaged.
- The power take off (PTO) is disengaged.
- The motion control levers are in the neutral locked position

The safety interlock system also is designed to stop the engine when the traction controls are moved from the locked position with the parking brake

engaged or if you rise from the seat when the PTO is engaged.

## Testing the Safety Interlock System

Test the safety interlock system before you use the machine each time. If the safety system does not operate as described below, have an Authorized Service Dealer repair the safety system immediately.

1. Sitting on the seat, engage the parking brake and move the PTO to on. Try starting the engine; the engine should not crank.
2. Sitting on the seat, engage the parking brake and move the PTO to off. Move either motion control lever (out of neutral locked position). Try starting the engine; the engine should not crank. Repeat for other control lever.
3. Sitting on the seat, engage the parking brake, move the PTO switch to off and move the motion control levers to neutral lock position. Now start the engine. While the engine is running, release the parking brake, engage the PTO and rise slightly from the seat; the engine should stop.
4. Sitting on the seat, engage the parking brake, move the PTO switch to off and move the motion control levers to neutral lock position. Now start the engine. While the engine is running, center either motion control and move (forward or reverse); the engine should stop. Repeat for other motion control.
5. Sitting on the seat, disengage the parking brake, move the PTO switch to off and move the motion control levers to neutral lock position. Try starting the engine; the engine should not crank.

## Driving Forward or Backward

The throttle control regulates the engine speed as measured in rpm (revolutions per minute). Place the throttle control in the fast position for best performance. Always operate in the full throttle position when mowing.



**Machine can spin very rapidly. Operator may lose control of machine and cause personal injury or damage to machine.**

- Use caution when making turns.
- Slow the machine down before making sharp turns.

## Driving Forward

1. Release the parking brake; refer to Releasing the Parking Brake.
2. Move the levers to the center, un-locked position.
3. To go forward, slowly push the motion control levers forward (Figure 16).

**Note:** The engine will kill if the traction control levers are moved with the parking brake engaged.

To go straight, apply equal pressure to both motion control levers (Figure 16).

To turn, move the motion control lever toward neutral in the direction you want to turn (Figure 16).

The farther you move the traction control levers in either direction, the faster the machine will move in that direction.

To stop, pull the motion control levers to the neutral position.

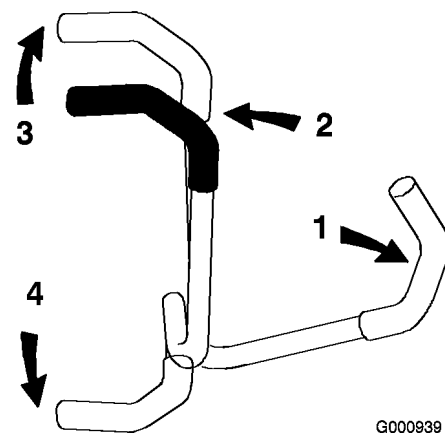

**Figure 16**

- |   |             |
|---|-------------|
| 1. Motion control lever-neutral lock position | 3. Forward  |
| 2. Center un-lock position                    | 4. Backward |

## Driving Backward

1. Move the levers to the center, un-locked position.
2. To go backward, slowly pull the motion control levers rearward (Figure 16).

To go straight, apply equal pressure to both motion control levers (Figure 16).

To turn, release pressure on the motion control lever toward the direction you want to turn (Figure 16).

To stop, push the motion control levers to the neutral position.

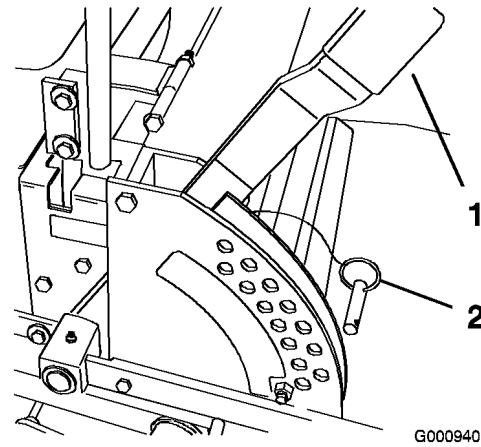

**Figure 17**

1. Height of cut lever      2. Clevis Pin

## Stopping the Machine

To stop the machine, move the traction control levers to neutral and move to locked position, disengage the power take off (PTO), and turn the ignition key to off.

Set the parking brake when you leave the machine; refer to Setting the Parking Brake. Remember to remove the key from the ignition switch.



**Children or bystanders may be injured if they move or attempt to operate the tractor while it is unattended.**

**Always remove the ignition key and set the parking brake when leaving the machine unattended, even if just for a few minutes.**

## Adjusting the Height-of-Cut

The height-of-cut is adjusted from 1-1/2 to 5 inch (38 to 127 mm) in 1/4 inch (6 mm) increments by relocating the clevis pin into different hole locations.

1. Raise the height-of-cut lever to the transport position (also the 5 inch (127 mm) cutting height position) (Figure 17).

2. To adjust, remove the clevis pin from the height-of-cut bracket (Figure 17).
3. Select a hole in the height-of-cut bracket corresponding to the height-of-cut desired and, insert the clevis pin (Figure 17).
4. Move the lever to the selected height.

## Adjusting the Anti-Scalp Rollers

Whenever you change the height-of-cut, it is recommended to adjust the height of the anti-scalp rollers.

### Adjusting the Outer Roller

1. Disengage the PTO, move the motion control levers to the neutral locked position, and set the parking brake.
2. Stop the engine, remove the key, and wait for all moving parts to stop before leaving the operating position.
3. After adjusting the height-of-cut, remove the flange nut, bushing, spacer, and bolt (Figure 18).

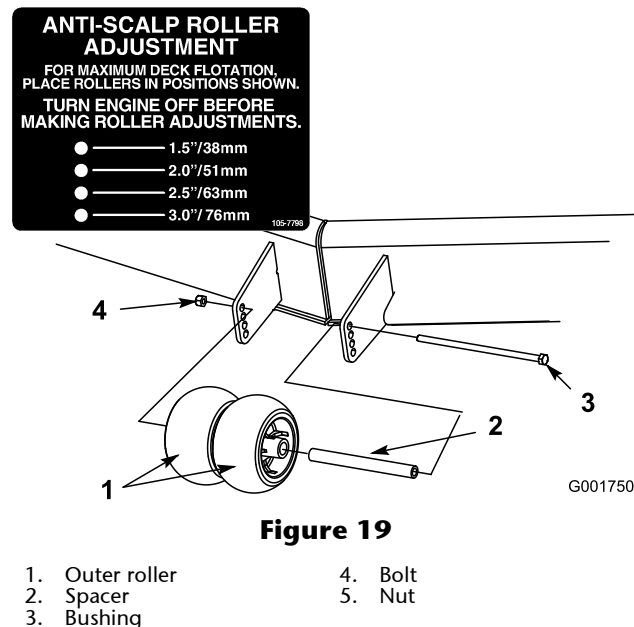
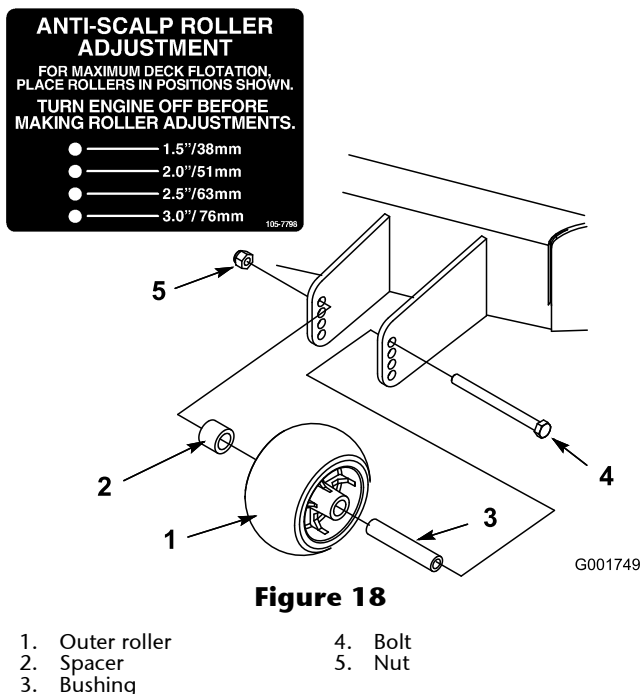

4. Select a hole so that the outer roller is positioned to the nearest corresponding height-of-cut desired (Figure 18).
5. Install the outer roller, bushing, spacer, bolt, and nut (Figure 18).
6. Torque the bolt to 40 to 45 ft-lb (54 to 61 N·m).

### Adjusting the Center Rollers

1. Disengage the PTO, move the motion control levers to the neutral locked position, and set the parking brake.
2. Stop the engine, remove the key, and wait for all moving parts to stop before leaving the operating position.
3. After adjusting the height-of-cut, remove the flange nut, bushing, and bolt (Figure 19).

4. Select a hole so that the center rollers are positioned to the nearest corresponding height-of-cut desired (Figure 19).
- Note:** Do not adjust the rollers to support the mower housing.
5. Install the center rollers, bushing, spacer, bolt, and nut (Figure 19).
  6. Torque the bolt to 40 to 45 ft-lb (54 to 61 N·m).

### Positioning the Seat

The seat can move forward and backward. Position the seat where you have the best control of the machine and are most comfortable.

**Important:** To adjust, move the lever sideways to unlock seat (Figure 20).

Slide the seat to the desired position and release lever to lock in position.

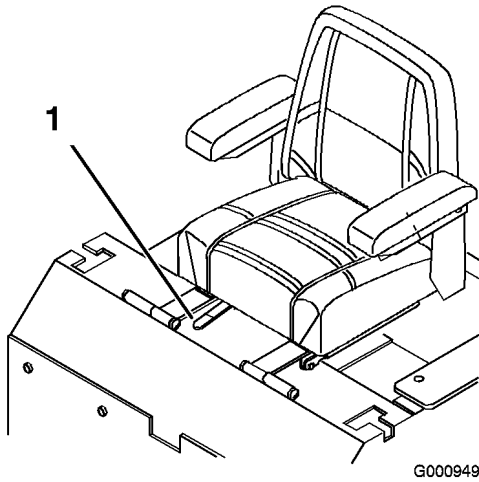
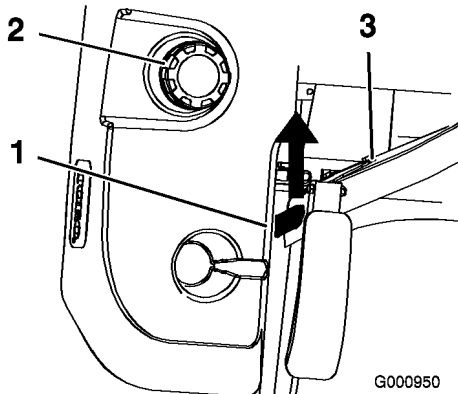

**Figure 20**

1. Adjustment lever

## Unlatching the Seat

Push the seat latch rearward to unlatch the seat. This will allow access to the machine under the seat (Figure 21).



**Figure 21**

1. Seat latch
2. Fuel cap
3. Seat

## Pushing the Machine by Hand

**Important:** Always push the machine by hand. Never tow the machine because hydraulic damage may occur.

### Pushing the Machine

1. Disengage the power take off (PTO) and turn the ignition key to off. Move the levers

to neutral locked position and apply parking brake. Remove the key.

2. Rotate the by-pass valves counterclockwise 1 turn to push. This allows hydraulic fluid to by-pass the pump enabling the wheels to turn (Figure 22).

**Important:** Do not rotate by-pass valves more than 1 turn. This prevents valves from coming out of the body and causing fluid to run out.

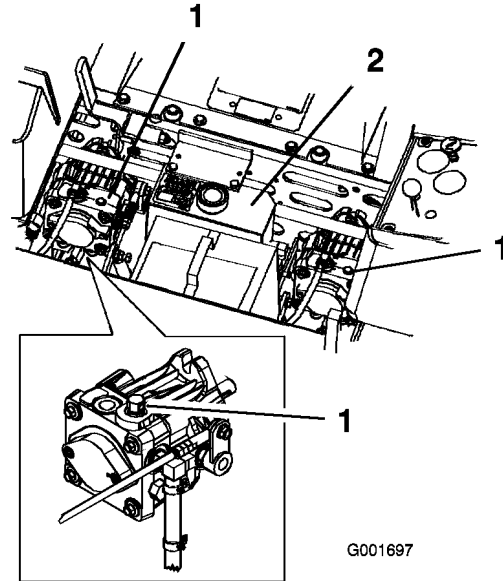

**Figure 22**

1. By-pass valve
2. Hydraulic tank

3. Disengage parking brake before pushing.

## Changing to Machine Operation

Rotate the by-pass valves clockwise 1 turn to operate machine (Figure 22).

**Note:** Do not over tighten the by-pass valves.

The machine will not drive unless by-pass valves are turned in.

## Using the Side Discharge

The mower has a hinged grass deflector that disperses clippings to the side and down toward the turf.



Without the grass deflector, discharge cover, or complete grass catcher assembly mounted in place, you and others are exposed to blade contact and thrown debris. Contact with rotating mower blade(s) and thrown debris will cause injury or death.

- Never remove the grass deflector from the mower because the grass deflector routes material down toward the turf. If the grass deflector is ever damaged, replace it immediately.
- Never put your hands or feet under the mower.
- Never try to clear the discharge area or mower blades unless you move the power take off (PTO) to the off position, rotate the ignition key to off and remove the key.
- Make sure the grass deflector is in the down position.

## Breaking In a New Machine

New engines take time to develop full power. Mower decks and drive systems have higher friction when new, placing additional load on the engine. Allow 40 to 50 hours of break-in time for new machines to develop full power and best performance.

## Transporting Machines

Use a heavy-duty trailer or truck to transport the machine. Ensure that the trailer or truck has all necessary lighting and marking as required by law. Please carefully read all the safety instructions. Knowing this information could help you, your family, pets or bystanders avoid injury.

To transport the machine:

- Lock the brake and block the wheels.
- Securely fasten the machine to the trailer or truck with straps, chains, cable, or ropes.

**Important:** Do not use the motion control levers as anchors for tying the machine down.

- Secure a trailer to the towing vehicle with safety chains.



Driving on the street or roadway without turn signals, lights, reflective markings, or a slow moving vehicle emblem is dangerous and can lead to accidents causing personal injury.

Do not drive machine on a public street or roadway.

## Loading Machines

Use extreme caution when loading units on trailers or trucks. One full width ramp that is wide enough to extend beyond the rear tires is recommended instead of individual ramps for each side of the unit (Figure 23). The lower rear section of the tractor frame extends back between the rear wheels and serves as a stop for tipping backward. Having a full width ramp provides a surface for the frame members to contact if the unit starts to tip backward. If it is not possible to use one full width ramp, use enough individual ramps to simulate a full width continuous ramp.

The ramp should be long enough so that the angles do not exceed 15 degrees (Figure 23). A steeper angle may cause mower components to get caught as the unit moves from ramp to trailer or truck. Steeper angles may also cause the unit to tip backward. If loading on or near a slope, position the trailer or truck so it is on the down side of the slope and the ramp extends up the slope. This will minimize the ramp angle. The trailer or truck should be as level as possible.

**Important:** Do Not attempt to turn the unit while on the ramp; you may lose control and drive off the side.

Avoid sudden acceleration when driving up a ramp and sudden deceleration when backing down a ramp. Both maneuvers can cause the unit to tip backward.



Loading a unit onto a trailer or truck increases the possibility of backward tip-over and could cause serious injury or death.

- Use extreme caution when operating a unit on a ramp.
- Use only a single, full width ramp; Do Not use individual ramps for each side of the unit.
- If individual ramps must be used, use enough ramps to create an unbroken ramp surface wider than the unit.
- Do not exceed a 15 degree angle between ramp and ground or between ramp and trailer or truck.
- Avoid sudden acceleration while driving unit up a ramp to avoid tipping backward.
- Avoid sudden deceleration while backing unit down a ramp to avoid tipping backward.

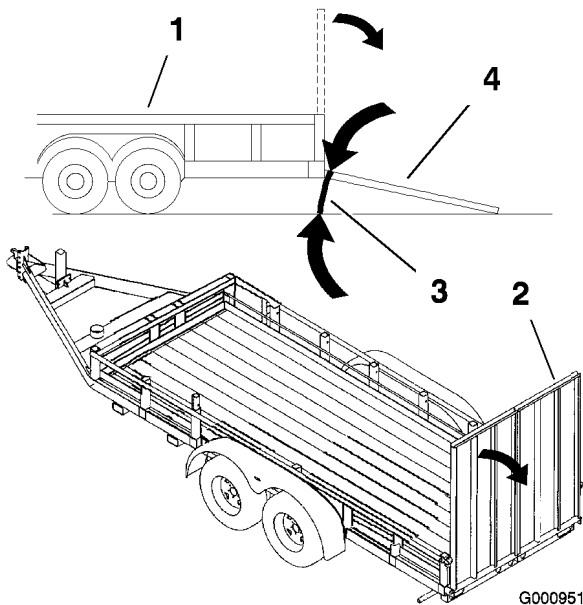

**Figure 23**

- |                    |                                |
|--------------------|--------------------------------|
| 1. Trailer         | 3. Not greater than 15 degrees |
| 2. Full width ramp | 4. Full width ramp—side view   |

## Operating Tips

### Fast Throttle Setting

For best mowing and maximum air circulation, operate the engine at the fast throttle position. Air is required to thoroughly cut grass clippings, so do not set the height-of-cut so low as to totally surround the mower by uncut grass. Always try to have one side of the mower free from uncut grass, which allows air to be drawn into the mower.

### Cutting a Lawn for the First Time

Cut grass slightly longer than normal to ensure the cutting height of the mower does not scalp any uneven ground. However, the cutting height used in the past is generally the best one to use. When cutting grass longer than six inches tall, you may want to cut the lawn twice to ensure an acceptable quality of cut.

### Cut 1/3 of the Grass Blade

It is best to cut only about 1/3 of the grass blade. Cutting more than that is not recommended unless grass is sparse, or it is late fall when grass grows more slowly.

### Mowing Direction

Alternate mowing direction to keep the grass standing straight. This also helps disperse clippings which enhances decomposition and fertilization.

### Mow at Correct Intervals

Normally, mow every four days. But remember, grass grows at different rates at different times. So to maintain the same cutting height, which is a good practice, mow more often in early spring. As the grass growth rate slows in mid summer, mow less frequently. If you cannot mow for an extended period, first mow at a high cutting height; then mow again two days later at a lower height setting.

### Cutting Speed

To improve cut quality, use a slower ground speed in certain conditions.

### Avoid Cutting Too Low

If the cutting width of the mower is wider than the mower you previously used, raise the cutting height to ensure that uneven turf is not cut too short.

## **Long Grass**

If the grass is ever allowed to grow slightly longer than normal, or if it contains a high degree of moisture, raise the cutting height higher than usual and cut the grass at this setting. Then cut the grass again using the lower, normal setting.

## **When Stopping**

If the machine's forward motion must be stopped while mowing, a clump of grass clippings may drop onto your lawn. To avoid this, move onto a previously cut area with the blades engaged.

## **Keep the Underside of the Mower Clean**

Clean clippings and dirt from the underside of the mower after each use. If grass and dirt build up inside the mower, cutting quality will eventually become unsatisfactory.

## **Blade Maintenance**

Maintain a sharp blade throughout the cutting season because a sharp blade cuts cleanly without tearing or shredding the grass blades. Tearing and shredding turns grass brown at the edges, which slows growth and increases the chance of disease. Check the cutter blades daily for sharpness, and for any wear or damage. File down any nicks and sharpen the blades as necessary. If a blade is damaged or worn, replace it immediately with a genuine TORO replacement blade.

# Maintenance

## Recommended Maintenance Schedule(s)

Maintenance Service Interval	Maintenance Procedure
After the first 8 operating hours	<ul style="list-style-type: none"> <li>• Change the engine oil.</li> <li>• Check the hydraulic fluid.</li> <li>• Change the hydraulic filter.</li> </ul>
Before each use or daily	<ul style="list-style-type: none"> <li>• Check the safety interlock system.</li> <li>• Check the engine oil.</li> <li>• Check the mower blades.</li> <li>• Clean the mower deck.</li> </ul>
Every 25 hours	<ul style="list-style-type: none"> <li>• Clean the foam air cleaner element (more often in duty or sandy conditions).</li> <li>• Check the hydraulic fluid.</li> </ul>
Every 50 hours	<ul style="list-style-type: none"> <li>• Grease the mower bearings.</li> <li>• Check the tire pressure.</li> <li>• Check the pump drive belt.</li> </ul>
Every 100 hours	<ul style="list-style-type: none"> <li>• Clean the paper air cleaner element (more often in duty or sandy conditions).</li> <li>• Change the engine oil.</li> <li>• Check the spark plug.</li> <li>• Clean the engine cylinder and cylinder head cooling fins</li> <li>• Check the hydraulic hoses.</li> </ul>
Every 150 hours	<ul style="list-style-type: none"> <li>• Lubricate the machine with light oil.</li> </ul>
Every 200 hours	<ul style="list-style-type: none"> <li>• Replace the paper air cleaner element (more often in duty or sandy conditions).</li> <li>• Change the engine oil filter.</li> <li>• Replace the fuel filter.</li> <li>• Change the hydraulic filter.</li> </ul>
Every 500 hours	<ul style="list-style-type: none"> <li>• Check the wheel hub slotted nut.</li> <li>• Adjust the caster pivot bearing.</li> </ul>
Yearly	<ul style="list-style-type: none"> <li>• Grease the front caster pivots (more often in dirty or dusty conditions).</li> </ul>

**Important:** Refer to your engine operator's manual for additional maintenance procedures.



If you leave the key in the ignition switch, someone could accidentally start the engine and seriously injure you or other bystanders.

Remove the key from the ignition and disconnect the wire from the spark plug(s) before you do any maintenance. Set the wire aside so that it does not accidentally contact the spark plug.

## Lubrication

more frequently when operating conditions are extremely dusty or sandy.

## Greasing and Lubrication

Grease Type: General-purpose grease.

Lubricate the machine when shown on the *Check Service Reference Aid decal* (Figure 24). Grease

## How to Grease

1. Disengage the PTO, move the motion control levers to the neutral locked position and set the parking brake.
2. Stop the engine, remove the key, and wait for all moving parts to stop before leaving the operating position.
3. Clean the grease fittings with a rag. Make sure to scrape any paint off the front of the fitting(s).
4. Connect a grease gun to the fitting. Pump grease into the fittings until grease begins to ooze out of the bearings.
5. Wipe up any excess grease.

## Greasing the Front Caster Pivots

Lubricate the front caster pivots once a year.

1. Remove the dust cap and adjust the caster pivots. Keep the dust cap off until greasing is done. Refer to Adjusting the Caster Pivot Bearing in Drive System Maintenance, page 37.
2. Remove the hex plug. Thread a grease zerk into the hole.
3. Pump grease into the zerk until it oozes out around the top bearing.
4. Remove the grease zerk in the hole. Install the hex plug and cap.

## Where to Add Grease

Lubricate the grease fittings as shown on the Check Service Reference Aid decal (Figure 24).

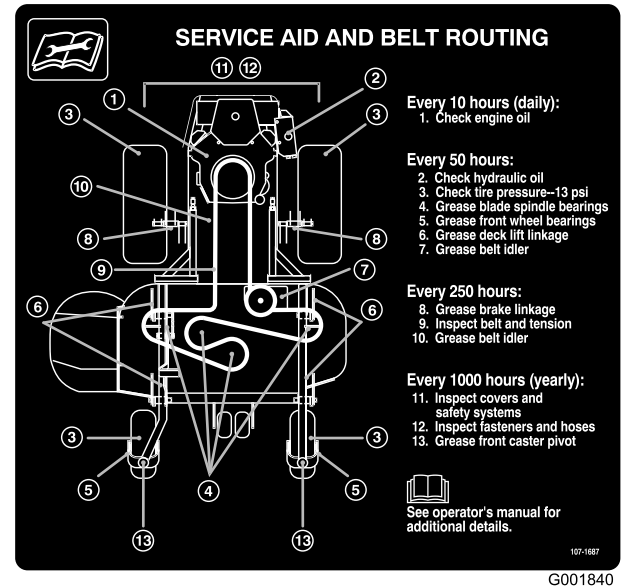

Figure 24

## Where to Add Light Oil or Spray Lubrication

Lubricate the machine in the following areas with spray type lubricant or light oil. Lubricate every 150 hours.

- Seat switch actuator.
- Brake handle pivot.
- Brake rod bushings.
- Motion control bronze bushings.

## Greasing the Bearings

Lubricate the cutting machine after every 50 operating hours. Grease with No. 2 general-purpose lithium-base or molybdenum-base grease.

1. Disengage the PTO, move the motion control levers to the neutral locked position, and set the parking brake.
2. Stop the engine, remove the key, and wait for all moving parts to stop before leaving the operating position.
3. Grease the fittings on the 3 spindle bearings (Fig. 38).

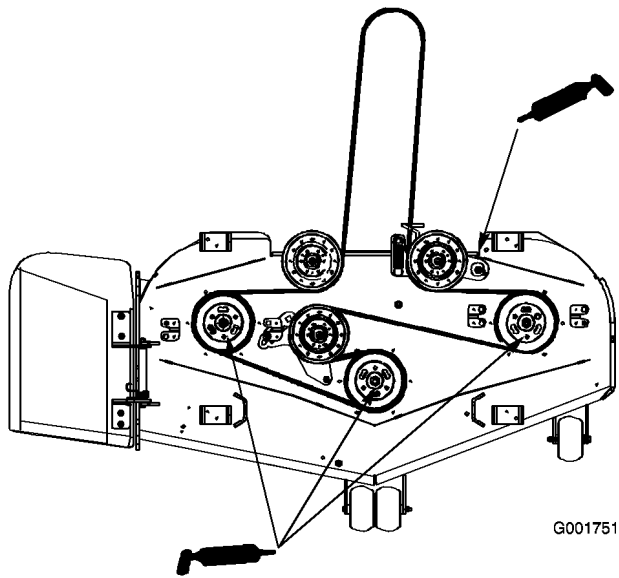

**Figure 25**

- Grease the idler pulley pivot (Fig. 38).

## Engine Maintenance

### Servicing the Air Cleaner

Service the air cleaner elements as follows:

- **Foam Element** Clean after every 25 operating hours.
- **Paper Element** Clean after every 100 operating hours; replace after every 200 operating hours or yearly, whichever occurs first.

**Note:** Check the filter more frequently (every few hours) if operating conditions are extremely dusty or sandy.

### Removing the Foam and Paper Elements

- Disengage the PTO, move the motion control levers to the neutral locked position and set the parking brake.
- Stop the engine, remove the key, and wait for all moving parts to stop before leaving the operating position.
- Clean around the air cleaner to prevent dirt from getting into the engine and causing damage. Unscrew the knob and remove the air cleaner cover (Figure 26).

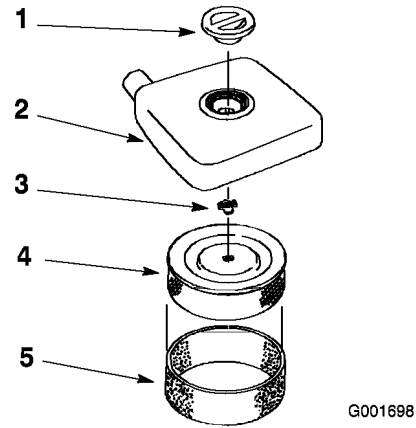

**Figure 26**

- |                      |                  |
|----------------------|------------------|
| 1. Knob              | 4. Paper element |
| 2. Air cleaner cover | 5. Foam element  |
| 3. Air cleaner nut   |                  |

- Carefully slide the foam element off the paper element (Figure 26).
- Unscrew the cover nut and remove the paper element (Figure 26).

### Cleaning the Foam Element

- Wash the foam element in liquid soap and warm water (Figure 27). When the element is clean, rinse it thoroughly.

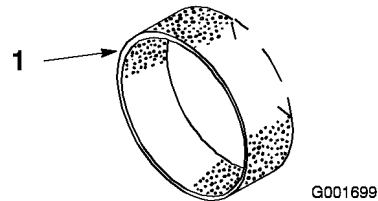

**Figure 27**

- Foam element

- Dry the element by squeezing it in a clean cloth (do not wring).

**Important:** Replace the foam element if it is torn or worn. Do not oil the foam element.

### Cleaning the Paper Element

- Lightly tap the element on a flat surface to remove dust and dirt (Figure 28).

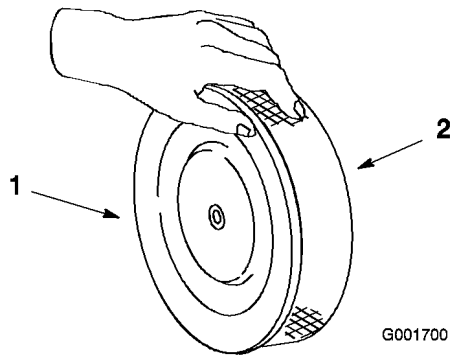

**Figure 28**

1. Paper element
2. Rubber seal

2. Inspect the element for tears, an oily film, and damage to the rubber seal.

**Important:** Never clean the paper element with pressurized air or liquids. Replace the paper element if it is damaged, or cannot be cleaned thoroughly.

### Installing the Foam and Paper Elements

**Important:** To prevent engine damage, always operate the engine with the complete foam and paper air cleaner assembly installed.

1. Carefully slide the foam element onto the paper air cleaner element (Figure 26).
2. Place the air cleaner assembly onto the air cleaner base (Figure 26).
3. Install the air cleaner and secure with cover nut (Figure 26).

### Servicing the Engine Oil

Change the engine oil as follows:

- After the first 8 operating hours.
- After every 100 operating hours.

**Oil Type:** Detergent oil (API service SF, SG, SH or SJ)

**Crankcase Capacity:** with a filter change, 57 ounces (1.7 l); without a filter change, 47 ounces (1.4 l)

**Viscosity:** See the table below.

### USE THESE SAE VISCOSITY OILS

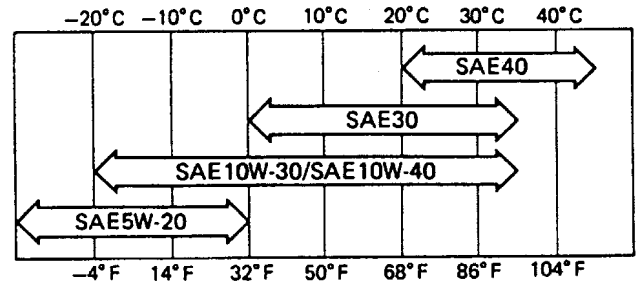

G000659

**Figure 29**

### Checking the Engine Oil Level

**Note:** Check the oil when the engine is cold.

1. Disengage the PTO, move the motion control levers to the neutral locked position and set the parking brake.
2. Stop the engine, remove the key, and wait for all moving parts to stop before leaving the operating position.
3. Clean around the oil dipstick (Figure 30) so dirt cannot fall into engine.

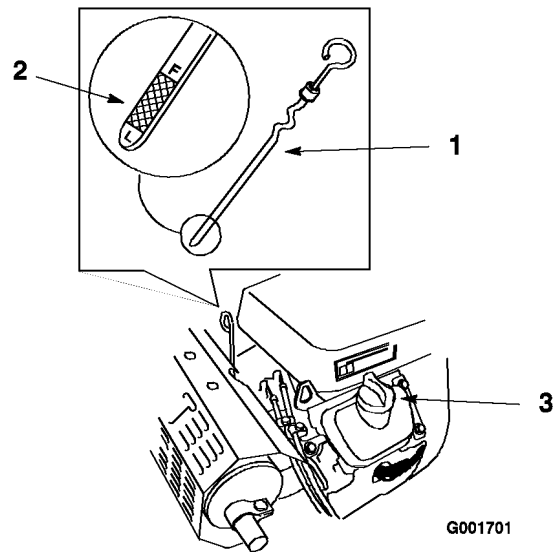

**Figure 30**

4. Pull the oil dipstick and wipe the metal end clean (Figure 30).
5. Slide the oil dipstick fully into the engine. Pull the dipstick out and look at the metal end (Figure 30). If oil level is low, slowly pour only

enough oil into the filler tube to raise the level to the full mark.

**Important:** Do not overfill the crankcase with oil because the engine may be damaged. Do not run engine with oil below the low mark because the engine may be damaged.

## Changing the Oil

1. Start the engine and let it run five minutes. This warms the oil so it drains better.
2. Park the machine so that the drain side is slightly lower than the opposite side to assure the oil drains completely.
3. Disengage the PTO and set the parking brake.
4. Stop the engine, remove the key, and wait for all moving parts to stop before leaving the operating position.
5. Slide the drain hose over the oil drain valve.
6. Place a pan below the drain hose. Rotate oil drain valve to allow oil to drain (Figure 31).
7. When oil has drained completely, close the drain valve.
8. Remove the drain hose (Figure 31).

**Note:** Dispose of the used oil at a recycling center.

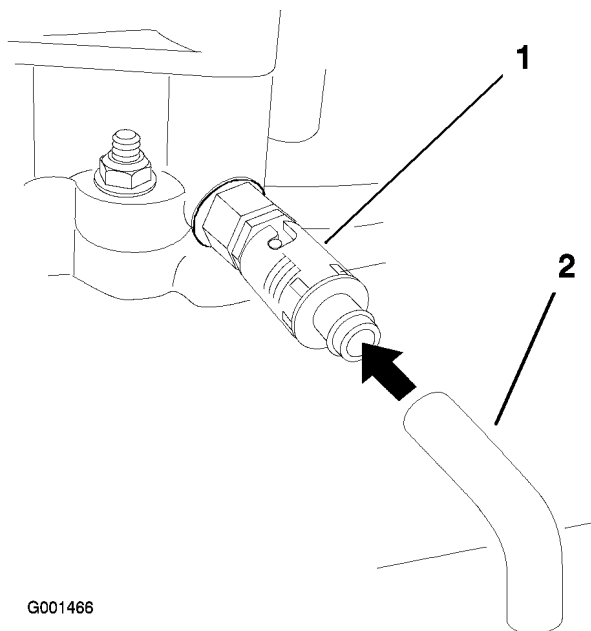

**Figure 31**

1. Oil drain valve
2. Oil drain hose

9. Slowly pour approximately 80% of the specified oil into the filler tube ( ).
10. Check the oil level; refer to Checking the Engine Oil Level.
11. Slowly add the additional oil to bring it to the Full mark.

## Changing the Engine Oil Filter

Replace the oil filter every 200 operating hours thereafter.

**Note:** Change the oil filter more frequently when operating conditions are extremely dusty or sandy.

1. Drain the oil from the engine; refer to Changing the Engine Oil.
2. Remove the old filter and wipe the filter adapter gasket surface (Figure 32).

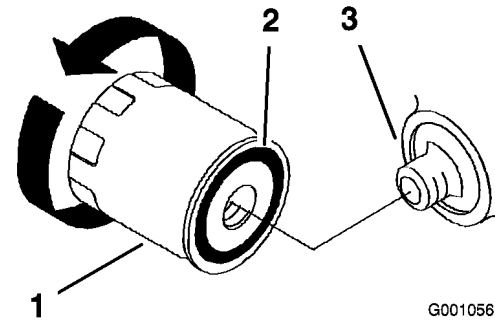

**Figure 32**

1. Oil filter
2. Gasket
3. Adapter

3. Pour new oil of the proper type in through the center hole. Stop pouring when the oil reaches the bottom of the threads. Allow a minute or two for the oil to be absorbed by filter material.
4. Apply a thin coat of new oil to the rubber gasket on the replacement filter (Figure 32).
5. Install the replacement oil filter to the filter adapter. Turn the oil filter clockwise until the rubber gasket contacts the filter adapter, then tighten the filter an additional 1/2 turn (Figure 32).
6. Fill the crankcase with the proper type of new oil; refer to Changing the Oil.

## Servicing the Spark Plug

Check the spark plug(s) after every 100 operating hours. Make sure the air gap between the center

and side electrodes is correct before installing the spark plug. Use a spark plug wrench for removing and installing the spark plug(s) and a gapping tool/feeler gauge to check and adjust the air gap. Install a new spark plug(s) if necessary.

- Type: NGK| BPR4ES or equivalent
- Air Gap: 0.030 inch (0.75 mm)

## Removing the Spark Plug

1. Disengage the PTO, move the motion control levers to the neutral locked position and set the parking brake.
2. Stop the engine, remove the key, and wait for all moving parts to stop before leaving the operating position.
3. Pull the wire(s) off the spark plug(s) (Figure 33). Now clean around the spark plug(s) to prevent dirt from falling into the engine and potentially causing damage.

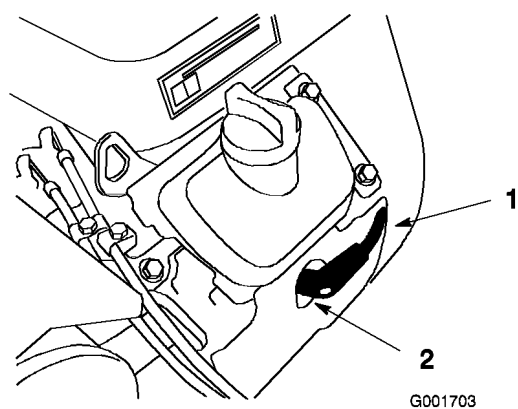

**Figure 33**

1. Spark plug wire
2. Spark plug

4. Remove the spark plug(s) and metal washer.

## Checking the Spark Plug

1. Look at the center of the spark plug(s) (Figure 34). If you see light brown or gray on the insulator, the engine is operating properly. A black coating on the insulator usually means the air cleaner is dirty.

**Important:** Never clean the spark plug(s). Always replace the spark plug(s) when it has: a black coating, worn electrodes, an oily film, or cracks.

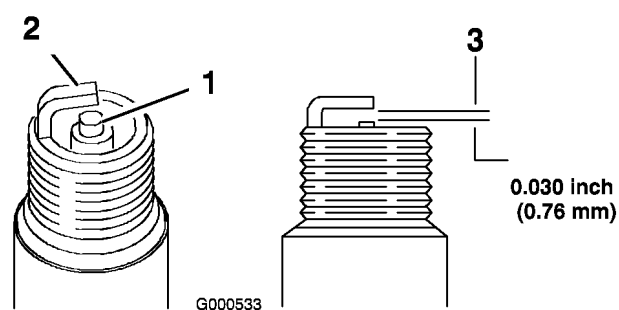

**Figure 34**

1. Center electrode insulator
2. Side electrode
3. Air gap (not to scale)

2. Check the gap between the center and side electrodes (Figure 34). Bend the side electrode (Figure 34) if the gap is not correct.

## Installing the Spark Plug

1. Install the spark plug(s). Make sure the air gap is set correctly.
2. Tighten the spark plug(s) to 16 ft.-lb (22 N·m).
3. Push the wire(s) onto the spark plug(s) (Figure 33).

# Fuel System Maintenance

## Replacing the Fuel Filter

Replace the fuel filter after every 200 operating hours or yearly, whichever occurs first.

Never install a dirty filter if it is removed from the fuel line.

1. Disengage the PTO, move the motion control levers to the neutral locked position and set the parking brake.
2. Stop the engine, remove the key, and wait for all moving parts to stop before leaving the operating position.
3. Allow the engine to cool down.
4. Close the fuel shut-off valve (Figure 35).

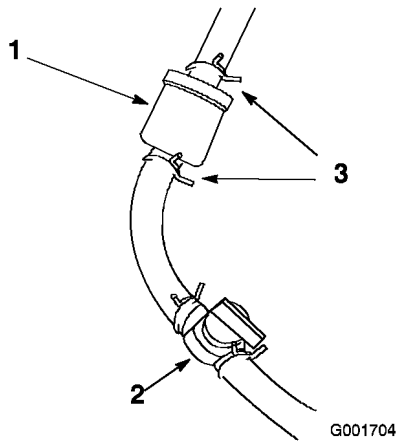

**Figure 35**

1. Filter  
2. Fuel shut-off valve  
3. Hose clamp

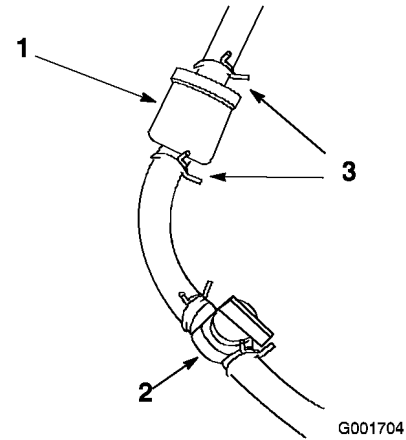

**Figure 36**

1. Filter  
2. Fuel shut-off valve  
3. Hose clamp

5. Squeeze the ends of the hose clamps together and slide them away from the filter (Figure 35).
6. Remove the filter from the fuel lines.
7. Install a new filter and move the hose clamps close to the filter to secure the fuel line (Figure 35).
8. Wipe up any spilled fuel.
9. Open the fuel shut-off valve.

4. Loosen the hose clamp at the fuel filter and slide it away from the fuel filter (Figure 36).
  5. Pull the fuel line off fuel filter (Figure 36). Open fuel shut-off valve and allow gasoline to drain into a gas can or drain pan.
- Note:** Now is the best time to install a new fuel filter because the fuel tank is empty.
6. Install the fuel line onto the fuel filter. Slide the hose clamp close to the fuel filter to secure the fuel line (Figure 36).

## Draining the Fuel Tank



In certain conditions, gasoline is extremely flammable and highly explosive. A fire or explosion from gasoline can burn you and others and can damage property.

- Drain gasoline from the fuel tank when the engine is cold. Do this outdoors in an open area. Wipe up any gasoline that spills.
- Never smoke when draining gasoline, and stay away from an open flame or where a spark may ignite the gasoline fumes.

1. Disengage the PTO, move the motion control levers to the neutral locked position and set the parking brake.
2. Stop the engine, remove the key, and wait for all moving parts to stop before leaving the operating position.

## Electrical System Maintenance

### Servicing the Battery

#### Warning

##### CALIFORNIA Proposition 65 Warning

Battery posts, terminals, and related accessories contain lead and lead compounds, chemicals known to the State of California to cause cancer and reproductive harm. Wash hands after handling.



Battery electrolyte contains sulfuric acid which is a deadly poison and causes severe burns.

Do not drink electrolyte and avoid contact with skin, eyes or clothing. Wear safety glasses to shield your eyes and rubber gloves to protect your hands.

## Removing the Battery



Battery terminals or metal tools could short against metal machine components causing sparks. Sparks can cause the battery gasses to explode, resulting in personal injury.

- When removing or installing the battery, do not allow the battery terminals to touch any metal parts of the machine.
- Do not allow metal tools to short between the battery terminals and metal parts of the machine.



Incorrect battery cable routing could damage the machine and cables causing sparks. Sparks can cause the battery gasses to explode, resulting in personal injury.

- Always Disconnect the negative (black) battery cable before disconnecting the positive (red) cable.
- Always Reconnect the positive (red) battery cable before reconnecting the negative (black) cable.

1. Disengage the PTO, move the motion control levers to the neutral locked position, and set the parking brake.
2. Stop the engine, remove the key, and wait for all moving parts to stop before leaving the operating position.
3. Unlatch the seat and tilt the seat up.
4. First disconnect the negative battery cable and ground wire from the negative (-) battery terminal (Figure 37).

5. Slide the red terminal boot off the positive (red) battery terminal. Then remove the positive (red) battery cable (Figure 37).

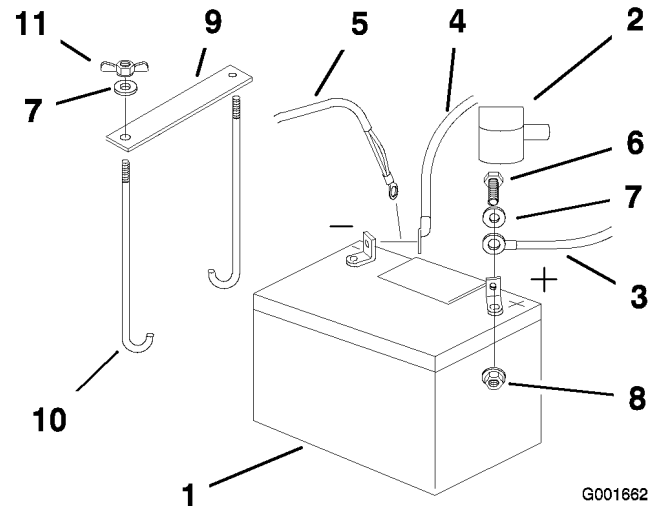

**Figure 37**

- |                           |                        |
|---------------------------|------------------------|
| 1. Battery                | 7. Washer (1/4 inch)   |
| 2. Terminal boot          | 8. Locknut (1/4 inch)  |
| 3. Positive battery cable | 9. Battery clamp       |
| 4. Negative battery cable | 10. J-bolts            |
| 5. Ground wire            | 11. Wingnut (1/4 inch) |
| 6. Bolt (1/4 x 3/4 inch)  |                        |

6. Remove both wing nuts (1/4 inch) securing the battery clamp (Figure 37).
7. Remove the battery.

## Installing the Battery

1. Position battery in the tray with the terminal posts toward the engine (Figure 37).
2. First, install the positive (red) battery cable to positive (+) battery terminal.
3. Then install the negative battery cable and ground wire to the negative (-) battery terminal.
4. Secure the cables with 2 bolts (1/4 x 3/4 inch), 2 washers (1/4 inch), and 2 locknuts (1/4 inch) (Figure 37).
5. Slide the red terminal boot onto the positive (red) battery post.
6. Secure battery with J-bolts, hold down clamp and 2 washers (1/4 inch), and 2 wing nuts (1/4 inch) (Figure 37).

## Charging the Battery



Charging the battery produces gasses that can explode.

Never smoke near the battery and keep sparks and flames away from battery.

**Important:** Always keep the battery fully charged (1.265 specific gravity). This is especially important to prevent battery damage when the temperature is below 32°F (0°C).

1. Remove the battery from the chassis.
2. Charge battery for 10 to 15 minutes at 25 to 30 amps or 30 minutes at 4-6 amps.
3. When the battery is fully charged, unplug the charger from the electrical outlet, then disconnect the charger leads from the battery posts (Fig. 67).

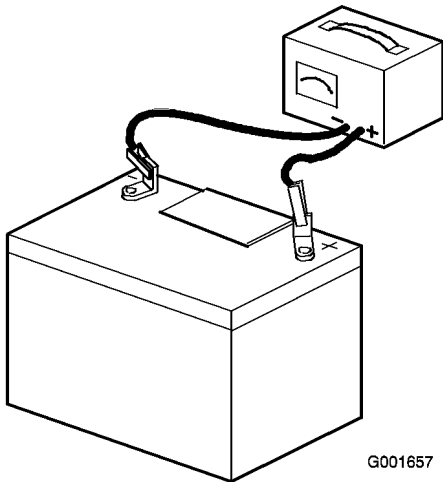

**Figure 38**

4. Install the battery in the machine and connect the battery cables; refer to Installing the Battery.

**Note:** Do not run the machine with the battery disconnected, electrical damage may occur.

## Servicing the Fuses

The electrical system is protected by fuses. It requires no maintenance, however, if a fuse blows check component/circuit for malfunction or short.

The fuses are as follows:

- Main F1-30 amp, blade-type
  - Alternator F2-25 amp, blade-type
1. Unlatch the seat and raise the seat to gain access to fuse holder (Figure 39).

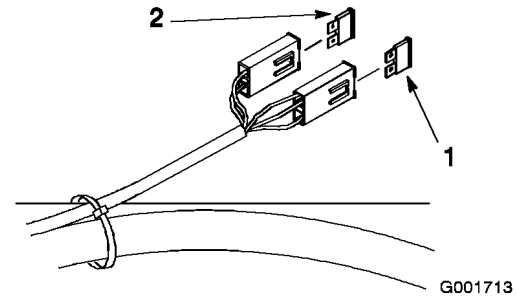

**Figure 39**

1. Main F1-30 amp
2. Alternator F2-25 amp

2. To replace the fuses, pull out on the fuse to remove it.
3. Install a new fuse (Figure 39).

# Drive System Maintenance

## Adjusting the Tracking

**Note:** Determine the left and right sides of the machine from the normal operating position.

The right hand pump has a knob for adjusting the tracking.

**Important:** Adjust the handle neutral and hydraulic pump neutral before adjusting the tracking. Refer to Adjusting the Handle Neutral and Adjusting the Hydraulic Pump Neutral.

1. Push both control levers forward the same distance.
2. Check if the machine pulls to one side. If it does, stop the machine and set the parking brake.
3. Unlatch the seat and tip the seat up to access the tracking knob.
4. Adjust the tracking as follows (Figure 40):
  - To make the machine go right, turn the knob towards the right side of the machine.
  - To make the machine go left, turn the knob towards the left side of the machine.

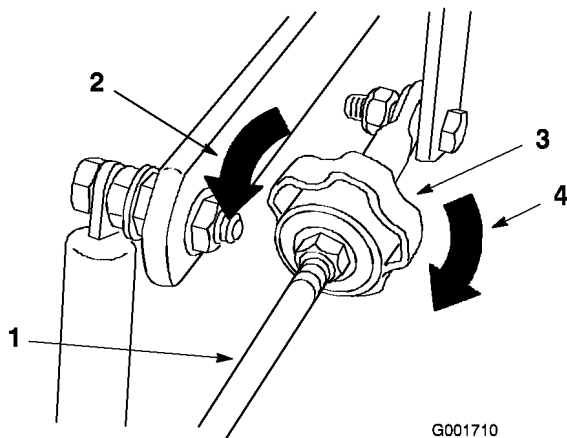

**Figure 40**

1. Pump rod
2. Turn this way to track left
3. Tracking knob
4. Turn this way to track right

5. Repeat this adjustment until the tracking is correct.

## Checking the Tire Pressure

Check the pressure at the valve stem after every 50 operating hours or monthly, whichever occurs first (Figure 41).

Maintain the air pressure in the front and rear tires at 13 psi (90 kPa). Uneven tire pressure can cause uneven cut. Check the tires when they are cold to get the most accurate pressure reading.

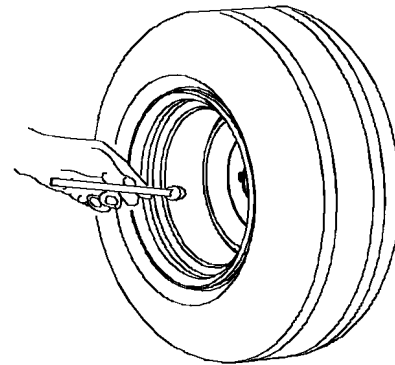

**Figure 41**

## Checking the Wheel Hub Slotted Nut

Check after every 500 operating hours.

The slotted nut needs to be torqued to 125 ft-lb (170 N·m).

1. Disengage the PTO, move the motion control levers to the neutral locked position and set the parking brake.
2. Stop the engine, remove the key, and wait for all moving parts to stop before leaving the operating position.
3. Remove the cotter pin.
4. Torque the slotted nut to 125 ft-lb (170 N·m) (Figure 42).

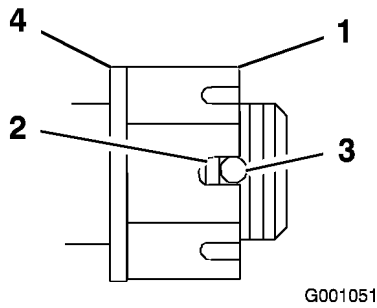

**Figure 42**

- |                                |                           |
|--------------------------------|---------------------------|
| 1. Slotted Nut                 | 3. Hole in threaded shaft |
| 2. Two threads or less showing | 4. Washer (if needed)     |

5. Check the distance from bottom of slot in nut to inside edge of hole. Two threads or less should be showing (Figure 42).
6. If more than two threads are showing remove nut and install washer between hub and nut.
7. Torque the slotted nut to 125 ft-lb. (170 N·m) (Figure 42).
8. Tighten the nut until the next set of slots line up with the hole in the shaft (Figure 42).
9. Replace the cotter pin.

## Adjusting the Caster Pivot Bearing

Check after every 500 operating hours or at storage, whichever comes first.

1. Disengage the PTO, move the motion control levers to the neutral locked position and set the parking brake.
2. Stop the engine, remove the key, and wait for all moving parts to stop before leaving the operating position.
3. Remove the dust cap from caster and tighten lock nut (Figure 43).

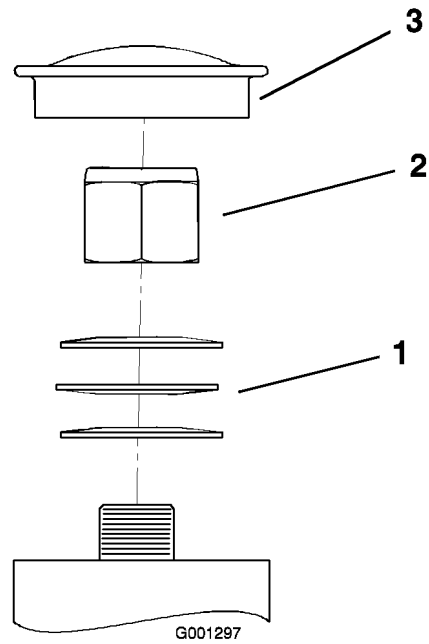

**Figure 43**

- |                   |             |
|-------------------|-------------|
| 1. Spring Washers | 3. Dust Cap |
| 2. Lock Nut       |             |

4. Tighten the locknut until the spring washers are flat and then back off a 1/4 turn to properly set the pre-load on the bearings (Figure 43).

**Important:** Make sure spring washers are installed correctly as shown in Figure 43.

5. Install the dust cap (Figure 43).

## Cooling System Maintenance

### Cleaning the Engine Screen and the Oil Cooler

Before each use, check and clean engine screen and oil cooler. Remove any build-up of grass, dirt or other debris from the oil cooler screen and engine screen (Figure 44 and Figure 45).

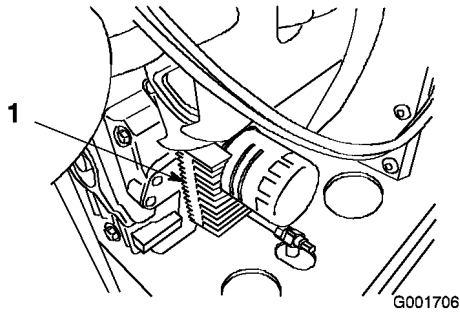

**Figure 44**

1. Oil cooler

## Cleaning the Engine Fins

Every 100 hours clean the engine cylinder and cylinder head cooling fins. Also clean around carburetor, governor levers and linkage. This will make sure adequate cooling to hydraulic pumps, motors and engine and will reduce the possibility of overheating and mechanical damage.

1. Remove the engine shroud.
2. Clean the engine cooling fins.
3. Install the engine shroud.

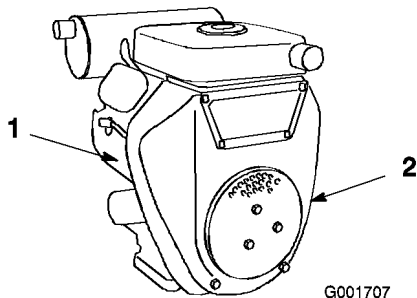

**Figure 45**

## Brake Maintenance

### Adjusting the Parking Brake

Check the parking brake for proper adjustment.

1. Disengage brake lever (lever down).
2. Measure the length of the spring.

The measurement should be 2-3/4 inch (70 mm) between washers (Figure 46).

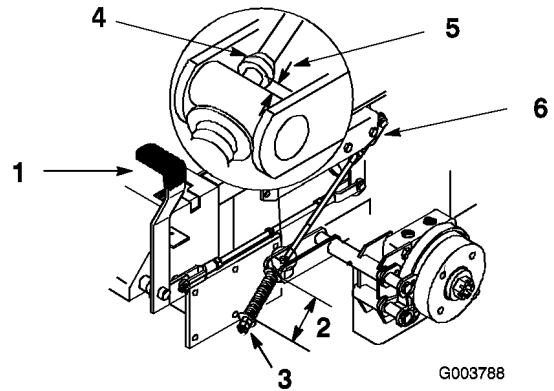

**Figure 46**

1. Brake lever
2. Spring (2-3/4 inches/70 mm)
3. Adjusting nuts
4. Collar on brake rod
5. 3/16-1/4 inch (5-7 mm)
6. Jam nut and yoke

3. If adjustment is necessary, loosen the jam nut below the spring and tighten the nut directly below the yoke (Figure 46). Turn the nut until the correct measurement is obtained. Tighten the two nuts together and repeat on opposite side of unit.
4. Turn nuts clockwise to shorten spring length and turn counter-clockwise to lengthen the spring.
5. Engage parking brake, lever up.
6. Measure the distance between the trunnion roller and the collar on brake rod.  
The measurement should be 3/16-1/4 inch (5-7 mm) (Figure 46).
7. If adjustment is necessary, loosen the jam nut directly below the yoke. Turn the bottom rod until the correct measurement is obtained (Figure 46). Tighten jam nut at yoke

## Belt Maintenance

### Replacing the Mower Belt

The signs of a worn mower belt are squealing while the belt is rotating, blades slipping while you are cutting grass, frayed belt edges, burn marks, and cracks. Replace the mower belt if you detect any of these signs.

1. Disengage the PTO, move the motion control levers to the neutral locked position, and set the parking brake.

2. Stop the engine, remove the key, and wait for all moving parts to stop before leaving the operating position.
3. Remove the belt covers over the outside spindles.
4. Loosen the fixed idler arm and adjust it to relieve the belt tension on the fixed idler pulley (Figure 47).

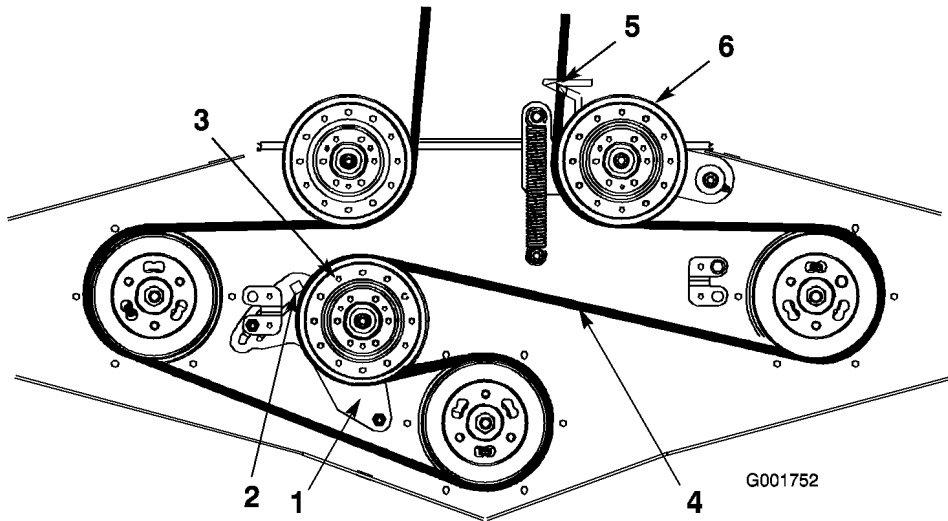

**Figure 47**

- |                    |                       |                               |
|--------------------|-----------------------|-------------------------------|
| 1. Fixed idler arm | 3. Fixed idler pulley | 5. Belt guide                 |
| 2. Square hole     | 4. Mower belt         | 6. Spring-loaded idler pulley |

5. Remove the old belt.
6. Install the new belt through the belt guide and on the pulleys (Figure 47).
7. Insert a ratchet with a short extension or a breaker bar into the square hole in the fixed idler arm (Figure 48).

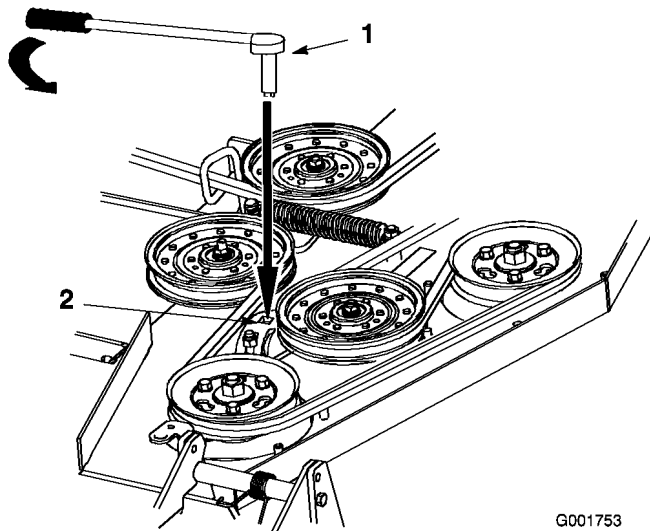

**Figure 48**

- |                                 |                               |
|---------------------------------|-------------------------------|
| 1. Ratchet with short extension | 2. Square hole or breaker bar |
|---------------------------------|-------------------------------|

8. To increase the belt tension, rotate the ratchet or breaker bar counterclockwise to move the fixed idler arm until you feel increased resistance and the spring-loaded idler pulley stops moving.

**Note:** Do not increase the belt tension beyond the point where the fixed idler arm stops.

9. While holding the belt in tension, tighten the 2 bolts that secure the fixed idler arm.
10. Remove the ratchet or breaker bar from the square hole in the fixed idler arm.
11. Install the belt covers the outside spindles.

## Replacing the Pump Drive Belt

Check pump drive belt for wear after every 50 hours of operation.

1. Pull the spring loaded idler down and remove traction belt from the engine and hydro pump pulleys (Figure 49). Remove belt between pulleys.

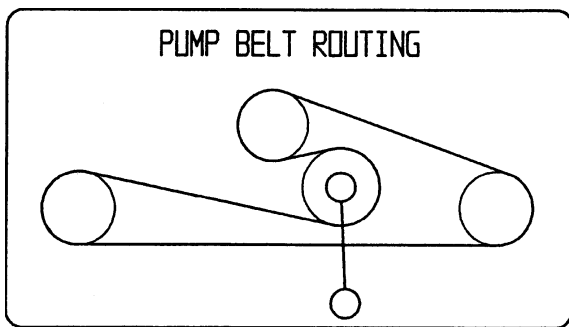

G001711

**Figure 49**

2. Install new belt around engine and hydro pump pulleys (Figure 49).
3. Pull spring loaded idler down and align below traction belt. Release the pressure on the spring loaded idler (Figure 49).

## Controls System Maintenance

### Adjusting the Control Handle Neutral Position

If motion control levers do not align, or move easily into the console notch, adjustment is required. Adjust each lever, spring and rod separately.

**Note:** Motion control levers must be installed correctly. See Installing the Motion Control Levers in the set up instructions.

1. Disengage the PTO, move the motion control levers to the neutral locked position and set the parking brake.
2. Stop the engine, remove the key, and wait for all moving parts to stop before leaving the operating position.
3. Unlatch the seat and tilt the seat forward.
4. Begin with either the left or right motion control lever.
5. Move the lever to the neutral position but not locked (Figure 50).

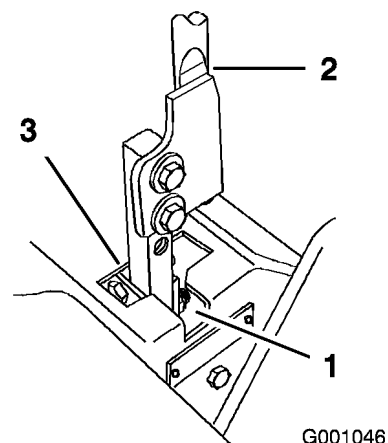

G001046

**Figure 50**

1. Neutral locked position
2. Control lever
3. Neutral position

6. Pull the lever back until the clevis pin (on arm below pivot shaft) contacts the end of the slot (just beginning to put pressure on the spring) (Figure 50).
  7. Check where the control lever is relative to notch in console (Figure 50). It should be centered allowing lever to pivot outward to the neutral lock position.
  8. If adjustment is needed, loosen the nut and jam nut against the yoke (Figure 51).
  9. Apply slight rearward pressure on the motion control lever, turn the head of the adjustment bolt in the appropriate direction until the control lever is centered in the neutral lock position (Figure 51).
- Note:** Keeping rearward pressure on the lever will keep the pin at the end of the slot and allow the adjustment bolt to move the lever to the appropriate position.
10. Tighten the nut and jam nut (Figure 51).
  11. Repeat for the opposite side of the machine.

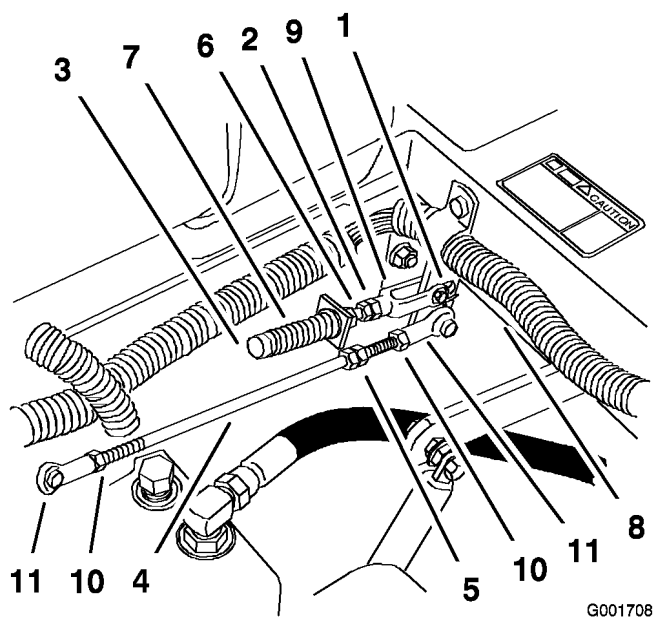

**Figure 51**

- |                       |                |
|-----------------------|----------------|
| 1. Clevis pin in slot | 7. Spring      |
| 2. Nut against yoke   | 8. Pivot shaft |
| 3. Adjustment bolt    | 9. Yoke        |
| 4. Pump rod           | 10. Locknut    |
| 5. Double nuts        | 11. Ball joint |
| 6. Jam nut            |                |

## Mercury Tilt Switch

The tilt switch on this unit contains mercury, a hazardous material. Mercury that is outside a sealed container vaporizes at room temperature. The vapors are harmful. Mercury can be absorbed through the skin. Do not attempt to open or repair this switch.

A very small amount of mercury is contained in a hermetically sealed body. The steel switch is then potted in a hard epoxy in a plastic case. It is unlikely that the mercury will ever escape from the enclosure. These high performance and reliable inexpensive switches are recyclable.

Mercury is an important and beneficial compound but requires special care in handling and disposal. When used and managed properly, mercury is not a threat to people or the environment. This information is presented to users so that they are aware that these switches contain mercury and will apply sound disposal practices when these devices reach their normal end of life or are damaged.

## Disposing the Mercury Tilt Switch

Several states have passed laws concerning the disposal of devices containing mercury. In all the remaining states it is advisable to follow similar procedures. The laws state that these sealed devices contain mercury and should not be placed in the garbage until the mercury is removed and reused, recycled or otherwise managed to insure that it does not become part of solid waste or waters. Management and disposal practices must be within relevant federal, state or local laws.

Return the switch to your Toro dealer if it is faulty and is being replaced or if the unit containing the switch is no longer operating and is being scrapped. If the switch is damaged or broken open use extreme caution in handling. Call your local waste management authority or Toro Customer Service for instructions.



**The mercury contained in the tilt switch is poisonous and exposure to mercury can cause severe illness.**

- Never attempt to open or repair the tilt switch.
- Avoid contact with the mercury.

## Hydraulic System Maintenance

### Checking the Hydraulic Fluid

Check the hydraulic fluid level:

- Before the engine is first started.
- After the first 8 operating hours.
- After every 25 operating hours.

Fluid Type: Mobil 1 15W-50 synthetic motor oil or equivalent synthetic oil.

**Important: Use oil specified or equivalent. Other fluids could cause system damage.**

Hydraulic System Oil Capacity: 67 oz. (2.0 l)

**Note:** There are two ways of checking the hydraulic oil. One is when the oil is warm and one is when the oil is cold. The baffle inside the tank has two levels depending if the oil is warm or cold.

1. Position the machine on a level surface and set the parking brake.
2. Clean the area around filler neck of hydraulic tank (Figure 52).

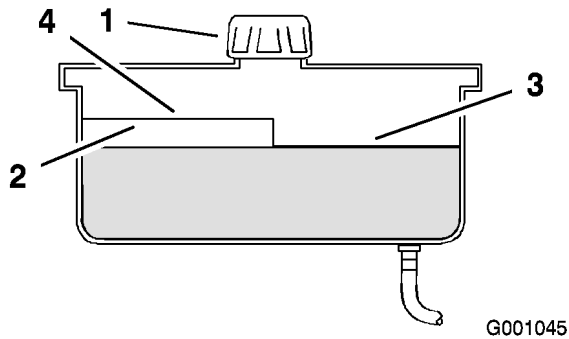

**Figure 52**

- |           |                          |
|-----------|--------------------------|
| 1. Cap    | 3. Cold fluid level-full |
| 2. Baffle | 4. Hot fluid level-full  |

3. Remove the cap from the filler neck. Look inside to check if there is fluid in the reservoir (Figure 52).
4. If there is no fluid, add fluid to the reservoir until it reaches the cold level of the baffle.
5. Run the machine at low idle for 15 minutes to allow any air to purge out of the system and warm the fluid. Refer to Starting and Stopping the Engine in Operation, page 15.
6. Recheck the fluid level while the fluid is warm. The fluid should be between cold and hot.
7. If required, add fluid to the hydraulic tank.

**Note:** The fluid level should be to the top of the hot level of the baffle, when the fluid is hot (Figure 52).

8. Install cap on filler neck.



**Hydraulic fluid escaping under pressure can penetrate skin and cause injury.**

- If hydraulic fluid is injected into the skin it must be surgically removed within a few hours by a doctor familiar with this type of injury. Gangrene may result if this is not done.
- Keep body and hands away from pin hole leaks or nozzles that eject high pressure hydraulic fluid.
- Use cardboard or paper to find hydraulic leaks.
- Safely relieve all pressure in the hydraulic system before performing any work on the hydraulic system.
- Make sure all hydraulic fluid hoses and lines are in good condition and all hydraulic connections and fittings are tight before applying pressure to hydraulic system.

## Replacing the Hydraulic Filter and Oil

Change the hydraulic filter:

- After the first 8 operating hours.
- After every 200 operating hours.

Use summer filter above 32°F (0°C)

Use winter filter below 32°F (0°C)

1. Disengage the PTO, move the motion control levers to the neutral locked position and set the parking brake.
2. Stop the engine, remove the key, and wait for all moving parts to stop before leaving the operating position.

**Important:** Do not substitute automotive oil filter or severe hydraulic system damage may result.

3. Place drain pan under filter, remove the old filter and wipe the filter adapter gasket surface clean (Figure 53).

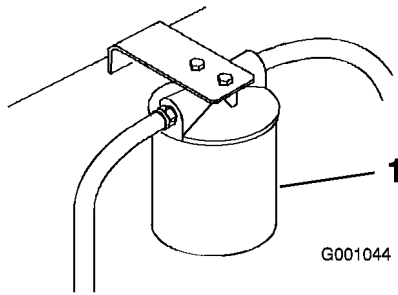

**Figure 53**

1. Hydraulic filter

4. Apply a thin coat hydro fluid to the rubber gasket on the replacement filter (Figure 54).

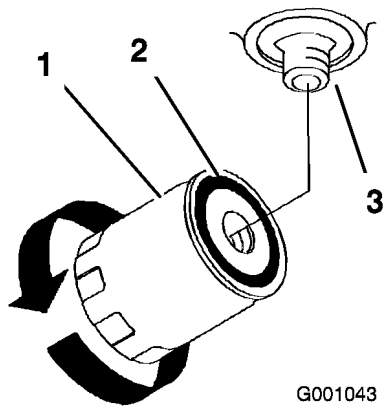

**Figure 54**

1. Hydraulic filter
2. Gasket
3. Adapter

5. Install the replacement hydraulic filter onto the filter adapter. Do not tighten.
6. Fill the hydraulic tank with hydraulic fluid until the fluid overflows the filter and then turn the oil filter clockwise until the rubber gasket contacts the filter adapter, then tighten the filter an additional 1/2 turn (Figure 54).
7. Clean up any spilled fluid.
8. Add fluid to the cold level of the baffle in the hydraulic tank.
9. Start the engine and let it run for about two minutes to purge air from the system. Stop the engine and check for leaks. If one or both wheels will not drive, refer Bleeding Hydraulic System.
10. Recheck the fluid level while the fluid is warm. The fluid should be between cold and hot.
11. If required, add fluid to the hydraulic tank. Do not overfill.

## Bleeding the Hydraulic System

The traction system is self bleeding, however, it may be necessary to bleed the system if fluid is changed or after work is performed on the system.

1. Raise rear of the machine so wheels are off the ground and support with jack stands.
2. Start the engine and run at low idle speed. Engage the lever and traction on one side and spin the wheel by hand.
3. When the wheel begins to spin on its own, keep it engaged until wheel drives smoothly. (minimum 2 minutes)
4. Check hydraulic fluid level and add as required to maintain proper level.
5. Repeat this procedure on the opposite wheel.

## Checking the Hydraulic Hoses

After every 100 operating hours, check the hydraulic hoses for leaks, loose fittings, kinked lines, loose mounting supports, wear, weather and chemical deterioration. Make necessary repairs before operating.

**Note:** Keep areas around the hydraulic system clean from grass and debris build up.



Hydraulic fluid escaping under pressure can penetrate skin and cause injury.

- If hydraulic fluid is injected into the skin it must be surgically removed within a few hours by a doctor familiar with this type of injury. Gangrene may result if this is not done.
- Keep body and hands away from pin hole leaks or nozzles that eject high pressure hydraulic fluid.
- Use cardboard or paper to find hydraulic leaks.
- Safely relieve all pressure in the hydraulic system before performing any work on the hydraulic system.
- Make sure all hydraulic fluid hoses and lines are in good condition and all hydraulic connections and fittings are tight before applying pressure to hydraulic system.

## Setting the Hydraulic Pump Neutral Position

**Note:** Adjust the handle neutral first. That needs to be correct before the following adjustment can be made.



Mechanical or hydraulic jacks may fail to support machine and cause a serious injury.

- Use jack stand when supporting machine.
- Do not use hydraulic jacks.



Engine must be running so motion control adjustment can be performed. Contact with moving parts or hot surfaces may cause personal injury.

Keep hands, feet, face, clothing and other body parts away from rotating parts, muffler and other hot surfaces.

This adjustment must be made with drive wheels turning.

1. Raise the frame and use jack stands to hold up the machine so drive wheels can rotate freely.
2. Unlatch the seat, tilt the seat forward and disconnect electrical connector from the seat safety switch.
3. **Temporarily** install a jumper wire across terminals in the wiring harness connector.
4. Slide the seat forward, disconnect the prop rod and tilt the seat fully forward.

## Setting the Right-hand Hydraulic Pump Neutral Position

1. Start the engine, open the throttle 1/2 way and release parking brake. Refer to Starting and Stopping the Engine in Operation, page 15.

**Note:** The motion control lever must be in neutral while making any adjustments.

2. Adjust the pump rod length by rotating the knob, in the appropriate direction, until the wheel is still or slightly creeping in reverse (Figure 55).

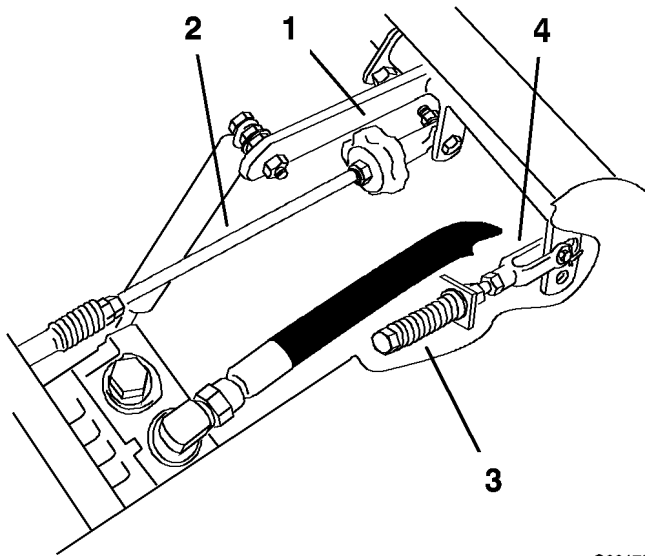

**Figure 55**

- |                  |                    |
|------------------|--------------------|
| 1. Tracking knob | 3. Adjustment bolt |
| 2. Pump rod      | 4. Yoke            |

3. Move the motion control lever forward and reverse, then back to neutral. The wheel must stop turning or slightly creep in reverse.
4. Open the throttle to fast. Make sure wheel remains stopped or slightly creeps in reverse, adjust if necessary.

### Setting the Left-hand Hydraulic Pump Neutral Position

1. Loosen the locknuts at the ball joints on the pump control rod (Figure 56).

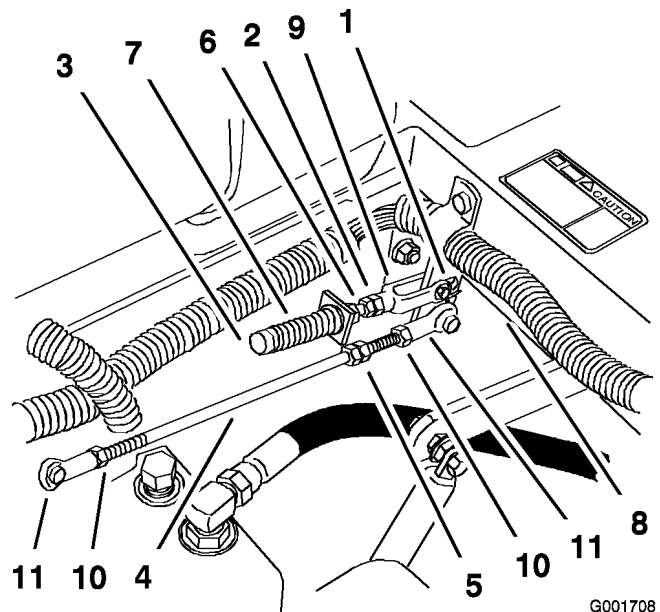

**Figure 56**

- |                       |                |
|-----------------------|----------------|
| 1. Clevis pin in slot | 7. Spring      |
| 2. Nut against yoke   | 8. Pivot shaft |
| 3. Adjustment bolt    | 9. Yoke        |
| 4. Pump rod           | 10. Locknut    |
| 5. Double nuts        | 11. Ball joint |
| 6. Jam nut            |                |

2. Start the engine, open throttle 1/2 way, and release parking brake. Refer to Starting and Stopping the Engine in Operation, page 15.

**Note:** The motion control lever must be in neutral while making any adjustments.

**Note:** The front nut on the pump rod has left-hand threads.

3. Adjust the pump rod length by rotating double nuts on rod, in the appropriate direction, until wheel is still or slightly creeps in reverse (Figure 56).
4. Move the motion control lever forward and reverse, then back to neutral. The wheel must stop turning or slightly creep in reverse.
5. Open the throttle to fast. Make sure the wheel remains stopped or slightly creeps in reverse, adjust if necessary.
6. Tighten the locknuts at the ball joints (Figure 56).



**Electrical system will not perform proper safety shut off with jumper wire installed.**

- Remove jumper wire from wire harness connector and plug connector into seat switch when adjustment is completed.
- Never operate this unit with jumper installed and seat switch bypassed.

7. After both pump neutrals are set, shut off the machine.
8. Remove the jumper wire from the wire harness connector and plug the connector into the seat switch.
9. Install the seat rod and lower the seat into position.
10. Remove the jack stands.

## Mower Deck Maintenance

### Leveling the Mower at Three Positions

**Important:** There are only three measuring positions needed to level the mower.

#### Setting Up the Machine

1. Position mower on a flat surface.
2. Disengage the PTO, move the motion control levers to the neutral locked position and set the parking brake.
3. Stop the engine, remove the key, and wait for all moving parts to stop before leaving the operating position.
4. Check tire pressure of all four tires. If needed, adjust to 13 psi (90 kPa)
5. Lower the mower to the 3 inch (76 mm) height-of-cut position.
6. Inspect the four chains. The chains need to have tension.

**Note:** Adjust the rear chains to the top of the slot, where they are attached to the mower.

- If one rear chain is loose, lower (loosen) the front support arm on the same side. Refer to Adjusting the Front-to-Rear Mower Pitch.
- If one front chain is loose, raise (tighten) the front support arm for that chain. Refer to Adjusting the Front-to-Rear Mower Pitch.

### Leveling the Mower Side-to-Side

1. Position the **right** blade front-to-rear (Figure 57).

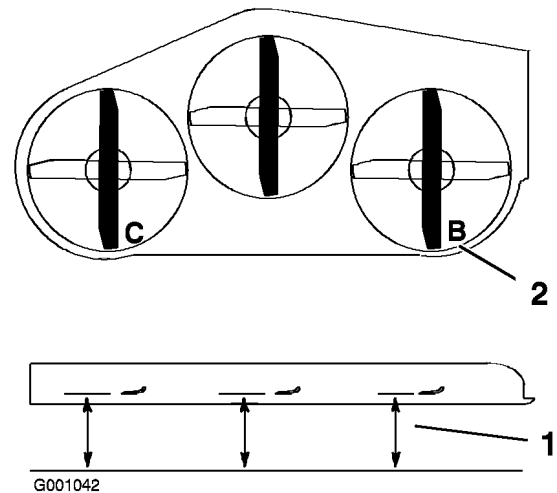

**Figure 57**

1. Measure here from blade to hard surface
2. Measure at B and C to hard surface
2. Measure the right blade at the **B** location, from a level surface to the cutting edge of the blade tip (Figure 57).
3. Record this measurement. This measurement needs to be 3-1/8 to 3-1/4 inches.
4. Position the left blade front-to-rear (Figure 57).
5. Measure the left blade at the **C** location (Figure 57), from a level surface to the cutting edge of the blade tip .
6. Record this measurement. This measurement needs to be 3-1/8 to 3-1/4 inches.
7. If the measurements at positions **B** or **C** are not correct, loosen the bolt attaching the rear chain to the rear support arm (Figure 58).

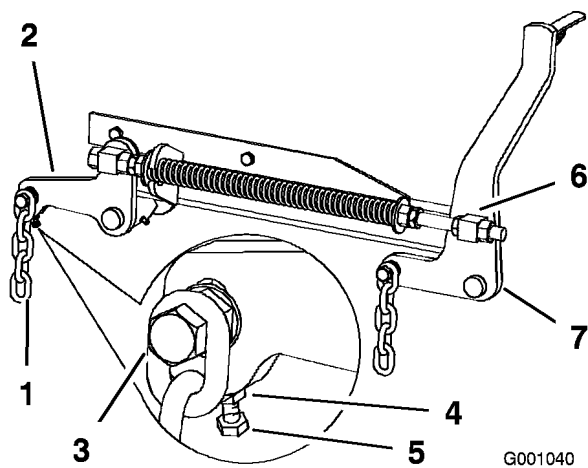

**Figure 58**

- |                     |                      |
|---------------------|----------------------|
| 1. Rear chain       | 5. Adjustment bolt   |
| 2. Rear support arm | 6. Front swivel      |
| 3. Bolt             | 7. Front support arm |
| 4. Jam Nut          |                      |

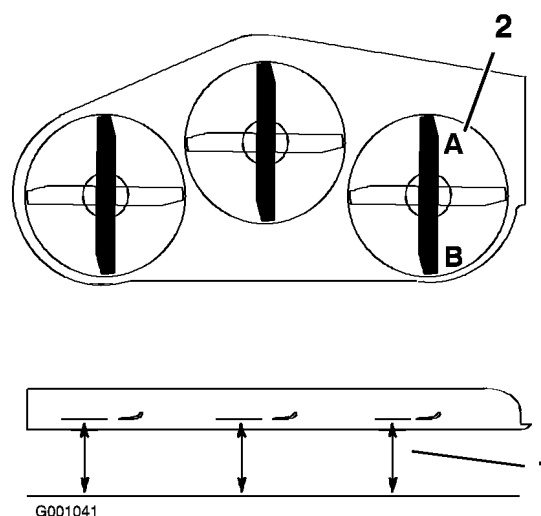

**Figure 59**

1. Measure here from blade to hard surface
2. Measure at A and B

8. Loosen the jam nut under the rear support arm and adjust the adjustment bolt to get a measurement of 3-1/8 to 3-1/4 inches (Figure 58).
 

**Note:** It is recommended that both sides of the mower are adjusted the same distance.
9. Tighten the jam nut under the rear support arm and tighten the bolt securing the chain to the rear support arm.
10. Adjust the opposite side if needed.

### Adjusting the Front-to-Rear Mower Pitch

1. Position the **right** blade front-to-rear (Figure 59).

2. Measure the right blade at the **A** location, from a level surface to the cutting edge of the blade tip (Figure 59).
3. Record this measurement.
4. Measure the right blade at the **B** location, from a level surface to the cutting edge of the blade tip (Figure 59).
5. Record this measurement.
6. The mower blade should be a 1/4 to 3/8 inch (6 to 10 mm) lower at position **A** than at position **B** (Figure 59). If it is not correct, proceed to the following steps.

**Note:** Both of the front swivels need to be adjusted the same amount to maintain equal chain tension.

7. Loosen the front swivel jam nuts, at the front of the right and left swivels, approximately a 1/2 inch (13 mm) (Figure 58).
8. Adjust the lift nuts on both the left and the right side of the machine to achieve 1/4 to 3/8 inch (6 to 10 mm) lower in front at **A** than in the rear at **B** (Figure 58).
9. Tighten both swivel jam nuts against the front swivel to lock the height.
10. Check to make sure there is equal tension on the chains and adjust again if needed.

## Adjusting the Compression Spring

1. Raise the mower lift lever to the transport position.
2. Check the distance between the two large washers, it needs to be 11-1/8 inches (28.2 cm) for 52 inch mower decks and 10-1/2 inches (26.7 cm) for 60 inch mower decks (Figure 60).

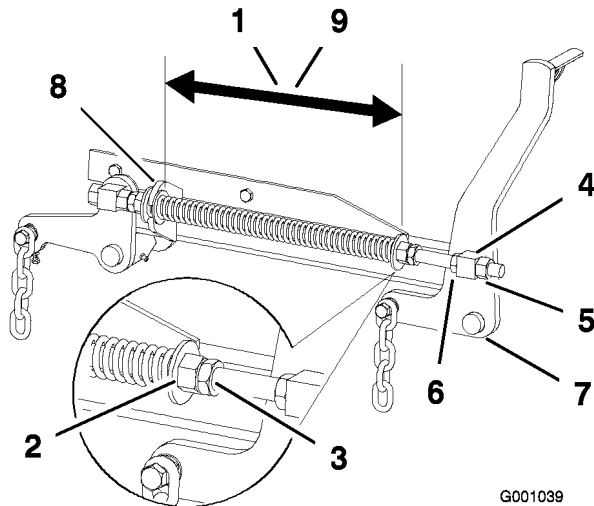

**Figure 60**

- |  |  |
|--|--|
| 1. 11-1/8 inch (28.2 cm) between the large washers for 52 inch mower decks | 6. Lift nut  |
| 2. Front nut   | 7. Front support arm   |
| 3. Spring jam nut  | 8. Large washer  |
| 4. Front swivel  | 9. 10-1/2 inch (26.7 cm) between the large washers for 60 inch mower decks |
| 5. Swivel jam nut  |  |

3. Adjust this distance, by loosening the spring jam nut and turning the nut in front of each spring (Figure 60). Turning the nut clockwise will shorten the spring; counter-clockwise will lengthen the spring.
4. Lock the nut into position by tightening the spring jam nut (Figure 60).

## Servicing the Cutting Blades

Maintain sharp blades throughout the cutting season because sharp blades cut cleanly without tearing or shredding the grass blades. Tearing and shredding turns grass brown at the edges, which slows growth and increases the chance of disease.

Check the cutter blades daily for sharpness, and for any wear or damage. File down any nicks and sharpen the blades as necessary. If a blade is

damaged or worn, replace it immediately with a genuine Toro replacement blade. For convenient sharpening and replacement, you may want to keep extra blades on hand.



**A worn or damaged blade can break, and a piece of the blade could be thrown into the operator's or bystander's area, resulting in serious personal injury or death.**

- Inspect the blade periodically for wear or damage.
- Replace a worn or damaged blade.

Inspect and check the blades every 8 hours.

### Before Inspecting or Servicing the Blades

1. Park the machine on a level surface, disengage the blade control (PTO), and set the parking brake.
2. Turn the ignition key to Off and remove the key.
3. Disconnect the spark plug wire(s) from the spark plug(s).

### Inspecting the Blades

1. Inspect the cutting edges (Figure 61).

If the edges are not sharp or have nicks, remove and sharpen the blades. Refer to *Sharpening the Blades*.

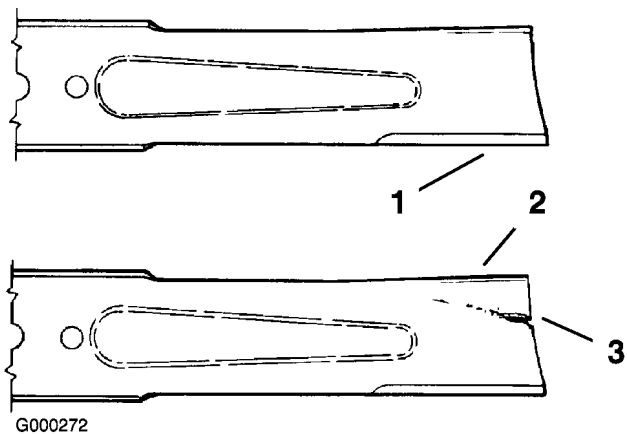

**Figure 61**

1. Cutting Edge
2. Curved Area
3. Wear/slot Forming

2. Inspect the blades, especially the curved area (Figure 61).

If you notice any damage, wear, or a slot forming in this area (Figure 61), immediately install a new blade.

### Checking for Bent Blades

1. Rotate the blades until the ends face forward and backward (Figure 62). Measure from a level surface to the cutting edge, position **A**, of the blades (Figure 62). Note this dimension.

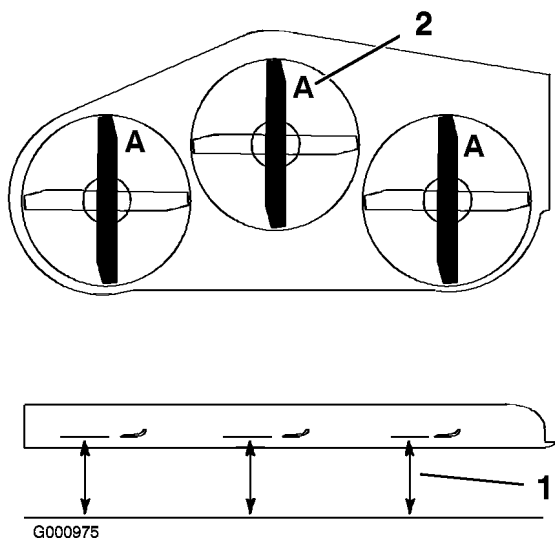

**Figure 62**

1. Measure here from blade to hard surface
2. Position A

2. Rotate the opposite ends of the blades forward.
3. Measure from a level surface to the cutting edge of the blades at the same position as in step 1 above.

The difference between the dimensions obtained in steps 1 and 2 must not exceed 1/8 inch (3 mm). If this dimension exceeds 1/8 inch (3 mm), the blade is bent and must be replaced; refer to Removing the Blades and Installing the Blades.



**A blade that is bent or damaged could break apart and could seriously injure or kill you or bystanders.**

- Always replace bent or damaged blade with a new blade.
- Never file or create sharp notches in the edges or surfaces of blade.

### Removing the Blades

Blades must be replaced if a solid object is hit, if the blade is out of balance or is bent. To ensure optimum performance and continued safety conformance of the machine, use genuine Toro replacement blades. Replacement blades made by other manufacturers may result in non-conformance with safety standards.



**Contact with a sharp blade can cause serious injury.**

**Wear gloves or wrap sharp edges of the blade with a rag.**

1. Hold the blade end using a rag or thickly-padded glove.
2. Remove the blade bolt, spring disk and blade from the spindle shaft (Figure 65).

## Sharpening the Blades



When sharpening blade, pieces of blade could be thrown and cause serious injury.

Wear proper eye protection when sharpening blade.

1. Use a file to sharpen the cutting edge at both ends of the blade (Figure 63). Maintain the original angle. The blade retains its balance if the same amount of material is removed from both cutting edges.

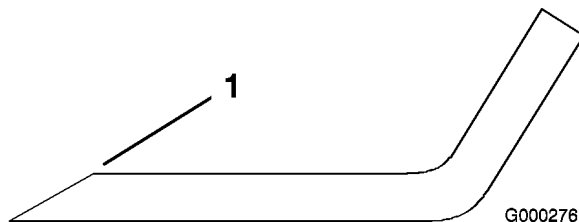

Figure 63

1. Sharpen at original angle
- 
2. Check the balance of the blade by putting it on a blade balancer (Figure 64). If the blade stays in a horizontal position, the blade is balanced and can be used. If the blade is not balanced, file some metal off the end of the sail area only (Figure 65). Repeat this procedure until the blade is balanced.

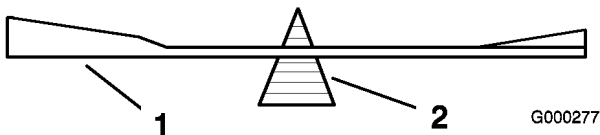

Figure 64

1. Blade
2. Balancer

## Installing the Blades

1. Install the blade onto the spindle shaft (Figure 65).

**Important:** The curved part of the blade must be pointing upward toward the inside of the mower to ensure proper cutting.

2. Install the spring disk and blade bolt. The spring disk cone must be installed toward the bolt head (Figure 65).

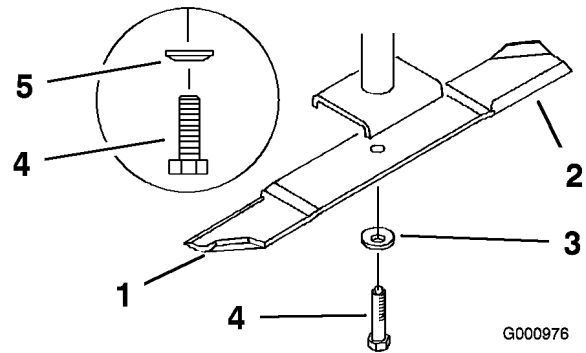

Figure 65

1. Sail Area of Blade
2. Blade
3. Spring Disk
4. Blade Bolt
5. Cone Towards Bolt Head

3. Torque the blade bolt to 85-110 ft-lb (115-150 N·m).

## Replacing the Grass Deflector



An uncovered discharge opening could allow the lawn mower to throw objects in the operator's or bystander's direction and result in serious injury. Also, contact with the blade could occur.

- Never operate the lawn mower unless you install a cover plate, a mulch plate, or a grass chute and catcher.
- Make sure the grass deflector is in the down position.

1. Remove the locknut, bolt, spring and spacer holding the deflector to the pivot brackets (Figure 66).

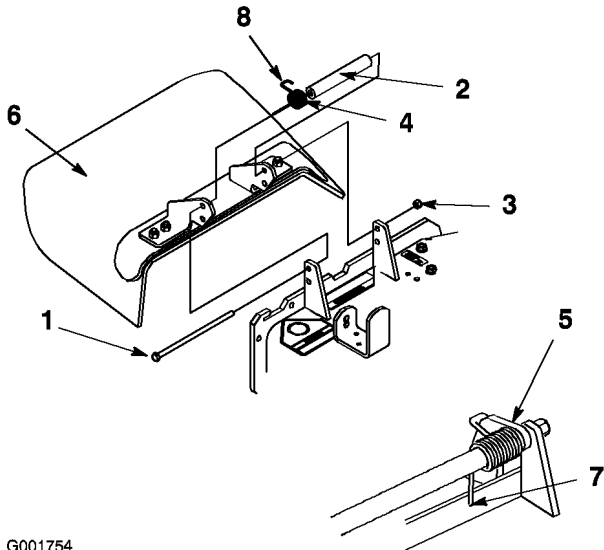

G001754

**Figure 66**

- |            |   |
|------------|---|
| 1. Bolt    | 5. Spring installed                                 |
| 2. Spacer  | 6. Grass Deflector                                  |
| 3. Locknut | 7. Place behind deck edge<br>before installing bolt |
| 4. Spring  | 8. Hook end of spring                               |

2. Remove the damaged or worn grass deflector.
3. Install the bolt and nut.
4. Place the **J** hook end of the spring around the grass deflector (Figure 66).

**Important:** The grass deflector must be able to lower down into position. Lift the deflector up to test that it lowers into the full down position.

## Cleaning

### Cleaning Under the Mower

Remove the grass buildup under the mower daily.

1. Disengage the PTO, move the motion control levers to the neutral locked position and set the parking brake.
2. Stop the engine, remove the key, and wait for all moving parts to stop before leaving the operating position.
3. Raise the mower to the transport position.

### Waste Disposal

Engine oil, batteries, hydraulic oil, and engine coolant are pollutants to the environment. Dispose of these according to your state and local regulations.

# Storage

1. Disengage the power take off (PTO), set the parking brake and turn the ignition key to off. Remove spark plug wire. Remove the key.
2. Remove grass clippings, dirt, and grime from the external parts of the entire machine, especially the engine and hydraulic system. Clean dirt and chaff from the outside of the engine's cylinder head fins and blower housing.

**Important:** You can wash the machine with mild detergent and water. Do not pressure wash the machine. Avoid excessive use of water, especially near the control panel, engine, hydraulic pumps and motors.

3. Service the air cleaner; refer to Servicing the Air Cleaner in Engine Maintenance, page 30.
4. Grease and oil the machine; refer to Greasing and Lubrication in Lubrication, page 28.
5. Change the crankcase oil; refer to Servicing the Engine Oil in Engine Maintenance, page 30.
6. Change the hydraulic filter; refer to Servicing the Hydraulic System in Hydraulic System Maintenance, page 42.
7. Check the tire pressure; refer to Checking the Tire Pressure in Drive System Maintenance, page 37.
8. Charge the battery; refer to Servicing the Battery in Electrical System Maintenance, page 34.
9. Scrape any heavy buildup of grass and dirt from the underside of the mower, then wash the mower with a garden hose.

**Note:** Run the machine with the PTO engaged and the engine at high idle for 2 to 5 minutes after washing.

10. Check the condition of the blades. Refer to Servicing the Cutting Blades.
11. Prepare the machine for storage when non-use occurs over 30 days. Prepare machine for storage as follows.
  - A. Add a petroleum based stabilizer/conditioner to fuel in the tank. Follow mixing instructions from

stabilizer manufacture. Do not use an alcohol based stabilizer (ethanol or methanol).

**Note:** A fuel stabilizer/conditioner is most effective when mixed with fresh gasoline and used at all times.

- B. Run engine to distribute conditioned fuel through the fuel system (5 minutes).
  - C. Stop engine, allow to cool and drain the fuel tank; refer to Servicing the Fuel Tank in Fuel System Maintenance, page 33.
  - D. Restart engine and run it until it stops.
  - E. Choke the engine. Start and run engine until it will not start.
  - F. Dispose of fuel properly. Recycle as per local codes.
- Important:** Do not store stabilizer/conditioned gasoline over 90 days.
12. Remove the spark plug(s) and check its condition; refer to Servicing the Spark Plug in Engine Maintenance, page 30. With the spark plug(s) removed from the engine, pour two tablespoons of engine oil into the spark plug hole. Now use the starter to crank the engine and distribute the oil inside the cylinder. Install the spark plug(s). Do not install the wire on the spark plug(s).
  13. Check and tighten all bolts, nuts, and screws. Repair or replace any part that is damaged or defective.
  14. Paint all scratched or bare metal surfaces. Paint is available from your Authorized Service Dealer.
  15. Store the machine in a clean, dry garage or storage area. Remove the key from the ignition switch and keep it out of reach of children or other unauthorized users. Cover the machine to protect it and keep it clean.

# Troubleshooting

<b>Problem</b>	<b>Possible Cause</b>	<b>Corrective Action</b>
Starter does not crank	<ol style="list-style-type: none"> <li>1. Blade control (PTO) is engaged.</li> <li>2. Parking brake is not on.</li> <li>3. Operator is not seated.</li> <li>4. Battery is dead.</li> <li>5. Electrical connections are corroded or loose.</li> <li>6. Fuse is blown.</li> <li>7. Relay or switch is defective.</li> </ol>	<ol style="list-style-type: none"> <li>1. Move blade contro (PTO) to disengaged.</li> <li>2. Set the parking brake.</li> <li>3. Sit on the seat.</li> <li>4. Charge the battery.</li> <li>5. Check the electrical connections for good contact.</li> <li>6. Replace fuse.</li> <li>7. Contact an Authorized Service Dealer.</li> </ol>
Engine will not start, starts hard, or fails to keep running.	<ol style="list-style-type: none"> <li>1. Fuel tank is empty.</li> <li>2. Air cleaner is dirty.</li> <li>3. Dirt in the fuel filter.</li> <li>4. Dirt, water, or stale fuel is in the fuel system.</li> </ol>	<ol style="list-style-type: none"> <li>1. Fill fuel tank with fuel.</li> <li>2. Clean or replace the air cleaner element.</li> <li>3. Replace the fuel filter.</li> <li>4. Contact an Authorized Service Dealer.</li> </ol>
Engine loses power.	<ol style="list-style-type: none"> <li>1. Engine load is excessive.</li> <li>2. Air cleaner is dirty.</li> <li>3. Oil level in the crankcase is low.</li> <li>4. Cooling fins and air passages above the engine are plugged.</li> <li>5. Vent hole in the fuel cap is plugged.</li> <li>6. Dirt in the fuel filter.</li> <li>7. Dirt, water, or stale fuel is in the fuel system.</li> </ol>	<ol style="list-style-type: none"> <li>1. Reduce the ground speed.</li> <li>2. Clean the air cleaner element.</li> <li>3. Add oil to the crankcase.</li> <li>4. Remove the obstruction from the cooling fins and air passages.</li> <li>5. Clean or replace the fuel cap.</li> <li>6. Replace the fuel filter.</li> <li>7. Contact an Authorized Service Dealer.</li> </ol>
Engine overheats.	<ol style="list-style-type: none"> <li>1. Engine load is excessive.</li> <li>2. Oil level in the crankcase is low.</li> <li>3. Cooling fins and air passages above the engine are plugged.</li> </ol>	<ol style="list-style-type: none"> <li>1. Reduce the ground speed.</li> <li>2. Add oil to the crankcase.</li> <li>3. Remove the obstruction from the cooling fins and air passages.</li> </ol>

<b>Problem</b>	<b>Possible Cause</b>	<b>Corrective Action</b>
Machine does not drive.	<ol style="list-style-type: none"> <li>1. By pass valve is not closed tight.</li> <li>2. Drive or pump belt is worn, loose or broken.</li> <li>3. Drive or pump belt is off a pulley.</li> <li>4. Broken or missing idler spring.</li> <li>5. Hydraulic fluid level is low or too hot.</li> </ol>	<ol style="list-style-type: none"> <li>1. Tighten the by pass valve.</li> <li>2. Change the belt.</li> <li>3. Change the belt.</li> <li>4. Replace the spring.</li> <li>5. Add hydraulic fluid to reservoir or let it cool down.</li> </ol>
Abnormal vibration.	<ol style="list-style-type: none"> <li>1. Cutting blade(s) is/are bent or unbalanced.</li> <li>2. Blade mounting bolt is loose.</li> <li>3. Engine mounting bolts are loose.</li> <li>4. Loose engine pulley, idler pulley, or blade pulley.</li> <li>5. Engine pulley is damaged.</li> <li>6. Blade spindle is bent.</li> <li>7. Motor mount is loose or worn.</li> </ol>	<ol style="list-style-type: none"> <li>1. Install new cutting blade(s).</li> <li>2. Tighten the blade mounting bolt.</li> <li>3. Tighten the engine mounting bolts.</li> <li>4. Tighten the appropriate pulley.</li> <li>5. Contact an Authorized Service Dealer.</li> <li>6. Contact an Authorized Service Dealer.</li> <li>7. Contact an Authorized Service Dealer.</li> </ol>
Uneven cutting height.	<ol style="list-style-type: none"> <li>1. Blade(s) not sharp.</li> <li>2. Cutting blade(s) is/are bent.</li> <li>3. Mower is not level.</li> <li>4. Underside of mower is dirty.</li> <li>5. Tire pressure is not correct.</li> <li>6. Blade spindle bent.</li> </ol>	<ol style="list-style-type: none"> <li>1. Sharpen the blade(s).</li> <li>2. Install new cutting blade(s).</li> <li>3. Level mower from side-to-side and front-to-rear.</li> <li>4. Clean the underside of the mower.</li> <li>5. Adjust the tire pressure.</li> <li>6. Contact an Authorized Service Dealer.</li> </ol>

<b>Problem</b>	<b>Possible Cause</b>	<b>Corrective Action</b>
Blades do not rotate.	<ol style="list-style-type: none"> <li>1. Drive belt is worn, loose or broken.</li> <li>2. Drive belt is off pulley.</li> <li>3. Deck belt is worn, loose or broken.</li> <li>4. Deck belt is off pulley.</li> <li>5. Broken or missing idler spring.</li> </ol>	<ol style="list-style-type: none"> <li>1. Check the belt tension.</li> <li>2. Install drive belt and check adjusting shafts and belt guides for correct position.</li> <li>3. Install new deck belt.</li> <li>4. Install deck pulley and check the idler pulley, idler arm and spring for correct position and function.</li> <li>5. Replace the spring.</li> </ol>

# Schematics

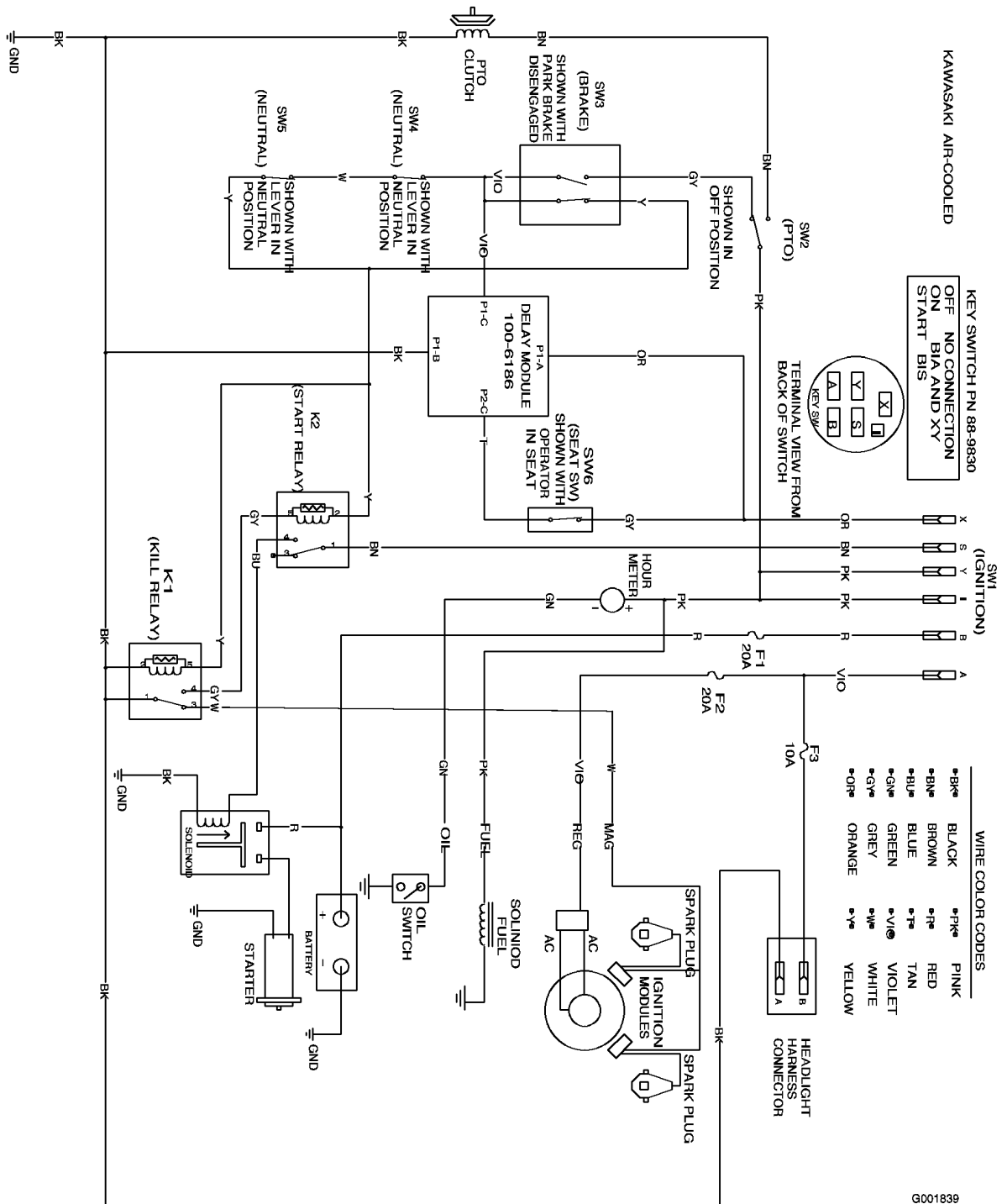

G001839

**Wire Diagram (Rev. A)**





## Evaporative Emission Control Warranty Statement

California Evaporative Emission Control Warranty Statement  
Your Warranty Rights and Obligations

### Introduction

The California Air Resources Board and The Toro® Company are pleased to explain the evaporative emission control system's warranty on your 2006 model year equipment. In California, new equipment that use small off-road engines must be designed, built, and equipped to meet the State's stringent anti-smog standards. The Toro® Company must warrant the evaporative emission control system on your equipment for two years provided there has been no abuse, neglect or improper maintenance of your equipment. Your evaporative emission control system may include parts such as: fuel lines, fuel line fittings, and clamps.

### Manufacturer's Warranty Coverage:

This evaporative emission control system is warranted for two years. If any evaporative emission-related part on your equipment is defective, the part will be repaired or replaced by The Toro® Company.

### Owner's Warranty Responsibilities:

- As the equipment owner, you are responsible for performance of the required maintenance listed in your Operator's Manual. The Toro® Company recommends that you retain all receipts covering maintenance on your equipment, but The Toro® Company cannot deny warranty solely for the lack of receipts.
- As the equipment owner, you should however be aware that The Toro® Company may deny you warranty coverage if your emission warranty parts have failed due to abuse, neglect, or improper maintenance or unapproved modifications.
- You are responsible for presenting your equipment to an Authorized Service Dealer as soon as the problem exists. The warranty repairs should be completed in a reasonable amount of time, not to exceed 30 days. If you have a question regarding your warranty coverage, you should contact The Toro® Company at 1-952-948-4027 or call us toll free at the number listed in your Toro Warranty statement.

### Defects Warranty Requirements:

1. The warranty period begins on the date the engine or equipment is delivered to an ultimate purchaser.
2. General Evaporative Emissions Warranty Coverage. The emission warranty parts must be warranted to the ultimate purchaser and any subsequent owner that the evaporative emission control system when installed was:
  - A. Designed, built, and equipped so as to conform with all applicable regulations; and
  - B. Free from defects in materials and workmanship that causes the failure of a warranted part for a period of two years.
3. The warranty on evaporative emissions-related parts will be interpreted as follows:
  - A. Any warranted part that is not scheduled for replacement as required maintenance in the written instructions must be warranted for the warranty period of two years. If any such part fails during the period of warranty coverage, it must be repaired or replaced by The Toro® Company. Any such part repaired or replaced under the warranty must be warranted for a time not less than the remaining warranty period.
  - B. Any warranted part that is scheduled only for regular inspection in the written instructions must be warranted for the warranty period of two years. A statement in such written instructions to the effect of "repair or replace as necessary" will not reduce the period of warranty coverage. Any such part repaired or replaced under warranty must be warranted for a time not less than the remaining warranty period.
  - C. Any warranted part that is scheduled for replacement as required maintenance in the written instructions must be warranted for the period of time prior to the first scheduled replacement point for that part. If the part fails prior to the first scheduled replacement, the part must be repaired or replaced by The Toro® Company. Any such part repaired or replaced under warranty must be warranted for a time not less than the remainder of the period prior to the first scheduled replacement point for the part.
  - D. Repair or replacement of any warranted part under the warranty provisions of this article must be performed at no charge to the owner at an Authorized Service Dealer.
  - E. Notwithstanding the provisions of subsection (D) above, warranty services or repairs must be provided at an Authorized Service Dealer.
  - F. The owner must not be charged for diagnostic labor that leads to the determination that a warranted part is in fact defective, provided that such diagnostic work is performed at an Authorized Service Dealer.
  - G. Throughout the evaporative emission control system's two year warranty period, The Toro® Company must maintain a supply of warranted parts sufficient to meet the expected demand for such parts.
  - H. Manufacturer approved replacement parts must be used in the performance of any warranty maintenance or repairs and must be provided without charge to the owner. Such use will not reduce the warranty obligations of The Toro® Company.
  - I. The use of any add-on or modified parts will be grounds for disallowing a warranty claim made in accordance with this article. The Toro® Company will not be liable under this Article to warrant failures of warranted parts caused by the use of an add-on or modified part.
  - J. The Toro® Company shall provide any documents that describe the warranty procedures or policies within five working days of request by the Air Resources Board.

### Emission Warranty Parts List:

The following lists includes the parts covered under this warranty:

- Fuel Lines
- Fuel Line Fittings
- Clamps



LCE

# The Toro Total Coverage Guarantee

A Limited Warranty

## Conditions and Products Covered

The Toro® Company and its affiliate, Toro Warranty Company, pursuant to an agreement between them, jointly promise to repair the listed Toro Products if defective in materials or workmanship. The following time periods apply from the date of purchase:

Products	Warranty Period
All Products	1 year
All Spindles	2 years (parts and labor; third year, parts only)
Engines/Hydraulic Systems* on the following: Outfront and Mid-Mount Z's ProLine Mid-Size Mowers Groundsmaster[Symbol_registersans] Riding Mowers Backpack Blowers	2 years
Deck Shells (32 <sup>2</sup> -72 <sup>2</sup> ) on the following: ProLine Mid-Size Mowers Mid-Mount Z's	2 years
Electric Clutch on 500 Series Mid-Mount Z's	2 years

This warranty includes the cost of parts and labor, but you must pay transportation costs.

This warranty applies to:

- Outfront and Mid-Mount Z's
- ProLine Mid-Size Mowers
- Groundsmaster Riding Mowers
- Turf Maintenance Equipment
- Debris Management Equipment

Some engines used on Toro LCE Products are warranted by the engine manufacturer.

## Instructions for Obtaining Warranty Service

If you think that your Toro Product contains a defect in materials or workmanship, follow this procedure:

1. Contact any Toro Authorized or Master Service Dealer to arrange service at their dealership. To locate a dealer convenient to you, access our website at [www.Toro.com](http://www.Toro.com). You may also call our Toro Customer Care Department toll free at 888-577-7466 (U.S. Customers) or 877-484-9255 (Canada customers).
2. Bring the product and your proof of purchase (sales receipt) to the Service Dealer.

If for any reason you are dissatisfied with the Service Dealer's analysis or with the assistance provided, contact us at:

## Owner Responsibilities

You must maintain your Toro Product by following the maintenance procedures described in the operator's manual. Such routine maintenance, whether performed by a dealer or by you, is at your expense.

## Items and Conditions Not Covered

There is no other express warranty except for special emission system coverage on some products. This express warranty does not cover the following:

- Cost of regular maintenance service or parts, such as filters, fuel, lubricants, tune-up parts, blade sharpening, brake and clutch adjustments.
- Any product or part which has been altered or misused or required replacement or repair due to normal wear, accidents, or lack of proper maintenance.
- Repairs necessary due to improper fuel, contaminants in the fuel system, or failure to properly prepare the fuel system prior to any period of non-use over three months.
- Pickup and delivery charges.

All repairs covered by this warranty must be performed by an Authorized Toro Service Dealer using Toro approved replacement parts.

## General Conditions

**Repair by an Authorized Toro Service Dealer is your sole remedy under this warranty.**

**Neither The Toro® Company nor Toro Warranty Company is liable for indirect, incidental or consequential damages in connection with the use of the Toro Products covered by this warranty, including any cost or expense of providing substitute equipment or service during reasonable periods of malfunction or non-use pending completion of repairs under this warranty.**

**Some states do not allow exclusions of incidental or consequential damages, or limitations on how long an implied warranty lasts, so the above exclusions and limitations may not apply to you.**

**All implied warranties of merchantability (that the product is fit for ordinary use) and fitness for use (that the product is fit for a particular purpose) are limited to the duration of the express warranty.**

**This warranty gives you specific legal rights, and you may also have other rights which vary from state to state.**

LCB Customer Service Department  
Toro Warranty Company  
8111 Lyndale Avenue South  
Bloomington, MN 55420-1196

## Countries Other than the United States or Canada

Customers who have purchased Toro products exported from the United States or Canada should contact their Toro Distributor (Dealer) to obtain guarantee policies for your country, province, or state. If for any reason you are dissatisfied with your Distributor's service or have difficulty obtaining guarantee information, contact the Toro importer. If all other remedies fail, you may contact us at Toro Warranty Company.