



Commercial Walk-Behind Mower Fixed Deck Pistol Grip Hydro with 36in TURBO FORCE[®] Cutting Unit

Model No. 30984 - 270000001 and up.

Parts Catalog

Ordering Replacement Parts

To order replacement parts, please supply the part number, the quantity, and the description of each part desired.

Understanding Reference Numbers

Each Identified part in an illustration has a reference number. The reference number for a part also appears in the parts list, along with other information about the part.

This catalog uses two special reference number formats, one to indicate parts in a service assembly and another to indicate the quantity of a given part in an illustration.

Service Assembly Reference Numbers

Parts in service assemblies have reference numbers in the form a:b. The a represents the reference number of the entire service assembly and the b represents a sequential number unique to each part within the service assembly.

For example, a wheel assembly might be identified by reference number 6, the tire by 6:1, the valve by 6:2, and the wheel by 6:3. When you order the assembly identified by reference number 6, you receive all parts identified by reference numbers 6:1, 6:2, and 6:3. However, you may also order any part individually. Reference numbers of this type appear in illustrations and in part lists.

Reference Numbers Indicating Quantity

In an illustration, if a reference number indicates more than one part, the reference number has the form nX y. The n represents the quantity of the part, the X is the multiplication symbol, and the y represents the reference number.

For example, in an illustration, the reference number 2X 37 means that two of the parts identified by reference number 37 are indicated.

Contents

Description	Page	Description	Page
Engine and Fuel Tank Assembly 3	Valve and Camshaft Assembly Kawasaki FH430V-CS25 22
Drive Assembly 4	Lubrication Equipment Assembly Kawasaki FH430V-CS25 23
Parking Brake Assembly 6	Cooling Equipment Assembly Kawasaki FH430V-CS25 24
Frame and Wheel Assembly 7	Electric Equipment Assembly Kawasaki FH430V-CS25 25
Hydraulic Assembly 8	Control Equipment Assembly Kawasaki FH430V-CS25 26
Pivot and Linkage Assembly 10	Carburetor Assembly Kawasaki FH430V-CS25 27
Handle and Control Assembly 11	Air Filter and Muffler Assembly Kawasaki FH430V-CS25 28
Control Handle Assembly No. 110-6907 13	Fuel Tank and Valve Assembly Kawasaki FH430V-CS25 29
Deck Assembly 14	Starter Assembly Kawasaki FH430V-CS25 30
Deck Assembly No. 110-4907 15	Label Assembly Kawasaki FH430V-CS25 31
Deflector Assembly No. 110-0790 16	Attachments and Accessories List 32
Sheave, Spindle and Blade Assembly 17		
Idler Assembly 18		
Caster Assembly 19		
Cylinder and Crankcase Assembly Kawasaki FH430V-CS25 20		
Piston and Crankshaft Assembly Kawasaki FH430V-CS25 21		

Part Description Abbreviations

Part descriptions in this catalog may include the following abbreviations.

AR. as required	HYD. hydraulic
ASM. assembly	LH. left hand
BBC. blade brake clutch	NI. nylon insert
CARR. carriage	NPTF. national pipe thread fine
DEG. degrees	PFH. phillips flat head
EXT. external	PPH. phillips pan head
FH. flat head	PPHTF. phillips pan head thread forming
GA. gauge	PRH. phillips round head
HD. heavy-duty	PTH. phillips truss head
HF. hex flange	PTO. power-take-off
HH. hex head	RH. right hand
HHF. hex head flange	ROPS. roll-over protection system
HHFTF. hex head flange thread forming	SFH. slotted fillister head
HJ. hex jam	SHH. slotted hex head
HLH. hex lag head	SHWH. slotted hex washer head
HOC. height-of-cut	SPH. slotted pan head
HSBH. hex socket button head	SQH. square head
HSFH. hex socket flat head	SRH. slotted round head
HSH. hex socket head	STD. standard
HWH. hex washer head	TAP. self tapping
HWHTF. hex washer head thread forming	TTH. torx truss head

Footnotes

- ❶ Not illustrated
- ❷ Obtain from your local Kawasaki dealer

- ❸ Not serviced separately

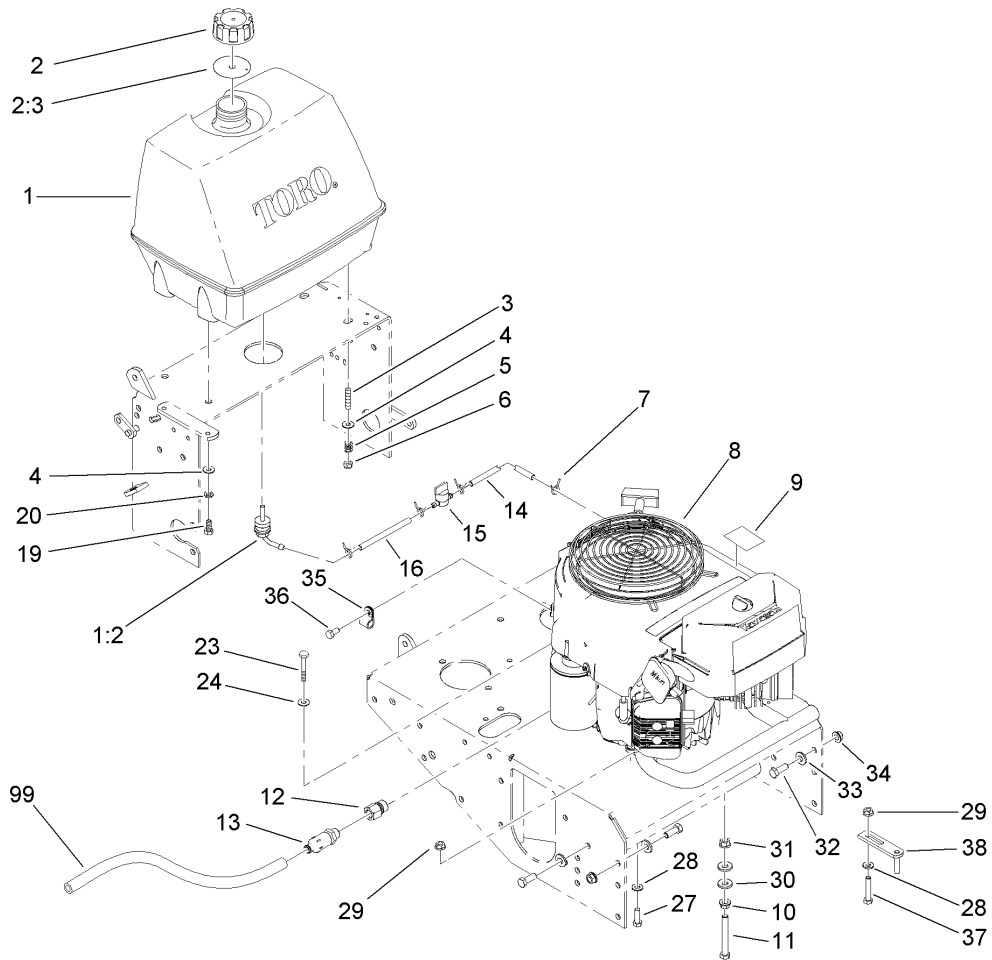

Engine and Fuel Tank Assembly

Ref	Part No.	Qty.	Description
1	106-0730	1	Fuel Tank ASM
1:2	103-2605	1	Fitting-Fuel, Bulkhead
2	88-3980	1	Gas Cap ASM
2:3	88-4010	1	Gasket-Cap, Gas
3	1-633023	2	Stud
4	3256-23	4	Washer-Flat
5	1-633349	2	Spring-Tank, Fuel
6	3296-47	2	Nut-Lock, NI
7	1-303077	4	Clamp
8		1	Engine-Kawasaki, FH430V-Cs25
9	106-0699	1	Decal-Warning
10	3290-357	1	Nut-HHF, Whiz
11	323-14	1	Screw-HH
12	103-1966	1	Adapter
13	92-6877	1	Valve-Drain, Oil
14	109-0293	1	Hose-Fuel
15	1-603770	1	Valve-Fuel
16	109-0306	1	Hose-Fuel
19	322-3	2	Screw-HH
20	1-805005	2	Washer-Lock
23	33113-016	1	Screw-HH
24	1-805004	1	Washer-Lock
27	322-7	3	Screw-HH
28	1-303334	4	Washer-Spring

Ref	Part No.	Qty.	Description
29	32128-20	4	Nut-HF
30	98-5975	2	Washer-Belleville
31	32128-21	1	Nut-HF
32	323-6	8	Screw-HH
33	98-5975	8	Washer-Belleville
34	3290-357	8	Nut-HHF, Whiz
35	1-413510	1	Clip-Loom
36	33114-016	1	Screw-HH
37	322-9	1	Screw-HH
38	1-322110	1	Guide-Belt
99	103-1964	1	Hose-Drain, Oil

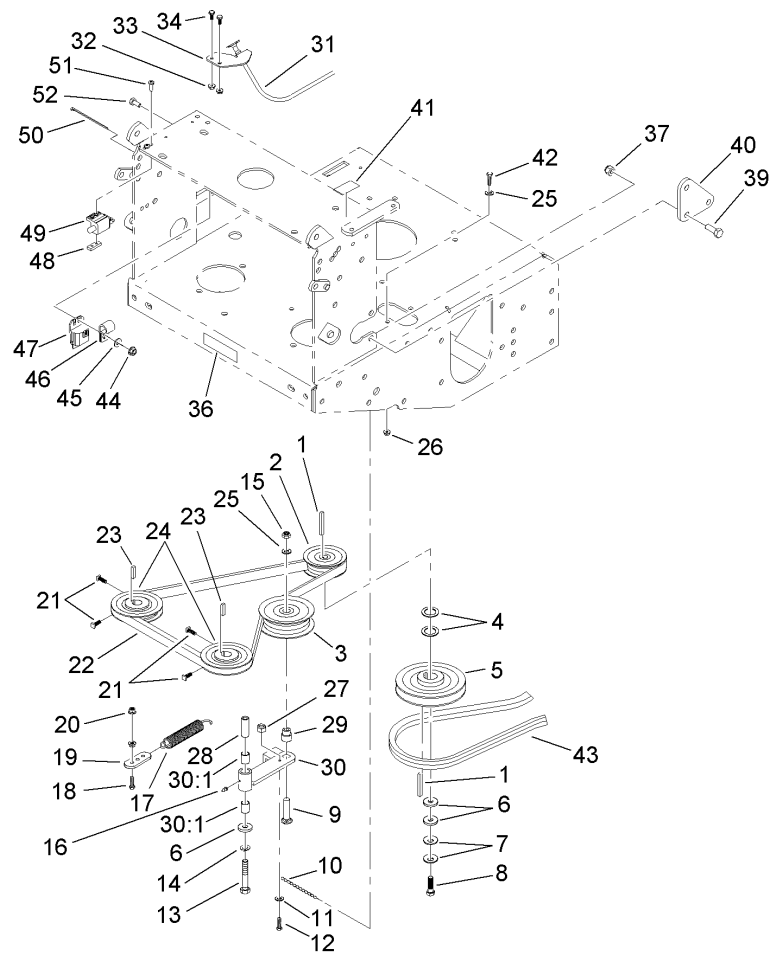

Drive Assembly

Ref	Part No.	Qty.	Description
1	1-807259	2	Key
2	1-653035	1	Pulley
3	1-603843	1	Pulley-Idler
4	1-523157	2	Washer-Spacer
5	110-4891	1	Pulley ASM
6	1-373034	3	Washer
7	1-603610	2	Washer-Spring
8	3212-6	1	Screw-HH
9	3231-29	1	Screw-CARR
10	1-323365	1	Chain-Link, Twist
11	3256-14	1	Washer-Flat
12	1-809069	1	Screw-HSH
13	323-12	1	Screw-HH
14	1-373034	1	Washer
15	32128-21	1	Nut-HF
16	302-19	1	Fitting-Grease
17	1-603402	1	Spring-Extension
18	322-5	1	Screw-HH
19	1-603801	1	Anchor-Spring
20	32128-20	2	Nut-HF
21	1-803050	4	Screw-Set
22	106-2740	1	V-Belt
23	1-807272	2	Key
24	1-413010	2	Sheave ASM

Ref	Part No.	Qty.	Description
25	3256-24	2	Washer-Flat
26	3290-357	1	Nut-HHF, Whiz
27	3296-2	1	Nut-Lock
28	1-603044	1	Bushing
29	1-603496	1	Bushing-Idler
30	1-602521	1	Idler Arm ASM
30:1	103-4681	2	Sleeve-Bearing
31	103-1796	1	Cable-Choke
32	32128-33	2	Nut-HF
33	103-1797-01	1	Bracket-Cable, Choke
34	321-3	2	Screw-HH
36	98-0776	1	Decal-Caution
37	3296-39	2	Nut-Lock, NI
39	323-6	2	Screw-HH
40	1-413497	1	Bellcrank
41	95-2814	1	Decal-Shut Off, Fuel
42	323-7	1	Screw-HH
43	108-6644	1	Belt-V
44	3296-42	1	Nut-Lock, NI
45	3256-22	1	Washer-Flat
46	1-603727	1	Clip-Loom
47	1-323430	1	Module-Interlock
48	1-633181	1	Plate-Tapped
49	1-513051	1	Switch-Open, Normally

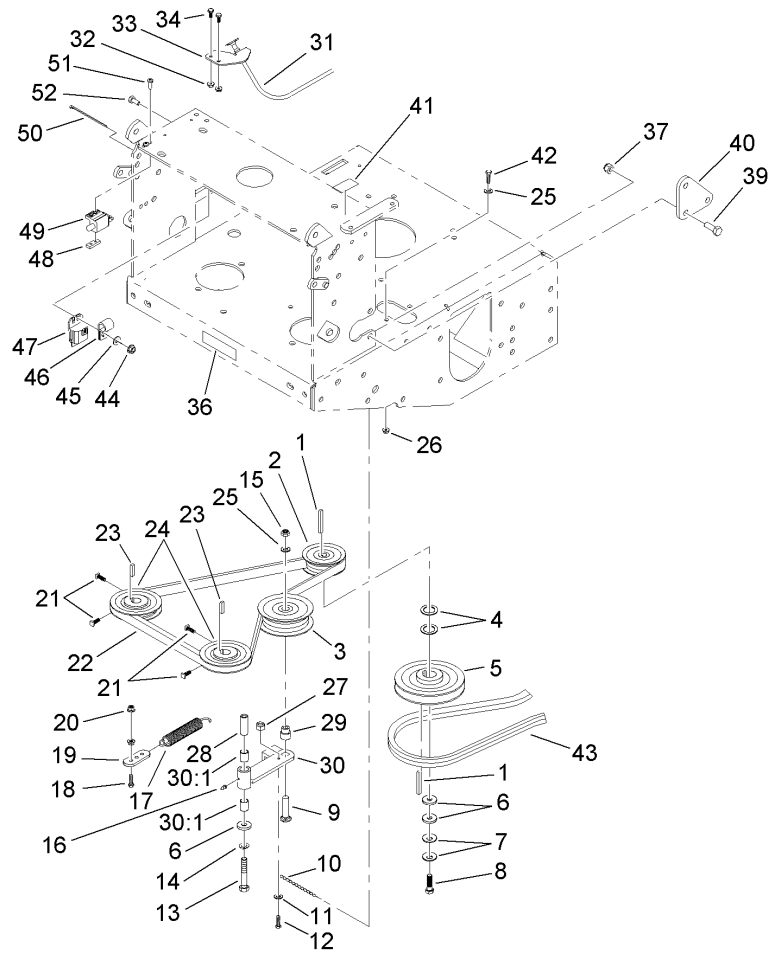

Drive Assembly (continued)

Ref	Part No.	Qty.	Description
50	1-303287	1	Tie-Plastic
51	3290-500	2	Screw-PPH
52	321-4	1	Screw-HH

--	--	--	--

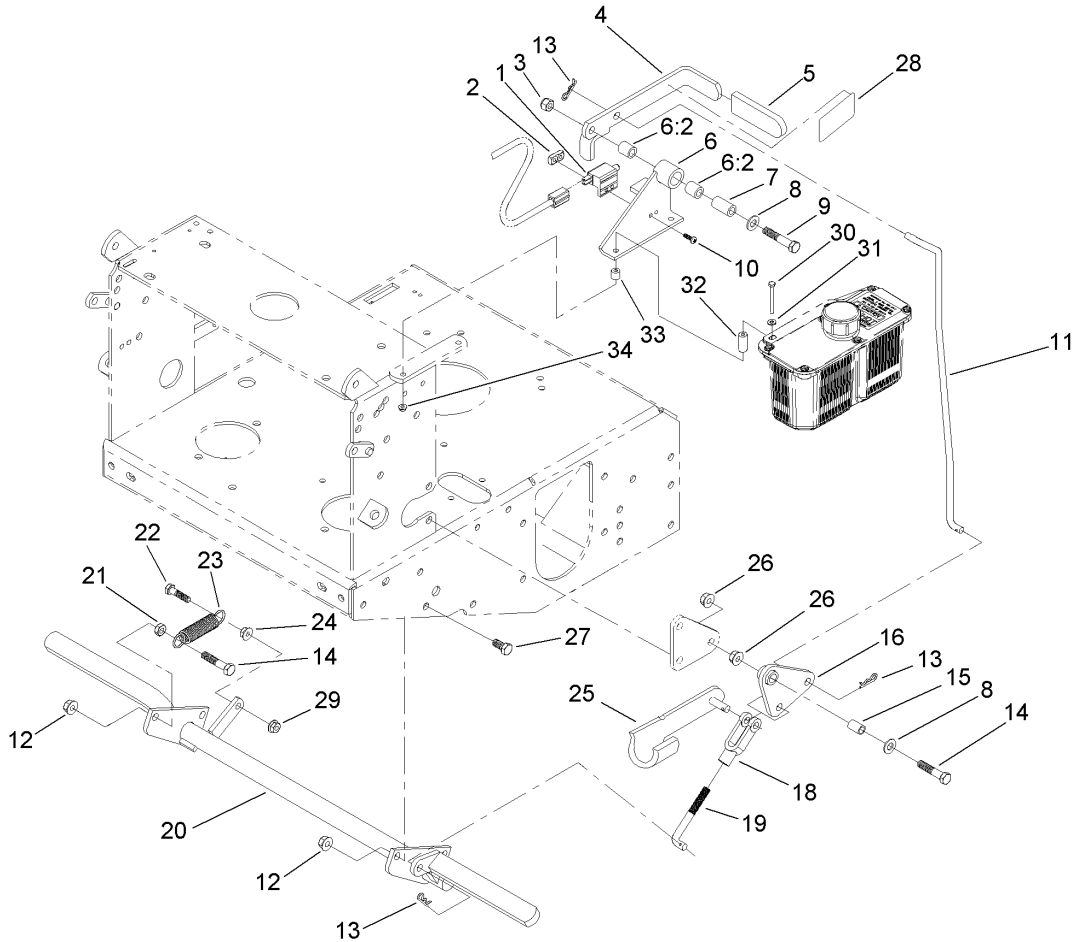

Parking Brake Assembly

Ref	Part No.	Qty.	Description
1	1-513051	1	Switch-Open, Normally
2	1-633181	1	Plate-Tapped
3	3296-39	1	Nut-Lock, NI
4	1-412501-03	1	Lever-Parkbrake
5	1-303020	1	Grip-Lever
6	1-414504	1	Bracket ASM
6:2	1-413347	2	Sleeve-Bushing
7	1-413344	1	Bushing-Pivot
8	3256-24	2	Washer-Flat
9	323-10	1	Screw-HH
10	3290-500	2	Screw-PPH
11	1-413496	1	Linkage-Upper
12	3296-39	4	Nut-Lock, NI
13	1-806003	3	Pin-Hair
14	323-9	2	Screw-HH
15	1-303548	1	Bushing-Plastic
16	1-414508	1	Bellcrank ASM
18	1-633131	1	Yoke-Linkage, Brake
19	1-413489	1	Linkage-Lower
20	103-2085-03	1	Brake ASM
21	3218-3	1	Nut-Jam
22	322-6	1	Screw-HH
23	1-323161	1	Spring-Idler
24	32128-20	1	Nut-HF

Ref	Part No.	Qty.	Description
25	103-2399	1	Pin-Spring, Clevis
26	32128-21	2	Nut-HF
27	323-6	3	Screw-HH
28	103-2103	1	Decal-Brake, Park
29	3296-29	1	Nut-Lock, NI
30	321-23	2	Screw-HH
31	3256-22	2	Washer-Flat
32	103-2191	2	Spacer
33	1-323549	2	Spacer
34	32128-33	2	Nut-HF

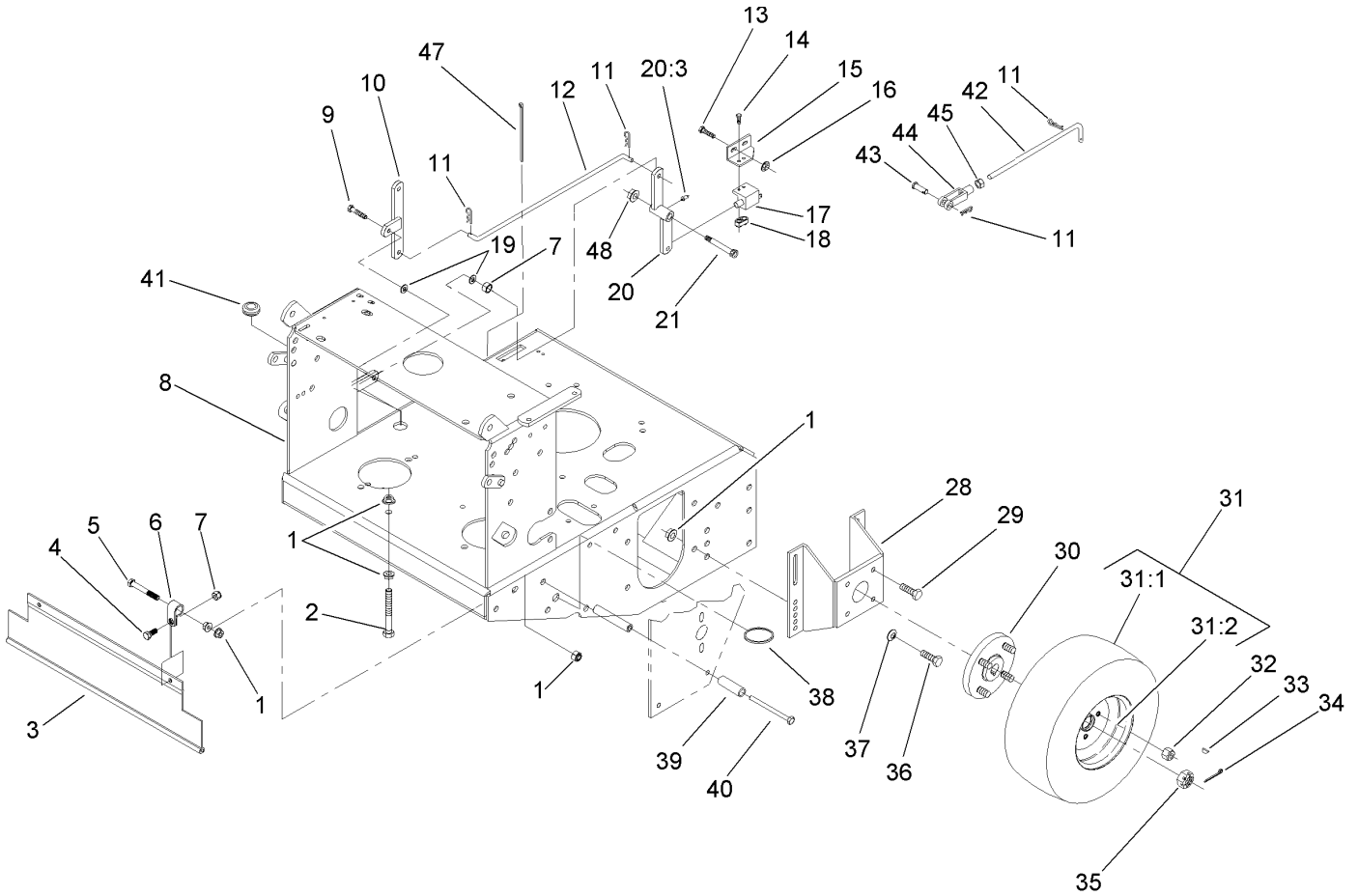

Frame and Wheel Assembly

Ref	Part No.	Qty.	Description
1	3290-357	15	Nut-HHF, Whiz
2	323-11	1	Screw-HH
3	103-2056	1	Shield-Drag
4	322-3	2	Screw-HH
5	323-13	2	Screw-HH
6	1-413510	2	Clip-Loom
7	3296-29	3	Nut-Lock, NI
8	110-6915-01	1	Hydro Frame ASM
9	322-6	1	Screw-HH
10	1-322090-01	1	Bellcrank ASM
11	1-806003	4	Pin-Hair
12	1-323172	1	Linkage-Engage, Blade
13	321-3	2	Screw-HH
14	3290-500	2	Screw-PPH
15	1-323213	1	Bracket-Switch, Blade
16	32128-33	2	Nut-HF
17	1-513051	1	Switch-Open, Normally
18	1-633181	1	Plate-Tapped
19	3256-23	2	Washer-Flat
20	1-322108	1	Bellcrank ASM
20:3	302-40	1	Fitting-Grease
21	1-809062	1	Screw
28	103-2289-01	2	Mount-Motor
29	3234-12	8	Screw-HHF

Ref	Part No.	Qty.	Description
30	1-602997	2	Hub W/Studs
31	1-413473	2	Wheel And Tire ASM
31:1	1-413474	1	Tire-Turfmaster
31:2	1-603715	1	Wheel-Rim
32	242-50	8	Nut-Lug
33	1-807019	2	Key-Woodruff
34	1-806800	2	Pin-Cotter
35	32136-5	2	Nut-Hex, Slotted
36	323-6	8	Screw-HH
37	98-5975	8	Washer-Belleville
38	1-323366	1	Ring-Split
39	105-4820	1	Spacer-Short
40	323-23	1	Screw-HH
41	1-543296	1	Grommet
42	1-323174	1	Arm-Linkage, Assist
43	1-808280	1	Pin-Clevis
44	1-303105	1	Yoke-Adjustable
45	3219-2	1	Nut-Hex
47	1-303287	2	Tie-Plastic
48	32128-21	1	Nut-HF

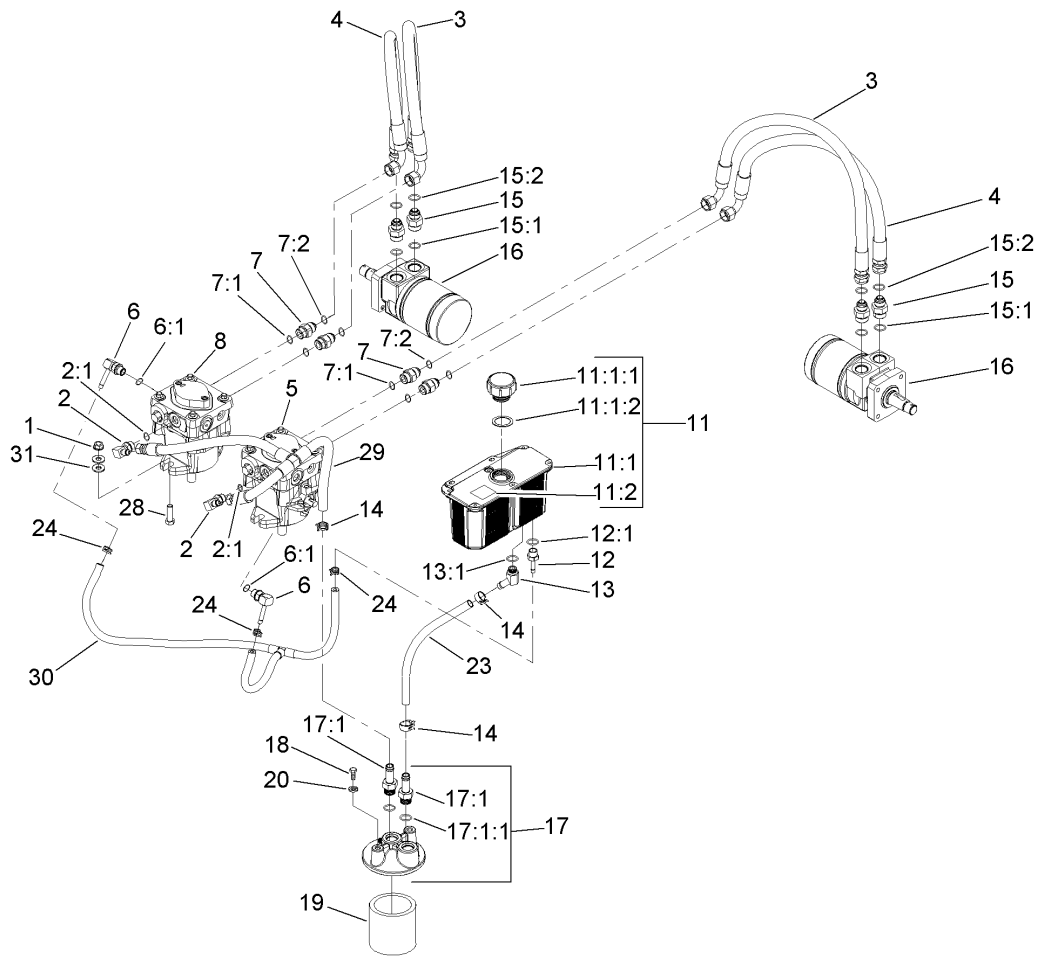

Hydraulic Assembly

Ref	Part No.	Qty.	Description
1	3290-357	4	Nut-HHF, Whiz
2	103-1802	2	Fitting-HYD, 90 DEG
2:1	1-603921	1	O-Ring
3	1-323241	2	Hose-Pressure, High
4	1-613034	2	Hose-Pressure, High
5	109-4987	1	Pump-HYD
●5:1	103-2664	1	Input Shaft Kit
●5:2	94-6922	1	Bearing-Thrust
●5:3	103-2666	1	Cylinder Block Kit
●5:4	105-6185	1	Plate-Valve
●5:5	105-6184	1	Overhaul Seal Kit
6	103-1799	2	Elbow-90 DEG
6:1	237-42	1	O-Ring
7	1-603990	4	Fitting-Straight
7:1	1-603920	1	O-Ring
7:2	1-603992	1	O-Ring
8	109-4988	1	Pump-HYD
●8:1	103-2664	1	Input Shaft Kit
●8:2	94-6922	1	Bearing-Thrust
●8:3	103-2666	1	Cylinder Block Kit
●8:4	105-6185	1	Plate-Valve
●8:5	105-6184	1	Overhaul Seal Kit
11	103-1947	1	HYD Reservoir ASM
●11:1		1	Reservoir-HYD

Ref	Part No.	Qty.	Description
11:1:1	103-1948	1	Cap-Reservoir, HYD
11:1:2	103-1949	1	Gasket-Cap
11:2	1-523552	1	Decal-Tank, HYD
12	103-1801	1	Adapter-Straight
12:1	237-42	1	O-Ring
13	103-1807	1	Elbow-45 DEG
13:1	237-42	1	O-Ring
14	103-1988	3	Clamp-Hose
15	1-603991	4	Fitting-Straight
15:1	237-80	1	O-Ring
15:2	1-603992	1	O-Ring
16	1-603718	2	Motor-Wheel
●16:1	1-000119	1	Seal Kit
17	103-2889	1	Filter Head ASM
17:1	103-1912	2	Adapter-Straight
17:1:1	237-42	1	O-Ring
18	321-3	2	Screw-HH
19	1-633750	1	Filter-Oil, HYD
20	1-805004	2	Washer-Lock
23	103-2959	1	Hose-Charge
24	103-1716	3	Clamp-Hose
28	323-7	4	Screw-HH
29	103-3914	1	Charge Hose ASM
30	103-4019	1	Case Drain Hose ASM

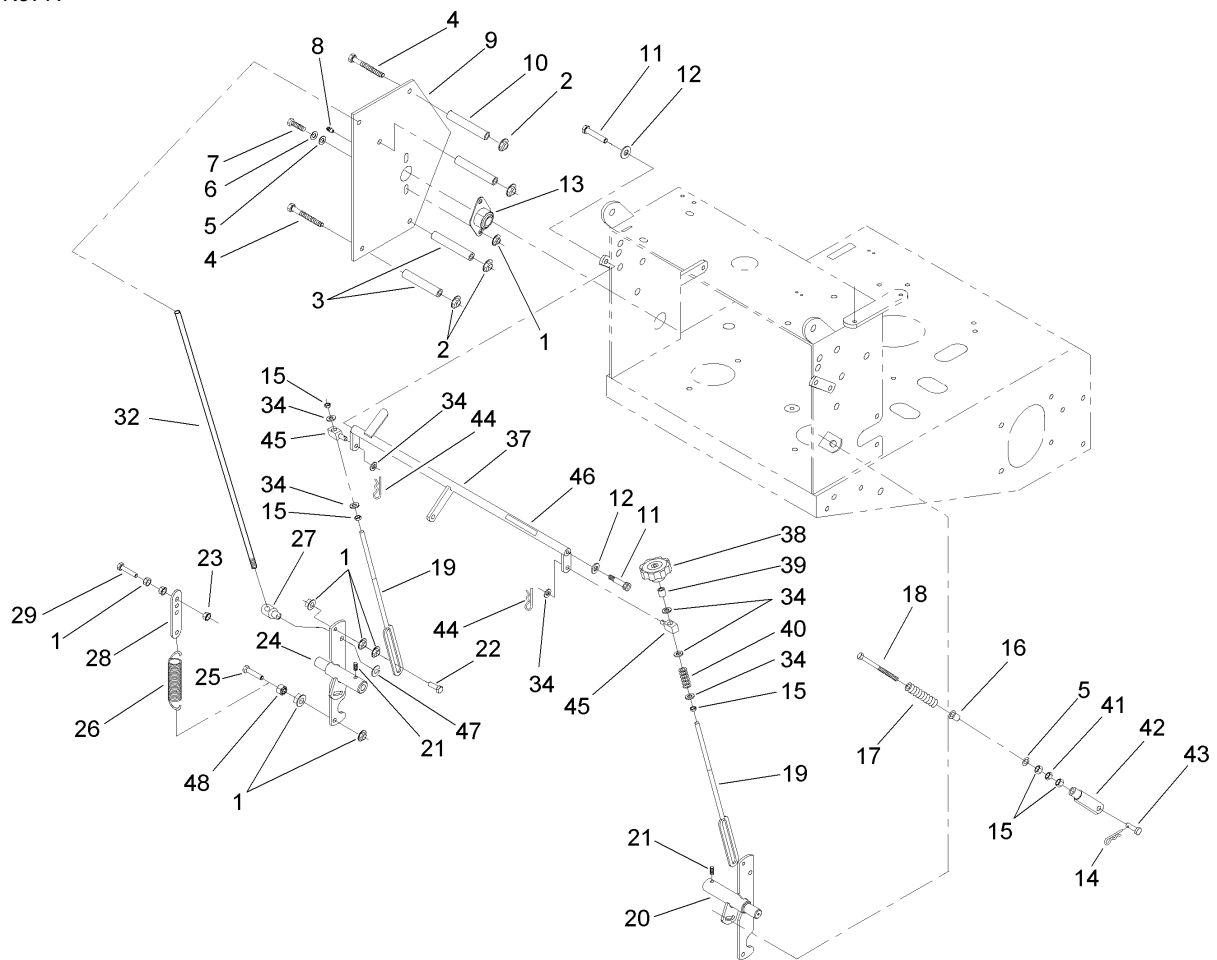

Pivot and Linkage Assembly

Ref	Part No.	Qty.	Description
1	32128-20	18	Nut-HF
2	3290-357	7	Nut-HHF, Whiz
3	1-323197-01	4	Spacer-Shield
4	323-16	7	Screw-HH
5	3256-2	6	Washer-Flat
6	1-805005	4	Washer-Lock
7	322-3	4	Screw-HH
8	302-19	2	Fitting-Grease
9	110-4897-01	2	Shield-Control, Hydro
10	1-323195-01	4	Spacer-Shield
11	1-809056	2	Screw
12	3256-24	2	Washer-Flat
13	1-633102	2	Bearing-Flange, Side
14	1-806003	2	Pin-Hair
15	3219-2	7	Nut-Hex
16	109-3769	2	Bushing-Nylon, Flanged
17	1-603807	2	Spring-Return, Neutral
18	1-603737	2	Bolt-Return, Neutral
19	1-413350	2	Link-Control, Speed
20	103-4796-01	1	Shaft-Control, RH
21	1-803022	2	Screw-Set
22	1-403180	2	Screw-HH
23	3296-29	2	Nut-Lock, NI
24	103-1190-01	1	Shaft-Control, LH

Ref	Part No.	Qty.	Description
25	322-6	2	Screw-HH
26	1-603693	2	Spring-Extension
27	103-1235	2	Swivel-Lever, Drive
28	1-613089	2	Tab-Spring, Extension
29	1-800016	2	Bolt-TAP, HH
32	1-413219	2	Rod-Lever, Drive
34	3256-23	7	Washer-Flat
37	1-412203-01	1	Crank-Control, Speed
38	1-413151	1	Knob-Tracking
39	1-603903	1	Spacer
40	1-323245	1	Spring-Compression
41	3220-2	2	Nut-Jam
42	1-303105	2	Yoke-Adjustable
43	1-808280	2	Pin-Clevis
44	3272-5	2	Pin-Cotter
45	1-603676	2	Swivel-Adjustable, Short
46	105-4109	1	Decal-Tracking
47	32151-47	2	Ring-Retaining
48	3218-2	2	Nut-Jam

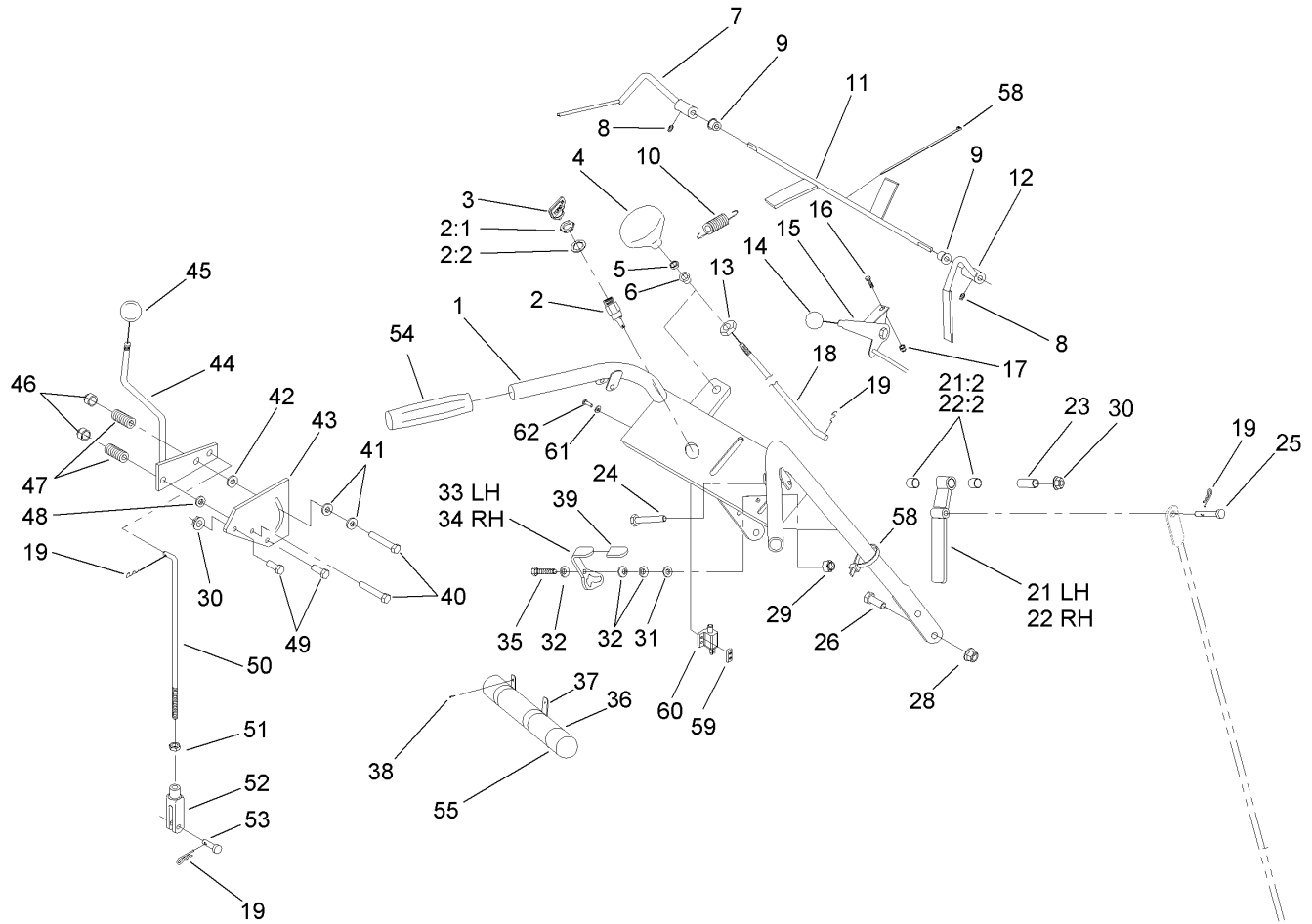

Handle and Control Assembly

Ref	Part No.	Qty.	Description
1	110-6907	1	Hydro Handle ASM
2	29-5560	1	Switch-On / Off
2:1	218-461	1	Nut-HH
2:2	3254-5	1	Washer-Tooth
3	63-8360	1	Key-Ignition
4	1-323134	1	Knob-Push / Pull
5	3218-2	1	Nut-Jam
6	1-323143	1	Bearing-Nylon
7	106-5485	1	LH Operator Presence Control Lever ASM
8	1-803322	2	Screw-Set
9	1-303365	2	Bushing-Nylon
10	1-303363	1	Spring-Extension
11	106-2717-03	1	Rod-Control, Operator Presence
12	106-5486	1	RH Operator Presence Control Lever ASM
13	1-323142	1	Nut-Push
14	1-513592	1	Knob-Ball
15	1-633696	1	Throttle Cable ASM
16	1-807513	2	Bolt-CARR
17	3296-2	2	Nut-Lock
18	1-323181	1	Linkage-Blade
19	1-806003	5	Pin-Hair
21	103-0218	1	LH Drive Lever ASM

Ref	Part No.	Qty.	Description
21:2	1-413152	2	Sleeve-Bushing
22	103-0219	1	RH Drive Lever ASM
22:2	1-413152	2	Sleeve-Bushing
23	1-603749	2	Bushing-Lever, Drive
24	321-9	2	Screw-HH
25	1-613055	2	Pin-Clevis
26	3234-11	4	Screw-HHF
28	32128-21	4	Nut-HF
29	3296-42	2	Nut-Lock, NI
30	32128-33	4	Nut-HF
31	3256-2	2	Washer-Flat
32	1-303435	6	Washer-Spring
33	1-612167	1	LH Grip / Latch ASM
34	1-612168	1	RH Grip / Latch ASM
35	321-10	2	Screw-HH
36	104-7050	1	Housing-Manual
37	2412-120	2	R-Clamp
38	32104-76	2	Screw
39	1-303019	2	Grip-Latch
40	322-10	2	Screw-HH
41	1-603716	1	Washer-Friction
42	1-323244	2	Washer-Friction
43	1-603730	1	Plate-Lever, Shifter
44	106-2748	1	Lever-Shift

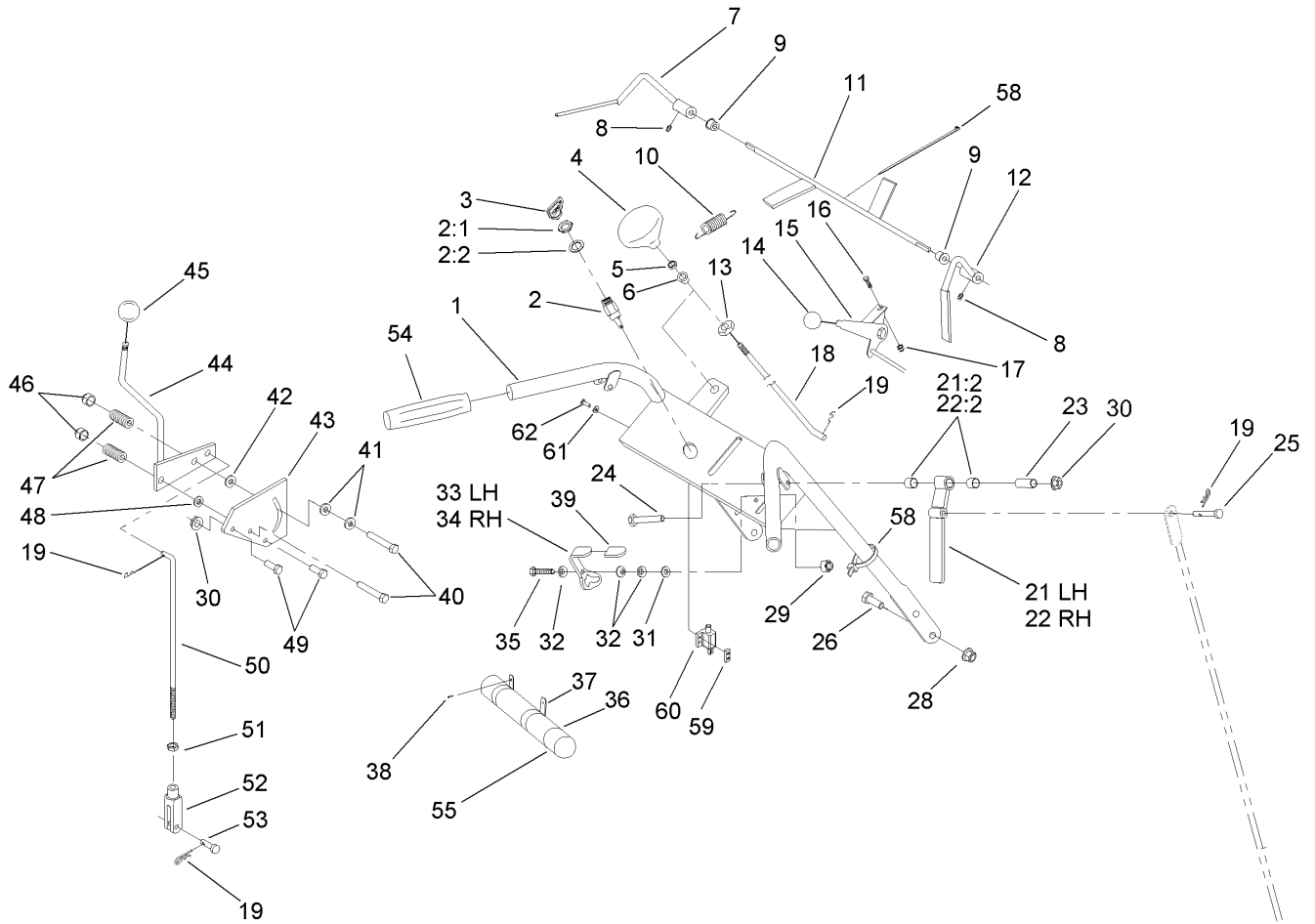

Handle and Control Assembly (continued)

Ref	Part No.	Qty.	Description
45	1-603175	1	Knob-Ball
46	3296-29	2	Nut-Lock, NI
47	1-323245	2	Spring-Compression
48	3256-23	1	Washer-Flat
49	321-3	2	Screw-HH
50	1-323522	1	Rod-Control, Speed
51	3220-2	1	Nut-Jam
52	1-303105	1	Yoke-Adjustable
53	1-808280	1	Pin-Clevis
54	104-9838	2	Grip-Foam
55	104-7048	1	Cap-Housing
58	1-303287	3	Tie-Plastic
59	1-633181	1	Plate-Tapped
60	1-513051	1	Switch-Open, Normally
61	3256-14	2	Washer-Flat
62	3290-500	2	Screw-PPH
●63	103-2007	1	Harness-Wiring

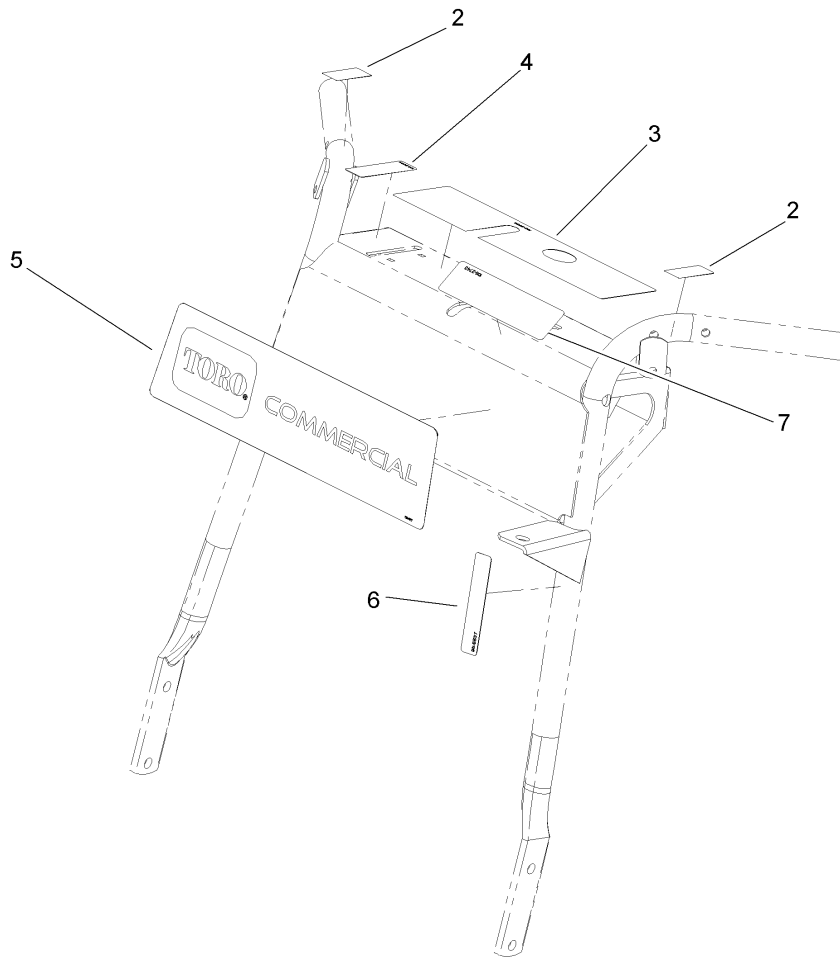

Control Handle Assembly No. 110-6907

Ref	Part No.	Qty.	Description				
2	105-4110	2	Decal-Lock, Neutral				
3	106-2738	1	Decal-Warning				
4	106-2733	1	Decal-Throttle				
5	110-6917	1	Decal				
6	95-5537	1	Decal-Engage, Deck				
7	106-2743	1	Decal-Caution, Brake				

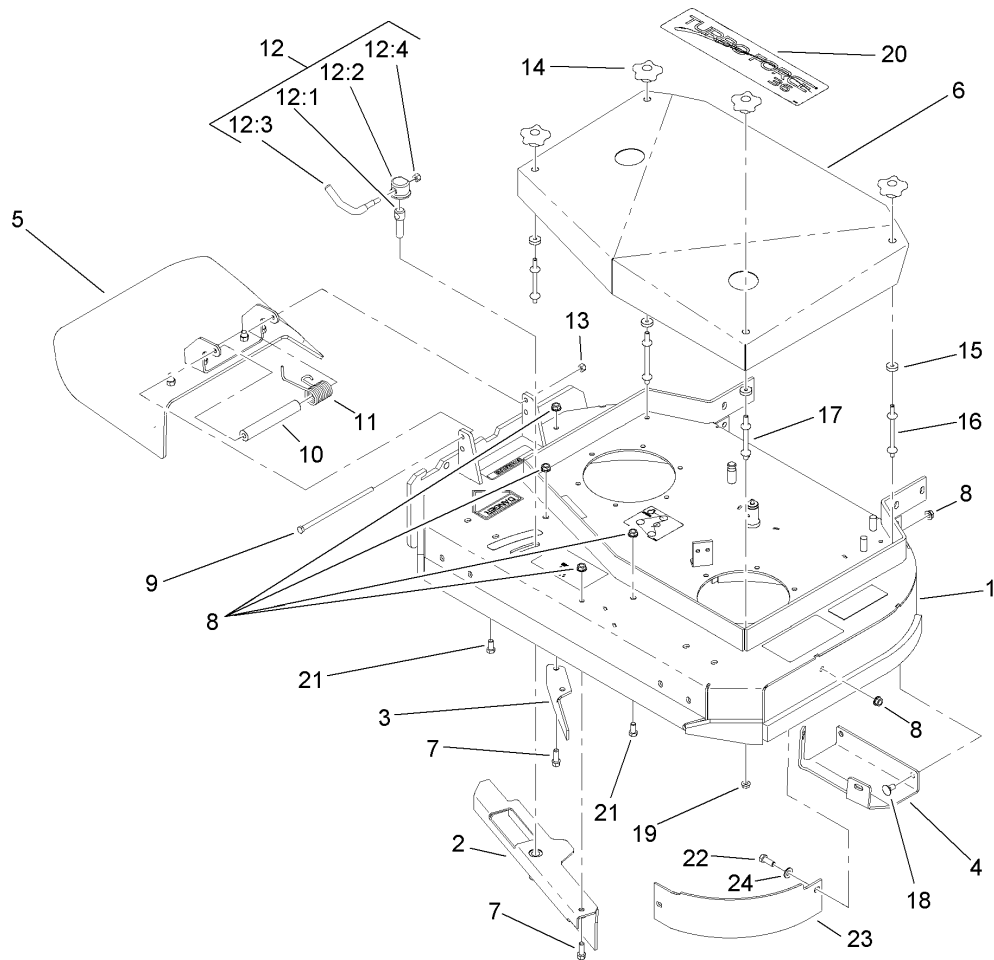

Deck Assembly

Ref	Part No.	Qty.	Description
1	110-4907	1	Deck ASM
2	110-2031-03	1	Baffle-Adjustable
3	110-0754-01	1	Baffle-Discharge
4	110-2037-01	1	Plate-Skid
5	110-0790	1	Deflector ASM
6	110-2036-01	1	Cover-Deck
7	92-1624	3	Screw
8	3290-357	10	Nut-HHF, Whiz
9	322-50	1	Screw-HH
10	105-4622	1	Spacer
11	104-8554	1	Spring-Torsion
12	107-1664	1	Lever ASM
12:1	106-3239	1	Screw-Lock
12:2	107-1644	1	Cap-Lock
12:3	106-3241	1	Lever-Lock
12:4	3296-29	1	Nut-Lock, NI
13	3296-29	1	Nut-Lock, NI
14	106-4161	4	Knob-Handle
15	1-323417	4	Washer
16	1-303536	2	Stud-Shield, Belt (Long)
17	1-303537	2	Stud-Shield, Belt (Short)
18	3231-1	4	Screw-CARR
19	32128-20	4	Nut-HF
20	110-6918	1	Decal

Ref	Part No.	Qty.	Description
21	323-4	2	Screw-HH
22	323-6	1	Screw-HH
23	110-6903-03	1	Baffle-Front, LH
24	3256-24	1	Washer-Flat

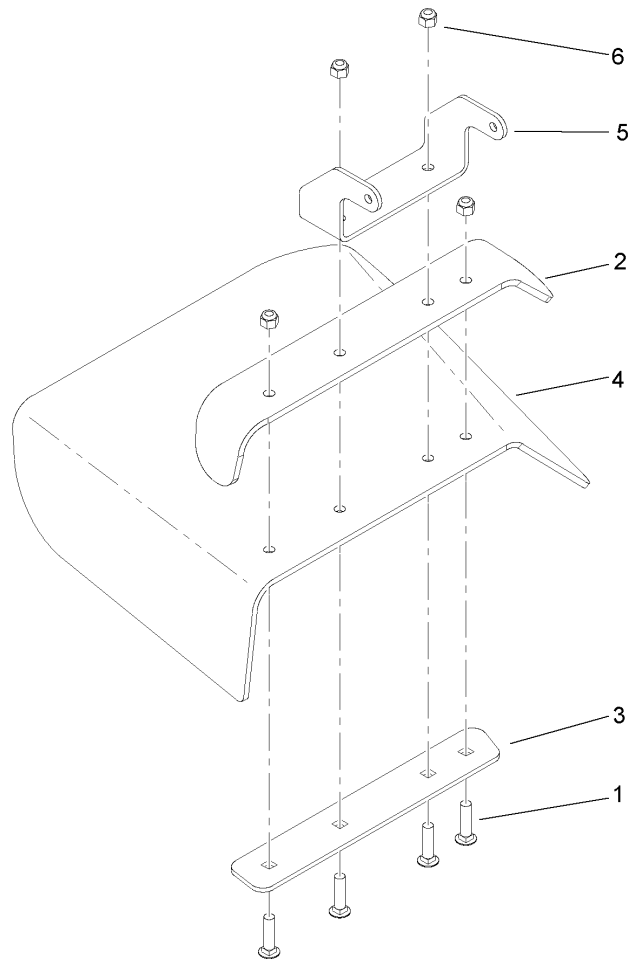

Deflector Assembly No. 110-0790

Ref	Part No.	Qty.	Description
1	3231-4	4	Screw-CARR
2	110-0792-01	1	Deflector
3	110-0793-03	1	Strap-Discharge
4	110-0791	1	Deflector-Rubber
5	107-4164-01	1	Bracket-Mounting, Deflector
6	3296-39	4	Nut-Lock, NI

--	--	--	--

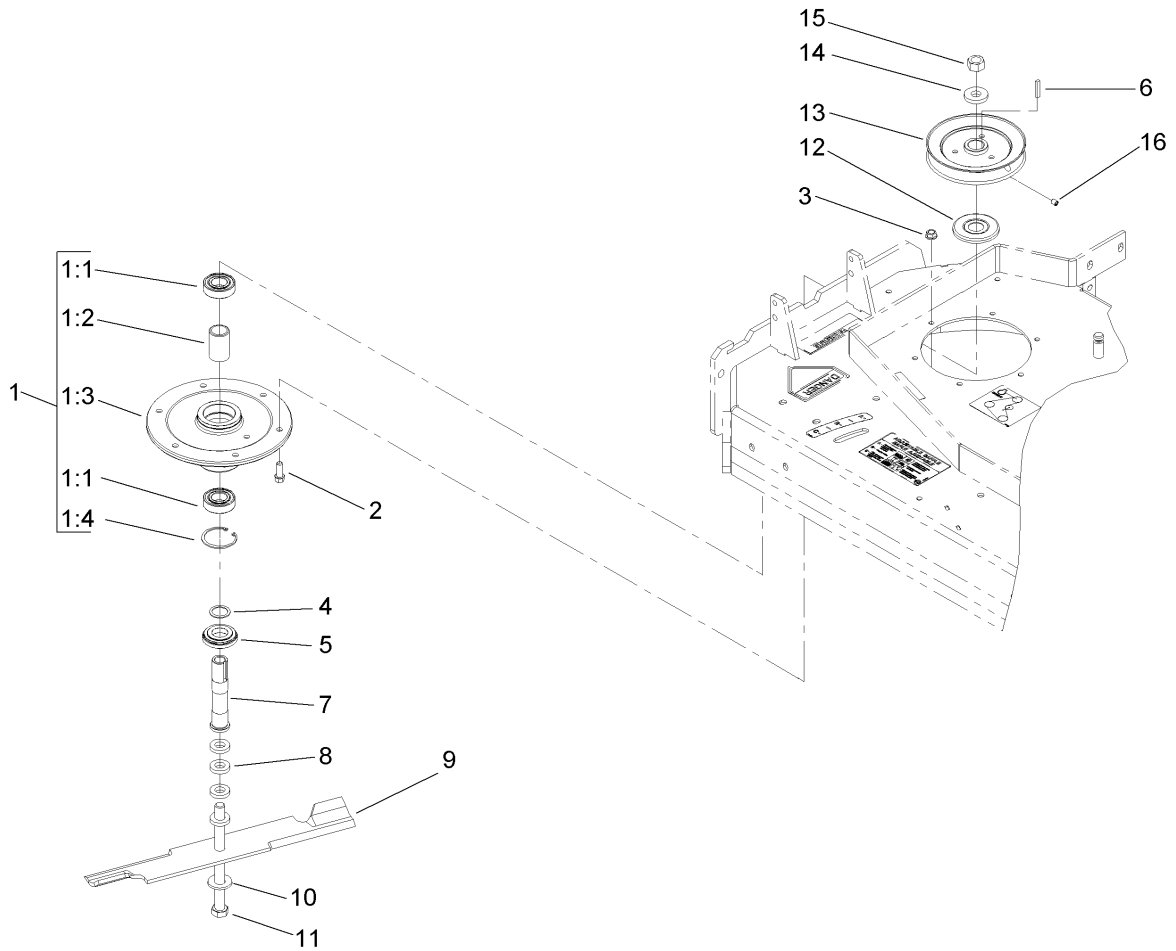

Sheave, Spindle and Blade Assembly

Ref	Part No.	Qty.	Description				
1	108-6697	2	Spindle Housing ASM				
1:1	110-2118	2	Bearing				
1:2	110-2116	1	Spacer-Bearing				
1:3	108-6694	1	Housing-Spindle				
1:4	32120-8	1	Ring-Snap				
2	92-1624	12	Screw				
3	3290-357	12	Nut-HHF, Whiz				
4	110-4888	2	Washer-Spacer				
5	103-2535	2	Spacer-Guard, Bottom				
6	1-807267	2	Key				
7	1-323529	2	Tube-Spindle, Short				
8	1-323539	8	Spacer				
9	105-7781-03	2	Blade-Hi Flow, 18 Inch				
10	1-513208	2	Washer-Spring				
11	1-800861	2	Screw-Cap, HH				
12	103-1330	2	Guard-Bearing, Top				
13	1-403183	2	Sheave				
14	1-323339	2	Washer-Retainer, Sheave				
15	3219-6	2	Nut-Hex				
16	1-803310	2	Screw-Set				

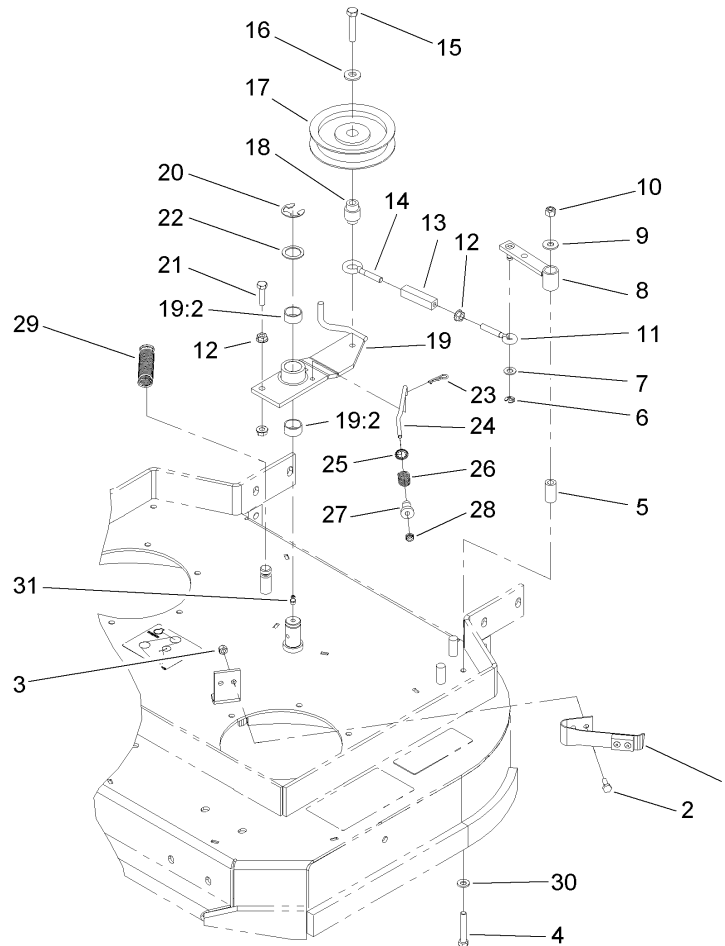

Idler Assembly

Ref	Part No.	Qty.	Description
1	1-324372	1	Pad And Spring ASM
2	321-4	2	Screw-HH
3	3296-42	2	Nut-Lock, NI
4	322-10	1	Screw-HH
5	1-403179	1	Tube-Pivot
6	32120-35	1	Ring-Retaining, EXT
7	3256-23	1	Washer-Flat
8	1-322235	1	Arm-Assist
9	3256-3	1	Washer-Flat
10	3296-29	1	Nut-Lock, NI
11	1-303238	1	Eyebolt-Thread, RH
12	32128-20	3	Nut-HF
13	1-303236	1	Body-Turnbuckle
14	1-303348	1	Eyebolt-Thread, LH
15	702809	1	Screw-Cap
16	98-5975	1	Washer-Belleville
17	1-603843	1	Pulley-Idler
18	1-303434	1	Bushing-Engagement
19	103-3600	1	Idler Arm ASM
19:2	1-323729	2	Sleeve-Bearing
20	32151-103	1	Ring-Snap
21	322-6	1	Screw-HH
22	1-303352	1	Washer-Spindle
23	1-806003	1	Pin-Hair

Ref	Part No.	Qty.	Description
24	1-323715	1	Rod-Brake
25	1-323748	1	Ring-Push On
26	1-323747	1	Spring-Compression
27	1-323746	1	Spacer-Flanged
28	3296-56	1	Nut-Lock, NI
29	1-323071	1	Spring-Extension
30	1-303334	1	Washer-Spring
31	302-19	2	Fitting-Grease

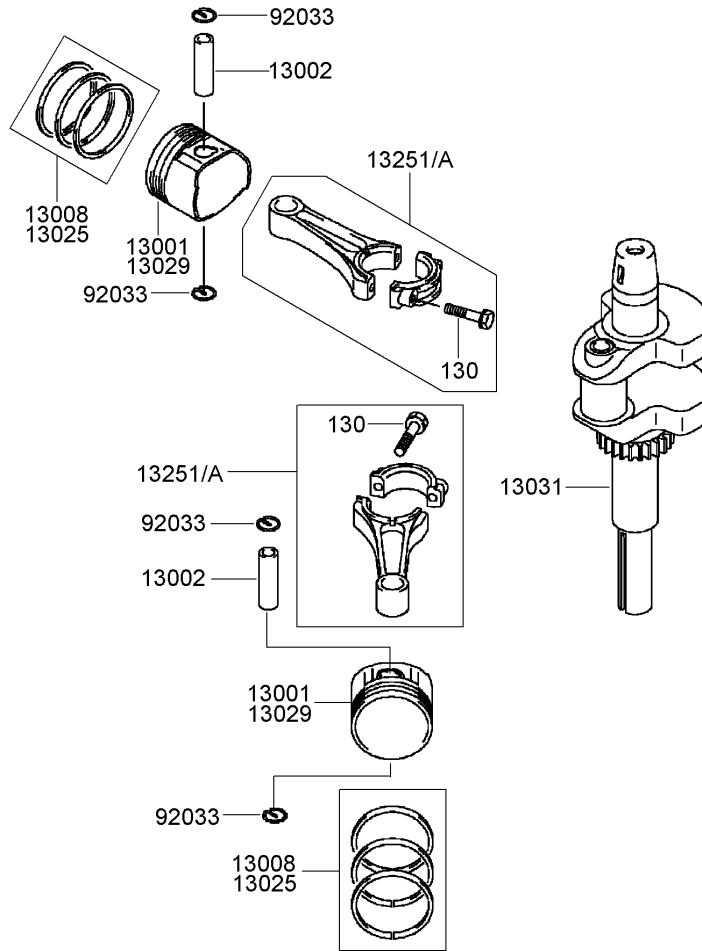

Piston and Crankshaft Assembly Kawasaki FH430V-CS25

Ref	Part No.	Qty.	Description
① 13001	13001-7009	2	Piston-Engine
① 13002	13002-7001	2	Pin-Piston
① 13008	13008-7001	2	Ring Set-Piston
① 13025	13025-7003	1	Ring Set-Piston (L 0.50)
① 13029	13029-7005	1	Piston-Engine (L 0.50)
① 13031	13031-7033	1	Crankshaft
① 13251	13251-7007	2	Connecting Rod ASM
① 13251A	13251-7008	2	Connecting Rod ASM (0.50)
① 92033	92033-7005	4	Ring-Snap
① 130	130G0630	4	Bolt-Flanged (6X30)

--	--	--	--

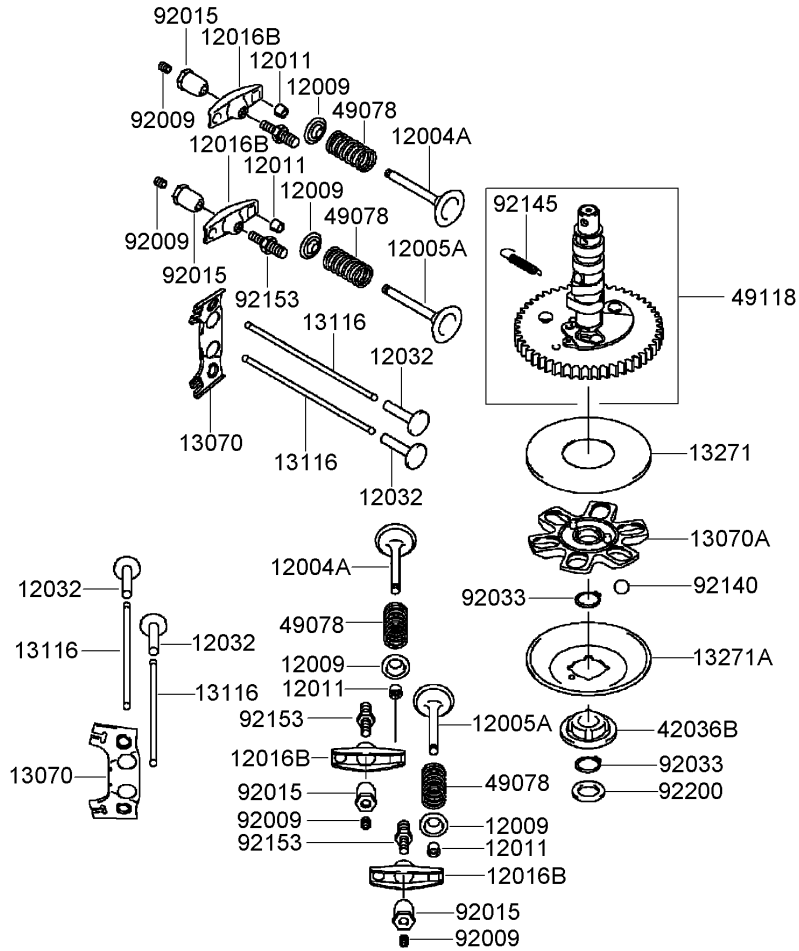

Valve and Camshaft Assembly Kawasaki FH430V-CS25

Ref	Part No.	Qty.	Description
③	12004A	2	Valve-Intake
③	12005A	2	Valve-Exhaust
③	12009	4	Retainer-Spring, Valve
③	12011	8	Collet
③	12016B	4	Arm-Rocker
③	12032	4	Tappet
③	13070	2	Guide
③	13070A	1	Guide
③	13116	4	Rod-Push
③	13271	1	Plate
③	13271A	1	Plate-Governor
③	42036B	1	Sleeve
③	49078	4	Spring-Valve, Engine
③	49118	1	Camshaft
③	92009	4	Screw
③	92015	4	Nut
③	92033	2	Ring-Snap
③	92140	6	Ball
③	92145	1	Spring
③	92153	4	Bolt
③	92200	1	Washer

--	--	--	--

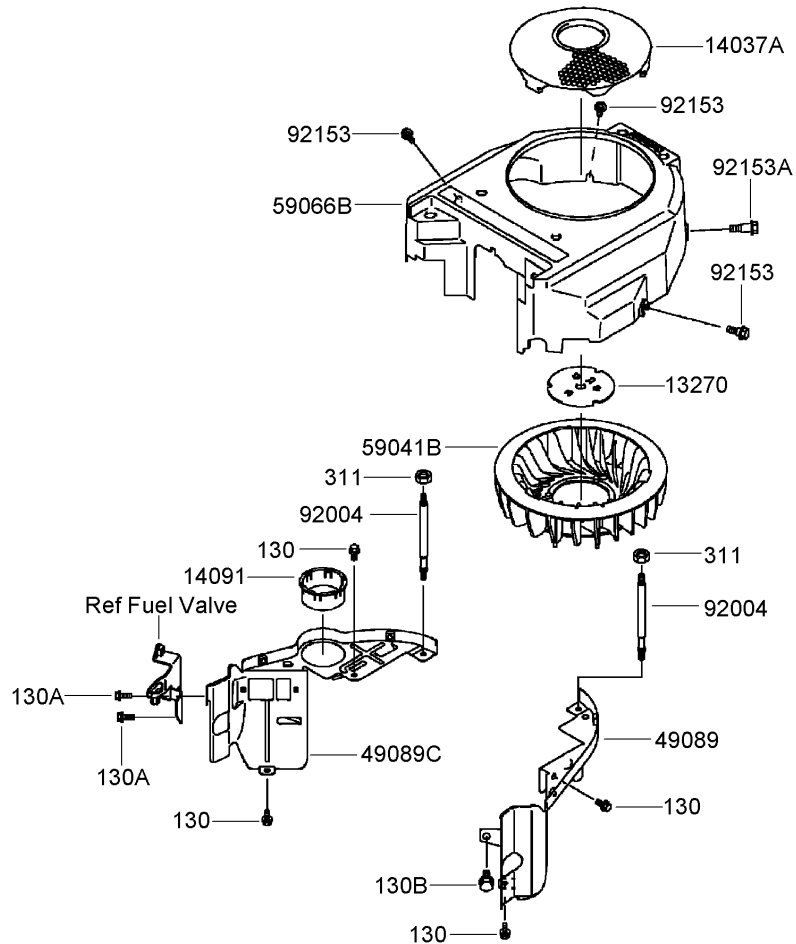

Cooling Equipment Assembly Kawasaki FH430V-CS25

Ref	Part No.	Qty.	Description
③ 13270	13270-7007	1	Plate
③ 14037A	14037-7025-9H	1	Screen
③ 14091	14091-7009	1	Cover
③ 49089	49089-7044	1	Shroud-Engine
③ 49089C	49089-7061	1	Shroud-Engine
③ 59041B	59041-7012	1	Fan
③ 59066B	59066-7036	1	Housing-Fan
③ 92004	92004-7007	2	Stud
③ 92153	92153-7007	3	Bolt
③ 92153A	92153-7008	1	Bolt
③ 130	130B0612	4	Bolt-Flanged (6X12)
③ 130A	130B0616	2	Bolt-Flanged (6X16)
③ 130B	130B0816	1	Bolt-Flanged (8X16)
③ 311	311F0600	2	Nut-Hex (6Mm)

--	--	--	--

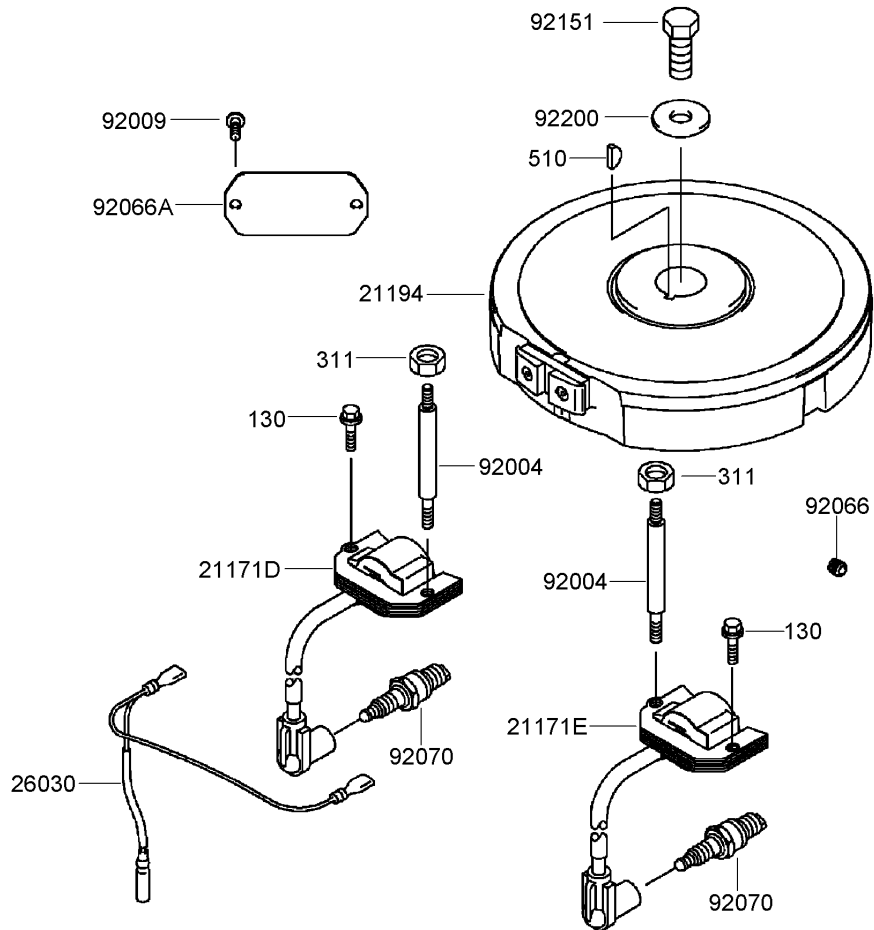

Electric Equipment Assembly Kawasaki FH430V-CS25

Ref	Part No.	Qty.	Description
③21171D	21171-7026	1	Coil-Assy-Ignition
③21171E	21171-7027	1	Coil-Assy-Ignition
③21194	21194-7013	1	Flywheel
③26030	26030-7001	1	Harness
③92004	92004-7008	2	Stud
③92009	92009-2308	2	Screw
③92066	92066-7002	1	Plug
③92066A	92066-7005	1	Plug
③92070	92070-7003	2	Plug-Spark (R C J 8 Y, Solid)
③92151	92151-2097	1	Bolt (12X30)
③92200	92200-7002	1	Washer
③130	130B0620	2	Bolt-Flanged (6X20)
③311	311F0600	2	Nut-Hex (6Mm)
③510	510A5100	1	Key-Woodruff

--	--	--	--

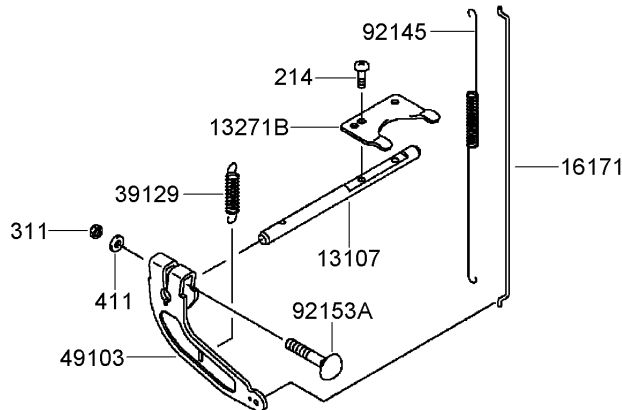
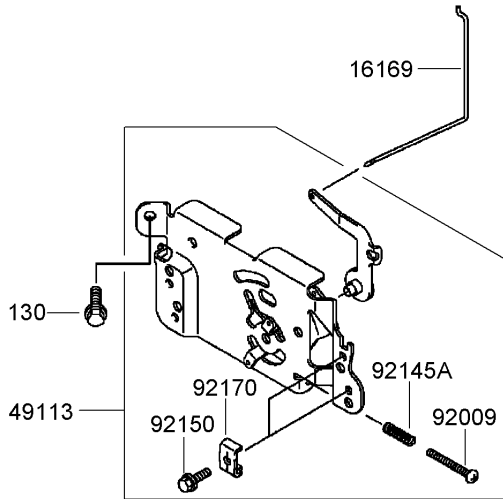

Control Equipment Assembly Kawasaki FH430V-CS25

Ref	Part No.	Qty.	Description				
③13107	13107-7010	1	Shaft				
③13271B	13271-7032	1	Plate				
③16169	16169-7012	1	Link-Choke				
③16171	16171-7007	1	Link				
③39129	39129-7003	1	Spring-Governor				
③49103	49103-7004	1	Arm-Governor				
③49113	49113-7024	1	Panel-Control				
③92009	92009-7007	1	Screw (4X35)				
③92145	92145-7003	1	Spring				
③92145A	92145-7005	1	Spring				
③92150	92150-2182	2	Bolt (5X18)				
③92153A	92153-7033	1	Bolt (6X35)				
③92170	92170-7001	2	Clamp				
③130	130B0612	2	Bolt-Flanged (6X12)				
③214	214B0408	2	Screw-Pan (4X8)				
③311	311B0600	1	Nut-Hex (6Mm)				
③411	411B0600	1	Washer-Plain (6Mm)				

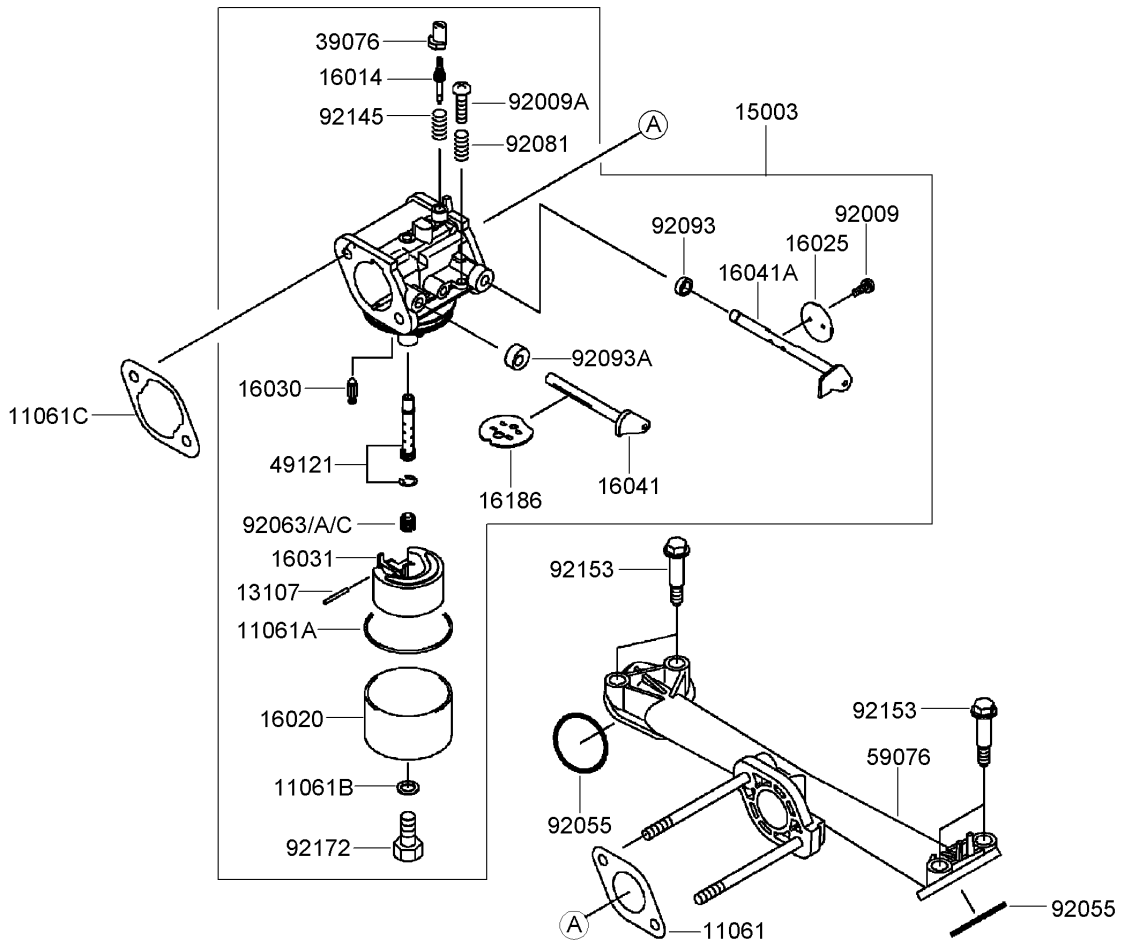

Carburetor Assembly Kawasaki FH430V-CS25

Ref	Part No.	Qty.	Description
● 11061	11061-7004	1	Gasket-Insulator
● 11061A	11061-7009	1	Gasket-Chamber
● 11061B	11061-7010	1	Gasket-Screw
● 11061C	11061-7018	1	Gasket-Cleaner, Air
● 13107	13107-7018	1	Shaft
● 15003	15003-7061	1	Carburetor ASM
● 16014	16014-7002	1	Screw-Pilot
● 16020	16020-7003	1	Chamber-Float
● 16025	16025-7006	1	Valve-Throttle
● 16030	16030-7003	1	Valve-Float
● 16031	16031-7002	1	Float
● 16041	16041-7016	1	Shaft-Choke, Carburetor
● 16041A	16041-7018	1	Shaft-Throttle, Carburetor
● 16186	16186-7002	1	Choke Valve ASM
● 39076	39076-7001	1	Limiter
● 49121	49121-7001	1	Nozzle-Main
● 59076	59076-7005	1	Manifold-Intake
● 92009	92009-2083	2	Screw
● 92009A	92009-2349	1	Screw
● 92055	92055-7007	2	O-Ring (I D 31)
● 92063	92063-7026	1	Jet-Main, No. 88
● 92063A	92063-7028	1	Jet-Main, No. 85
● 92063C	92063-7029	1	Jet-Main, No. 82
● 92081	92081-2234	1	Spring

Ref	Part No.	Qty.	Description
● 92093	92093-2100	1	Seal
● 92093A	92093-7003	1	Seal
● 92145	92145-7015	1	Spring
● 92153	92153-7009	4	Bolt
● 92172	92172-7002	1	Screw

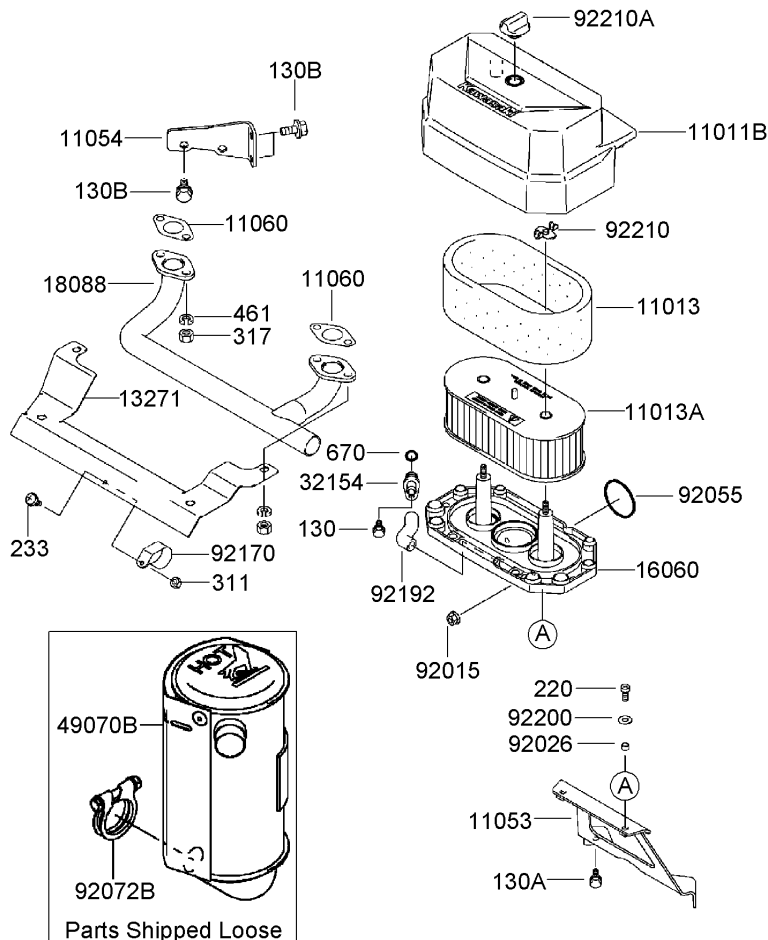

Air Filter and Muffler Assembly Kawasaki FH430V-CS25

Ref	Part No.	Qty.	Description
③11011B	11011-7045	1	Case-Filter, Air
③11013	11013-7025	1	Element-Filter, Air
③11013A	11013-7031	1	Element-Filter, Air
③11053	11053-7022	1	Bracket
③11054	11054-7002-9H	1	Bracket
③11060	11060-7021	2	Gasket-Muffler
③13271	13271-7022	1	Plate
③16060	16060-7016	1	Pipe-Intake
③18088	18088-7001	1	Pipe-Exhaust
③32154	32154-7006	1	Pipe
③49070B	49070-7021	1	Muffler
③92015	92015-1193	2	Nut
③92026	92026-7001	2	Spacer (6.2X7.9X5)
③92055	92055-7015	1	O-Ring
③92072B	92072-7012	1	Band
③92170	92170-7002	1	Clamp
③92192	92192-7010	1	Tube
③92200	92200-2070	2	Washer
③92210	92210-7004	2	Nut
③92210A	92210-7019	1	Nut
③130	130B0610	1	Bolt-Flanged (6X10)
③130A	130B0612	2	Bolt-Flanged (6X12)
③130B	130B0816	3	Bolt-Flanged (8X16)

Ref	Part No.	Qty.	Description
③220	220B0614	2	Screw-Pan (Cross) (6X14)
③233	233B0416	1	Screw (4X16)
③311	311B0400	1	Nut-Hex (4Mm)
③317	317R0800	4	Nut-Hex (8Mm)
③461	461F0800	4	Washer-Spring (8Mm)
③670	670B2010	1	O-Ring (10Mm)

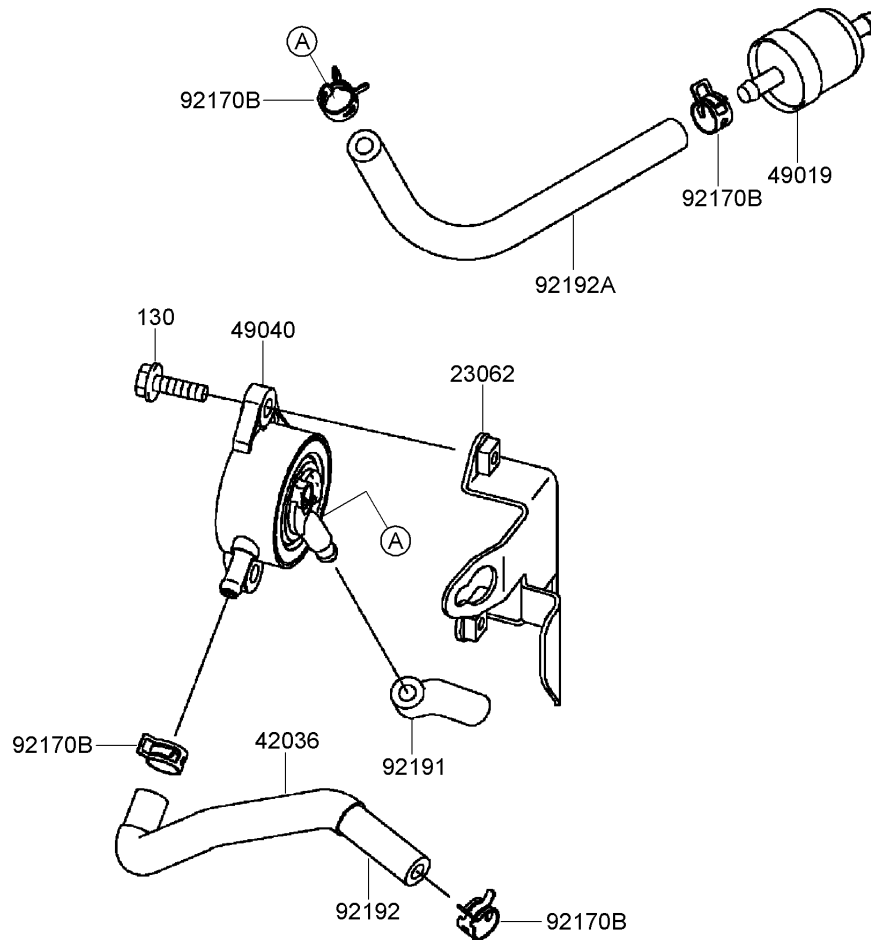

Fuel Tank and Valve Assembly Kawasaki FH430V-CS25

Ref	Part No.	Qty.	Description
① 23062	23062-7004-9H	1	Bracket
① 42036	42036-7012	1	Sleeve
① 49019	49019-7001	1	Filter-Fuel
① 49040	49040-7001	1	Pump-Fuel
④ 92170B	92170-2088	4	Clamp
① 92191	92191-7002	1	Tube
① 92192	92192-7035	1	Tube (6.35X12.7X170)
① 92192A	92192-7037	1	Tube (6.35X12.7X160)
② 130	130B0620	2	Bolt-Flanged (6X20)

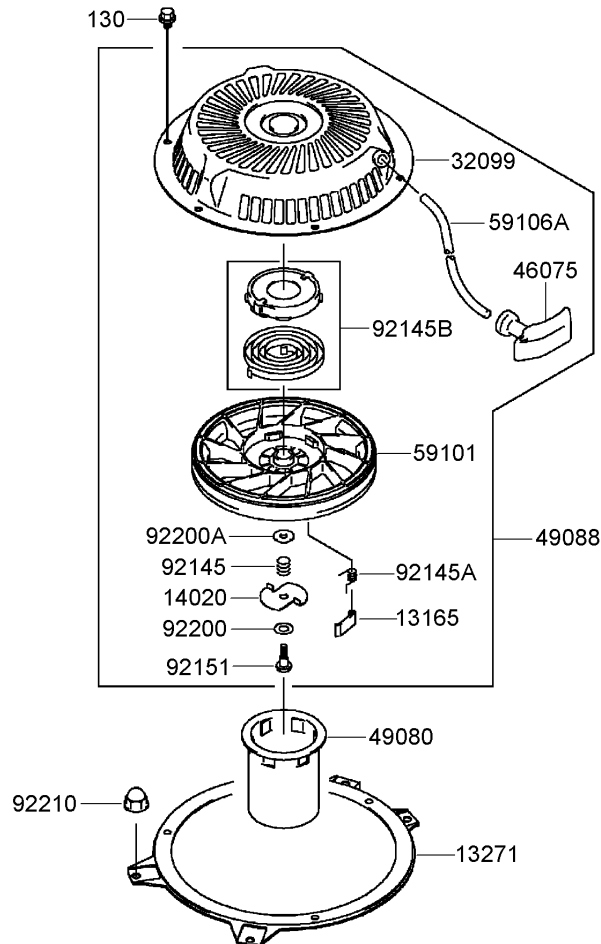

Starter Assembly Kawasaki FH430V-CS25

Ref	Part No.	Qty.	Description				
③ 13165	13165-7001	2	Pawl-Starter, Recoil				
③ 13271	13271-7003-9H	1	Plate				
③ 14020	14020-7001	1	Retainer				
③ 32099	32099-7002	1	Case-Starter, Recoil				
③ 46075	46075-7001	1	Grip-Starter, Recoil				
③ 49080	49080-7001	1	Pulley-Starting				
③ 49088	49088-7013	1	Starter-Recoil				
③ 59101	59101-7001	1	Reel-Starter, Recoil				
③ 59106A	59106-7005	1	Rope				
③ 92145	92145-7006	1	Spring				
③ 92145A	92145-7007	2	Spring				
③ 92145B	92145-7008	1	Spring				
③ 92151	92151-7008	1	Bolt				
③ 92200	92200-7004	1	Washer				
③ 92200A	92200-7005	1	Washer				
③ 92210	92210-0003	4	Nut				
③ 130	130B0608	3	Bolt-Flanged (6X8)				

56033



56070



56080



56080A



Label Assembly Kawasaki FH430V-CS25

Ref	Part No.	Qty.	Description				
⑤56033	56033-7001	1	Label-Manual				
⑤56070	56070-7001	1	Label-Warning				
⑤56080	56080-2077	1	Label-Brand				
⑤56080A	56080-7024	1	Label-Brand				

Attachments and Accessories

For 30984 - Commercial Walk-Behind Mower, Fixed Deck Pistol Grip Hydro with 36in
TURBO FORCE Cutting Unit

Product Name	Model/Part
Blade-Recycler, 18 Inch	105-7779-03
Blade-Med Flow, 18 Inch	105-7794-03
Blade-Low Flow, 18 Inch	105-7795-03
Blade-Atomic, 18 Inch	105-7796-03
36 Inch Bagger Enhancement Kit	110-2026
36 Inch Recycler Kit	110-2080
Weight Kit	110-2085
Soft Bag (3 Bushel)	30104
Sulky	30109

NOTES

NOTES

NOTES

