



Groundsmaster[®] 3320

Model No. 30343 - 270000001 and up.

Parts Catalog

Ordering Replacement Parts

To order replacement parts, please supply the part number, the quantity, and the description of each part desired.

Understanding Reference Numbers

Each Identified part in an illustration has a reference number. The reference number for a part also appears in the parts list, along with other information about the part.

This catalog uses two special reference number formats, one to indicate parts in a service assembly and another to indicate the quantity of a given part in an illustration.

Service Assembly Reference Numbers

Parts in service assemblies have reference numbers in the form a:b. The a represents the reference number of the entire service assembly and the b represents a sequential number unique to each part within the service assembly.

For example, a wheel assembly might be identified by reference number 6, the tire by 6:1, the valve by 6:2, and the wheel by 6:3. When you order the assembly identified by reference number 6, you receive all parts identified by reference numbers 6:1, 6:2, and 6:3. However, you may also order any part individually. Reference numbers of this type appear in illustrations and in part lists.

Reference Numbers Indicating Quantity

In an illustration, if a reference number indicates more than one part, the reference number has the form nX y. The n represents the quantity of the part, the X is the multiplication symbol, and the y represents the reference number.

For example, in an illustration, the reference number 2X 37 means that two of the parts identified by reference number 37 are indicated.

Contents

Description	Page	Description	Page
Frame and Hood Assembly 3	Air Cleaner and Drive Coupling Assembly 22
Frame Assembly No. 108-2010 4	Engine, Muffler and Clutch Assembly 23
Fuel Tank and Control Panel Assembly 5	Air Cleaner Assembly No. 104-3428 24
Power Steering Assembly 6	Front Axle Assembly 25
Traction Pedal Assembly 7	Front Axle Assembly No. 108-6599-03 26
Brake Pedal Assembly 8	Right and Left Hand Brake Assembly 28
Battery and Engine Mount Assembly 9	Cylinder Assembly 29
Power-Take-Off and Shaft Assembly 10	Crankshaft Assembly 30
Hydraulic Cylinder and Lift Valve Assembly 11	Cylinder Head Assembly 31
Radiator Assembly 12	Intake and Exhaust 32
Transmission Installation Assembly 13	Carburetor Assembly 33
Center Section Assembly Transmission Assembly No. 108-1355 14	Rocker Arm Assembly 34
Neutral Return Arm Assembly Transmission Assembly No. 108-1355 16	Oil Pan and Dipstick Cover Assembly 36
Fuel Delivery System Assembly 17	Gears and Housing 37
Lower Control Panel Assembly 18	Water Pump and Fan Assembly 38
Rear Axle and Tire Assembly 19	Governor Assembly 39
Rear Axle Assembly 20	Alternator and Starter Assembly 40
Steering Cylinder Assembly No. 76-2070 21	Gasket Set and Valve Overhaul Kit 41
		Carburetor Kit 42
		Attachments and Accessories List 43

Part Description Abbreviations

Part descriptions in this catalog may include the following abbreviations.

AR. as required	HYD. hydraulic
ASM. assembly	LH. left hand
BBC. blade brake clutch	NI. nylon insert
CARR. carriage	NPTF. national pipe thread fine
DEG. degrees	PFH. phillips flat head
EXT. external	PPH. phillips pan head
FH. flat head	PPHTF. phillips pan head thread forming
GA. gauge	PRH. phillips round head
HD. heavy-duty	PTH. phillips truss head
HF. hex flange	PTO. power-take-off
HH. hex head	RH. right hand
HHF. hex head flange	ROPS. roll-over protection system
HHFTF. hex head flange thread forming	SFH. slotted fillister head
HJ. hex jam	SHH. slotted hex head
HLH. hex lag head	SHWH. slotted hex washer head
HOC. height-of-cut	SPH. slotted pan head
HSBH. hex socket button head	SQH. square head
HSFH. hex socket flat head	SRH. slotted round head
HSH. hex socket head	STD. standard
HWH. hex washer head	TAP. self tapping
HWHTF. hex washer head thread forming	TTH. torx truss head

Footnotes

❶ Not illustrated

❷ Not serviced separately

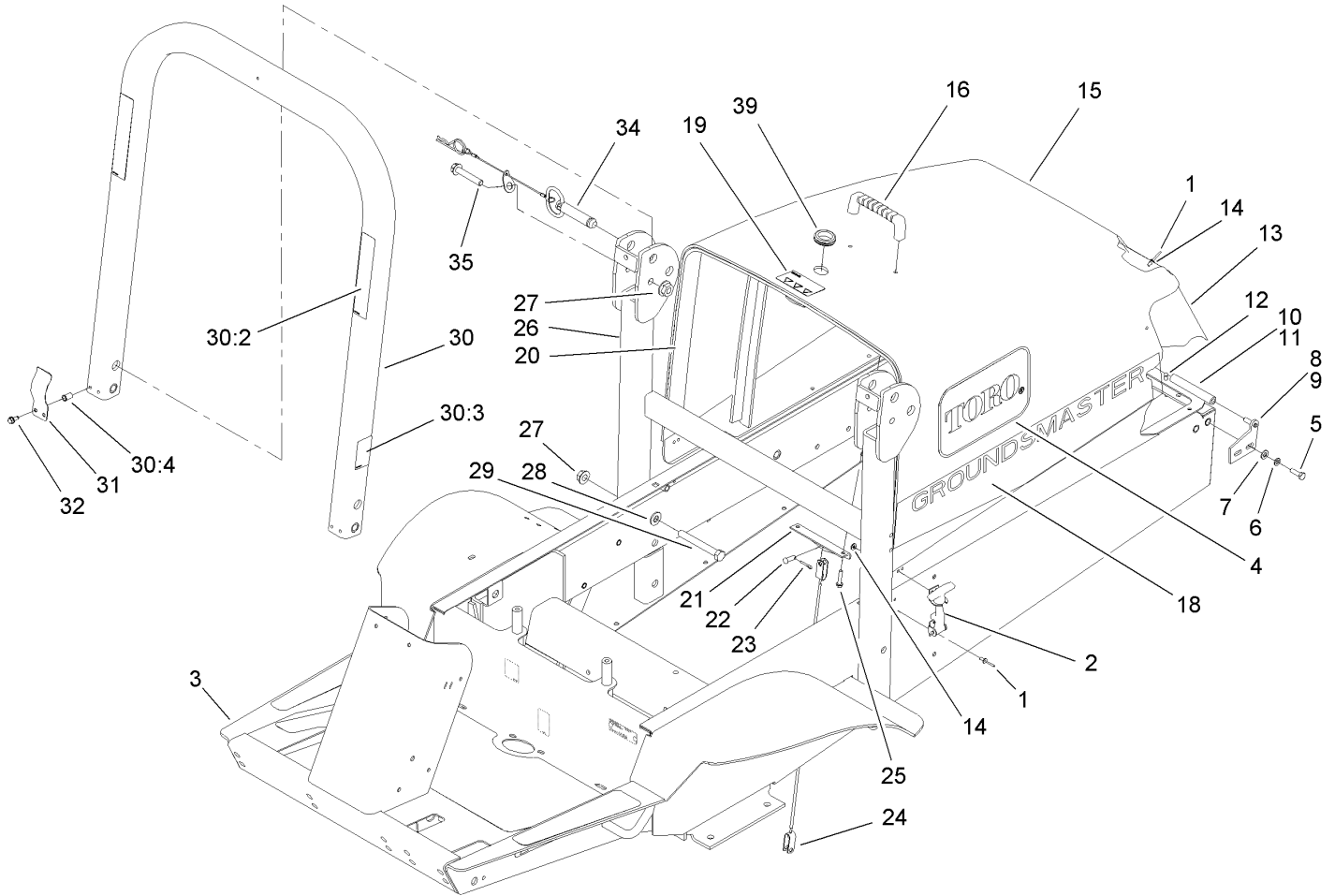

Frame and Hood Assembly

Ref	Part No.	Qty.	Description
1	3269-4	18	Rivet-Pop
2	95-6339	2	Latch
3	108-2010	1	Frame ASM
4	66-6140	2	Decal
5	322-5	4	Screw-HH
6	3253-4	4	Washer-Lock
7	3256-23	4	Washer-Flat
8	105-0003-01	1	RH Hinge Pin ASM
9	105-0004-01	1	LH Hinge Pin ASM
10	105-4278-03	1	LH Hood Hinge ASM
11	105-4277-03	1	RH Hood Hinge ASM
12	3290-412	12	Rivet
13	105-0006-03	1	Screen-Hood
14	3256-14	14	Washer-Flat
15	104-3485	1	Hood
16	65-5100	1	Handle-Door
18	108-2069	2	Decal
19	106-6754	1	Decal-Danger
20	105-3651	1	Strip-Foam
21	105-0088-03	1	Bracket-Cable, Hood
22	283-58	2	Pin-Clevis
23	3272-10	2	Pin-Cotter
24	105-3650	1	Cable-Hood
25	46-8092	2	Screw-Plastite

Ref	Part No.	Qty.	Description
26	110-5693-03	1	Lower ROPS ASM
27	32128-23	6	Nut-HF
28	3256-26	4	Washer-Flat
29	325-18	4	Screw-HH
30	110-5690	1	Upper ROPS ASM
30:2	108-2073	2	Decal-Warning
30:3	108-2074	1	Decal-ROPS
30:4	32148-11	4	Insert-Threaded
31	110-5696	2	Spring-Leaf
32	32144-10	4	Screw-HWH
34	103-4553	2	ROPS Fold Pin ASM
35	325-13	2	Screw-HH
39	104-1453	1	Grommet

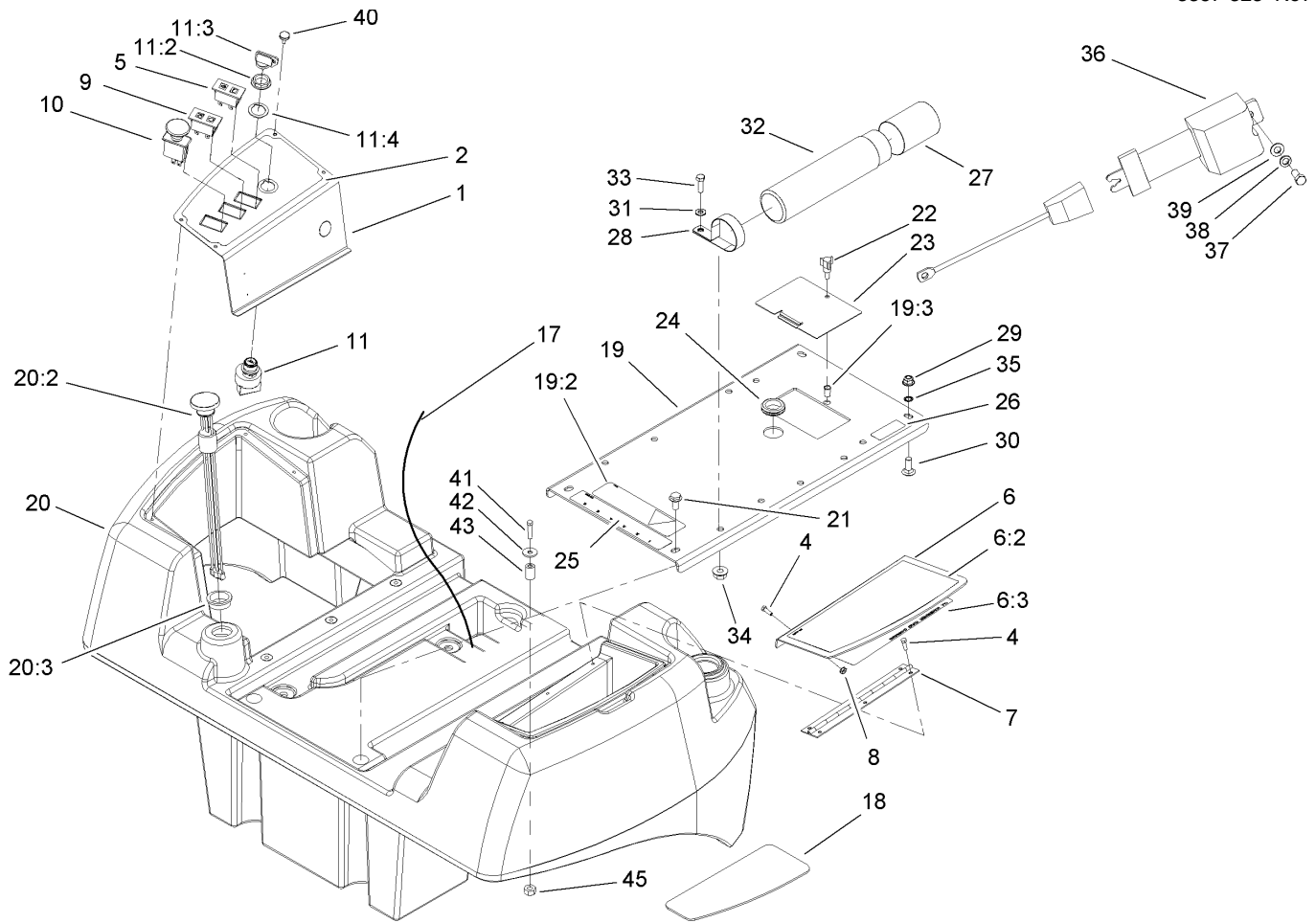

Fuel Tank and Control Panel Assembly

Ref	Part No.	Qty.	Description
1	108-2017-03	1	Plate-Panel, Control
2	108-2018	1	Decal-Panel, Control
4	112-6349	6	Screw-HWH
5	100-8070	1	Lamp-Warning
6	108-6582	1	Cover ASM
6:2	108-6585	1	Decal-Danger
6:3	108-6584	1	Decal-Service
7	108-2024	1	Hinge
8	32149-8	3	Nut-Keps
9	100-8071	1	Lamp-Warning
10	93-9999	1	Switch-PTO
11	106-5269	1	Ignition Switch ASM
11:2	108-8660	1	Nut-Mounting
11:3	106-5270	1	Key Set-Ignition
11:4	108-8659	1	Washer-Backup
17	108-8657	1	Harness-Wire, Seat
18	108-2013	1	Pad-Rubber
19	108-6580	1	Seat Plate ASM
19:2	93-7841	1	Decal-Warning
19:3	32148-6	1	Insert-Nut
20	108-6596	1	Fuel Tank ASM
20:2	108-2025	1	Gauge-Fuel
20:3	95-8972	1	Grommet
21	3234-1	2	Screw-HHF

Ref	Part No.	Qty.	Description
22	233-70	1	Knob-Star, Three
23	108-2027-03	1	Cover-Bypass
24	240-5	1	Grommet
25	105-9584	1	Decal-Instructions, Starting
26	71-3730	1	Decal-Gas
27	104-7048	1	Cap-Housing
28	2412-133	2	R-Clamp
29	104-8301	2	Nut-Flange, NI
30	3231-2	2	Screw-CARR
31	3256-23	2	Washer-Flat
32	104-7050	1	Housing-Manual
33	322-5	2	Screw-HH
34	32128-20	2	Nut-HF
35	32151-72	2	Ring-Retaining
36	100-4928	1	Belt-Seat
37	3212-4	2	Screw-HH
38	3253-6	2	Washer-Lock
39	3256-25	2	Washer-Flat
40	108-8689	4	Screw-Thumb
41	321-9	1	Screw-HH
42	3256-55	1	Washer-Flat
43	108-9688	1	Spacer
45	3296-42	1	Nut-Lock, NI

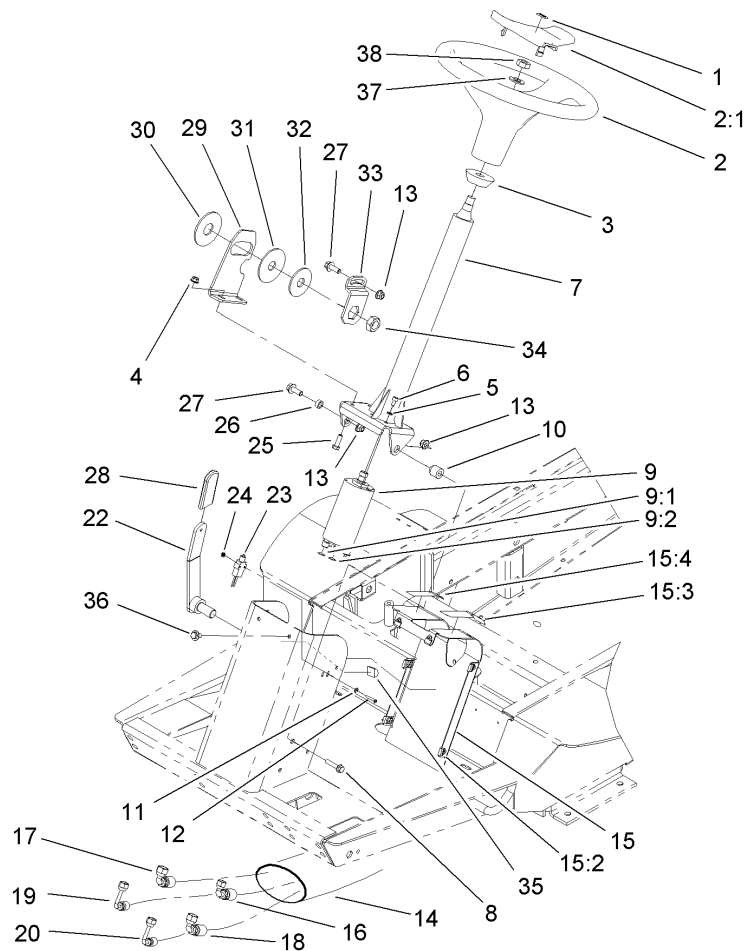

Power Steering Assembly

Ref	Part No.	Qty.	Description
1	98-1459	1	Decal
2	98-1471	1	Wheel-Steering
2:1	98-1468	1	Cover-Wheel, Steering
3	93-5429	1	Collar-Foam
4	104-8300	2	Nut-Flange, NI
5	43-5930	4	Washer-Spring
6	99-7202	4	Screw
7	106-8098	1	Steering Column ASM
8	3234-18	1	Screw-HHF
9	108-2077	1	Steering Valve ASM
9:1	237-21	3	O-Ring
9:2	237-22	2	O-Ring
10	105-7166	1	Spacer
11	3256-53	2	Washer-Flat
12	3250-35	2	Screw-PPH
13	104-8301	3	Nut-Flange, NI
14	44-8530	1	Protector-Sleeve
15	105-7180	1	Tower Panel ASM
15:2	105-7170	6	Nut-Retainer
15:3	105-7179	1	Decal-Brake, Parking
15:4	82-8940	1	Decal-Steering, Tilt
16	108-2089	1	Hose ASM
17	108-2081	1	Hose ASM
18	108-2080	1	Hose ASM

Ref	Part No.	Qty.	Description
19	108-2086	1	Hose ASM
20	108-2087	1	Hose ASM
22	93-1353-03	1	Lever-Steering, Tilt
23	99-3410	1	Switch
24	32149-6	2	Nut-Keps
25	322-5	2	Screw-HH
26	80-2960	1	Spacer-Tower
27	3234-42	2	Screw-HHF
28	21-1880	1	Grip-Handle
29	105-7181-03	1	Plate-Pivot
30	31-0390	1	Disc-Friction
31	82-9010	1	Disc-Friction
32	80-2930	1	Washer-Flat
33	80-2880	1	Bracket-Tilt
34	3218-7	1	Nut-Jam
35	105-7188	2	Clamp-Adhesive
36	3250-32	6	Screw-PPH
37	3256-27	1	Washer-Flat
38	3296-33	1	Nut-Lock, NI

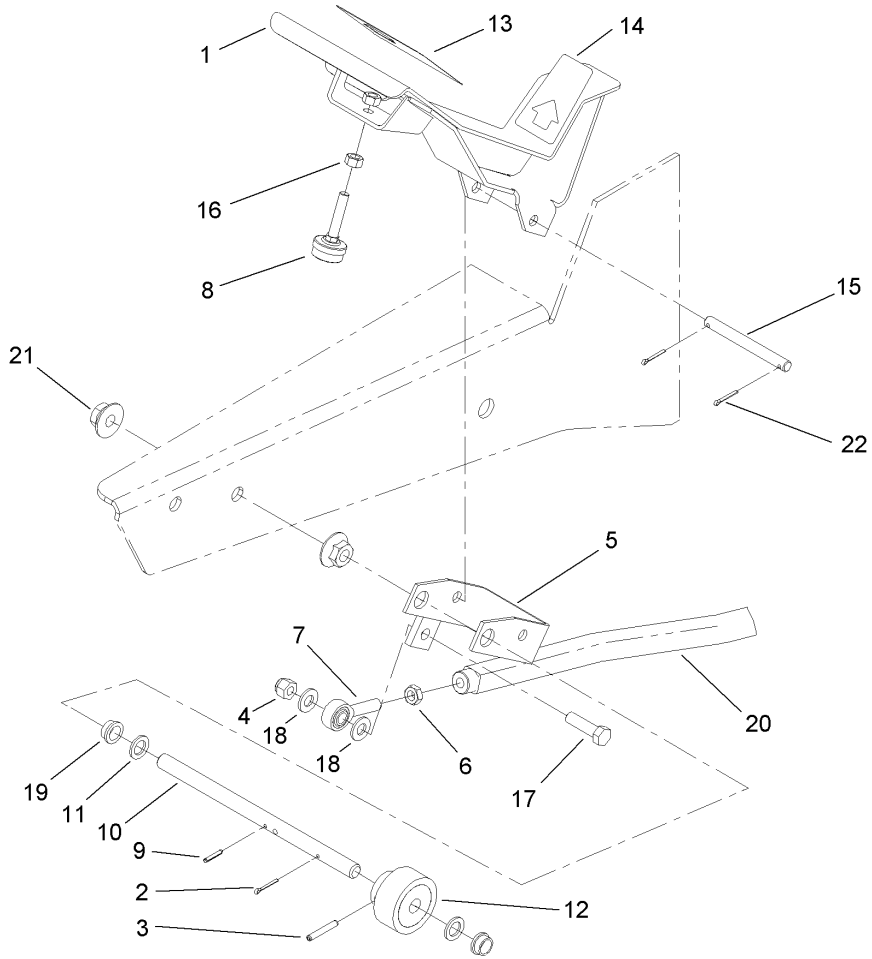

Traction Pedal Assembly

Ref	Part No.	Qty.	Description
1	105-7150-03	1	Pedal ASM
2	3272-6	1	Pin-Cotter
3	32121-6	1	Pin-Roll, Slotted
4	3296-39	1	Nut-Lock, NI
5	92-8854-03	1	Bracket-Pivot
6	3220-3	1	Nut-HJ
7	2411-36	1	Bearing-End, Rod
8	32141-36	1	Screw-Adjustment, Level
9	32121-50	1	Pin-Spring
10	92-5534	1	Shaft-Pedal, Traction
11	5-7570	2	Washer-Flat
12	28-5220	1	Friction Wheel ASM
13	94-3307	1	Pad-Pedal, Traction
14	94-3308	1	Pad-Pedal, Traction
15	92-5537	1	Pin-Pedal, Traction
16	3217-6	2	Nut-Hex
17	323-29	1	Screw-HH
18	3256-24	2	Washer-Flat
19	256-156	2	Bushing-Flange
20	108-8661-03	1	Traction Rod ASM
21	32128-56	2	Nut-HF
22	3272-10	2	Pin-Cotter

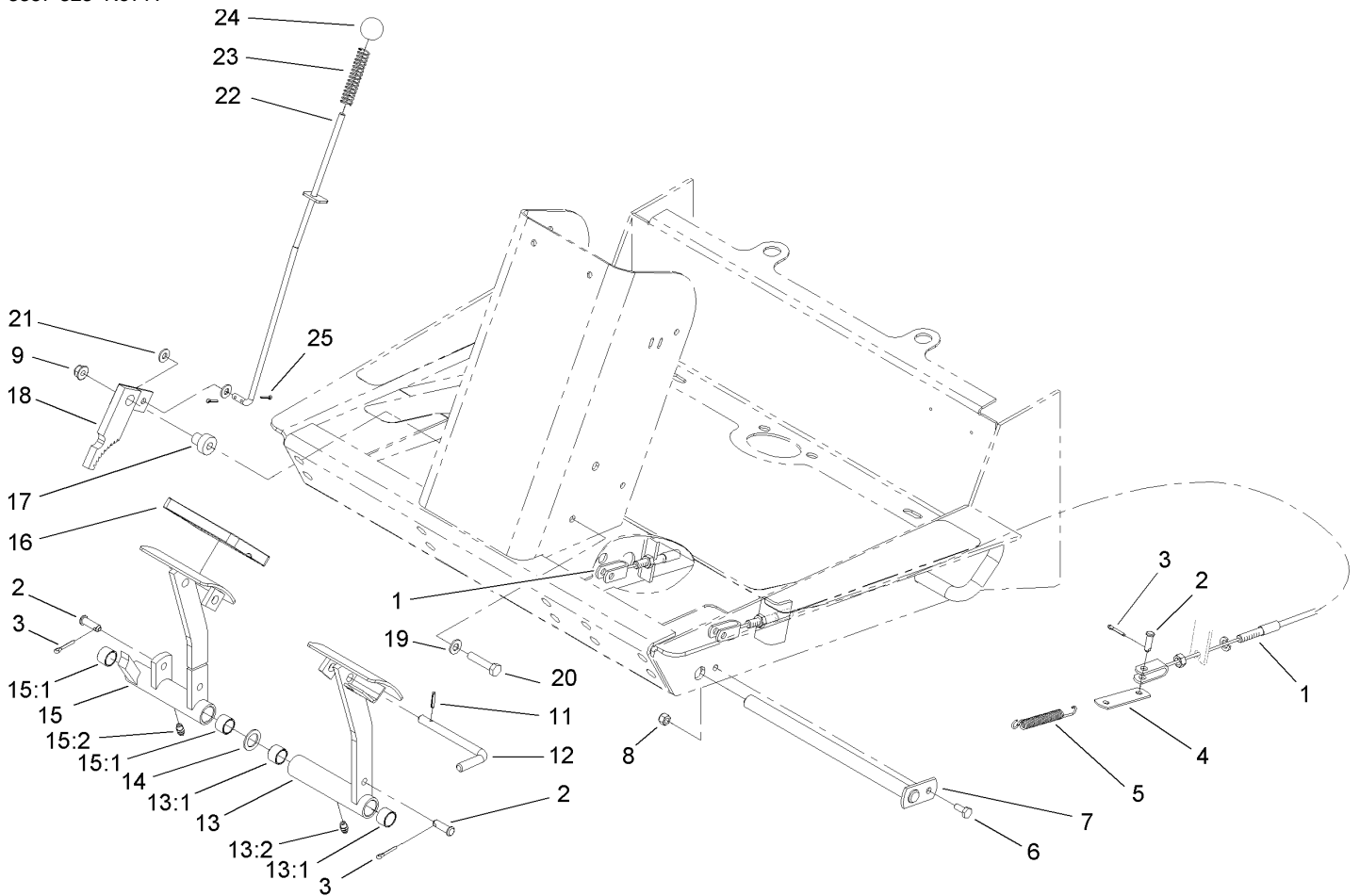

Brake Pedal Assembly

Ref	Part No.	Qty.	Description
1	108-6556	2	Cable-Brake
2	283-58	4	Pin-Clevis
3	3272-10	4	Pin-Cotter
4	63-6750	2	Link-Cable, Brake
5	3-7243	2	Spring-Extension
6	321-4	1	Screw-HH
7	63-6210-03	1	Pin-Brake
8	3296-42	1	Nut-Lock, NI
9	104-8300	1	Nut-Flange, NI
11	32121-50	1	Pin-Spring
12	63-7880	1	Pin-Latch, Brake
13	63-6180	1	Pedal-Brake, LH
13:1	256-42	2	Bushing
13:2	302-5	1	Fitting-Grease
14	3256-69	2	Washer-Flat
15	63-6190	1	Pedal-Brake, RH
15:1	256-42	2	Bushing
15:2	302-5	1	Fitting-Grease
16	93-8742	2	Footpad-Brake
17	105-7156	1	Spacer
18	63-7900-03	1	Rack ASM
19	3256-23	1	Washer-Flat
20	322-7	1	Screw-HH
21	3256-22	2	Washer-Flat

Ref	Part No.	Qty.	Description
22	105-7168	1	Rod ASM
23	71-8310	1	Spring-Compression
24	233-17	1	Knob
25	3272-5	2	Pin-Cotter

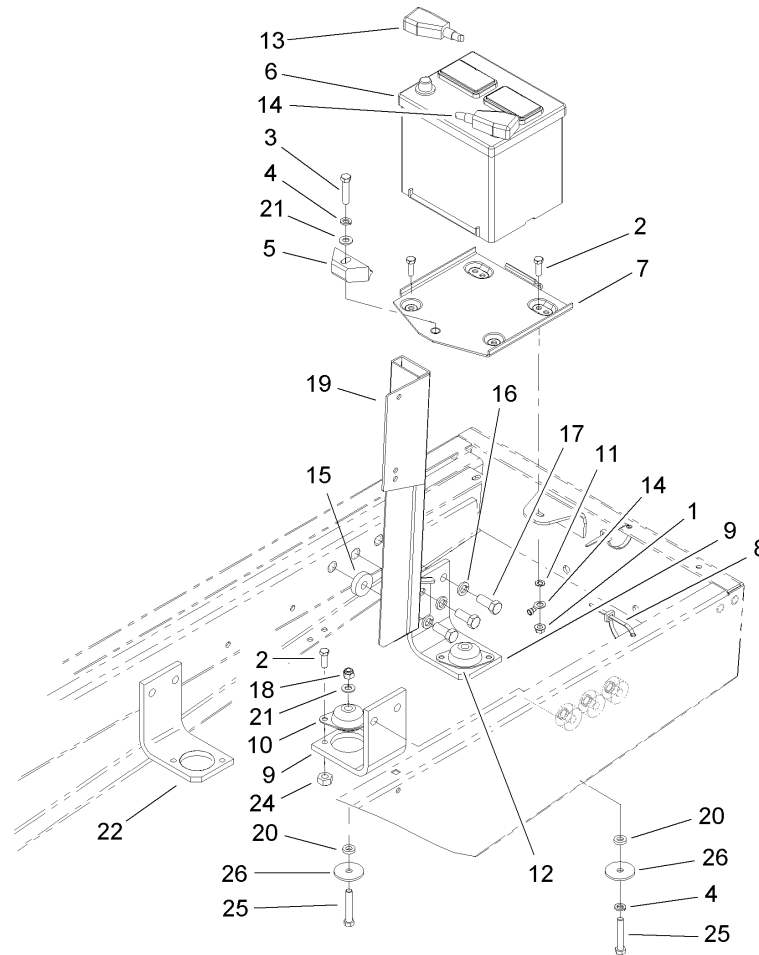

Battery and Engine Mount Assembly

Ref	Part No.	Qty.	Description	Ref	Part No.	Qty.	Description
1	32128-20	3	Nut-HF	26	63-7400	4	Washer-Rebound
2	322-5	11	Screw-HH				
3	323-9	1	Screw-HH				
4	3253-21	2	Washer-Lock				
5	66-2490	1	Retainer-Battery				
6	106-5187	1	Battery				
7	94-7343	1	Battery Base ASM				
8	3290-378	2	Tie-Cable				
9	95-6272-03	2	Bracket-Engine Mount				
10	63-7141	1	Mount-Shock, Engine				
11	3255-8	1	Washer-Lock				
12	63-7140	3	Mount-Shock, Engine				
13	104-0086	1	Cable-Battery, Positive				
14	87-3080	1	Cable-Battery, Negative				
15	99-1291	1	Spacer				
16	3253-7	9	Washer-Lock				
17	3213-2	9	Screw-HH				
18	3296-39	3	Nut-Lock, NI				
19	105-2513-03	1	Air Cleaner Mount ASM				
20	80-7730	4	Spacer				
21	3256-24	4	Washer-Flat				
22	95-6271-03	2	Bracket-Mount, Engine				
24	3296-29	8	Nut-Lock, NI				
25	323-11	4	Screw-HH				

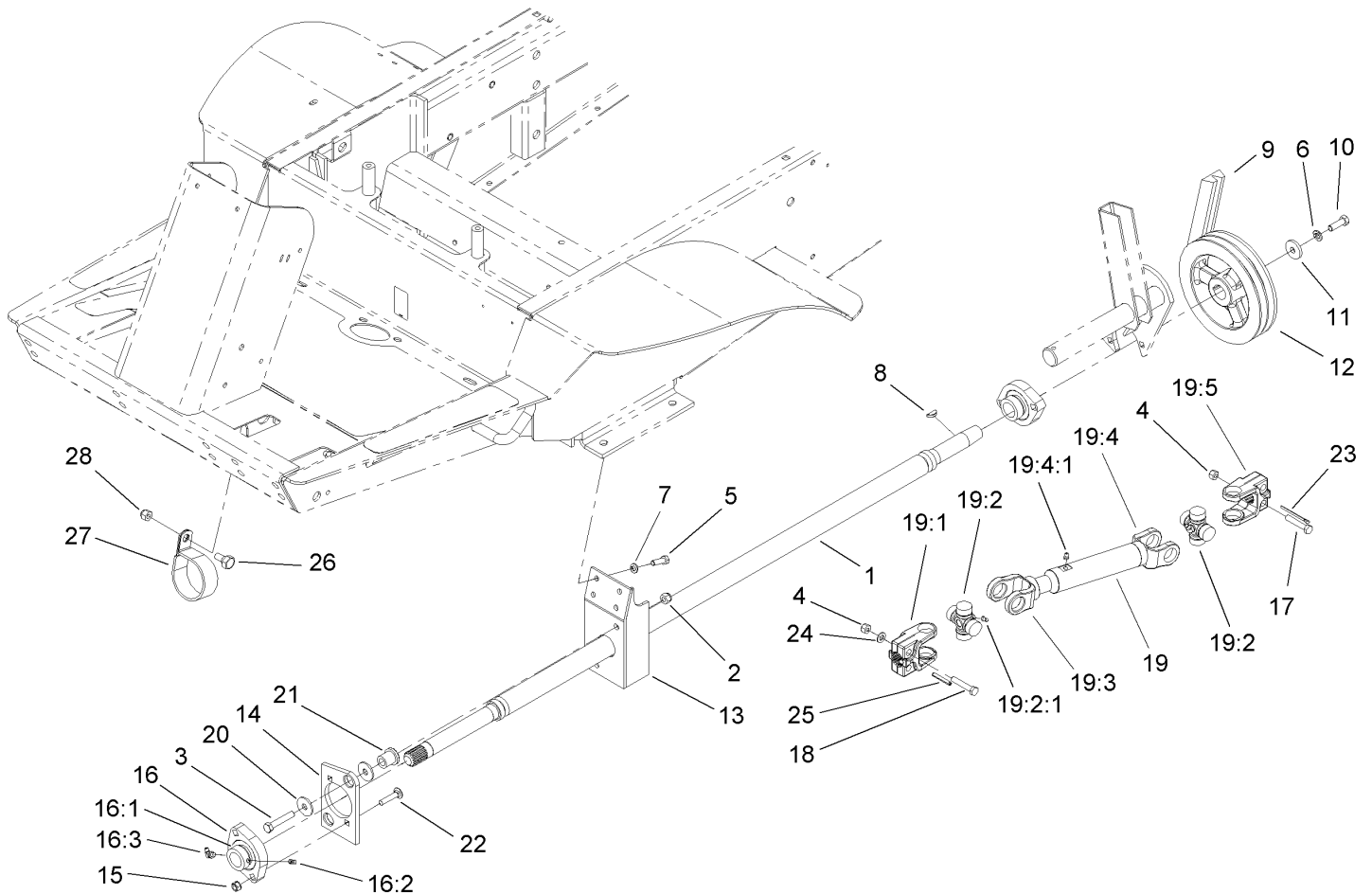

Power-Take-Off and Shaft Assembly

Ref	Part No.	Qty.	Description
1	92-8855-03	1	Shaft-PTO
2	3296-39	2	Nut-Lock, NI
3	323-10	2	Screw-HH
4	3296-29	5	Nut-Lock, NI
5	322-5	4	Screw-HH
6	3253-21	1	Washer-Lock
7	3253-4	4	Washer-Lock
8	3257-5	1	Key-Woodruff
9	63-6240	1	V-Belt
10	323-18	1	Screw-HH
11	29-4730	1	Washer-Flat
12	94-7422-03	1	Pulley-PTO
13	92-8751-03	1	PTO Bearing Bracket ASM
14	84-7580	1	Plate-Support, Bushing
15	32149-1	2	Nut-Keps
16	92-8799	1	Bearing-Flange
16:1	251-77	1	Collar-Lock, Bearing
16:2	3245-35	1	Screw-Set
16:3	302-40	1	Fitting-Grease
17	322-9	4	Screw-HH
18	322-14	1	Screw-HH
19	108-1366	1	PTO Drive Shaft ASM
19:1	54-9040	1	Yoke-End
19:2	54-9180	2	U-Joint Kit

Ref	Part No.	Qty.	Description
19:2:1	62-3820	1	Fitting-Grease
19:3	108-6550	1	Shaft-Yoke, Slip
19:4	108-6551	1	Tube-Yoke, Slip
19:4:1	302-58	1	Fitting-Straight
19:5	54-9090	1	Yoke-End
20	63-8410	4	Washer
21	63-9750	2	Mount
22	3230-4	2	Screw-CARR
23	3272-15	1	Pin-Cotter
24	3256-23	1	Washer-Flat
25	32121-34	1	Pin-Roll
26	46-3380	1	Bolt-Shoulder
27	2412-102	1	Clamp-R
28	3296-39	1	Nut-Lock, NI

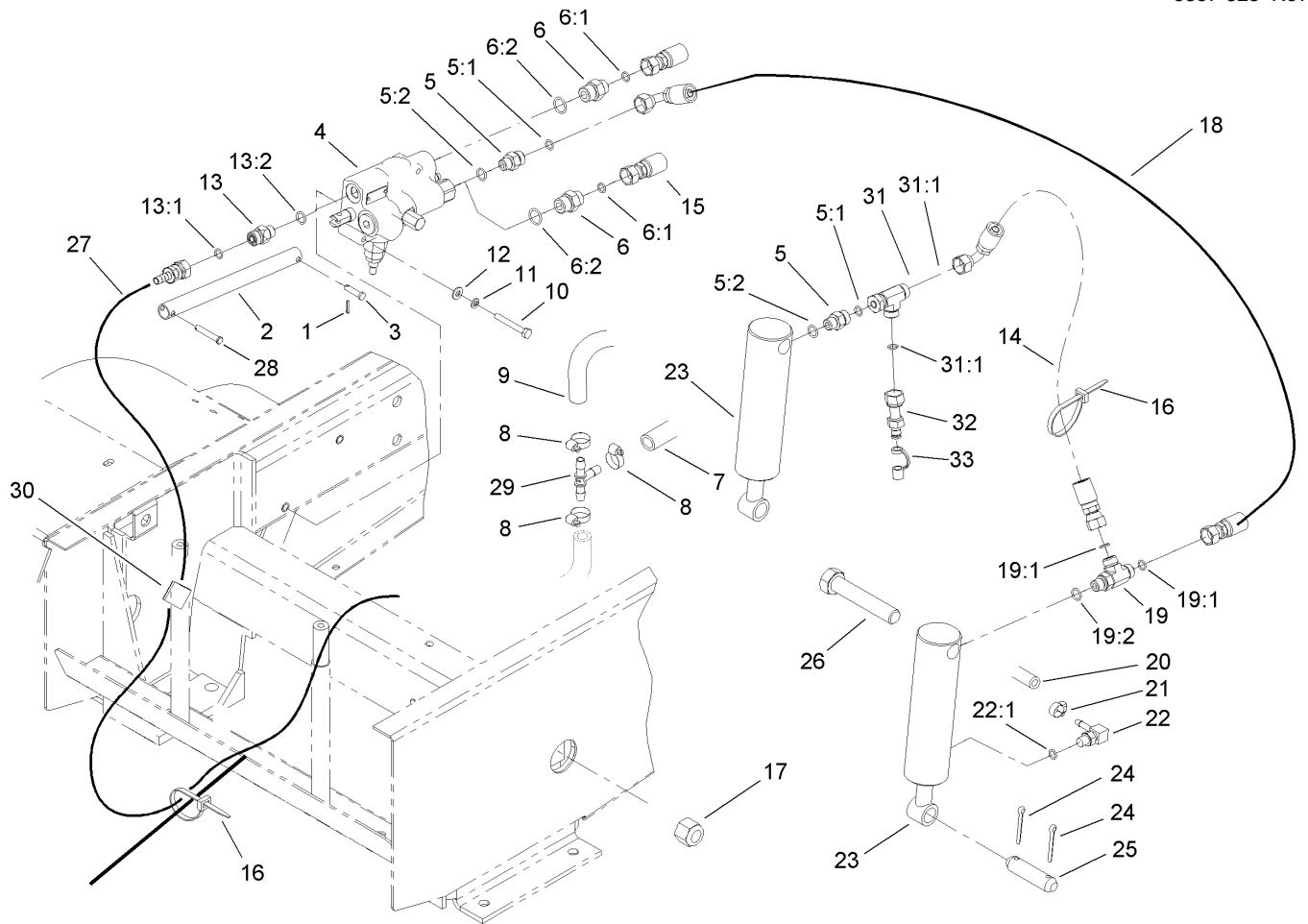

Hydraulic Cylinder and Lift Valve Assembly

Ref	Part No.	Qty.	Description
1	3272-5	2	Pin-Cotter
2	108-2021-03	1	Tube-Link
3	283-26	1	Pin
4	108-2022	1	Control Valve ASM
④4:1	108-8690	1	Cartridge-Transfer, Weight
④4:2	108-8691	1	Pilot Check Kit
④4:3	108-8692	1	Spring Center Kit
④4:4	108-8693	1	Seal Kit
5	340-2	2	Fitting-HYD, Straight
5:1	237-22	1	O-Ring
5:2	237-42	1	O-Ring
6	340-3	2	Adapter
6:1	237-22	1	O-Ring
6:2	237-79	1	O-Ring
7	66-8500	1	HYD Hose ASM
8	2412-36	3	Clamp-Hose
9	100-5649	1	Hose
10	321-18	2	Screw-HH
11	3253-3	2	Washer-Lock
12	3256-22	2	Washer-Flat
13	108-2093	1	Valve-Check
13:1	237-22	1	O-Ring
13:2	237-42	1	O-Ring
14	108-2083	1	Hose ASM

Ref	Part No.	Qty.	Description
15	108-2097	1	Hose ASM
16	3290-378	2	Tie-Cable
17	3296-51	2	Nut-Lock, NI
18	108-2082	1	Hose ASM
19	340-86	1	Fitting-HYD, Tee
19:1	237-22	2	O-Ring
19:2	237-42	1	O-Ring
20	92-5082	2	Hose-HYD
21	2412-108	2	Clamp-Worm
22	304-99	2	Stem-Hose
22:1	237-78	1	O-Ring
23	63-6630	2	Cylinder-HYD
24	3272-23	4	Pin-Cotter
25	27-4240	2	Pin-Cylinder
26	328-7	2	Screw-HH
27	108-2090	1	Hose ASM
28	283-66	1	Pin-Clevis
29	354-107	1	Fitting-HYD, Tee
30	105-7188	1	Clamp-Adhesive
31	340-115	1	Fitting-Tee
31:1	237-22	2	O-Ring
32	86-5480	1	Nipple-Test
33	354-79	1	Cap-Dust

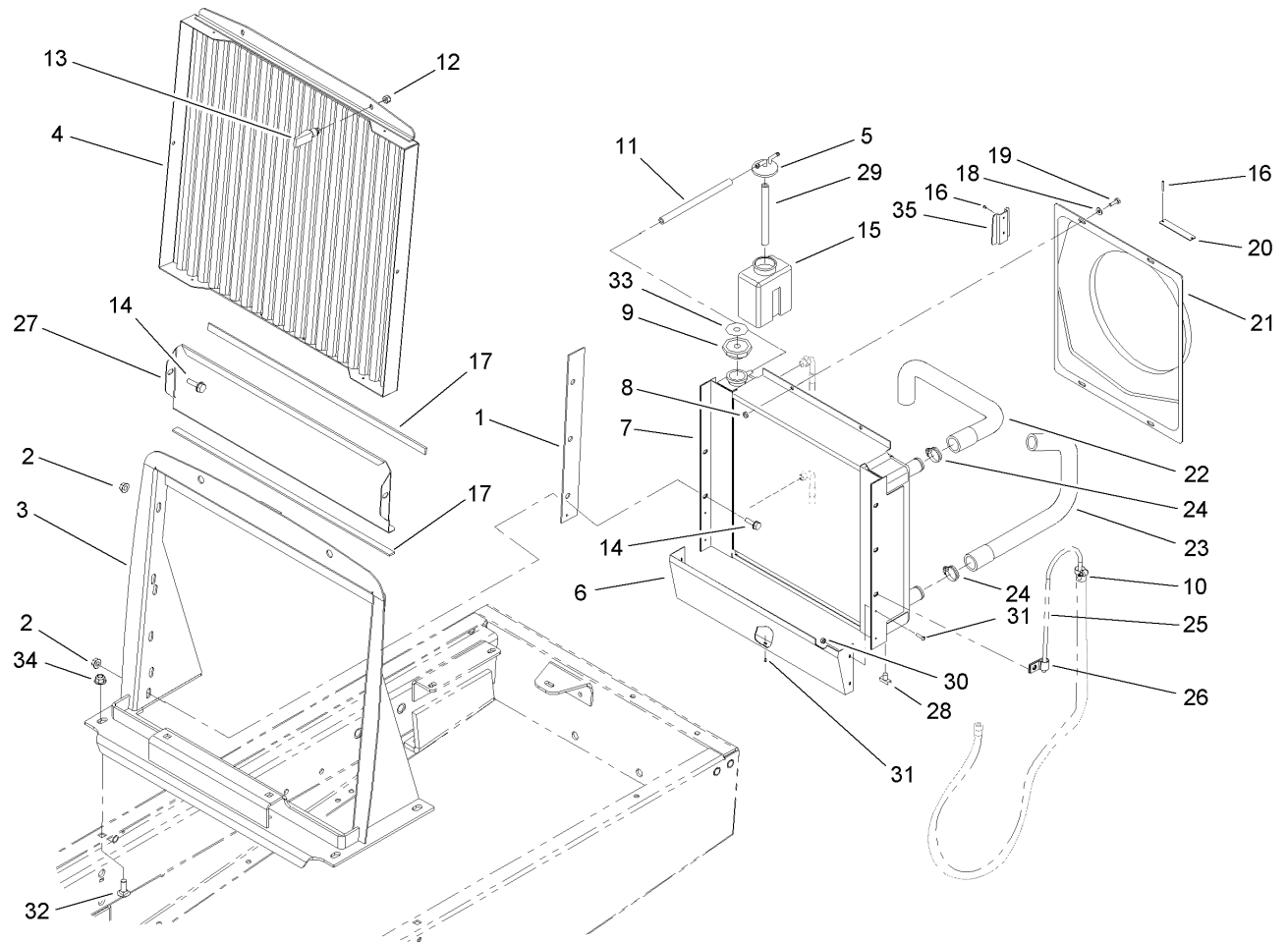

Radiator Assembly

Ref	Part No.	Qty.	Description
1	108-2096-03	1	Shim-Radiator
2	32128-20	8	Nut-HF
3	110-9668-03	1	Radiator Support ASM
4	108-2062-03	1	Screen ASM
5	99-9171	1	Cap-Surge, Tank
6	110-9664-03	1	Shield-Radiator, Bottom
7	63-6150	1	Radiator ASM
8	3296-42	4	Nut-Lock, NI
9	66-3240	1	Cap-Radiator
10	2412-108	1	Clamp-Worm
11	110-4104	1	Hose-Fuel
12	1-804254	2	Nut
13	74-5950	2	Latch-Swell
14	3234-5	8	Screw-HHF
15	99-9154	1	Tank-Reserve
16	3290-55	4	Rivet-Pop
17	108-1393	2	Strip-Foam
18	3256-22	4	Washer-Flat
19	321-4	4	Screw-HH
20	76-8750	1	Plate-Warning
21	94-6750	1	Shroud-Fan
22	94-6756	1	Hose-Radiator
23	94-7421	1	Hose-Radiator, Lower
24	2412-34	4	Clamp-Hose

Ref	Part No.	Qty.	Description
25	66-3180	1	Tube-Vent
26	2412-103	2	Clamp
27	108-2037-03	1	Cover-Intake
28	304-46	1	Draincock
29	109-0310	1	Hose-Fuel
30	3269-10	2	Washer-Back
31	3269-13	5	Rivet-Pop
32	3231-2	4	Screw-CARR
33	106-5976	1	Decal-Warning
34	104-8301	4	Nut-Flange, NI
35	94-7337	1	Bracket-Bottle, Overflow

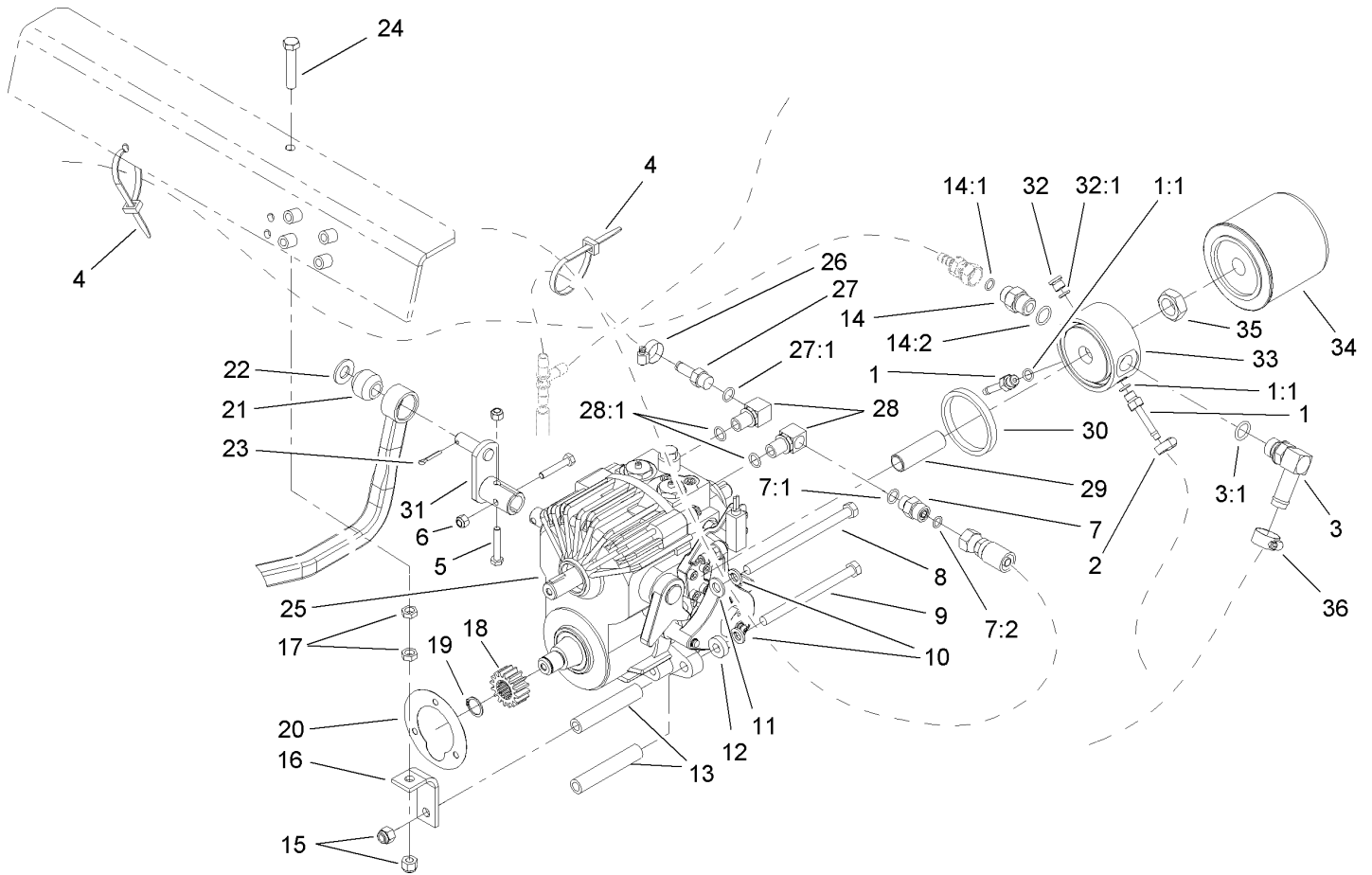

Transmission Installation Assembly

Ref	Part No.	Qty.	Description
1	92-5512	2	Fitting-Hose, Barbed
1:1	237-78	1	O-Ring
2	2412-108	2	Clamp-Worm
3	92-5086	1	Fitting-Elbow, 90 DEG
3:1	237-79	1	O-Ring
4	3290-378	2	Tie-Cable
5	321-9	2	Screw-HH
6	3296-42	2	Nut-Lock, NI
7	82-8530	1	Fitting-Straight
7:1	237-42	1	O-Ring
7:2	237-22	1	O-Ring
8	27-9620	1	Screw-HH
9	323-39	3	Screw-HH
10	3253-21	4	Washer-Lock
11	3256-24	1	Washer-Flat
12	5-0652	1	Spacer
13	27-3680	4	Spacer-Mounting
14	340-3	1	Adapter
14:1	237-22	1	O-Ring
14:2	237-79	1	O-Ring
15	3296-39	2	Nut-Lock, NI
16	63-7170	1	Anchor-Transmission
17	3218-3	2	Nut-Jam
18	86-7220	1	Gear-Pinion

Ref	Part No.	Qty.	Description
19	32120-72	1	Ring-Snap
20	27-3690	1	Gasket-Transmission
21	23-2270	1	Bushing-Rubber
22	3256-26	1	Washer-Flat
23	3272-10	1	Pin-Cotter
24	67-1900	1	Screw-HH
25	108-1355	1	Transmission ASM
26	2412-36	1	Clamp-Hose
27	353-979	1	Fitting-Straight
27:1	237-42	1	O-Ring
28	66-3110	2	Fitting-HYD, 90 DEG
28:1	237-42	1	O-Ring
29	92-5085	1	Union-Filter
30	92-5087	1	Seal-Adaptor, Filter
31	108-2036-03	1	Pump Lever ASM
32	353-990	1	Plug
32:1	237-78	1	O-Ring
33	92-5076	1	Adapter-Filter
34	23-2300	1	Filter-Oil, Transmission
35	3220-7	1	Nut-Jam
36	2412-119	1	Clamp-Worm

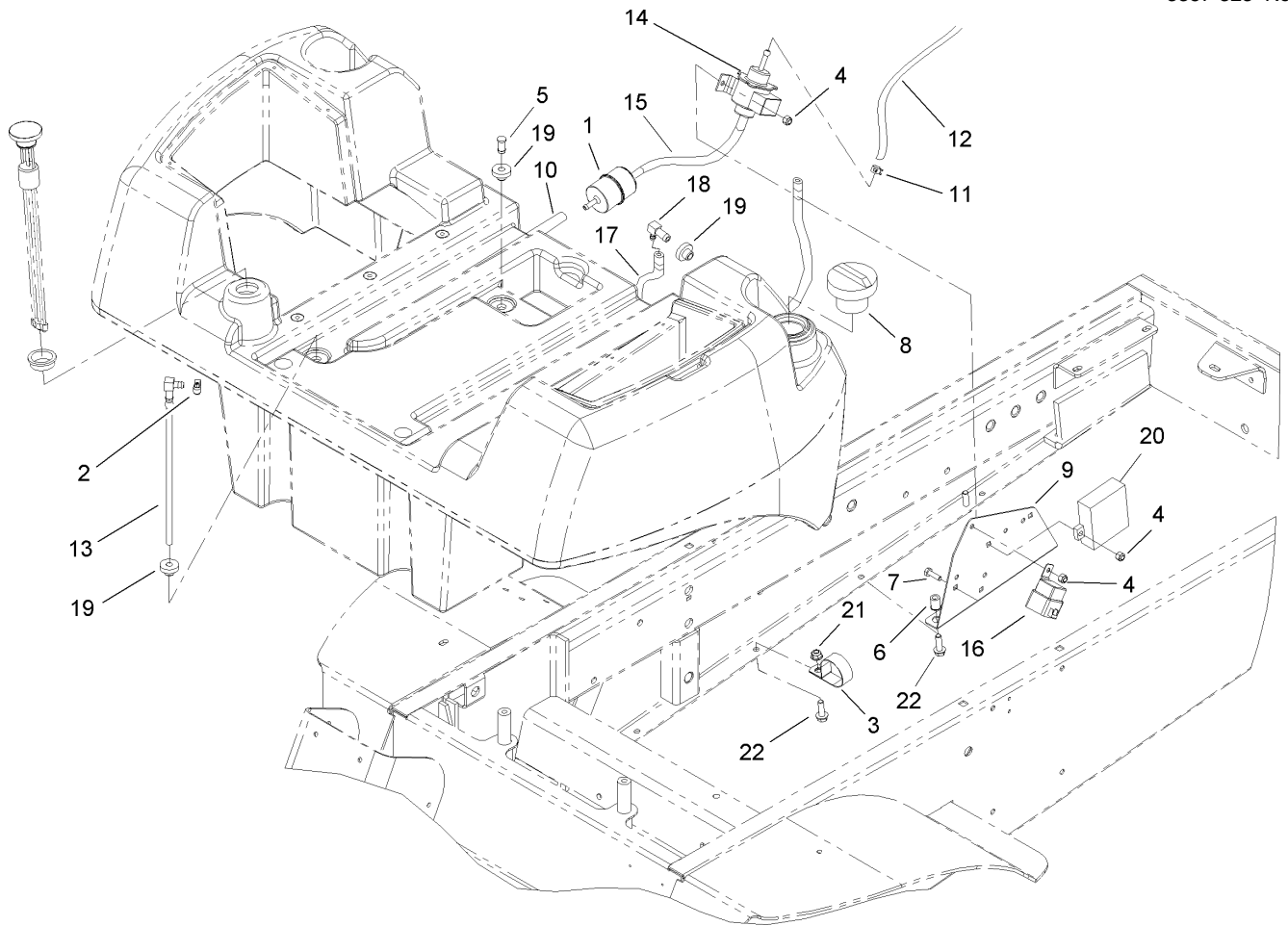

Fuel Delivery System Assembly

Ref	Part No.	Qty.	Description				
1	99-9193	1	Filter-Fuel				
2	2412-108	3	Clamp-Worm				
3	2412-147	1	Clamp				
4	3296-42	5	Nut-Lock, NI				
5	108-2066	1	Plug-Grommet				
6	32148-7	2	Nut-Insert				
7	321-5	5	Screw-HH				
8	93-7170	1	Cap-Fuel				
9	108-2078-03	1	Bracket-Support				
10	110-9662	1	Hose-Fuel				
11	2412-108	4	Clamp-Worm				
12	109-0305	1	Hose-Fuel				
13	110-9689	1	Standpipe				
14	99-9196	1	Pump-Fuel				
15	110-4105	1	Hose-Fuel				
16	99-7430	1	Relay				
17	109-0273	1	Hose-Fuel				
18	94-6765	1	Fitting-Barbed, 90 DEG				
19	46-6560	3	Bushing				
20	99-9262	1	Module-Ignition				
21	104-8300	1	Nut-Flange, NI				
22	3234-17	3	Screw-HHF				

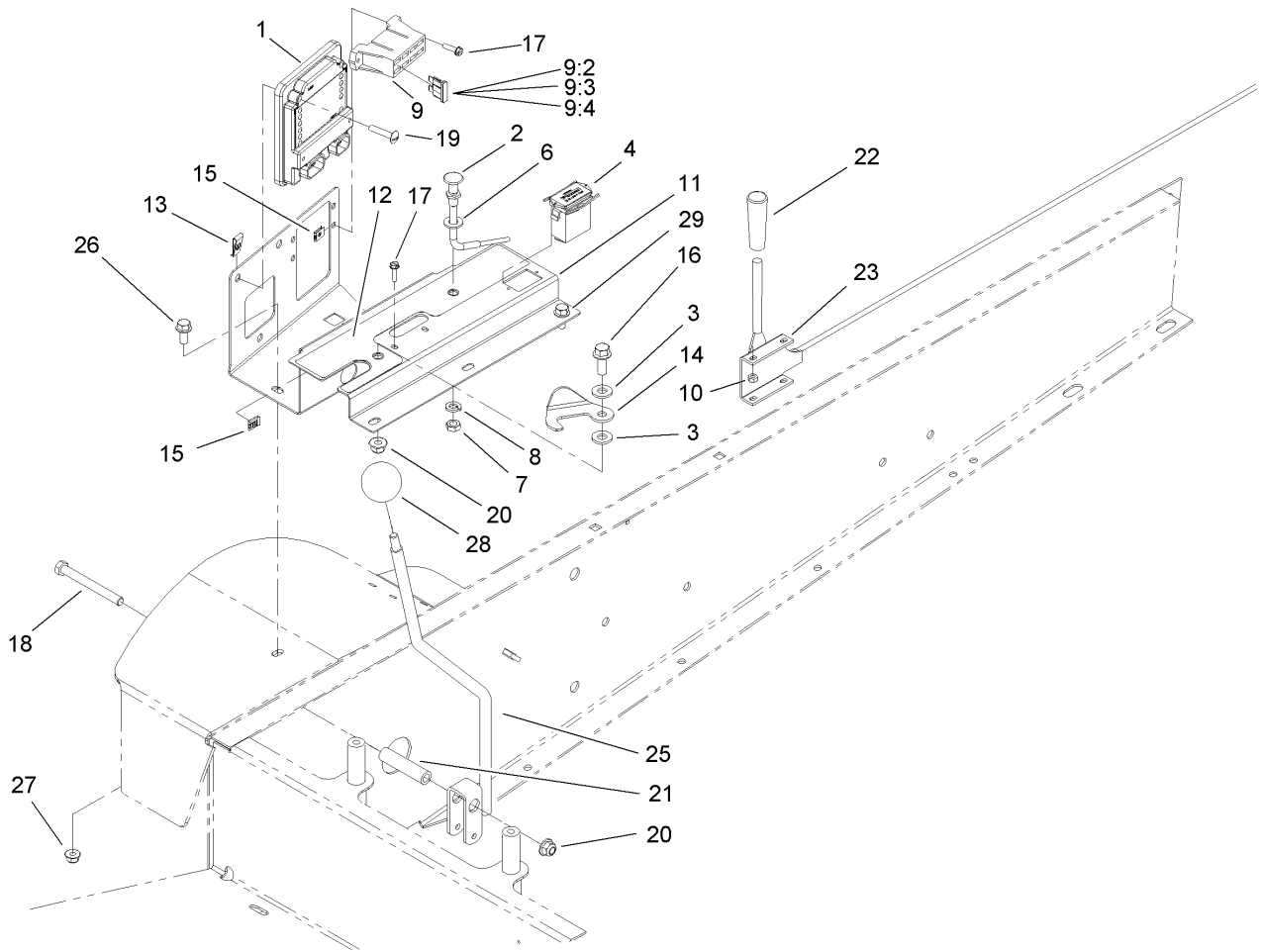

Lower Control Panel Assembly

Ref	Part No.	Qty.	Description
1	106-9277	1	Module-Control, Standard
2	110-3067	1	Choke Control ASM
3	66-2920	2	Washer-Friction
4	1-513374	1	Meter-Hour
6	3256-24	1	Washer-Flat
7	3220-3	1	Nut-HJ
8	3253-21	1	Washer-Lock
9	110-1684	1	Harness-Wire, Main
9:2	94-6710	1	Fuse-Blade, 2 Amp
9:3	218-578	1	Fuse-10 Amp
9:4	109355	1	Fuse-15 Amp
10	3296-2	2	Nut-Lock
11	108-2030-03	1	Cover-Lower
12	108-9691	1	Decal-Panel Lower
13	3290-199	3	Nut-Speed
14	108-2032	1	Latch-Lever
15	107-1013	8	Nut-Speed, U-Type
16	3234-11	1	Screw-HHF
17	32105-13	4	Screw-SHH
18	323-15	1	Screw-HH
19	3258-19	3	Screw
20	104-8301	2	Nut-Flange, NI
21	84-2350	1	Spacer-Long
22	233-39	1	Knob-Control

Ref	Part No.	Qty.	Description
23	110-5689	1	Throttle Control ASM
25	108-2035-03	1	Lift Lever ASM
26	3234-5	1	Screw-HHF
27	104-8300	1	Nut-Flange, NI
28	233-21	1	Knob
29	3234-14	3	Screw-HHF

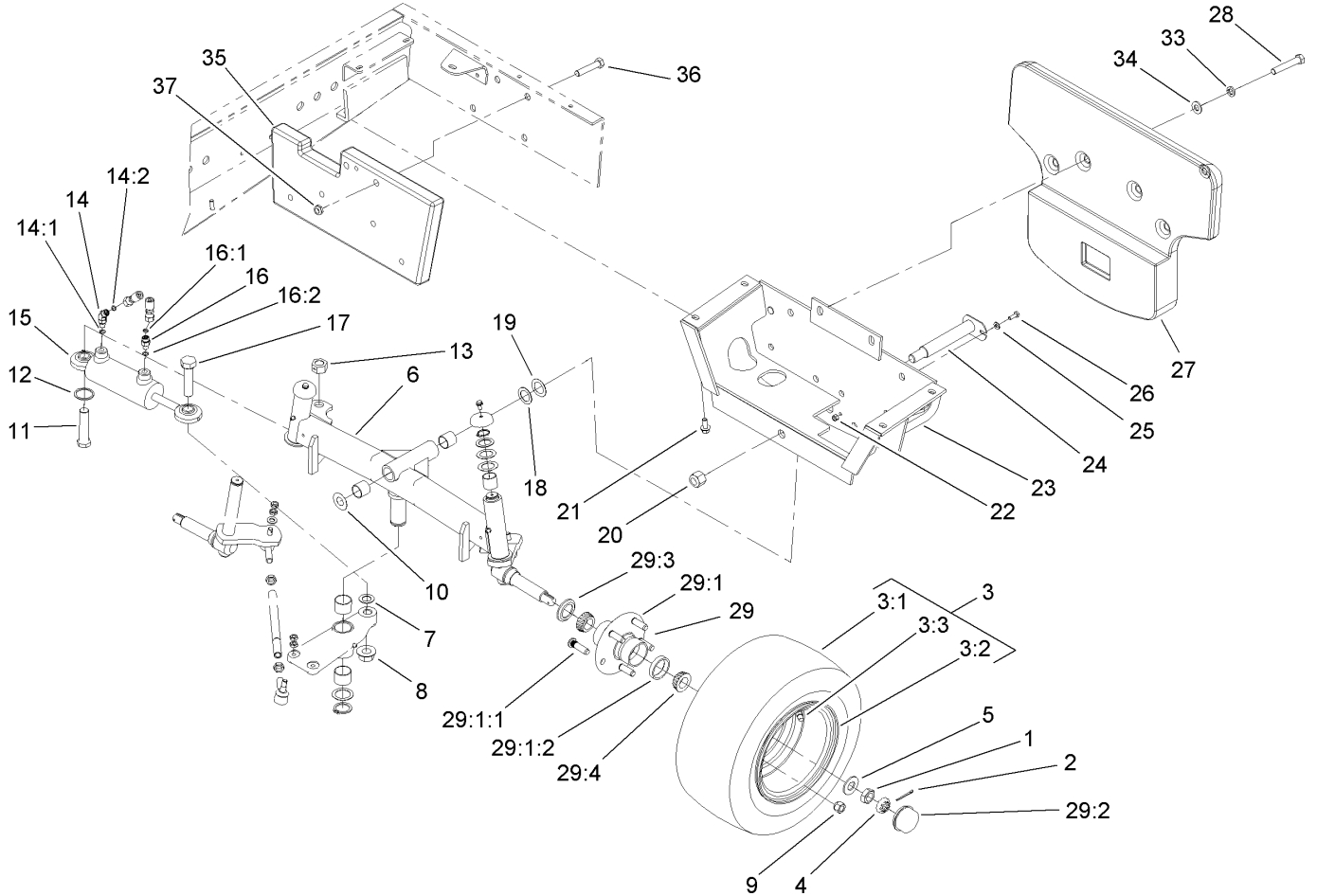

Rear Axle and Tire Assembly

Ref	Part No.	Qty.	Description
1	3220-7	2	Nut-Jam
2	3272-13	2	Pin-Cotter
2	3	2	Wheel And Tire ASM
3:1	231-105	1	Tire-Rib
3:2	107-9059	1	Wheel
3:3	232-35	1	Valve Stem And Cap ASM
4	93-0307	2	Nut-Lock, Retainer
5	93-0309	2	Washer-Tab
2	6	1	Rear Axle ASM
7	67-9410	1	Washer
8	32128-45	1	Locknut-Flange
9	242-50	10	Nut-Lug
10	71-4540	1	Washer-Thrust
11	67-7300	1	Screw-HH
12	67-7250	1	Spacer-Ring
13	32153-6	1	Nut-Lock
14	340-103	1	Fitting-HYD, 45 DEG
14:1	237-78	1	O-Ring
14:2	237-21	1	O-Ring
15	76-2070	1	Cylinder-Steering
16	340-92	1	Fitting-HYD, Straight
16:1	237-78	1	O-Ring
16:2	237-21	1	O-Ring
17	328-25	1	Screw-HH

Ref	Part No.	Qty.	Description
18	10-8110	1	Washer-Thrust
19	56-2460	2	Washer-Flat
20	3296-51	1	Nut-Lock, NI
21	3234-25	4	Screw-HHF
22	3296-42	1	Nut-Lock, NI
23	63-6430-03	1	Frame-Rear
24	63-6770-03	1	Pin-Masked
25	3256-22	1	Washer-Flat
26	321-4	1	Screw-HH
27	110-9666-01	1	Weight-Rear
28	325-14	4	Screw-HH
2	29	2	Hub ASM
29:1	21-2820	1	Hub
29:1:1	10-6830	5	Stud-Type, Drive
29:1:2	254-72	2	Bearing-Cup, Tapered
29:2	241-119	1	Cap-Dust
29:3	253-129	1	Seal
29:4	254-94	2	Bearing-Cone, Tapered
33	3253-7	4	Washer-Lock
34	3256-26	4	Washer-Flat
35	110-1995-03	1	Weight-Rear, Inside
36	325-10	2	Screw-HH
37	3296-28	2	Nut-Lock, NI

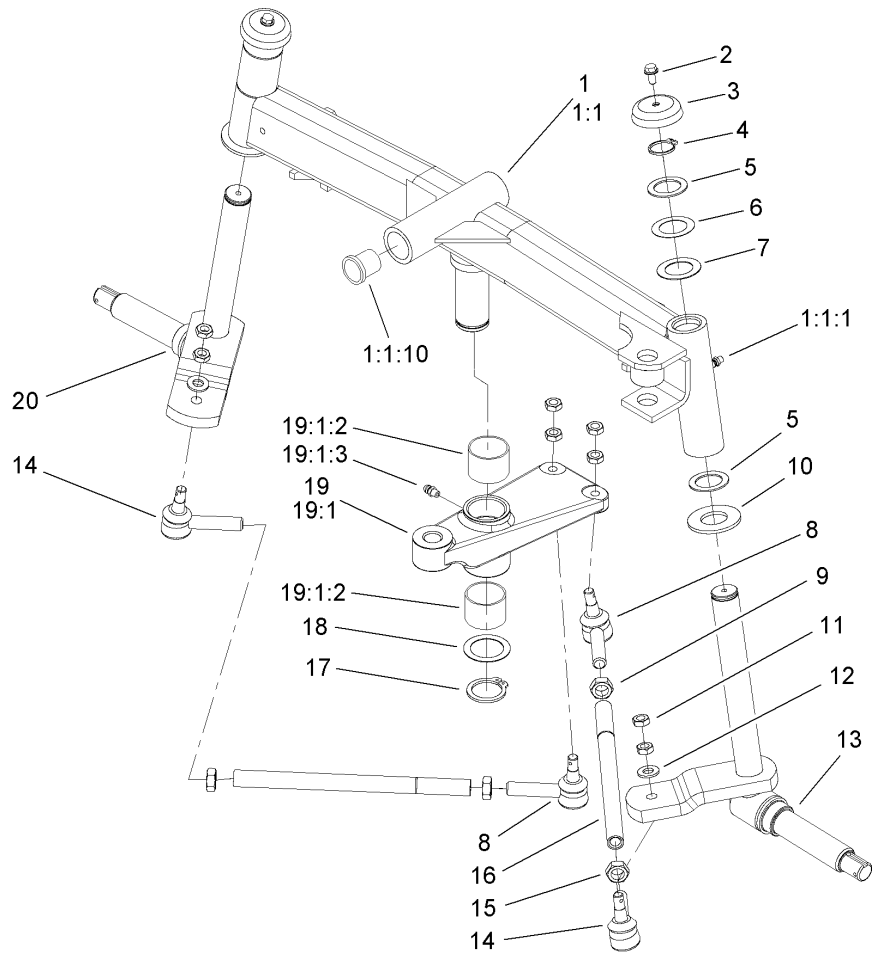

Rear Axle Assembly

Ref	Part No.	Qty.	Description
1	76-3000-03	1	Rear Axle ASM
② 1:1		1	Axle-Rear
1:1:1	302-5	3	Fitting-Grease
1:1:10	67-1750	6	Bushing
2	3234-13	2	Screw-HHF
3	66-2990-03	2	Cap-Spindle
4	32151-36	2	Ring-Retaining
5	10-8110	4	Washer-Thrust
6	56-2460	2	Washer-Flat
7	5-1226	2	Washer
8	110-9686-03	2	LH Ball Joint ASM
9	3220-12	2	Nut-HJ (LH Thread)
10	256-121	2	Washer-Thrust
11	3220-3	8	Nut-HJ
12	3256-24	2	Washer-Flat
13	107-2943-03	1	RH Spindle ASM
14	110-9685-03	2	RH Ball Joint ASM
15	3220-5	2	Nut-Jam
16	63-6880	2	Tie Rod-Steering
17	32151-77	1	Ring-Retaining, EXT
18	76-2980	1	Washer-Thrust
19	100-6598-03	1	Steering Pivot ASM
② 19:1		1	Pivot-Steering
19:1:2	76-2970	2	Bushing-Straight

Ref	Part No.	Qty.	Description
19:1:3	302-5	1	Fitting-Grease
20	107-2942-03	1	LH Spindle ASM

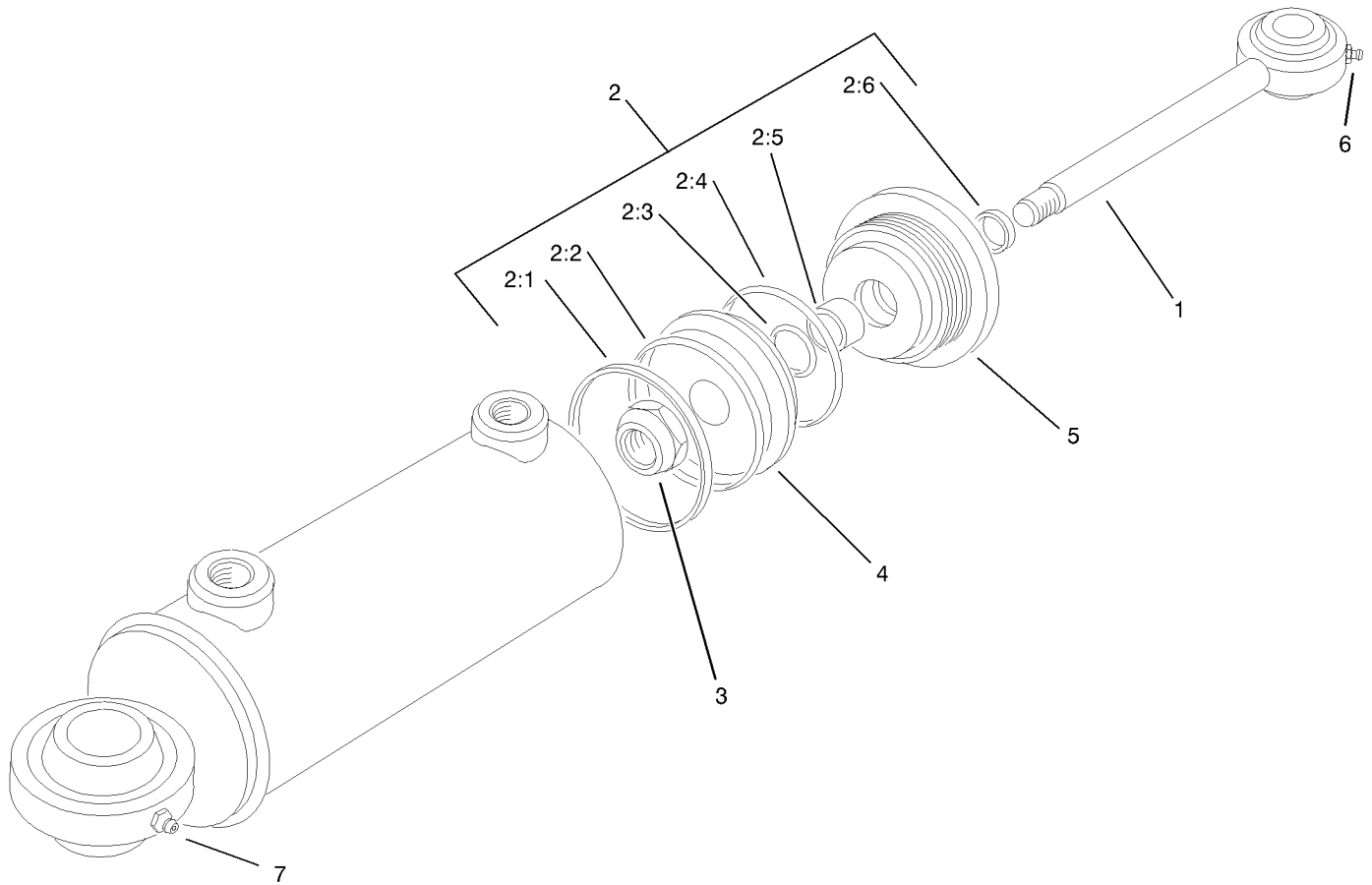

Steering Cylinder Assembly No. 76-2070

Ref	Part No.	Qty.	Description
1		1	Rod-Piston
2	76-2090	1	Seal Kit
2:1		1	Seal
2:2		1	O-Ring
2:3		1	O-Ring
2:4		1	O-Ring
2:5		1	U-Cup
2:6		1	Wiper
3		1	Nut-Lock
4		1	Piston
5		1	Gland
6	302-40	1	Fitting-Grease
7	302-5	1	Fitting-Grease

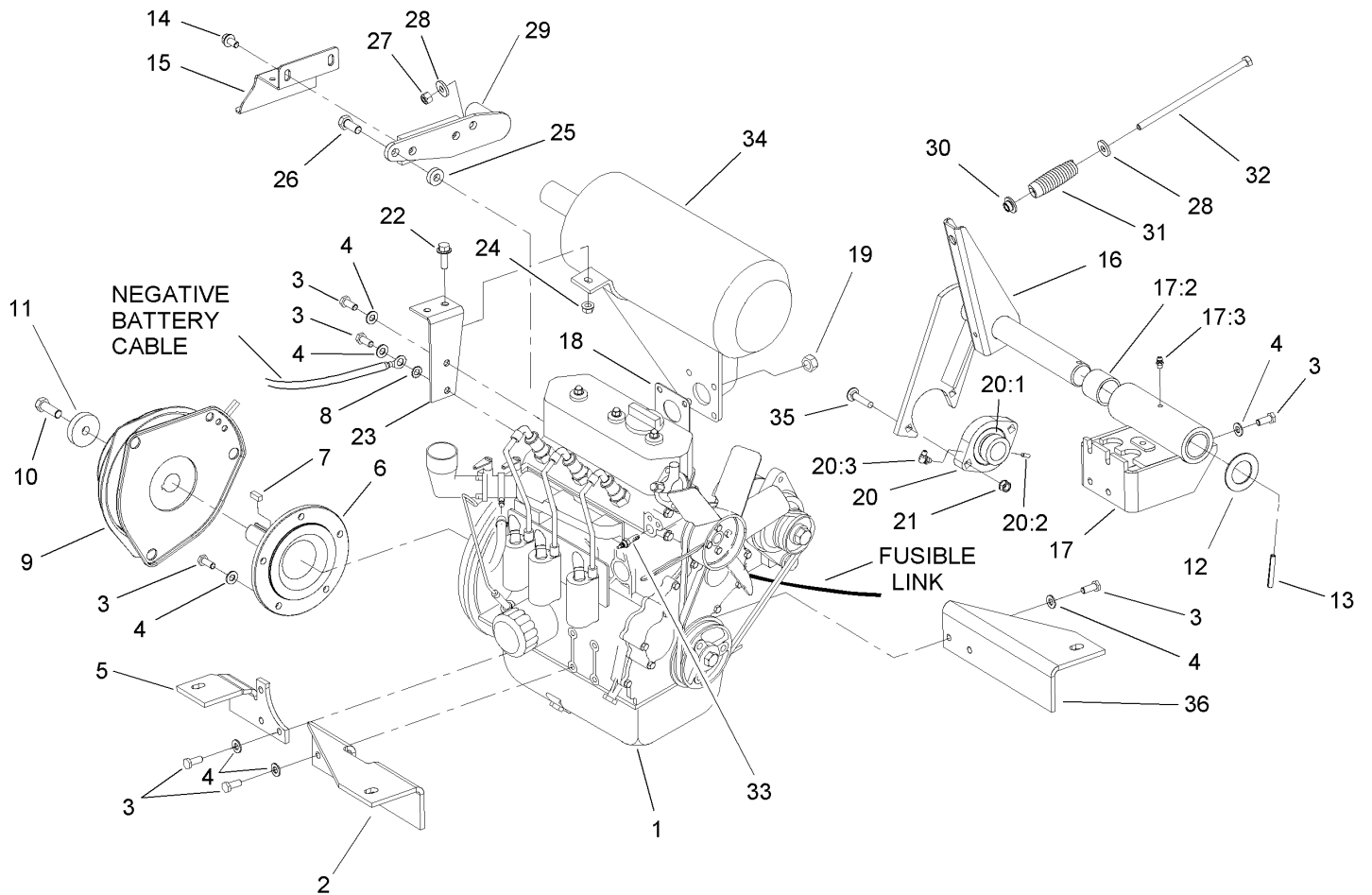

Engine, Muffler and Clutch Assembly

Ref	Part No.	Qty.	Description
1	99-8440	1	Engine-Briggs Daihatsu Dm950G
2	95-3300-03	1	Bracket-Engine, Right Front
3	33114-020	18	Screw-HH
4	3256-23	18	Washer-Flat
5	94-7416-03	1	Bracket-Mount, Engine
6	94-7430	1	Shaft-Stub
7	63-8150	1	Key-Square
8	3255-8	1	Washer-Lock
9	107-9061	1	Electric Clutch / Brake ASM
10	3212-5	1	Screw-HH
11	105-3698	1	Spacer
12	3-4324	1	Washer-Flat
13	32121-32	1	Pin-Roll
14	3234-14	2	Screw-HHF
15	108-1395-03	1	Stop-Clutch
16	106-4381-03	1	PTO Tension Shaft ASM
17	94-7344	1	Pivot Plate ASM
17:2	256-299	2	Bushing-Straight
17:3	302-5	1	Fitting-Grease
18	99-9179	1	Gasket-Exhaust
19	99-9176	4	Nut-Hex
20	92-8799	1	Bearing-Flange
20:1	251-77	1	Collar-Lock, Bearing
20:2	3245-35	1	Screw-Set

Ref	Part No.	Qty.	Description
20:3	302-40	1	Fitting-Grease
21	32149-1	2	Nut-Keps
22	3234-29	1	Screw-HHF
23	94-7433-03	1	Bracket-Muffler
24	32128-20	1	Nut-HF
25	5-0652	1	Spacer
26	43-0090	2	Screw-HH
27	3296-29	1	Nut-Lock, NI
28	4-2390	2	Washer-Flat
29	108-6579-03	1	Mount Bracket ASM
30	27-6600	1	Spacer-Coupling
31	21-0400-01	1	Spring-Compression
32	110-9696	1	Bolt-HH
33	108-9692	1	Switch-Temperature
34	108-8696	1	Muffler-Exhaust
35	3230-4	2	Screw-CARR
36	95-3097-03	1	Bracket-Engine, Left Front

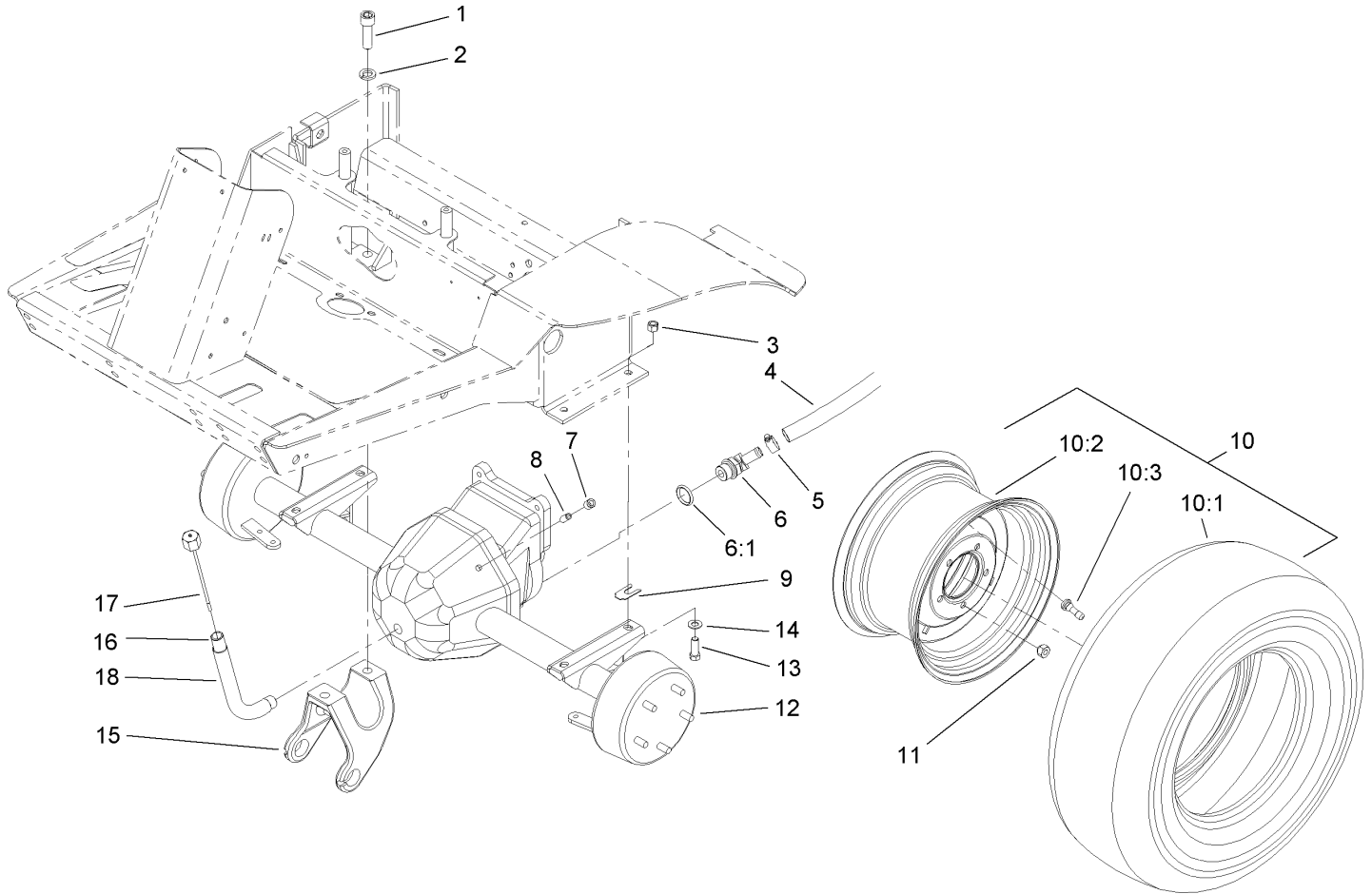

Front Axle Assembly

Ref	Part No.	Qty.	Description
1	3273-38	4	Screw-HSH
2	3253-8	4	Washer-Lock
3	3296-48	4	Nut-Lock, NI
4	92-5083	1	Hose-HYD
5	2412-119	1	Clamp-Worm
6	92-5088	1	Fitting-Elbow, 45 DEG
6:1	237-81	1	O-Ring
7	2810-1	1	Coupling-Pipe
8	289-6	1	Nipple-Pipe
9	42-6080	1	Shim-Axle
10		2	Wheel And Tire ASM
10:1	108-6594	1	Tire-Standard
10:2	108-1358	1	Wheel
10:3	232-27	1	Stem-Valve
11	242-50	10	Nut-Lug
12	108-6599-03	1	Axle ASM
13	324-5	4	Screw-HH
14	3256-25	4	Washer-Flat
15	110-9678-03	2	Bracket-Carrier
16	105-7169	1	Tube-Fill, Oil
17	105-7172	1	Dipstick ASM
18	110-5651	1	Sleeve-Protective

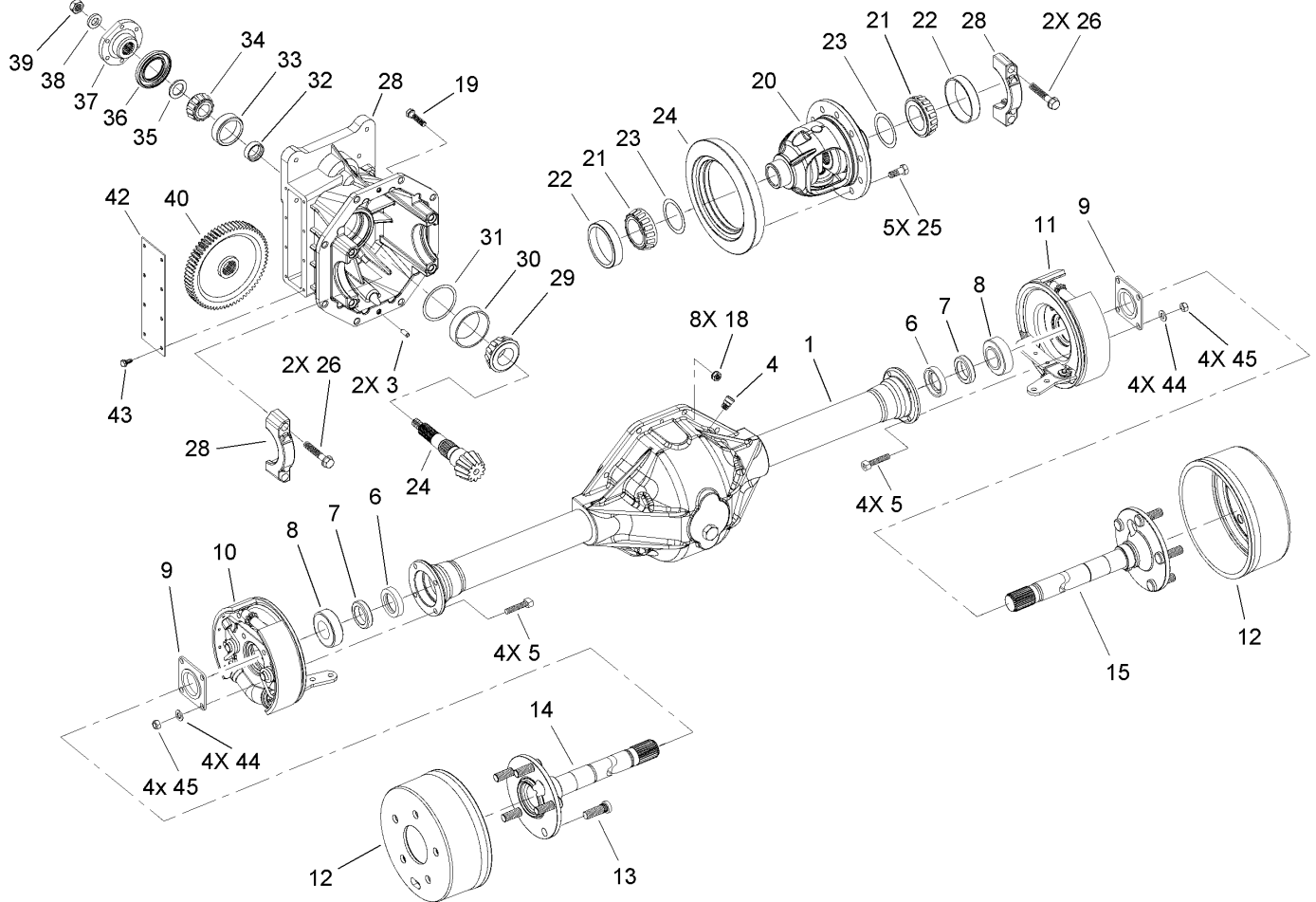

Front Axle Assembly No. 108-6599-03

Ref	Part No.	Qty.	Description
1	110-9670	1	Lower Housing ASM
3	21-8270	2	Pin-Dowel
4	72-9420	1	Vent
5	94-6934	8	Screw-HH
6	24-8840	2	Ring-Retaining, Wheel Bearing
7	92-1774	2	Seal-Oil
8	21-8180	2	Bearing ASM
9	28-0670	2	Seal-Grease
10		1	Brake ASM, RH
11		1	Brake ASM, LH
12	110-3072	2	Drum-Brake
13	106-9205	10	Stud-Wheel
14	110-3073	1	Shaft-Axle, RH
15	110-3074	1	Shaft-Axle, LH
18	32149-5	8	Nut-Keps
19	3210-8	8	Screw-HH
20	110-4136	1	Differential Case ASM
21	254-65	2	Cone-Bearing, Roller
22	254-66	2	Cup-Bearing, Roller
23	21-8090	1	Shim-Bearing, Differential (.003)
23	21-8100	1	Shim-Bearing, Differential (.005)
23	21-8110	1	Shim-Bearing, Differential (.010)
23	21-8120	1	Shim-Bearing, Differential (.030)
24	92-1676	1	Gear And Pinion ASM

Ref	Part No.	Qty.	Description
25	21-7770	5	Screw-Gear, Drive
26	92-1773	4	Screw-HHF
28	110-3076	1	Carrier ASM
29	43-6760	1	Bearing-Roller, Cone Taper
30	43-6750	1	Bearing-Taper, Cup
31	43-6710	1	Shim-Pinion (.003)
31	43-6711	1	Shim-Pinion (.005)
31	43-6712	1	Shim-Pinion (.010)
31	43-6713	1	Shim-Pinion (.030)
32	21-8020	1	Spacer-Bearing
33	254-90	1	Bearing-Cup
34	254-91	1	Cone-Bearing
35	72-3570	1	Shim-Bearing, Front (.094)
35	72-3571	1	Shim-Bearing, Front (.096)
35	72-3572	1	Shim-Bearing, Front (.098)
35	72-3573	1	Shim-Bearing, Front (.100)
35	72-3574	1	Shim-Bearing, Front (.102)
35	72-3575	1	Shim-Bearing, Front (.104)
35	72-3576	1	Shim-Bearing, Front (.106)
35	72-3577	1	Shim-Bearing, Front (.108)
35	72-3578	1	Shim-Bearing, Front (.110)
35	72-3580	1	Shim-Bearing, Front (.112)
35	72-3581	1	Shim-Bearing, Front (.114)
35	72-3582	1	Shim-Bearing, Front (.116)

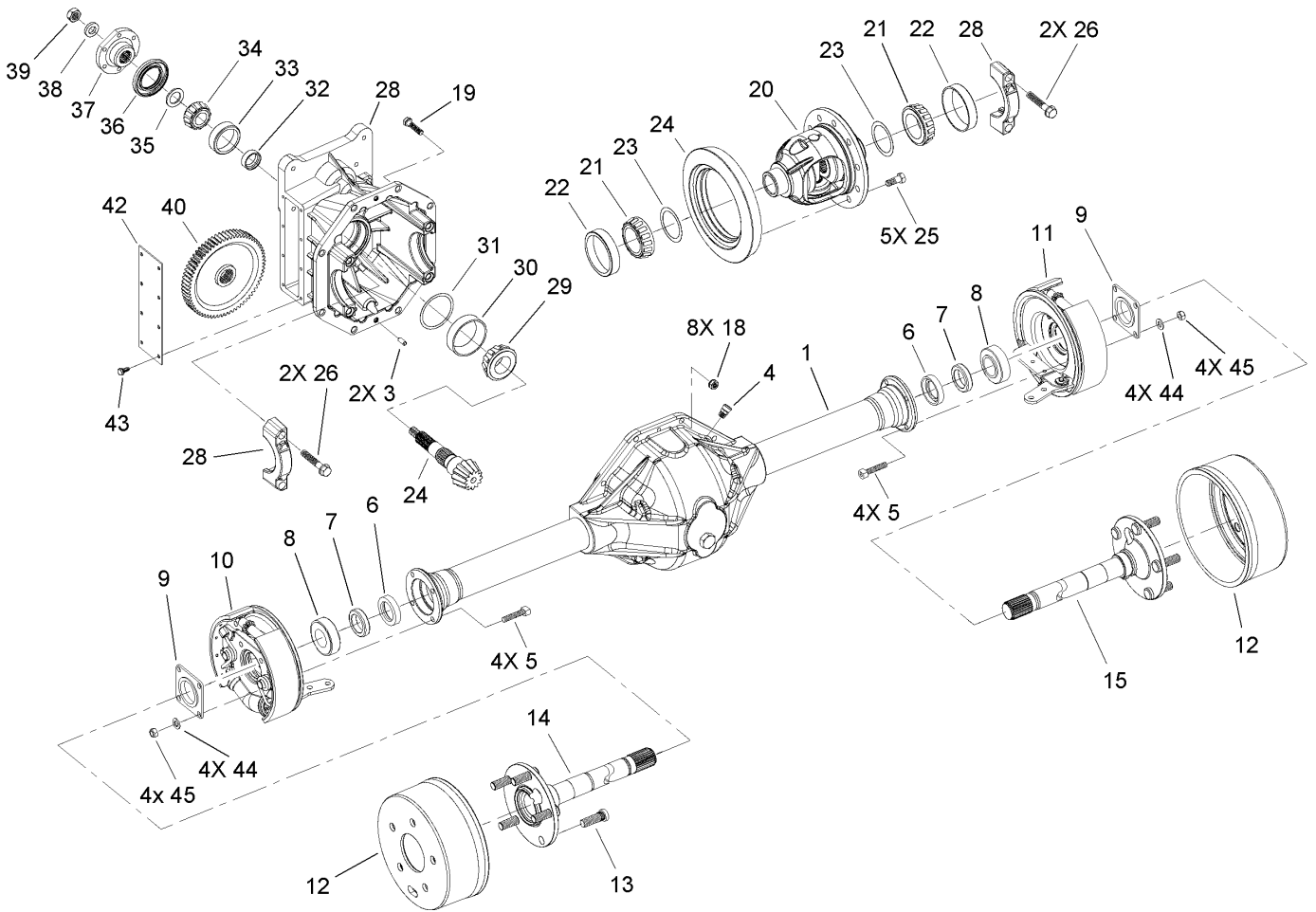

Front Axle Assembly No. 108-6599-03 (continued)

Ref	Part No.	Qty.	Description
35	72-3583	1	Shim-Bearing, Front (.118)
35	72-3584	1	Shim-Bearing, Front (.120)
35	72-3585	1	Shim-Bearing, Front (.125)
35	72-3586	1	Shim-Bearing, Front (.127)
35	72-3587	1	Shim-Bearing, Front (.129)
35	72-3588	1	Shim-Bearing, Front (.131)
35	72-3590	1	Shim-Bearing, Front (.133)
35	72-3591	1	Shim-Bearing, Front (.135)
35	72-3592	1	Shim-Bearing, Front (.137)
35	72-3593	1	Shim-Bearing, Front (.139)
35	72-3594	1	Shim-Bearing, Front (.141)
35	72-3595	1	Shim-Bearing, Front (.143)
35	72-3596	1	Shim-Bearing, Front (.145)
35	72-3597	1	Shim-Bearing, Front (.147)
35	72-3598	1	Shim-Bearing, Front (.149)
35	72-3600	1	Shim-Bearing, Front (.151)
36	71-4330	1	Seal
37	68-7010	1	Flange
38	71-4340	1	Washer
39	71-4350	1	Nut
40	86-7230	1	Gear-Input, Transmission
42	21-7830	1	Cover-Gear
43	12-5450	8	Screw
44	94-6936	8	Washer-Hardened

Ref	Part No.	Qty.	Description
45	94-6935	8	Locknut

★ REQUIRES SPECIAL TOOLS TO INSTALL. SEE REPAIR INSTRUCTION MANUAL.

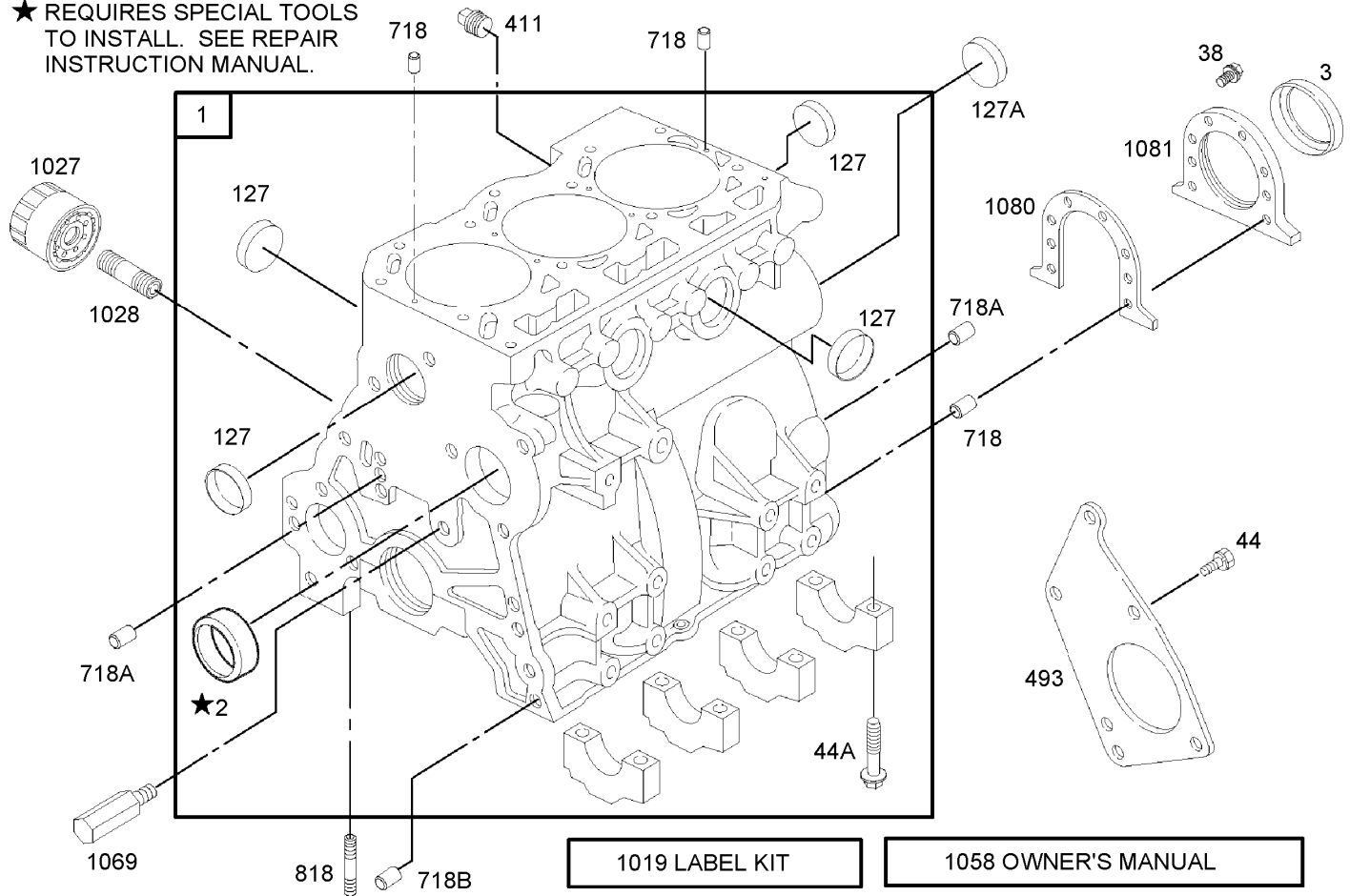

Cylinder Assembly

Ref	Part No.	Qty.	Description
1	99-9251	1	Cylinder ASM
2	99-9002	1	Bushing
3	99-9003	1	Seal-Oil
38	99-9004	6	Screw-Hex
44	99-9005	3	Screw-Hex
127	99-9008	7	Plug-Welch
411	99-9010	1	Plug-Welch
44A	99-9006	8	Screw-Hex
493	99-9011	1	Bracket-Mounting
718	99-9012	4	Pin-Locating
818	99-9007	2	Stud-Metric
1019	99-9015	1	Label Kit
1027	108-3842	1	Filter-Oil
1028	99-9018	1	Adapter-Filter, Oil
1058	99-9019	1	Manual-Owners, Engine
1069	99-9020	1	Nozzle-Oil
1080	99-9021	1	Gasket-Retainer
1081	99-9022	1	Retainer-Seal
127A	99-9009	1	Plug-Welch
718A	99-9013	3	Pin-Locating
718B	99-9014	2	Pin-Locating

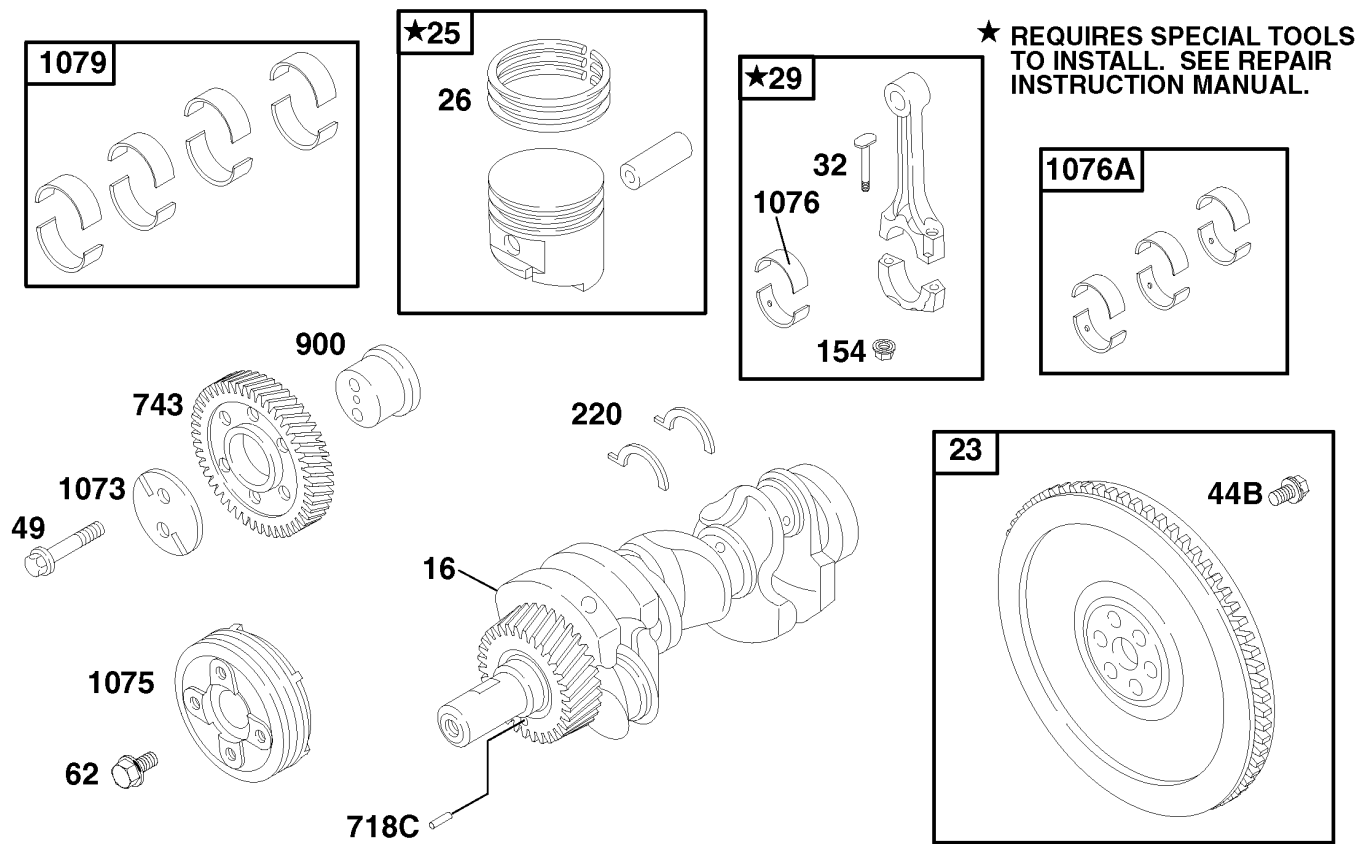

Crankshaft Assembly

Ref	Part No.	Qty.	Description
16	99-9252	1	Crankshaft
23	99-9024	1	Flywheel
25	99-9025	3	Piston ASM (Standard)
25	99-9026	3	Piston ASM (.010 Over)
26	99-9028	3	Ring Set (.010 Over)
26	99-9027	3	Ring Set (Standard)
29	99-9029	3	Rod-Connecting
32	99-9030	6	Screw-Rod, Connecting
44B	99-9031	6	Screw-Hex
49	99-9032	2	Screw-Hex
62	99-9033	1	Screw-Hex
154	99-9034	6	Nut-Hex
220	99-9035	1	Washer-Thrust
220	99-9036	1	Washer-Thrust (.005 In Oversized)
718C	99-9037	1	Pin-Locating
743	99-9609	1	Gear-Drive
900	99-9039	1	Shaft-Gear
1073	99-9040	1	Plate-Gear, Idler
1075	99-9041	1	Pulley-Crankshaft
1076	99-9042	3	Bearing-Rod
1076A	99-9043	3	Set-Bearing, Rod
1076A	99-9044	3	Set-Bearing, Rod (.010 Undersized)

Ref	Part No.	Qty.	Description
1079	99-9045	4	Set-Bearing, Main (Set Of 8)
1079	99-9046	4	Set-Bearing, Main (.010 Undersized)

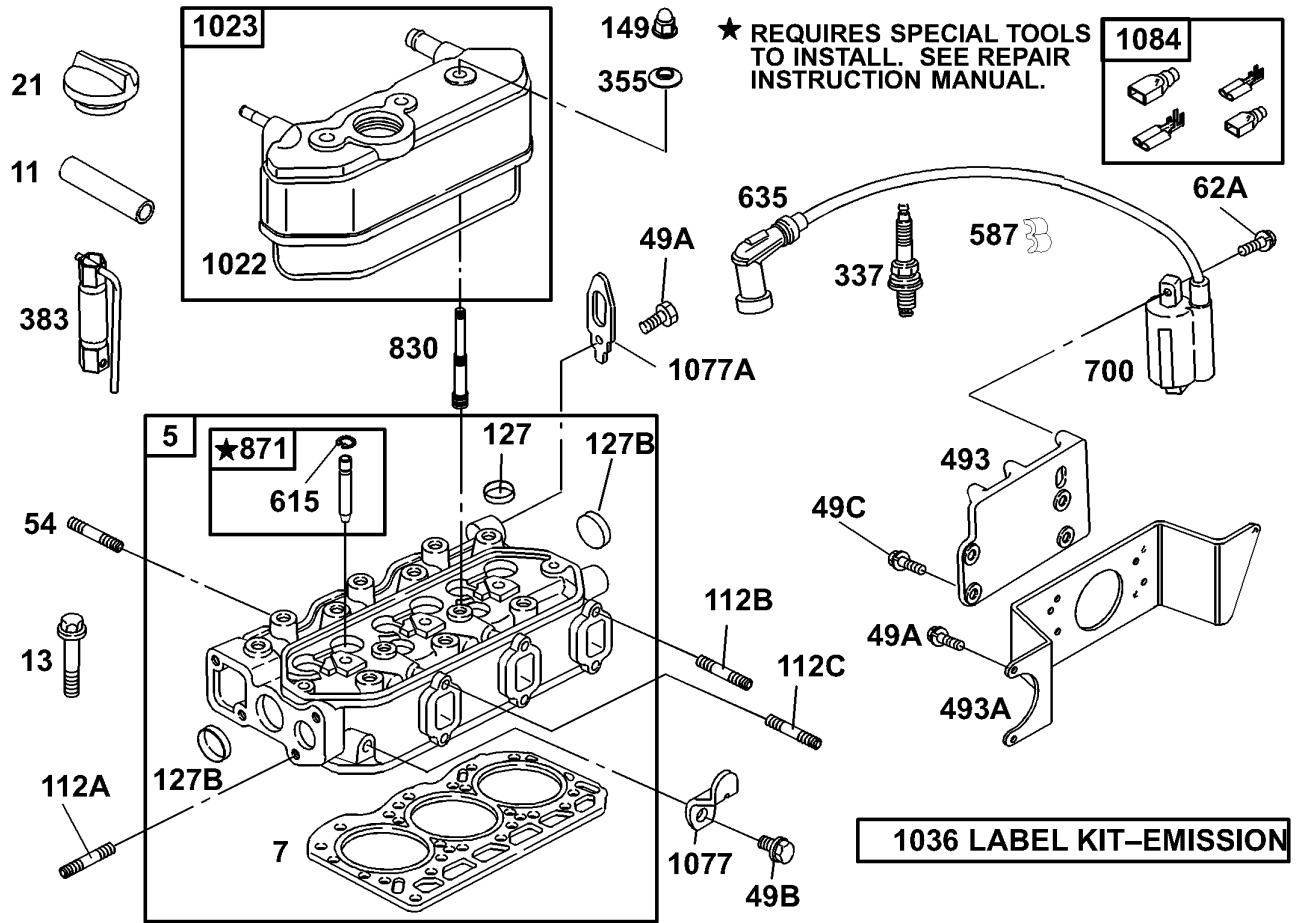

Cylinder Head Assembly

Ref	Part No.	Qty.	Description
1022	99-9073	1	Gasket-Cover, Rocker
1023	99-9074	1	Cover-Rocker
1036	99-9075	1	Emission Label Kit
1077	99-9076	1	Bracket-Lifting
1077A	99-9077	1	Bracket-Lifting
1084	99-9078	1	Connector
11	99-9049	1	Tube-Breather
112A	99-9057	2	Stud-Metric
112B	99-9058	5	Stud-Metric
112C	99-9059	1	Stud-Metric
127	99-9008	2	Plug-Welch
127B	99-9060	2	Plug-Welch
13	99-9255	14	Screw-Hex
149	99-9061	3	Nut-Hex, Metric
21	99-9052	1	Cap-Fill, Oil
337	77-7330	3	Plug-Spark
355	99-9063	3	Washer-Seal
383	99-9064	1	Wrench-Plug, Spark
493	99-9065	1	Bracket-Mounting
493A	99-9220	1	Bracket-Support
49A	99-9256	3	Screw-Hex
49B	99-9054	2	Screw-Hex
49C	99-9202	4	Screw-Hex
5	99-9253	1	Head-Cylinder

Ref	Part No.	Qty.	Description
54	99-9055	2	Stud-Metric
587	99-9066	2	Clip-Wire
615	99-9067	6	Retainer
62A	99-9056	6	Screw-Hex
635	99-9068	3	Boot-Plug, Spark
7	99-9254	1	Gasket-Head, Cylinder
700	99-9069	3	Coil-Ignition
830	99-9101	3	Stud-Arm, Rocker
871	99-9070	6	Bushing-Guide

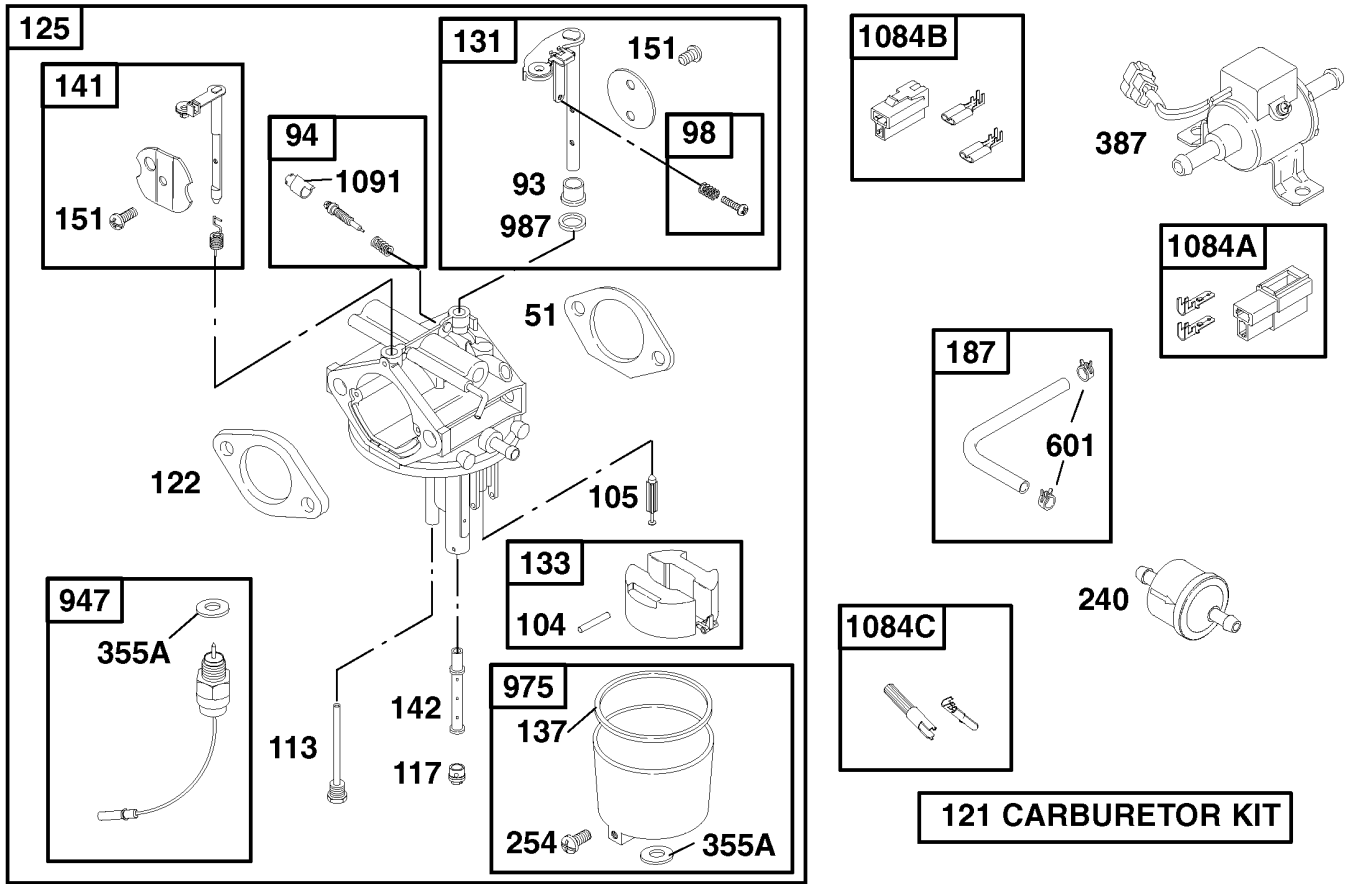

Carburetor Assembly

Ref	Part No.	Qty.	Description
51	99-9182	1	Gasket-Intake
93	99-9224	1	Bushing
94	99-9224	1	Valve-Idle Adj.
98	99-9225	1	Screw-Idle Speed
104	99-9226	1	Pin-Float Hinge
105	99-9227	1	Valve-Needle
113	99-9228	1	Tube-Jet
117	99-9229	1	Jet-Main
117	99-9230	1	Jet-Main (High Altitude)
121	99-9231	1	Carbuertor Kit
122	99-9184	1	Spacer-Carburator
125	99-9185	1	Carburetor
131	99-9232	1	Shaft-Throttle
133	99-9233	1	Float-Carburetor
137	99-9234	1	Gasket-Bowl, Float
141	99-9235	1	Shaft-Choke
142	99-9236	1	Nozzle-Carburetor
151	99-9237	1	Screw-Cross / Slotted
187	99-9238	1	Line-Fuel
240	95-2926	1	Fuel Filter ASM
254	99-9239	1	Drain-Carburetor. Bowl
387	99-9196	1	Pump-Fuel
601	99-9242	1	Clamp-Hose
947	99-9243	1	Solenoid-Fuel

Ref	Part No.	Qty.	Description
975	99-9244	1	Bowl-Float
987	99-9246	1	Collar
1091	99-9246	1	Cap-Limiter
355A	99-9240	1	Washer-Seal
1084A	99-9199	1	Connector
1084B	99-9213	1	Connector
1084C	99-9245	1	Connector

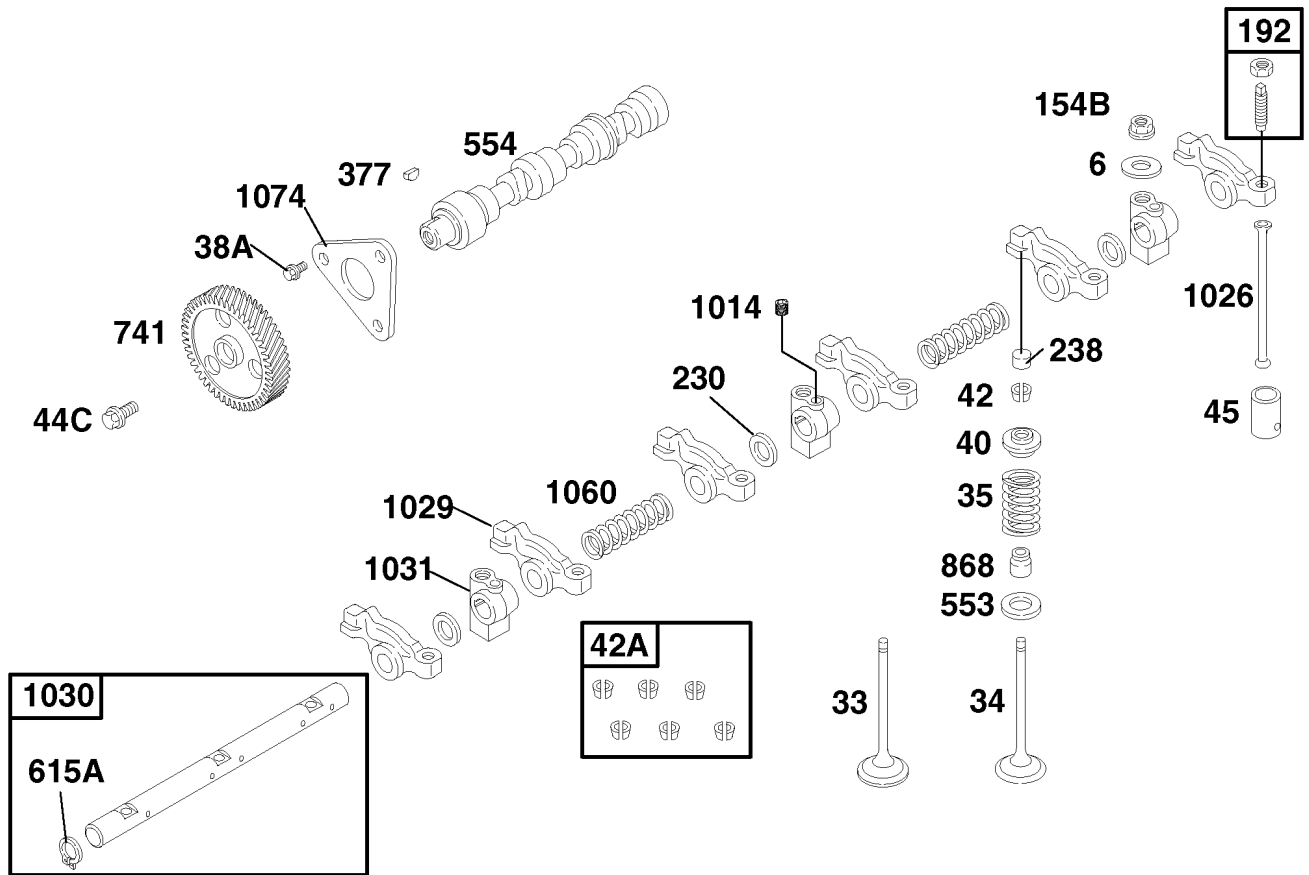

Rocker Arm Assembly

Ref	Part No.	Qty.	Description
6	99-9079	3	Washer-Flat
33	99-9080	3	Valve-Exhaust
34	99-9081	3	Valve-Intake
35	99-9082	6	Spring-Valve
38A	99-9083	3	Screw-Hex
40	99-9084	6	Retainer-Valve
42	99-9086	1	Keeper-Valve (Set)
42A	99-9087	6	Keeper-Valve (Set Of 6)
44C	99-9085	1	Screw-Metric
45	99-9088	6	Tappet-Valve
154B	99-9091	3	Nut-Hex, Metric
192	99-9092	6	Adjuster-Arm, Rocker
230	99-9093	3	Washer-Spacer
238	99-9094	6	Cap-Valve
377	99-9095	1	Key-Woodruff
553	99-9096	6	Seat-Spring, Valve
554	99-9097	1	Shaft-Cam
615A	99-9099	2	Retainer
741	99-9641	1	Gear-Cam
868	99-9102	6	Seal-Valve
1014	99-9090	3	Screw-Metric
1026	99-9103	6	Rod-Push
1029	99-9104	6	Arm-Rocker
1030	99-9106	1	Shaft-Arm, Rocker

Ref	Part No.	Qty.	Description
1031	99-9107	3	Support-Arm, Rocker
1060	99-9108	2	Spring-Shaft, Rocker
1074	99-9109	1	Retainer-Camshaft

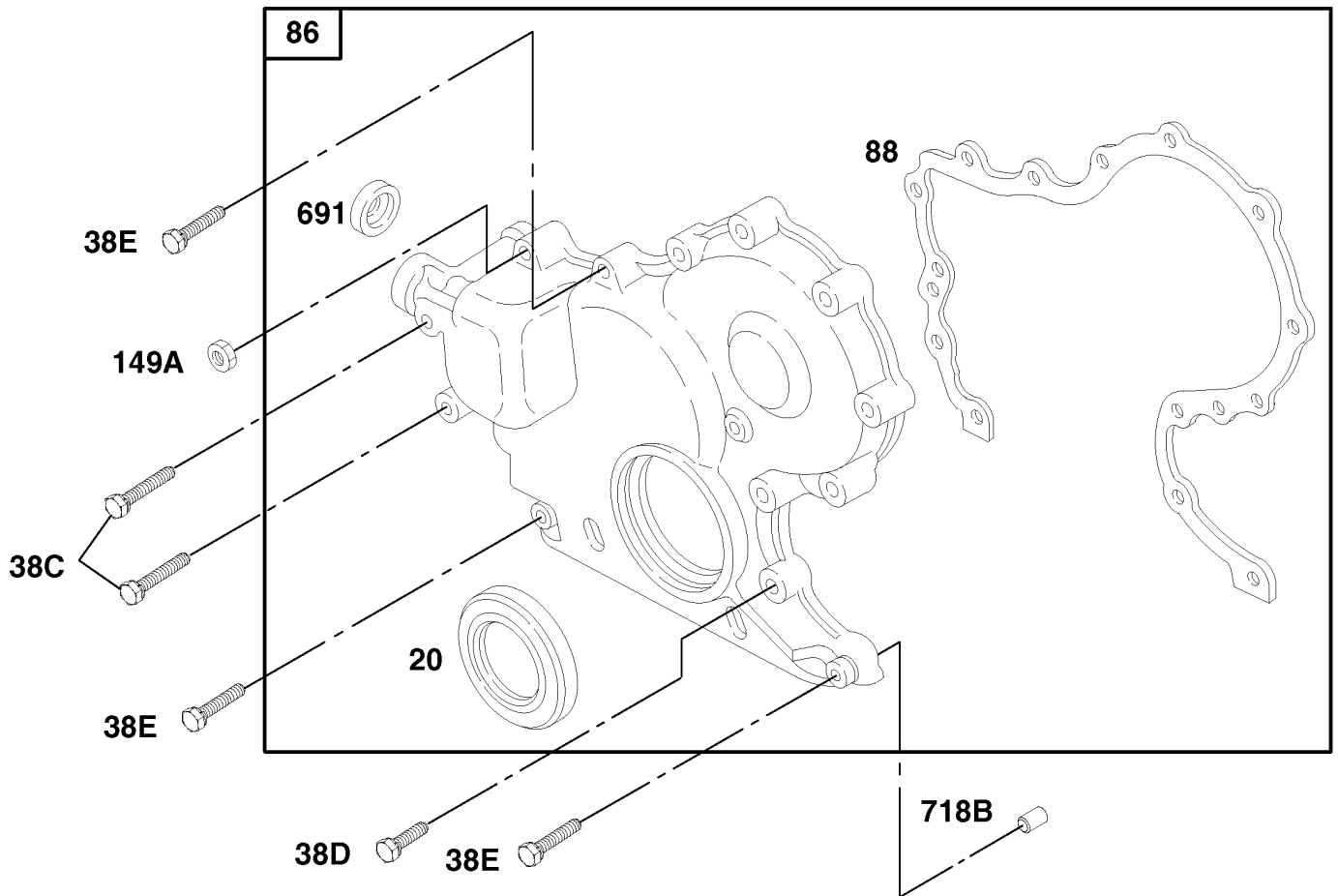

Cover Assembly

Ref	Part No.	Qty.	Description
20	99-9126	1	Seal-Oil
38C	99-9127	2	Screw-Hex
38D	99-9128	6	Screw-Hex
38E	99-9129	3	Screw-Hex
86	99-9130	1	Gear Cover ASM
88	99-9132	1	Gasket-Cover
149A	99-9114	2	Nut-Hex, Metric
691	99-9131	1	Seal-Shaft, Governor
718B	99-9014	2	Pin-Locating

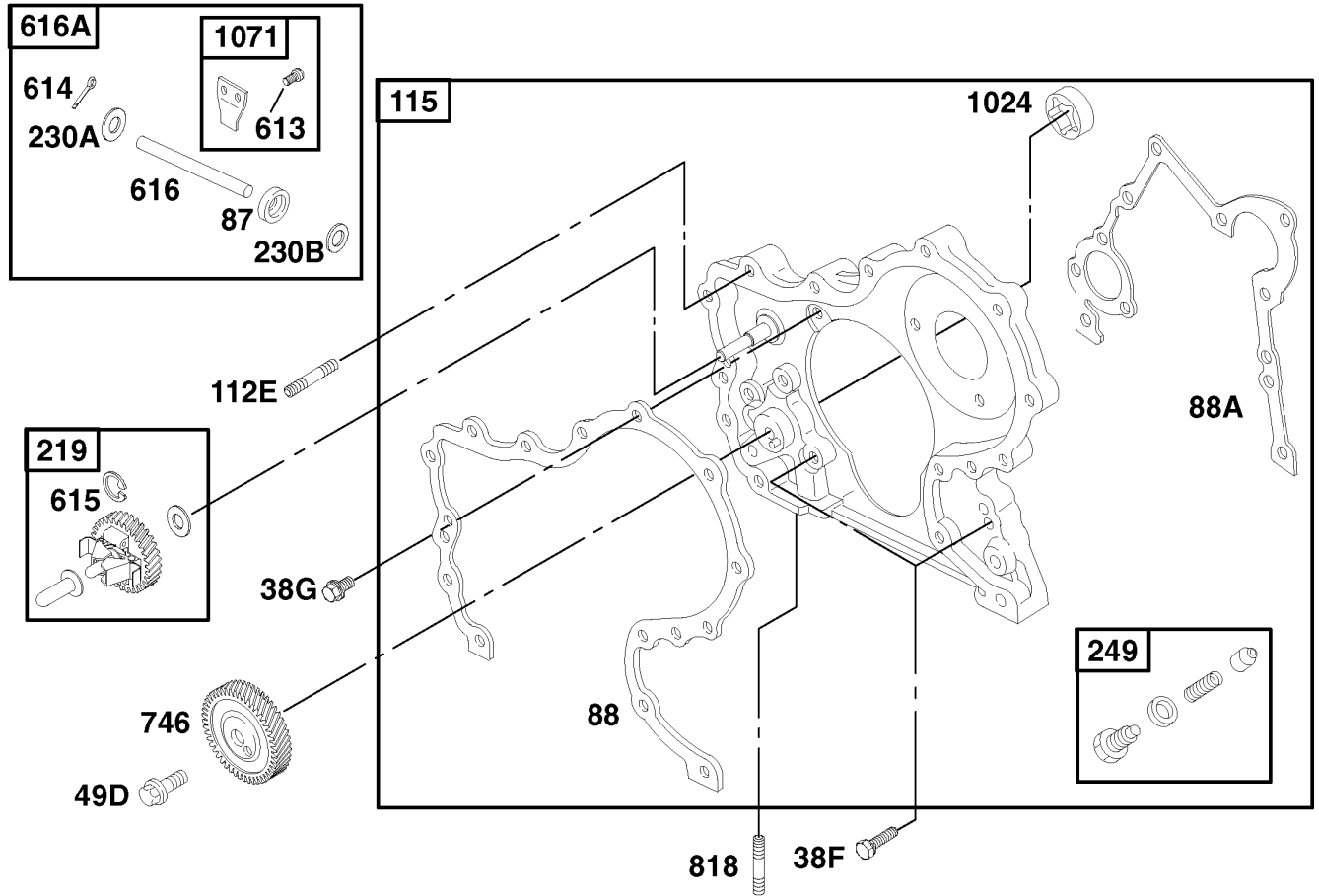

Gears and Housing

Ref	Part No.	Qty.	Description
38F	99-9133	4	Screw-Hex
38G	99-9134	1	Screw-Hex
49D	99-9135	1	Screw-Hex
87	99-9131	1	Seal-Shaft, Governor
88	99-9132	1	Gasket-Cover
88A	99-9136	1	Gasket-Cover, Gear
112E	99-9137	2	Stud-Metric
115	99-9138	1	Housing-Gear
219	99-9261	1	Gear-Governor
230A	99-9140	1	Washer-Spacer
230B	99-9141	1	Washer-Spacer
249	99-9142	1	Valve-Relief, Oil
613	99-9143	2	Screw-Hex, Torx
614	99-9053	1	Pin-Cotter
615	99-9145	1	Retainer
616	99-9146	1	Crank-Governor
616A	99-9147	1	Crank-Governor
746	99-9656	1	Gear-Drive
818	99-9007	2	Stud-Metric
1071	99-9149	1	Paddle-Governor

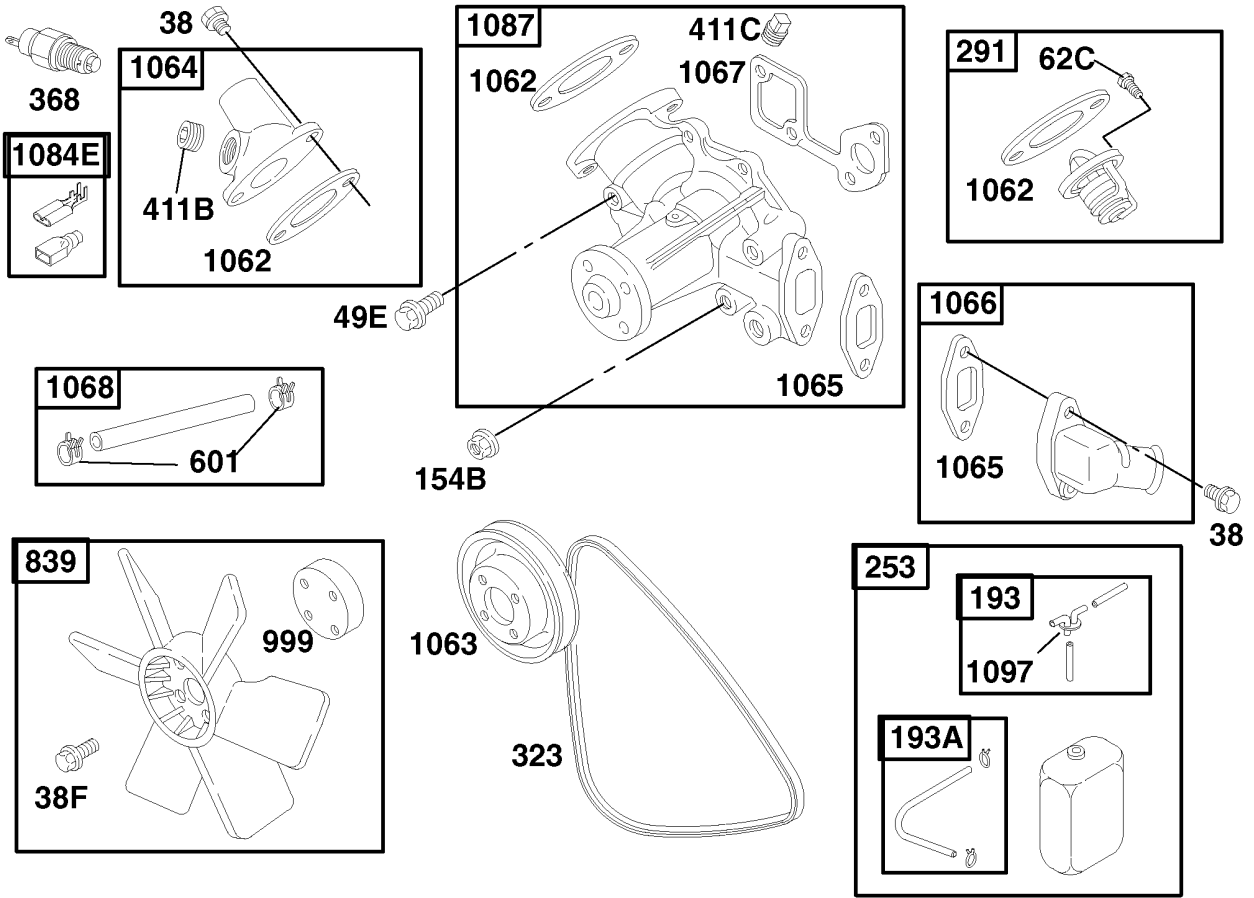

Water Pump and Fan Assembly

Ref	Part No.	Qty.	Description
38	99-9004	4	Screw-Hex
193	99-9071	1	Hose-Tank, Reserve
253	99-9154	1	Tank-Reserve
291	99-9155	1	Thermostat
323	99-9156	1	Belt-V
368	99-9157	1	Switch-Temperature, Water
38F	99-9133	4	Screw-Hex
49E	99-9151	2	Screw-Hex
601	99-9160	2	Clamp-Hose
62C	99-9152	1	Screw-Metric
839	99-9162	1	Fan-Radiator
999	99-9161	1	Spacer
1062	99-9163	1	Gasket-Outlet
1063	99-9164	1	Pulley-Pump
1064	99-9165	1	Housing-Outlet
1065	99-9166	1	Gasket-Housing, Inlet
1066	99-9167	1	Housing-Inlet
1067	99-9168	1	Gasket-Pump, Water
1068	99-9169	1	Hose Clamp ASM
1087	99-9170	1	Pump-Water
1097	93-2048	1	Cap-Tank, Overflow
154B	99-9153	1	Nut-Hex, Metric
193A	99-9072	1	Hose-Tank, Reserve
411B	99-9158	1	Plug

Ref	Part No.	Qty.	Description
411C	99-9159	1	Plug
1084E	99-9098	1	Connector

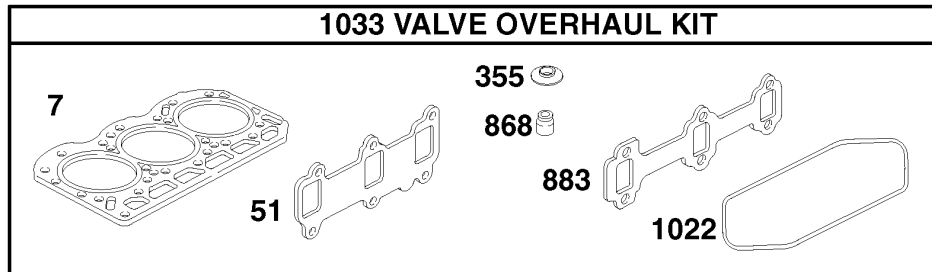
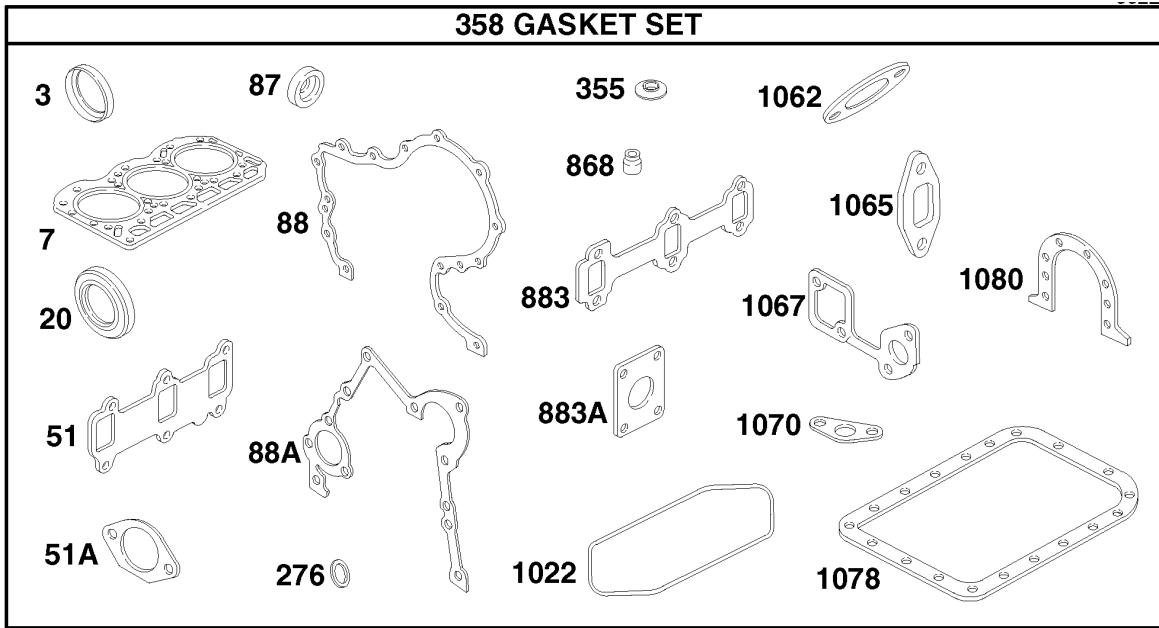

Gasket Set and Valve Overhaul Kit

Ref	Part No.	Qty.	Description
3	99-9003	1	Seal-Oil
7	99-9254	1	Gasket-Head, Cylinder
20	99-9126	1	Seal-Oil
51	99-9173	1	Gasket-Intake
51A	99-9182	1	Gasket-Intake
87	99-9131	1	Seal-Shaft, Governor
88	99-9132	1	Gasket-Cover
88A	99-9136	1	Gasket-Cover, Gear
276	99-9117	2	Washer-Seal (12Mm)
276	99-9249	2	Washer-Seal
355	99-9063	1	Washer-Seal
358	99-9263	1	Gasket Set
868	99-9102	1	Seal-Valve
883	99-9178	1	Gasket-Exhaust
883A	99-9179	1	Gasket-Exhaust
1022	99-9073	1	Gasket-Cover, Rocker
1033	99-9264	1	Valve Overhaul Kit
1062	99-9163	1	Gasket-Outlet
1065	99-9166	1	Gasket-Housing, Inlet
1067	99-9168	1	Gasket-Pump, Water
1070	99-9120	1	Gasket-Strainer, Oil
1078	99-9121	1	Gasket-Pan, Oil
1080	99-9021	1	Gasket-Retainer

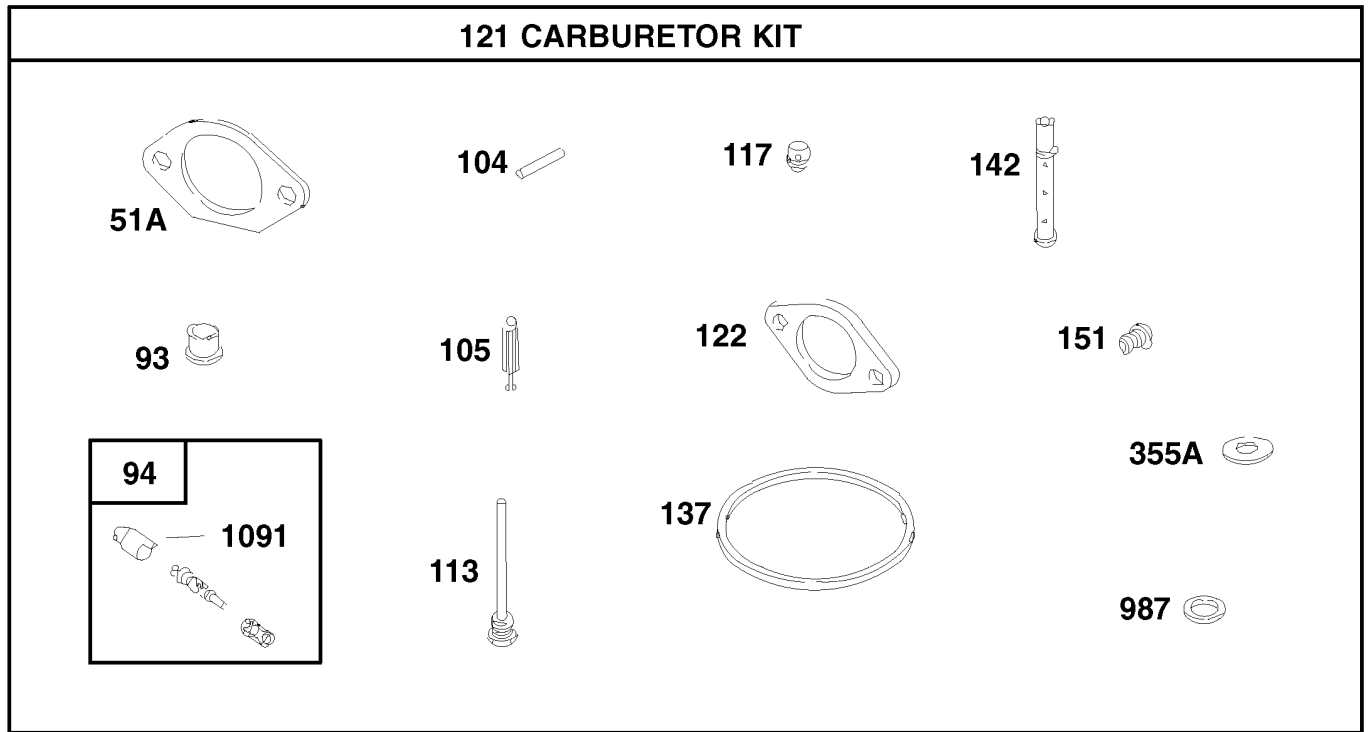

Carburetor Kit

Ref	Part No.	Qty.	Description
51A	99-9182	1	Gasket-Intake
94	99-9224	1	Valve-Idle Adj.
104	99-9226	1	Pin-Float Hinge
105	99-9227	1	Valve-Needle
113	99-9228	1	Tube-Jet
117	99-9229	1	Jet-Main
121	99-9231	1	Carbuertor Kit
122	99-9184	1	Spacer-Carburator
137	99-9234	1	Gasket-Bowl, Float
142	99-9236	1	Nozzle-Carburetor
151	99-9237	1	Screw-Cross / Slotted
355A	99-9240	1	Washer-Seal
1091	99-9246	1	Cap-Limiter

Attachments and Accessories

For 30343 - Groundsmaster 3320

Product Name	Model/Part
Premium Engine Oil, 10w30 (Drum)	108-1179
Premium Engine Oil, 10w30 (Pail)	108-1180
Premium Transmission/Hydraulic Tractor Fluid (Drum)	108-1183
Premium Transmission/Hydraulic Tractor Fluid (Pail)	108-1184
Premium All Purpose Grease	108-1190
Wheel	108-6563
Wheel And Tire ASM (Wide Tire Option)	108-6598
Armrest Adapter Kit	108-9687
Wheel Weight Kit	11-0440
Auxiliary Valve Kit	110-5670
Implement Flow Control Kit	110-5699
Tire	231-95
Rear Weight Kit	24-5780
V-Plow Mounting Kit	30311
Mechanical Seat Suspension Kit	30312
Pneumatic Seat Suspension Kit	30313
15 Cubic Foot Bagger Kit	30356
60 Inch Blower Kit	30357
Hardtop Sunshade	30359
60 Inch Side Discharge Mower	30366
62 Inch Rear Discharge Mower	30367
72 Inch Side Discharge Mower	30368
72 Inch Rear Discharge Mower	30369
62 Inch Guardian Recycler Mower	30376
72 Inch Guardian Recycler Mower	30379
Auxiliary Power Unit	30382
Cab ASM	30391
Standard Seat Kit	30398
52 Inch Blower Kit	30502
52 Inch Side Discharge Mower	30555
Arm Rest Kit	30707
48 Inch V-Plow	30750
Debris Blower	30823
Tire	69-9880
Spark Arrestor Screen	75-6880
Tire Chains (23 x 9.50-12)	82531

